

# 204<sub>SP</sub>



## PARTS MANUAL FOR HAGIE 204SP HAGIE MANUFACTURING COMPANY

721 CENTRAL AVENUE WEST  
BOX 273  
CLARION, IOWA 50525-0273

COVERS MACHINE SERIAL NUMBERS: 204SP 19001-19500

12-18 493825

To obtain the most current parts manual for your machine,  
please visit [www.hagie.com](http://www.hagie.com).

© 2018 Hagie Manufacturing Company. Clarion, Iowa USA



## DETASSELER IDENTIFICATION

Each Hagie detasseler is identified by means of a frame serial number. This serial number denotes the model, the year in which it was built, and the number of the detasseler. As for further identification, the engine has a serial number. To ensure prompt, efficient service when ordering parts or requesting service repairs from your local John Deere dealer, record the serial and identification numbers in the spaces provided below.

**NOTE:** Reference to left hand and right hand used throughout this manual refers to the position when seated in the operator's seat facing forward.

*This manual is not intended to be a complete guide for machine maintenance and repairs. If you are not properly trained to perform service on this machine, contact your local John Deere dealer for assistance. Improper maintenance or repair may result in property damage, personal injury, or death.*

DETASSELER SERIAL NUMBER

\_\_\_\_\_

ENGINE SERIAL NUMBER

\_\_\_\_\_

### FILTER QUICK REFERENCE

<u>QTY</u>	<u>P/N</u>	<u>DESCRIPTION</u>
1	605609	HYD OIL FILTER, CHARGE PUMP
1	613764	HYD TANK OIL FILTER
1	657413	CAB RECIRCULATION FILTER
1	657424	CAB PAPER FILTER
1	657425	CAB CHARCOAL FILTER
<u>T3 ENGINE</u>		
1	311530	ENGINE AIR FILTER, PRIMARY
1	311531	ENGINE AIR FILTER, SECONDARY
1	316372	ENGINE OIL FILTER
1	316684	FUEL/WATER SEPERATOR T3
1	316683	FUEL FILTER, PRIMARY ENG T3

### TRANSLATED DECAL KITS

<u>QTY</u>	<u>P/N</u>	<u>DESCRIPTION</u>
1	KDC504UKR	DECAL KIT, 204SP UKRANIAN
1	KDC505TUK	DECAL KIT, 204SP TURKISH
1	KDC506BRZ	DECAL KIT, 204SP PORTUGUESE
1	KDC507SRB	DECAL KIT, 204SP SERVIAN
1	KDC508HUN	DECAL KIT, 204SP HUNGARIAN
1	KDC509RMA	DECAL KIT, 204SP ROMANIAN
1	KDC510EGY	DECAL KIT, 204SP ARABIC
1	KDC514MEX	DECAL KIT, 204SP SPANISH
1	KDC515FRN	DECAL KIT, 204SP FRENCH
1	KDC516CHN	DECAL KIT, 204SP CHINESS

TABLE OF CONTENTS

ENGINE ASSEMBLY T3 . . . . .	4-6
RADIATOR ASSEMBLY T3. . . . .	7
A/C AND HEATER LINES. . . . .	8
BATTERY AND CABLES . . . . .	9
HYDRAULIC HOISING . . . . .	10-13
OIL COOLER ASSEMBLY . . . . .	14
HYDROSTATIC PUMP ASSEMBLY . . . . .	15
LOOP FLUSHING VALVE AND FILTER . . . . .	16-17
HYDRAULIC TANK ASSEMBLY. . . . .	18
POSITRACTION VALVE. . . . .	19-20
DUMP VALVE ASSEMBLY . . . . .	21
FLOW DIVIDER ASSEMBLY . . . . .	22
BRAKE AND SHIFT VALVE ASSEMBLY. . . . .	23
MOTOR CONTROL VALVE ASSEMBLY. . . . .	24-25
LIFT VALVE ASSEMBLY. . . . .	26-27
RETURN MANIFOLD ASSEMBLY. . . . .	28
OUTRIGGER FOLD VALVE ASSEMBLY. . . . .	29-32
STEERING CYLINDER ASSEMBLY. . . . .	33-34
LEG ASSEMBLY . . . . .	35-38
TIRE ASSEMBLY . . . . .	39
FUEL TANK ASSEMBLY. . . . .	40-41
LADDER AND SERVICE PLATFORM . . . . .	42-43
OPERATOR STATION AND CAB ASSEMBLY. . . . .	44-59
SHEET METAL ASSEMBLY. . . . .	60-63
REAR WEIGHTS. . . . .	64
OUTRIGGER AND LIFT ASSEMBLY. . . . .	65-74
LS SENSOR ASSEMBLY. . . . .	75
QUAD PULLER HEAD ASSEMBLY . . . . .	76
CUTTER HEAD ASSEMBLY. . . . .	77-79
MALE ROW CHOPPER ASSEMBLY . . . . .	80-81
TOOLBAR HEADLIGHT ASSEMBLY. . . . .	82
HYDRAULIC DIAGRAMS. . . . .	84-107
INDEX . . . . .	109

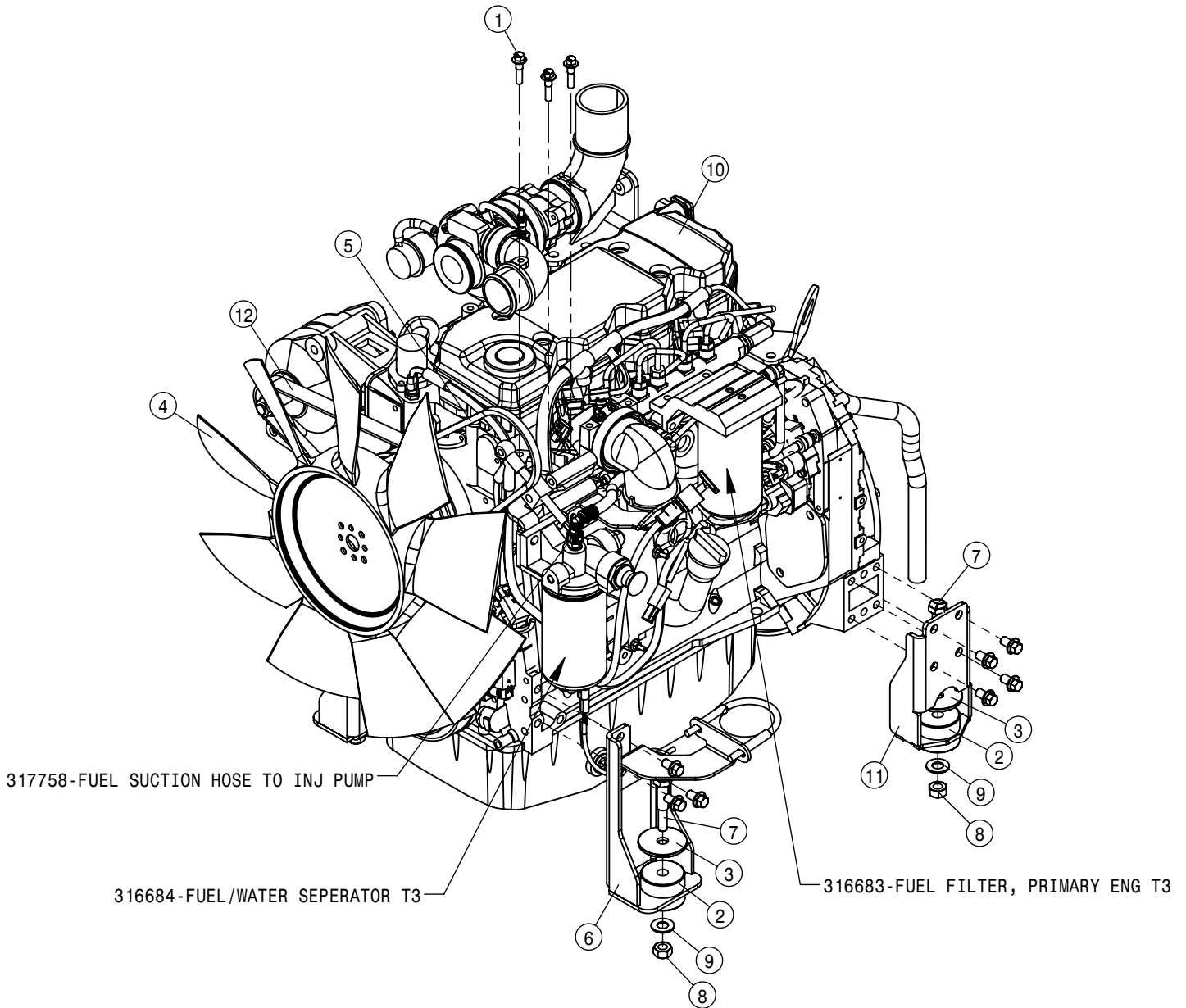

TIER-3 ENGINE ASSEMBLY			
DET	QTY	P/N	DESCRIPTION
1	3	19M9846	10-1.5 X 40 MHF8 CL10.9 ZF
2	2	311093	ISOLATOR
3	2	311095	SNUBBING WASH FOR 311093/094
4	1	316551	FAN, 24" CUMM QSB205, 2101 03
5	1	316851	BELT, GATES GREEN STRIPE 9447
6	1	316863	LH FRT ENG MT, MFM66-A
7	2	900339	5/8UNC X 3 1/4 HHCS GR5 MC
8	2	914010	5/8-11UNC STOVER NUT MC GR5
9	2	920005	SAE FLAT WASHER 5/8 MC
10	1	316030	QSB 4.5 T3 ENGINE, 204SP '15
11	1	316864	LH REAR ENG MT, MRM103-A
12	1	317386	SERPENTINE BELT, 204SP



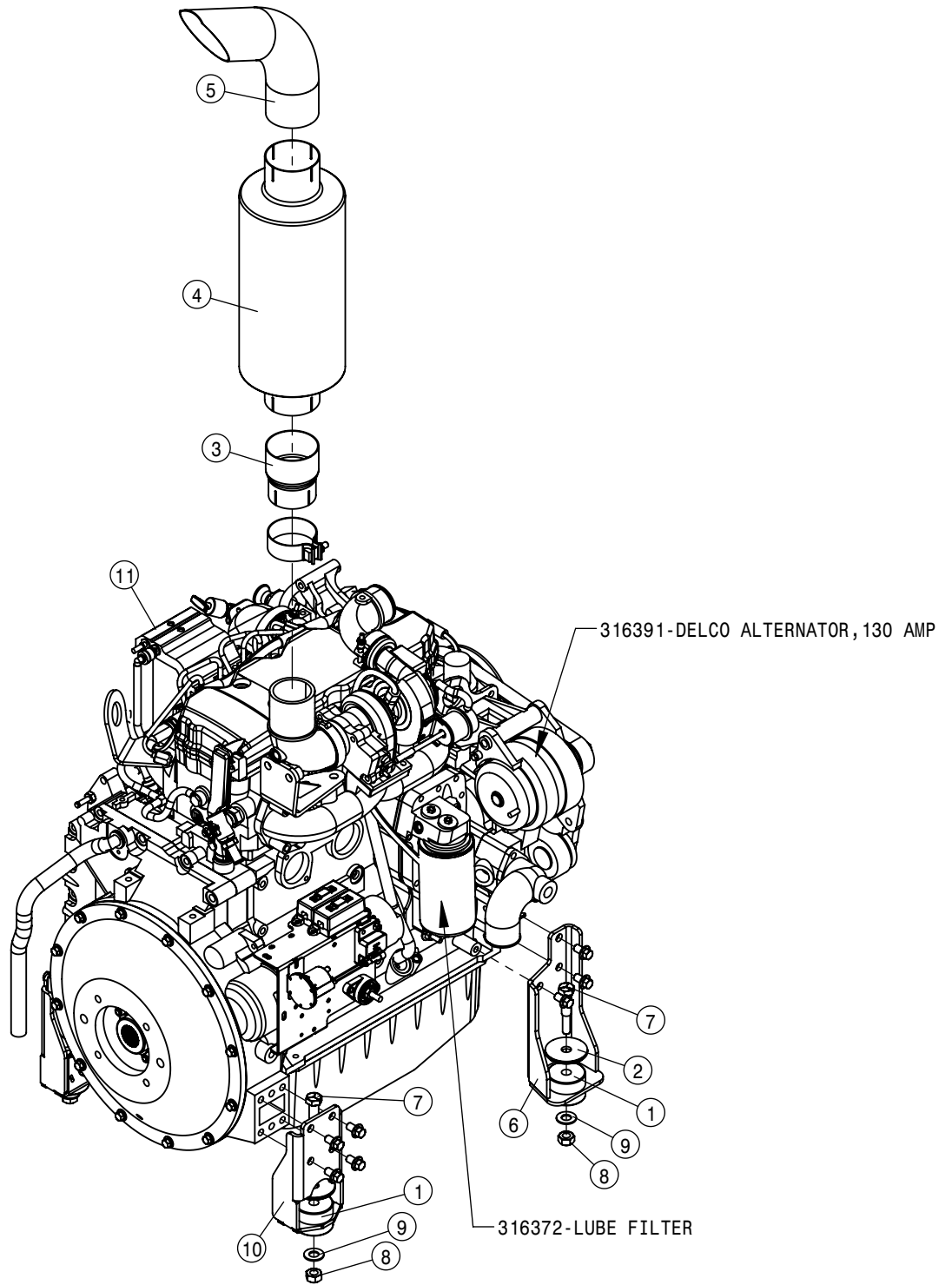

TIER-3 ENGINE ASSEMBLY			
DET	QTY	P/N	DESCRIPTION
1	2	311093	ISOLATOR
2	2	311095	SNUBBING WASH FOR 311093/094
3	1	311589	REDUCER, EXHAUST
4	1	311590	MUFFLER
5	1	311591	EXH PIPE STACK
6	1	316862	RH FRT ENG MT, MFM67-A
7	2	900339	5/8UNC X 3 1/4 HHCS GR5 MC
8	2	914010	5/8-11UNC STOVER NUT MC GR5
9	2	920005	SAE FLAT WASHER 5/8 MC
10	1	316005	RH REAR ENG MT, MRM107-A
11	1	316030	QSB 4.5 T3 ENGINE, 204SP '15

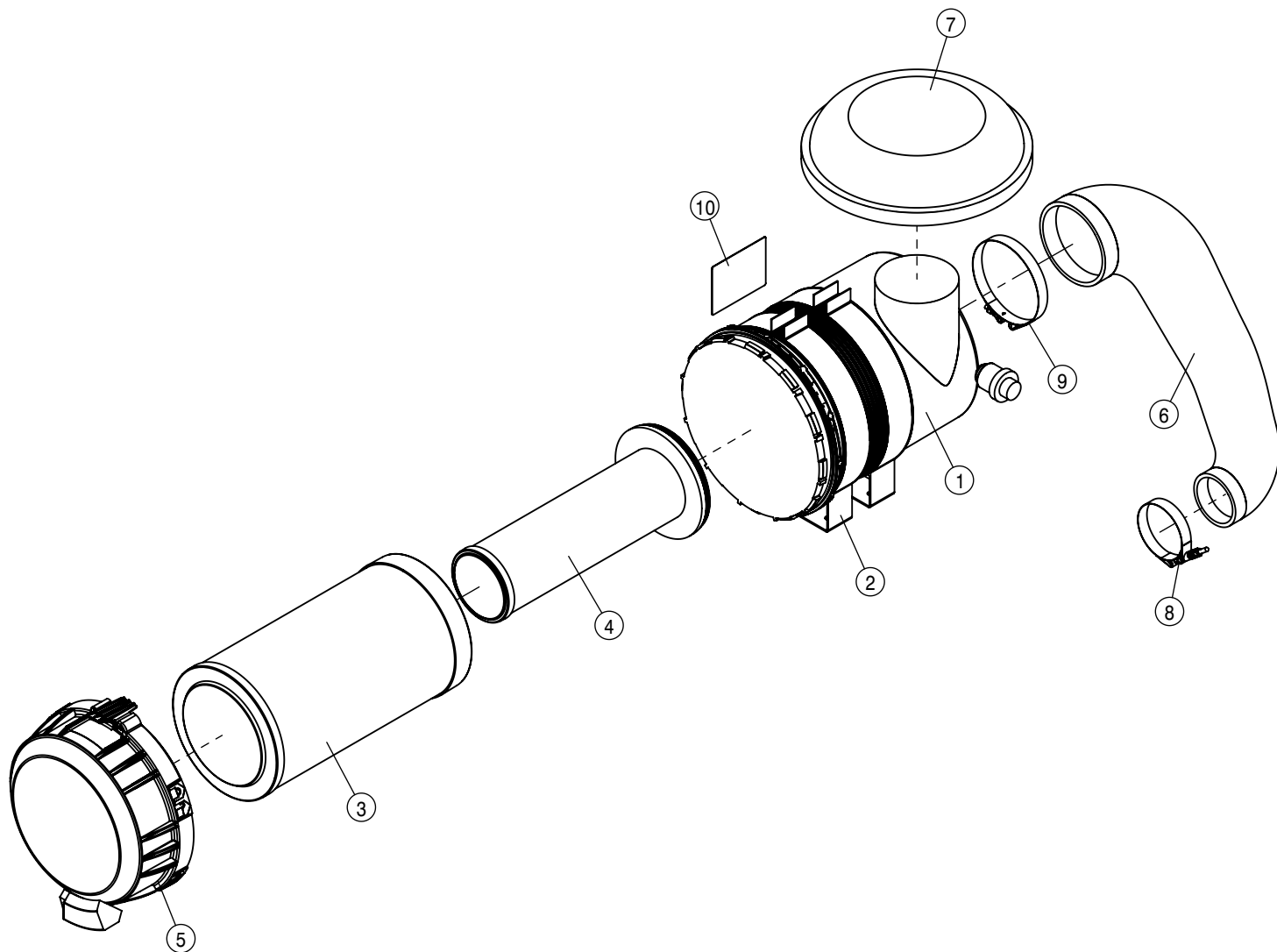

TIER-3 AIR CLEANER ASSEMBLY			
DET	QTY	P/N	DESCRIPTION
1	1	311528	AIR CLEANER, PLASTIC HSNG
2	2	311529	AIR CLEANER MT BAND FOR 311528
3	1	311530	PRIMARY ELEMENT FOR 311528
4	1	311531	SAFETY ELEMENT FOR 311528
5	1	311548	COVER ASSEMBLY FOR 311528
6	1	311585	AIR INTAKE HOSE, MOLDED
7	1	311588	WEATHER HOOD
8	1	520130	3.31/3.59 T-BOLT HOSE CLAMP SS
9	1	520136	5.31/5.59 T-BOLT HOSE CLAMP SS
10	1	650367	AIR FILTER INSTRUCTION DECAL

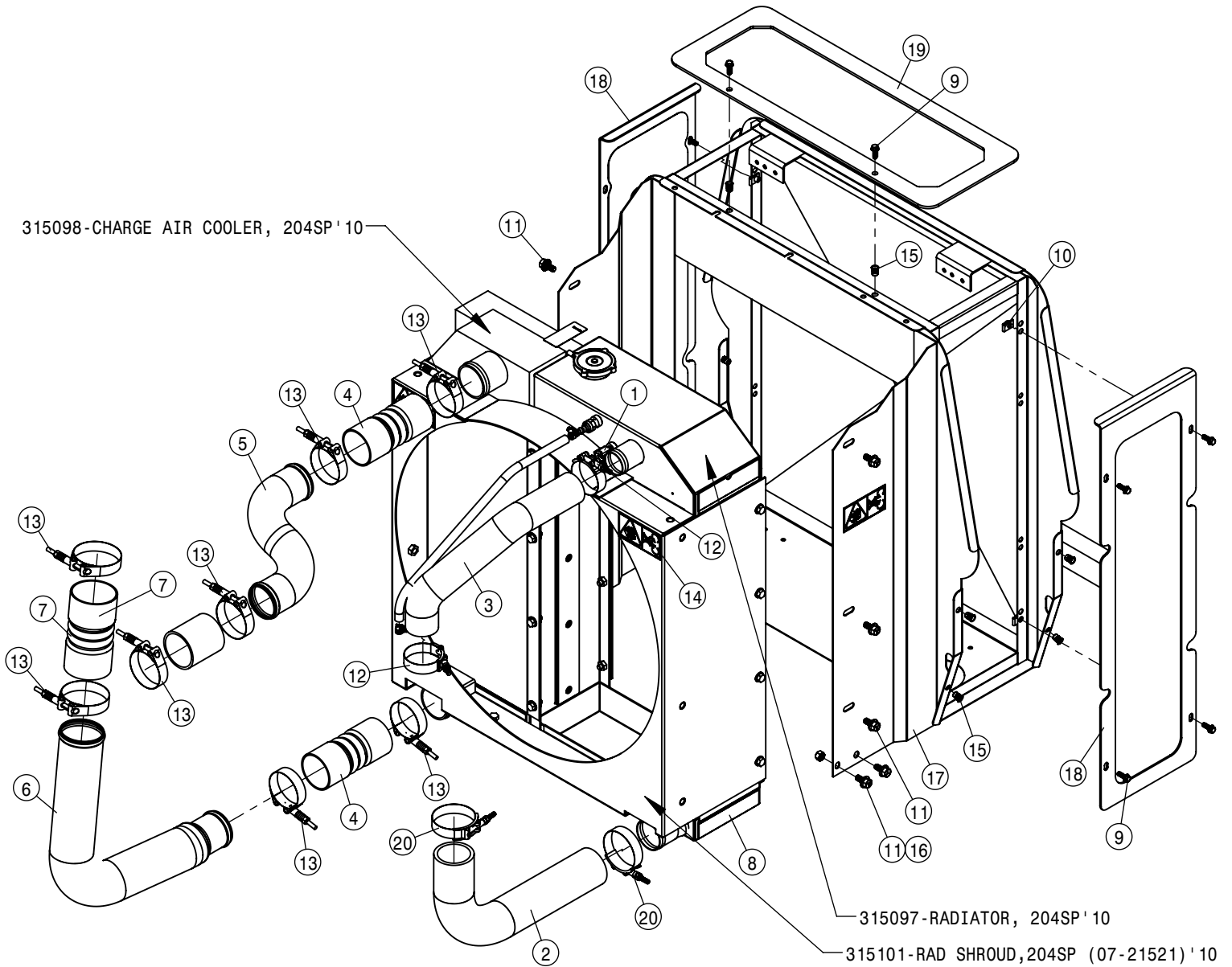

TIER-3 RADIATOR ASSEMBLY			
DET	QTY	P/N	DESCRIPTION
1	1	291935	RAD WATER LEVEL SENSOR,T3 ENG
2	1	311097	LOWER RAD HOSER,MCA189-B
3	1	311583	UPPER RAD HOSE,MCA195-A
4	2	311584	2.50 X 6.00 CAC HOSE
5	1	311586	CAC TUBE,HOT
6	1	311587	CAC TUBE, COLD
7	1	311592	3.00 X 6.00 CAC HOSE
8	1	315096	RAD, CAC, SHROUD KIT, 204SP
9	10	470118	1/4 UNC X 3/4 SER FLG BOLT
10	4	470386	1/4 -20 SPRING NUT LUG
11	10	470409	3/8UNC X 3/4 HHSFB GR5 MC
12	2	520141	2.31/2.62 T-BOLT HOSE CLAMP SS
13	8	520153	2.56/2.87 T-BOLT HOSE CLAMP SS
14	4	650434	DECAL, FAN BLADE WARNING
15	14	910127	1/4-20 NUTSERT .027-1.65 STL
16	4	914004	3/8UNC HEX STOVER NUT
17	1	362457	RAD OIL COOLER RAD MT, T3
18	2	362463	SIDE SCRNL WLD, INTAKE 204 T3
19	1	362467	TOP COOLING PKG WLD T3
20	2	520143	2.87/3.18 T-BOLT HOSE CLAMP SS

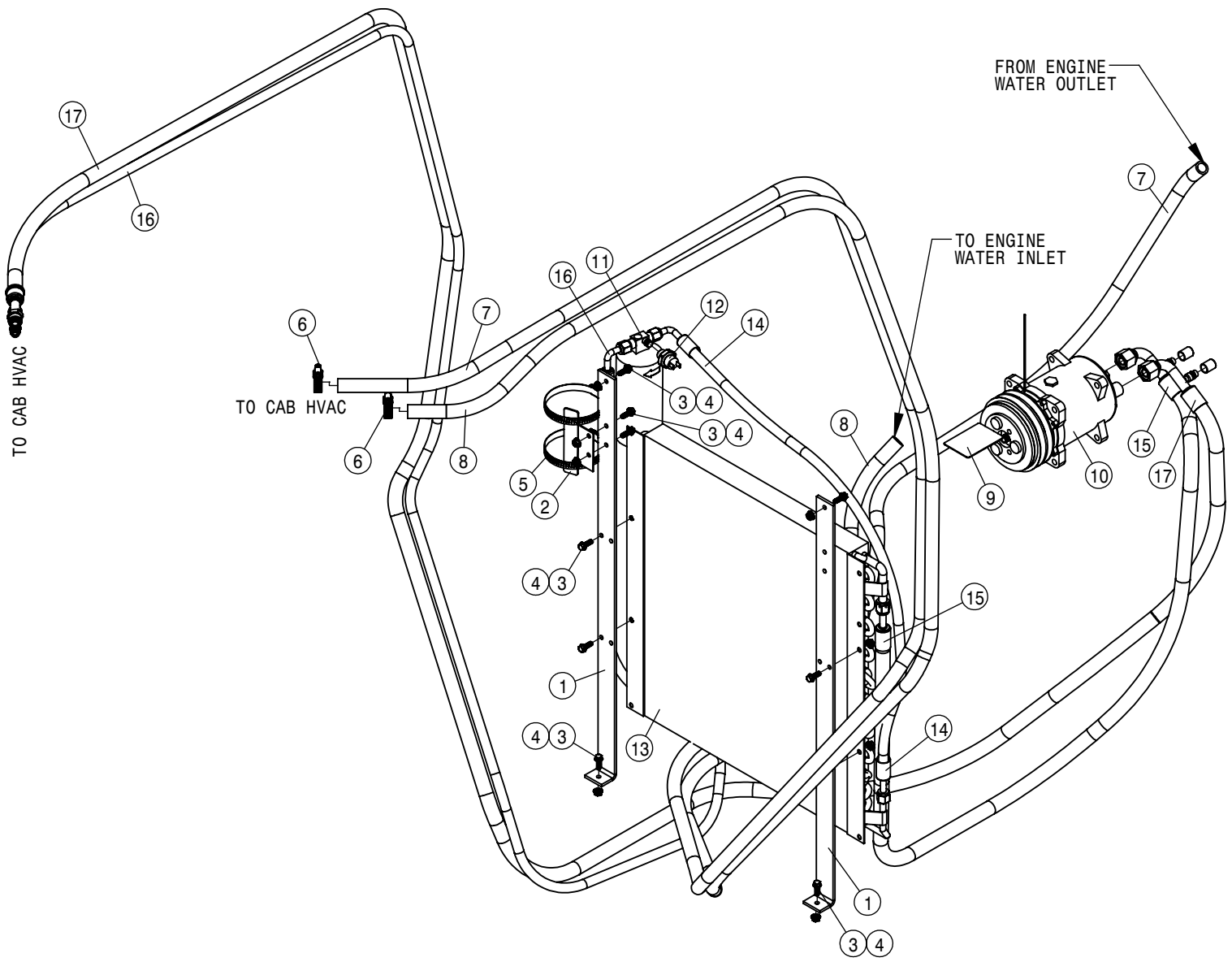

A/C AND HEATER LINES			
DET	QTY	P/N	DESCRIPTION
1	2	315036	CONDENSOR MTG BRKT 99
2	1	315038	DRYER MTG BRKT 284 99
3	10	470118	1/4 UNC X 3/4 SER FLG BOLT
4	10	470121	1/4 UNC SERR FLG LOCK NUT
5	2	520052	HOSE CLAMP NO 52 STAINLESS
6	2	520055	HOSE CLAMP NO 12 STAINLESS
7	1	601342	HOSE, 5/8 X 192 HEATER
8	1	601343	HOSE, 5/8 X 216 HEATER
9	1	650347	DECAL, NOTICE R134A, 2LB 12OZ
10	1	657403	A/C COMPSR, 180D PORTS TM15/12
11	1	657421	A/C RECEIVER/DRIER
12	1	657422	A/C BINARY SWITCH
13	1	657423	COIL, COND
14	1	657429	A/C HOSE ASSY, 5/16 X 44
15	1	657430	A/C HOSEASSY, 13/32 X 80
16	1	657431	A/C HOSE ASSY, 5/16 X 173
17	1	657432	A/C HOSE ASSY, 1/2 X 190.

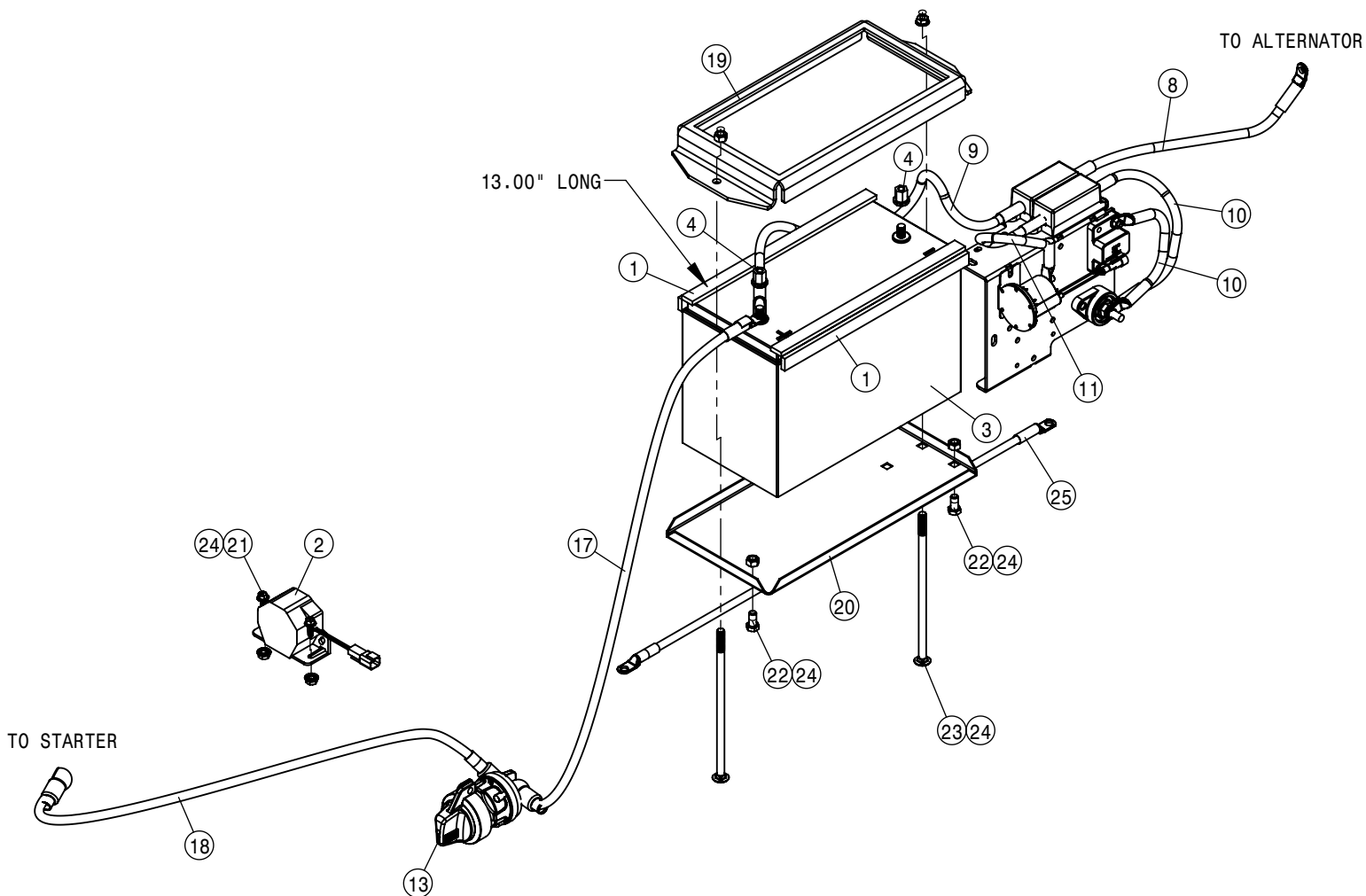

BATTERY BOX ASSEMBLY			
DET	QTY	P/N	DESCRIPTION
1	4	193022	STICKERTITE 1/4 X 3/4
2	1	290061	ALARM, BACKUP 107DBA LT DUTY
3	1	291013	BATTERY, 12V 925CCA, SS STUD
4	2	291205	BATTERY NUT, 3/8-16 SS CLSD CAP
NS	1	292520	BATT CABLE, RED 15' 2/0 .406-.406
NS	1	292526	BATT CABLE, BLK 26' 1/0 406-.406
NS	1	292527	BATT CABLE, RED 54' 4GA. 406-.406
8	1	292547	BATT CABLE, RED 15' 2GA. 343-.343
9	1	292548	BATT CABLE, RED 46' 2GA. 343-.406
10	2	292549	BATT CABLE, RED 8' 4GA. 343-.406
11	1	292550	BATT CABLE, RED 10.50' 4GA. 281-.343
NS	1	292551	BATT CABLE, BLK 22' 2GA .281-.406
13	1	292580	BATT DISCONNECT SWITCH, LOCKOUT
NS	1	293564	16GA BLK-291512-291590-36
NS	1	293970	SPD SENSOR HARNESS, DTS10 '10
NS	1	294263	204 T3 ENGINE HARNESS
17	1	294296	BATT CABLE, RED 44' 1/0. 406-.406
18	1	294297	BATT CABLE, RED 78' 1/0. 406-.406
19	1	341303	HOLD DOWN - BATTERY, 204
20	1	361149	BATTERY BOX 8300-8400 1981
21	2	470118	1/4UNC X 3/4 HHSFB GR5 MC
22	2	900128	3/8UNC X 3/4 HHCS GR5 MC
23	2	901150	3/8-16 X 9 CARRIAGE BOLT
24	6	470113	3/8-16UNC STOVER NUT MC GR5
25	1	292552	BATT CABLE, BLK 30' 4GA. 406-.406
NS	1	294003	HARNESS, ECM POWER 204SP '10

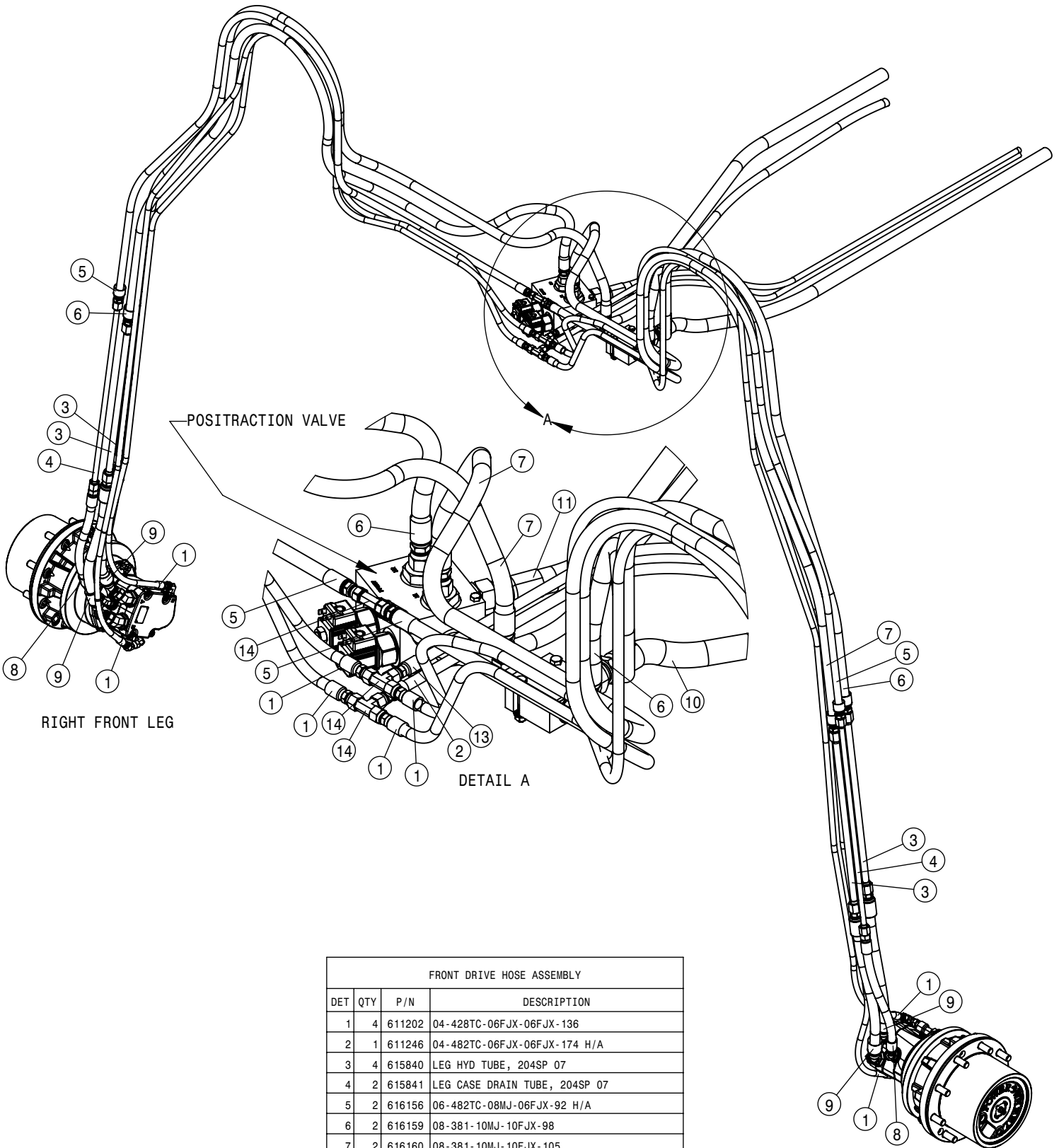

RIGHT FRONT LEG

DETAIL A

LEFT FRONT LEG

FRONT DRIVE HOSE ASSEMBLY			
DET	QTY	P/N	DESCRIPTION
1	4	611202	04-428TC-06FJX-06FJX-136
2	1	611246	04-482TC-06FJX-06FJX-174 H/A
3	4	615840	LEG HYD TUBE, 204SP 07
4	2	615841	LEG CASE DRAIN TUBE, 204SP 07
5	2	616156	06-482TC-08MJ-06FJX-92 H/A
6	2	616159	08-381-10MJ-10FJX-98
7	2	616160	08-381-10MJ-10FJX-105
8	2	616432	08-381-08MJ-08FJX45-15
9	4	616433	10-787TC-10MJ-10FJX45-17
10	1	616933	12-721-16FJX-16FJX-114 H/A
11	1	616934	12-721-16FJX-16FJX-117 H/A
12	1	617328	08-451TC-06FJX-08FJX-156 H/A
13	1	617336	04-451TC-06FJX-06FJX90-142 H/A
14	3	618019	9/16MJIC UNION TEE

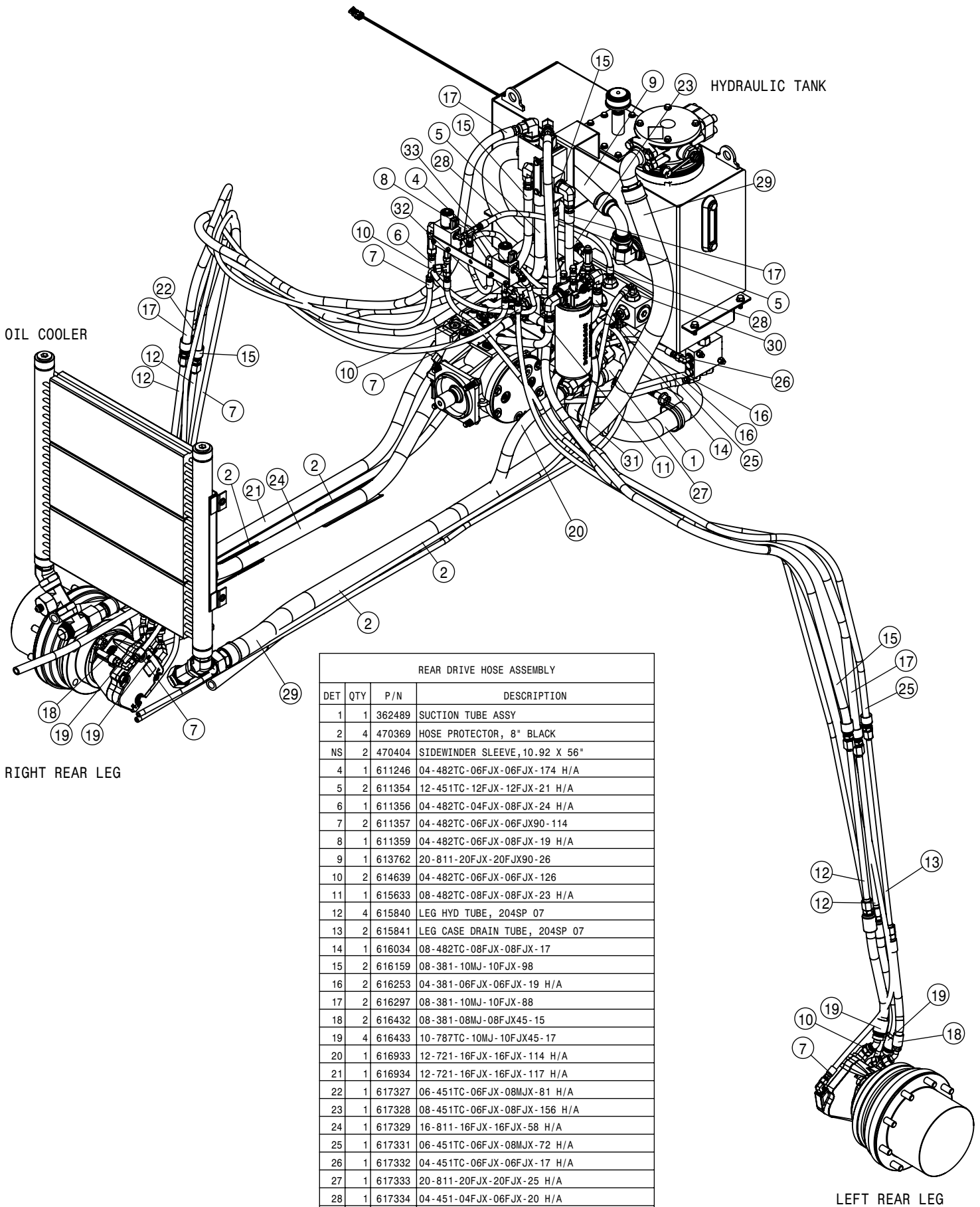

REAR DRIVE HOSE ASSEMBLY			
DET	QTY	P/N	DESCRIPTION
	1	362489	SUCTION TUBE ASSY
	4	470369	HOSE PROTECTOR, 8" BLACK
NS	2	470404	SIDEWINDER SLEEVE, 10.92 X 56"
	1	611246	04-482TC-06FJX-06FJX-174 H/A
	2	611354	12-451TC-12FJX-12FJX-21 H/A
	1	611356	04-482TC-04FJX-08FJX-24 H/A
	2	611357	04-482TC-06FJX-06FJX90-114
	1	611359	04-482TC-06FJX-08FJX-19 H/A
	1	613762	20-811-20FJX-20FJX90-26
	2	614639	04-482TC-06FJX-06FJX-126
	1	615633	08-482TC-08FJX-08FJX-23 H/A
	4	615840	LEG HYD TUBE, 204SP 07
	2	615841	LEG CASE DRAIN TUBE, 204SP 07
	1	616034	08-482TC-08FJX-08FJX-17
	2	616159	08-381-10MJ-10FJX-98
	2	616253	04-381-06FJX-06FJX-19 H/A
	2	616297	08-381-10MJ-10FJX-88
	2	616432	08-381-08MJ-08FJX45-15
	4	616433	10-787TC-10MJ-10FJX45-17
	1	616933	12-721-16FJX-16FJX-114 H/A
	1	616934	12-721-16FJX-16FJX-117 H/A
	1	617327	06-451TC-06FJX-08MJX-81 H/A
	1	617328	08-451TC-06FJX-08FJX-156 H/A
	1	617329	16-811-16FJX-16FJX-58 H/A
	1	617331	06-451TC-06FJX-08MJX-72 H/A
	1	617332	04-451TC-06FJX-06FJX-17 H/A
	1	617333	20-811-20FJX-20FJX-25 H/A
	1	617334	04-451-04FJX-06FJX-20 H/A
	1	617335	24-811-24FJX-24FLANGE90-89
	1	617336	04-451TC-06FJX-06FJX90-142 H/A
	1	617339	32-811-32FJX-32FJX-21 H/A
	1	617340	04-451TC-04FJX-08FJX-13 H/A
	1	617338	12-811-12FJX-12FJX-15 H/A

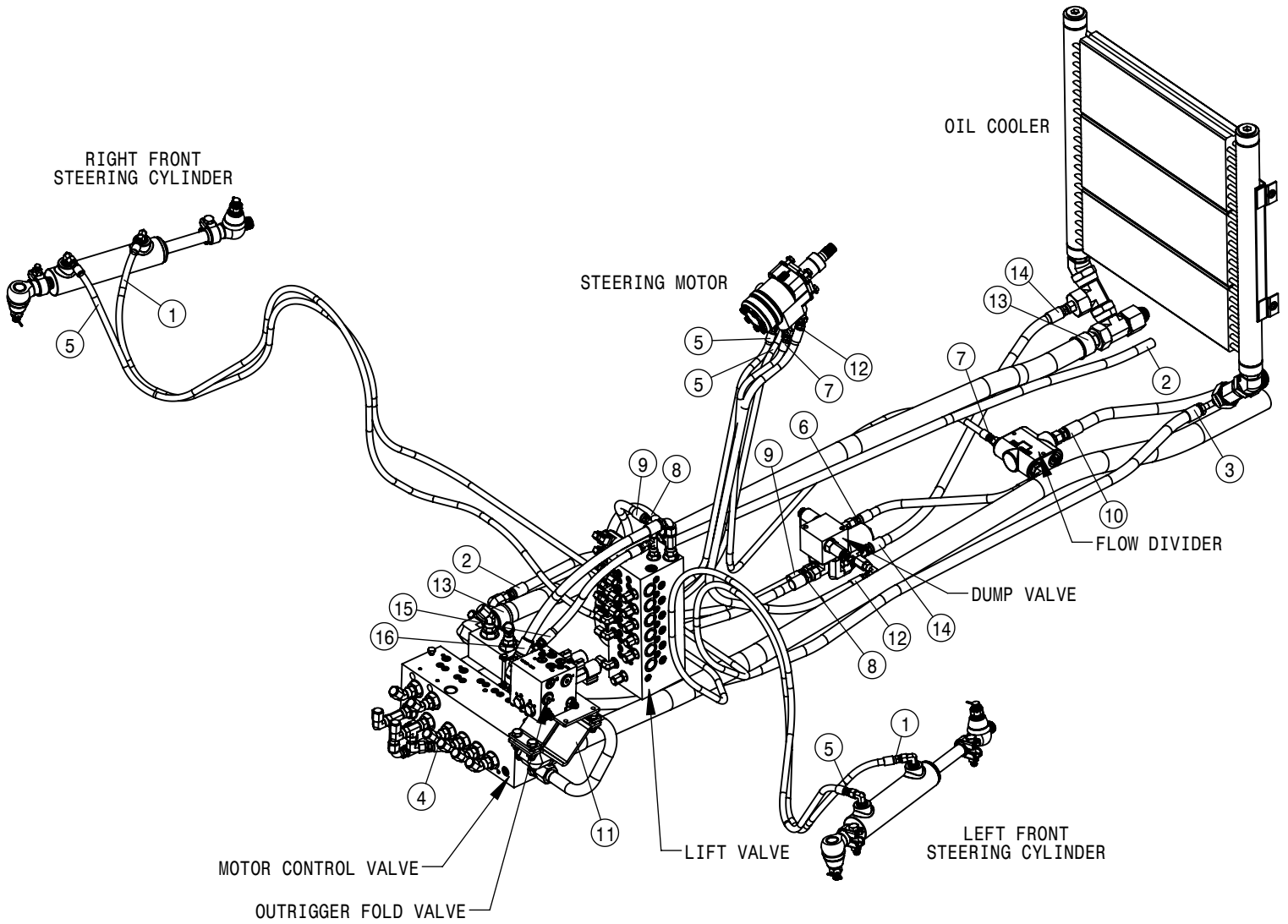

FRONT AUX HYDRAULIC HOSE ASSEMBLY			
DET	QTY	P/N	DESCRIPTION
1	1	611246	04-482TC-06FJX-06FJX-174 H/A
2	1	611353	08-451TC-08FJX-08FJX90-157 H/A
3	1	611355	10-451TC-08FJX-10FJX90-90 H/A
4	1	617254	08-451TC-08FJX-08FJX90-21 H/A
5	2	614639	04-482TC-06FJX-06FJX-126
6	1	615473	06-482TC-06FJX-08FJX-18 H/A
7	1	615727	04-482TC-06FJX-06FJX-75 H/A
8	1	616007	08-482TC-08FJX-10FJX-50
9	1	616008	06-482TC-08FJX-06FJX90-52 H/A
10	1	616147	10-482TC-10FJX-10FJX-89 H/A
11	1	616257	20-381-20FJX-20FJX-144 H/A
12	1	617330	06-451TC-6FJX-06FJX-46 H/A
13	1	617337	20-811-20FJX-20FJX-73 H/A
14	1	617341	08-451TC-08FJX-8FJX-36 H/A
15	1	616117	06-451TC-06FJX-06FJX-17 H/A
16	1	616505	08-451TC-08FJX-08FJX90-24 H/A



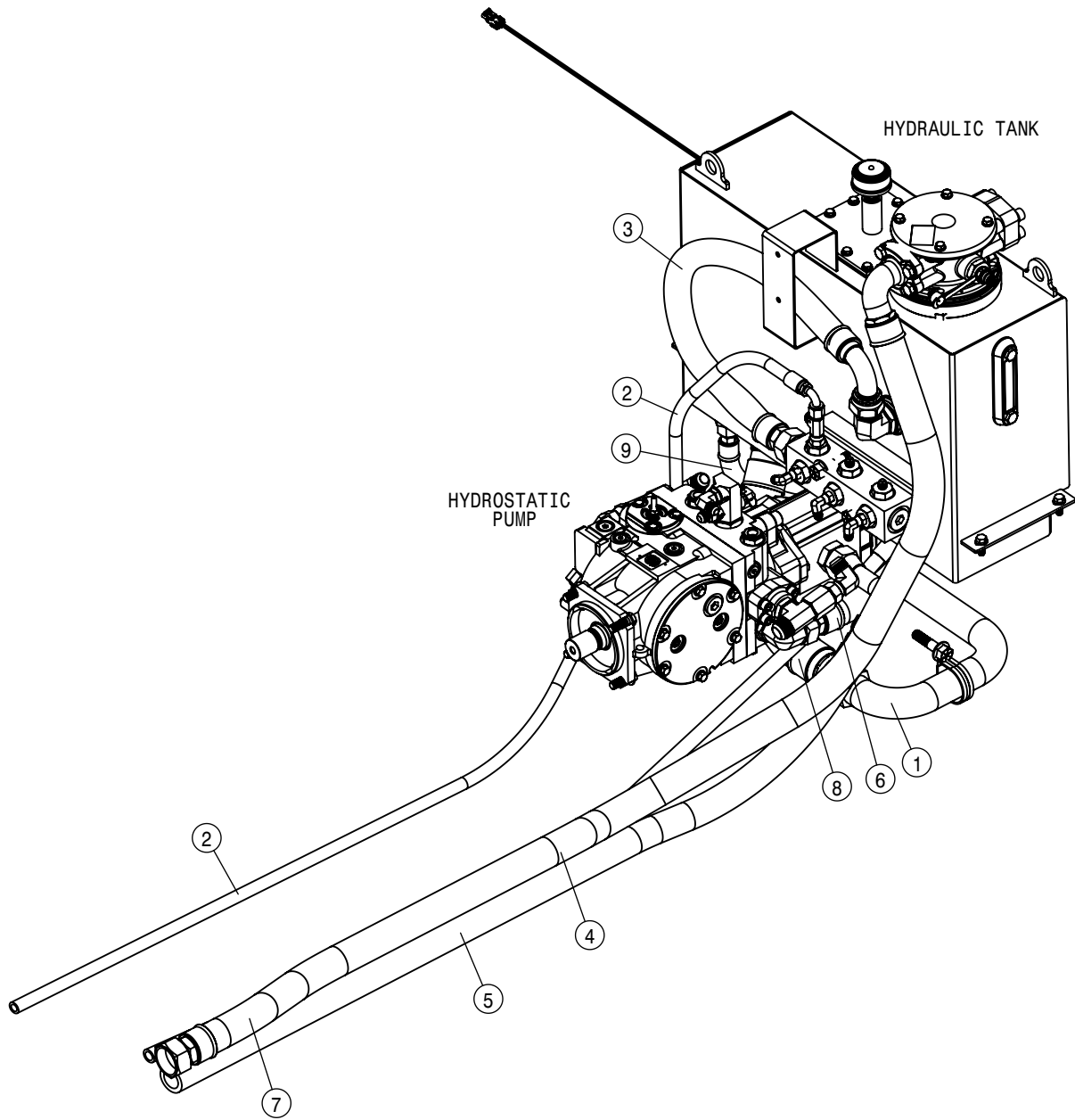

REAR AUX HYDRAULIC HOSE ASSEMBLY			
DET	QTY	P/N	DESCRIPTION
1	1	362489	SUCTION TUBE ASSY
2	1	611353	08-451TC-08FJX-08FJX90-157 H/A
3	1	613762	20-811-20FJX-20FJX90-26
4	1	616147	10-482TC-10FJX-10FJX-89 H/A
5	1	616257	20-381-20FJX-20FJX-144 H/A
6	1	617333	20-811-20FJX-20FJX-25 H/A
7	1	617335	24-811-24FJX-24FLANGE90-89
8	1	617339	32-811-32FJX-32FJX-21 H/A
9	1	617338	12-811-12FJX-12FJX-15 H/A

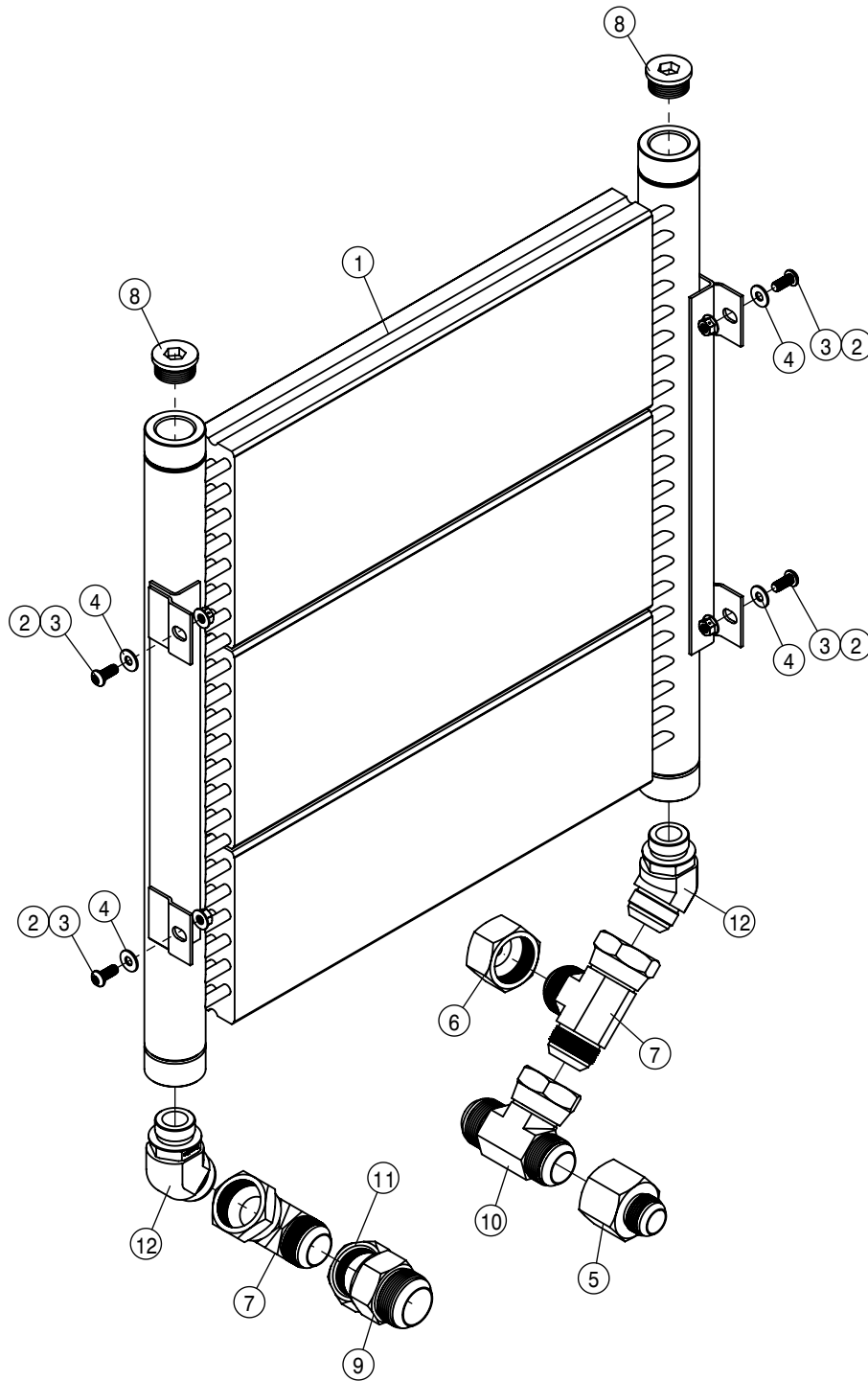

OIL COOLER ASSEMBLY			
DET	QTY	P/N	DESCRIPTION
1	1	317581	OIL COOLER BLISSFIELD 87007
2	4	470570	5/16UNC HEX FLG CNTR LOCK NUT
3	4	472375	5/16UNC X 3/4 BUTN CAP SCR BLK
4	4	483038	1/4 REGULAR FLAT WASHER
5	1	618547	1 5/8FJIC-1 5/16MJIC ADPTR
6	1	618723	1 5/8FJIC-3/4MJIC ADPTR
7	2	618726	1 5/8FJ SW RUN TEE-1 5/8MJ
8	2	618758	1 5/16MOR PLUG, HEX SOCKET
9	1	618762	1 5/8FJIC-1 7/8MJIC ADPTR
10	1	618843	1 5/8FJX BRANCH TEE-1 5/8MJ
11	1	618917	1 5/8FJIC-7/8MJIC ADPTR
12	2	618969	1 5/8MJIC-45-1 5/16MOR

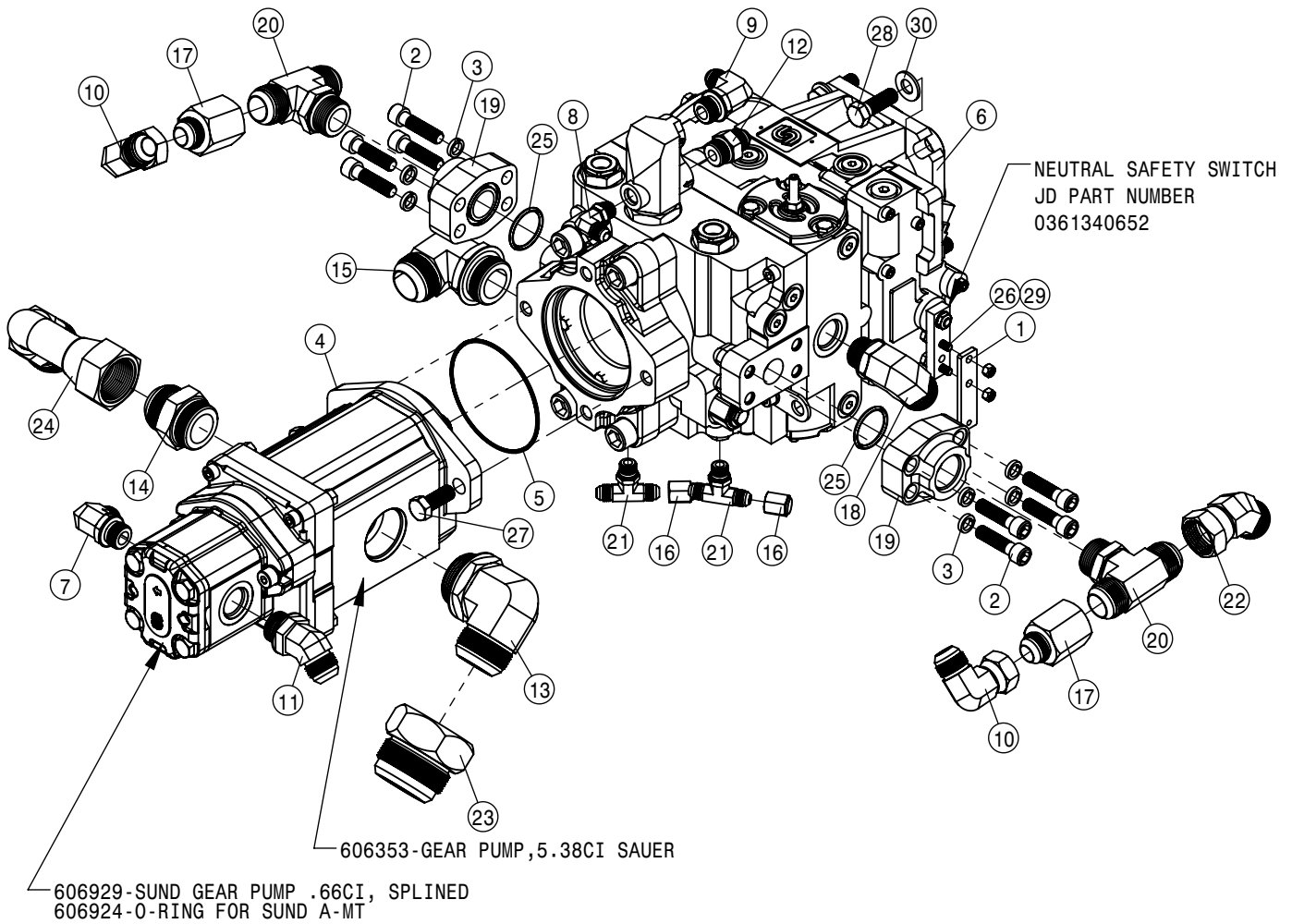

HYDROSTATIC PUMP ASSEMBLY			
DET	QTY	P/N	DESCRIPTION
1	1	316160	PUMP CONT LEVER EXT 280 CUMM
2	8	470188	7/16-14 X 1 3/4 SKTHD CAP SCR
3	8	470189	7/16 HC LOCK WASH FOR 618598
4	1	606352	TANDEM PUMP, 606353 & 606929
5	1	606357	O-RING, B-MT, 3.737ID X .103CS
6	1	607572	SUND 100CC PUMP, 23T B-MT /FILT
7	1	611128	7/8MJIC-90-7/8MOR LBO
8	1	618119	9/16MJIC-90-9/16MOR LBO
9	1	618183	3/4MJIC-90-7/8MOR LBO
10	2	618191	1 1/16MJ-90-1 1/16FJ SWIV LBO
11	1	618313	1 1/16MJIC-45-1 1/16MOR LBO
12	1	618327	3/4MJIC-7/8MOR ADPTR
13	1	618432	1 7/8MJIC-90-1 7/8MOR LBO
14	1	618472	1 5/8MJIC-1 5/8MOR ADPTR
15	1	618477	1 5/8MJIC-90-1 5/8MOR LBO

HYDROSTATIC PUMP ASSEMBLY			
DET	QTY	P/N	DESCRIPTION
16	2	618531	9/16FJIC CAP NUT
17	2	618541	1 5/16FJIC-1 1/16MJIC ADPTR
18	1	618576	1 5/16MJIC-90-1 1/16MOR LBO
19	2	618598	1" 4-BOLT FLG X 1 5/16 FOR
20	2	618599	1 5/16MOR BRANCH TEE-1 5/16MJIC
21	2	618629	9/16MOR BRANCH TEE-9/16MJIC
22	1	618630	1 5/16MJ-45-1 5/16FJ SWIV LBO
23	1	618839	1 7/8FJIC - 2 1/2MJIC ADPTR
24	1	618851	1 5/8MJIC-90-1 5/8FJX TUBE FTG
25	2	870219	BUNA ORING 1 5/16 X 1 9/16
26	2	900003	1/4UNC X 1" HEX BOLT
27	2	900264	1/2UNC X 1 1/4 HEX BOLT
28	4	900265	1/2UNC X 1 1/2 HEX BOLT
29	2	914000	1/4UNC HEX STOVER NUT
30	4	920004	1/2 SAE FLAT WASHER

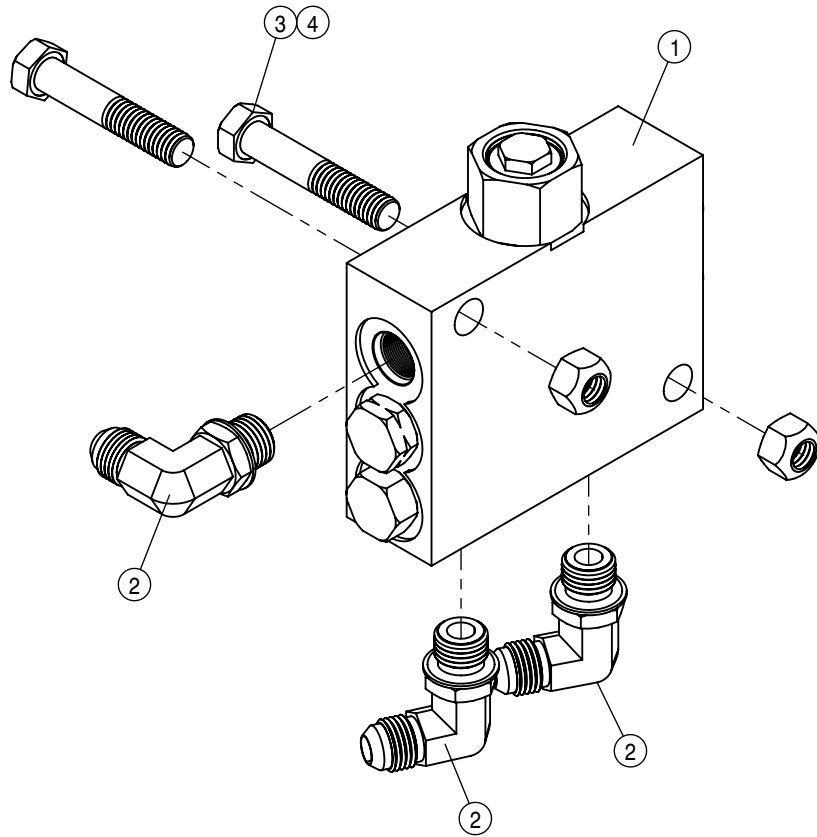

LOOP FLUSHING VALVE ASSEMBLY			
DET	QTY	P/N	DESCRIPTION
1	1	610580	REMOTE FLUSHING VALVE, SUND
2	3	618119	9/16MJIC-90-9/16MOR LBO
3	2	900133	3/8UNC X 2" HEX BOLT
4	2	914004	3/8UNC HEX STOVER NUT

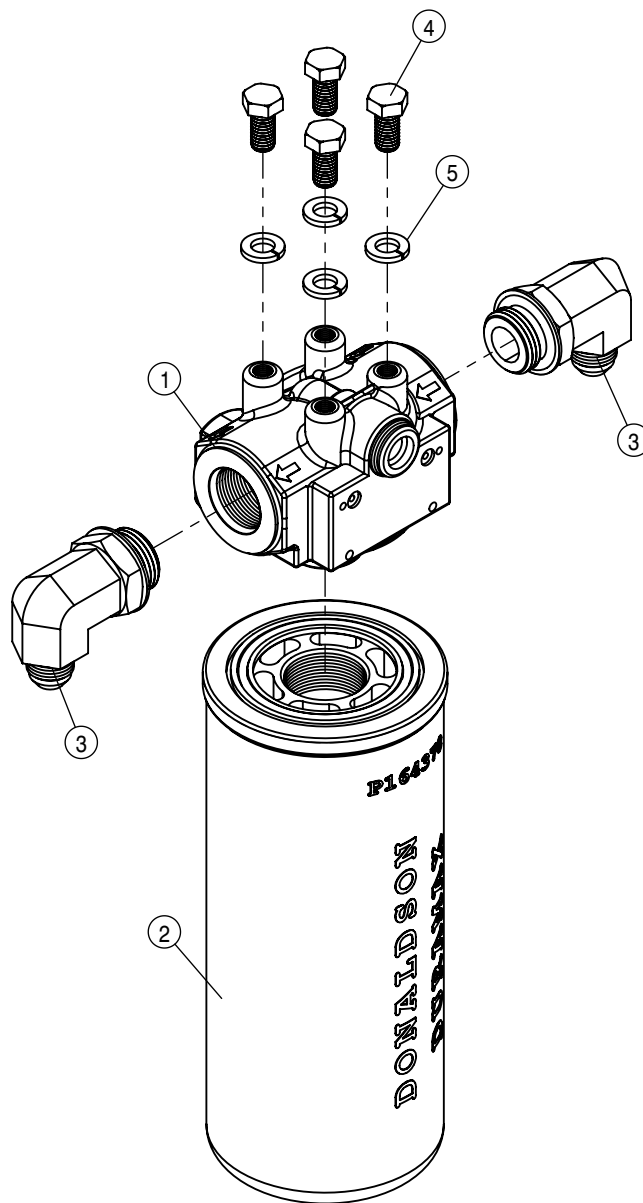

HI-PRESSURE FILTER ASSEMBLY				
DET	QTY	P/N	DESCRIPTION	
1	1	605608	HYD FILTER HEAD, DONALDSON	
2	1	605609	HYD FILTER ELEMENT, DONALDSON	
3	2	618474	3/4MJC-90-1 1/16MOR LBO	
4	4	900128	3/8UNC X 3/4 HEX BOLT	
5	4	920502	3/8 LOCK WASHER	

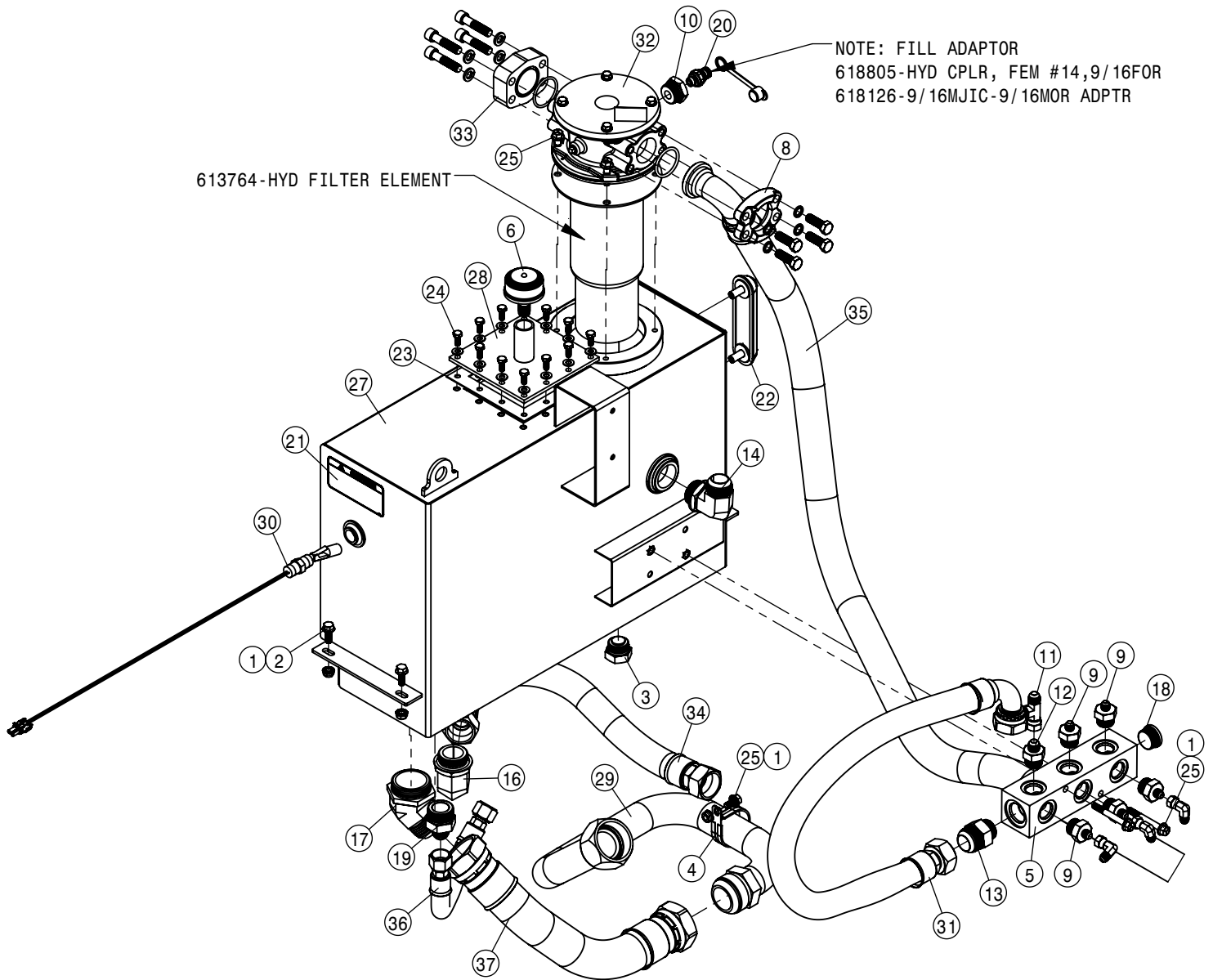

HYDRAULIC TANK ASSEMBLY			
DET	QTY	P/N	DESCRIPTION
1	7	470087	3/8-16UNC HEX FLG NUT SER MC GR5
2	4	470460	3/8 X 1" SERR FLG BOLT
3	1	470471	1 5/16MOR PLUG, MAGNETIC
4	1	520172	CUSH CLAMP,2 1/2"D-3/4W LOOP
5	1	606467	DTS-RETURN MANIFOLD
6	1	611052	FILLER BREATHER 3/4NPT
7	1	618255	DUST CAP/PLUG FOR 618804/805
8	1	618299	1.50 SPLIT FLANGE KIT #61
9	5	618344	9/16MJIC-1 1/16MOR ADPTR
10	1	618397	1 5/16MOR-9/16FOR ADPTR
11	1	618451	3/4FJIC SW RUN TEE-3/4MJIC
12	1	618469	3/4MJIC- 1 1/16MOR ADPTR
13	1	618471	1 5/8MJIC-1 5/16MOR ADPTR
14	1	618477	1 5/8MJIC-90-1 5/8MOR LBO
15	3	618618	9/16MJIC-90-9/16FJIC SWIV LBO
16	1	618704	1 5/8MJIC-90-1 7/8MOR LBO
17	1	618746	2 1/2MJIC-45-2 1/2MORB LBO
18	1	618758	1 5/16MOR PLUG, HEX SOCKET
19	1	618819	1 1/16MJIC-1 5/8MOR ADPTR

HYDRAULIC TANK ASSEMBLY			
DET	QTY	P/N	DESCRIPTION
20	1	618870	HYD CPLR, MALE #14 9/16MOR
21	1	650296	CAUTION DECAL
22	1	701367	SIGHT GAUGE
23	1	763039	HYD MTR MTG PLT GSKT
24	12	900064	5/16UNC X 3/4" HEX BOLT
25	7	900504	3/8UNC X 1 1/2 HHSFB GR5 MC
26	12	920001	5/16 SAE FLAT WASHER
27	1	317411	WLD HYD RES, 204 T3, 2015
28	1	317614	WLD, HYD PLT
29	1	362489	SUCTION TUBE ASSY
30	1	470350	LIQUID LEVEL SWITCH ASSY,1/2NP
31	1	613762	20-811-20FJX-20FJX90-26
32	1	613763	HYD FILTER ASSY, 204
33	1	617196	1.50 SPLIT FLANGE PLUG KIT #61
34	1	617333	20-811-20FJX-20FJX-25 H/A
35	1	617335	24-811-24FJX-24FLANGE90-89
36	1	617338	12-811-12FJX-12FJX-15 H/A
37	1	617339	32-811-32FJX-32FJX-21 H/A

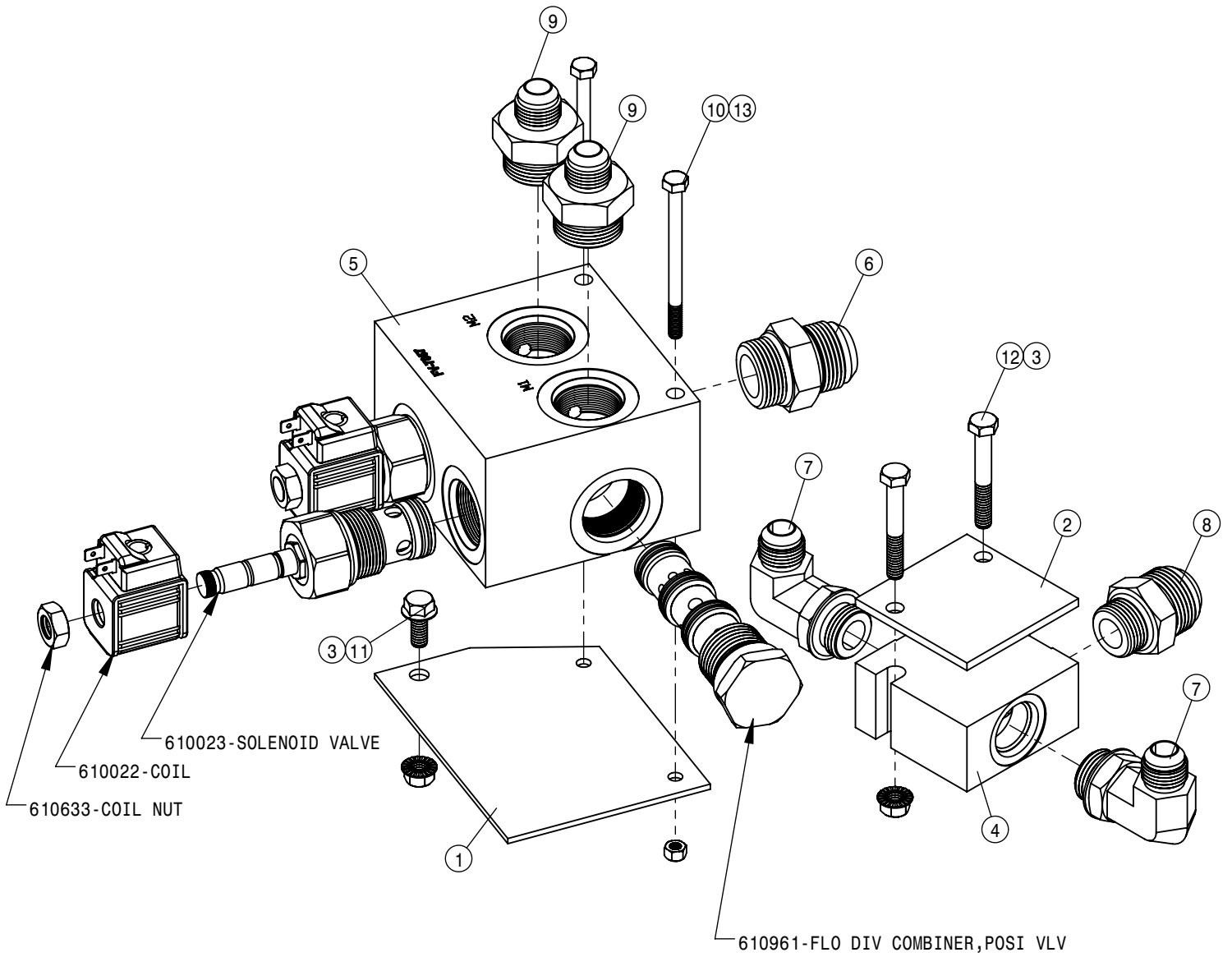

FRONT POSITRACTION VALVE ASSEMBLY			
DET	QTY	P/N	DESCRIPTION
1	1	341849	POSITRACTION VALVE MT 200
2	1	343187	FRT RETURN MNFLD MT,204/SP 08
3	3	470113	5/16UNC SERR FLG LOCK NUT
4	1	606356	1 1/16FOR MANIIFOLD,3 #12PORTS
5	1	610586	POSITRACTION VLV,ALUM,88SP60G
6	1	618186	1 5/16MJIC-1 5/16MOR ADPTR
7	2	618535	7/8MJIC-90-1 1/16MOR LBO
8	1	618558	1 5/16MJIC-1 1/16MOR ADPTR
9	2	618601	7/8MJIC-1 5/16MOR ADPT
10	2	900012	1/4UNC X 3 1/2 HEX BOLT
11	1	900064N	5/16UNC X 3/4" SER FLG BOLT SS
12	2	900086	5/16UNC X 2 1/4 HEX BOLT
13	2	914000	1/4UNC HEX STOVER NUT

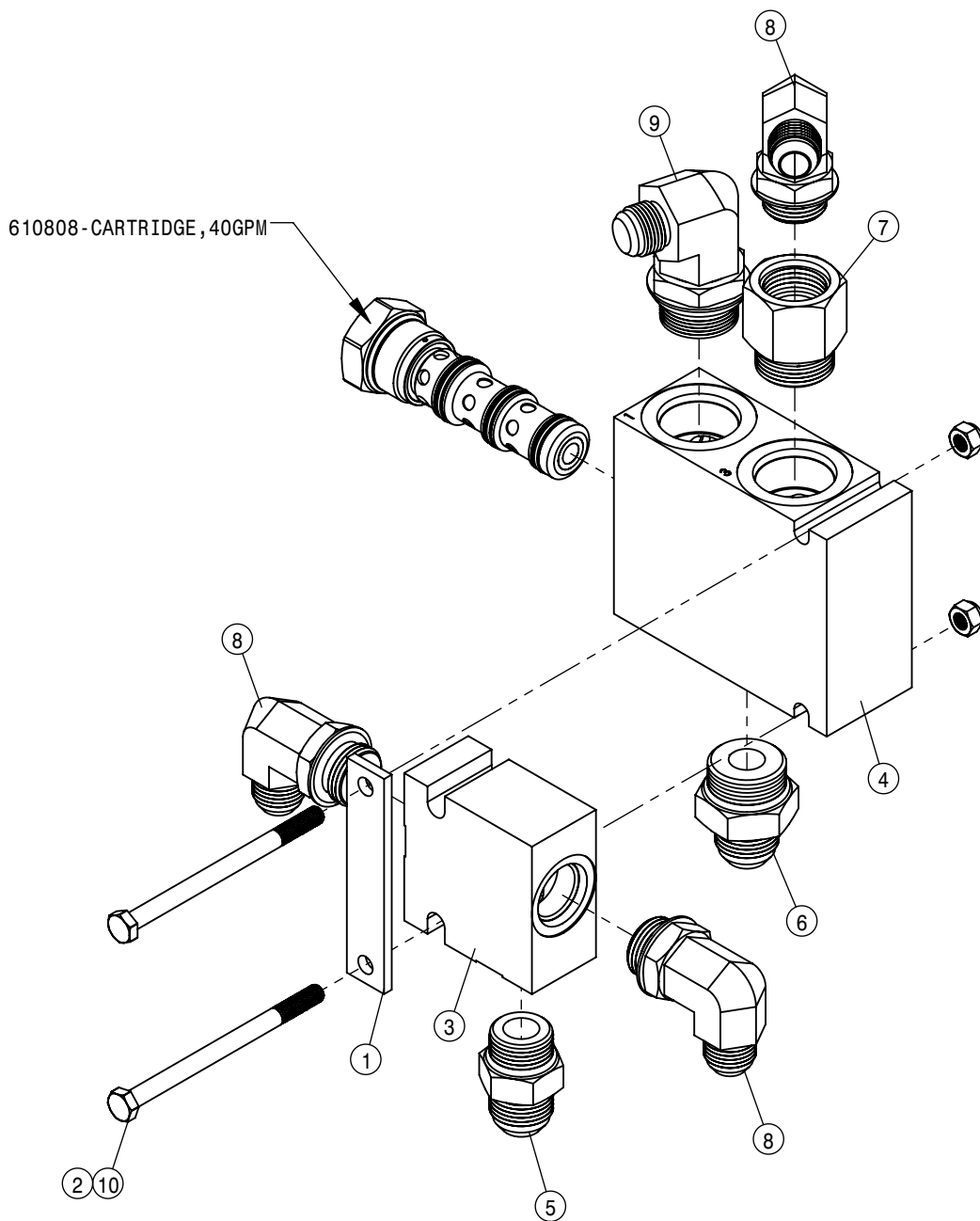

REAR POSITRACTION VALVE ASSEMBLY			
DET	QTY	P/N	DESCRIPTION
1	1	314843	TEE KEEPER, TRAC VLV 200 89
2	2	473001	5/16UNC HEX NUT, NYLOC
3	1	606356	1 1/16FOR MANIFOLD, 3 #12PORTS
4	1	610609	TRACTION VLV, STL, 66S, 40GPM
5	1	611127	1 1/16MJIC-1 1/16MOR ADPTR
6	1	618308	1 1/16MJIC-1 5/16MOR ADPTR
7	1	618312	1 5/16MOR-1 1/16FOR ADPTR
8	3	618535	7/8MJIC-90-1 1/16MOR LBO
9	1	618589	7/8MJIC-90-1 5/16MOR LBO
10	2	900078	5/16UNC X 4 1/2 HEX BOLT



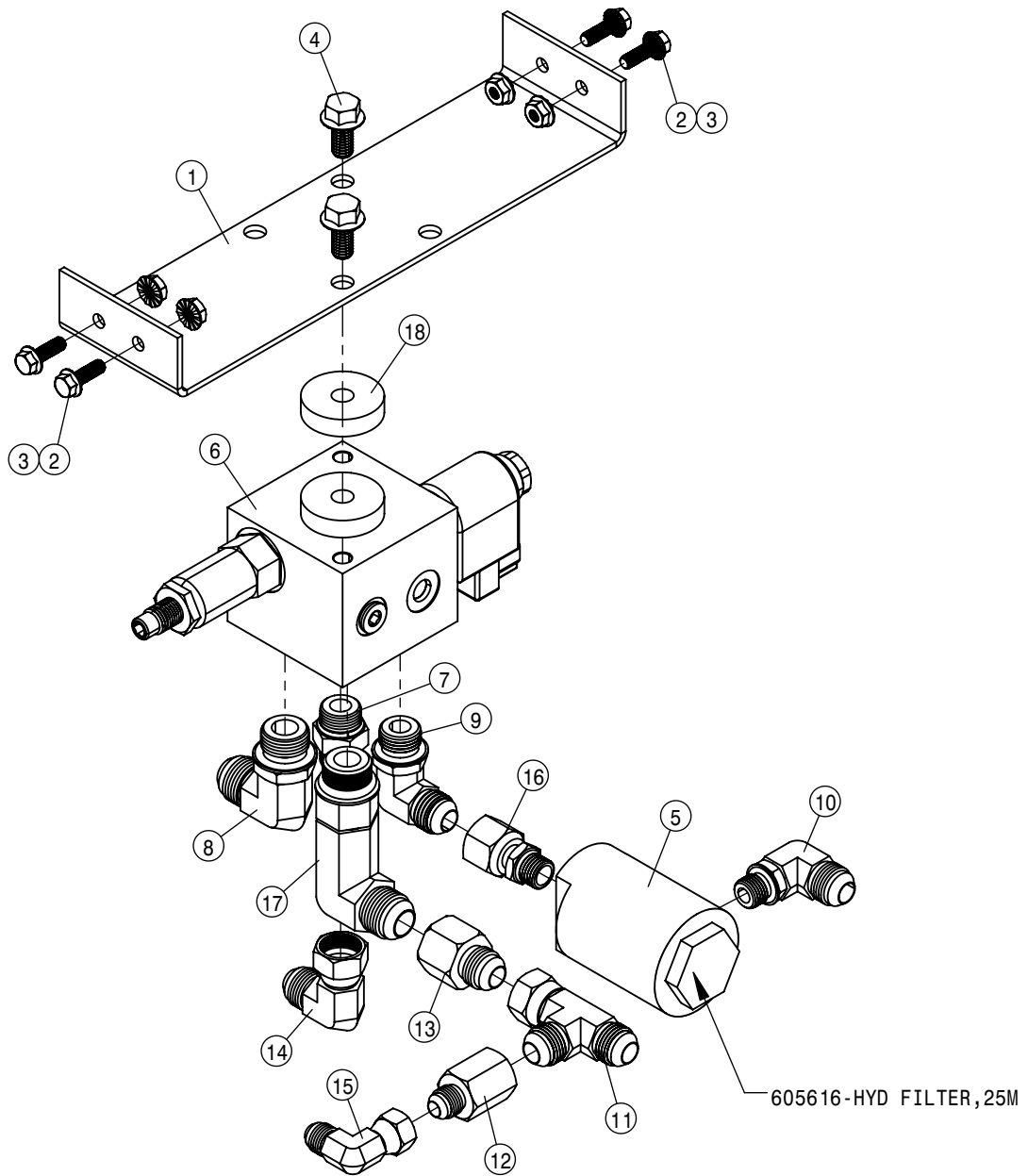

DUMP VALVE ASSEMBLY			
DET	QTY	P/N	DESCRIPTION
1	1	003100	DUMP VALVE MT 204 08
2	4	470118	1/4 UNC X 3/4 SER FLG BOLT
3	4	470121	1/4 UNC SERR FLG LOCK NUT
4	2	470409	3/8UNC X 3/4" SERR FLG BOLT
5	1	605615	HYD FILTER, INLINE 25M 9/16 FOR
6	1	606330	DUMP MANIF VALVE SAUER
7	1	611125	3/4MJIC-3/4MOR ADPTR
8	1	611128	7/8MJIC-90-7/8MOR LBO
9	1	618241	3/4MJIC-90-3/4MOR LBO
10	1	618249	3/4MJIC-90-9/16MOR LBO
11	1	618451	3/4FJIC SW RUN TEE-3/4MJIC
12	1	618482	3/4FJIC-9/16MJIC ADPTR
13	1	618523	7/8FJIC-3/4MJIC ADPTR
14	1	618609	3/4MJIC-90-3/4FJIC SWIV LBO
15	1	618618	9/16MJIC-90-9/16FJIC SWIV LBO
16	1	618692	3/4FJIC SWIV-9/16MOR ADPTR
17	1	618774	7/8 MJIC-90-7/8 MOR LG LBO
18	2	748501	RUBBER WASH .38 X .406 X 1.50

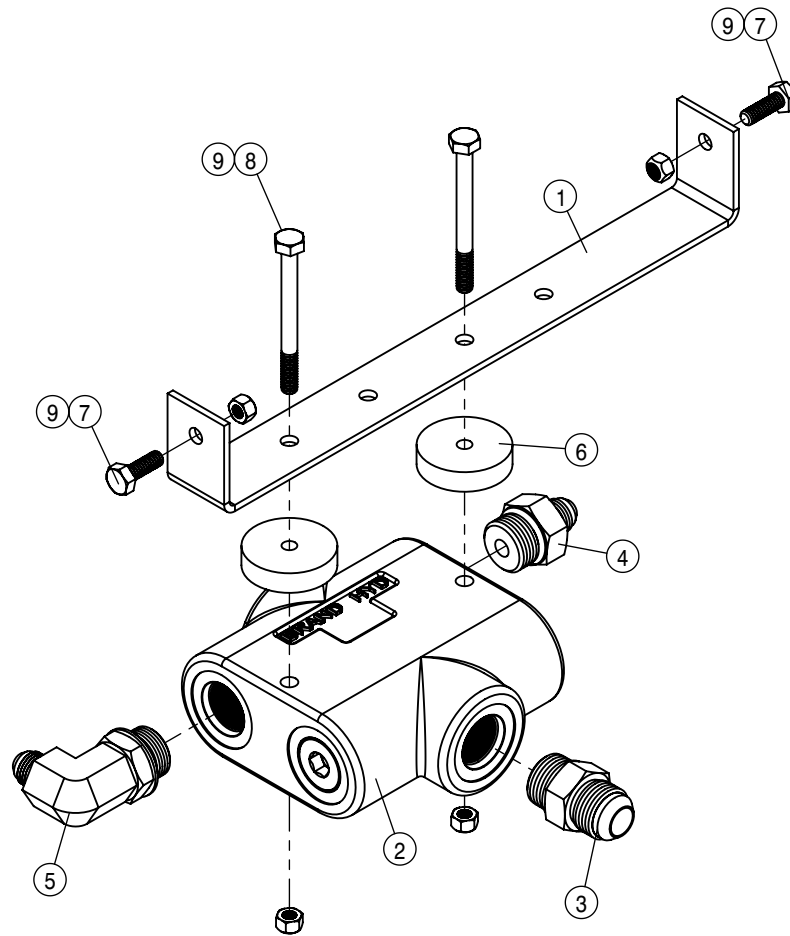

FLOW DIVIDER VALVE ASSEMBLY				
DET	QTY	P/N	DESCRIPTION	
1	1	341774	FLOW DIVIDER MT 280	89
2	1	607504	FLO DIV B50 2-8GPM 7/8 FOR	
3	1	611126	7/8MJIC-7/8MOR ADPTR	
4	1	618310	9/16MJIC-7/8MOR ADPTR	
5	1	618600	9/16MJIC-90-7/8MOR LBO	
6	2	748500	RUBER WASH 3/8X1/4IDX1 1/2 OD	
7	2	900002	1/4UNC x 3/4 HEX BOLT	
8	2	900009	1/4UNC X 2 3/4 HEX BOLT	
9	4	914000	1/4UNC HEX STOVER NUT	

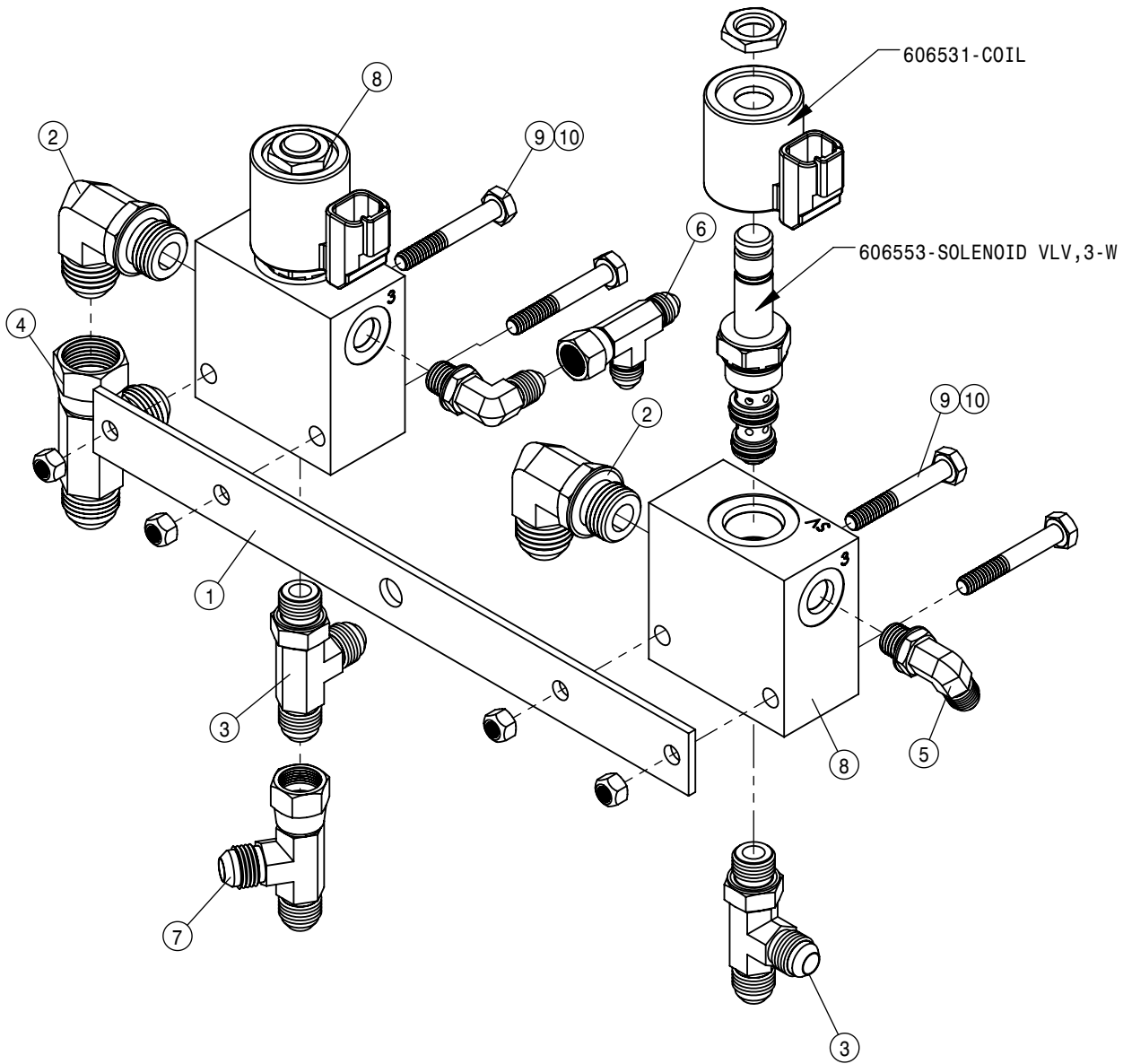

BRAKE AND SHIFT VALVE ASSEMBLY			
DET	QTY	P/N	DESCRIPTION
1	1	610797	BRAKE/SHIFT SOL VLV MT
2	2	618241	3/4MJIC-90-3/4MOR LBO
3	2	618444	9/16MOR RUN TEE-9/16MJIC
4	1	618451	3/4FJIC SW RUN TEE-3/4MJIC
5	2	618473	7/16MJIC-90-7/16MOR LBO
6	1	618485	7/16FJIC SW RUN TEE-7/16MJIC
7	1	618486	9/16FJIC SW RUN TEE-9/16MJIC
8	2	701625	ASSY, BRAKE/LADDER VALVE
9	4	900006	1/4UNC X 1 3/4 HEX BOLT
10	4	914000	1/4UNC HEX STOVER NUT

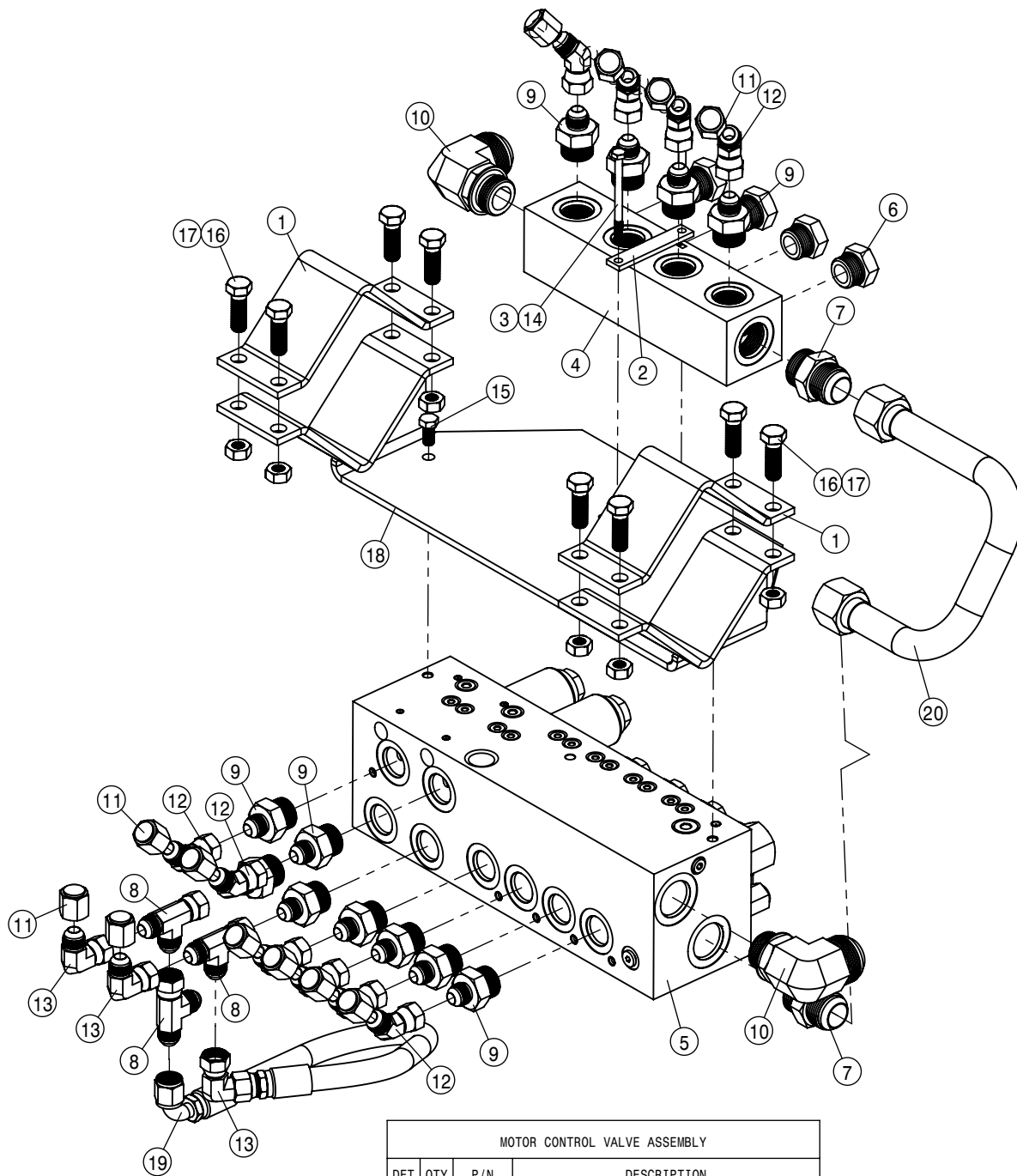

MOTOR CONTROL VALVE ASSEMBLY			
DET	QTY	P/N	DESCRIPTION
1	2	438324	75IN OUTGR BRACE CLAMP (PAINT)
2	1	439116	MTR CTRL VLV MT KEEPER, 204 07
3	2	470121	1/4 UNC SERR FLG LOCK NUT
4	1	606029	RETURN MANIFOLD BLOCK, STS 03
5	1	606262	MTR CONTROL ELECT VLV, SAUER 07
6	4	610186	1 1/16MOR PLUG, HEX HEAD
7	2	618186	1 5/16MJIC-1 5/16MOR ADPTR
8	3	618451	3/4FJIC SW RUN TEE-3/4MJIC
9	12	618469	3/4MJIC- 1 1/16MOR ADPTR
10	2	618476	1 5/8MJIC-90-1 5/16MOR LBO
11	12	618532	3/4FJIC CAP NUT
12	10	618590	3/4MJIC-45-3/4FJIC SWIV LBO
13	3	618609	3/4MJIC-90-3/4FJIC SWIV LBO
14	2	900011	1/4UNC X 3 1/4 HEX BOLT
15	2	900128	3/8UNC X 3/4 HEX BOLT
16	8	900265	1/2UNC X 1 1/2 HEX BOLT
17	8	914008	1/2 UNC HEX STOVER NUT
18	1	439114	MTR CTRL VLV MT WLD, 204 07
19	1	617254	08-451TC-08FJX-08FJX90-21 H/A
20	1	615799	MTR CTRL RET TUBE ASSY, 204 07

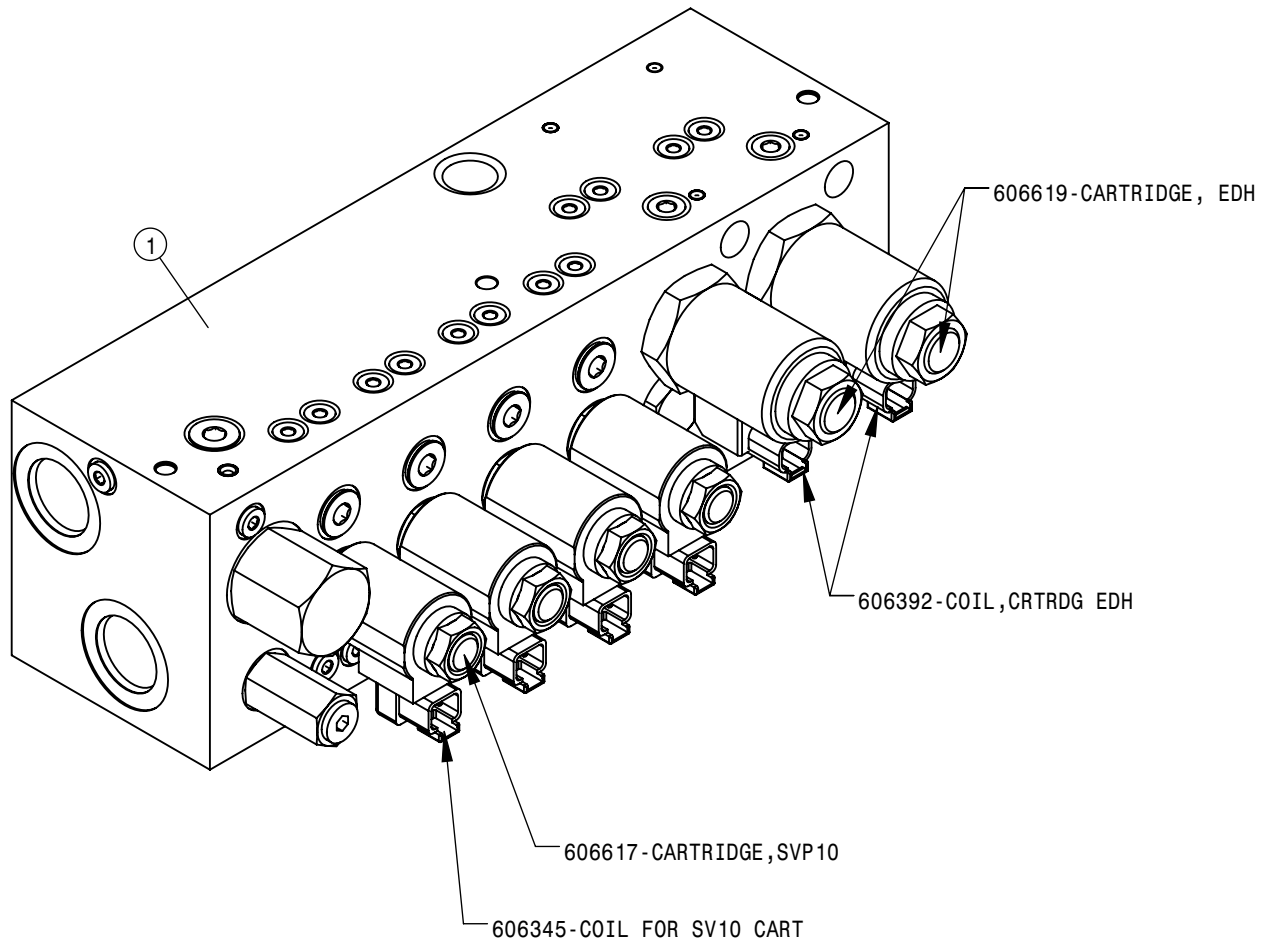

MOTOR CONTROL VALVE (REPAIR PARTS)			
DET	QTY	P/N	DESCRIPTION
1	1	606262	MTR CONTROL ELECT VLV, SAUER 07

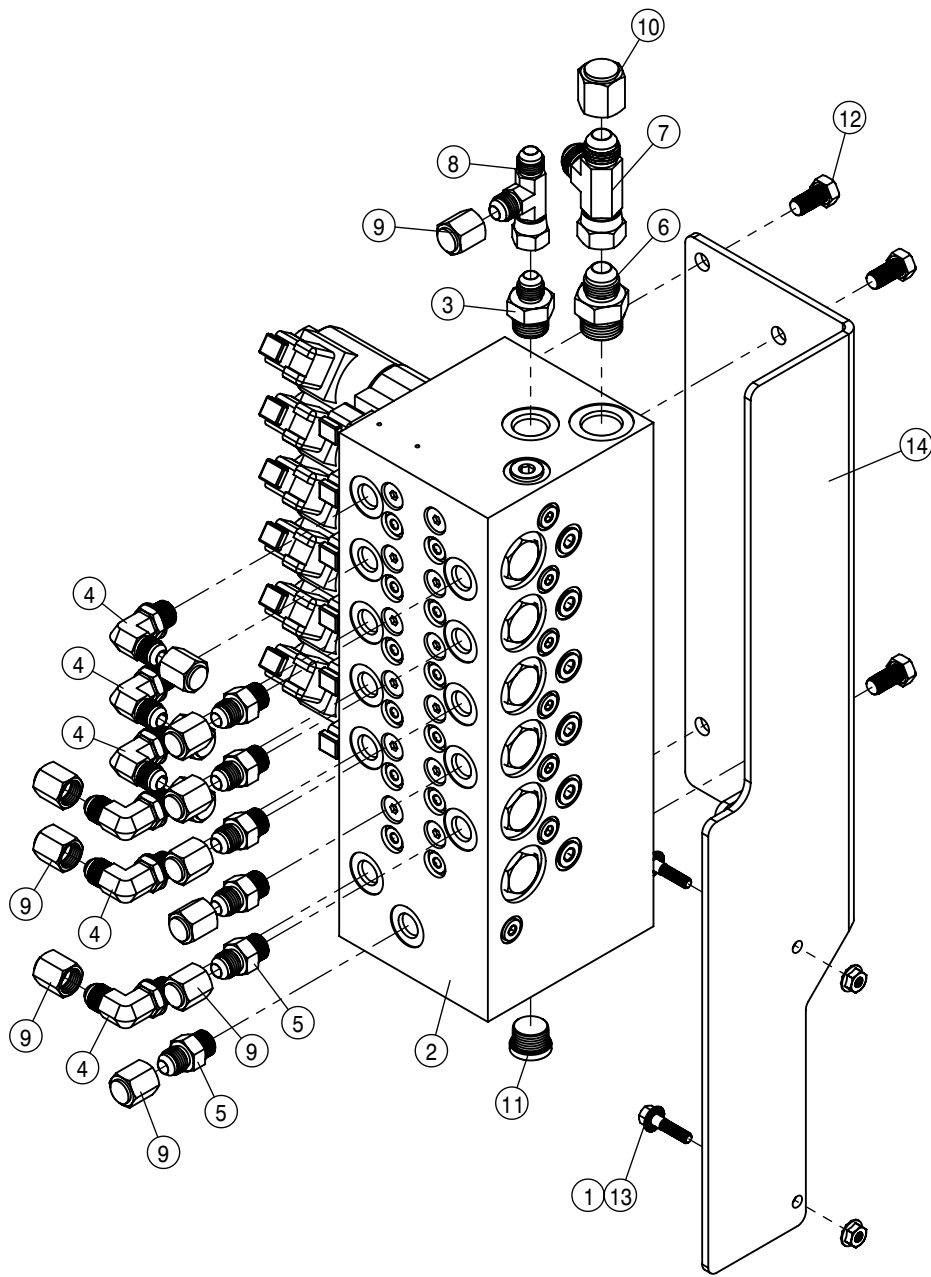

LIFT VALVE ASSEMBLY			
DET	QTY	P/N	DESCRIPTION
1	2	470121	1/4 UNC SERR FLG LOCK NUT
2	1	606285	LIFT VALVE,STS COMBO, SAUER
3	1	618109	9/16MJIC-3/4MOR ADPTR
4	6	618119	9/16MJIC-90-9/16MOR LBO
5	6	618126	9/16MJIC-9/16MOR ADPTR
6	1	618327	3/4MJIC-7/8MOR ADPTR
7	1	618451	3/4FJIC SW RUN TEE-3/4MJIC
8	1	618486	9/16FJIC SW RUN TEE-9/16MJIC
9	13	618531	9/16FJIC CAP NUT
10	1	618532	3/4FJIC CAP NUT
11	1	618755	3/4MOR PLUG, HEX SOCKET
12	4	900128	3/8UNC X 3/4 HEX BOLT
13	2	910124	1/4UNC X 1 HHSFB SS
14	1	003101	LIFT VALVE MT WLD 204 08

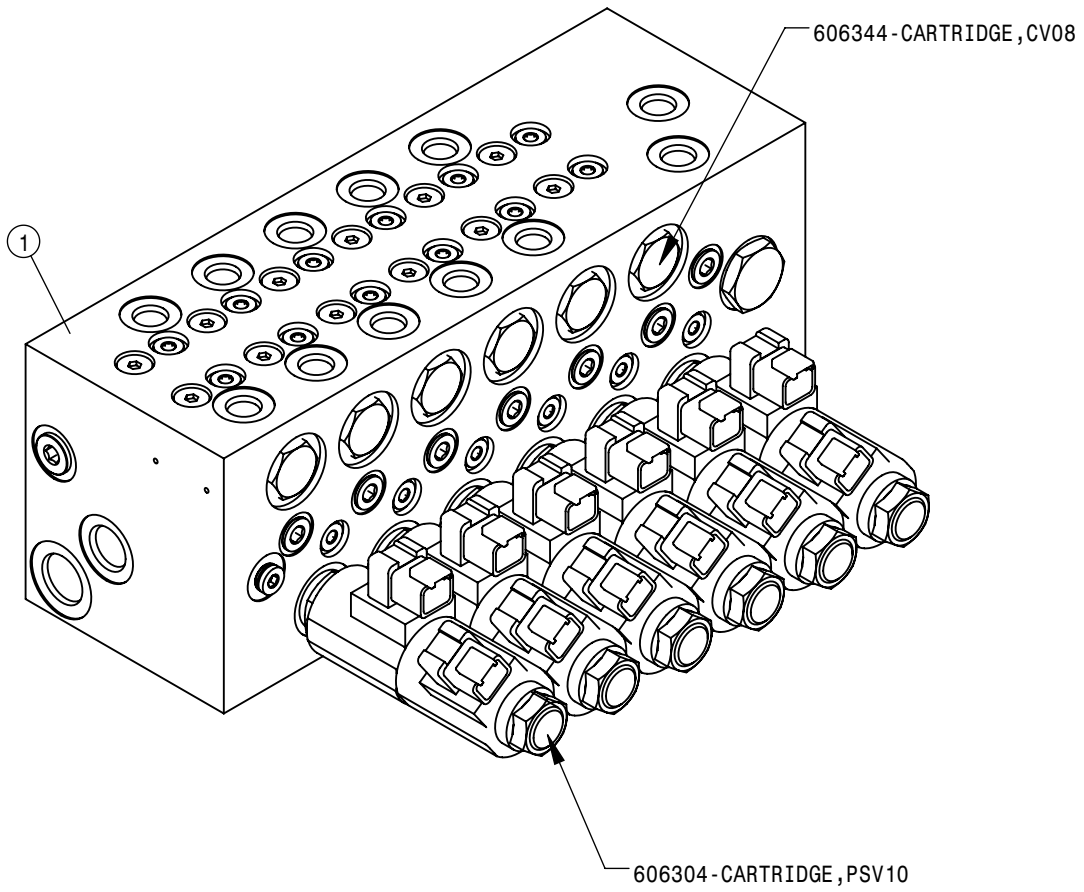

LIFT VALVE (REPAIR PARTS)			
DET	QTY	P/N	DESCRIPTION
1	1	606285	LIFT VALVE,STS COMBO,SAUER

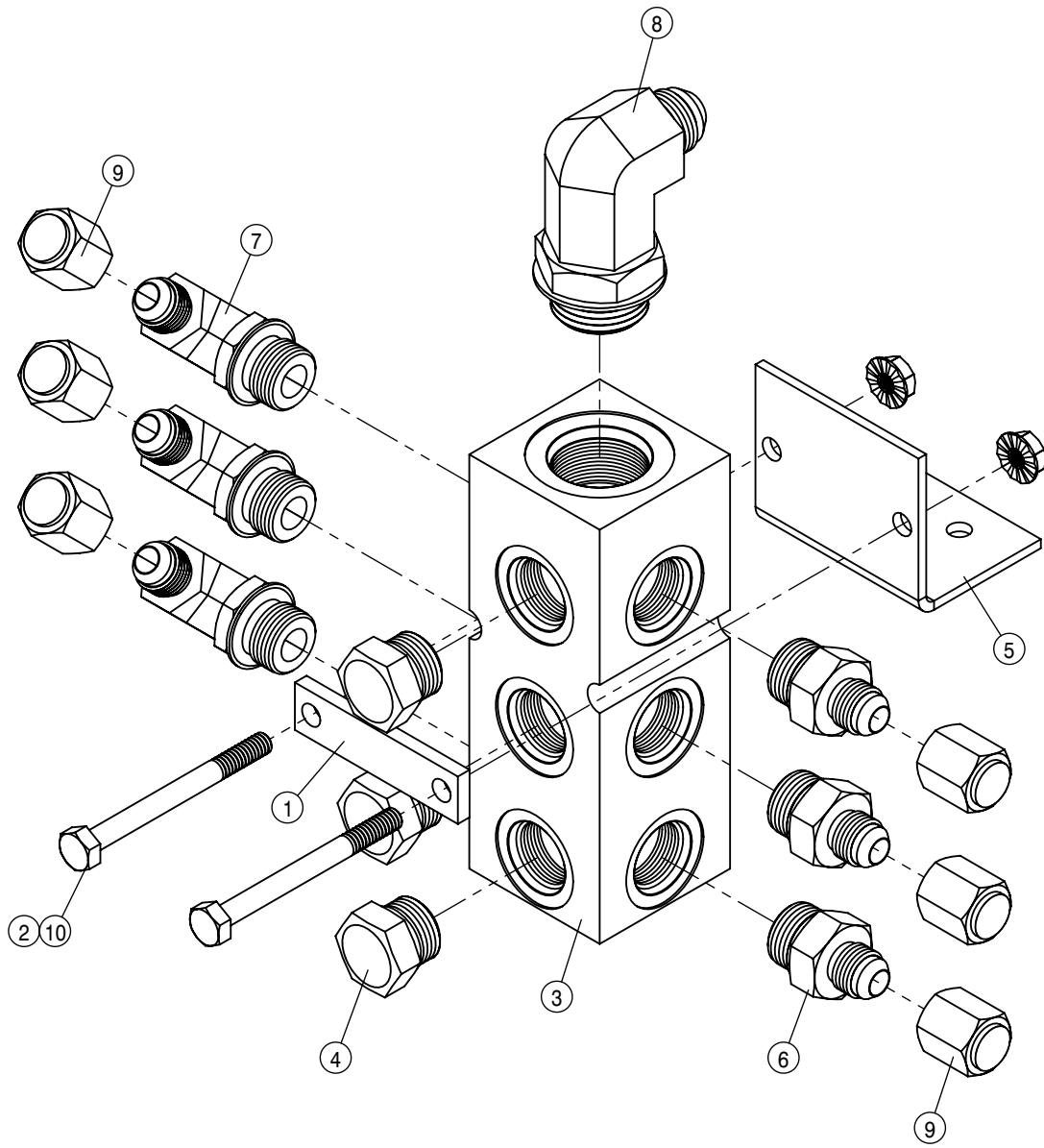

RETURN MANIFOLD ASSEMBLY			
DET	QTY	P/N	DESCRIPTION
1	1	438729	CUTTER RETURN MANIF MT KEEPER
2	2	470121	1/4 UNC SERR FLG LOCK NUT
3	1	606021	HYD RETURN MANIF,3/4FOR,9-PORT
4	3	611159	3/4MOR PLUG, HEX HEAD
5	1	615755	204 CASE DRAIN MANIFOLD MT
6	3	618109	9/16MJIC-3/4MOR ADPTR
7	3	618115	9/16MJIC-90-3/4MOR LBO
8	1	618474	3/4MJIC-90-1 1/16MOR LBO
9	6	618531	9/16FJIC CAP NUT
10	2	900009	1/4UNC X 2 3/4 HEX BOLT



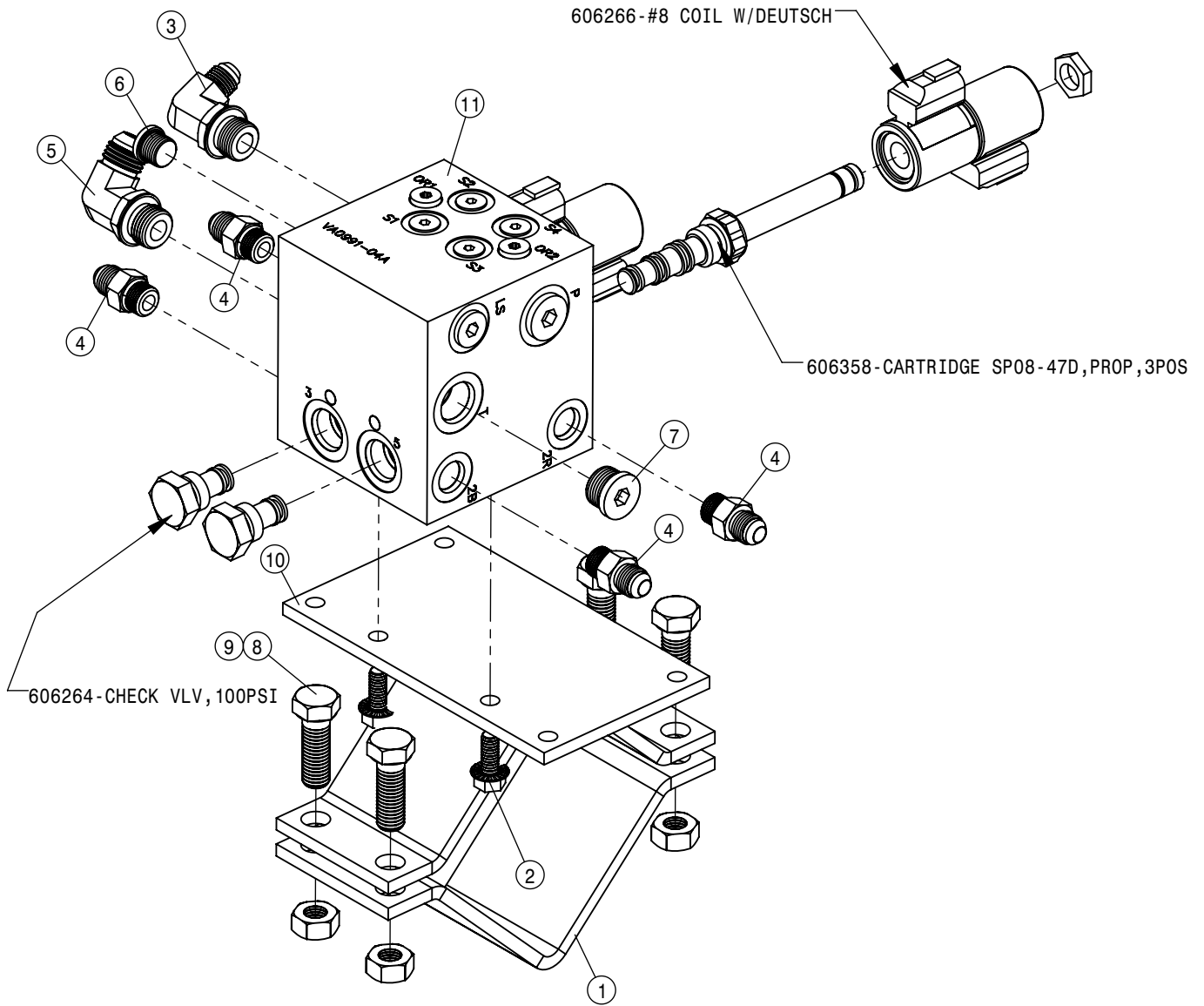

OUTRIGGER FOLD VALVE ASSEMBLY			
DET	QTY	P/N	DESCRIPTION
1	1	438324	75IN OUTRGR BRACE CLAMP (PAINT)
2	2	470233	5/16UNC X 3/4 SERR FLG HEX BOLT
3	1	618115	9/16MJIC-90-3/4MOR LBO
4	4	618126	9/16MJIC-9/16MOR ADPTR
5	1	618241	3/4MJIC-90-3/4MOR LBO
6	1	618754	9/16 MOR PLUG, HEX SOCKET
7	1	618755	3/4MOR PLUG, HEX SOCKET
8	4	900265	1/2UNC X 1 1/2 HEX BOLT
9	4	914008	1/2 UNC HEX STOVER NUT
10	1	438724	OUTRGR FOLD VALVE MT
11	1	606249	MANIFOLD,TRD ADJ PWRSYS

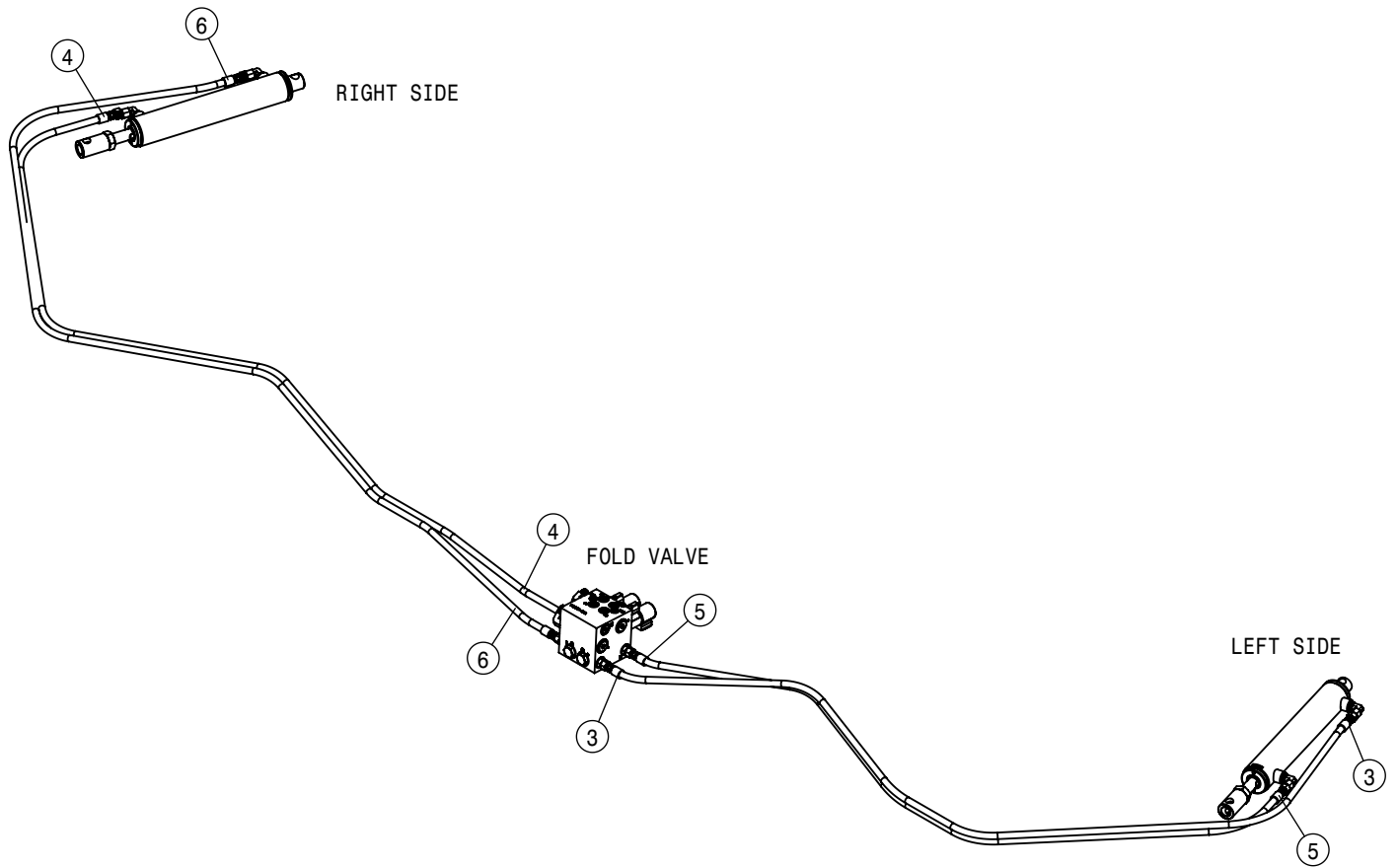

OUTRIGGER FOLD HOISING ASSEMBLY			
DET	QTY	P/N	DESCRIPTION
NS	1	293685	FOLD SWITCH POWER HARNESS
NS	1	294028	204 OUTRIGGER HARNESS
3	1	614077	04-482TC-06FJX-06FJX-88
4	1	614152	04-482TC-06FJX-06FJX-114
5	1	615727	04-482TC-06FJX-06FJX-75 H/A
6	1	616205	04-482TC-06FJX-06FJX-117 H/A

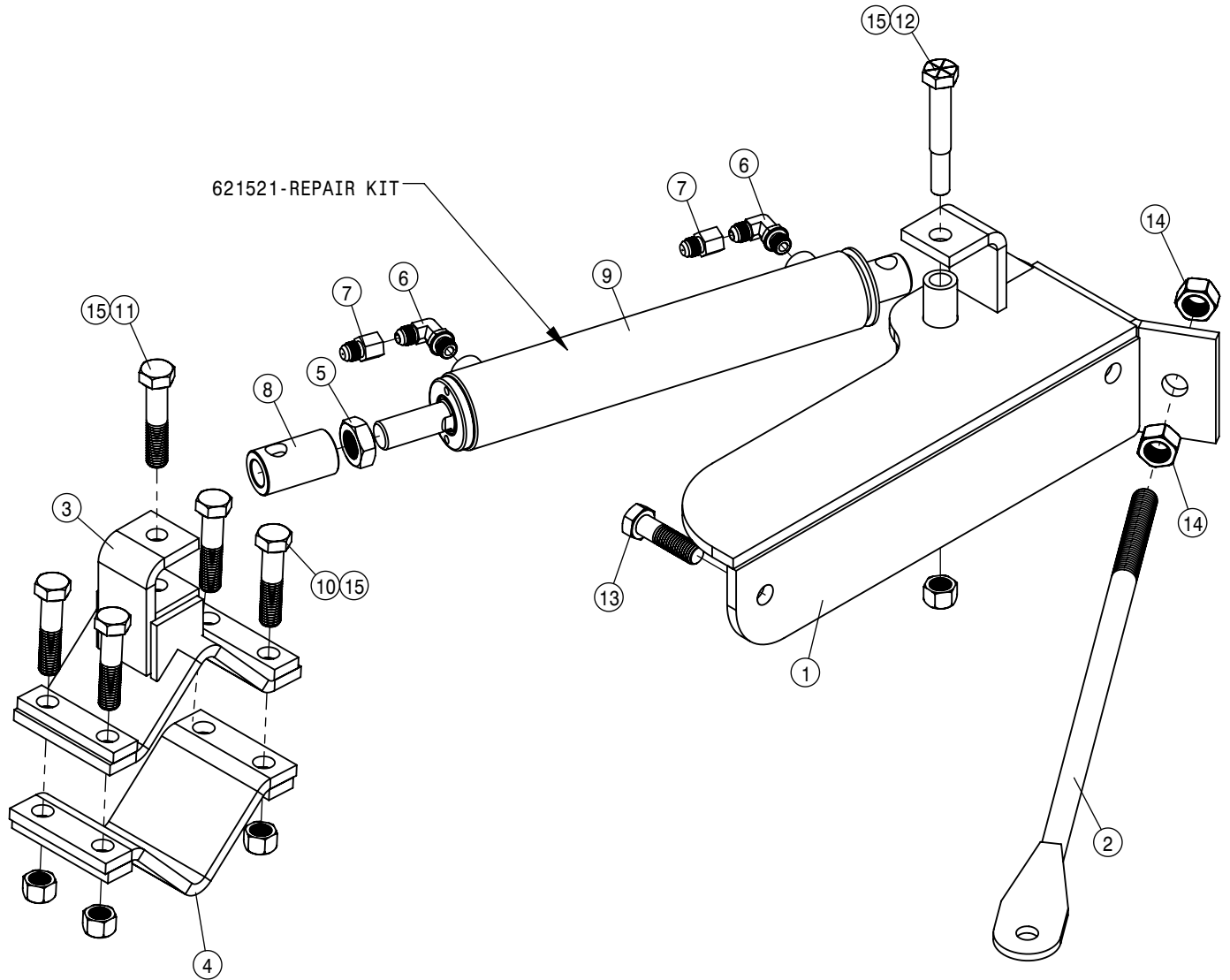

RIGHT OUTRIGGER FOLD ASSEMBLY			
DET	QTY	P/N	DESCRIPTION
1	1	438735	RH FOLD CYL MT WLD, 204/SP
2	1	438745	FOLD CYL MT SUPP ROD WLD204/SP
3	1	438772	OUTRGR CYL MT WLD, 204 08
4	1	438777	CYL MT KEEPER WLD, 204 08
5	1	472322	7/8-14 UNF HEX JAM NUT
6	2	618119	9/16MJIC-90-9/16MOR LBO
7	2	618731	9/16 - .025 ORIFICE ADPT
8	1	620653	FOLD CYL ADJ SLEEVE 97
9	1	621520	HYD CYL, 2.00 X 10.00 X 1.000
10	4	900337	5/8UNC X 2 3/4 HEX BOLT
11	1	900338	5/8 UNC X 3" HEX BOLT
12	1	900838	5/8UNF X 4 HHCS GR8 MC
13	1	900352	5/8UNC X 2 1/4 HEX BOLT
14	2	910012	3/4UNC HEX NUT
15	6	914010	5/8UNC HEX STOVER NUT

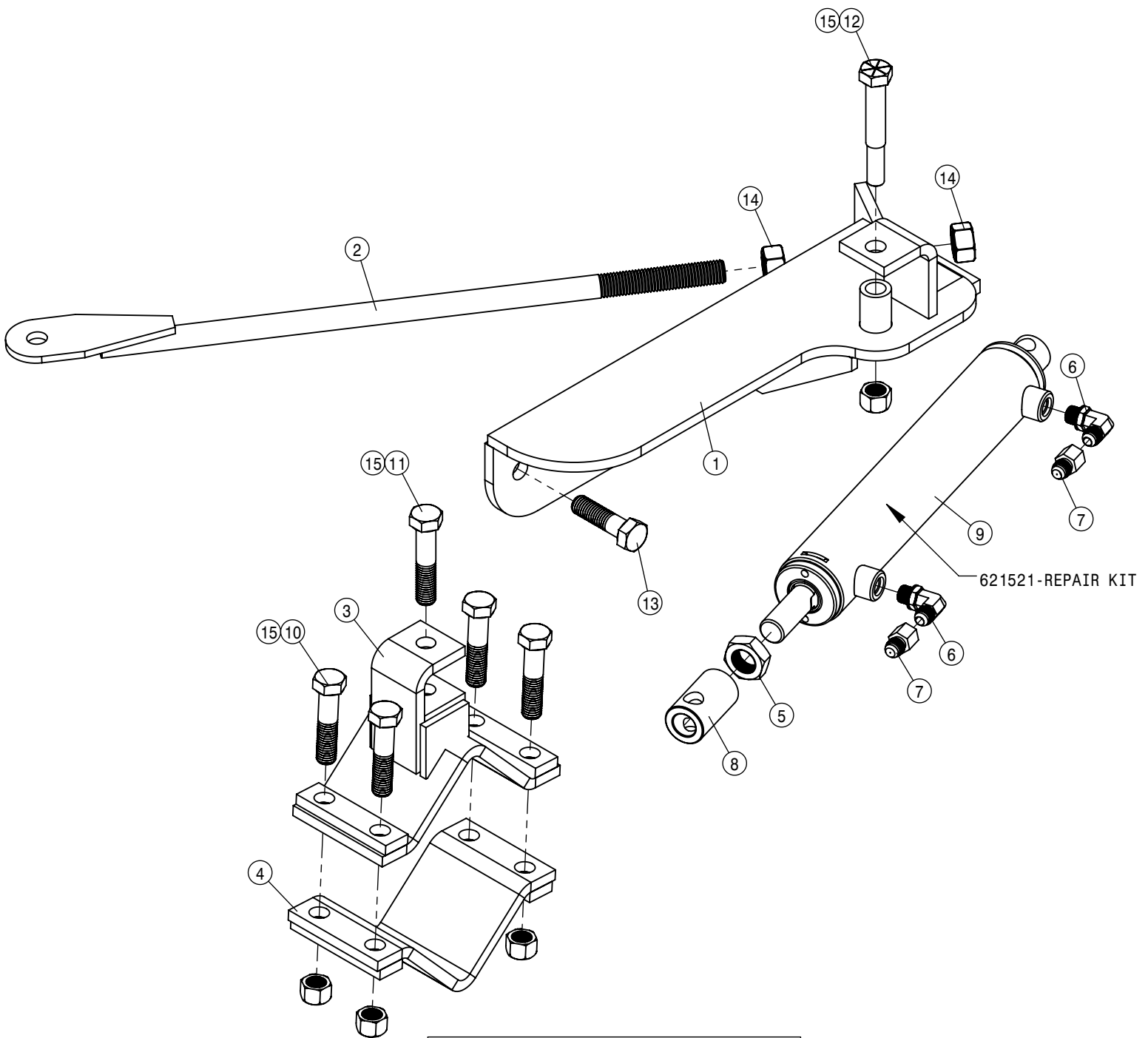

LEFT OUTRIGGER FOLD ASSEMBLY			
DET	QTY	P/N	DESCRIPTION
1	1	438736	LH FOLD CYL MT WLD, 204/SP
2	1	438745	FOLD CYL MT SUPP ROD WLD204/SP
3	1	438772	OUTRGR CYL MT WLD, 204 08
4	1	438777	CYL MT KEEPER WLD, 204 08
5	1	472322	7/8-14 UNF HEX JAM NUT
6	2	618119	9/16MJIC-90-9/16MOR LBO
7	2	618731	9/16 - .025 ORIFICE ADPT
8	1	620653	FOLD CYL ADJ SLEEVE 97
9	1	621520	HYD CYL, 2.00 X 10.00 X 1.000
10	4	900337	5/8UNF X 2 3/4 HEX BOLT
11	1	900338	5/8 UNC X 3" HEX BOLT
12	1	900838	5/8UNF X 4 HHCS GR8 MC
13	1	900352	5/8UNC X 2 1/4 HEX BOLT
14	2	910012	3/4UNC HEX NUT
15	6	914010	5/8UNC HEX STOVER NUT

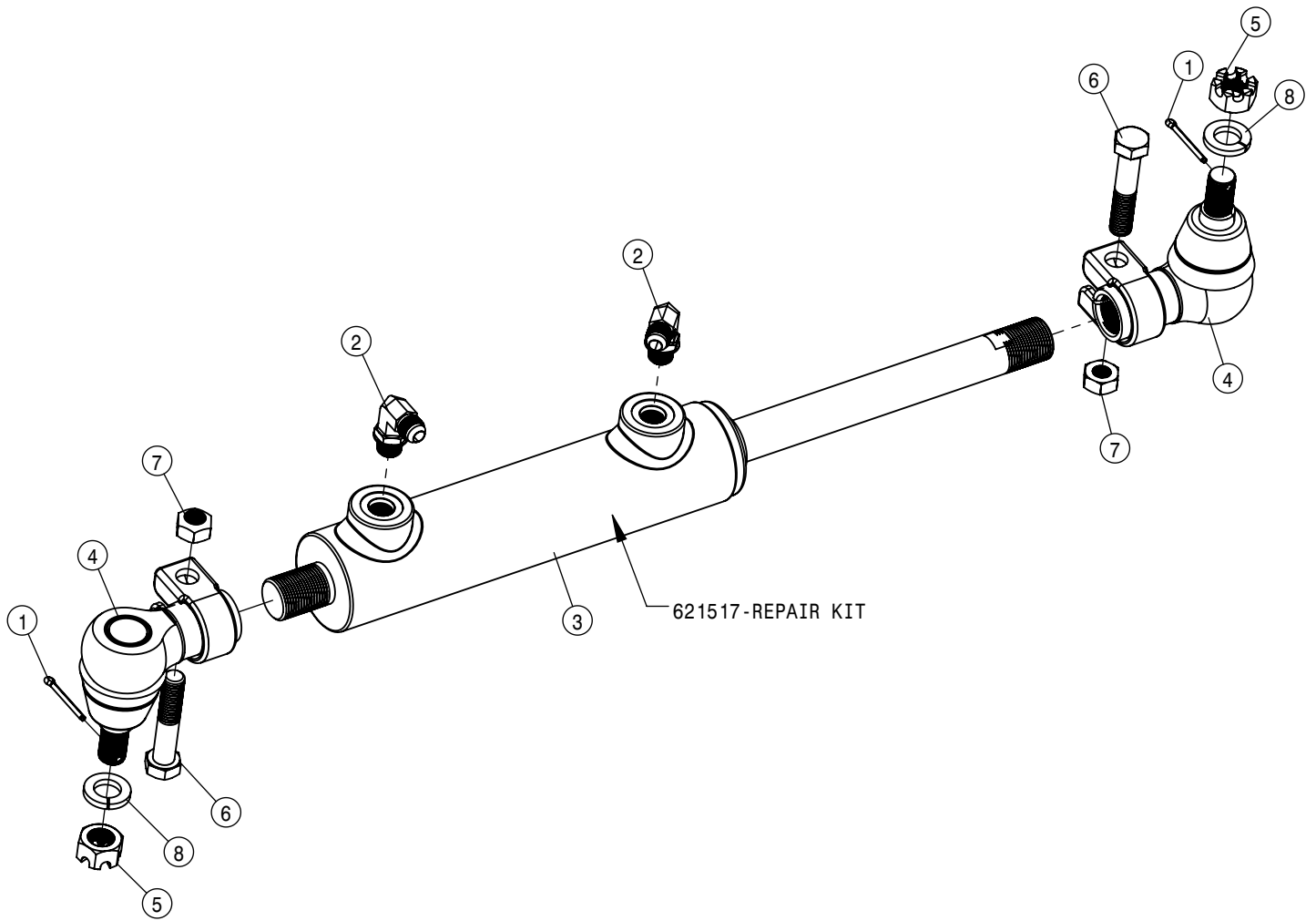

RIGHT STEERING CYLINDER ASSEMBLY			
DET	QTY	P/N	DESCRIPTION
1	2	390984	1/8 X 1 1/4 COTTER PIN
2	2	618119	9/16MJIC-90-9/16MOR LBO
3	1	621516	HYD CYL, 2.00 X 7.00 X 1.000
4	2	749312	RH STRG CYL SWIV ASSY
5	2	822040	5/8-18UNF SLOTTED HEX NUT
6	2	900268	1/2UNC X 2 1/2 HEX BOLT
7	2	914008	1/2 UNC HEX STOVER NUT
8	2	920505	5/8 LOCK WASHER

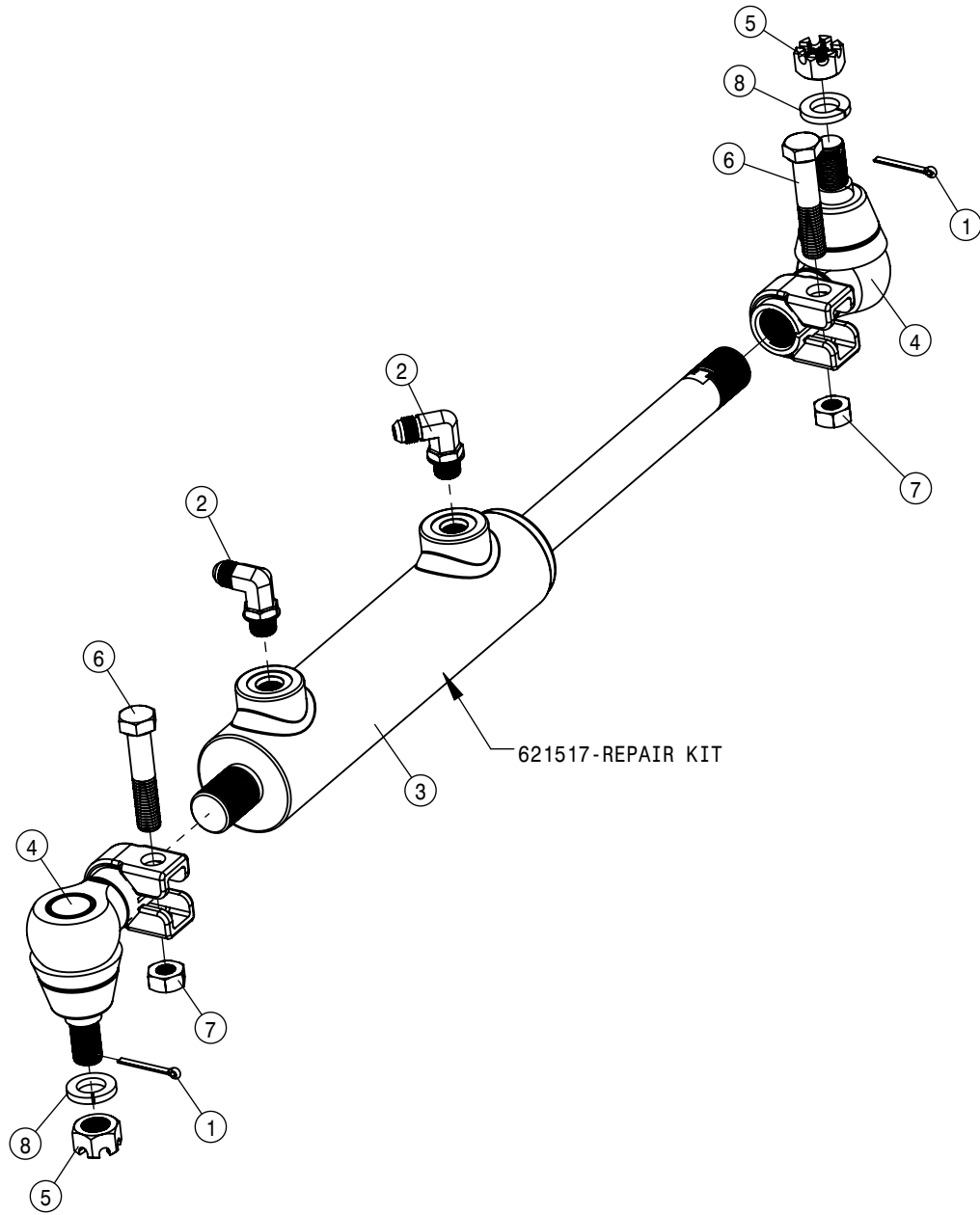

LEFT STEERING CYLINDER ASSEMBLY			
DET	QTY	P/N	DESCRIPTION
1	2	390984	1/8 X 1 1/4 COTTER PIN
2	2	618119	9/16MJIC-90-9/16MOR LBO
3	1	621516	HYD CYL, 2.00 X 7.00 X 1.000
4	2	749313	LH STRG CYL SWIV ASSY
5	2	822040	5/8-18UNF SLOTTED HEX NUT
6	2	900268	1/2UNC X 2 1/2 HEX BOLT
7	2	914008	1/2 UNC HEX STOVER NUT
8	2	920505	5/8 LOCK WASHER

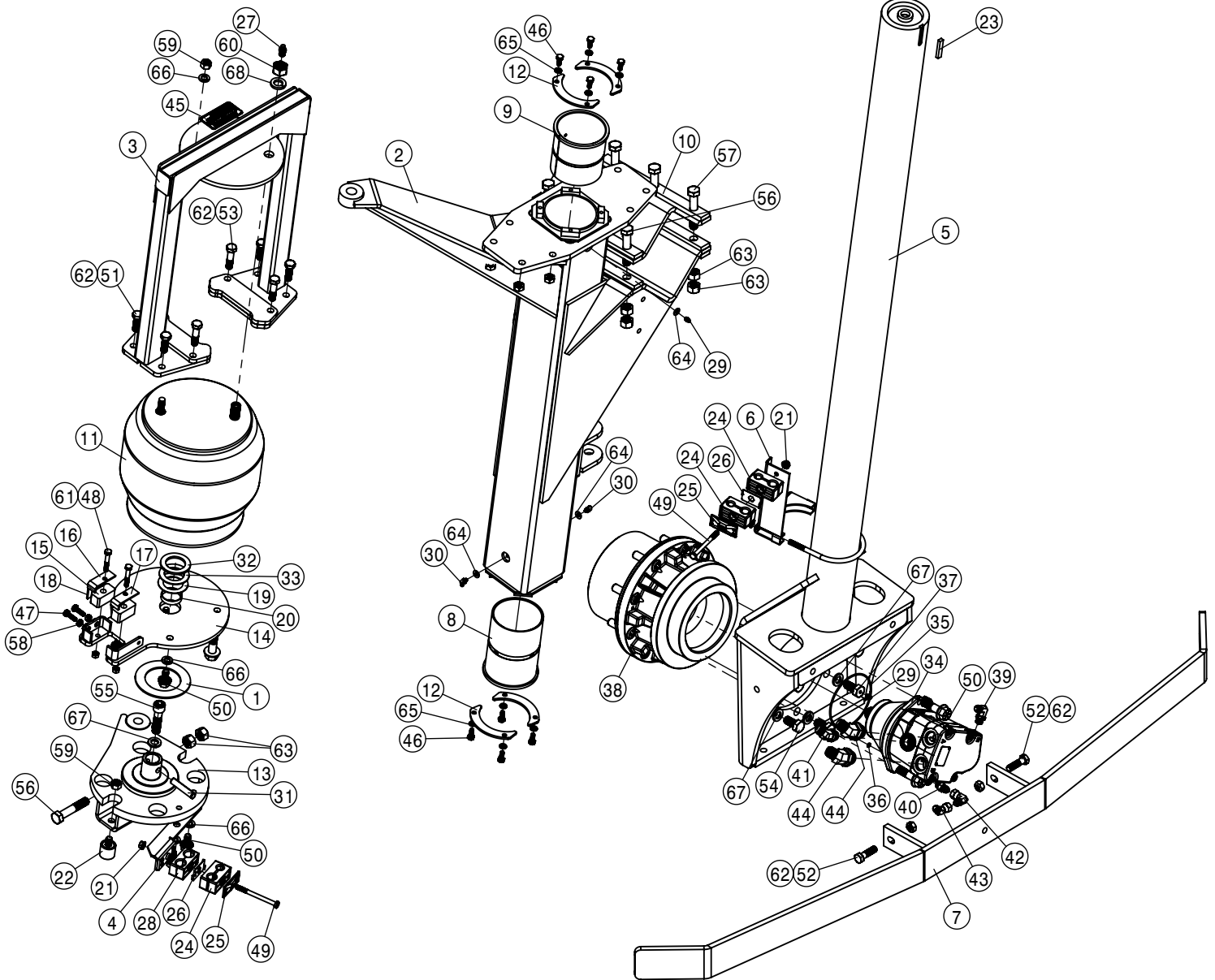

RIGHT FRONT LEG ASSEMBLY			
DET	QTY	P/N	DESCRIPTION
1	1	127505	THRUST BEARING, FIBERGUIDE
2	1	357857	RH FRT OUTER LEG WLD, 204SP 01
3	1	357864	AIR BAG ARCH WLD,RF/LR204SP 01
4	1	357870	RH UPR HYD HOSE BRKT WLD 204SP
5	1	357942	FRT INNER LEG WLD, 204SP 06
6	1	357946	RH FRT TUBE MT WLD, 204 07
7	1	357950	STALK GUIDE WLD, 204 07
8	1	358564	FRT LEG LWR NYL SLEEVE 280 89
9	1	358565	FRT LEG UPR NYL SLEEVE 280 89
10	1	358759	LEG MT V-PLT WLD, 284T 94
11	1	358831	AIRIDE SPRING
12	4	358927	LWR BRG KPR, LEG 98
13	1	358971	STEERING ARM WLD,RF/LR 2100 99
14	1	358980	AIR BAG MT WLD, RF/LR 2100 99
15	2	358990	NYLON GUIDE, 2100 LEG 99
16	1	358991	INNER KEEPER,NYL GUIDE,2100 99
17	1	358992	OUTER KEEPER,NYL GUIDE,2100 99
18	1	358993	.125 X 1.000 X 1.68 W/HOLEC/S
19	1	358994	LEG WASHER, NYLON 2100 99
20	1	358995	NYLON BEARING,LWR AB MT2100 99
21	2	470113	5/16UNC SERR FLG LOCK NUT
22	2	470259	URETHANE BUMPER, 1.25D X 1.25L
23	1	470265	.250 X .375 CFFL X 1.88 C/L

RIGHT FRONT LEG ASSEMBLY			
DET	QTY	P/N	DESCRIPTION
24	3	470270	TUBE CLAMP BODY, .530-.680
25	2	470276	CLAMP COVER PLATE,SNGL, 2.55LG
26	2	470281	STACK BOLT SAFETY LOCK PLATE
27	1	470338	AIR TANK VALVE, 1/4MNPT W/CAP
28	1	470343	TUBE CLAMP BODY, .875-.875
29	2	471005	GREASE ZERK, 1/4-28 X 1/2
30	2	471023	GREASE ZERK 1/4-28 X 45
31	1	473906	ROLL PIN, 1/2 X 2 1/2 COILED
32	1	483061	WASH: 7GA X 1.66 X 2.50
33	1	483063	WASH: 14GA X 1.66 X 2.50
34	1	606193	SAUER WHL MOTOR,KC-38CC
35	1	606197	O-RING, 4.73ID-.103CS-4.9430D
36	1	606198	O-RING .239ID .070CS .3790D
37	1	610013	ZERK BOLT, 5/8 X 1 1/4 TORQ HUB
38	1	611069	TORQ HUB 25.15:1 70CD
39	1	618119	9/16MJIC-90-9/16MOR LBO
40	1	618304	9/16MJIC-7/16MOR ADPTR
41	1	618315	3/4MJIC-45-3/4MOR LBO
42	1	618618	9/16MJIC-90-9/16FJIC SWIV LBO
43	1	618634	9/16MJIC-45-9/16FJIC SWIV LBO
44	2	618786	7/8MJIC-45-1 1/16MOR LBO
45	1	650364	DECAL, AIR BAG WARNING 100 PSI
46	8	900064	5/16UNC X 3/4" HEX BOLT

RIGHT FRONT LEG ASSEMBLY			
DET	QTY	P/N	DESCRIPTION
47	2	900065	5/16UNC X 1" HEX BOLT
48	2	900069	5/16UNC X 2" HEX BOLT
49	2	900075	5/16UNC X 3 3/4 HEX BOLT
50	8	900517	1/2UNC X 1 1/4 HHSFB GR5 MC
51	4	900265	1/2UNC X 1 1/2 HEX BOLT
52	2	900266	1/2UNC X 1 3/4 HEX BOLT
53	4	900267	1/2UNC X 2" HEX BOLT
54	5	900332	5/8UNC X 1 1/4 HEX BOLT
55	1	900390	5/8UNC X 2 1/2 SOCKET CAP SCR
56	4	900836	5/8UNF X 3 1/4 HEX BOLT GR8
57	3	900837	5/8UNF X 3 1/2 HEX BOLT GR8
58	2	910002	5/16UNC HEX NUT
59	3	910008	1/2UNC HEX NUT
60	1	910013	3/4UNF HEX NUT
61	2	914002	5/16UNC HEX STOVER NUT
62	10	914008	1/2 UNC HEX STOVER NUT
63	14	914811	5/8UNF HEX NUT GR8
64	3	920000	1/4 SAE FLAT WASHER
65	8	920501	5/16 LOCK WASHER
66	7	920504	1/2 LOCK WASHER
67	7	920505	5/8 LOCK WASHER
68	1	920506	3/4 LOCK WASHER

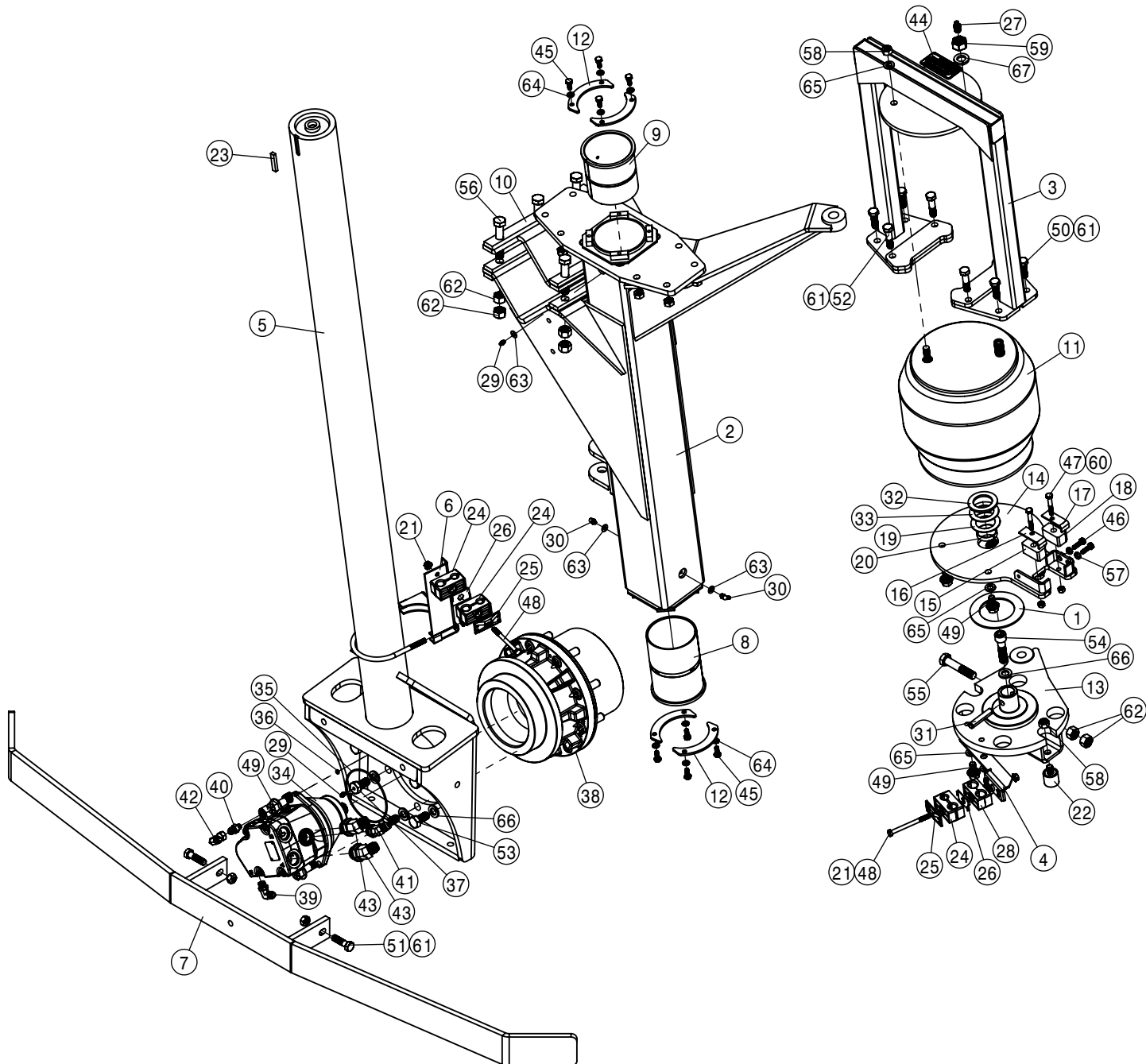

LEFT FRONT LEG ASSEMBLY			
DET	QTY	P/N	DESCRIPTION
1	1	127505	THRUST BEARING, FIBERGUIDE
2	1	357858	LH FRT OUTER LEG WLD. 204SP 01
3	1	357865	AIR BAG ARCH WLD,LF/RR204SP 01
4	1	357871	LH UPR HYD HOSE BRKT WLD 204SP
5	1	357942	FRT INNER LEG WLD, 204SP 06
6	1	357947	LH FRT TUBE MT WLD, 204 07
7	1	357950	STALK GUIDE WLD, 204 07
8	1	358564	FRT LEG LWR NYL SLEEVE 280 89
9	1	358565	FRT LEG UPR NYL SLEEVE 280 89
10	1	358759	LEG MT V-PLT WLD, 284T 94
11	1	358831	AIRIDE SPRING
12	4	358927	LWR BRG KPR, LEG 98
13	1	358972	STEERING ARM WLD,LF/RR 2100 99
14	1	358981	AIR BAG MT WLD, LF/RR 2100 99
15	2	358990	NYLON GUIDE, 2100 LEG 99
16	1	358991	INNER KEEPER,NYL GUIDE,2100 99
17	1	358992	OUTER KEEPER,NYL GUIDE,2100 99
18	1	358993	.125 X 1.000 X 1.68 W/HOLEC/S
19	1	358994	LEG WASHER, NYLON 2100 99
20	1	358995	NYLON BEARING,LWR AB MT2100 99
21	2	470113	5/16UNC SERR FLG LOCK NUT
22	2	470259	URETHANE BUMPER, 1.25D X 1.25L
23	1	470265	.250 X .375 CFFL X 1.88 C/L

LEFT FRONT LEG ASSEMBLY			
DET	QTY	P/N	DESCRIPTION
24	3	470270	TUBE CLAMP BODY, .530-.680
25	2	470276	CLAMP COVER PLATE,SNGL, 2.55LG
26	2	470281	STACK BOLT SAFETY LOCK PLATE
27	1	470338	AIR TANK VALVE, 1/4MNPT W/CAP
28	1	470343	TUBE CLAMP BODY, .875-.875
29	2	471005	GREASE ZERK, 1/4-28 X 1/2
30	2	471023	GREASE ZERK 1/4-28 X 45
31	1	473906	ROLL PIN, 1/2 X 2 1/2 COILED
32	1	483061	WASH: 7GA X 1.66 X 2.50
33	1	483063	WASH: 14GA X 1.66 X 2.50
34	1	606193	SAUER WHL MOTOR,KC-38CC
35	1	606197	O-RING, 4.73ID-.103CS-4.9430D
36	1	606198	O-RING .239ID .070CS .3790D
37	1	610013	ZERK BOLT, 5/8 X 1 1/4 TORQ HUB
38	1	611069	TORQ HUB 25.15:1 70CD
39	1	618119	9/16MJIC-90-9/16MOR LBO
40	1	618304	9/16MJIC-7/16MOR ADPTR
41	1	618315	3/4MJIC-45-3/4MOR LBO
42	1	618618	9/16MJIC-90-9/16JIC SWIV LBO
43	2	618786	7/8MJIC-45-1 1/16MOR LBO
44	1	650364	DECAL, AIR BAG WARNING 100 PSI
45	8	900064	5/16UNC X 3/4" HEX BOLT
46	2	900065	5/16UNC X 1" HEX BOLT

LEFT FRONT LEG ASSEMBLY			
DET	QTY	P/N	DESCRIPTION
47	2	900069	5/16UNC X 2" HEX BOLT
48	2	900075	5/16UNC X 3 3/4 HEX BOLT
49	8	900517	1/2UNC X 1 1/4 HHSFB GR5 MC
50	4	900265	1/2UNC X 1 1/2 HEX BOLT
51	2	900266	1/2UNC X 1 3/4 HEX BOLT
52	4	900267	1/2UNC X 2" HEX BOLT
53	5	900332	5/8UNC X 1 1/4 HEX BOLT
54	1	900390	5/8UNC X 2 1/2 SOCKET CAP SCR
55	4	900836	5/8UNF X 3 1/4 HEX BOLT GR8
56	3	900837	5/8UNF X 3 1/2 HEX BOLT GR8
57	2	910002	5/16UNC HEX NUT
58	3	910008	1/2UNC HEX NUT
59	1	910013	3/4UNF HEX NUT
60	2	914002	5/16UNC HEX STOVER NUT
61	10	914008	1/2 UNC HEX STOVER NUT
62	14	914811	5/8UNF HEX NUT GR8
63	3	920000	1/4 SAE FLAT WASHER
64	8	920501	5/16 LOCK WASHER
65	7	920504	1/2 LOCK WASHER
66	7	920505	5/8 LOCK WASHER
67	1	920506	3/4 LOCK WASHER



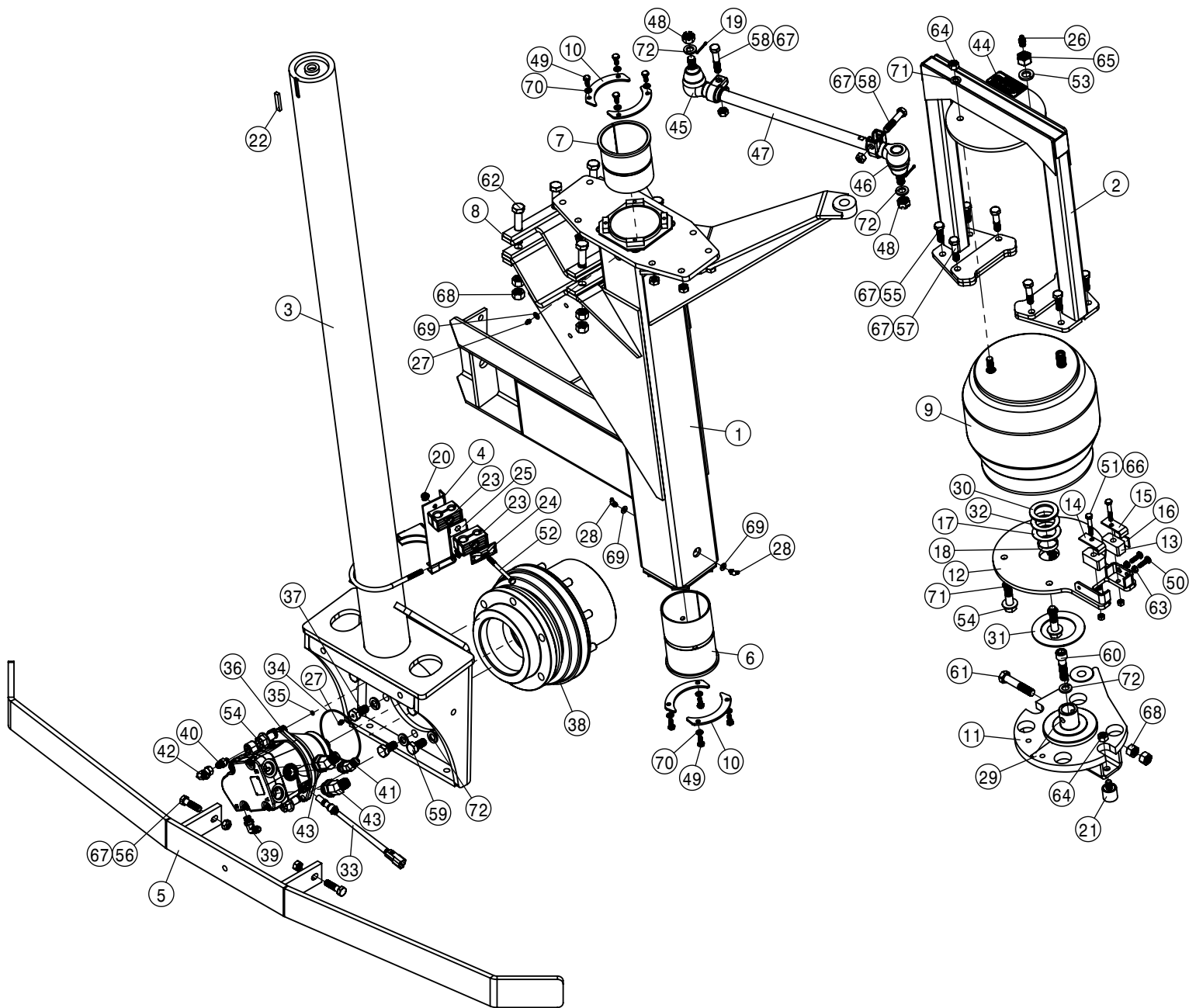

RIGHT REAR LEG ASSEMBLY			
DET	QTY	P/N	DESCRIPTION
1	1	357859	RH REAR OUTER LEG WLD, 204SP 01
2	1	357865	AIR BAG ARCH WLD,LF/RR204SP 01
3	1	357942	FRT INNER LEG WLD, 204SP 06
4	1	357947	LH FRT TUBE MT WLD, 204 07
5	1	357950	STALK GUIDE WLD, 204 07
6	1	358564	FRT LEG LWR NYL SLEEVE 280 89
7	1	358565	FRT LEG UPN NYL SLEEVE 280 89
8	1	358759	LEG MT V-PLT WLD, 284T 94
9	1	358831	AIRIDE SPRING
10	4	358927	LWR BRG KPR, LEG 98
11	1	358972	STEERING ARM WLD,LF/RR 2100 99
12	1	358981	AIR BAG MT WLD, LF/RR 2100 99
13	2	358990	NYLON GUIDE, 2100 LEG 99
14	1	358991	INNER KEEPER,NYL GUIDE,2100 99
15	1	358992	OUTER KEEPER,NYL GUIDE,2100 99
16	1	358993	.125 X 1.000 X 1.68 W/HOLEC/S
17	1	358994	LEG WASHER, NYLON 2100 99
18	1	358995	NYLON BEARING,LWR AB MT2100 99
19	2	390984	1/8 X 1 1/4 COTTER PIN
20	1	470113	5/16UNC SERR FLG LOCK NUT
21	2	470259	URETHANE BUMPER, 1.25D X 1.25L
22	1	470265	.250 X .375 OFFL X 1.88 C/L
23	2	470270	TUBE CLAMP BODY, .530-.680
24	1	470276	CLAMP COVER PLATE,SNGL, 2.55LG

RIGHT REAR LEG ASSEMBLY			
DET	QTY	P/N	DESCRIPTION
25	1	470281	STACK BOLT SAFETY LOCK PLATE
26	1	470338	AIR TANK VALVE, 1/4MNPT W/CAP
27	2	471005	GREASE ZERK, 1/4-28 X 1/2
28	2	471023	GREASE ZERK 1/4-28 X 45
29	1	473906	ROLL PIN, 1/2 X 2 1/2 COILED
30	1	483061	WASH: 7GA X 1.66 X 2.50
31	1	483062	3.031 ID X 4.62 OD X .125T WASH
32	1	483063	WASH: 14GA X 1.66 X 2.50
33	1	606192	SPEED SENSOR,WHEEL MTR
34	1	606197	O-RING, 4.73ID-.103CS-4.9430D
35	1	606198	O-RING .239ID .070CS .3790D
36	1	606203	SAUER WHL MOTOR, KC-38CC
37	1	610013	ZERK BOLT, 5/8 X 1 1/4 TORQ HUB
38	1	611068	TORQ HUB 17.94:1 70CD
39	1	618119	9/16MJIC-90-9/16MOR LBO
40	1	618304	9/16MJIC-7/16MOR ADPTR
41	1	618315	3/4MJIC-45-3/4MOR LBO
42	1	618618	9/16MJIC-90-9/16FJIC SWIV LBO
43	2	618786	7/8MJIC-45-1 1/16MOR LBO
44	1	650364	DECAL, AIR BAG WARNING 100 PSI
45	1	749313	LH STRG CYL SWIV ASSY
46	1	749323	TIE ROD END, 1.00-16 LH THD
47	1	749324	TIE ROD, REAR LEG, SP/XP/2100 03
48	2	822040	5/8-18UNF SLOTTED HEX NUT

RIGHT REAR LEG ASSEMBLY			
DET	QTY	P/N	DESCRIPTION
49	8	900064	5/16UNC X 3/4" HEX BOLT
50	2	900065	5/16UNC X 1" HEX BOLT
51	2	900069	5/16UNC X 2" HEX BOLT
52	1	900075	5/16UNC X 3 3/4 HEX BOLT
53	1	920506	3/4 LOCK WASHER
54	7	900517	1/2UNC X 1 1/4 HHSFB GR5 MC
55	4	900265	1/2UNC X 1 1/2 HEX BOLT
56	2	900266	1/2UNC X 1 3/4 HEX BOLT
57	4	900267	1/2UNC X 2" HEX BOLT
58	2	900268	1/2UNC X 2 1/2 HEX BOLT
59	5	900332	5/8UNC X 1 1/4 HEX BOLT
60	1	900390	5/8UNC X 2 1/2 SOCKET CAP SCR
61	4	900836	5/8UNF X 3 1/4 HEX BOLT GR8
62	3	900837	5/8UNF X 3 1/2 HEX BOLT GR8
63	2	910002	5/16UNC HEX NUT
64	3	910008	1/2UNC HEX NUT
65	1	910013	3/4UNF HEX NUT
66	2	914002	5/16UNC HEX STOVER NUT
67	12	914008	1/2 UNC HEX STOVER NUT
68	14	914811	5/8UNF HEX NUT GR8
69	3	920000	1/4 SAE FLAT WASHER
70	8	920501	5/16 LOCK WASHER
71	5	920504	1/2 LOCK WASHER
72	9	920505	5/8 LOCK WASHER

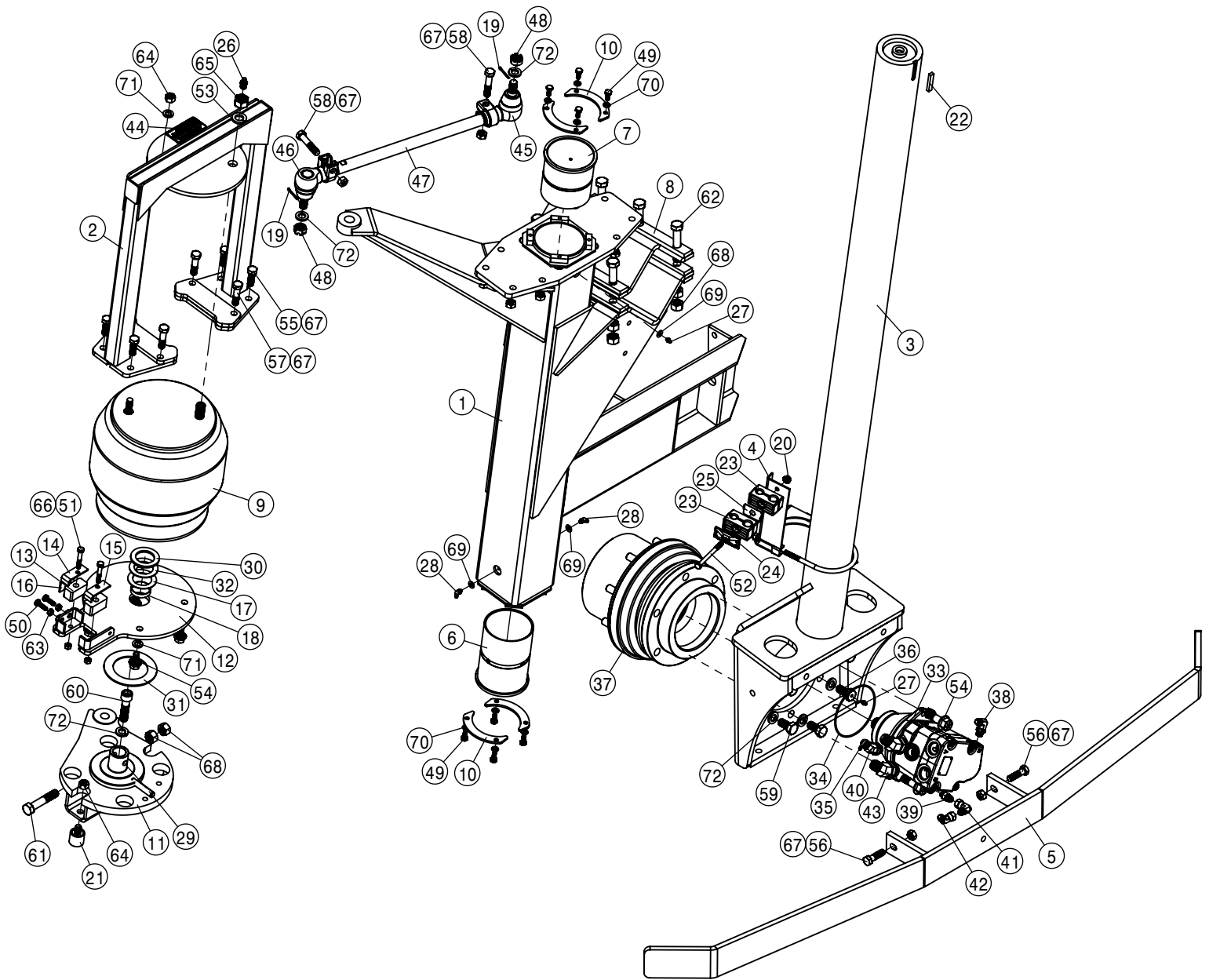

LEFT REAR LEG ASSEMBLY

DET	QTY	P/N	DESCRIPTION
1	1	357860	LH REAR OUTER LEG WLD,204SP 01
2	1	357864	AIR BAG ARCH WLD,RF/LR204SP 01
3	1	357942	FRT INNER LEG WLD, 204SP 06
4	1	357946	RH FRT TUBE MT WLD, 204 07
5	1	357950	STALK GUIDE WLD, 204 07
6	1	358564	FRT LEG LWR NYL SLEEVE 280 89
7	1	358565	FRT LEG UPR NYL SLEEVE 280 89
8	1	358759	LEG MT V-PLT WLD, 284T 94
9	1	358831	AIRIDE SPRING
10	4	358927	LWR BRG KPR, LEG 98
11	1	358971	STEERING ARM WLD,RF/LR 2100 99
12	1	358980	AIR BAG MT WLD, RF/LR 2100 99
13	2	358990	NYLON GUIDE, 2100 LEG 99
14	1	358991	INNER KEEPER,NYL GUIDE,2100 99
15	1	358992	OUTER KEEPER,NYL GUIDE,2100 99
16	1	358993	.125 X 1.000 X 1.68 W/HOLEC/S
17	1	358994	LEG WASHER, NYLON 2100 99
18	1	358995	NYLON BEARING,LWR AB MT2100 99
19	2	390984	1/8 X 1 1/4 COTTER PIN
20	1	470113	5/16UNC SERR FLG LOCK NUT
21	2	470259	URETHANE BUMPER, 1.25D X 1.25L
22	1	470265	.250 X .375 CFFL X 1.88 C/L
23	2	470270	TUBE CLAMP BODY, .530-.680
24	1	470276	CLAMP COVER PLATE,SNGL, 2.55LG
25	1	470281	STACK BOLT SAFETY LOCK PLATE

LEFT REAR LEG ASSEMBLY

DET	QTY	P/N	DESCRIPTION
26	1	470338	AIR TANK VALVE, 1/4MNPT W/CAP
27	2	471005	GREASE ZERK, 1/4-28 X 1/2
28	2	471023	GREASE ZERK 1/4-28 X 45
29	1	473906	ROLL PIN, 1/2 X 2 1/2 COILED
30	1	483061	WASH: 7GA X 1.66 X 2.50
31	1	483062	3.031 ID X 4.62 OD X .125T WASH
32	1	483063	WASH: 14GA X 1.66 X 2.50
33	1	606193	SAUER WHL MOTOR,KC-38CC
34	1	606197	O-RING, 4.73ID-.103CS-4.9430D
35	1	606198	O-RING .239ID .070CS .3790D
36	1	610013	ZERK BOLT, 5/8 X 1 1/4 TORQ HUB
37	1	611068	TORQ HUB 17.94:1 70CD
38	1	618119	9/16MJIC-90-9/16MOR LBO
39	1	618304	9/16MJIC-7/16MOR ADPTR
40	1	618315	3/4MJIC-45-3/4MOR LBO
41	1	618618	9/16MJIC-90-9/16FJIC SWIV LBO
42	1	618634	9/16MJIC-45-9/16FJIC SWIV LBO
43	2	618786	7/8MJIC-45-1 1/16MOR LBO
44	1	650364	DECAL, AIR BAG WARNING 100 PSI
45	1	749312	RH STRG CYL SWIV ASSY
46	1	749323	TIE ROD END, 1.00-16 LH THD
47	1	749324	TIE ROD, REAR LEG, SP/XP/2100 03
48	2	822040	5/8-18UNF SLOTTED HEX NUT
49	8	900064	5/16UNC X 3/4" HEX BOLT
50	2	900065	5/16UNC X 1" HEX BOLT

LEFT REAR LEG ASSEMBLY

DET	QTY	P/N	DESCRIPTION
51	2	900069	5/16UNC X 2" HEX BOLT
52	1	900075	5/16UNC X 3 3/4 HEX BOLT
53	1	920506	3/4 LOCK WASHER
54	7	900517	1/2UNC X 1 1/4 HHSFB GR5 MC
55	4	900265	1/2UNC X 1 1/2 HEX BOLT
56	2	900266	1/2UNC X 1 3/4 HEX BOLT
57	4	900267	1/2UNC X 2" HEX BOLT
58	2	900268	1/2UNC X 2 1/2 HEX BOLT
59	5	900332	5/8UNC X 1 1/4 HEX BOLT
60	1	900390	5/8UNC X 2 1/2 SOCKET CAP SCR
61	4	900836	5/8UNF X 3 1/4 HEX BOLT GR8
62	3	900837	5/8UNF X 3 1/2 HEX BOLT GR8
63	2	910002	5/16UNC HEX NUT
64	3	910008	1/2UNC HEX NUT
65	1	910013	3/4UNF HEX NUT
66	2	914002	5/16UNC HEX STOVER NUT
67	12	914008	1/2 UNC HEX STOVER NUT
68	14	914811	5/8UNF HEX NUT GR8
69	3	920000	1/4 SAE FLAT WASHER
70	8	920501	5/16 LOCK WASHER
71	5	920504	1/2 LOCK WASHER
72	9	920505	5/8 LOCK WASHER

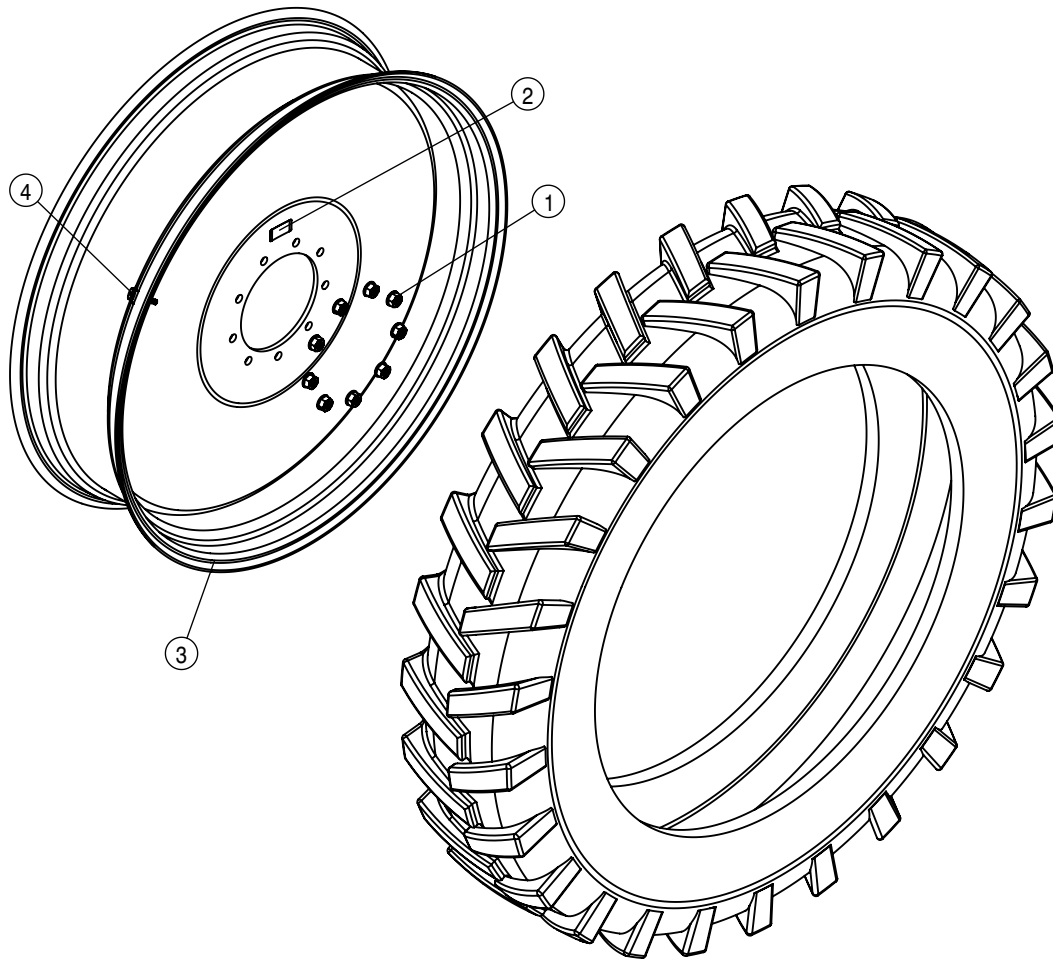

11.2-38 TIRE

TIRE AND RIM ASSEMBLY			
DET	QTY	P/N	DESCRIPTION
1	9	470140	5/8UNF SMTH FLG HEX NUT GR8
2	1	650985	DECAL, WHL BOLT TORQ 203854C
3	1	821050	RIM WLD, W10 X 38, W1M1 204
4	1	821252	VALVE STEM, TR-618A, STAINLESS

LEFT FUEL TANK

RIGHT FUEL TANK

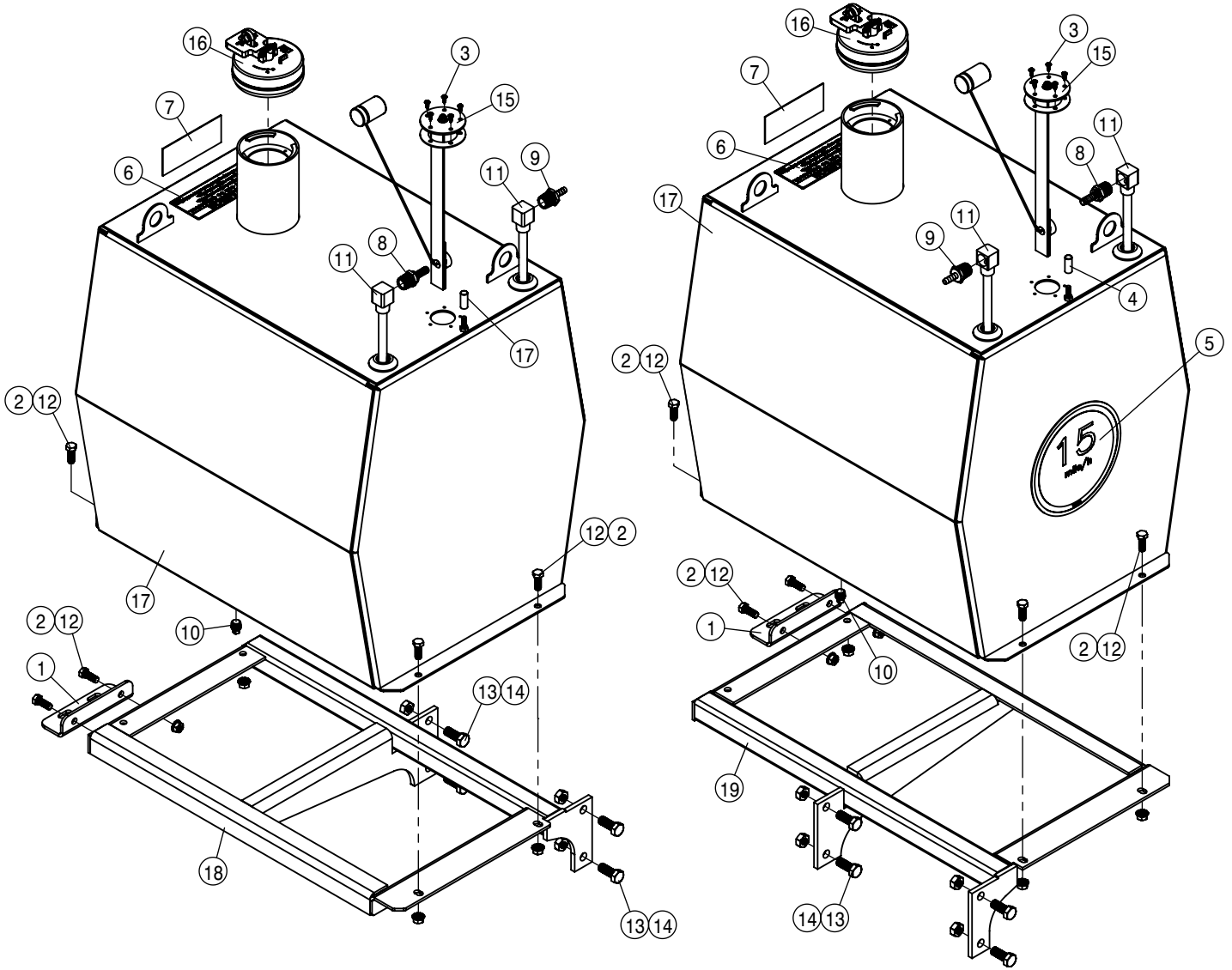

FUEL TANK ASSEMBLY			
DET	QTY	P/N	DESCRIPTION
1	2	343730	REAR PLATFORM SUPPORT ANGLE
2	12	470087	3/8UNC HEX SERR FLANGE NUT
3	10	473902	#8 X 1/2 PHIL PAN HD MTL SCR
4	2	629736	CAPPLUGS CAP, .312 X 1.00 VINYL
5	1	650130	DECAL, 15 MILE/H 204SP
6	2	650849	DECAL, CAUTION, ENG FUEL
7	2	650954	DECAL, DIESEL
8	2	711080	1/2MNPT -3/8 BARB, BRS
9	2	711081	1/2MNPT -5/16 BARB, BRS
10	2	760889	1/4 PIPE PLUG SS
11	4	760895	FUEL SUCTION DROP TUBE, 204
12	12	900129	3/8UNC X 1" HEX BOLT
13	8	900264	1/2UNC X 1 1/4 HEX BOLT
14	8	914008	1/2 UNC HEX STOVER NUT
15	2	291428	FUEL SENDER 19 IN
16	2	760469	FUEL TANK CAP, 3.50" VENTED
17	2	760883	FUEL TANK WLD SS
18	1	760891	LH FUEL TANK SS MT WLD
19	1	760892	RH FUEL TANK SS MT WLD

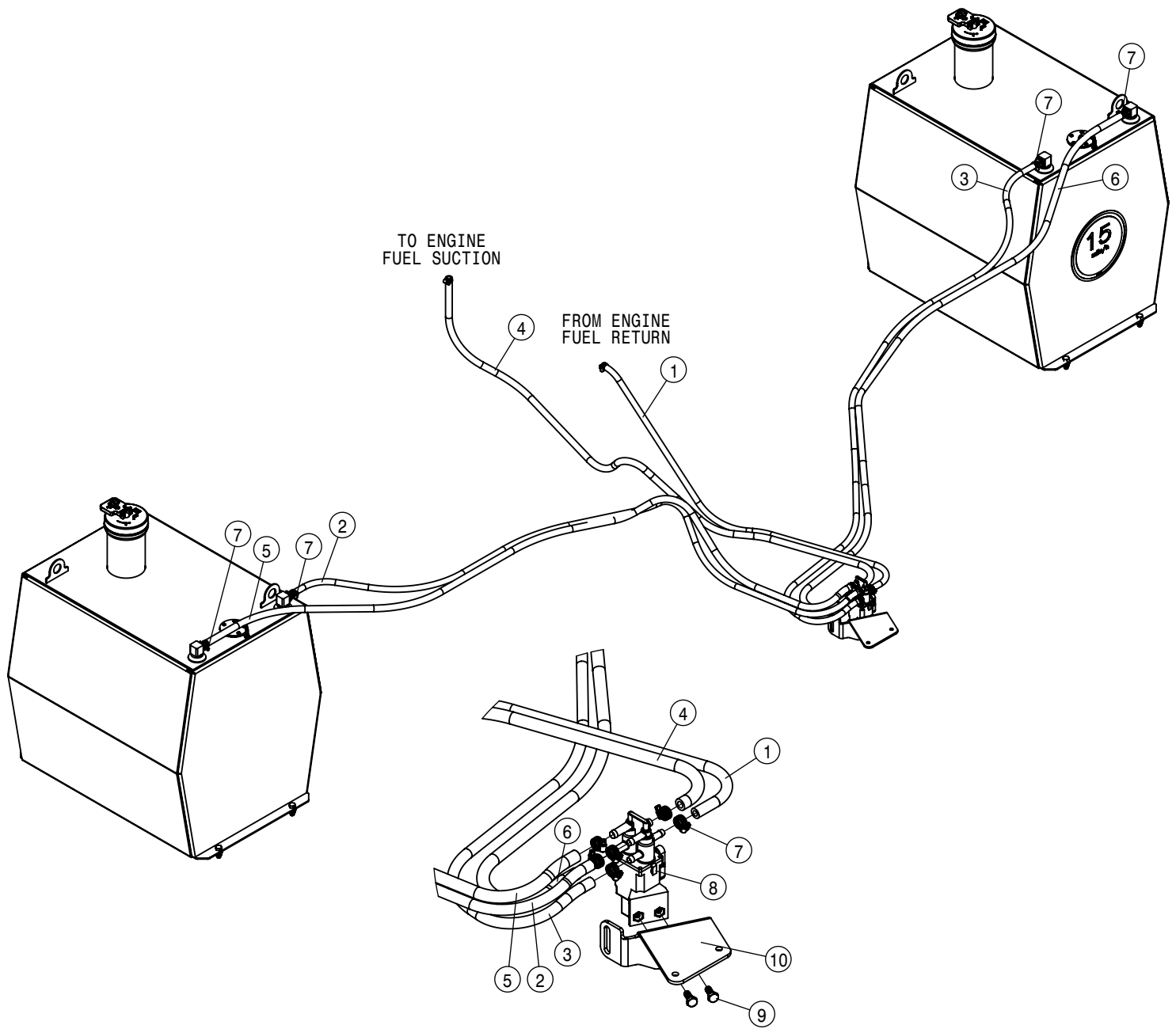

FUEL LINES AND SELECTOR VALVE ASSEMBLY			
DET	QTY	P/N	DESCRIPTION
1	1	195900-042	HOSE 5/16 FUEL LN 1-FBR 30R1
2	1	195900-070	HOSE 5/16 FUEL LN 1-FBR 30R1
3	1	195900-082	HOSE 5/16 FUEL LN 1-FBR 30R1
4	1	195901-065	HOSE 3/8 FUEL LN 1-FBR 30R1
5	1	195901-079	HOSE 3/8 FUEL LN 1-FBR 30R1
6	1	195901-089	HOSE 3/8 FUEL LN 1-FBR 30R1
7	12	520120	HOSE CLAMP NO 4 STAINLESS
8	1	610529	FUEL SELECTOR VALVE W/RETURN
9	2	900064	5/16UNC X 3/4" HEX BOLT
10	1	362462	FUEL SELECTOR BRKT 204 T3

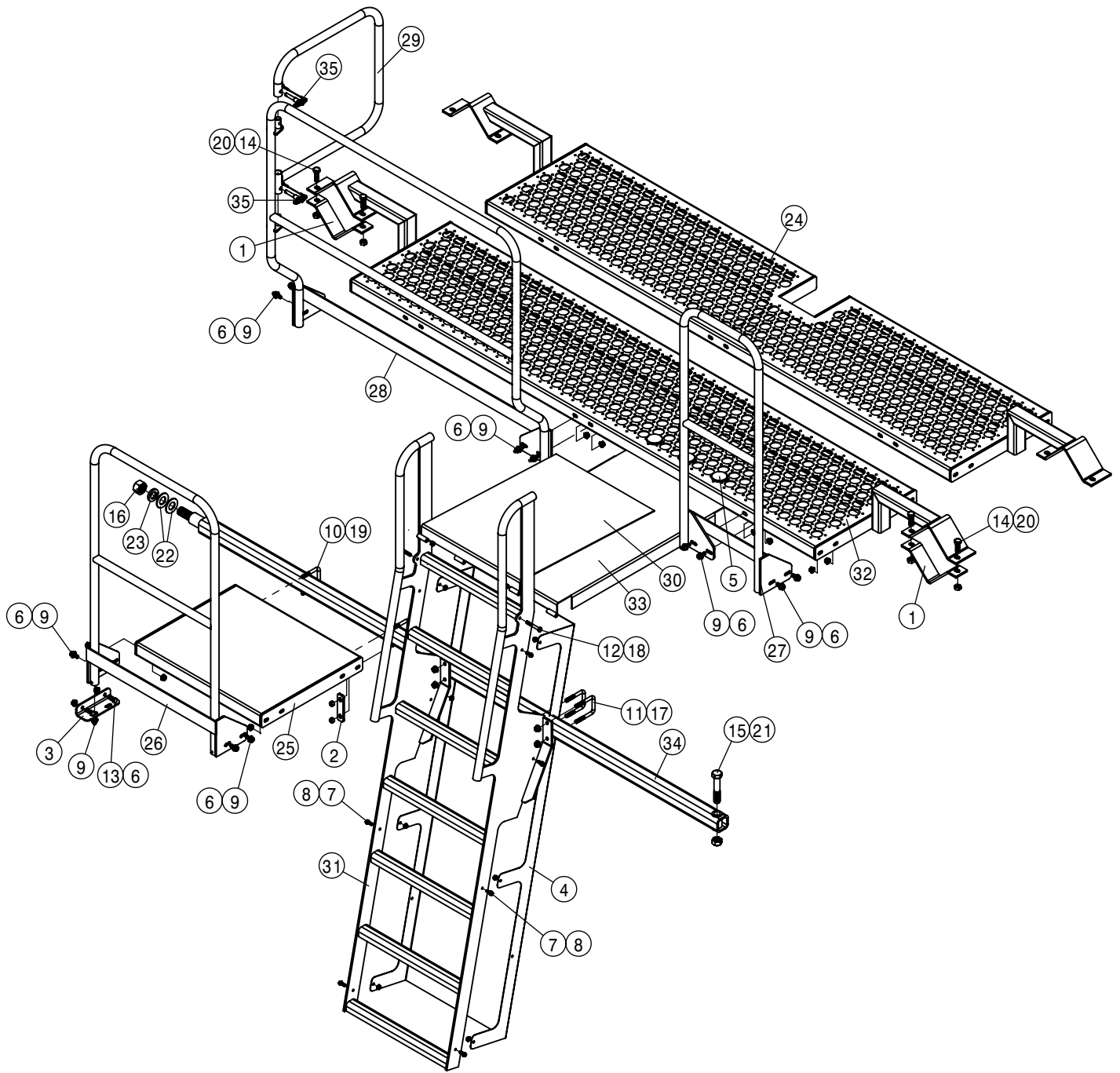

RH LADDER AND SERVICE PLATFORM ASSEMBLY			
DET	QTY	P/N	DESCRIPTION
1	2	341900	SERVICE PLATFORM MT KPR 90
2	2	343729	REAR PLATFORM U-BOLT BAR
3	1	343730	REAR PLATFORM SUPPORT ANGLE
4	1	343787	204 CE LADDER BACK STOP
5	3	343819	BRIDGE PLATE WEAR PUCK 204
6	14	470087	3/8UNC HEX SERR FLANGE NUT
7	8	470118	1/4 UNC X 3/4 SER FLG BOLT
8	8	470121	1/4 UNC SERR FLG LOCK NUT
9	13	470409	3/8UNC X 3/4 HHSFB GR5 MC
10	2	472040	3/8UNC-2.18ID-2.81 U-BOLT SQ
11	4	472051	3/8UNC-2ID-3.00 SQ U-BOLT MC, GR B7
12	2	900086	5/16UNC X 2 1/4 HEX BOLT
13	2	900129	3/8UNC X 1" HEX BOLT
14	4	900265	1/2UNC X 1 1/2 HEX BOLT
15	1	900410	3/4UNC X 4" HEX BOLT
16	1	910017	1" UNC HEX NUT
17	8	910106	3/8-16UNC CTRLK FLG NUT MC GR5

RH LADDER AND SERVICE PLATFORM ASSEMBLY			
DET	QTY	P/N	DESCRIPTION
18	2	914002	5/16UNC HEX STOVER NUT
19	4	914004	3/8UNC HEX STOVER NUT
20	4	914008	1/2 UNC HEX STOVER NUT
21	1	914012	3/4UNC HEX STOVER NUT
22	2	920008	1" SAE FLAT WASHER
23	1	920508	1" LOCK WASHER
24	1	343720	RH SERVICE PLATFORM WLD 204
25	1	343733	FUEL TANK PLATFORM 204 10
26	1	343735	REAR HANDRAIL WLDMNT
27	1	343737	RH FRT HANDRAIL WLD, 204
28	1	343739	RH REAR HANDRAIL WLD. 204
29	1	343770	REAR HR EXT WLDMT
30	1	343781	BRIDGE PLATE WELDMENT
31	1	343783	204 LADDER WELDMENT
32	1	343788	LH SERVICE PLTFRM WLDMT - CAB
33	1	343817	BRIDGE PLATE WELDMENT, 204SPW
34	1	358673	LEG BRACE WLD 200 92
35	2	470857	3/8"PIN,T-HANDLE QK-REL,W/LAN

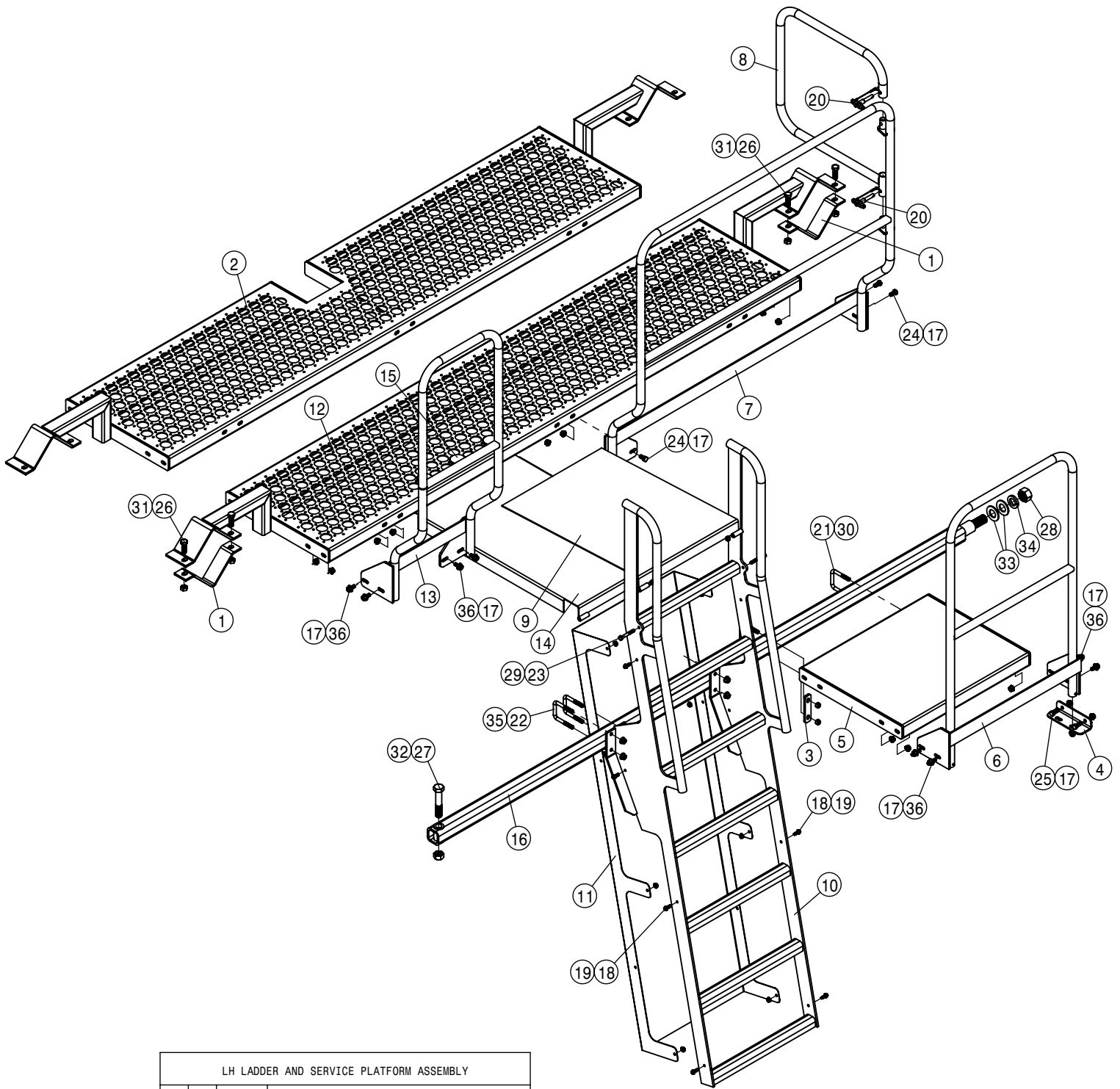

LH LADDER AND SERVICE PLATFORM ASSEMBLY			
DET	QTY	P/N	DESCRIPTION
1	2	341900	SERVICE PLATFORM MT KPR 90
2	1	343721	LH SERVICE PLATFORM WLD 204
3	2	343729	REAR PLATFORM U-BOLT BAR
4	1	343730	REAR PLATFORM SUPPORT ANGLE
5	1	343733	FUEL TANK PLATFORM 204 10
6	1	343735	REAR HANDRAIL WLDMNT
7	1	343740	LH REAR HANDRAIL WLD. 204
8	1	343770	REAR HR EXT WLDMT
9	1	343781	BRIDGE PLATE WELDMENT
10	1	343783	204 LADDER WELDMENT
11	1	343787	204 CE LADDER BACK STOP
12	1	343788	LH SERVICE PLTFRM WLDMT - CAB
13	1	343790	LH FRT HANDRAIL WLD,204SP '11
14	1	343817	BRIDGE PLATE WELDMENT, 204SPW
15	3	343819	BRIDGE PLATE WEAR PUCK 204
16	1	358673	LEG BRACE WLD 200 92
17	14	470087	3/8UNC HEX SERR FLANGE NUT
18	8	470118	1/4 UNC X 3/4 SER FLG BOLT
19	8	470121	1/4 UNC SERR FLG LOCK NUT

LH LADDER AND SERVICE PLATFORM ASSEMBLY			
DET	QTY	P/N	DESCRIPTION
20	2	470857	3/8"PIN,T-HANDLE QK-REL,W/LAN
21	2	472040	3/8UNC-2.18ID-2.81 U-BOLT SQ
22	4	472051	3/8UNC-2ID-3.00 SQ U-BOLT MC, GR B7
23	2	900086	5/16UNC X 2 1/4 HEX BOLT
24	4	900128	3/8UNC X 3/4 HEX BOLT
25	2	900129	3/8UNC X 1" HEX BOLT
26	4	900265	1/2UNC X 1 1/2 HEX BOLT
27	1	900410	3/4UNC X 4" HEX BOLT
28	1	910017	1" UNC HEX NUT
29	2	914002	5/16UNC HEX STOVER NUT
30	4	914004	3/8UNC HEX STOVER NUT
31	4	914008	1/2 UNC HEX STOVER NUT
32	1	914012	3/4UNC HEX STOVER NUT
33	2	920008	1" SAE FLAT WASHER
34	1	920508	1" LOCK WASHER
35	8	910106	3/8-16UNC CTRLK FLG NUT MC GR5
36	9	470409	3/8UNC X 3/4 HHSFB GR5 MC

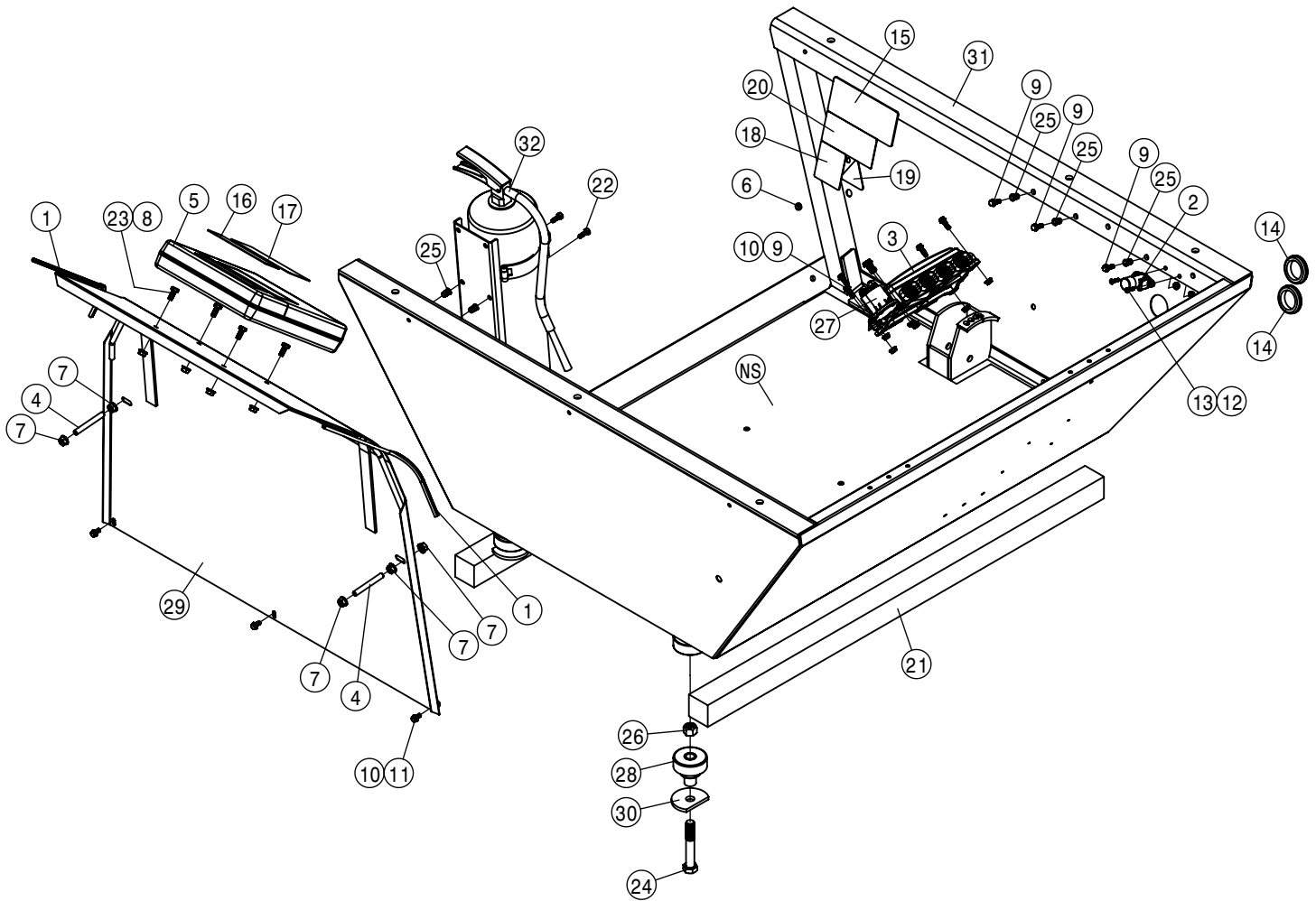

OPERATOR STATION ASSEMBLY			
DET	QTY	P/N	DESCRIPTION
1	2	193011	EDGE GUARD, BLK
2	1	290412	DIMMER SWITCH
3	1	292003	DVEC - INTERIOR '15
4	2	314929	3/8UNC X 3.00 STUD BOLT, FULL
5	1	343780	MANUAL HOLDER
6	1	470067	GROMMET, .250ID .125GW .375GD
7	6	470087	3/8UNC HEX SERR FLANGE NUT
8	4	470113	5/16UNC SERR FLG LOCK NUT
9	9	470118	1/4 UNC X 3/4 SER FLG BOLT
10	9	470121	1/4 UNC SERR FLG LOCK NUT
11	3	470122	1/4 UNC X 1/2 SERR FLG BOLT
12	2	470175	10-32 SERR FLANGE NUT
13	2	472235	10-32 X 3/4 PHIL HD MACH SCR
14	2	473915	GROMMET 1.500ID .062GW 1.750GD
15	1	650303	CUTTER ROTATION DECAL
16	1	650383	DECAL,HAGIE LOGO
17	1	650384	DECAL,MANUALS

OPERATOR STATION ASSEMBLY			
DET	QTY	P/N	DESCRIPTION
18	1	650388	DECAL,CAUTION,EMERGENCYSTOP '11
19	1	650389	DECAL, WARNING, HYD OIL INJ '11
20	1	650847	DECAL,CARRY PASSENGER WARNING
21	2	659704	FOAM 2" THK X 2" WIDE X 42" LG
22	2	900002	1/4UNC x 3/4 HEX BOLT
23	4	900064	5/16UNC X 3/4" HEX BOLT
24	4	900342	5/8UNC X 4" HEX BOLT
25	5	910127	1/4-20 NUTSERT .027-1.65 STL
26	4	914010	5/8UNC HEX STOVER NUT
27	1	292505	MCR
28	4	311051	RUBBER MOUNT, RB3-350
29	1	342098	NOISE DEFLECTOR WLD 204 01
30	4	343204	OP STATION WASHER, 204
31	1	362445	OP STN WLD, 204 14 (PAINTED)
32	1	490508	FIRE EXTINGUISHER 10LB ABC
NS	1	294408	HARNES, MAIN CAB INT. '18 204



330024-HEIGHT ADJ LATCH, SEAT 330022  
 330025-ADJ LATCH SPRING, SEAT 330022  
 330023-AIR BAG PKG, SEAT 330022

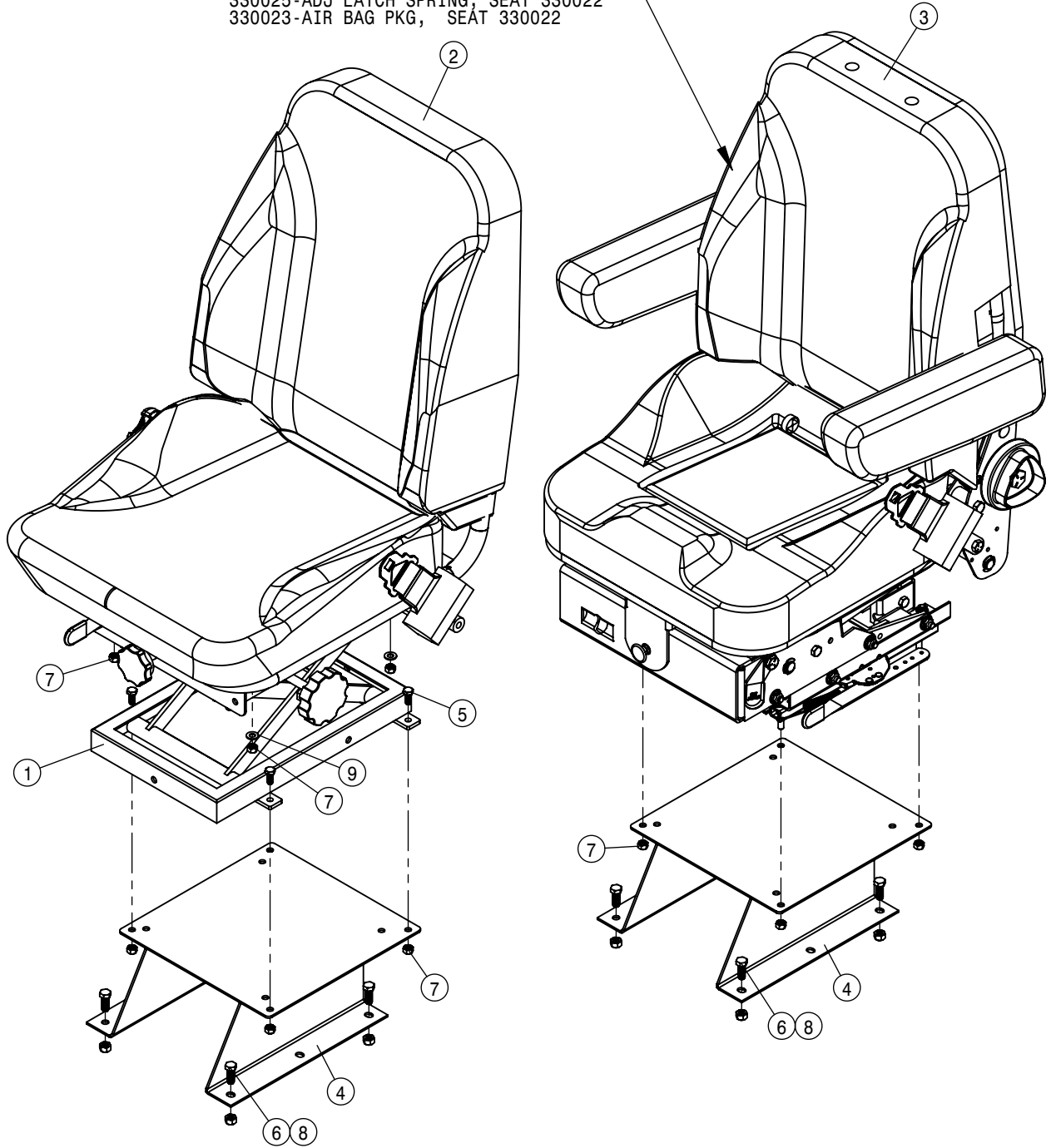

SEAT ASSEMBLY			
DET	QTY	P/N	DESCRIPTION
1	1	330015	SUSPENSION ASSY TRIMLINE SEAT
2	1	330043	SEAT,EVC MIDHIGH TRIMLINE (CE)
3	1	330044	SEAT, (FOR 204SP CAB) (CE)
4	2	341554	SEAT MT WLD TRIMLINE SEAT
5	4	900064	5/16UNC X 3/4" HEX BOLT
6	8	900129	3/8UNC X 1" HEX BOLT
7	12	914002	5/16UNC HEX STOVER NUT
8	8	914004	3/8UNC HEX STOVER NUT
9	2	920001	5/16 SAE FLAT WASHER

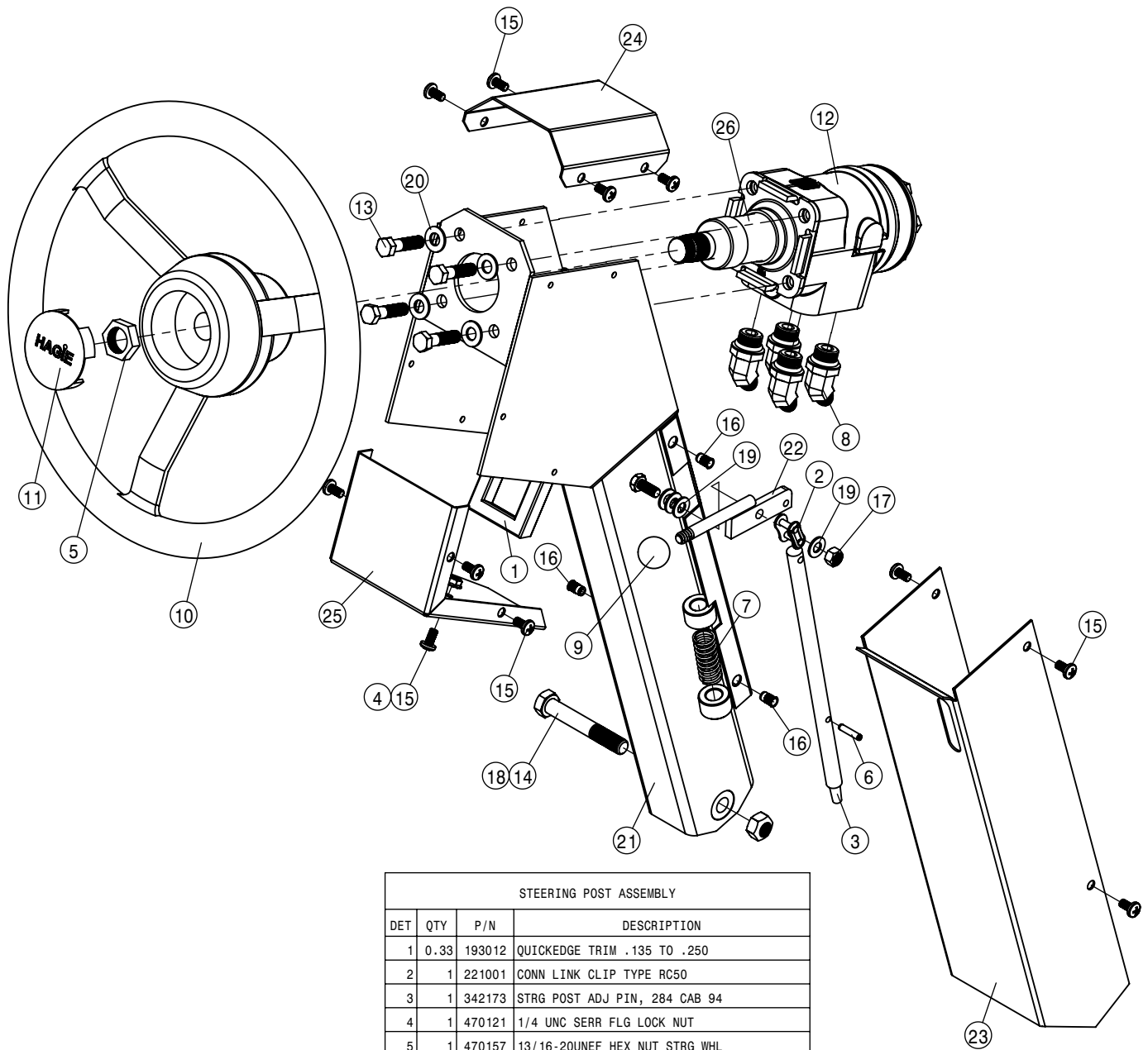

STEERING POST ASSEMBLY			
DET	QTY	P/N	DESCRIPTION
1	0.33	193012	QUICKEDGE TRIM .135 TO .250
2	1	221001	CONN LINK CLIP TYPE RC50
3	1	342173	STRG POST ADJ PIN, 284 CAB 94
4	1	470121	1/4 UNC SERR FLG LOCK NUT
5	1	470157	13/16-20UNEF HEX NUT STRG WHL
6	1	473928	ROLL PIN, 3/16DIA X 7/8
7	1	482131	3/4 X 1 3/4 COMPRSN SPRING
8	4	618496	9/16MJIC-45-3/4MOR LBO
9	1	659291	KNOB, BLK, 3/8" - 16 UNC
10	1	749294	STEERING WHL, VIP 14"
11	1	749295	STEER WHL CAP W/ HAGIE EMB
12	1	749318	STRG MTR, 7.3CID, NON-LOAD 1031
13	4	900131	3/8UNC X 1 1/2 HEX BOLT
14	1	900271	1/2UNC X 3 1/4 HEX BOLT
15	13	903708	1/4UNC X1/2PHIL PANHD MACH SCR
16	4	910130	10-32 NUTSERT .020-.130 STL
17	1	914002	5/16UNC HEX STOVER NUT
18	1	914008	1/2 UNC HEX STOVER NUT
19	4	920001	5/16 SAE FLAT WASHER
20	4	920002	3/8 SAE FLAT WASHER
21	1	342165	STRG POST WLD, 284 CAB 94
22	1	342174	STRG POST ADJ PIN LEVER WLD 94
23	1	342177	STRG POST COVER, 284 CAB 94
24	1	342178	UPR STRG MTR HSNQ COVER 94
25	1	362490	LWR STRG MTR HSNQ COVER 14
26	1	749178	STRG COLUMN 2.5IN LONG

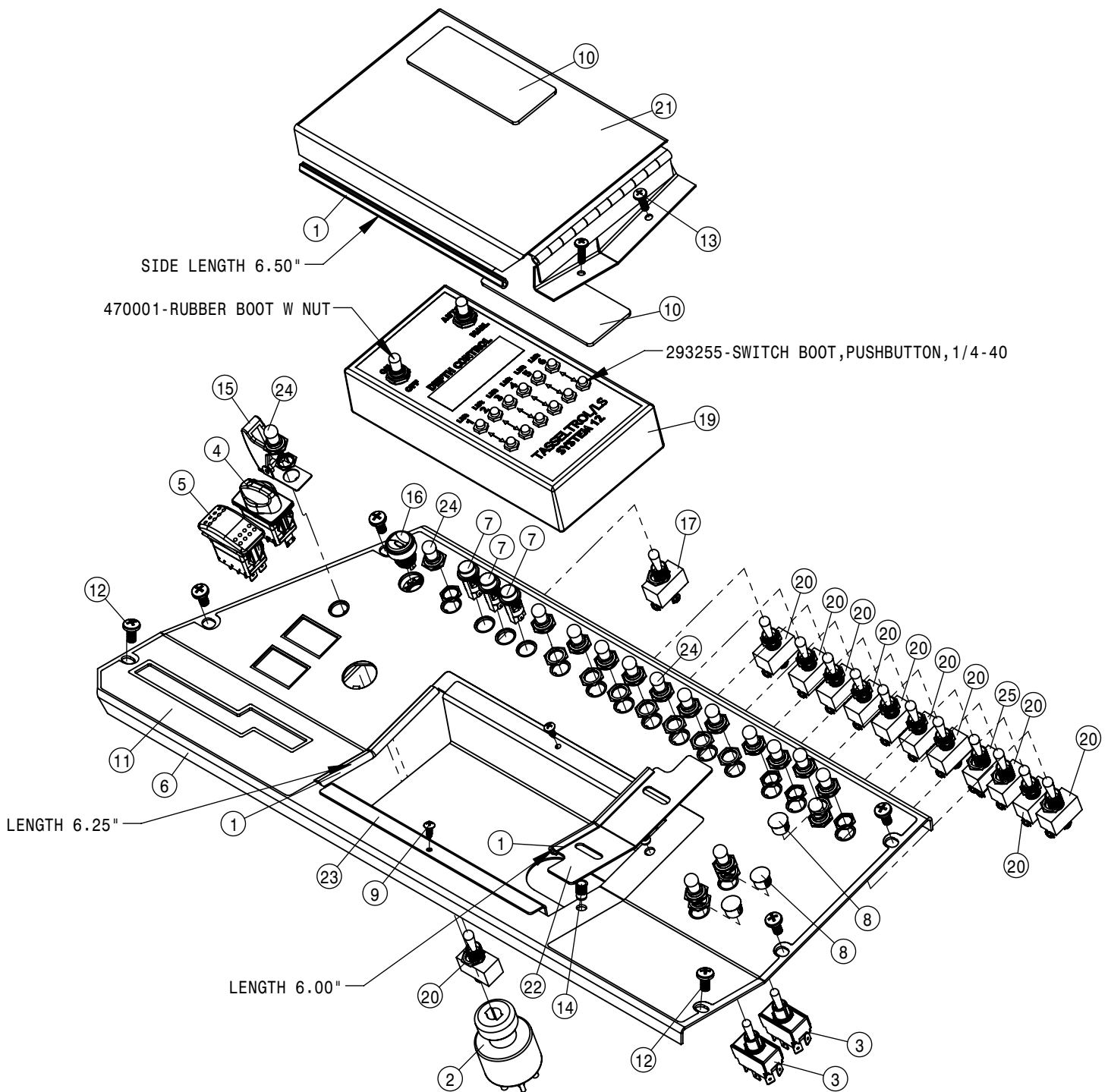

SIDE LENGTH 6.50"

470001-RUBBER BOOT W NUT

293255-SWITCH BOOT,PUSHBUTTON, 1/4-40

LENGTH 6.25"

LENGTH 6.00"

CONSOLE COVER ASSEMBLY			
DET	QTY	P/N	DESCRIPTION
1	5	193011	EDGE GUARD, BLK
2	1	290073	IGN SWITCH, SEALED 4 POSITION
3	2	293038	TOGGLE SWITCH DPDT 15 AMP
4	1	294055	SWITCH-ROTARY TURN SIGNAL
5	1	294057	SWITCH-DP LIGHTS
6	1	317634	CONSOLE PANEL, 204SP '14
7	3	390318	INDICATOR LIGHT, RED
8	3	470224	SNAP PLUG, BLK NYL, .50 DIA
9	2	473902	#8 X 1/2 PHIL PAN HD MTL SCR
10	2	650379	DECAL,ENGAGE DET HD HYD MTRS
11	1	650481	DECAL,CONSOLE COVER 204SP '15
12	6	903708	1/4UNC X1/2PHIL PANHD MACH SCR
13	2	903710	10-32 X 5/8 PHIL PANHD MACH SCR
14	2	910130	10-32 NUTSERT .020-.130 STL

CONSOLE COVER ASSEMBLY			
DET	QTY	P/N	DESCRIPTION
15	1	291655	AIRCRAFT TOGGLE SWITCH GUARD
16	1	292504	HORN SWITCH
17	1	292560	TOGGLE SWITCH MOMENTARY SPST
NS	1	293686	OUTRGR FOLD VLV HARNESS,SW PNL
19	1	294035	LS CTRL 6L DISPLAY BOX ASSY
20	11	298012	TOGGLE SWITCH SPST
21	1	342240	CONTROL BOX COVER WLD, 204 94
22	1	342244	CONTROL BOX KEEPER, 204 94
23	1	342297	LS CTRL 6L DISPLAY BOX MT
24	16	470001	RUBBER BOOT AND NUT FOR 298012
25	1	610412	TOGGLE SWITCH FOR FUEL VLV
NS	1	294408	HARNESS, MAIN CAB INT. '18 204

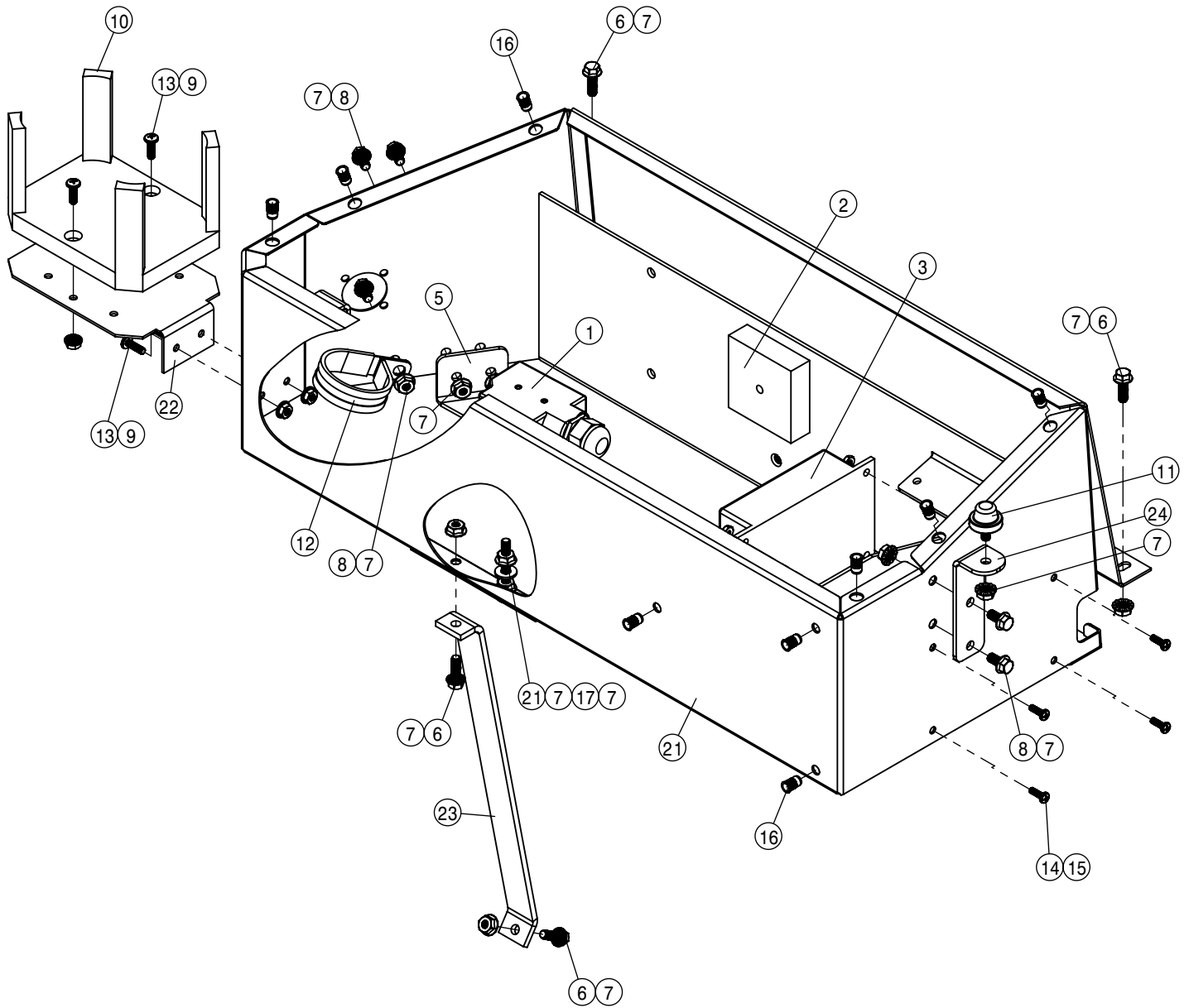

CONSOLE ASSEMBLY			
DET	QTY	P/N	DESCRIPTION
1	1	290064	SWITCH, BACK-UP
2	1	290065	TIMER BLOCK
3	1	291910	FLASHER, SOLID STATE, 12V
NS	1	293985	CONSOLE PWR, GND CABLE ASSY '10
5	1	343769	BACK UP SIG BRKT, 204SP
6	4	470118	1/4 UNC X 3/4 SER FLG BOLT
7	13	470121	1/4 UNC SERR FLG LOCK NUT
8	5	470122	1/4 UNC X 1/2 SERR FLG BOLT
9	4	470175	10-32 SERR FLANGE NUT
10	1	470214	SPILLMASTER DRINK HOLDER
11	1	470230	1/2 RUBBER BUMPER, 1/4-20 STUD
12	1	520126	CUSH CLAMP, #32 2IN X 5/8W
13	4	903710	10-32 X 5/8 PHIL PANHD MACH SCR

CONSOLE ASSEMBLY			
DET	QTY	P/N	DESCRIPTION
14	4	903844	8-32 X 1/2 PHIL PANHD MACH SCR
15	4	910024	8-32 HEX NUT
16	9	910130	10-32 NUTSERT .020-.130 STL
17	1	920000	1/4 SAE FLAT WASHER
NS	1	293907	CANTRAK HARNESS 204SP
NS	1	294300	BATT CABLE, RED 20*6GA. .312-.312
NS	1	294301	BATT CABLE, RED 13*6GA. .312-.312
21	1	317638	CONSOLE WLD, 204 T3
22	1	342216	DRINK HOLDER MT BRKT 94
23	1	342248	CONSOLE BRACE, 204 94
24	1	317429	CONSOLE LID BUMPER BRKT

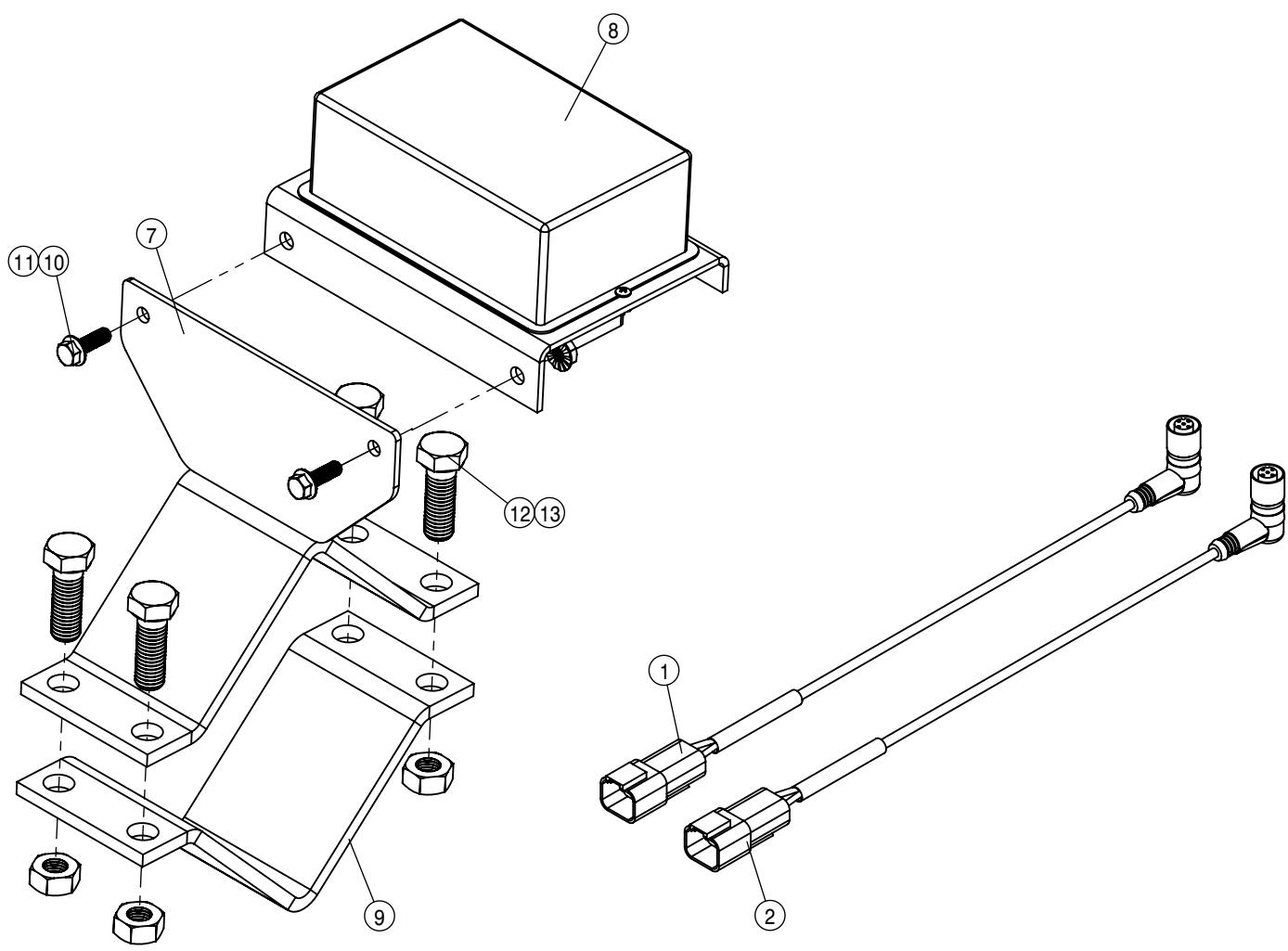

DETASSELER MODULE ASSEMBLY			
DET	QTY	P/N	DESCRIPTION
1	1	292583	SENSOR HARNESS FOR AWS
2	1	294049	SENSOR HARNESS FOR SIE
NS	1	294038	COMBO LIFT HARNESS
NS	1	294037	COMBO/204 PHOTO EYE HARNESS
NS	1	294051	204 SIE CAB TASSEL TROL HARNESS
NS	1	294050	204 CAB JUMPER HARNESS
7	1	438789	DETASSLER MODULE BRKT WLD
8	1	294034	DETASSLER MODULE
9	1	438324	75IN OUTRGR BRACE CLAMP (PAINT)
10	2	470118	1/4 UNC X 3/4 SER FLG BOLT
11	2	470121	1/4 UNC SERR FLG LOCK NUT
12	4	900265	1/2UNC X 1 1/2 HEX BOLT
13	4	914008	1/2 UNC HEX STOVER NUT

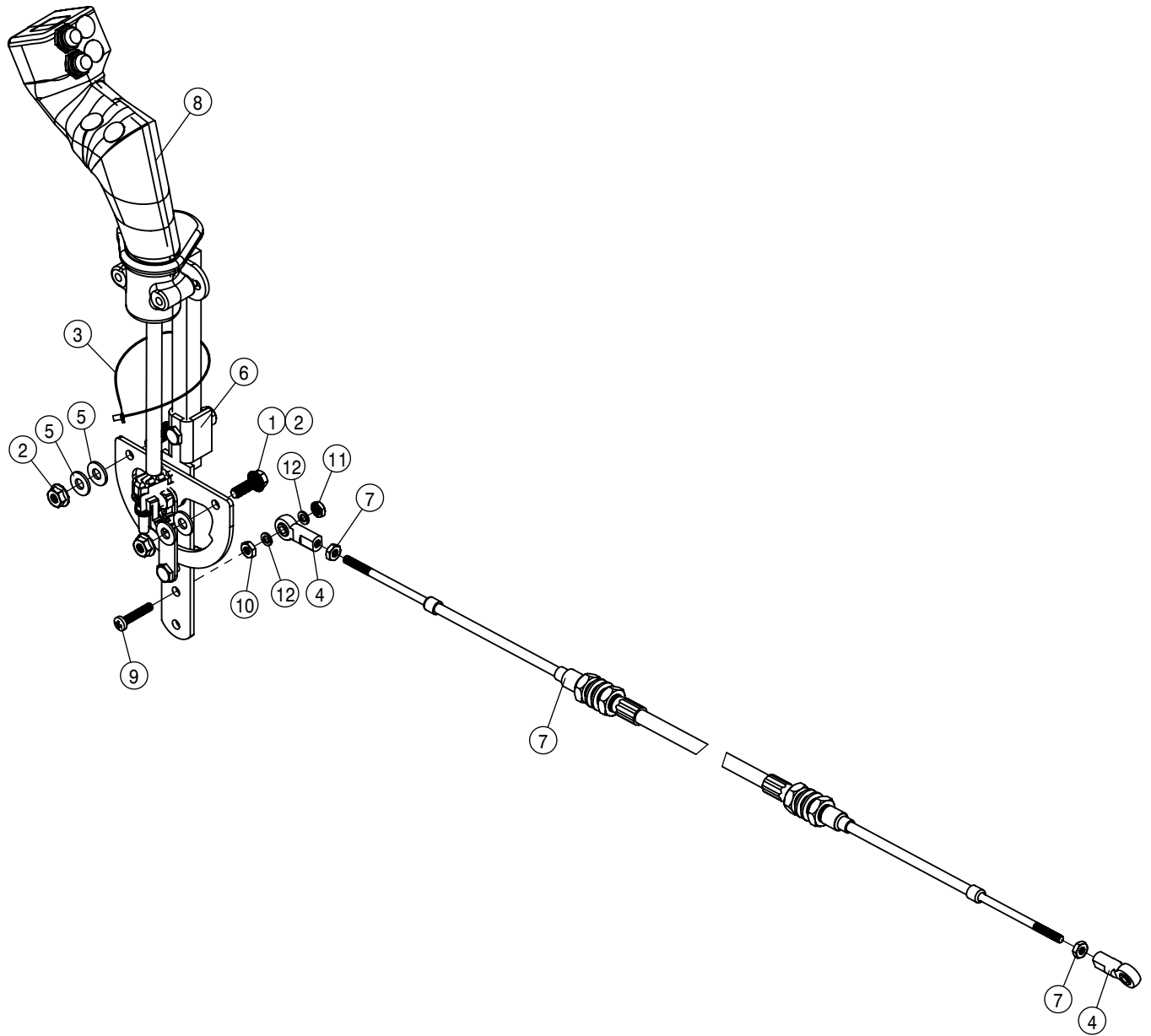

HYDROSTATIC LEVER ASSEMBLY			
DET	QTY	P/N	DESCRIPTION
1	2	470118	1/4 UNC X 3/4 SER FLG BOLT
2	2	470121	1/4 UNC SERR FLG LOCK NUT
3	1	470609	8" BEAD CHAIN
4	2	473921	BALL JOINT NO 10-32 THD
5	4	920000	1/4 SAE FLAT WASHER
6	1	606907	HYDST CTRL LEVER WLD 204-284
7	1	785003	CTRL CABLE 10-32 4IN X 112 LG
8	1	785077	FASSE EZ-3 CONTROL HANDLE,204
9	1	903893	10-32 X 1" PHIL PAN MACH SCR
10	1	910027	10-32 HEX NUT
11	1	914027	10-32 HEX STOVER NUT
12	2	920510	#10 LOCK WASHER

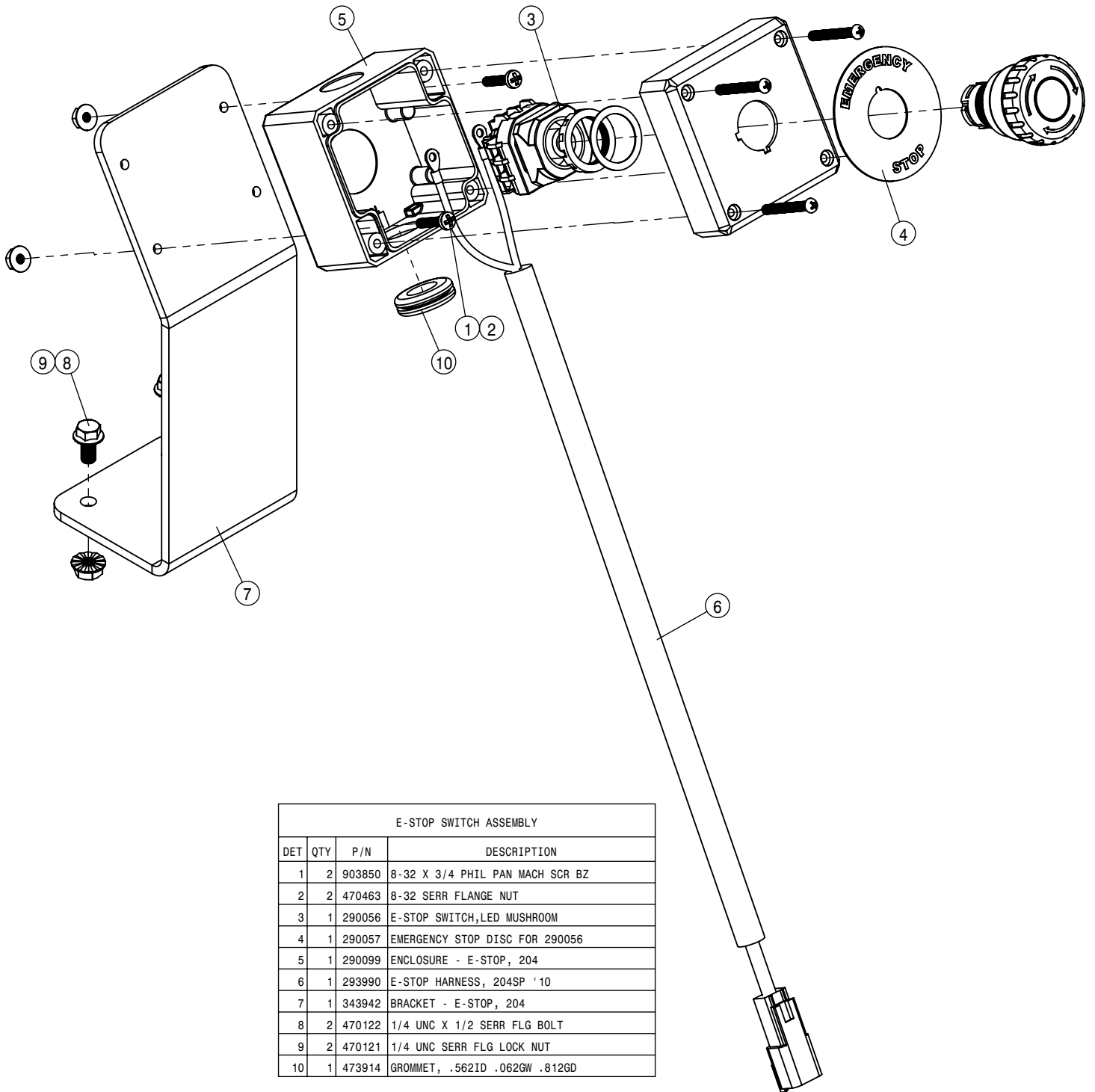

E-STOP SWITCH ASSEMBLY			
DET	QTY	P/N	DESCRIPTION
1	2	903850	8-32 X 3/4 PHIL PAN MACH SCR BZ
2	2	470463	8-32 SERR FLANGE NUT
3	1	290056	E-STOP SWITCH,LED MUSHROOM
4	1	290057	EMERGENCY STOP DISC FOR 290056
5	1	290099	ENCLOSURE - E-STOP, 204
6	1	293990	E-STOP HARNESS, 204SP '10
7	1	343942	BRACKET - E-STOP, 204
8	2	470122	1/4 UNC X 1/2 SERR FLG BOLT
9	2	470121	1/4 UNC SERR FLG LOCK NUT
10	1	473914	GROMMET, .562ID .062GW .812GD

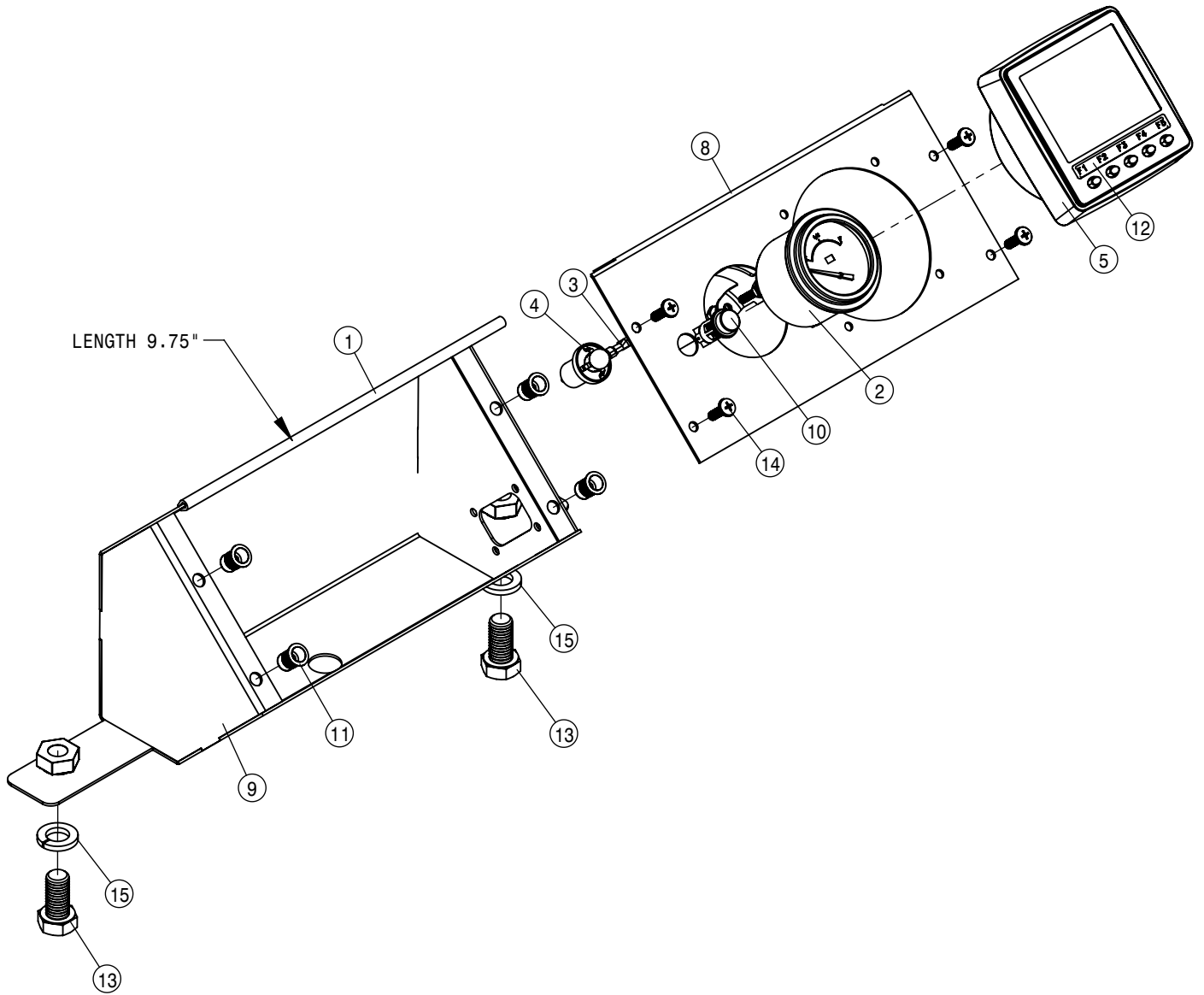

CANTRAK ASSEMBLY			
DET	QTY	P/N	DESCRIPTION
1	1	193011	EDGE GUARD, BLK
2	1	290401	FUEL GAUGE FOR 2.125 DIA HOLE
3	1	291571	TYCO,FASTON, .250(16-14GA),FEM
4	1	291612	LIGHT KIT FOR 2" GAUGE
5	1	292236	VEECAN 320 DISPLAY
NS	1	293907	CANTRAK HARNESS 204SP
NS	1	293985	CONSOLE PWR, GND CABLE ASSY'10
8	1	317635	CANTRAK PANEL, 204SP '14
9	1	343801	CANTRAK HSG WLD, 204SP
10	1	390318	INDICATOR LIGHT, RED
11	4	910127	1/4-20 NUTSERT .027-1.65 STL
12	1	650270	DECAL,CANTRAK FUNCTION KEY
13	2	900263	1/2UNC X 1" HEX BOLT
14	4	903710	10-32 X 5/8 PHIL PANHD MACH SCR
15	2	920504	1/2 LOCK WASHER



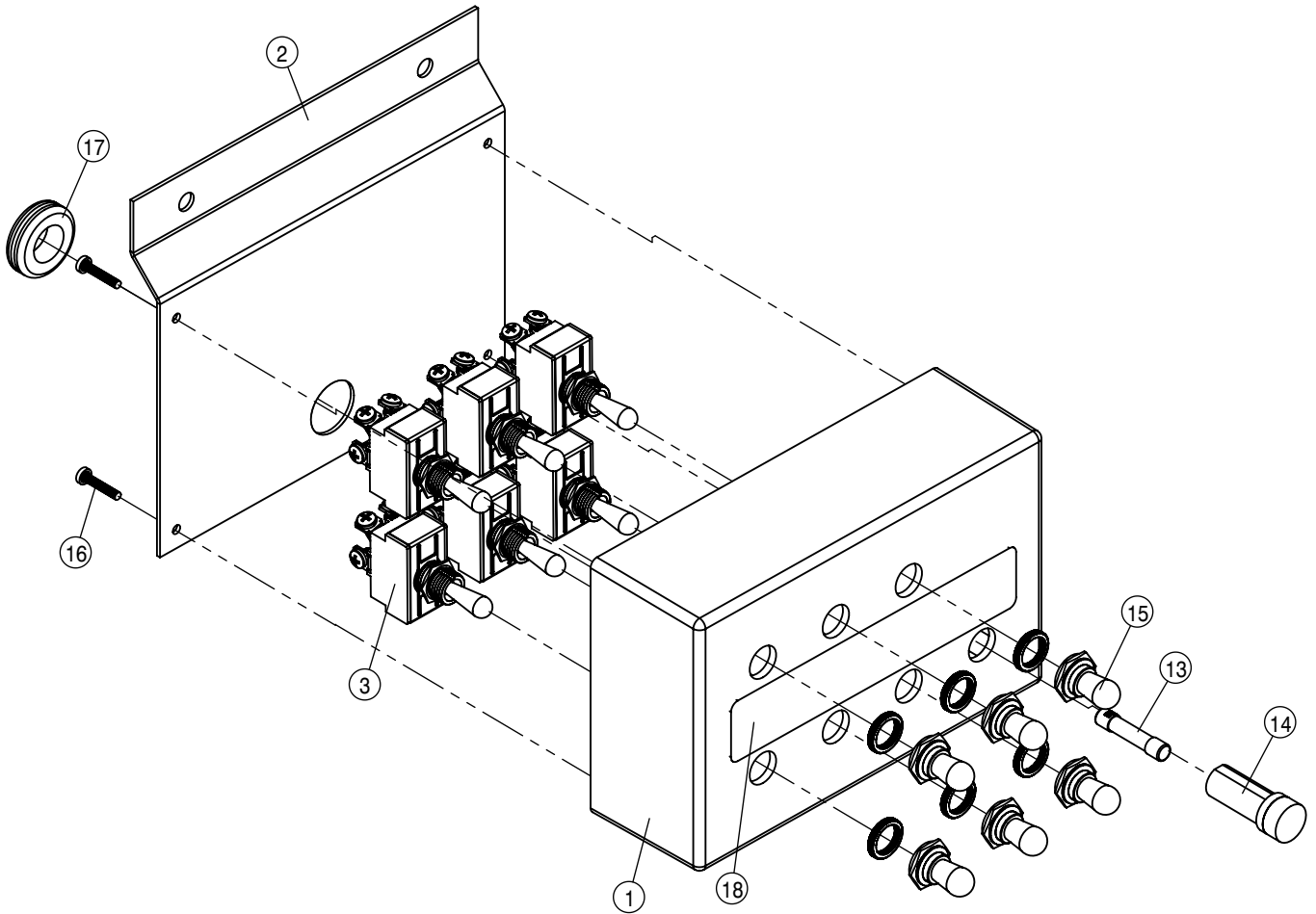

6-LIFT, DEPTH COMMAND SWITCH ASSEMBLY			
DET	QTY	P/N	DESCRIPTION
1	1	002896	SWITCH BOX, 5/6L DEPTH CMD 96
2	1	002897	SWITCH BOX, 5/6L DEPTH CMD 96
3	6	293172	TOGGLE SWITCH DPDT W/JUMPERS
NS	1	293331	144" WIRE ASSY, DEPTH CTRL 94
NS	1	293332	168" WIRE ASSY, DEPTH CTRL 94
NS	1	293333	244" WIRE ASSY, DEPTH CTRL 94
NS	1	293334	270" WIRE ASSY, DEPTH CTRL 94
NS	1	293338	16GA BLK-291580-293147-20 W/A
NS	1	293368	6L DEPTH CMD POS WIRE ASSY
NS	1	293369	6L DEPTH CMD NEG WIRE ASSY
NS	1	293370	288" WIRE ASSY, DEPTH CTRL 96
NS	1	293371	336" WIRE ASSY, DEPTH CTRL 96
13	1	298003	FUSE 15 AMP
14	1	298011	FUSE HOLDER
15	6	470001	RUBBER BOOT AND NUT FOR 298012
16	4	473829	3MM-0.50 X 16MM PAN HD SCR
17	1	473914	GROMMET, .562ID .062GW .812GD
18	1	650338	DECAL,DEPTH CMD 6-LIFT

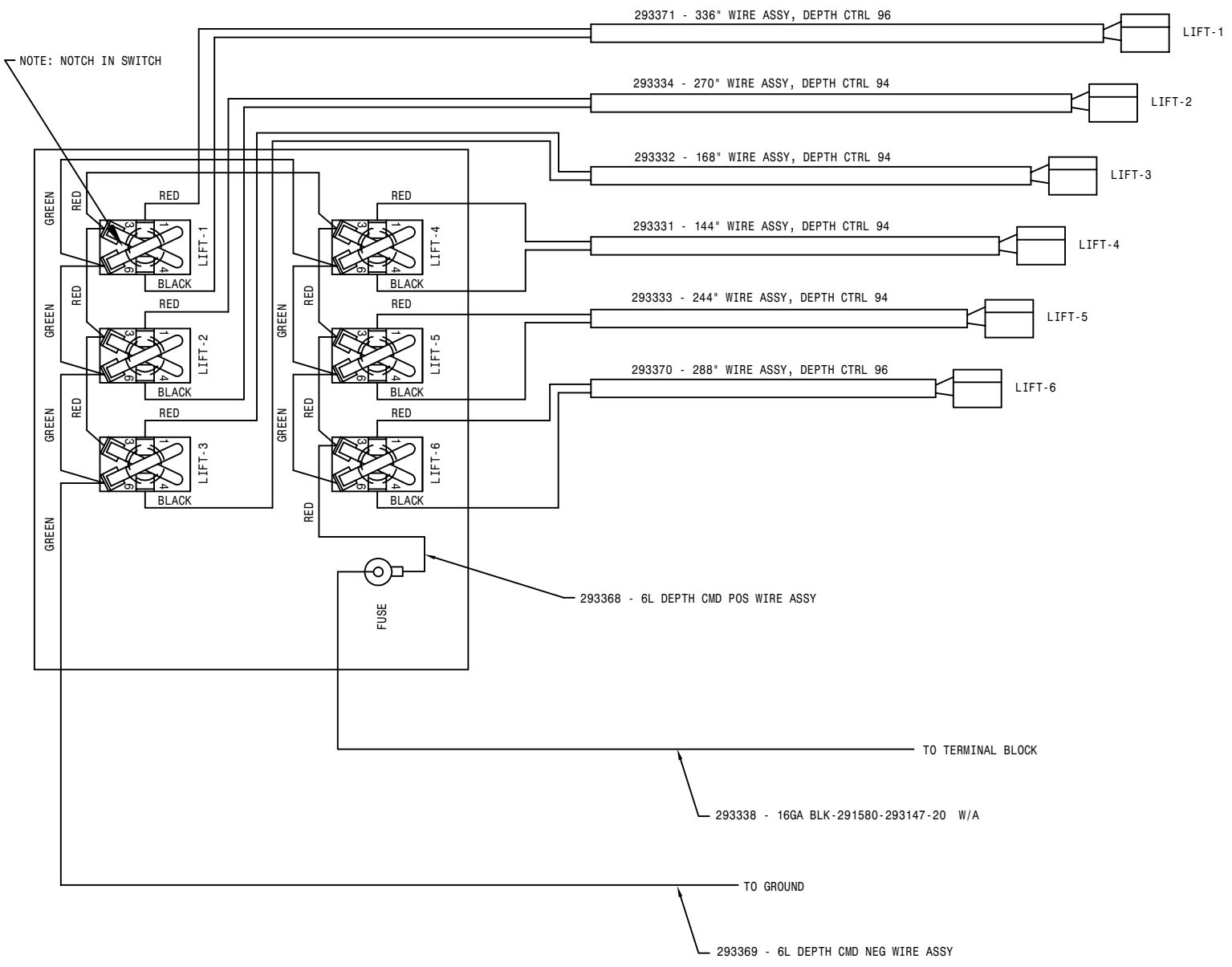

DET	REQ	DESCRIPTION
<b>HAGIE</b>		
HAGIE MANUFACTURING COMPANY CLARION, IOWA 50525		
REMOVE ALL SHARP CORNERS & BURRS		
TOLERANCE UNLESS OTHERWISE SPECIFIED		
FRACTION ±1/32	DECIMALS X.XX ±.03 X.XXX ±.005	ANGLES ±1°
DESCRIPTION WIRE DIAG, 6-LIFT DEPTH CMD 96		
DRAWN BY	SCALE	
1: MARKER	NONE (1)	
CHECKED BY	APPROVED BY	
DATE 02-26-96	DRAWING NUMBER 498479	
SHEET	OF	

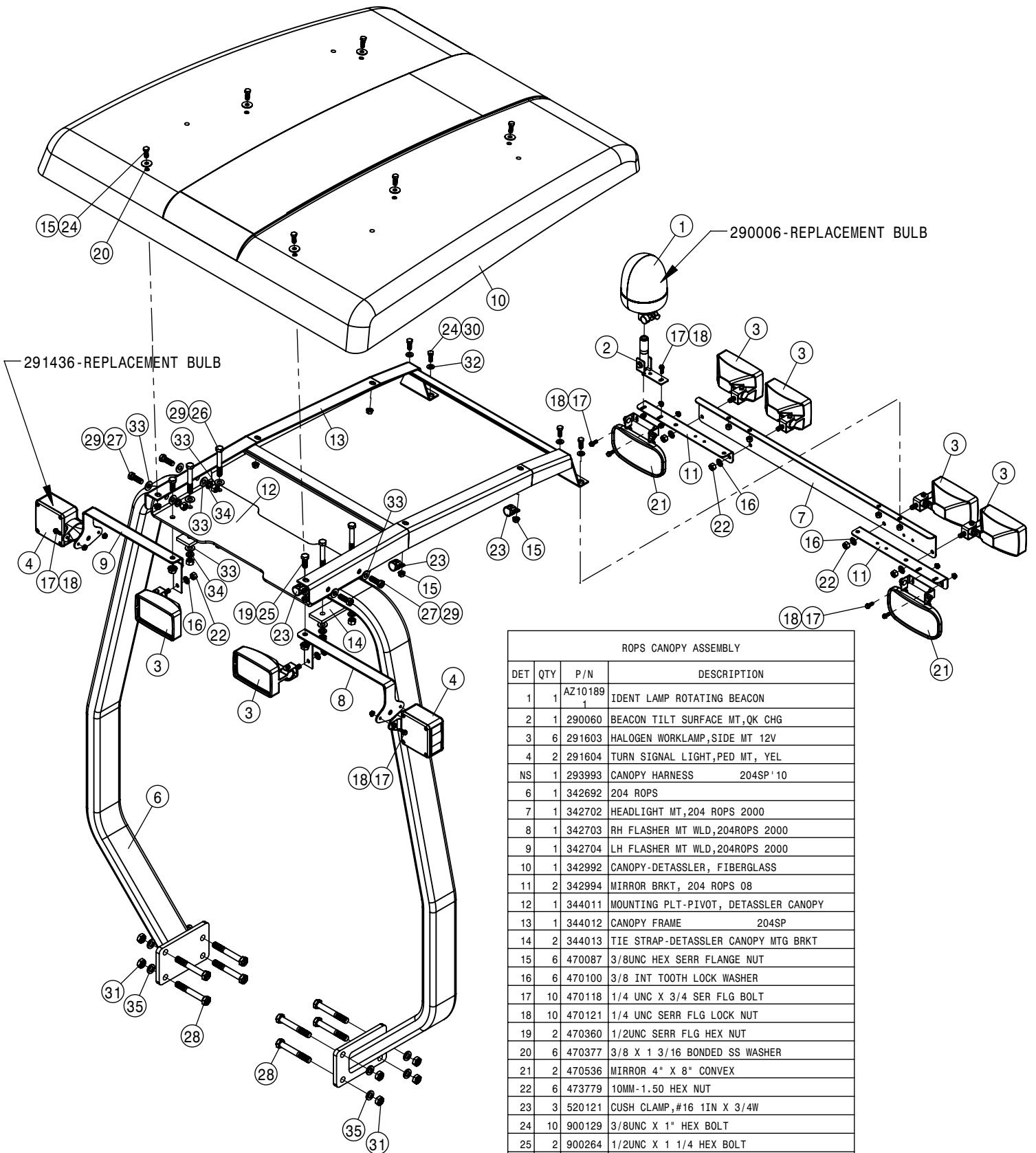

ROPS CANOPY ASSEMBLY			
DET	QTY	P/N	DESCRIPTION
1	1	AZ10189	IDENT LAMP ROTATING BEACON
2	1	290060	BEACON TILT SURFACE MT,QK CHG
3	6	291603	HALOGEN WORKLAMP, SIDE MT 12V
4	2	291604	TURN SIGNAL LIGHT, PED MT, YEL
NS	1	293993	CANOPY HARNESS 204SP'10
6	1	342692	204 ROPS
7	1	342702	HEADLIGHT MT, 204 ROPS 2000
8	1	342703	RH FLASHER MT WLD, 204ROPS 2000
9	1	342704	LH FLASHER MT WLD, 204ROPS 2000
10	1	342992	CANOPY-DETASSLER, FIBERGLASS
11	2	342994	MIRROR BRKT, 204 ROPS 08
12	1	344011	MOUNTING PLT-PIVOT, DETASSLER CANOPY
13	1	344012	CANOPY FRAME 204SP
14	2	344013	TIE STRAP-DETASSLER CANOPY MTG BRKT
15	6	470087	3/8UNC HEX SERR FLANGE NUT
16	6	470100	3/8 INT TOOTH LOCK WASHER
17	10	470118	1/4 UNC X 3/4 SER FLG BOLT
18	10	470121	1/4 UNC SERR FLG LOCK NUT
19	2	470360	1/2UNC SERR FLG HEX NUT
20	6	470377	3/8 X 1 3/16 BONDED SS WASHER
21	2	470536	MIRROR 4" X 8" CONVEX
22	6	473779	10MM-1.50 HEX NUT
23	3	520121	CUSH CLAMP, #16 1IN X 3/4W
24	10	900129	3/8UNC X 1" HEX BOLT
25	2	900264	1/2UNC X 1 1/4 HEX BOLT
26	4	900272	1/2UNC X 3 1/2 HEX BOLT
27	4	900804	1/2UNC X 1 1/2 HEX BOLT GR8 YZ
28	8	900847	5/8UNC X 4 1/2 HEX BOLT GR8 YZ
29	8	910008	1/2UNC HEX NUT
30	4	914004	3/8UNC HEX STOVER NUT
31	8	914814	5/8UNC HEX NUT GR8
32	4	920002	3/8 SAE FLAT WASHER
33	16	920004	1/2 SAE FLAT WASHER
34	8	920504	1/2 LOCK WASHER
35	8	920505	5/8 LOCK WASHER

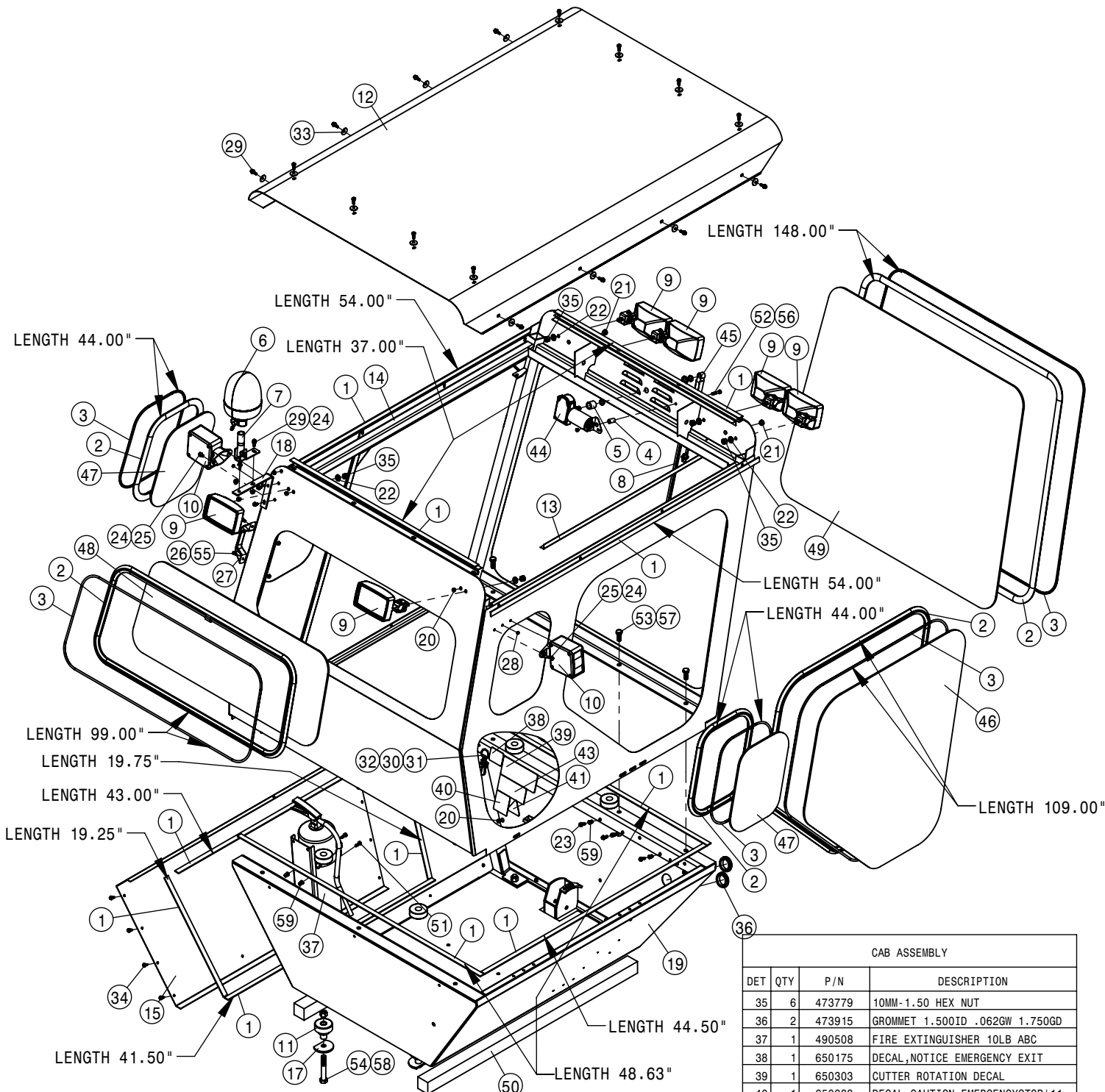

CAB ASSEMBLY			
DET	QTY	P/N	DESCRIPTION
1	11	193037	STICKERTITE 1/8 X 3/4
2	5	193044	WINDOW WEATHERSTRIP
3	5	193045	LOCK STRIP FOR 193044
4	1	200019	.25 SCH40 BP X 1.00 LG C/L
5	1	202037	WINDSHIELD WIPER SPACER
6	1	AZ101891	IDENT LAMP ROTATING BEACON
7	1	290060	BEACON TILT SURFACE MT,QK CHG
8	1	290417	18" WIPER BLADE
9	6	291603	HALOGEN WORKLAMP, SIDE MT 12V
10	2	291604	TURN SIGNAL LIGHT, PED MT, YEL
11	4	311051	RUBBER MOUNT, RB3-350
12	1	342150	CAB ROOF WLD, 284 94
13	1	342180	HD LINER KPR ANGLE, 284 CAB 94
14	1	342287	204 CAB WELDMT
15	1	342295	LH SIDE PANEL, 204 CAB 95
NS	2	342333	NYL HOSE SLEEVE, 2.64ID X 12.00
17	4	343204	OP STATION WASHER, 204

CAB ASSEMBLY			
DET	QTY	P/N	DESCRIPTION
18	1	343839	BEACON MNT BRKT, 204SP
19	1	362444	OP STN WLD, 204 14 (BARE)
20	4	470067	GROMMET, .250ID .125GW .375GD
21	2	470070	GROMMET, .375ID .062GW .500GD
22	6	470100	3/8 INT TOOTH LOCK WASHER
23	3	470118	1/4 UNC X 3/4 SER FLG BOLT
24	6	470121	1/4 UNC SERR FLG LOCK NUT
25	6	470122	1/4 UNC X 1/2 SERR FLG BOLT
26	2	470175	10-32 SERR FLANGE NUT
27	1	470222	GRAB HANDLE, BLACK MOLDED
28	2	470226	GROMMET, .156ID .062GW .250GD
29	10	470118	1/4UNC X 3/4 HHSFB GR5 MC
30	1	470397	RES-Q-ME TOOL
31	1	470398	BEAD CHAIN, #10 X 4" LONG
32	1	470400	BEAD CHAIN CONNECTOR #10 WHITE
33	16	470514	1/4 X 1 SEALING WASHER
34	10	472349	1/4 X 3/4 20THD-IN TEK TYPE

CAB ASSEMBLY			
DET	QTY	P/N	DESCRIPTION
35	6	473779	10MM-1.50 HEX NUT
36	2	473915	GROMMET 1.500ID .062GW 1.750GD
37	1	490508	FIRE EXTINGUISHER 10LB ABC
38	1	650175	DECAL, NOTICE EMERGENCY EXIT
39	1	650303	CUTTER ROTATION DECAL
40	1	650388	DECAL, CAUTION, EMERGENCY STOP' 11
41	1	650389	DECAL, WARNING, HYD OIL INJ' 11
NS	2	650524	204 CAB MIRRORS
43	1	650847	DECAL, CARRY PASSENGER WARNING
44	1	658008	WINDSHIELD WIPER MOTOR
45	1	658013	WIPER ARM
46	1	658015	FRONT SIDE CAB/DOOR GLASS 94
47	2	658016	REAR SIDE CAB GLASS 94
48	1	658017	REAR CAB GLASS 94
49	1	658018	FRONT CAB GLASS, 204 95
50	2	659704	FOAM 2" THK X 2" WIDE X 42" LG
51	10	900002	1/4UNC x 3/4 HEX BOLT
52	1	900005	1/4UNC X 1 1/2 HEX BOLT
53	6	900264	1/2UNC X 1 1/4 HEX BOLT
54	4	900342	5/8UNC X 4" HEX BOLT
55	2	903883	10-32 X 1/2 PHIL PAN MACH SCR
56	1	914000	1/4UNC HEX STOVER NUT
57	6	914008	1/2 UNC HEX STOVER NUT
58	4	914010	5/8UNC HEX STOVER NUT
59	5	910127	1/4-20 NUTSERT .027-1.65 STL

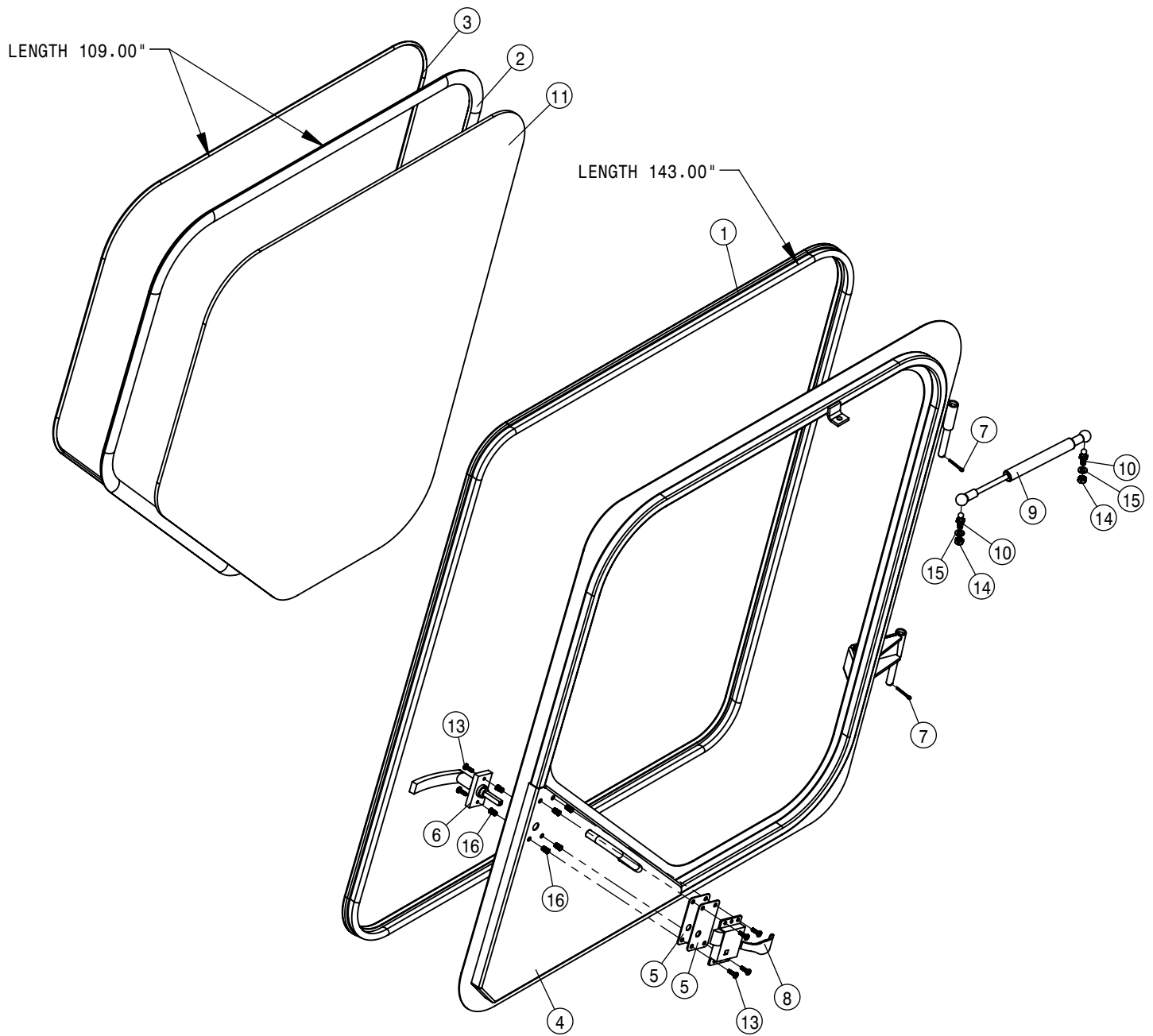

DOOR ASSEMBLY			
DET	QTY	P/N	DESCRIPTION
1	1	193028	PUSH-ON TRIM SEAL RS-130-FX
2	1	193044	WINDOW WEATHERSTRIP
3	1	193045	LOCK STRIP FOR 193044
4	1	342153	LH DOOR WLD, 284 CAB 94
5	2	342163	CAB DOOR LATCH SHIM, .06 94
6	1	342217	DOOR HANDLE, 254-284 CAB 94
7	2	470006	1/8 X 1 COTTER PIN
8	1	470219	CAB LOCK, LH #55
9	1	470221	GAS SPRING, 60LB 3.5 STROKE
10	2	470255	BALL STUD, 5/16-18 THRD X 10MM
11	1	658015	FRONT SIDE CAB/DOOR GLASS 94
NS	2	485052	POP RIVET 1/8 X 3/8
13	6	903710	10-32 X 5/8 PHIL PANHD MACH SCR
14	2	910002	5/16UNC HEX NUT
15	2	920501	5/16 LOCK WASHER
16	6	910130	10-32 NUTSERT .020-.130 STL

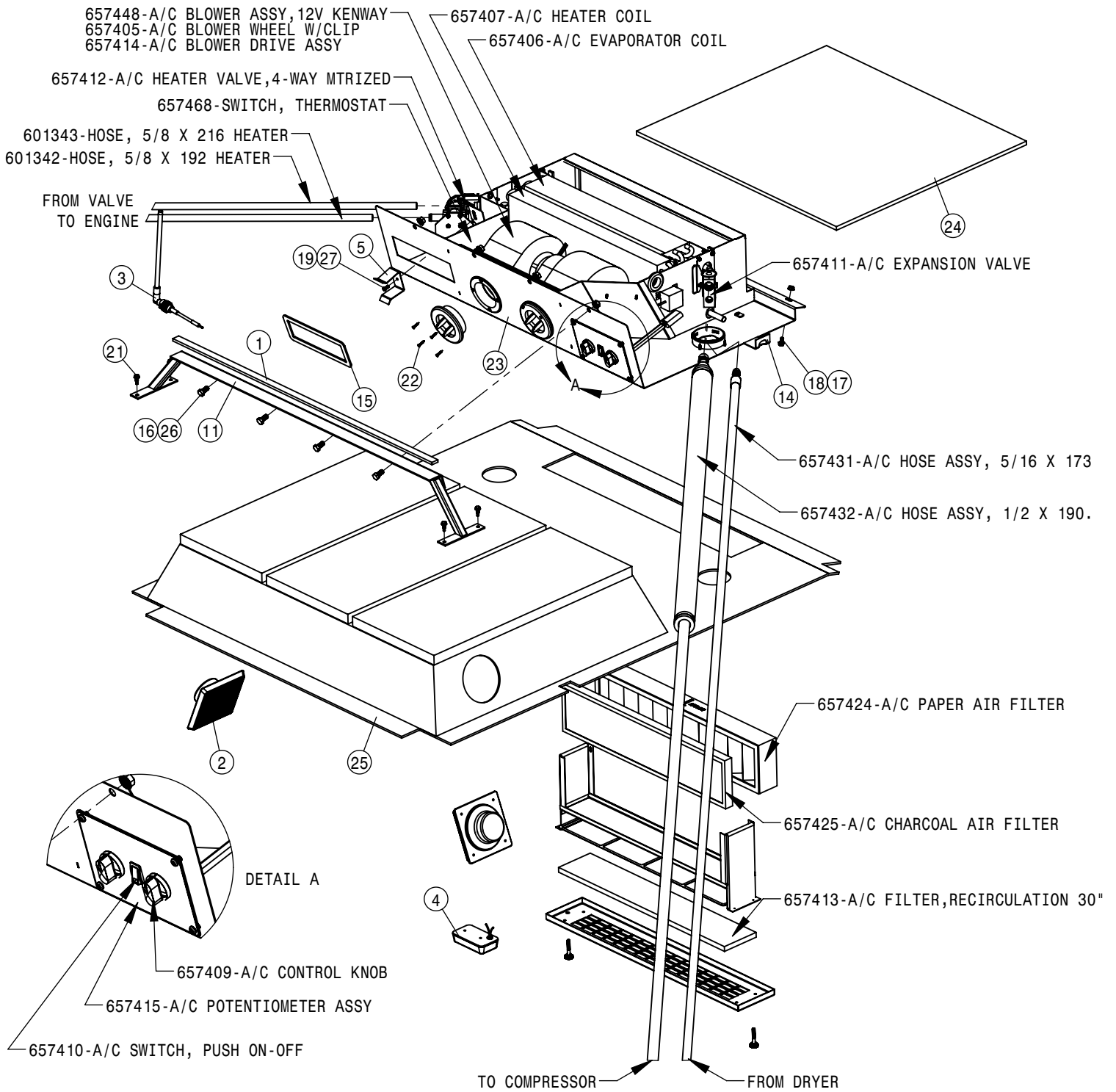

AIR CONDITIONER ASSEMBLY			
DET	QTY	P/N	DESCRIPTION
1	1	193022	STICKERTITE 1/4 X 3/4
2	1	291213	SPEAKERS (PAIR)
3	1	291214	ANTENNA
4	1	291605	INTERIOR LIGHT W/SWITCH
5	1	291834	RADIO SUPPORT BRKT
NS	1	344415	RADIO - STANDARD
NS	1	291933	HARNES, RADIO CQ-5335U STS 06
NS	1	293299	CAB DOME LIGHT GROUND
NS	1	293908	CAB ROOF HARNES 204SP
NS	1	294068	CAB WIPER MOTOR GROUND
11	1	342182	REAR A/C BLOWER MT WLD, CAB 94
NS	2	342333	NYL HOSE SLEEVE, 2.64ID X 12.00
NS	2	342343	NYL HOSE SLEEVE, 2.64ID X 6.00
14	2	342669	A/C DRAIN HOSE KEEPER

AIR CONDITIONER ASSEMBLY			
DET	QTY	P/N	DESCRIPTION
15	1	343331	RADIO BEZEL, CAB, BLK PLASIC 05
16	4	470087	3/8UNC HEX SERR FLANGE NUT
17	5	470121	1/4 UNC SERR FLG LOCK NUT
18	5	470122	1/4 UNC X 1/2 SERR FLG BOLT
19	1	470175	10-32 SERR FLANGE NUT
NS	1	470292	A/C INSULATION TAPE, 2" WIDE
21	4	472349	1/4 X 3/4 20THD-IN TEK TYPE
22	48	473966	#6 X3/4 PHIL FLTHD SHT MTL SCR
23	1	657461	A/C-HTR BLOWER SYS, DTS8 05
24	1	658313	ROOF SEAL, AIR COND 204,254,28
25	1	658327	VINYL HEAD LINER 99
26	4	900128	3/8UNC X 3/4 HEX BOLT
27	1	903883	10-32 X 1/2 PHIL PAN MACH SCR

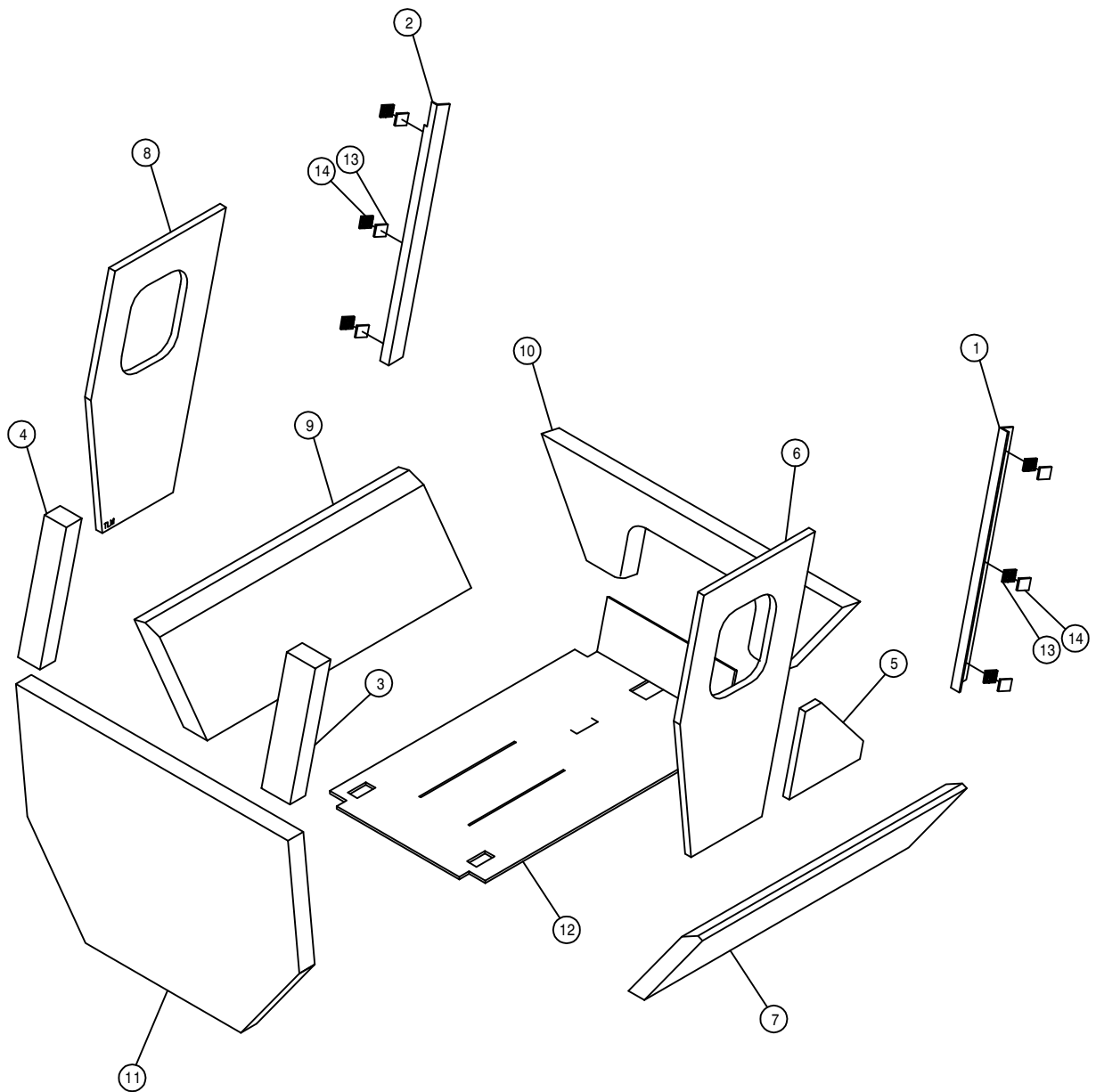

CAB FOAM

DET. QTY PART NO. DESCRIPTION

1	1	658301	VINYL POST COVER, RH FRONT	94
2	1	658302	VINYL POST COVER, LH FRONT	94
3	1	658303	VINYL POST COVER, RH REAR	94
4	1	658304	VINYL POST COVER, LH REAR	94
5	1	658305	VINYL SIDE PANEL, RH	94
6	1	658306	VINYL SIDE PANEL, RH UPPER	94
7	1	658307	VINYL SIDE PANEL, RH LOWER	94
8	1	658308	VINYL SIDE PANEL, LH UPPER	94
9	1	658309	VINYL SIDE PANEL, LH LOWER	94
10	1	658310	VINYL FRONT COVER PANEL	94
11	1	658311	VINYL REAR COVER PANEL	94
12	1	658316	CAB FLOORMAT, 284	97
13	6	471101	DUAL LOCK, 1.00 X 1.00	SJ3542
14	6	471100	DUAL LOCK, 1.00 X 1.00	SJ3541

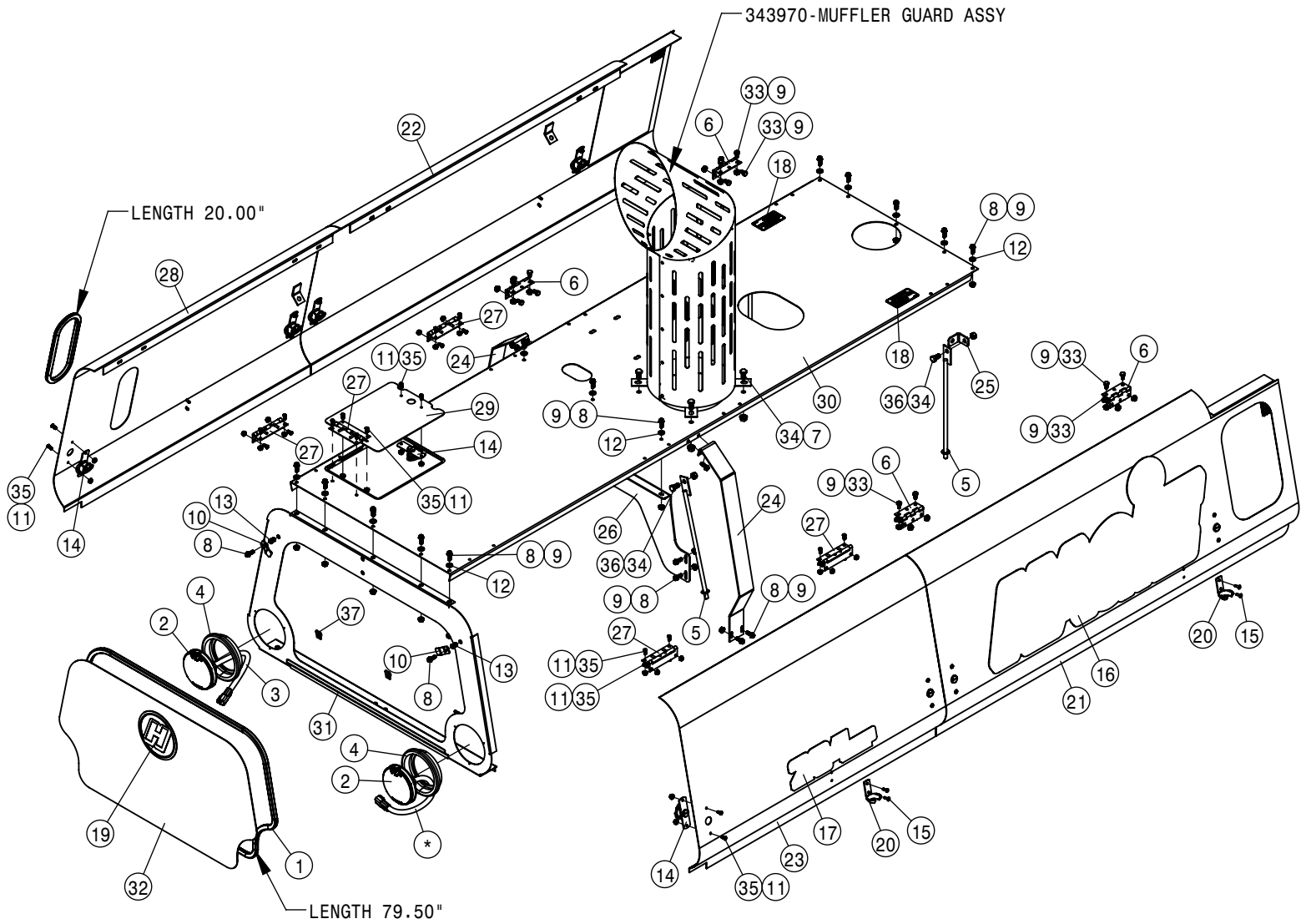

UPPER SHEET METAL ASSEMBLY			
DET	QTY	P/N	DESCRIPTION
1	2	193016	QUICKEDGE TRIM .060 TO .170
2	2	290201	RED LED STT 3 DIODE LAMP
3	2	290203	3-WIRE PIGTAIL FOR 290201 RED
4	2	290204	4" GROMMET FR 290200 & 290201
5	4	341356	ENGINE HOOD PROP WLD 8240 82
6	4	344106	HINGE 3 X 2 204 SP 2011
7	4	470087	3/8UNC HEX SERR FLANGE NUT
8	27	470118	1/4 UNC X 3/4 SER FLG BOLT
9	41	470121	1/4 UNC SERR FLG LOCK NUT
10	2	470151	UPPER REAR PANEL SCREEN CLIP
11	38	470175	10-32 SERR FLANGE NUT
12	13	470212	1/4 BONDED SEALING WASH, SS
13	2	470380N	1/4-20 NUTSERT .027-1.65 STL
14	9	470574	LATCH, SPRING COMPRESSION, LARGE
15	8	485053	POP RIVET 3/16 X 3/8
16	2	650778	HAGIE DECAL 33 X 14
17	2	650779	204SP DECAL 12.5 X 3.5
18	2	650851	DECAL, NOTICE, SHIELD PROTECT

UPPER SHEET METAL ASSEMBLY			
DET	QTY	P/N	DESCRIPTION
19	1	651008	DECAL - H-DOT FRONT GLASS 5.00"
20	4	656997	RUBBER HOOK BRACKET
21	1	660265	RH FRT ENG HOOD WLD, 204/SP '10
22	1	660266	LH FRT ENG HOOD WLD, 204/SP '10
23	1	660267	RH REAR HOOD WLD, 204/SP '10
24	2	660273	204 CE HOOD CENTER BRACE
25	2	660275	FRT HOOD PROP MR, 204/SP '10
26	1	660276	MULLION SUPPORT 204SP 11
27	5	660282	HINGE, 4" QUICK -DISCONNECT W/.218
28	1	660298	LH REAR HOOD WLD, 204
29	1	660654	FILTER ACCESS PLT
30	1	660655	MULLION, 204 CUMM WLD
31	1	660661	UPPER REAR PANEL WLD 204 T3
32	1	660786	UPPER REAR DOOR SCREEN WLD T3
33	16	900000	1/4UNC X 1/2 HEX BOLT
34	8	900128	3/8UNC X 3/4 HEX BOLT
35	38	903883	10-32 X 1/2 PHIL PAN MACH SCR
36	4	914004	3/8UNC HEX STOVER NUT
37	3	470386	1/4 -20 SPRING NUT LUG



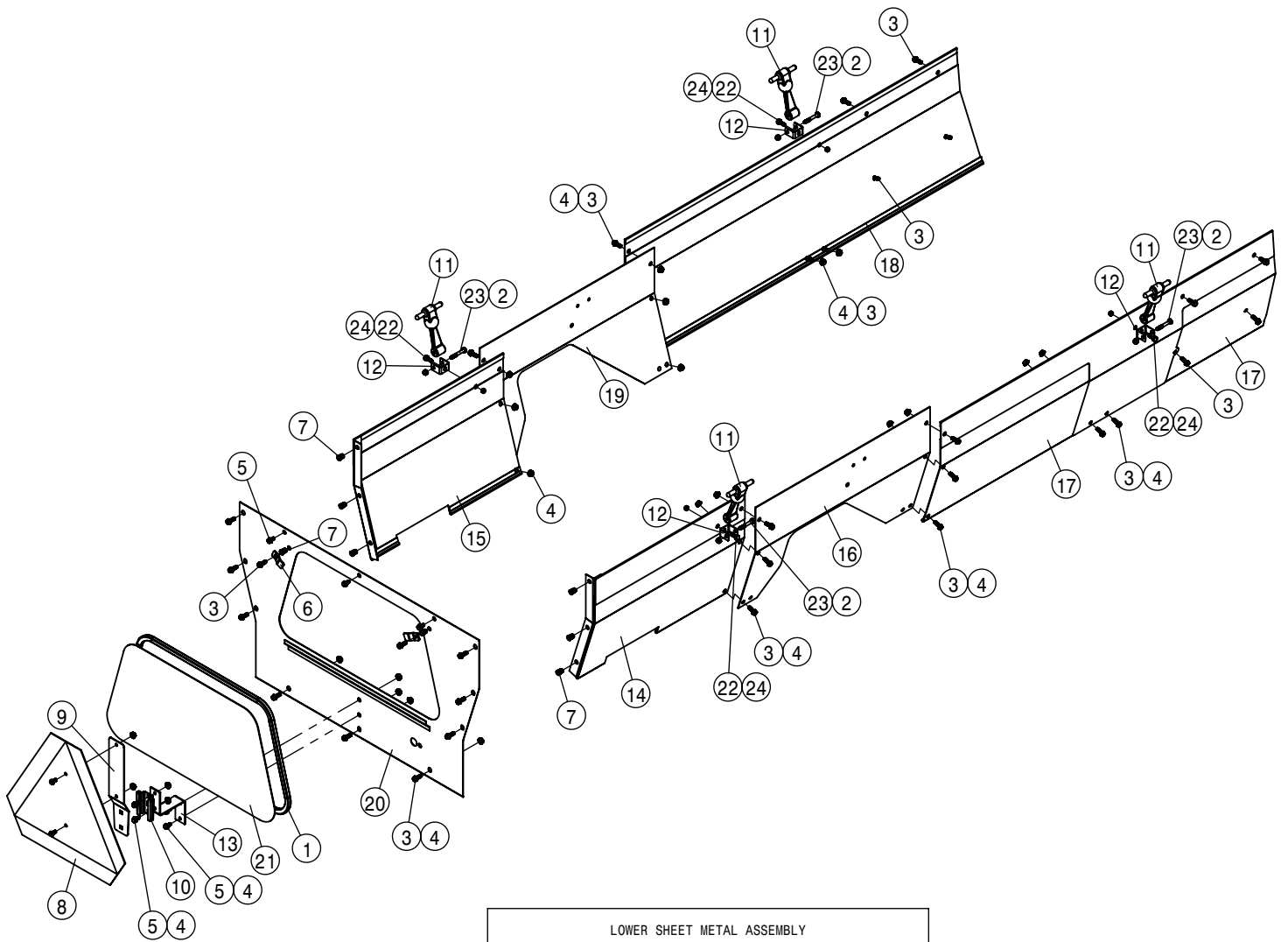

LOWER SHEET METAL ASSEMBLY			
DET	QTY	P/N	DESCRIPTION
1	1	193016	QUICKEDGE TRIM .060 TO .170
2	4	470089	1/4UNC HEX NYL-LOC NUT
3	35	470118	1/4 UNC X 3/4 SER FLG BOLT
4	25	470121	1/4 UNC SERR FLG LOCK NUT
5	7	470122	1/4 UNC X 1/2 SERR FLG BOLT
6	2	470151	UPPER REAR PANEL SCREEN CLIP
7	8	470380N	1/4-20 NUTSERT .027-1.65 STL
8	1	472249	SLOW MOVING VEHICLE SIGN
9	1	472250	SPADE MTG BRKT FOR 472249 SMV
10	1	472251	MTG SOCKET FOR 472249 SMV SIGN
11	4	656998	RUBBER HOOK
12	4	656999	RUBBER HOOK ANCHOR BRKT
13	1	659852	SMV SIGN MTG BRKT 8200 89
14	1	659889	RH REAR SIDE SCR N WLD 2XX 92
15	1	659890	LH REAR SIDE SCR N WLD 2XX 92
16	1	659895	RH LWR SIDE SHIELD 200/280 92
17	1	660080	RH FRT SIDE SCR N WLD 204 T3
18	1	660081	LH FRT SIDE SCR N WLD 204 T3
19	1	660281	LH LWR SIDE SHIELD 204SP '10
20	1	660717	LWR REAR PANEL WLD, 204 T3
21	1	660793	LWR BACK PANEL SCR N 204 COMMON
22	4	900002	1/4UNC x 3/4 HEX BOLT
23	4	900006	1/4UNC X 1 3/4 HEX BOLT
24	4	914000	1/4UNC HEX STOVER NUT

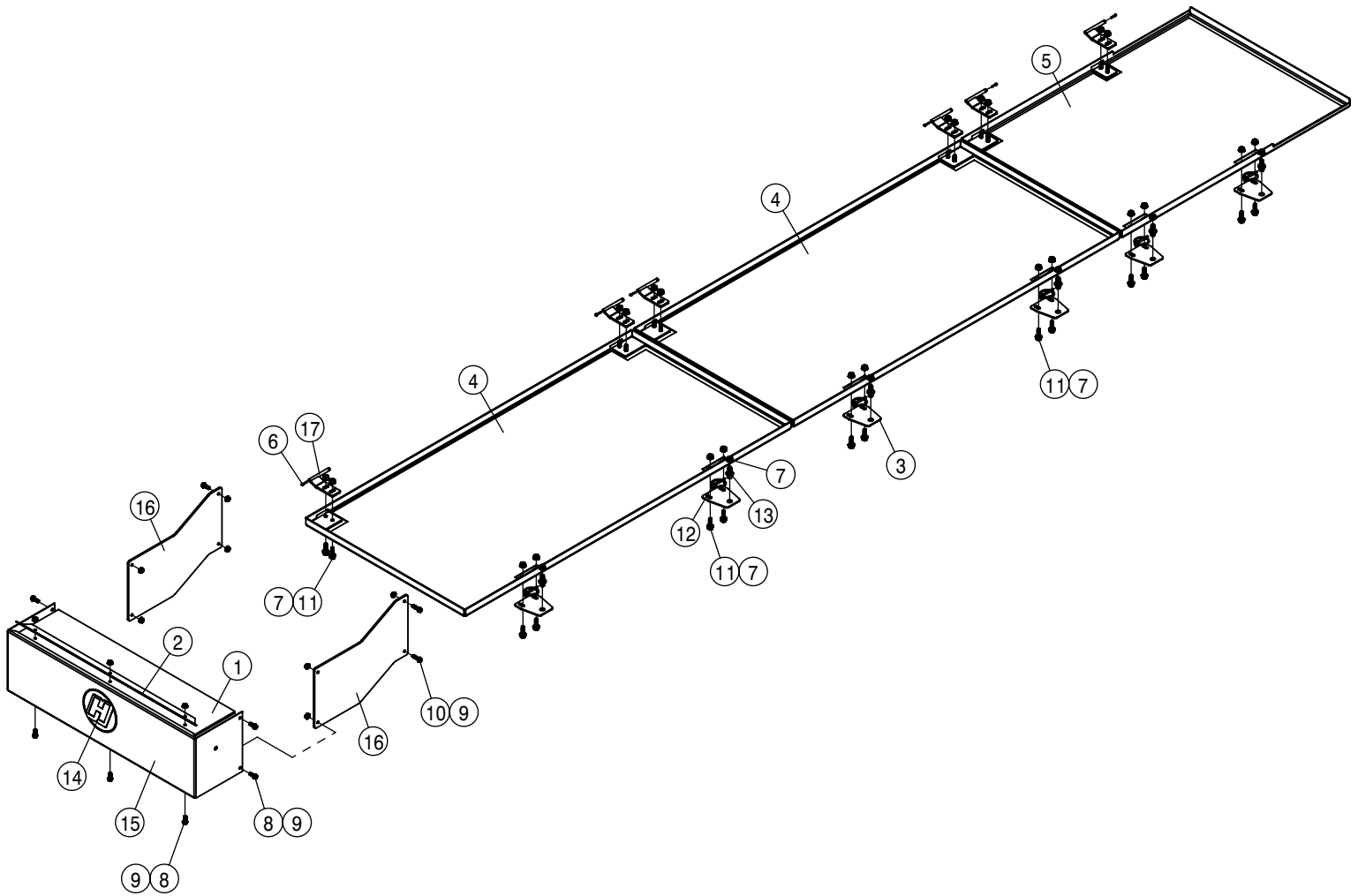

BELLY SHIELDS			
DET	QTY	P/N	DESCRIPTION
1	1	002229	REAR CUTTER TOP EXTEN FLAP
2	1	002230	REAR CUTTER TOP EXTEN FLAP KPR
3	6	362433	TAB BELLY PAN MNT
4	2	362434	BELLY PAN WLD FRT 204 T4F
5	1	362454	BELLY PAN WLD REAR 204 T3
6	6	470075	1/8 X 3/4 COTTER PIN
7	30	470113	5/16UNC SERR FLG LOCK NUT
8	9	470118	1/4 UNC X 3/4 SER FLG BOLT
9	11	470121	1/4 UNC SERR FLG LOCK NUT
10	2	470231	1/4UNC X 1" SERR FLG HEX BOLT
11	24	470234	5/16UNC X 1" SERR FLG HEX BOLT
12	6	470335	LINCHPIN, 3/16 X 1 1/4 GRIP
13	6	470520	HANGER PIN,3/8UNC x.437Dx.500L
14	1	651008	DECAL - H-DOT FRONT GLASS 5.00"
15	1	659853	200 LWR FRONT SHIELD 89
16	2	659997	LWR FRT SHIELD EXT 204 07
17	6	660578	HINGE - BELLY PAN, WLD

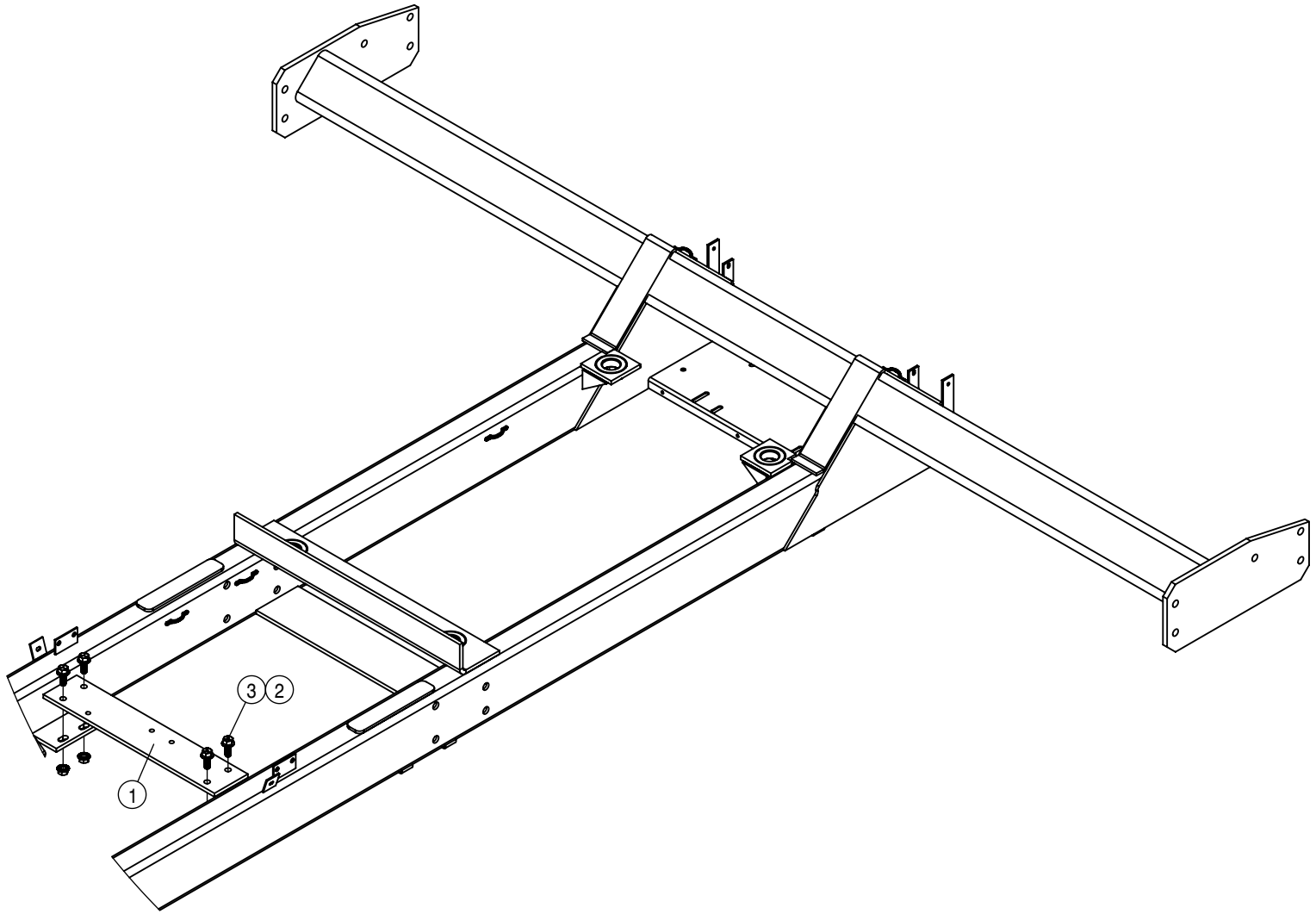

MAINFRAME ASSEMBLY			
DET	QTY	P/N	DESCRIPTION
1	1	341968	TIE PLT 250/280 CUMM 92
2	4	470360	1/2-13UNC HEX FLG NUT SER MC GR5
3	4	900517	1/2UNC X 1 1/4 HHSFB GR5 MC

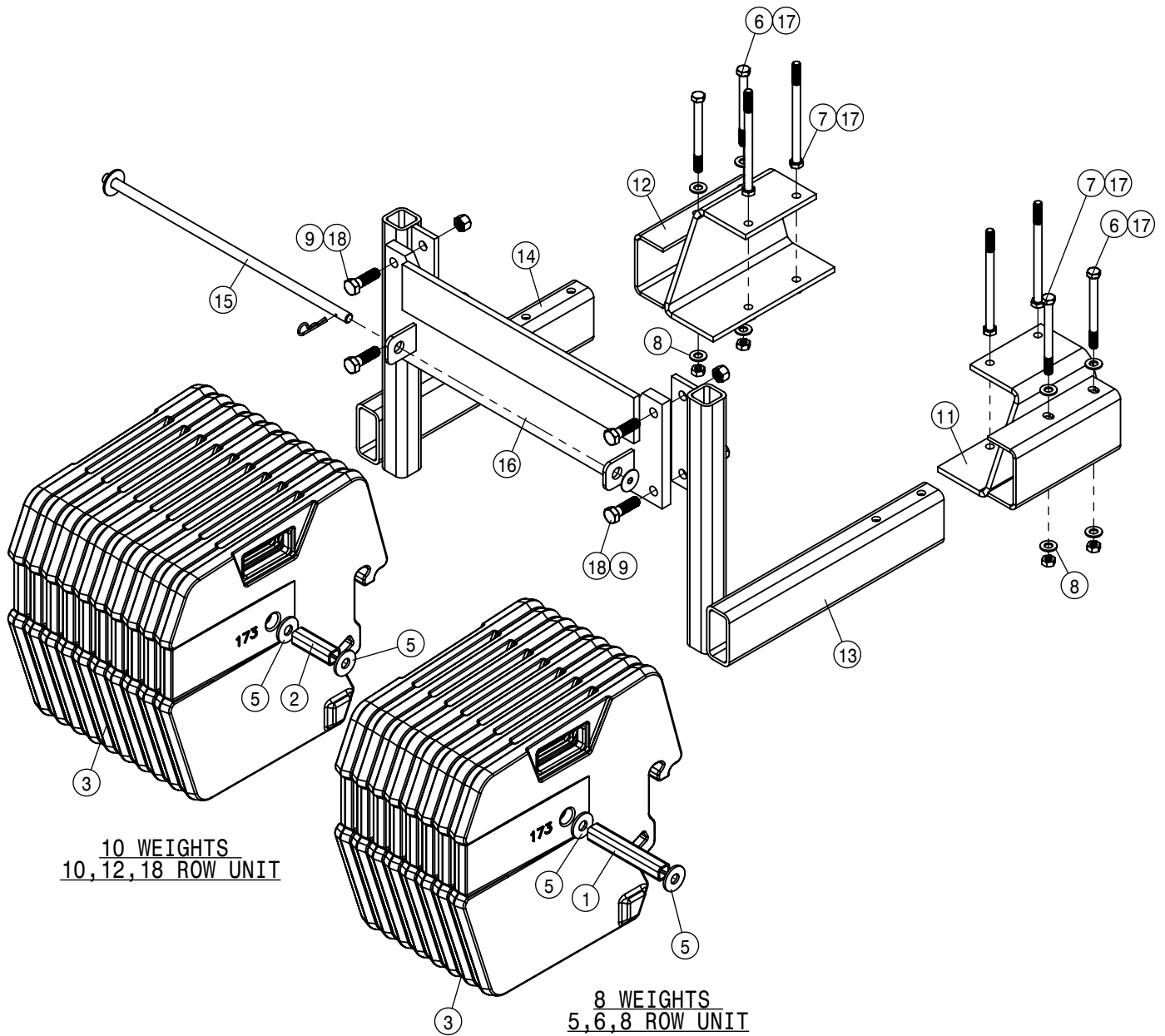

REAR WEIGHT BRACKET ASSEMBLY			
DET	QTY	P/N	DESCRIPTION
1	1	361944	1.000 SQ X 11GA X 6.25 C/L
2	1	361953	1.000 SQ X 11GA X 3.25 C/L
3	18	438604	IH WEIGHT, 173MAG 100 LB
4	1	470235	HAIR PIN, 1/8 DIA X 2 1/2 LG
5	4	483037N	5/8 REGULAR FLAT WASHER YZ
6	4	900277	1/2UNC X 5 1/2 HEX BOLT
7	4	900281	1/2UNC X 7 1/2 HEX BOLT
8	8	920004	1/2 SAE FLAT WASHER
9	4	914010	5/8UNC HEX STOVER NUT
10	1	920025	FENDER WASHER 1 1/2 MC
11	1	341980	RH REAR TOOL BAR MT WLD
12	1	341981	LH REAR TOOL BAR MT WLD
13	1	438575	RH WEIGHT MT BRKT WLD
14	1	438576	LH WEIGHT MT BRKT WLD
15	1	438648	CASE IH WEIGHT LOCK BOLT WLD
16	1	438660	IH 173MAG WEIGHT ADPT PLT WLD
17	8	914008	1/2 UNC HEX STOVER NUT
18	4	900335	5/8UNC X 2" HEX BOLT

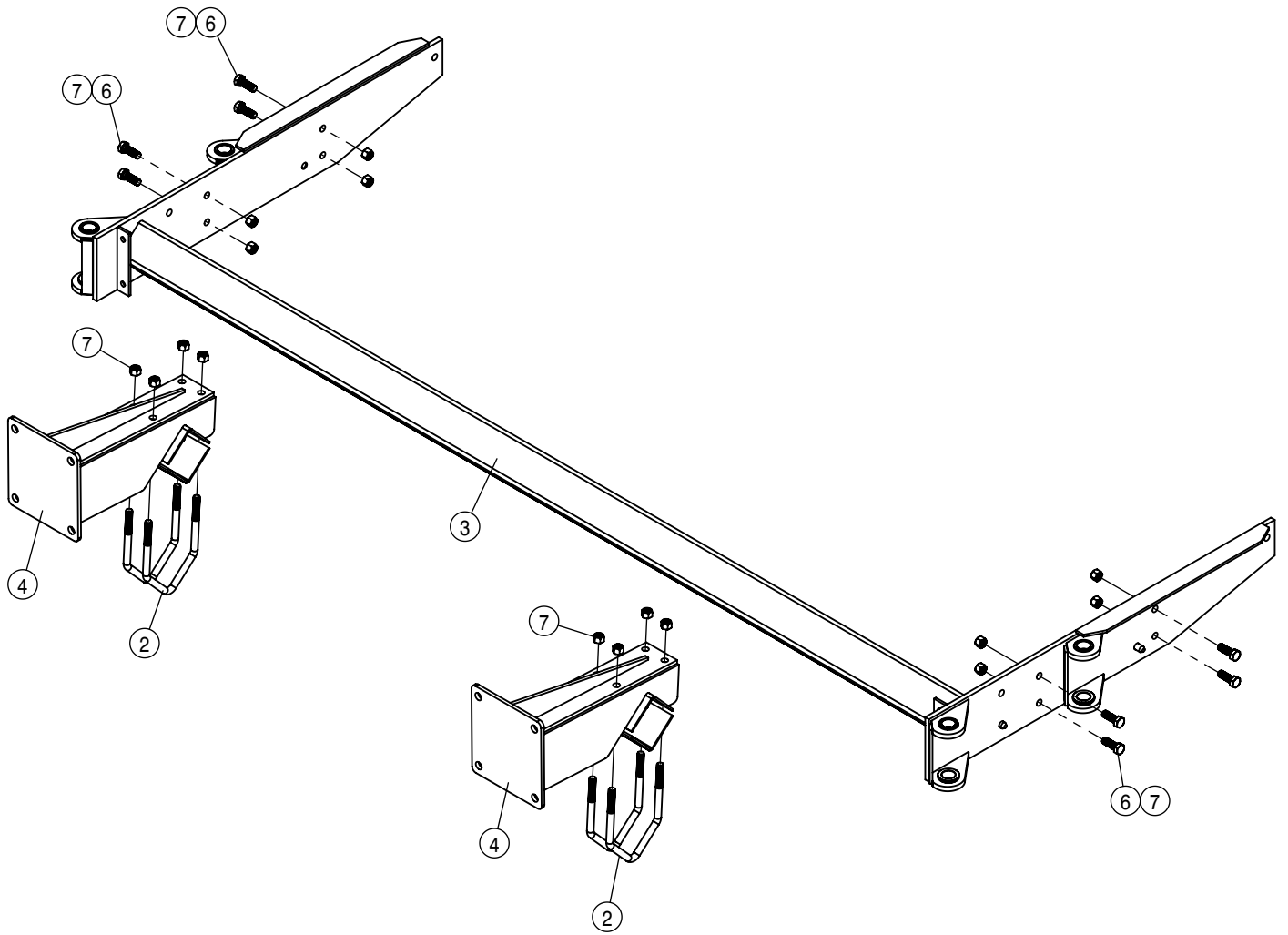

4-ROW, 2-LIFT, OUTRIGGER ASSEMBLY			
DET	QTY	P/N	DESCRIPTION
1	2	438292	TOOL BAR V-PLT WLD 8200 86
2	4	438293	5/8UNC X 6 1/4 CTR U-BOLT TRI
3	1	438530	204 TOOL BAR WLD, 12R 5/6L 96
4	2	438762	16"HOIST COL ADPTR WLD, 204 04
NS	1	438778	204SPW TOOL BAR WLD 08
6	8	900334	5/8UNC X 1 3/4 HEX BOLT
7	16	914010	5/8UNC HEX STOVER NUT

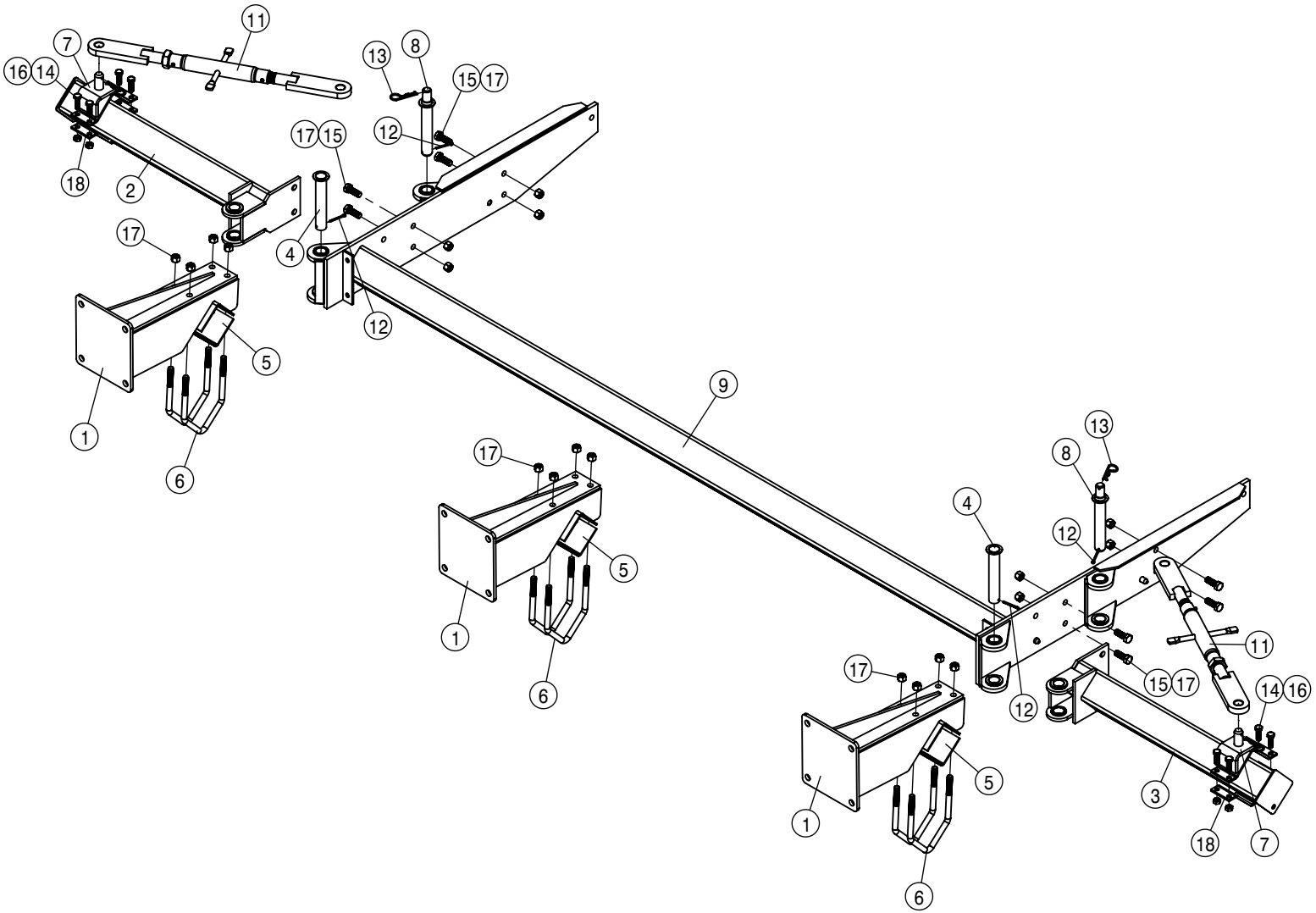

6-ROW, 3-LIFT, OUTRIGGER ASSEMBLY			
DET	QTY	P/N	DESCRIPTION
1	3	438762	16*HOIST COL ADPTR WLD, 204 04
2	1	438277	RH 32IN OUTGR WLD8200-850086
3	1	438282	LH 32IN OUTGR WLD8200-850086
4	2	438283	OUTGR PIVOT PIN WLD 8200 86
5	3	438292	TOOL BAR V-PLT WLD 8200 86
6	6	438293	5/8UNC X 6 1/4 CTR U-BOLT TRI
7	2	438397	STABILIZER PIN MT WLD 90
8	2	438474	STABILIZER MT PIN WLD 10-12R
9	1	438530	204 TOOL BAR WLD,12R 5/6L 96
NS	1	438778	204SPW TOOL BAR WLD 08
11	2	438785	OUTGR BINDER
12	4	470117	3/16 X 1 3/4 COTTER PIN
13	4	611016	HAIR PIN #6
14	8	900265	1/2UNC X 1 1/2 HEX BOLT
15	8	900334	5/8UNC X 1 3/4 HEX BOLT
16	8	914008	1/2 UNC HEX STOVER NUT
17	20	914010	5/8UNC HEX STOVER NUT
18	2	438324	75IN OUTGR BRACE CLAMP (PAINT)

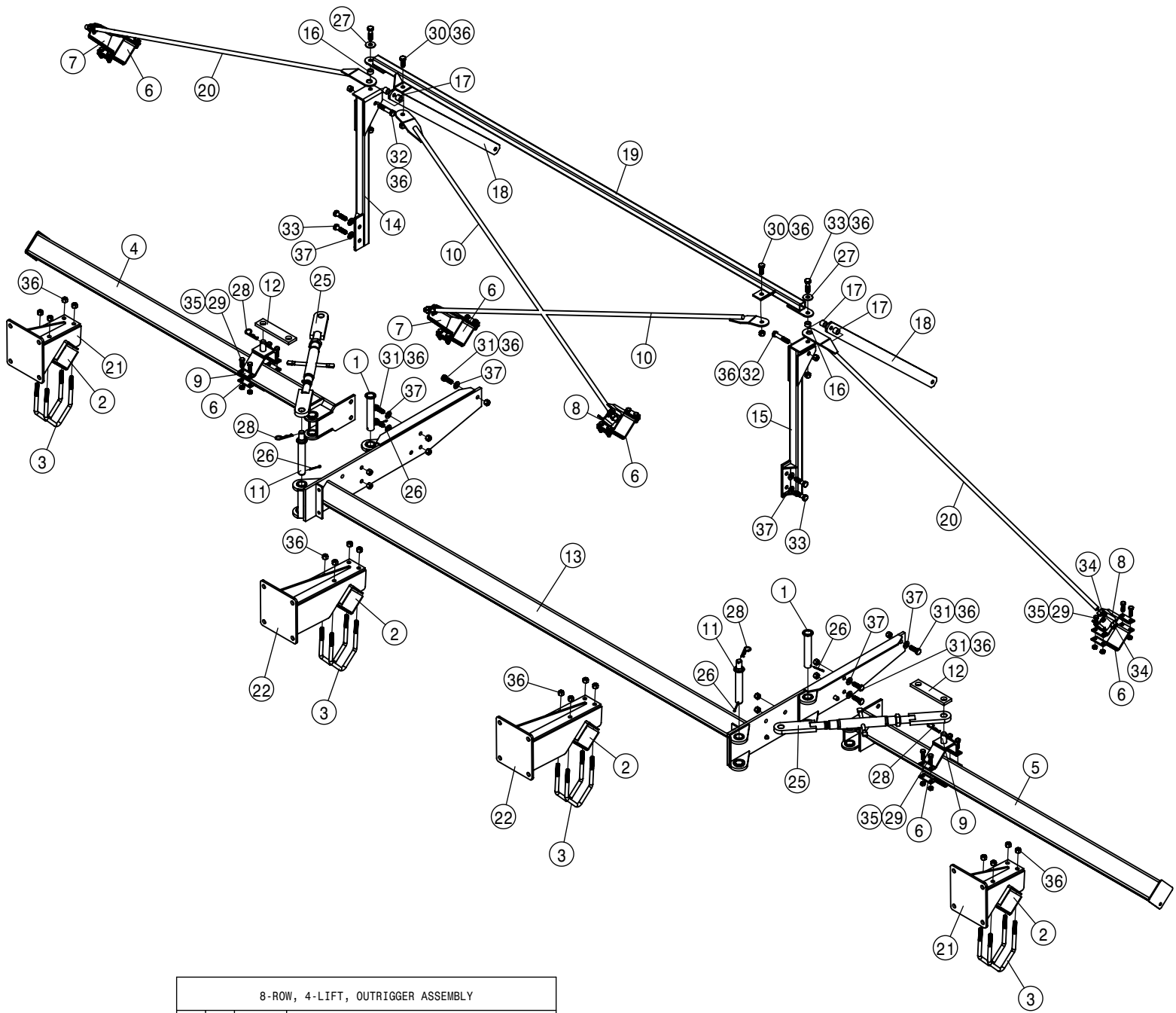

8-ROW, 4-LIFT, OUTRIGGER ASSEMBLY			
DET	QTY	P/N	DESCRIPTION
1	2	438283	OUTRGR PIVOT PIN WLD 8200 86
2	4	438292	TOOL BAR V-PLT WLD 8200 86
3	8	438293	5/8UNC X 6 1/4 CTR U-BOLT TRI
4	1	438307	RH 75IN OUTRGR WLD8200-850086
5	1	438309	LH 75IN OUTRGR WLD8200-850086
6	6	438324	75IN OUTRGR BRACE CLAMP (PAINT)
7	2	438362	RH OUTRGR CLAMP WLD 200 89
8	2	438363	LH OUTRGR CLAMP WLD 200 89
9	2	438397	STABILIZER PIN MT WLD 90
10	2	438469	OUTRGR TIE BAR WLD 200 10-12R
11	2	438474	STABILIZER MT PIN WLD 10-12R
12	2	438476	OUTRGR TRANSPORT BAR 10-12R
13	1	438530	204 TOOL BAR WLD,12R 5/6L 96
14	1	438536	RH OUTRGR SUPP POST WLD10/12R
15	1	438537	LH OUTRGR SUPP POST WLD10/12R
16	2	438541	BUSH,1.00 OD-.656 ID-.53 LG
17	4	438542	BUSH 1.00 OD X .656 ID X .78
18	2	438543	OUTRGR SUPP BRACE,10/12R 96
19	1	438672	204 CENTER TIE TUBE WLD 2001
20	2	438676	OUTRGR SUPP ROD WLD 72" 8R 01

8-ROW, 4-LIFT, OUTRIGGER ASSEMBLY			
DET	QTY	P/N	DESCRIPTION
21	2	438757	8" HOIST COL ADPTR WLD, 204 04
22	2	438762	16"HOIST COL ADPTR WLD, 204 04
NS	1	438778	204SPW TOOL BAR WLD 08
NS	1	438780	204SPW CENTER TIE TUBE WLD 08
25	2	438785	OUTRGR BINDER
26	4	470117	3/16 X 1 3/4 COTTER PIN
27	2	483037	5/8 REGULAR FLAT WASHER
28	4	611016	HAIR PIN #6
29	24	900265	1/2UNC X 1 1/2 HEX BOLT
30	2	900333	5/8UNC X 1 1/2 HEX BOLT
31	6	900334	5/8UNC X 1 3/4 HEX BOLT
32	2	900339	5/8UNC X 3 1/4 HEX BOLT
33	6	900352	5/8UNC X 2 1/4 HEX BOLT
34	8	910012	3/4UNC HEX NUT
35	24	914008	1/2 UNC HEX STOVER NUT
36	32	914010	5/8UNC HEX STOVER NUT
37	10	920005N	5/8 SAE FLAT WASHER

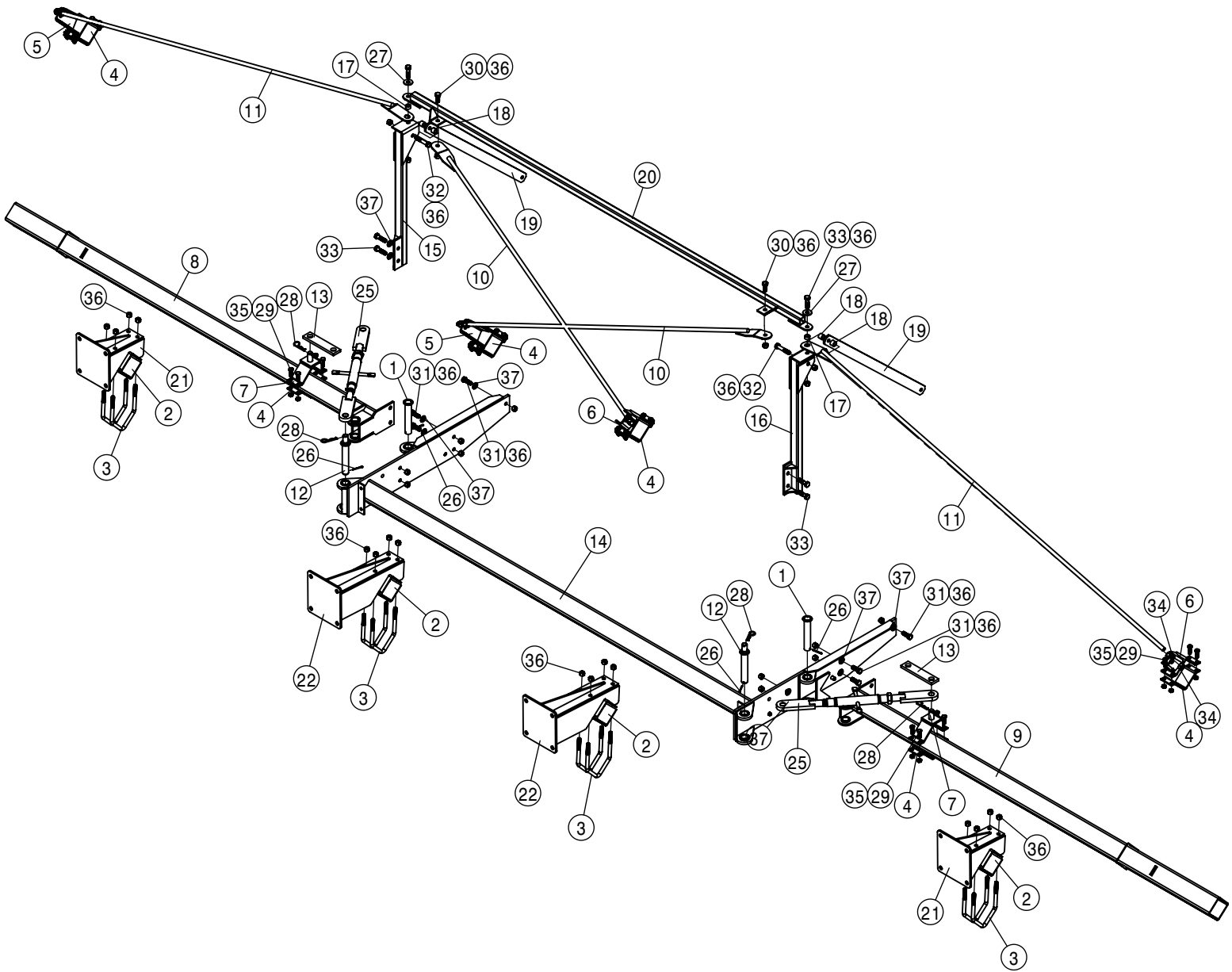

10-ROW, 4-LIFT, OUTRIGGER ASSEMBLY			
DET	QTY	P/N	DESCRIPTION
1	2	438283	OUTRGR PIVOT PIN WLD 8200 86
2	4	438292	TOOL BAR V-PLT WLD 8200 86
3	8	438293	5/8UNC X 6 1/4 CTR U-BOLT TRI
4	6	438324	75IN OUTRGR BRACE CLAMP (PAINT)
5	2	438362	RH OUTRGR CLAMP WLD 200 89
6	2	438363	LH OUTRGR CLAMP WLD 200 89
7	2	438397	STABILIZER PIN MT WLD 90
8	1	438458	RH 101IN OUTRGR WLD 10-12R 92
9	1	438459	LH 101IN OUTRGR WLD 10-12R 92
10	2	438469	OUTRGR TIE BAR WLD 200 10-12R
11	2	438471	OUTRGR SUPP ROD WLD 10-12R
12	2	438474	STABILIZER MT PIN WLD 10-12R
13	2	438476	OUTRGR TRANSPORT BAR 10-12R
14	1	438530	204 TOOL BAR WLD, 12R 5/6L 96
15	1	438536	RH OUTRGR SUPP POST WLD10/12R
16	1	438537	LH OUTRGR SUPP POST WLD10/12R
17	2	438541	BUSH, 1.00 OD- .656 ID- .53 LG
18	4	438542	BUSH 1.00 OD X .656 ID X .78
19	2	438543	OUTRGR SUPP BRACE, 10/12R 96

10-ROW, 4-LIFT, OUTRIGGER ASSEMBLY			
DET	QTY	P/N	DESCRIPTION
20	1	438672	204 CENTER TIE TUBE WLD 2001
21	2	438757	8" HOIST COL ADPTR WLD, 204 04
22	2	438762	16"HOIST COL ADPTR WLD, 204 04
NS	1	438778	204SPW TOOL BAR WLD 08
NS	1	438780	204SPW CENTER TIE TUBE WLD 08
25	2	438785	OUTRGR BINDER
26	4	470117	3/16 X 1 3/4 COTTER PIN
27	2	483037	5/8 REGULAR FLAT WASHER
28	4	611016	HAIR PIN #6
29	24	900265	1/2UNC X 1 1/2 HEX BOLT
30	2	900333	5/8UNC X 1 1/2 HEX BOLT
31	6	900334	5/8UNC X 1 3/4 HEX BOLT
32	2	900339	5/8UNC X 3 1/4 HEX BOLT
33	6	900352	5/8UNC X 2 1/4 HEX BOLT
34	8	910012	3/4UNC HEX NUT
35	24	914008	1/2 UNC HEX STOVER NUT
36	32	914010	5/8UNC HEX STOVER NUT
37	10	920005N	5/8 SAE FLAT WASHER



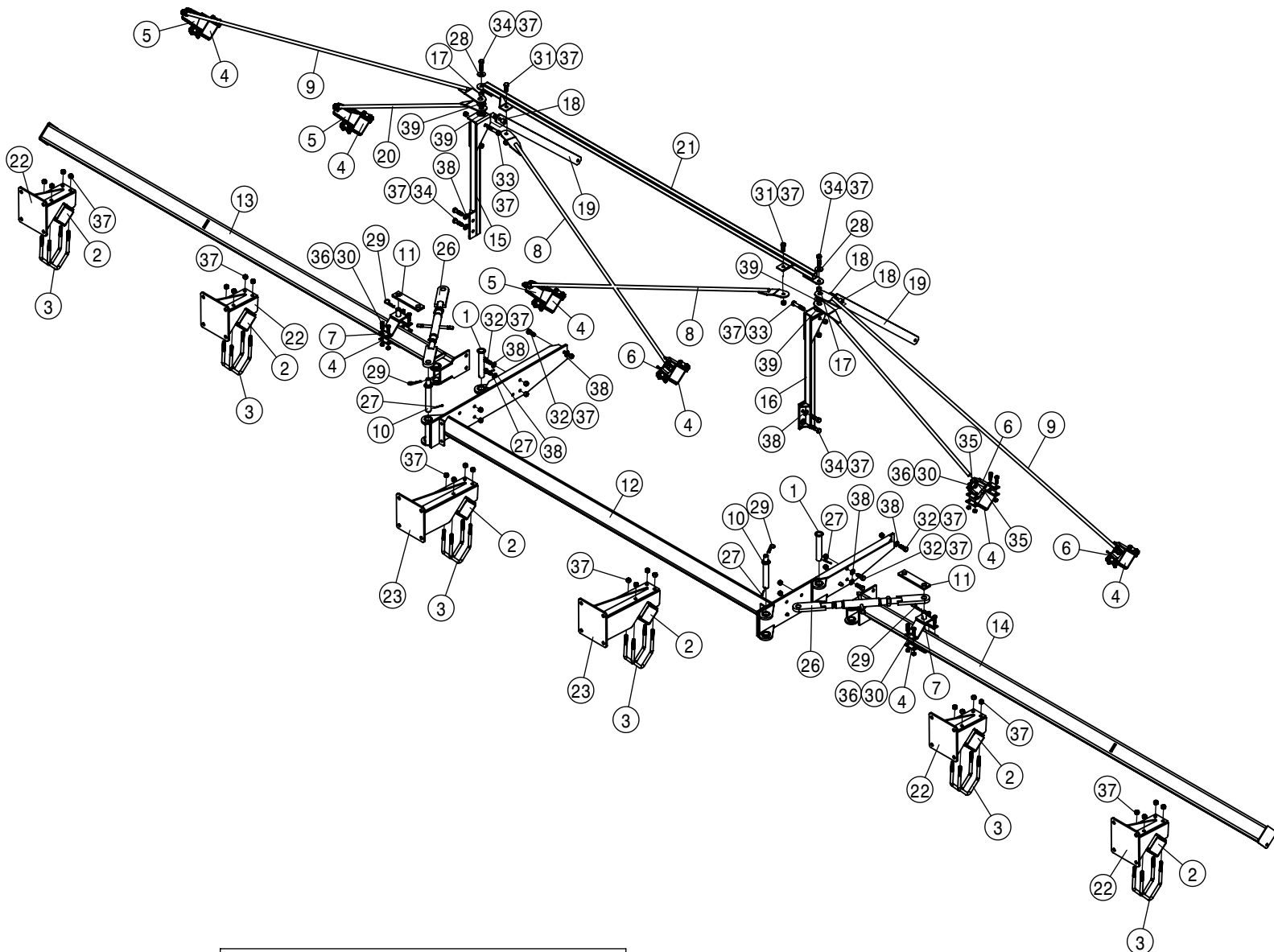

12-ROW, 6-LIFT, OUTRIGGER ASSEMBLY			
DET	QTY	P/N	DESCRIPTION
1	2	438283	OUTRGR PIVOT PIN WLD 8200 86
2	6	438292	TOOL BAR V-PLT WLD 8200 86
3	12	438293	5/8UNC X 6 1/4 CTR U-BOLT TRI
4	8	438324	75IN OUTRGR BRACE CLAMP (PAINT)
5	3	438362	RH OUTRGR CLAMP WLD 200 89
6	3	438363	LH OUTRGR CLAMP WLD 200 89
7	2	438397	STABILIZER PIN MT WLD 90
8	2	438469	OUTRGR TIE BAR WLD 200 10-12R
9	2	438471	OUTRGR SUPP ROD WLD 10-12R
10	2	438474	STABILIZER MT PIN WLD 10-12R
11	2	438476	OUTRGR TRANSPORT BAR 10-12R
12	1	438530	204 TOOL BAR WLD,12R 5/6L 96
13	1	438533	RH 133" OUTRGR WLD, 10/12R 96
14	1	438534	LH 133" OUTRGR WLD, 10/12R 96
15	1	438536	RH OUTRGR SUPP POST WLD10/12R
16	1	438537	LH OUTRGR SUPP POST WLD10/12R
17	2	438541	BUSH,1.00 OD- .656 ID- .53 LG
18	4	438542	BUSH 1.00 OD X .656 ID X .78
19	2	438543	OUTRGR SUPP BRACE,10/12R 96
20	2	438544	OUTRGR SUPP ROD WLD 50"10/12

12-ROW, 6-LIFT, OUTRIGGER ASSEMBLY			
DET	QTY	P/N	DESCRIPTION
21	1	438672	204 CENTER TIE TUBE WLD 2001
22	4	438757	8" HOIST COL ADPTR WLD, 204 04
23	2	438762	16"HOIST COL ADPTR WLD, 204 04
NS	1	438778	204SPW TOOL BAR WLD 08
NS	1	438780	204SPW CENTER TIE TUBE WLD 08
26	2	438785	OUTRGR BINDER
27	4	470117	3/16 X 1 3/4 COTTER PIN
28	2	483037	5/8 REGULAR FLAT WASHER
29	4	611016	HAIR PIN #6
30	32	900265	1/2UNC X 1 1/2 HEX BOLT
31	2	900333	5/8UNC X 1 1/2 HEX BOLT
32	6	900334	5/8UNC X 1 3/4 HEX BOLT
33	2	900339	5/8UNC X 3 1/4 HEX BOLT
34	6	900352	5/8UNC X 2 1/4 HEX BOLT
35	12	910012	3/4UNC HEX NUT
36	32	914008	1/2 UNC HEX STOVER NUT
37	40	914010	5/8UNC HEX STOVER NUT
38	10	920005N	5/8 SAE FLAT WASHER
39	4	920008	1" SAE FLAT WASHER

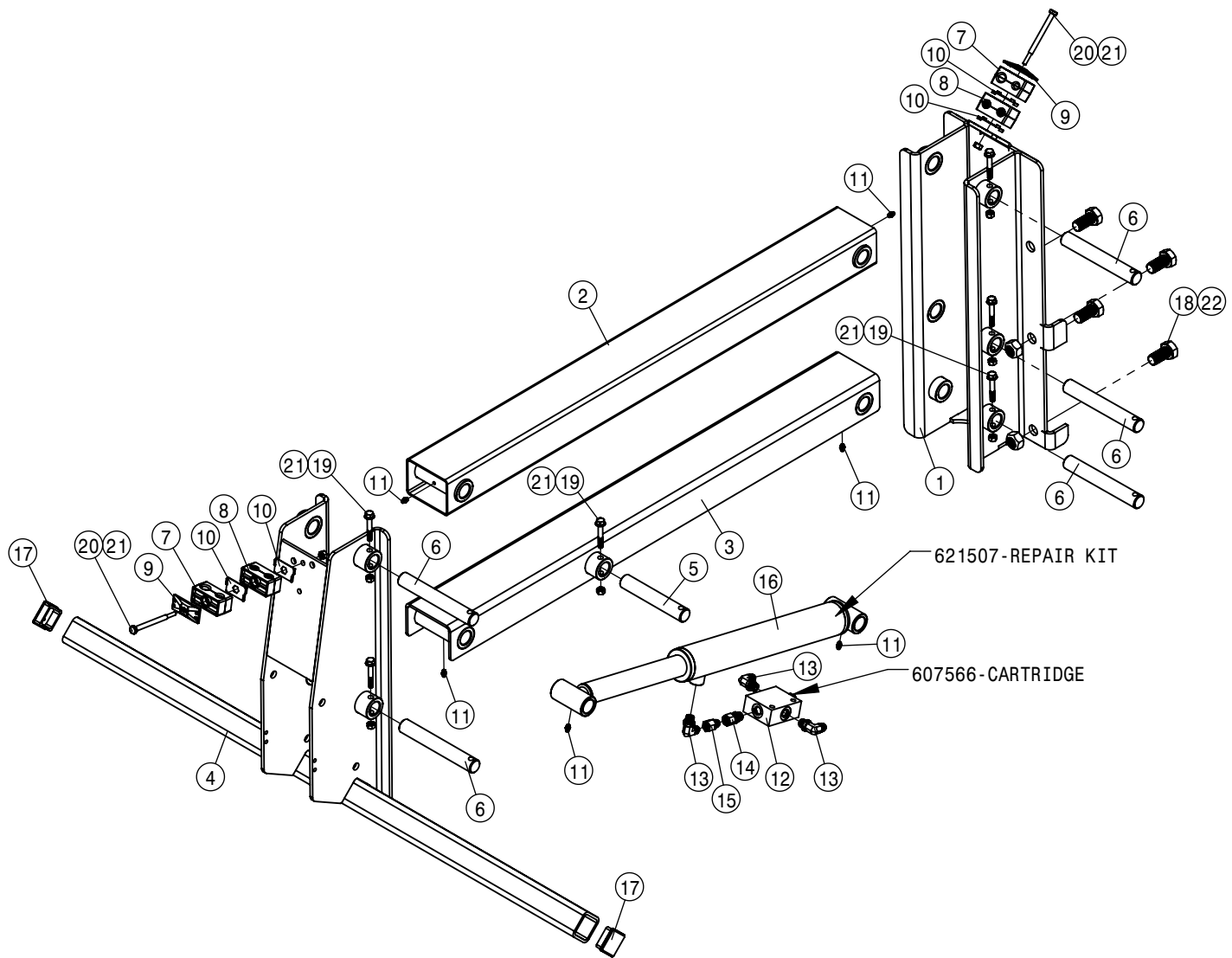

2-HEAD LIFT ASSEMBLY			
DET	QTY	P/N	DESCRIPTION
1	1	439136	TOOLBAR MT BRKT WLD, STSC 03
2	1	439143	UPPER LIFTARM WLD,STS COMBO 03
3	1	439146	LWR LIFTARM WLD, STS COMBO 03
4	1	439151	50" HEAD TOOLBAR WLD,STSC 03
5	1	439156	LWR CYL MT PIN, STS COMBO 03
6	5	439158	LIFT ARM PIVOT PIN, STSC 03
7	2	470270	TUBE CLAMP BODY, .530-.680
8	2	470274	TUBE CLAMP BODY, .750-.750
9	2	470276	CLAMP COVER PLATE,SNGL, 2.55LG
10	4	470281	STACK BOLT SAFETY LOCK PLATE
11	6	471005	GREASE ZERK, 1/4-28 X 1/2
12	1	607565	CHECK VLV,PILOT TO OPEN, SUN
13	3	618119	9/16MJIC-90-9/16MOR LBO
14	1	618668	9/16FJIC SWIV-9/16MOR ADPTR
15	1	618732	9/16JIC .031 ORIFICE ADPTR
16	1	621564	DETA LIFT CYL,2.00 X 11.00STS
17	2	629773	CAPLUGS 1 3/4"SQ PLUG,BLK POLY
18	4	900401	3/4UNC X 1 1/2 HEX BOLT
19	6	900493	5/16UNC X 2 HHSFB SS
20	2	900499	5/16UNC X 4 HHCS SS
21	8	914002	5/16UNC HEX STOVER NUT
22	4	914012	3/4UNC HEX STOVER NUT

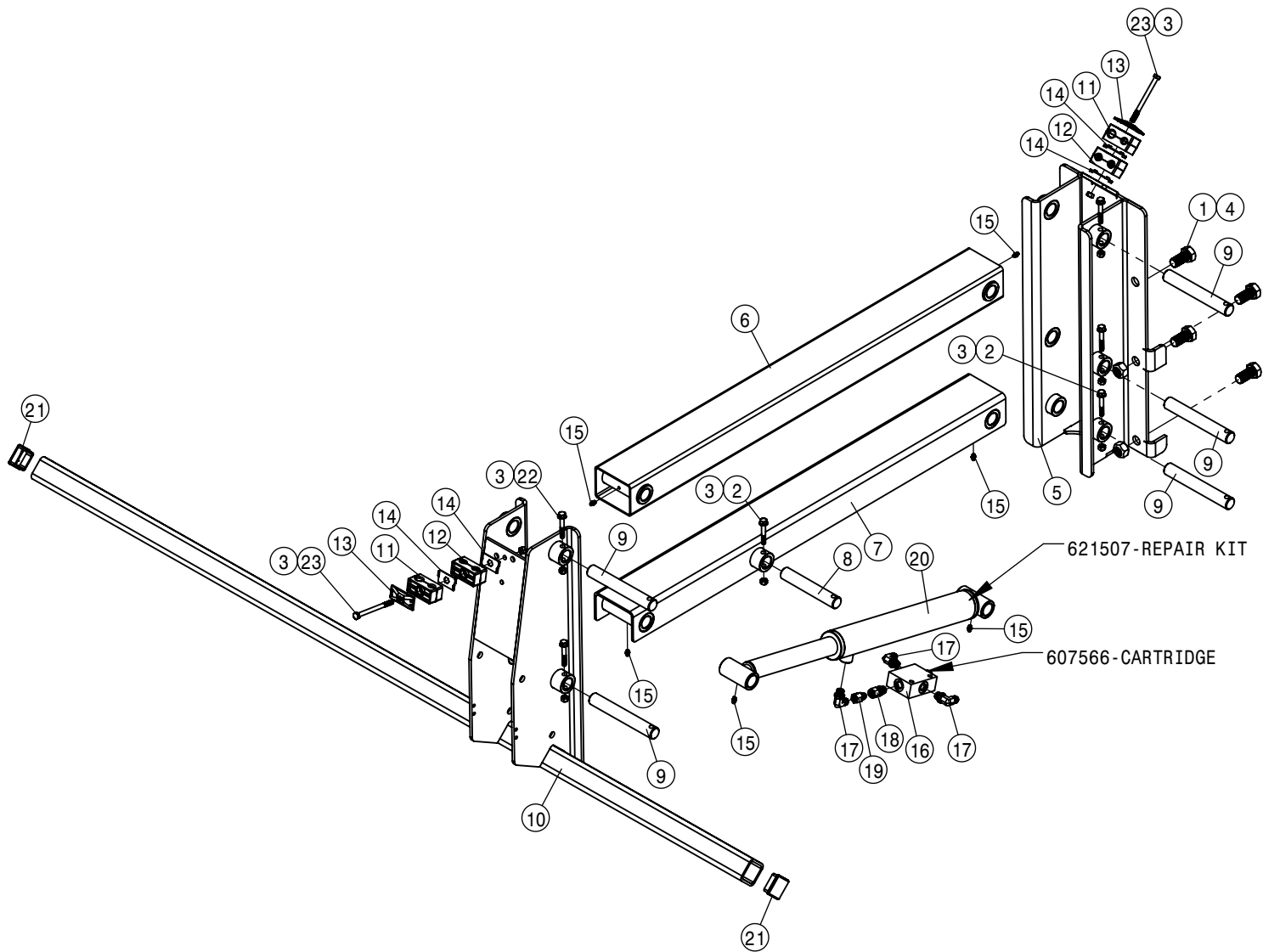

RIGHT 3-HEAD LIFT ASSEMBLY			
DET	QTY	P/N	DESCRIPTION
1	4	900401	3/4UNC X 1 1/2 HEX BOLT
2	2	900493	5/16UNC X 2 HHSFB SS
3	8	914002	5/16UNC HEX STOVER NUT
4	4	914012	3/4UNC HEX STOVER NUT
5	1	439136	TOOLBAR MT BRKT WLD, STSC 03
6	1	439143	UPPER LIFTARM WLD, STS COMBO 03
7	1	439146	LWR LIFTARM WLD, STS COMBO 03
8	1	439156	LWR CYL MT PIN, STS COMBO 03
9	5	439158	LIFT ARM PIVOT PIN, STSC 03
10	1	439163	80°RH HEAD TOOLBAR WLD, STSC 03
11	2	470270	TUBE CLAMP BODY, .530-.680
12	2	470274	TUBE CLAMP BODY, .750-.750
13	2	470276	CLAMP COVER PLATE, SNGL, 2.55LG
14	4	470281	STACK BOLT SAFETY LOCK PLATE
15	6	471005	GREASE ZERK, 1/4-28 X 1/2
16	1	607565	CHECK VLV, PILOT TO OPEN, SUN
17	3	618119	9/16MJIC-90-9/16MOR LBO
18	1	618668	9/16FJIC SWIV-9/16MOR ADPTR
19	1	618732	9/16JIC .031 ORIFICE ADPTR
20	1	621564	DETA5 LIFT CYL, 2.00 X 11.00STS
21	2	629773	CAPPLUGS 1 3/4" SQ PLUG, BLK POLY
22	4	900069N	5/16UNC X 2" SERR FLG BOLT SS
23	2	900076	5/16UNC X 4" HEX BOLT

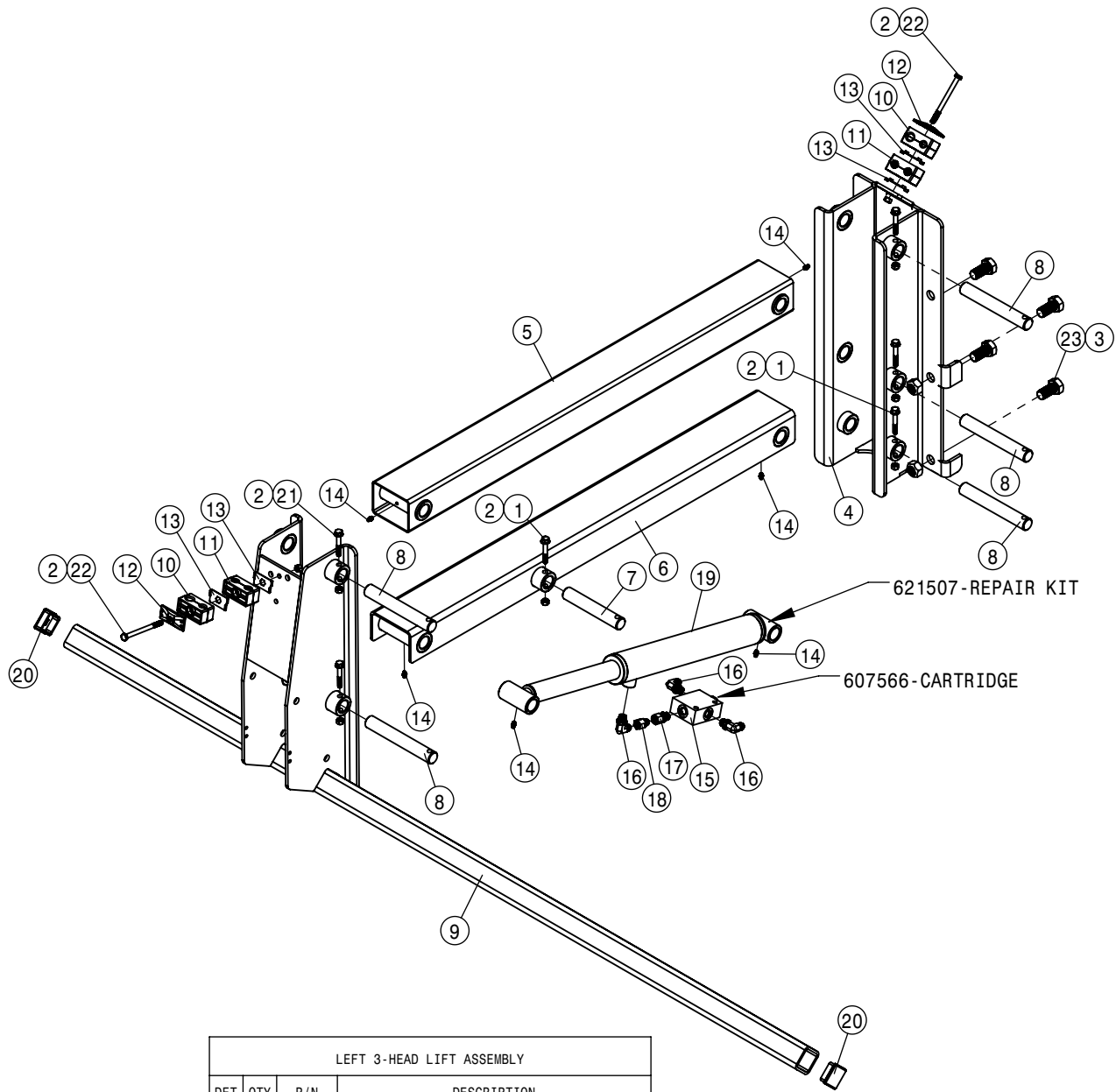

LEFT 3-HEAD LIFT ASSEMBLY			
DET	QTY	P/N	DESCRIPTION
1	2	900493	5/16UNC X 2 HHSFB SS
2	8	914002	5/16UNC HEX STOVER NUT
3	4	914012	3/4UNC HEX STOVER NUT
4	1	439136	TOOLBAR MT BRKT WLD, STSC 03
5	1	439143	UPPER LIFTARM WLD,STS COMBO 03
6	1	439146	LWR LIFTARM WLD, STS COMBO 03
7	1	439156	LWR CYL MT PIN, STS COMBO 03
8	5	439158	LIFT ARM PIVOT PIN, STSC 03
9	1	439164	80"LH HEAD TOOLBAR WLD,STSC 03
10	2	470270	TUBE CLAMP BODY, .530-.680
11	2	470274	TUBE CLAMP BODY, .750-.750
12	2	470276	CLAMP COVER PLATE,SNGL, 2.55LG
13	4	470281	STACK BOLT SAFETY LOCK PLATE
14	6	471005	GREASE ZERK, 1/4-28 X 1/2
15	1	607565	CHECK VLV,PILOT TO OPEN, SUN
16	3	618119	9/16MJIC-90-9/16MOR LBO
17	1	618668	9/16FJIC SWIV-9/16MOR ADPTR
18	1	618732	9/16JIC .031 ORIFICE ADPTR
19	1	621564	DETA5 LIFT CYL,2.00 X 11.00STS
20	2	629773	CAPPLUGS 1 3/4"SQ PLUG,BLK POLY
21	4	900069N	5/16UNC X 2" SERR FLG BOLT SS
22	2	900076	5/16UNC X 4" HEX BOLT
23	4	900401	3/4UNC X 1 1/2 HEX BOLT

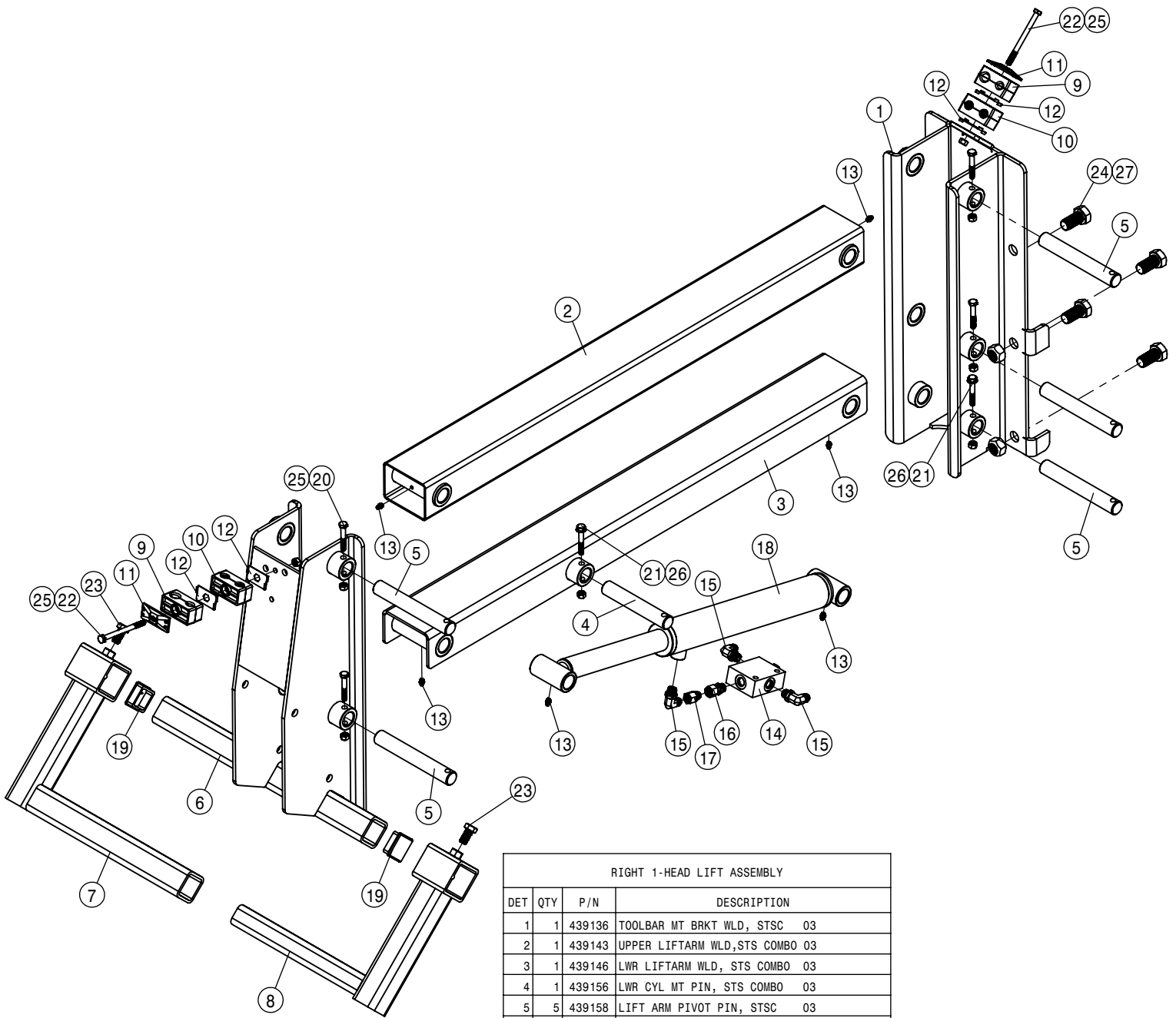

RIGHT 1-HEAD LIFT ASSEMBLY

DET	QTY	P/N	DESCRIPTION
1	1	439136	TOOLBAR MT BRKT WLD, STSC 03
2	1	439143	UPPER LIFTARM WLD, STS COMBO 03
3	1	439146	LWR LIFTARM WLD, STS COMBO 03
4	1	439156	LWR CYL MT PIN, STS COMBO 03
5	5	439158	LIFT ARM PIVOT PIN, STSC 03
6	1	441002	60CM RH TOOLBAR WLD 204SP'12
7	1	441003	RH 1-HEAD MT WLD 204SP 12
8	1	441004	LH 1-HEAD MT WLD 204SP 12
9	2	470270	TUBE CLAMP BODY, .530-.680
10	2	470274	TUBE CLAMP BODY, .750-.750
11	2	470276	CLAMP COVER PLATE, SNGL, 2.55LG
12	4	470281	STACK BOLT SAFETY LOCK PLATE
13	6	471005	GREASE ZERK, 1/4-28 X 1/2
14	1	607565	CHECK VLV, PILOT TO OPEN, SUN
15	3	618119	9/16MJIC-90-9/16MOR LBO
16	1	618668	9/16FJIC SWIV-9/16MOR ADPTR
17	1	618732	9/16JIC .031 ORIFICE ADPTR
18	1	621564	DETA5 LIFT CYL, 2.00 X 11.00STS
19	2	629773	CAPLUGS 1 3/4" SQ PLUG, BLK POLY
20	4	900069	5/16UNC X 2" HEX BOLT
21	2	900069N	5/16UNC X 2" SERR FLG BOLT SS
22	2	900076	5/16UNC X 4" HEX BOLT
23	2	900263	1/2UNC X 1" HEX BOLT
24	4	900401	3/4UNC X 1 1/2 HEX BOLT
25	6	914002	5/16UNC HEX STOVER NUT
26	2	914002N	5/16UNC HEX STOVER NUT YZ
27	4	914012	3/4UNC HEX STOVER NUT

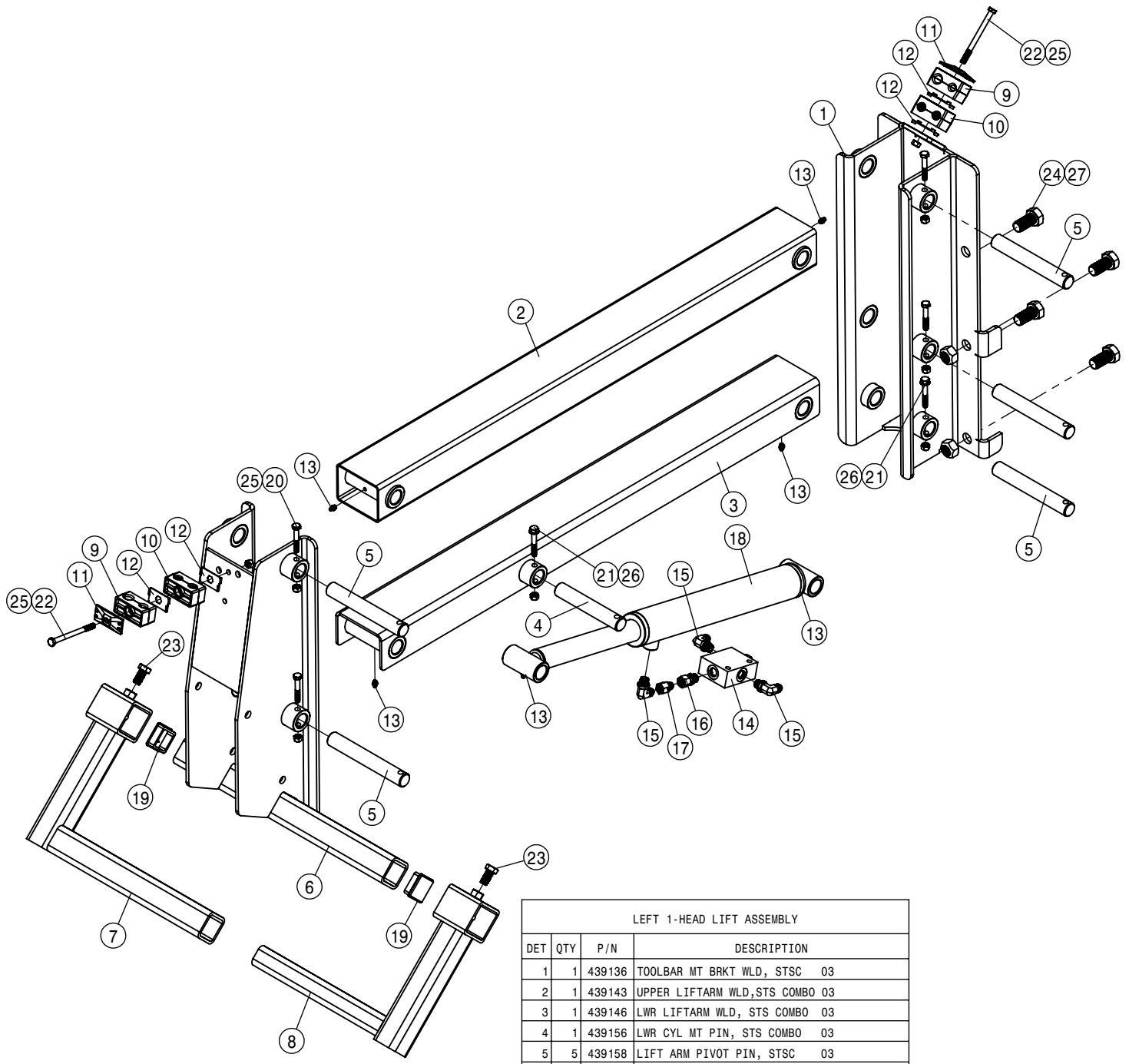

LEFT 1-HEAD LIFT ASSEMBLY			
DET	QTY	P/N	DESCRIPTION
1	1	439136	TOOLBAR MT BRKT WLD, STSC 03
2	1	439143	UPPER LIFTARM WLD,STS COMBO 03
3	1	439146	LWR LIFTARM WLD, STS COMBO 03
4	1	439156	LWR CYL MT PIN, STS COMBO 03
5	5	439158	LIFT ARM PIVOT PIN, STSC 03
6	1	441000	60CM LH TOOLBAR WLD 204SP'12
7	1	441003	RH 1-HEAD MT WLD 204SP 12
8	1	441004	LH 1-HEAD MT WLD 204SP 12
9	2	470270	TUBE CLAMP BODY, .530-.680
10	2	470274	TUBE CLAMP BODY, .750-.750
11	2	470276	CLAMP COVER PLATE,SNGL, 2.55LG
12	4	470281	STACK BOLT SAFETY LOCK PLATE
13	6	471005	GREASE ZERK, 1/4-28 X 1/2
14	1	607565	CHECK VLV,PILOT TO OPEN, SUN
15	3	618119	9/16MJIC-90-9/16MOR LBO
16	1	618668	9/16FJIC SWIV-9/16MOR ADPTR
17	1	618732	9/16JIC .031 ORIFICE ADPTR
18	1	621564	DETAS LIFT CYL,2.00 X 11.00STS
19	2	629773	CAPPLUGS 1 3/4"SQ PLUG,BLK POLY
20	4	900069	5/16UNC X 2" HEX BOLT
21	2	900069N	5/16UNC X 2" SERR FLG BOLT SS
22	2	900076	5/16UNC X 4" HEX BOLT
23	2	900263	1/2UNC X 1" HEX BOLT
24	4	900401	3/4UNC X 1 1/2 HEX BOLT
25	6	914002	5/16UNC HEX STOVER NUT
26	2	914002N	5/16UNC HEX STOVER NUT YZ
27	4	914012	3/4UNC HEX STOVER NUT

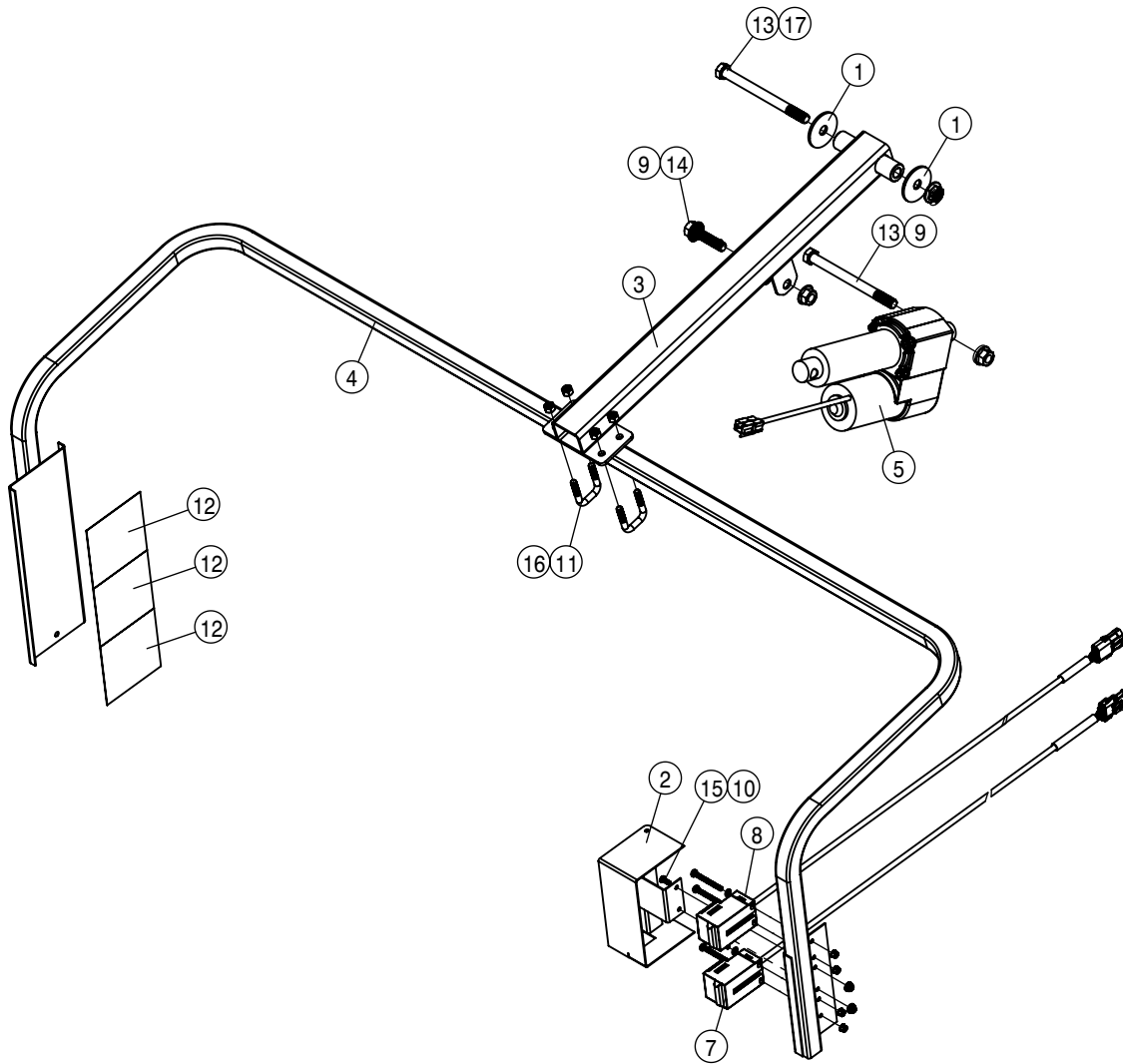

LS SENSOR 2-HEAD ASSEMBLY			
DET	QTY	P/N	DESCRIPTION
1	2	002815	SENSOR ARM WASH, NYL
2	1	002841	LS 42GRU SENSOR SHIELD WLD
3	1	003028	LS SENSOR MT SUPP WLD, STSC 03
4	1	003033	LS SENSOR MT WLD, STS COMBO 03
5	1	292610	LINEAR ACTUATOR, 4" STROKE
NS	1	293188	SENSOR CONNECTOR WIRE ASSY
7	1	293258	UPR LS 9200 SENSOR ASSY, FEM
8	1	293259	UPR LS 9200 SENSOR ASSY, MALE
9	2	470111	1/2-20UNF HEX FLG NUT SM U GR5
10	2	473004	10-32 FLANGE NYLOC NUT
11	2	473980	.31UNC-1.06ID-1.75SQ U-BOLT SS
12	3	650297	REFLECTIVE TAPE,4 X 4, RTC4-4C
13	2	900278	1/2UNC X 6" HEX BOLT
14	1	900519	1/2UNC X 2 HHSFB GR5 MC FT
15	2	903883	10-32 X 1/2 PHIL PAN MACH SCR
16	4	914002	5/16UNC HEX STOVER NUT
17	1	914015	1/2UNC HEX CENTER-LOCK NUT

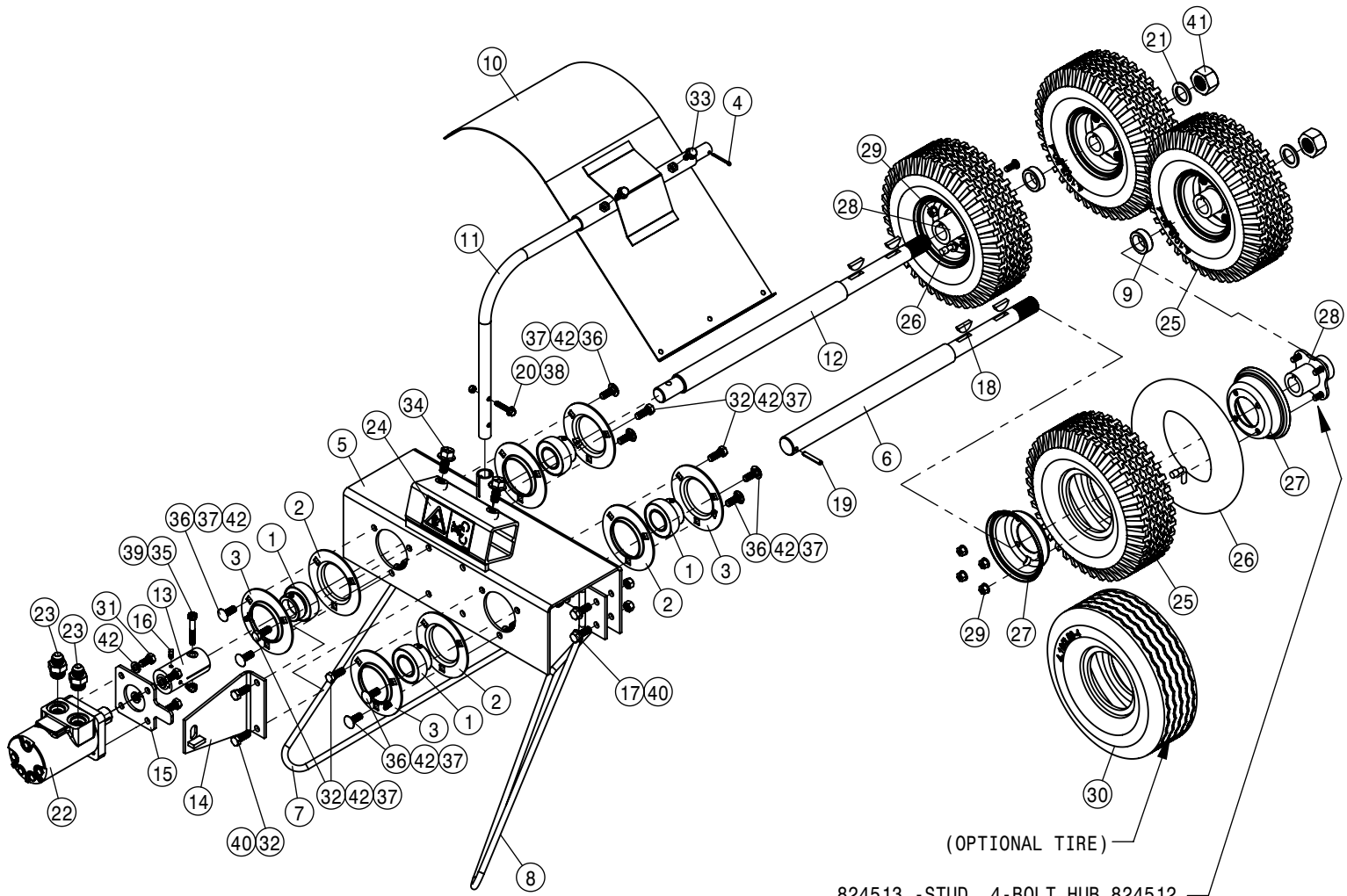

(OPTIONAL TIRE)

824513 -STUD, 4-BOLT HUB 824512

QUAD PULLER HEAD ASSEMBLY			
DET	QTY	P/N	DESCRIPTION
1	4	123024	BGR 1 1/4 BORE SPHERICL RELUB
2	4	123026	FLANGETT 1 1/4
3	4	123035	FLANGETT 1 1/4 180 DEG ZERK
4	1	390984	1/8 X 1 1/4 COTTER PIN
5	1	438369	QUAD PLR FRAME WLD 200 90
6	1	438375	QUAD PLR SHAFT SHORT 200 90
7	1	438381	RH QUAD PLR STALK GUIDE WLD90
8	1	438384	LH QUAD PLR STALK GUIDE WLD90
9	2	438388	.50 HUB SPACER, QUAD PLR
10	1	438415	QUAD PLR SHIELD WLD 200 91
11	1	438419	QUAD PLR SHIELD MT TUBE 91
12	1	438422	QUAD PLR SHAFT LONG 200 91
13	1	438423	QUAD PLR MOTOR COUPLER 200 91
14	1	438424	QUAD PLR MTR MT PLT WLD
15	1	438425	QUAD PLR MTR MT 200 91
16	2	470199	1/4UNC X 3/8 SQHD CUP SET SCR
17	4	470460	3/8 X 1" SERR FLG BOLT
18	4	472020	WOODRUFF KEY # 18 1/4 X 1 1/8
19	1	473805	ROLL PIN, 1/4 X 1 1/2
20	1	473836	1/4UNC X 1 1/4 FLANGE BOLT SS
21	2	483032	1 1/2 X 1" X .134TH MACH WASH

QUAD PULLER HEAD ASSEMBLY			
DET	QTY	P/N	DESCRIPTION
22	1	610547	HYD MOTOR 4.5CI 1IN SHFT
23	2	618327	3/4MJIC-7/8MOR ADPTR
24	1	650259	DECAL MOVING PARTS ROLLER
25	4	824509	4.10/3.50-4 2PLY STUD TIRE
26	4	824510	4.10/3.50-4 BENT STEM TUBE
27	4	824511	RIM, 410-4 2PC
28	4	824512	HUB, 4-BOLT, 1" KEYED BORE
29	16	824514	WHL NUT, 4-BOLT HUB
30	4	824516	4.10/3.50 2P SAWTOOTH TIRE
31	4	900128	3/8UNC X 3/4 HEX BOLT
32	6	900129	3/8UNC X 1" HEX BOLT
33	2	900486	5/16UNC X 3/4 HHSFB SS
34	2	900516	1/2UNC X 1 HHSFB GR5 MC
35	1	900830	5/16UNC X 2" HEX BOLT GR8 YZ
36	8	901129	3/8-16 X 1 CARRIAGE BOLT
37	12	910004	3/8UNC HEX NUT
38	1	914000	1/4UNC HEX STOVER NUT
39	1	914002	5/16UNC HEX STOVER NUT
40	6	914004	3/8UNC HEX STOVER NUT
41	2	914016	1" UNC HEX STOVER NUT
42	16	920502	3/8 LOCK WASHER



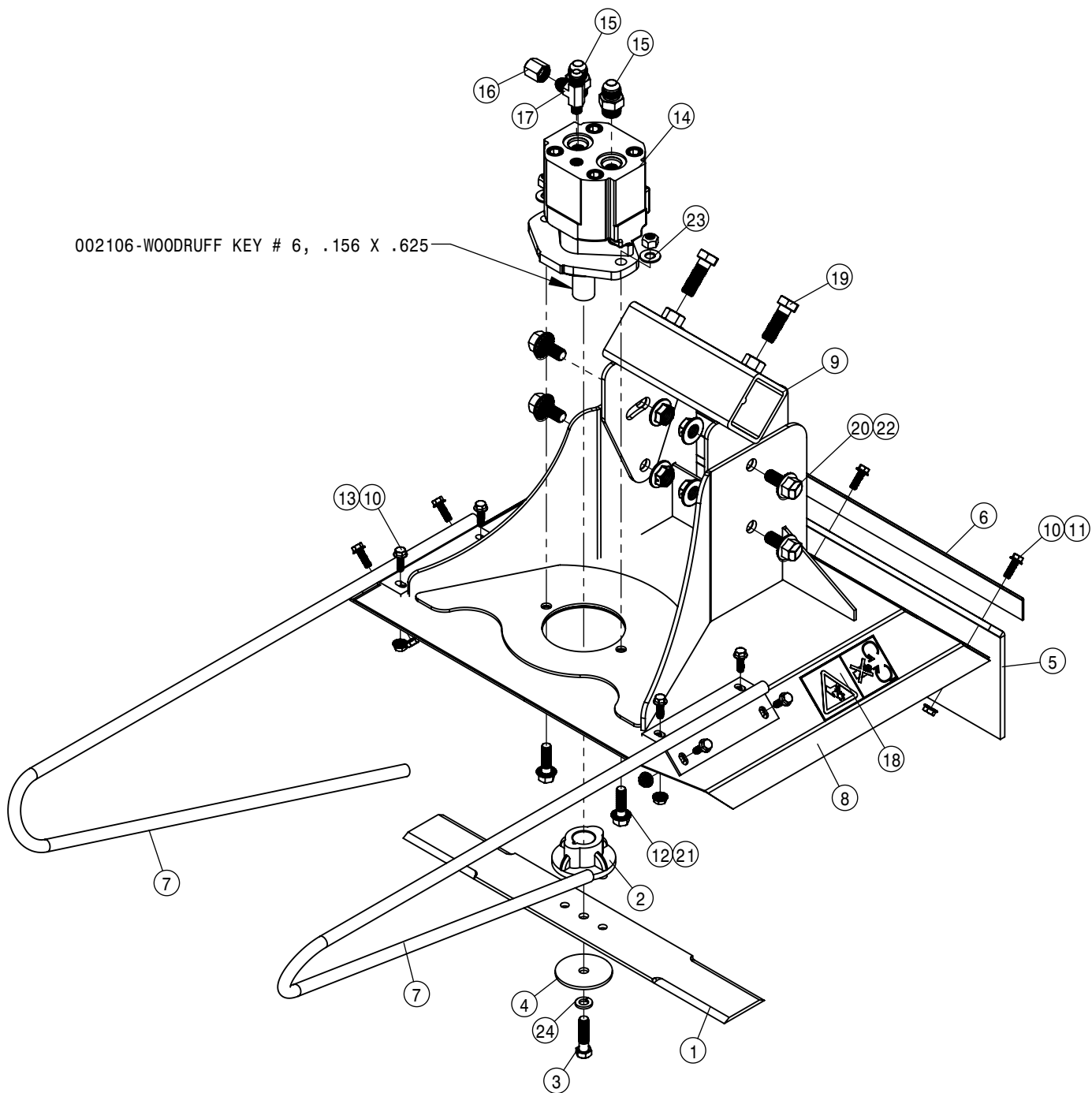

002106-WOODRUFF KEY # 6, .156 X .625

19" CUTTER HEAD ASSEMBLY			
DET	QTY	P/N	DESCRIPTION
1	1	002103	CUTR BLADE 18 IN
2	1	002104	CUTTER BLADE ADAPTER, RD LUG
3	1	002107	3/8UNF X 1 1/2 HEX BOLT CUTR
4	1	002108	STEEL WASHER CUTTER BLADE
5	1	002256	19" REAR CUTR DECK EXT FLAP 04
6	1	002257	19" REAR CUTR DECK FLAP KPR 04
7	2	002258	19" CUTR STALK GUIDE WLD
8	1	002265	19" CUTTER DECK WLD 08
9	1	002269	CUTR TUBE MT WLD 08
10	11	470118	1/4 UNC X 3/4 SER FLG BOLT
11	3	470121	1/4 UNC SERR FLG LOCK NUT
12	2	470329	3/8UNC X 1 1/4 SERR FLG HEX BOLT

19" CUTTER HEAD ASSEMBLY			
DET	QTY	P/N	DESCRIPTION
13	8	473832	1/4UNC HEX FLANGE LOCK NUT SS
14	1	610755	BARNES HYD MOTOR, D-SERIES 01
15	2	611125	3/4MJIC-3/4MOR ADPTR
16	1	618531	9/16FJIC CAP NUT
17	1	618546	1/8MNPT RUN TEE-9/16MJIC
18	2	650258	DECAL CUTTING BLADES
19	2	900265	1/2UNC X 1 1/2 HEX BOLT
20	4	900516	1/2UNC X 1 HHSFB GR5 MC
21	2	914004	3/8UNC HEX STOVER NUT
22	4	914015	1/2UNC HEX CENTER-LOCK NUT
23	2	920002	3/8 SAE FLAT WASHER
24	1	920502	3/8 LOCK WASHER

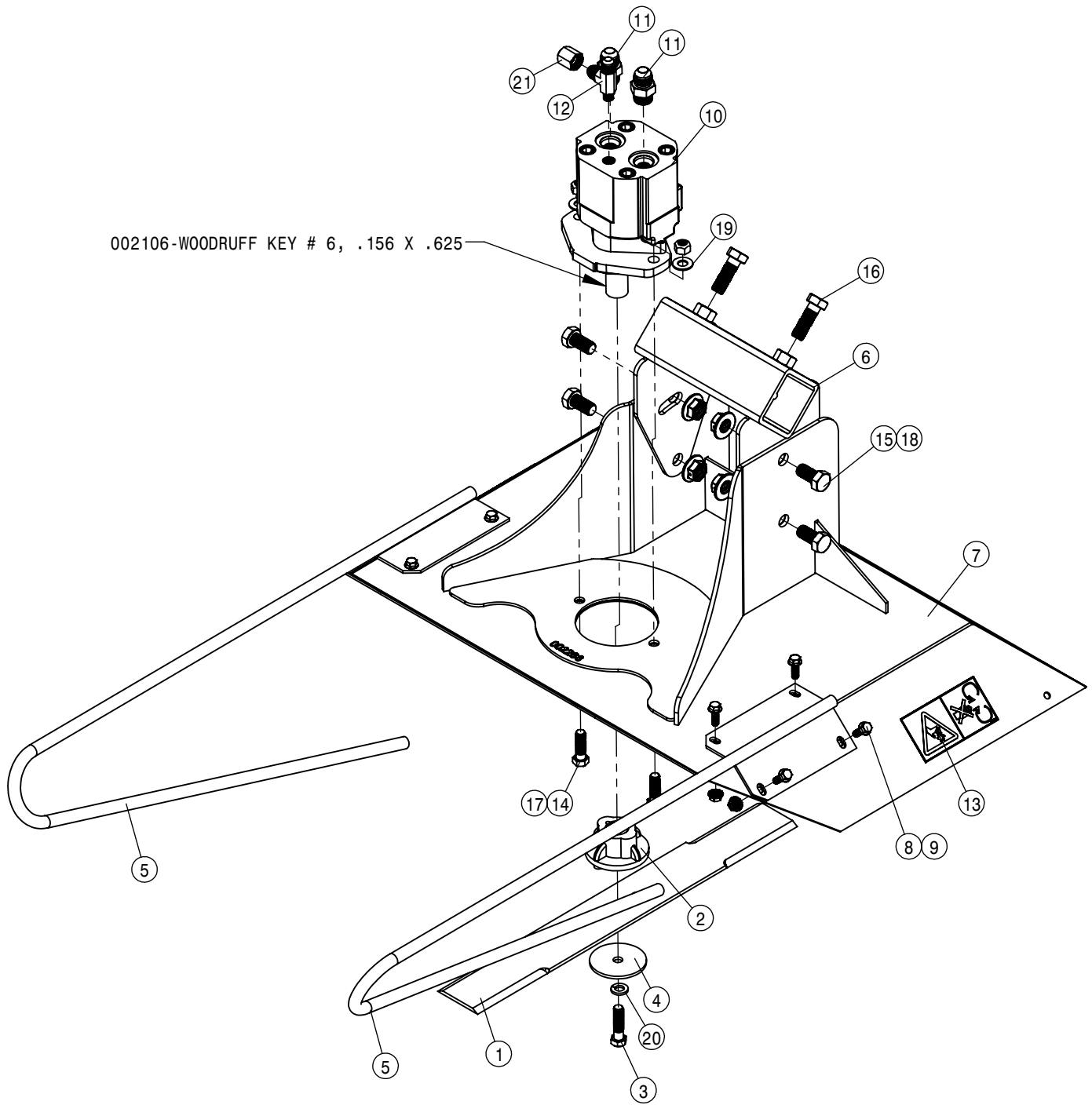

26" CUTTER HEAD ASSEMBLY			
DET	QTY	P/N	DESCRIPTION
1	1	002103	CUTR BLADE 18 IN
2	1	002104	CUTTER BLADE ADAPTER, RD LUG
3	1	002107	3/8UNF X 1 1/2 HEX BOLT CUTR
4	1	002108	STEEL WASHER CUTTER BLADE
5	2	002215	CUTR STALK GUIDE WLD 8200 85
6	1	002269	CUTR TUBE MT WLD 08
7	1	002272	26" CUTTER DECK WLD
8	8	470118	1/4 UNC X 3/4 SER FLG BOLT
9	8	470121	1/4 UNC SERR FLG LOCK NUT
10	1	610755	BARNES HYD MOTOR, D-SERIES 01
11	2	611125	3/4MJIC-3/4MOR ADPTR

26" CUTTER HEAD ASSEMBLY			
DET	QTY	P/N	DESCRIPTION
12	1	618546	1/8MNPT RUN TEE-9/16MJIC
13	2	650258	DECAL CUTTING BLADES
14	2	900130	3/8UNC X 1 1/4 HEX BOLT
15	4	900263	1/2UNC X 1" HEX BOLT
16	2	900265	1/2UNC X 1 1/2 HEX BOLT
17	2	914004	3/8UNC HEX STOVER NUT
18	4	914015	1/2UNC HEX CENTER-LOCK NUT
19	2	920002	3/8 SAE FLAT WASHER
20	1	920502N	3/8 LOCK WASHER
21	1	618531	9/16FJIC CAP NUT

THREE HEAD ASSEMBLY

LEFT SIDE OF OPERATOR

RIGHT SIDE OF OPERATOR

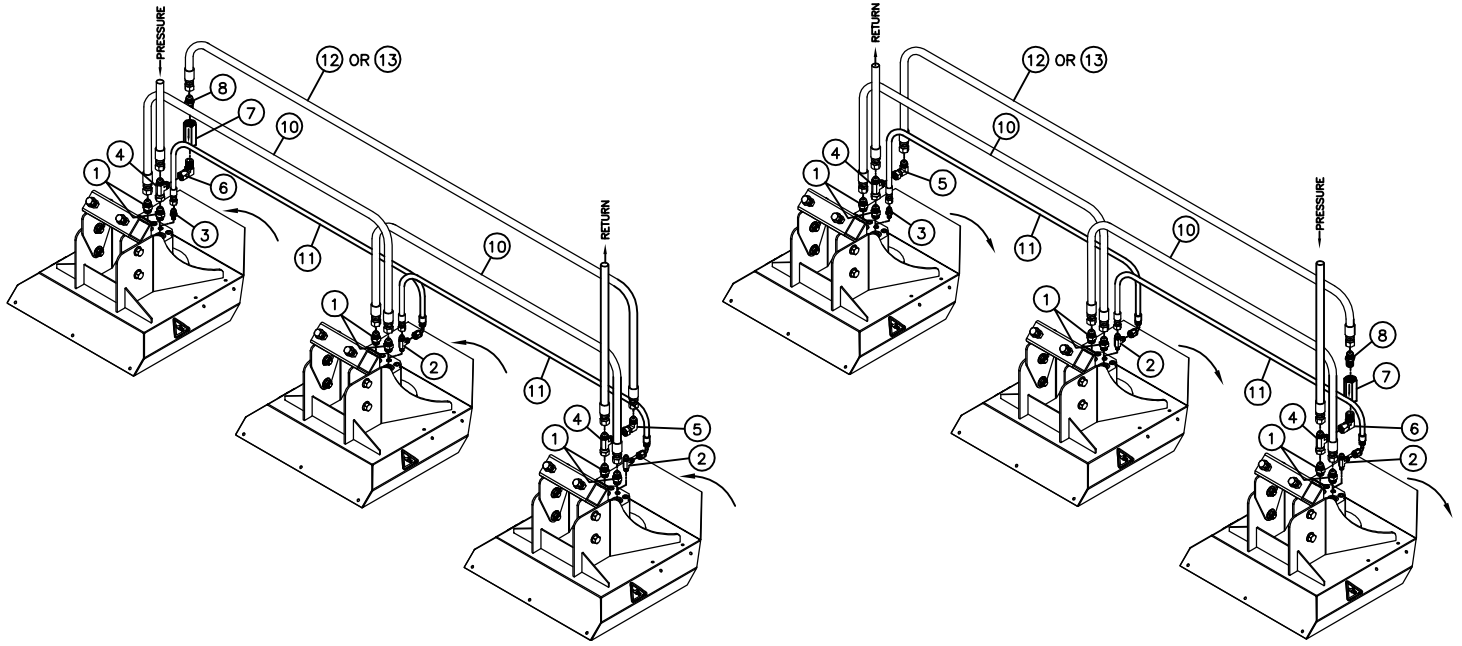

TWO HEAD ASSEMBLY

LEFT SIDE OF OPERATOR

RIGHT SIDE OF OPERATOR

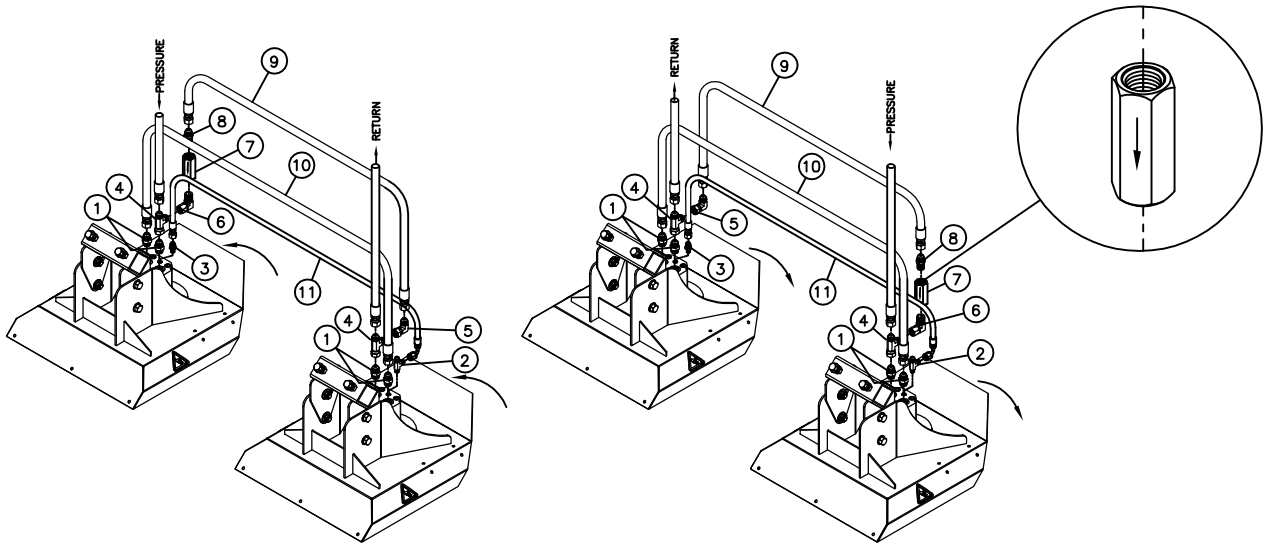

HYD SCHEM, CUTTER CHECK VLV 204 07

DET. QTY PART NO. DESCRIPTION

DET.	QTY	PART NO.	DESCRIPTION
1	611125	3/4MJIC-3/4MOR ADPTR	
2	618546	1/8MNPT RUN TEE-9/16MJIC	
3	618530	9/16MJIC-1/8MNPT ADPTR	
4	618451	3/4FJIC SW RUN TEE-3/4MJIC	
5	618609	3/4MJIC-90-3/4FJIC SWIV LBO	
6	618620	3/4FJX-90-1/2MNPT ADPTR	
7	690338	LINE CHECK VALVE HYD .50NPT	
8	611147	3/4MJIC-1/2MNPT ADPTR	
9	616025	08C1T-08FJX-08FJX-50	H/A
10	614368	08C1T-08FJX-08FJX-60	H/A
11	616422	04C1T-06FJX-06FJX90-50	H/A
12	616031	08C1T-08FJX-08FJX-83	H/A
13	614662	08C1T-08FJX-08FJX-72	H/A

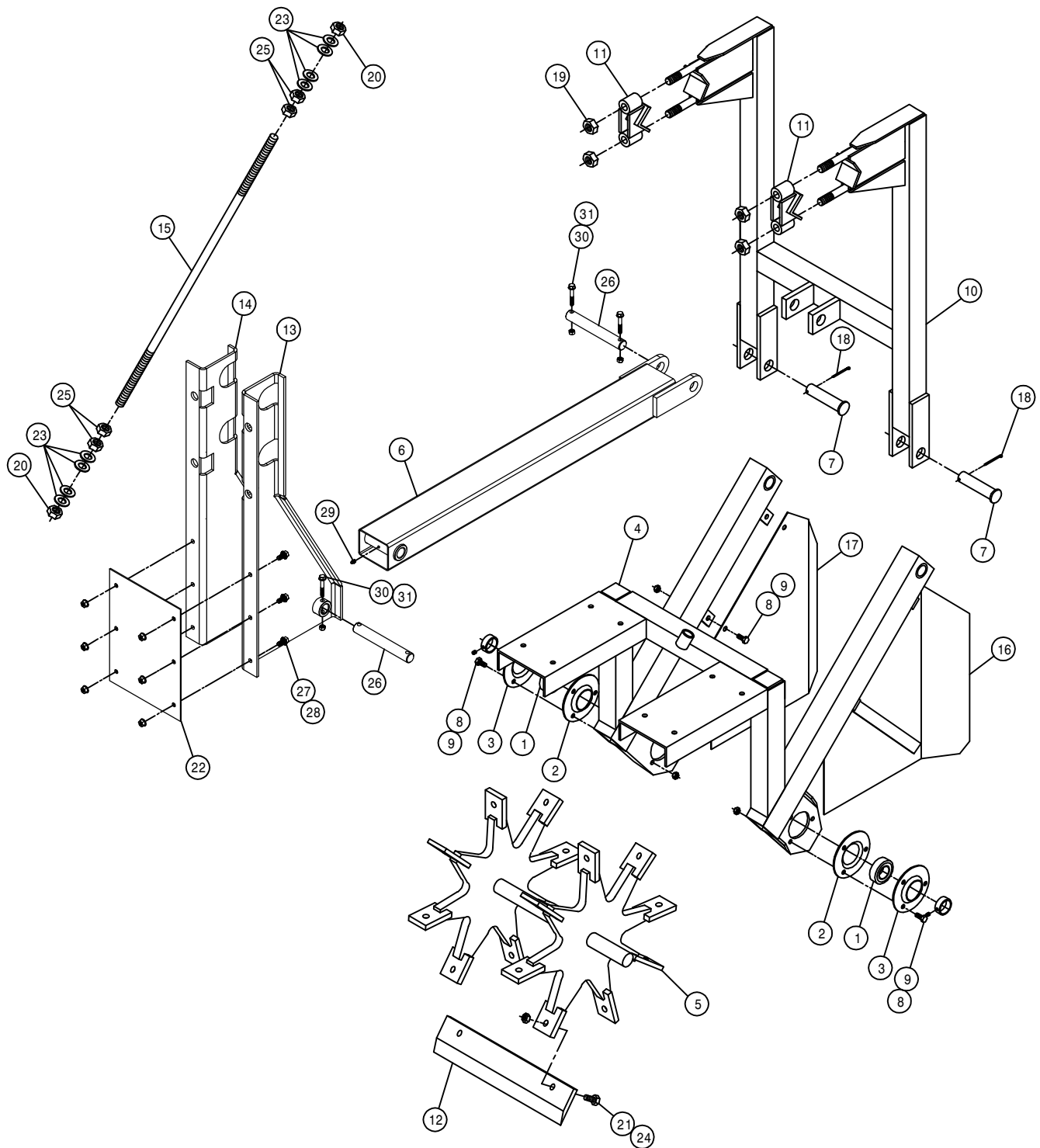

15" MALE ROW CHOPPER ASSEMBLY

DET.	QTY	PART NO.	DESCRIPTION	DET.	QTY	PART NO.	DESCRIPTION
1	2	123024	BGR 1 1/4 BORE SPHERICL RELUB	17	1	270846	LH SHLD WLD MALE ROW CHOPPER
2	2	123026	FLANGETT 1 1/4	18	2	470162	COTTER PIN 3/16 X 1 1/2
3	2	123035	FLANGETT 1 1/4 180 DEG ZERK	19	4	914010	5/8UNC HEX STOVER NUT
4	1	270814	LWR FRAME WLD MALE ROW CHOP	20	2	914012	3/4UNC HEX STOVER NUT
5	1	270860	BLADE MT WHL WLD, CHOPPER 92	21	16	900265	1/2UNC X 1 1/2 HEX BOLT
6	1	270937	LWR LIFTARM WLDMT,MALE CHOP 09	22	1	270944	LWR LIFTARM MT TIE PLT,CHOP 09
7	2	472012	CLEVIS PIN, 1.00 X 3.25	23	8	920006	3/4 SAE FLAT WASHER
8	10	900129	3/8UNC X 1" HEX CAP BOLT	24	16	914008	1/2UNC HEX STOVER NUT
9	10	914004	3/8UNC HEX STOVER NUT	25	4	910012	3/4UNC HEX NUT
10	1	270855	UPR FRAME WLD MALE ROW CHOP91	26	2	270945	LWR LIFTARM PIN,MALE CHOP 09
11	2	270833	TOOL BAR CLAMP WLD MALE CHOP	27	6	470087	3/8UNC HEX SER FLG NUT
12	8	270838	CHOPPER BLADE, MALE ROW, 15"	28	6	470409	3/8UNC X 3/4 SER FLG BOLT
13	1	270940	RH LWR LIFTARM MT WLD,CHOP 09	29	1	471005	GREASE ZERK, 1/4-28 X 1/2
14	1	270941	LH LWR LIFTARM MT WLD,CHOP 09	30	4	900069	5/16UNC X 2" HEX BOLT
15	1	270844	ADJ ROD MALE ROW CHOPPER	31	4	914002	5/16UNC HEX STOVER NUT
16	1	270845	RH SHLD WLD MALE ROW CHOPPER				

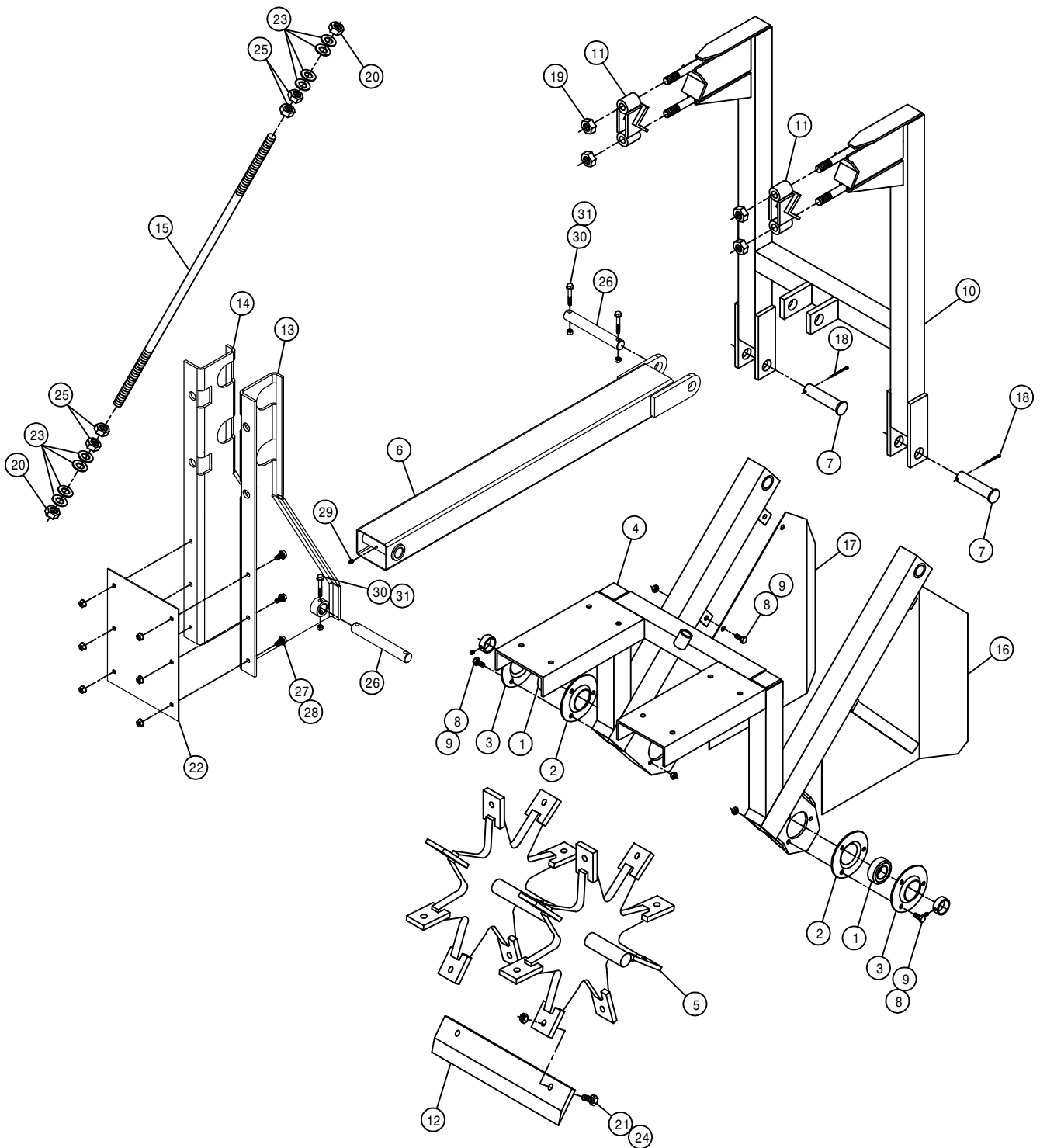

20" MALE ROW CHOPPER ASSEMBLY

DET.	QTY	PART NO.	DESCRIPTION	DET.	QTY	PART NO.	DESCRIPTION
1	2	123024	BGR 1 1/4 BORE SPHERICL RELUB	17	1	270846	LH SHLD WLD MALE ROW CHOPPER
2	2	123026	FLANGETT 1 1/4	18	2	470162	COTTER PIN 3/16 X 1 1/2
3	2	123035	FLANGETT 1 1/4 180 DEG ZERK	19	4	914010	5/8UNC HEX STOVER NUT
4	1	270872	LWR FRAME WLD,20"MALE CHOPR95	20	2	914012	3/4UNC HEX STOVER NUT
5	1	270874	BLADE MT WHL WLD,20"CHOPR 95	21	16	900265	1/2UNC X 1 1/2 HEX BOLT
6	1	270937	LWR LIFTARM WLD,MALE CHOP 09	22	1	270944	LWR LIFTARM MT TIE PLT,CHOP 09
7	2	472012	CLEVIS PIN, 1.00 X 3.25	23	8	920006	3/4 SAE FLAT WASHER
8	10	900129	3/8UNC X 1" HEX CAP BOLT	24	16	914008	1/2UNC HEX STOVER NUT
9	10	914004	3/8UNC HEX STOVER NUT	25	4	910012	3/4UNC HEX NUT
10	1	270876	UPR FRAME WLD,20"MALE CHOPR95	26	2	270945	LWR LIFTARM PIN,MALE CHOP 09
11	2	270833	TOOL BAR CLAMP WLD MALE CHOP	27	6	470087	3/8UNC HEX SER FLG NUT
12	8	270866	CHOPPER BLADE, MALE ROW, 20"	28	6	470409	3/8UNC X 3/4 SER FLG BOLT
13	1	270940	RH LWR LIFTARM MT WLD,CHOP 09	29	1	471005	GREASE ZERK, 1/4-28 X 1/2
14	1	270941	LH LWR LIFTARM MT WLD,CHOP 09	30	4	900069	5/16UNC X 2" HEX BOLT
15	1	270867	ADJ ROD WLD,MALE ROW CHOPR 95	31	4	914002	5/16UNC HEX STOVER NUT
16	1	270845	RH SHLD WLD MALE ROW CHOPPER				

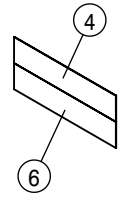
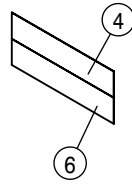
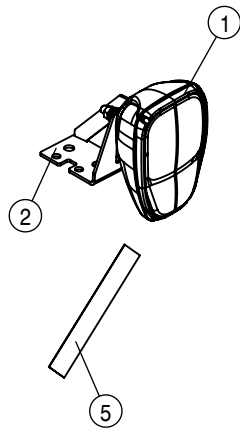
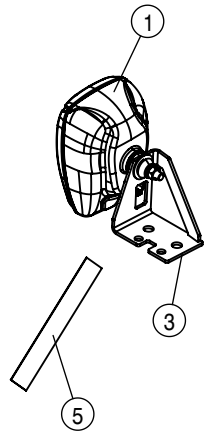

TOOLBAR HEAD LIGHT ASSEMBLY			
DET	QTY	P/N	DESCRIPTION
1	2	292556	HEAD/FLASHER LIGHT
2	1	345153	LIGHT BRKT 204 LH WLD
3	1	345155	LIGHT BRKT 204 RH WLD
4	2	JD5920	2 X 9 RETRO-REFLECTOR RED
5	2	JD5921	2 X 9 RETRO-REFLECTOR YELLOW
6	2	JD5922	2 X 9 RETRO-REFLECTOR ORANGE

This Page Intentionally Blank

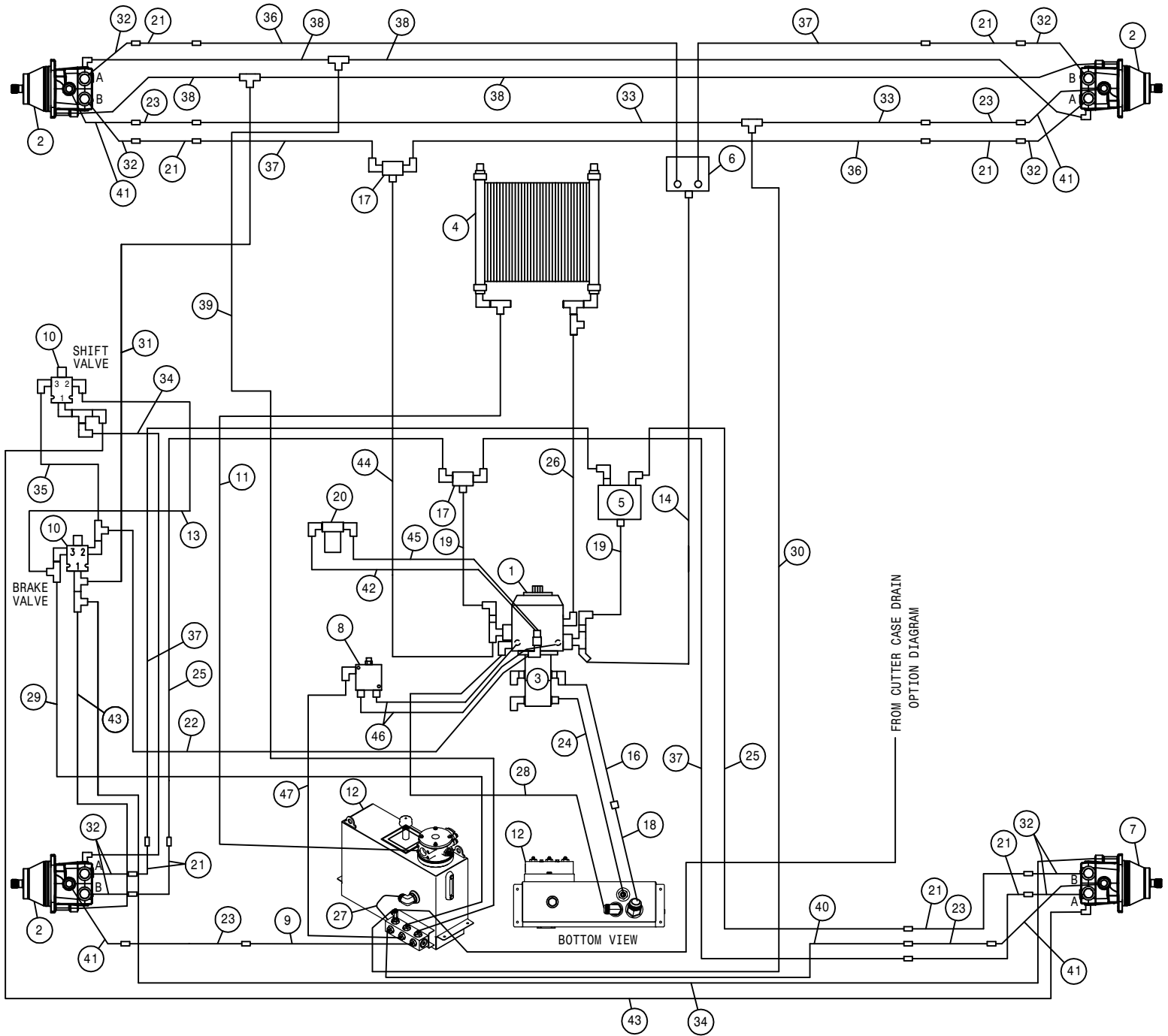



204SP BASIC MACHINE CUMM HYD DIAG 15  
REFERENCE DRAWING NO. 499187s1\_RevA

DET.	QTY	PART NO.	DESCRIPTION	DET.	QTY	PART NO.	DESCRIPTION	
1	1	607572	SUND 100CC PUMP,23T B-MT /FILT	25	2	616297	08-381-10MJ-10FJX-88	H/A
2	3	606193	SAUER WHL MOTOR,KC-38CC	26	1	617329	16-811-16FJX-16FJX-58	H/A
3	1	606352	TANDEM PUMP,606353 & 606929	27	1	613762	20-811-20FJX-20FJX90-28	H/A
4	1	317581	OIL COOLER BLISSFIELD 87007	28	1	617333	20-811-20FJX-20FJX-25	H/A
5	1	610609	TRACTION VLV,STL,66S,40GPM	29	1	617334	04-451TC-04FJX-06FJX-20	H/A
6	1	610586	POSITRACTION VLV,STL,88SP 60G	30	1	617328	08-451TC-06FJX-08FJX-156	H/A
7	1	606203	SAUER WHL MOTOR, KC-38CC	31	1	611246	04-482TC-06FJX-06FJX-174	H/A
8	1	610580	REMOTE FLUSHING VALVE, SUND	32	8	616433	10-787TC-10MJ-10FJX45-17	H/A
9	1	617331	06-451TC-06FJX-08MJX-72 H/A	33	2	616156	06-482TC-08MJ-06FJX-92	H/A
10	2	701625	BRAKE/LADDER VLV ASSY STS'14	34	2	611357	04-482TC-06FJX-06FJX90-114	H/A
11	1	617335	24-811-24FJX-24FLANGE90-89 H/A	35	1	614713	04-482TC-06FJX-06FJX-24	H/A
12	1	317411	WLD HYD RES, 204 T3 2015	36	2	616160	08-381-10MJ-10FJX-105	H/A
13	1	617340	04-451TC-04FJX-08FJX-13 H/A	37	4	616159	08-381-10MJ-10FJX-98	H/A
14	1	616934	12-721-16FJX-16FJX-117 H/A	38	4	611202	04-482TC-06FJX-06FJX-136	H/A
15	1	606467	RETURN MANIFOLD - DTS	39	1	617336	04-451TC-06FJX-06FJX90-142	H/A
16	1	362489	SUCTION TUBE ASSY	40	1	617327	06-451TC-06FJX-08MJX-81	H/A
17	2	606356	1 1/16FOR MANIFOLD,3 #12PORTS	41	4	616432	08-381-08MJ-08FJX45-15	H/A
18	1	617339	32-811-32FJX-32FJX-21 H/A	42	1	615633	08-482TC-08FJX-08FJX-23	H/A
19	2	611354	12-451TC-12FJX-12FJX-21 H/A	43	2	614639	04-482TC-06FJX-06FJX-126	H/A
20	1	605608	HYD FILTER HEAD, DONALDSON	44	1	616933	12-721-16FJX-16FJX-114	H/A
21	8	615840	LEG HYD TUBE ASSY, 204SP 07	45	1	616034	08-482TC-08FJX-08FJX-17	H/A
22	1	617334	04-451TC-04FJX-06FJX-20 H/A	46	2	616253	04-381-06FJX-06FJX-19	H/A
23	4	615841	LEG CASE DRN TUBE ASSY,204SP07	47	1	617332	04-451TC-06FJX-06FJX-17	H/A
24	1	617338	12-811-12FJX-12FJX-15 H/A					

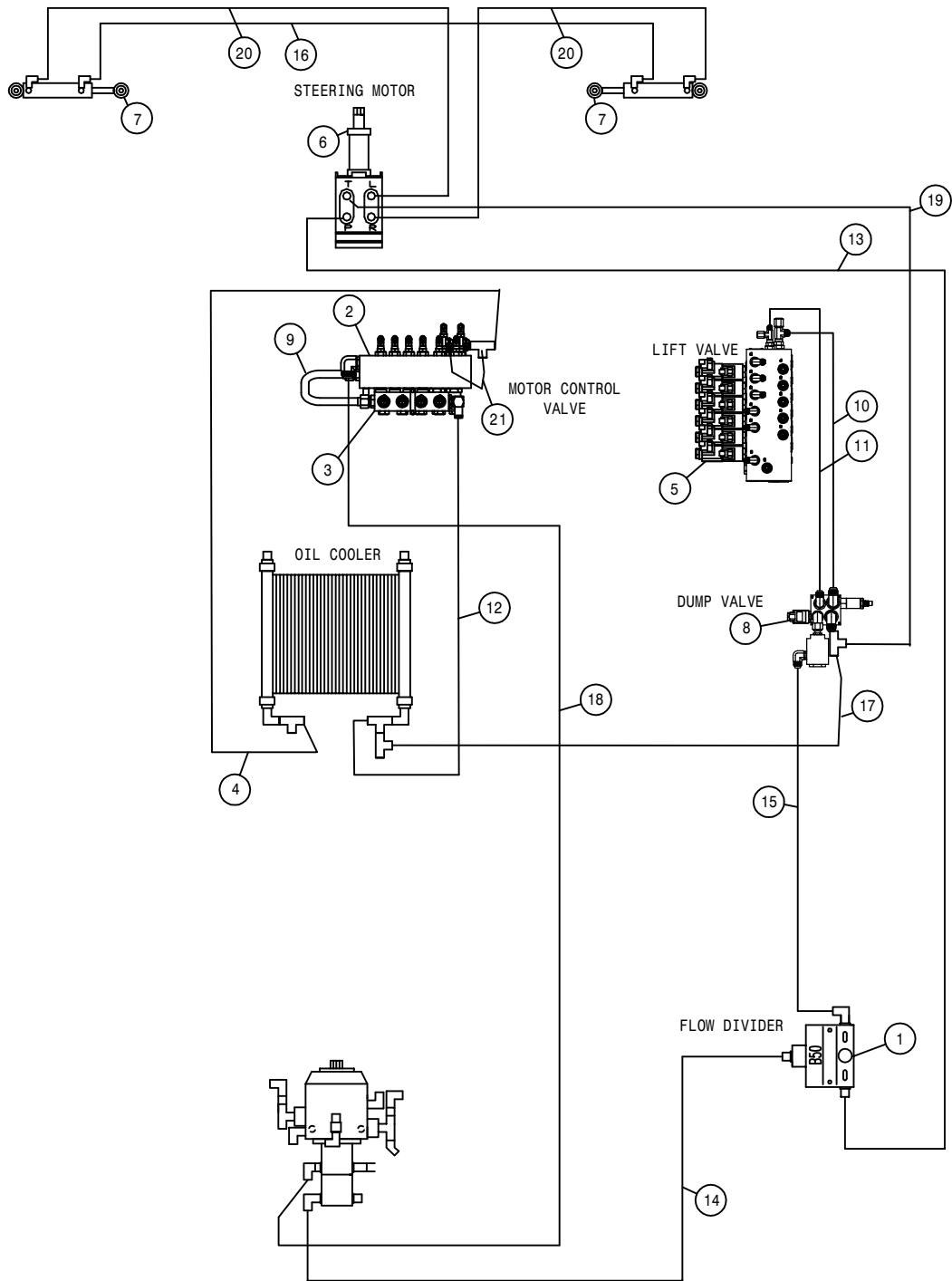

204SP BASIC MACHINE CUMM HYD DIAG 15  
 REFERENCE DRAWING NO. 499187s2\_RevA

DET.	QTY	PART NO.	DESCRIPTION	DET.	QTY	PART NO.	DESCRIPTION	
1	1	607504	FLO DIV B50 2-8GPM 7/8 FOR	12	1	617337	20-811-20FJX-20FJX-73	H/A
2	1	606262	MTR CONTROL ELECT VLV, SAUER 07	13	1	615727	04-482TC-06FJX-06FJX-75	H/A
3	1	606029	RETURN MANIFOLD BLOCK, STS 03	14	1	616147	10-482TC-10FJX-10FJX-89	H/A
4	1	611355	10-451TC-08FJX-10FJX90-90 H/A	15	1	615473	06-482TC-06FJX-08FJX-18	H/A
5	1	606285	LIFT VALVE, STS COMBO, SAUER	16	1	611246	04-482TC-06FJX-06FJX-174	H/A
6	1	749318	STRG MTR, 7.3CID, NON-LOAD 1031	17	1	617341	08-451TC-08FJX-08FJX-36	H/A
7	2	621516	HYD CYL, 2.00 X 7.00 X 1.000	18	1	616257	20-381-20FJX-20FJX-144	H/A
8	1	606330	DUMP MANIF VALVE SAUER	19	1	617330	06-451TC-06FJX-06FJX-46	H/A
9	1	615799	MTR CTRL RET TUBE ASSY, 204 07	20	2	614639	04-482TC-06FJX-06FJX-126	H/A
10	1	616007	08-482TC-08FJX-10FJX-50 H/A	21	1	617254	08-451TC-08FJX-08FJX90-21	H/A
11	1	616008	06-482TC-08FJX-06FJX90-52 H/A					

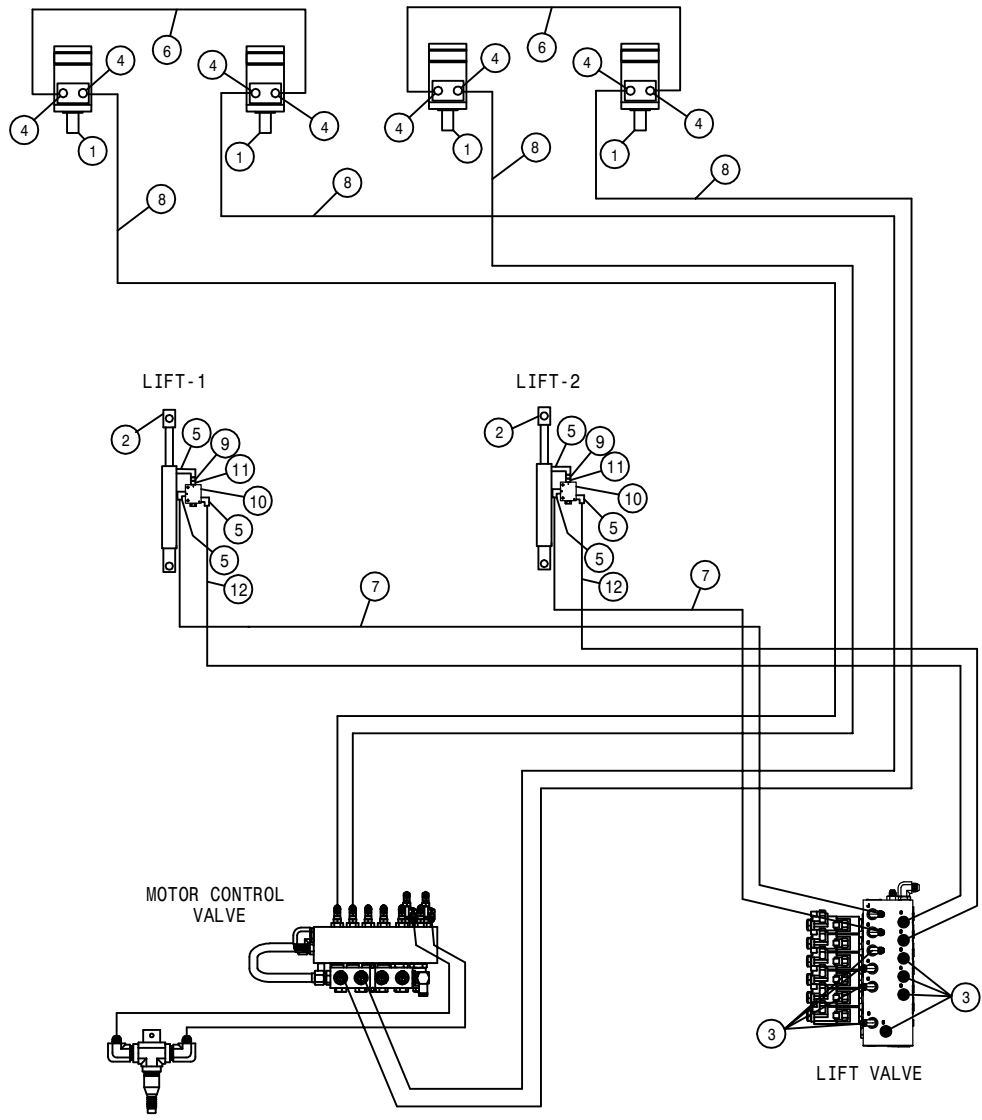

204 4R QUAD 2L LS HYD DIAG 2014  
 REFERENCE DRAWING NO. 499291

DET.	QTY	PART NO.	DESCRIPTION	DET.	QTY	PART NO.	DESCRIPTION
1	4	610547	HYD MOTOR 4.5CI 1IN SHFT	7	2	615729	04-482TC-06FJX-06FJX-84 H/A
2	2	621564	HYD CYL,2.00 X 11.00 X 1.50 1W	8	4	616168	08-482TC-08FJX-08FJX-139 H/A
3	8	618531	9/16FJIC CAP NUT	9	2	618732	9/16JIC .031 ORIFICE ADPTR
4	8	618327	3/4MJIC-7/8MOR ADPTR	10	2	607565	CHECK VLV,PILOT TO OPEN, SUN
5	6	618119	9/16MJIC-90-9/16MOR LBO	11	2	618668	9/16FJIC SWIV-9/16MOR ADPTR
6	2	616025	08-482TC-08FJX-08FJX-50 H/A	12	2	616861	04-451TC-06FJX-06FJX90-88 H/A

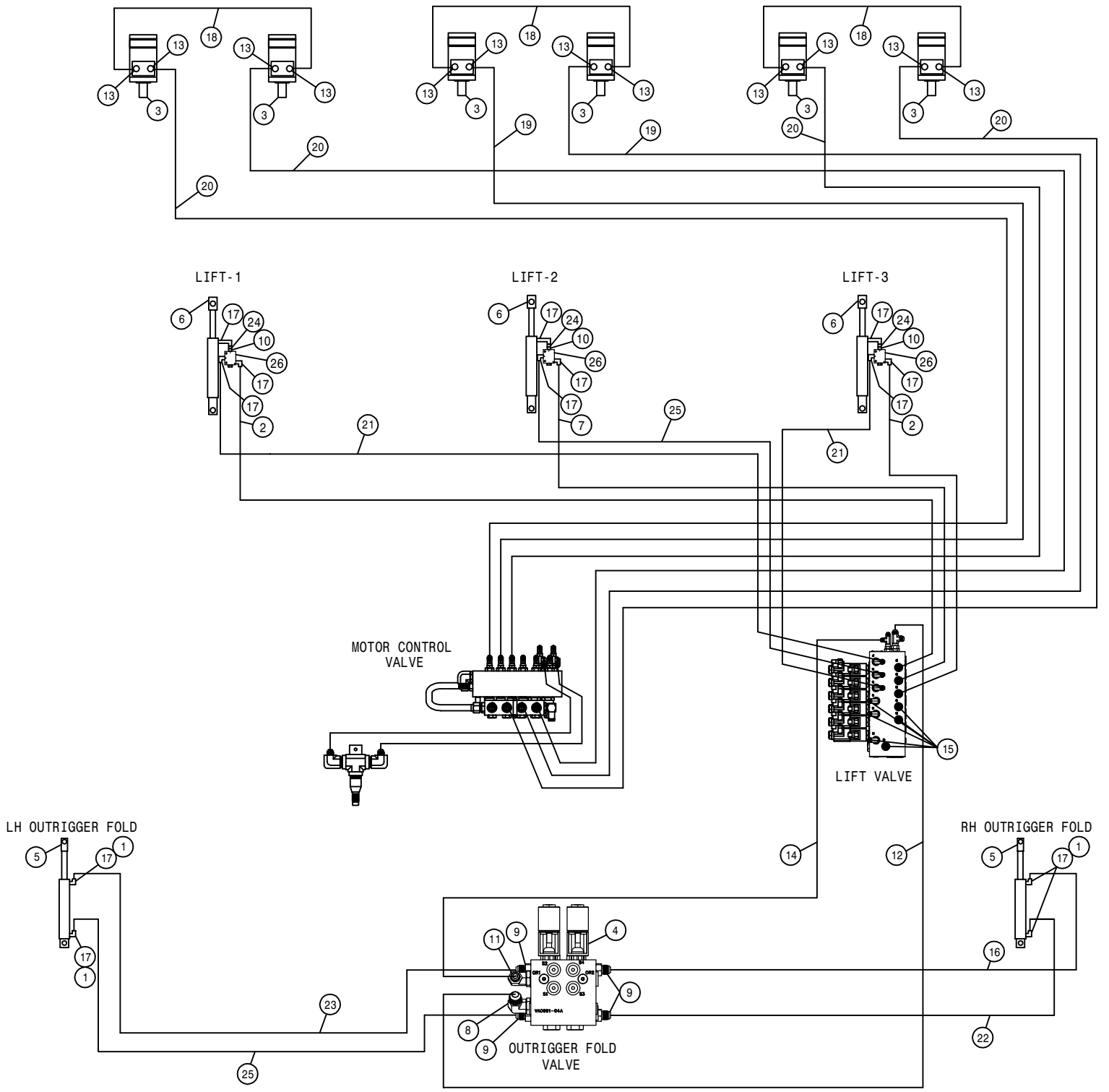

204SP 6R QUAD 3L LS HYD DIAG 2014  
REFERENCE DRAWING NO. 499292

DET.	QTY	PART NO.	DESCRIPTION	DET.	QTY	PART NO.	DESCRIPTION	
1	4	618731	9/16JIC .025 ORIFICE ADPTR	14	1	616117	06-451TC-06FJX-06FJX-17	H/A
2	2	616864	04-451TC-06FJX-06FJX90-137 H/A	15	6	618531	9/16FJIC CAP NUT	
3	6	610547	HYD MOTOR 4.5CI 1IN SHFT	16	1	614152	04-482TC-06FJX-06FJX-114	H/A
4	1	606249	MANIFOLD,TRD ADJ PWRSYS	17	13	618119	9/16MJIC-90-9/16MOR LBO	
5	2	621520	HYD CYL, 2.00 X 10.00 X 1.000	18	3	616025	08-482TC-08FJX-08FJX-50	H/A
6	3	621564	HYD CYL,2.00 X 11.00 X 1.50 1W	19	2	614689	08-482TC-08FJX-08FJX-120	H/A
7	1	616862	04-451TC-06FJX-06FJX90-92 H/A	20	4	614690	08-482TC-08FJX-08FJX-192	H/A
8	1	618241	3/4MJIC-90-3/4MOR LBO	21	2	614101	04-482TC-06FJX-06FJX-133	H/A
9	4	618126	9/16MJIC-9/16MOR ADPTR	22	1	616205	04-482TC-06FJX-06FJX-117	H/A
10	3	618668	9/16FJIC SWIV-9/16MOR ADPTR	23	1	615727	04-482TC-06FJX-06FJX-75	H/A
11	1	618115	9/16MJIC-90-3/4MOR LBO	24	3	618732	9/16JIC .031 ORIFICE ADPTR	
12	1	616505	08-451TC-08FJX-08FJX90-24 H/A	25	2	614077	04-482TC-06FJX-06FJX-88	H/A
13	12	618327	3/4MJIC-7/8MOR ADPTR	26	3	607565	CHECK VLV,PILOT TO OPEN, SUN	

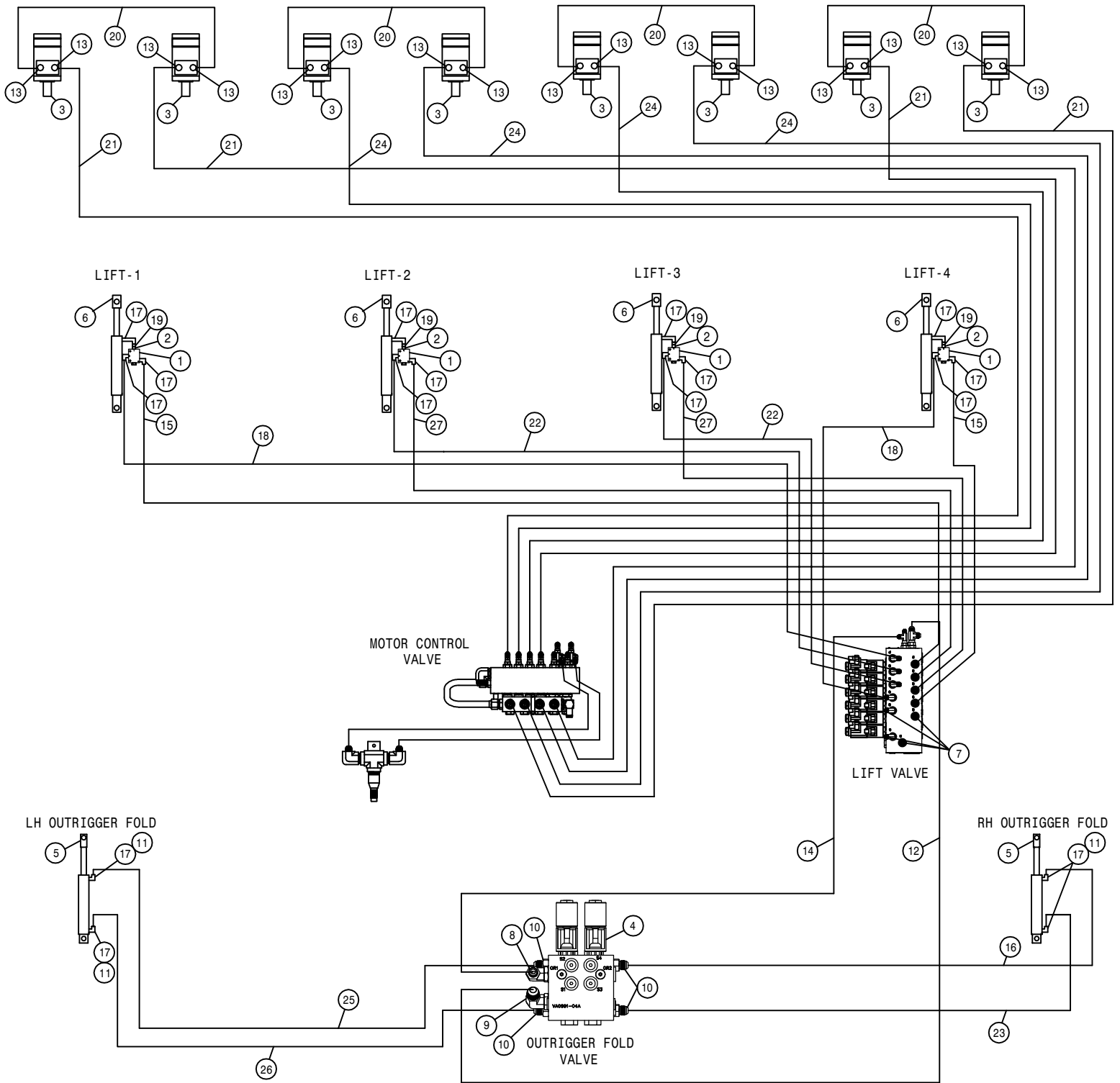



204SP 8R QUAD 4L LS HYD DIAG 2014  
REFERENCE DRAWING NO. 499299

DET.	QTY	PART NO.	DESCRIPTION	DET.	QTY	PART NO.	DESCRIPTION
1	4	607565	CHECK VLV,PILOT TO OPEN, SUN	15	2	616867	04-451TC-06FJX-06FJX90-186 H/A
2	4	618668	9/16FJIC SWIV-9/16MOR ADPTR	16	1	614152	04-482TC-06FJX-06FJX-114 H/A
3	8	610547	HYD MOTOR 4.5CI 1IN SHFT	17	16	618119	9/16MJIC-90-9/16MOR LBO
4	1	606249	MANIFOLD,TRD ADJ PWRSYS	18	2	611262	04-482TC-06FJX-06FJX-182 H/A
5	2	621520	HYD CYL, 2.00 X 10.00 X 1.000	19	4	618732	9/16JIC .031 ORIFICE ADPTR
6	4	621564	HYD CYL,2.00 X 11.00 X 1.50 1W	20	4	616025	08-482TC-08FJX-08FJX-50 H/A
7	4	618531	9/16FJIC CAP NUT	21	4	614384	08-482TC-08FJX-08FJX-237 H/A
8	1	618115	9/16MJIC-90-3/4MOR LBO	22	2	615729	04-482TC-06FJX-06FJX-84 H/A
9	1	618241	3/4MJIC-90-3/4MOR LBO	23	1	616205	04-482TC-06FJX-06FJX-117 H/A
10	4	618126	9/16MJIC-9/16MOR ADPTR	24	4	616168	08-482TC-08FJX-08FJX-139 H/A
11	4	618731	9/16JIC .025 ORIFICE ADPTR	25	1	615727	04-482TC-06FJX-06FJX-75 H/A
12	1	616505	08-451TC-08FJX-08FJX90-24 H/A	26	1	614077	04-482TC-06FJX-06FJX-88 H/A
13	16	618327	3/4MJIC-7/8MOR ADPTR	27	2	616861	04-451TC-06FJX-06FJX90-88 H/A
14	1	616117	06-451TC-06FJX-06FJX-17 H/A				

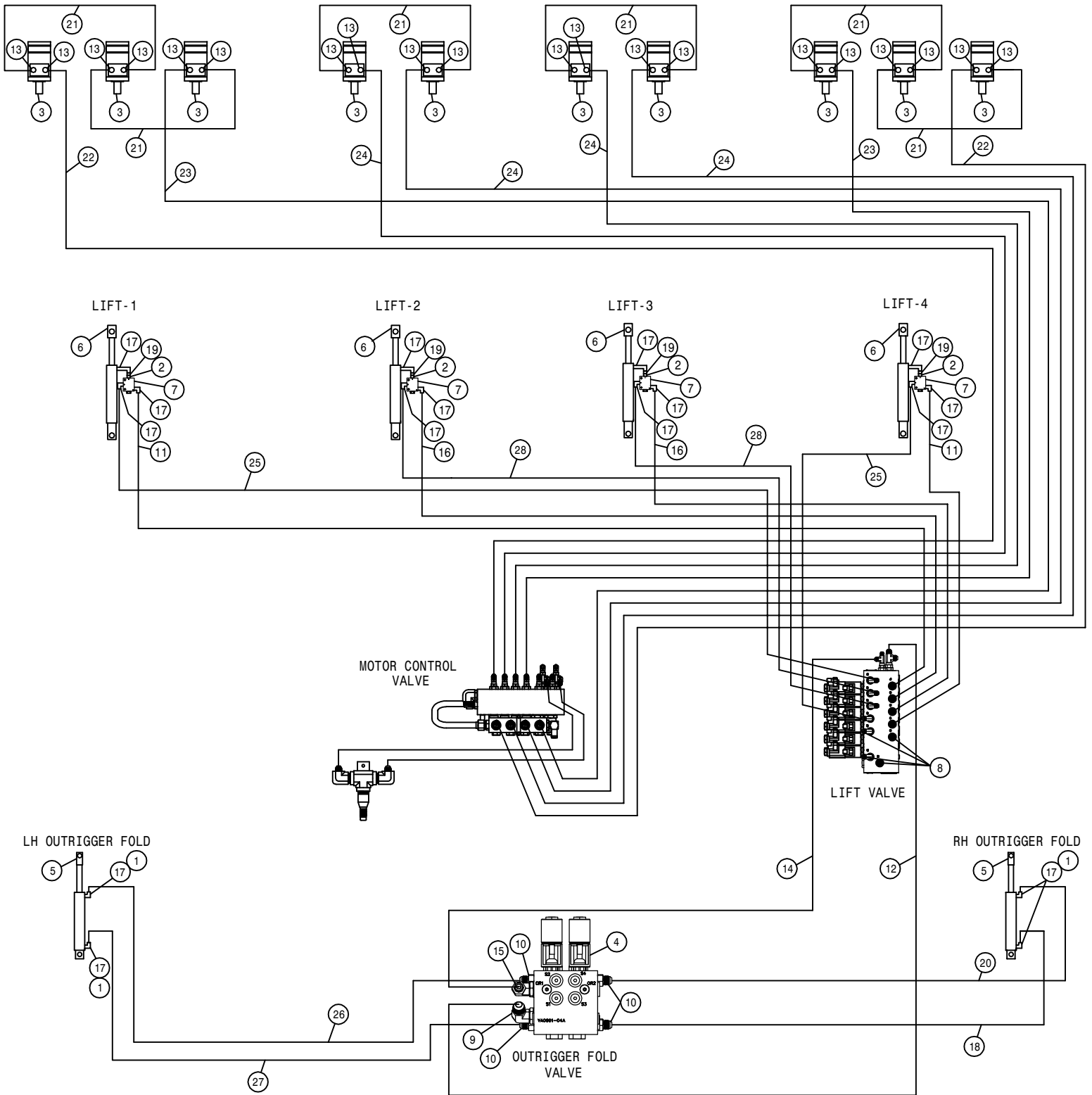

204SP 10R QUAD 4L LS HYD DIAG 2014  
REFERENCE DRAWING NO. 499301

DET.	QTY	PART NO.	DESCRIPTION	DET.	QTY	PART NO.	DESCRIPTION
1	4	618731	9/16JIC .025 ORIFICE ADPTR	15	1	618115	9/16MJIC-90-3/4MOR LBO
2	4	618668	9/16FJIC SWIV-9/16MOR ADPTR	16	2	616861	04-451TC-06FJX-06FJX90-88 H/A
3	10	610547	HYD MOTOR 4.5CI 1IN SHFT	17	16	618119	9/16MJIC-90-9/16MOR LBO
4	1	606249	MANIFOLD,TRD ADJ PWRSYS	18	1	616205	04-482TC-06FJX-06FJX-117 H/A
5	2	621520	HYD CYL, 2.00 X 10.00 X 1.000	19	4	618732	9/16JIC .031 ORIFICE ADPTR
6	4	621564	HYD CYL,2.00 X 11.00 X 1.50 1W	20	1	614152	04-482TC-06FJX-06FJX-114 H/A
7	4	607565	CHECK VLV,PILOT TO OPEN, SUN	21	6	616025	08-482TC-08FJX-08FJX-50 H/A
8	4	618531	9/16FJIC CAP NUT	22	2	614387	08-482TC-08FJX-08FJX-267 H/A
9	1	618241	3/4MJIC-90-3/4MOR LBO	23	2	614384	08-482TC-08FJX-08FJX-237 H/A
10	4	618126	9/16MJIC-9/16MOR ADPTR	24	4	616168	08-482TC-08FJX-08FJX-139 H/A
11	2	616868	04-451TC-06FJX-06FJX90-205 H/A	25	2	614098	04-482TC-06FJX-06FJX-201 H/A
12	1	616505	08-451TC-08FJX-08FJX90-24 H/A	26	1	615727	04-482TC-06FJX-06FJX-75 H/A
13	20	618327	3/4MJIC-7/8MOR ADPTR	27	1	614077	04-482TC-06FJX-06FJX-88 H/A
14	1	616117	06-451TC-06FJX-06FJX-17 H/A	28	2	615729	04-482TC-06FJX-06FJX-84 H/A

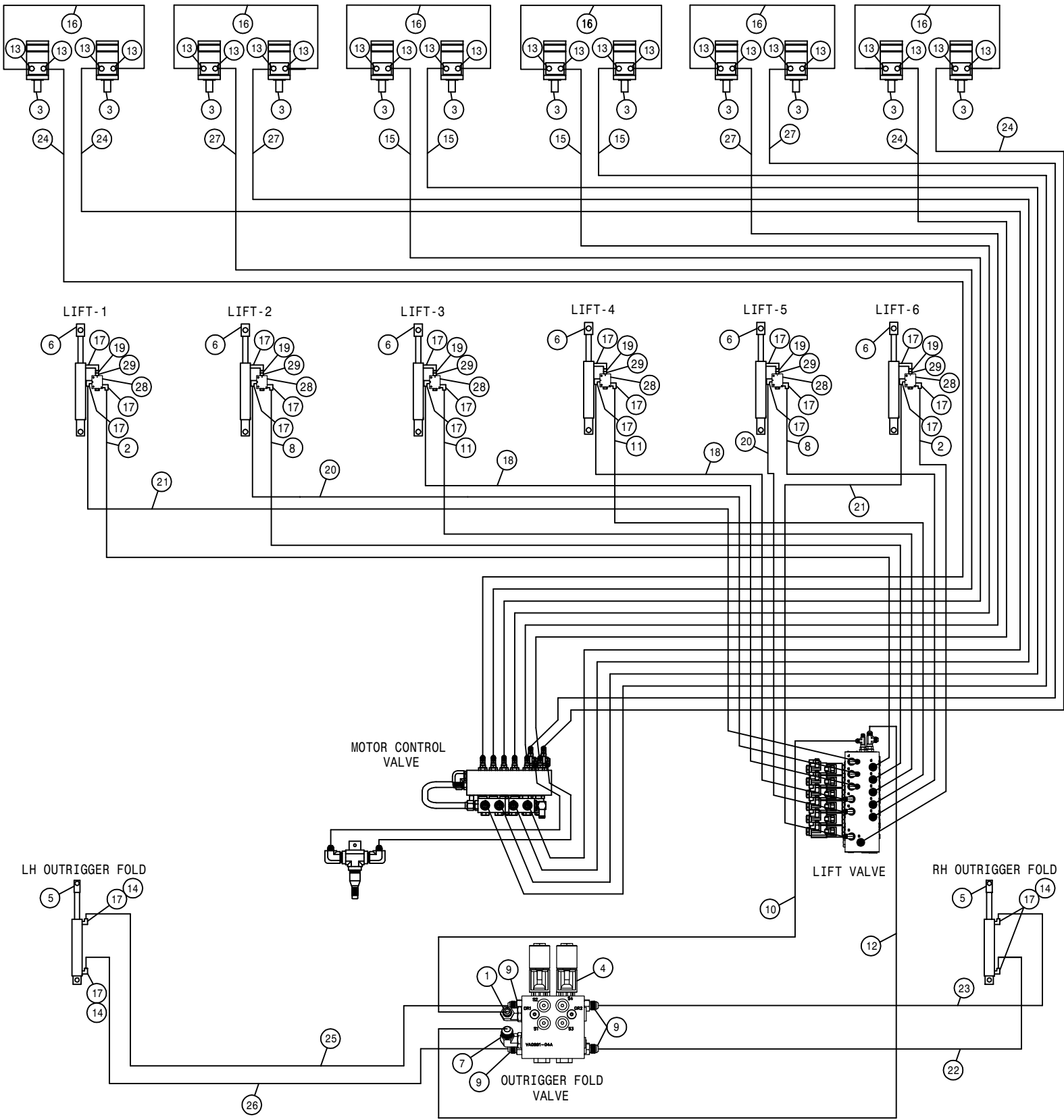

204SP 12R QUAD 6L LS HYD DIAG 2014  
REFERENCE DRAWING NO. 499302

DET.	QTY	PART NO.	DESCRIPTION	DET.	QTY	PART NO.	DESCRIPTION	
1	1	618115	9/16MJIC-90-3/4MOR LBO	16	6	616025	08-482TC-08FJX-08FJX-50	H/A
2	2	616871	04-451TC-06FJX-06FJX90-262 H/A	17	22	618119	9/16MJIC-90-9/16MOR LBO	
3	12	610547	HYD MOTOR 4.5CI 1IN SHFT	18	2	615729	04-482TC-06FJX-06FJX-84	H/A
4	1	606249	MANIFOLD,TRD ADJ PWRSYS	20	2	611262	04-482TC-06FJX-06FJX-182	H/A
5	2	621520	HYD CYL, 2.00 X 10.00 X 1.000	21	2	614377	04-482TC-06FJX-06FJX-258	H/A
6	6	621564	HYD CYL,2.00 X 11.00 X 1.50 1W	22	1	616205	04-482TC-06FJX-06FJX-117	H/A
7	1	618241	3/4MJIC-90-3/4MOR LBO	23	1	614152	04-482TC-06FJX-06FJX-114	H/A
8	2	616867	04-451TC-06FJX-06FJX90-186 H/A	24	4	616170	08-482TC-08FJX-08FJX-295	H/A
9	4	618126	9/16MJIC-9/16MOR ADPTR	25	1	615727	04-482TC-06FJX-06FJX-75	H/A
10	1	616117	06-451TC-06FJX-06FJX-17 H/A	26	1	614077	04-482TC-06FJX-06FJX-88	H/A
11	2	616861	04-451TC-06FJX-06FJX90-88 H/A	27	4	614384	08-482TC-08FJX-08FJX-237	H/A
12	1	616505	08-451TC-08FJX-08FJX90-24 H/A	28	6	607565	CHECK VLV,PILOT TO OPEN, SUN	
13	24	618327	3/4MJIC-7/8MOR ADPTR	29	6	618732	9/16JIC .031 ORIFICE ADPTR	
14	4	618731	9/16JIC .025 ORIFICE ADPTR	29	6	618733	9/16JIC .042 ORIFICE ADPTR	
15	4	616168	08-482TC-08FJX-08FJX-139 H/A					

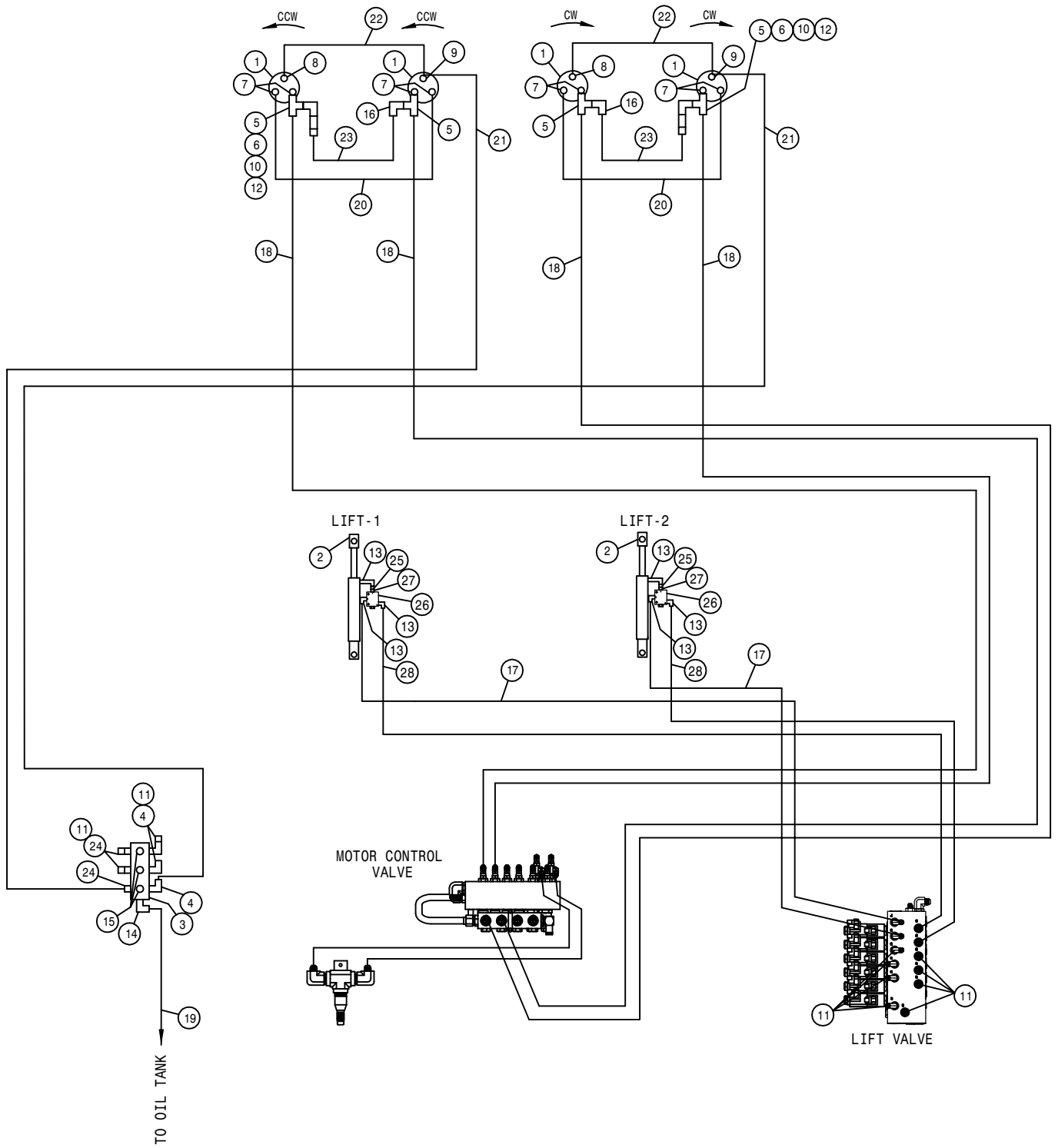

204 4R CUTTER 2L LS HYD DIAG 2014  
REFERENCE DRAWING NO. 499306

DET.	QTY	PART NO.	DESCRIPTION	DET.	QTY	PART NO.	DESCRIPTION
1	4	610755	BARNES HYD MOTOR, D-SERIES 01	15	3	611159	3/4MOR PLUG, HEX HEAD
2	2	621564	HYD CYL, 2.00 X 11.00 X 1.50 1W	16	2	618609	3/4MJIC-90-3/4FJIC SWIV LBO
3	1	606021	HYD RETURN MANIF, 3/4FOR, 9-PORT	17	2	615729	04-482TC-06FJX-06FJX-84 H/A
4	3	618115	9/16MJIC-90-3/4MOR LBO	18	4	616168	08-482TC-08FJX-08FJX-139 H/A
5	4	618451	3/4FJIC SW RUN TEE-3/4MJIC	19	1	601555	HOSE, 3/4 X 150 1FBR-1SPI
6	2	618620	3/4FJX-90-1/2MNPT ADPTR	20	2	614368	08-482TC-08FJX-08FJX-60 H/A
7	8	611125	3/4MJIC-3/4MOR ADPTR	21	2	611202	04-482TC-06FJX-06FJX-136 H/A
8	2	618530	9/16MJIC-1/8MNPT ADPTR	22	2	616422	04-482TC-06FJX-06FJX90-56 H/A
9	2	618546	1/8MNPT RUN TEE-9/16MJIC	23	2	616025	08-482TC-08FJX-08FJX-50 H/A
10	2	690338	LINE CHECK VALVE HYD .50NPT	24	1	618109	9/16MJIC-3/4MOR ADPTR
11	12	618531	9/16FJIC CAP NUT	25	2	618732	9/16JIC .031 ORIFICE ADPTR
12	2	611147	3/4MJIC-1/2MNPT ADPTR	26	2	607565	CHECK VLV, PILOT TO OPEN, SUN
13	6	618119	9/16MJIC-90-9/16MOR LBO	27	2	618668	9/16FJIC SWIV-9/16MOR ADPTR
14	1	618118	3/4 HOSE BARB-90-1 1/16MOR	28	2	616861	04-451TC-06FJX-06FJX90-88 H/A

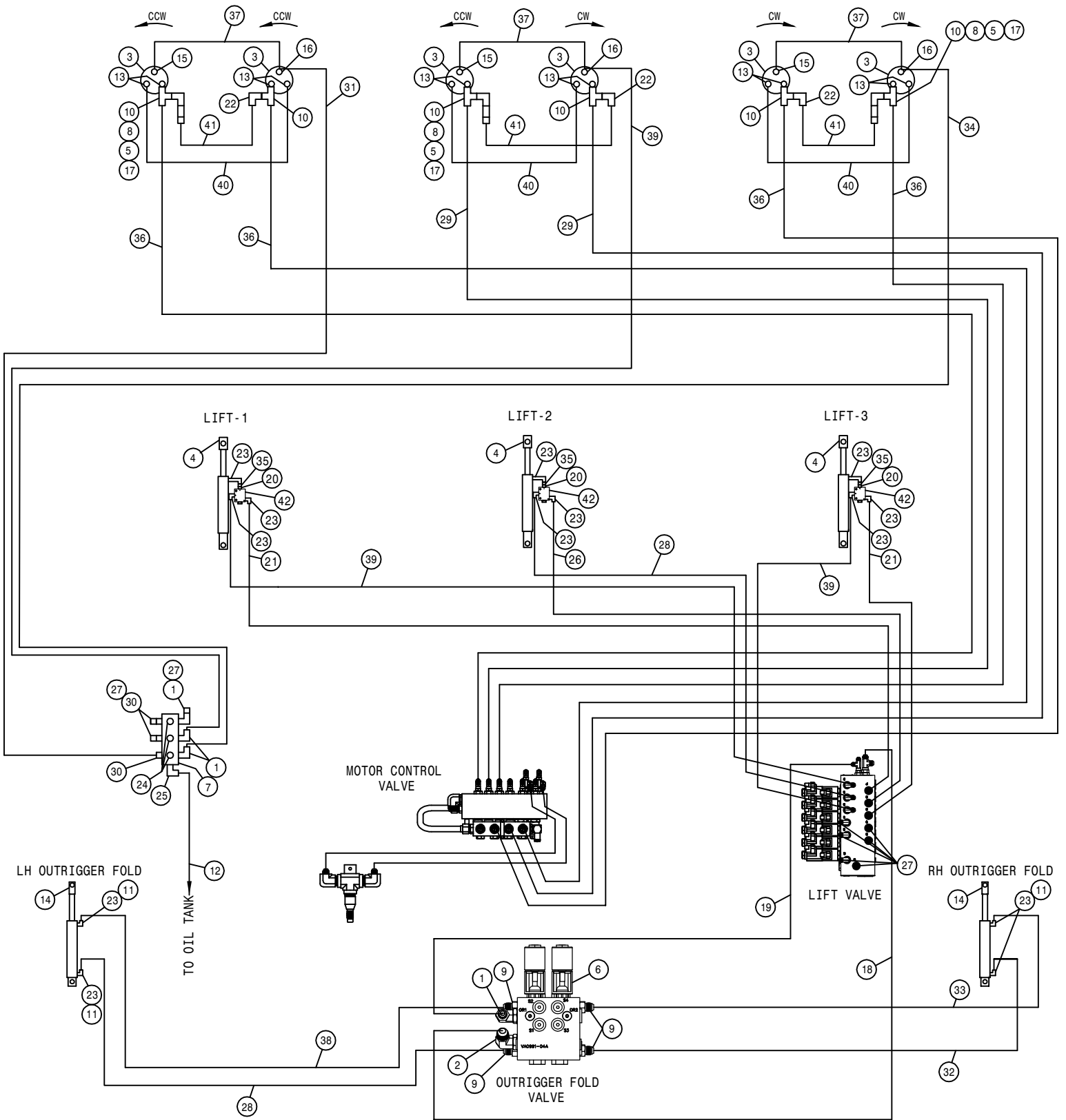



204SP 6R CUTTER 3L LS HYD SCHEM 2011  
REFERENCE DRAWING NO. 499307

DET.	QTY	PART NO.	DESCRIPTION	DET.	QTY	PART NO.	DESCRIPTION
1	4	618115	9/16MJIC-90-3/4MOR LBO	22	3	618609	3/4MJIC-90-3/4FJIC SWIV LBO
2	1	618241	3/4MJIC-90-3/4MOR LBO	23	13	618119	9/16MJIC-90-9/16MOR LBO
3	6	610755	BARNES HYD MOTOR, D-SERIES 01	24	3	611159	3/4MOR PLUG, HEX HEAD
4	3	621564	HYD CYL, 2.00 X 11.00 X 1.50 1W	25	1	618118	3/4 HOSE BARB-90-1 1/16MOR
5	3	690338	LINE CHECK VALVE HYD .50NPT	26	1	616862	04-451TC-06FJX-06FJX90-92 H/A
6	1	606249	MANIFOLD, TRD ADJ PWRSYS	27	9	618531	9/16FJIC CAP NUT
7	1	606021	HYD RETURN MANIF, 3/4FOR, 9-PORT	28	2	614077	04-482TC-06FJX-06FJX-88 H/A
8	3	618620	3/4FJX-90-1/2MNPT ADPTR	29	2	614688	08-482TC-08FJX-08FJX-108 H/A
9	4	618126	9/16MJIC-9/16MOR ADPTR	30	3	618109	9/16MJIC-3/4MOR ADPTR
10	6	618451	3/4FJIC SW RUN TEE-3/4MJIC	31	1	614102	04-482TC-06FJX-06FJX-191 H/A
11	4	618731	9/16JIC .025 ORIFICE ADPTR	32	1	616205	04-482TC-06FJX-06FJX-117 H/A
12	1	601555	HOSE, 3/4 X 150 1FBR-1SPI	33	2	614152	04-482TC-06FJX-06FJX-114 H/A
13	12	611125	3/4MJIC-3/4MOR ADPTR	34	1	611210	04-482TC-06FJX-06FJX-156 H/A
14	2	621520	HYD CYL, 2.00 X 10.00 X 1.000	35	3	618732	9/16JIC .031 ORIFICE ADPTR
15	3	618530	9/16MJIC-1/8MNPT ADPTR	36	4	614690	08-482TC-08FJX-08FJX-192 H/A
16	3	618546	1/8MNPT RUN TEE-9/16MJIC	37	3	616422	04-482TC-06FJX-06FJX90-56 H/A
17	3	611147	3/4MJIC-1/2MNPT ADPTR	38	1	615727	04-482TC-06FJX-06FJX-75 H/A
18	1	616502	08-451TC-08FJX-08FJX-20 H/A	39	2	614101	04-482TC-06FJX-06FJX-133 H/A
19	1	616117	06-451TC-06FJX-06FJX-17 H/A	40	3	614368	08-482TC-08FJX-08FJX-60 H/A
20	3	618668	9/16FJIC SWIV-9/16MOR ADPTR	41	3	616025	08-482TC-08FJX-08FJX-50 H/A
21	2	616864	04-451TC-06FJX-06FJX90-137 H/A	42	3	607565	CHECK VLV, PILOT TO OPEN, SUN

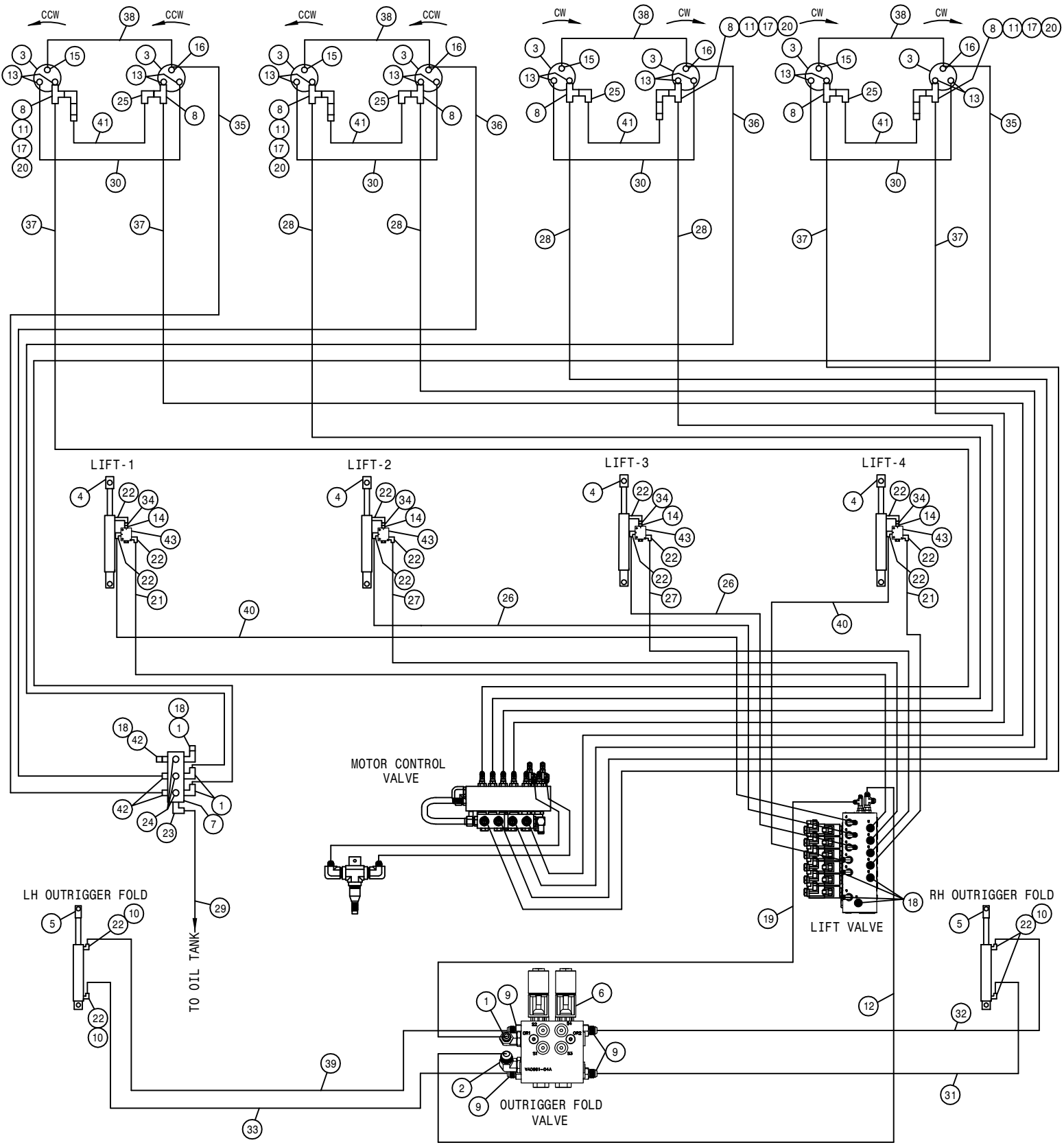

204SP 8R CUTTER 4L LS HYD DIAG 2014  
REFERENCE DRAWING NO. 499309

DET.	QTY	PART NO.	DESCRIPTION	DET.	QTY	PART NO.	DESCRIPTION
1	4	618115	9/16MJIC-90-3/4MOR LBO	23	1	618118	3/4 HOSE BARB-90-1 1/16MOR
2	1	618241	3/4MJIC-90-3/4MOR LBO	24	3	611159	3/4MOR PLUG, HEX HEAD
3	8	610755	BARNES HYD MOTOR, D-SERIES 01	25	4	618609	3/4MJIC-90-3/4FJIC SWIV LBO
4	4	621564	HYD CYL, 2.00 X 11.00 X 1.50 1W	26	2	615729	04-482TC-06FJX-06FJX-84 H/A
5	2	621520	HYD CYL, 2.00 X 10.00 X 1.000	27	2	616861	04-451TC-06FJX-06FJX90-88 H/A
6	1	606249	MANIFOLD, TRD ADJ PWRSYS	28	4	616168	08-482TC-08FJX-08FJX-139 H/A
7	1	606021	HYD RETURN MANIF, 3/4FOR, 9-PORT	29	1	601555	HOSE, 3/4 X 150 1FBR-1SPI
8	8	618451	3/4FJIC SW RUN TEE-3/4MJIC	30	4	614368	08-482TC-08FJX-08FJX-60 H/A
9	4	618126	9/16MJIC-9/16MOR ADPTR	31	1	616205	04-482TC-06FJX-06FJX-117 H/A
10	4	618731	9/16JIC .025 ORIFICE ADPTR	32	1	614152	04-482TC-06FJX-06FJX-114 H/A
11	4	618620	3/4FJX-90-1/2MNPT ADPTR	33	1	614077	04-482TC-06FJX-06FJX-88 H/A
12	1	616505	08-451TC-08FJX-08FJX90-24 H/A	34	4	618732	9/16JIC .031 ORIFICE ADPTR
13	16	611125	3/4MJIC-3/4MOR ADPTR	35	2	614303	04-482TC-06FJX-06FJX-234 H/A
14	4	618668	9/16FJIC SWIV-9/16MOR ADPTR	36	2	611202	04-482TC-06FJX-06FJX-136 H/A
15	4	618530	9/16MJIC-1/8MNPT ADPTR	37	4	614384	08-482TC-08FJX-08FJX-237 H/A
16	4	618546	1/8MNPT RUN TEE-9/16MJIC	38	4	616422	04-482TC-06FJX-06FJX90-56 H/A
17	4	690338	LINE CHECK VALVE HYD .50NPT	39	1	615727	04-482TC-06FJX-06FJX-75 H/A
18	6	618531	9/16FJIC CAP NUT	40	2	611262	04-482TC-06FJX-06FJX-182 H/A
19	1	616117	06-451TC-06FJX-06FJX-17 H/A	41	4	616025	08-482TC-08FJX-08FJX-50 H/A
20	4	611147	3/4MJIC-1/2MNPT ADPTR	42	3	618109	9/16MJIC-3/4MOR ADPTR
21	2	616867	04-451TC-06FJX-06FJX90-186 H/A	43	4	607565	CHECK VLV, PILOT TO OPEN, SUN
22	16	618119	9/16MJIC-90-9/16MOR LBO				

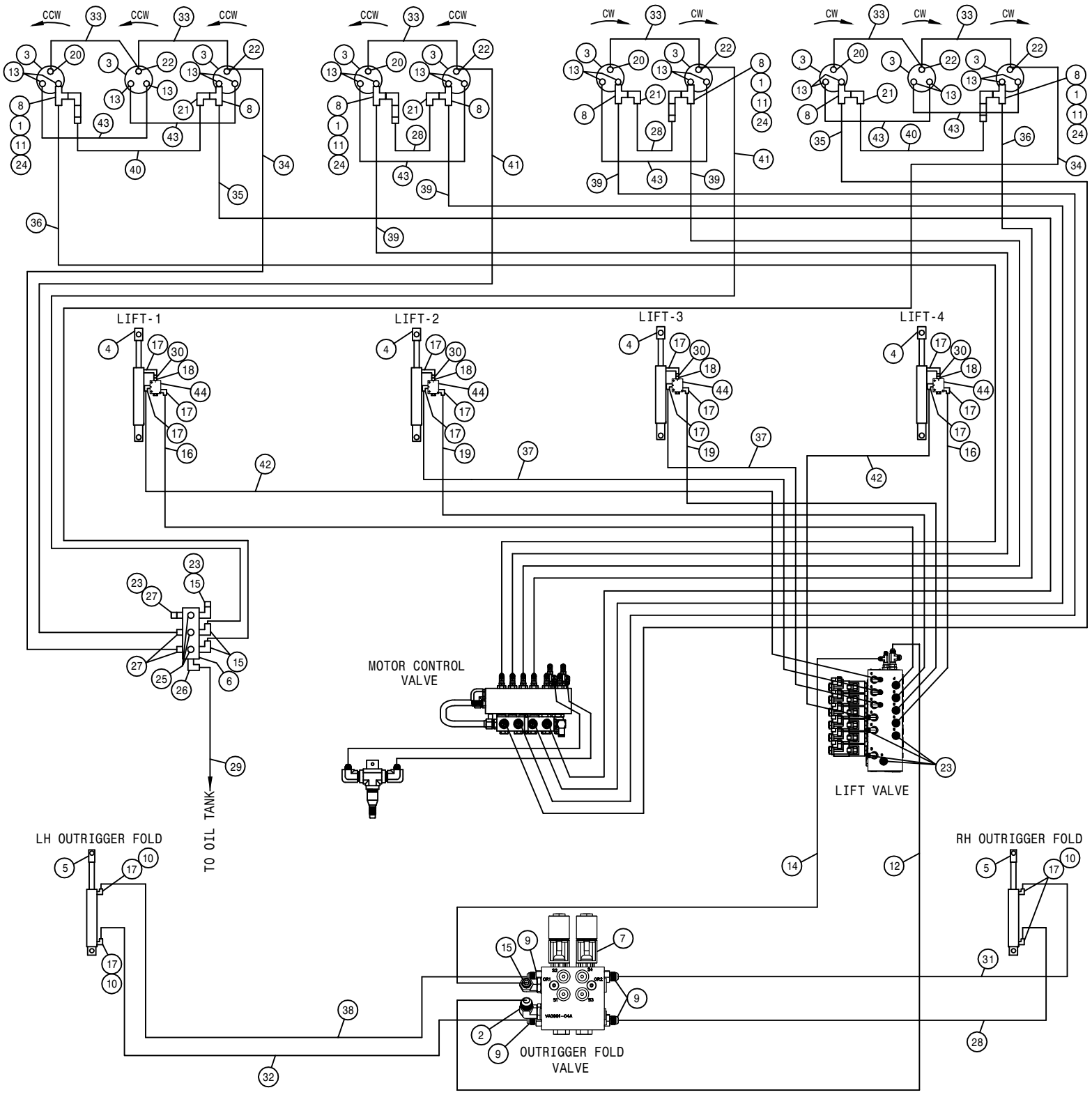

204SP 10R CUTR 4L LS HYD DIAG 2014  
REFERENCE DRAWING NO. 499312

DET.	QTY	PART NO.	DESCRIPTION	DET.	QTY	PART NO.	DESCRIPTION
1	4	618620	3/4FJX-90-1/2MNPT ADPTR	23	6	618531	9/16FJIC CAP NUT
2	1	618241	3/4MJIC-90-3/4MOR LBO	24	4	611147	3/4MJIC-1/2MNPT ADPTR
3	10	610755	BARNES HYD MOTOR, D-SERIES 01	25	3	611159	3/4MOR PLUG, HEX HEAD
4	4	621564	HYD CYL, 2.00 X 11.00 X 1.50 1W	26	1	618118	3/4 HOSE BARB-90-1 1/16MOR
5	2	621520	HYD CYL, 2.00 X 10.00 X 1.000	27	3	618109	9/16MJIC-3/4MOR ADPTR
6	1	606021	HYD RETURN MANIF, 3/4FOR, 9-PORT	28	3	616025	08-482TC-08FJX-08FJX-50 H/A
7	1	606249	MANIFOLD, TRD ADJ PWRSYS	29	1	601555	HOSE, 3/4 X 150 1FBR-1SPI
8	8	618451	3/4FJIC SW RUN TEE-3/4MJIC	30	1	618732	9/16JIC .031 ORIFICE ADPTR
9	4	618126	9/16MJIC-9/16MOR ADPTR	31	1	614152	04-482TC-06FJX-06FJX-114 H/A
10	4	618731	9/16JIC .025 ORIFICE ADPTR	32	1	614077	04-482TC-06FJX-06FJX-88 H/A
11	4	690338	LINE CHECK VALVE HYD .50NPT	33	6	616422	04-482TC-06FJX-06FJX90-56 H/A
12	1	616505	08-451TC-08FJX-08FJX90-24 H/A	34	2	614377	04-482TC-06FJX-06FJX-258 H/A
13	20	611125	3/4MJIC-3/4MOR ADPTR	35	2	614384	08-482TC-08FJX-08FJX-237 H/A
14	1	616117	06-451TC-06FJX-06FJX-17 H/A	36	2	614387	08-482TC-08FJX-08FJX-267 H/A
15	4	618115	9/16MJIC-90-3/4MOR LBO	37	2	615729	04-482TC-06FJX-06FJX-84 H/A
16	2	616868	04-451TC-06FJX-06FJX90-205 H/A	38	1	615727	04-482TC-06FJX-06FJX-75 H/A
17	16	618119	9/16MJIC-90-9/16MOR LBO	39	4	616168	08-482TC-08FJX-08FJX-139 H/A
18	4	618668	9/16FJIC SWIV-9/16MOR ADPTR	40	2	616031	08-482TC-08FJX-08FJX-83 H/A
19	2	616861	04-451TC-06FJX-06FJX90-88 H/A	41	2	611202	04-482TC-06FJX-06FJX-136 H/A
20	4	618530	9/16MJIC-1/8MNPT ADPTR	42	2	614098	04-482TC-06FJX-06FJX-201 H/A
21	4	618609	3/4MJIC-90-3/4FJIC SWIV LBO	43	6	614368	08-482TC-08FJX-08FJX-60 H/A
22	6	618546	1/8MNPT RUN TEE-9/16MJIC	44	4	607565	CHECK VLV, PILOT TO OPEN, SUN

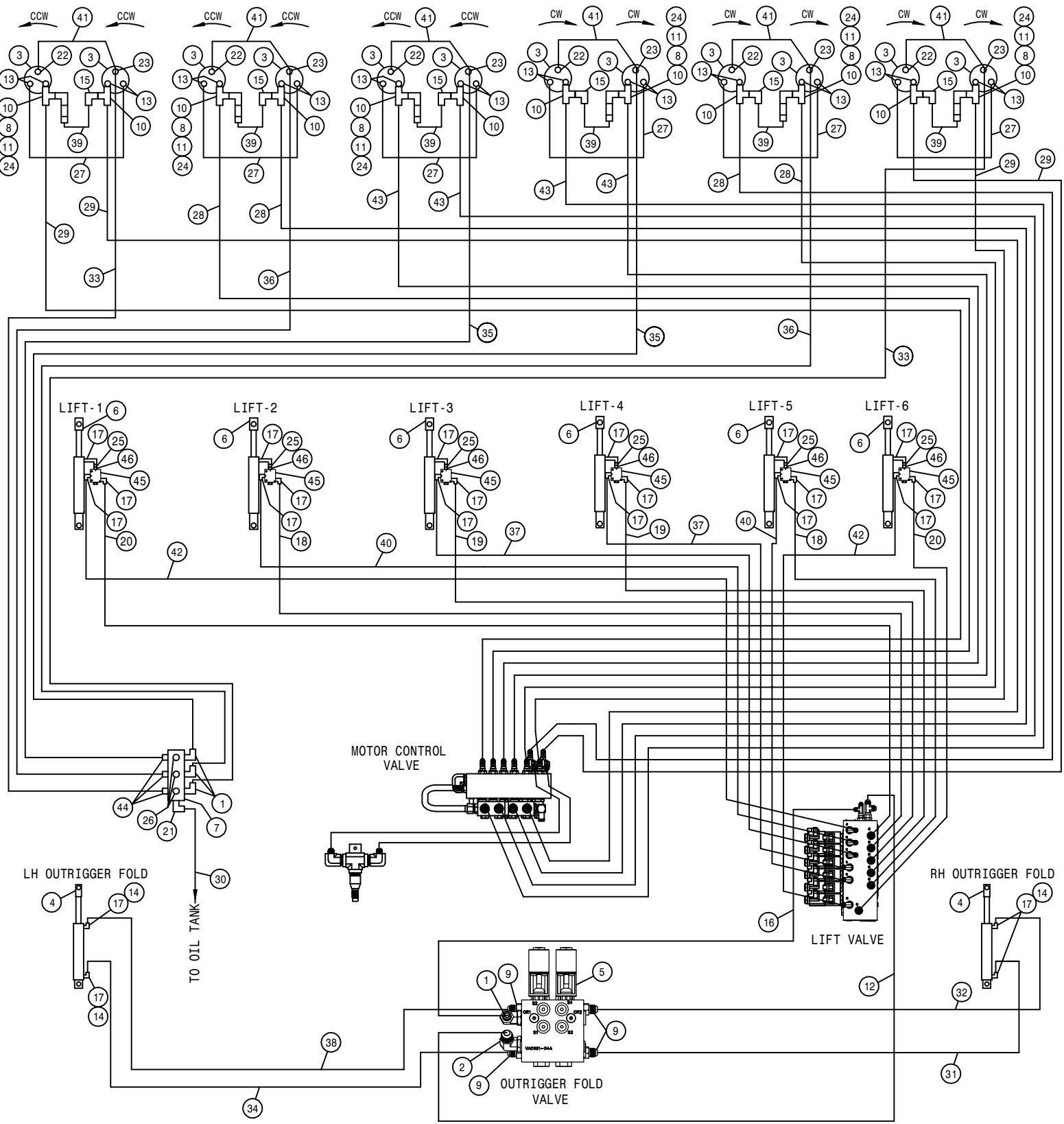

204SP 12R CUTR 6L LS HYD DIAG 2014  
REFERENCE DRAWING NO. 499313

DET.	QTY	PART NO.	DESCRIPTION	DET.	QTY	PART NO.	DESCRIPTION
1	4	618115	9/16MJIC-90-3/4MOR LBO	24	6	611147	3/4MJIC-1/2MNPT ADPTR
2	1	618241	3/4MJIC-90-3/4MOR LBO	25	6	618732	9/16JIC .031 ORIFICE ADPTR
3	12	610755	BARNES HYD MOTOR, D-SERIES 01	26	3	611159	3/4MOR PLUG, HEX HEAD
4	2	621520	HYD CYL, 2.00 X 10.00 X 1.000	27	6	614368	08-482TC-08FJX-08FJX-60 H/A
5	1	606249	MANIFOLD,TRD ADJ PWRSYS	28	4	614384	08-482TC-08FJX-08FJX-237 H/A
6	6	621564	HYD CYL,2.00 X 11.00 X 1.50 1W	29	4	616170	08-482TC-08FJX-08FJX-295 H/A
7	1	606021	HYD RETURN MANIF,3/4FOR,9-PORT	30	1	601555	HOSE, 3/4 X 150 1FBR-1SPI
8	6	618620	3/4FJX-90-1/2MNPT ADPTR	31	1	616205	04-482TC-06FJX-06FJX-117 H/A
9	4	618126	9/16MJIC-9/16MOR ADPTR	32	1	614152	04-482TC-06FJX-06FJX-114 H/A
10	12	618451	3/4FJIC SW RUN TEE-3/4MJIC	33	2	614504	04-482TC-06FJX-06FJX-301 H/A
11	6	690338	LINE CHECK VALVE HYD .50NPT	34	1	614077	04-482TC-06FJX-06FJX-88 H/A
12	1	616505	08-451TC-08FJX-08FJX90-24 H/A	35	2	611202	04-482TC-06FJX-06FJX-136 H/A
13	24	611125	3/4MJIC-3/4MOR ADPTR	36	2	614303	04-482TC-06FJX-06FJX-234 H/A
14	4	618731	9/16JIC .025 ORIFICE ADPTR	37	2	615729	04-482TC-06FJX-06FJX-84 H/A
15	6	618609	3/4MJIC-90-3/4FJIC SWIV LBO	38	1	615727	04-482TC-06FJX-06FJX-75 H/A
16	1	616117	06-451TC-06FJX-06FJX-17 H/A	39	6	616025	08-482TC-08FJX-08FJX-50 H/A
17	22	618119	9/16MJIC-90-9/16MOR LBO	40	2	611262	04-482TC-06FJX-06FJX-182 H/A
18	2	616867	04-451TC-06FJX-06FJX90-186 H/A	41	6	616422	04-482TC-06FJX-06FJX90-56 H/A
19	2	616861	04-451TC-06FJX-06FJX90-88 H/A	42	2	614377	04-482TC-06FJX-06FJX-258 H/A
20	2	616871	04-451TC-06FJX-06FJX90-262 H/A	43	4	616168	08-482TC-08FJX-08FJX-139 H/A
21	1	618118	3/4 HOSE BARB-90-1 1/16MOR	44	3	618109	9/16MJIC-3/4MOR ADPTR
22	6	618530	9/16MJIC-1/8MNPT ADPTR	45	6	607565	CHECK VLV,PILOT TO OPEN, SUN
23	6	618546	1/8MNPT RUN TEE-9/16MJIC	46	6	618668	9/16FJIC SWIV-9/16MOR ADPTR

## ABBREVIATIONS

A/C - AIR CONDITIONER	MT - MOUNT
ADPTR - ADAPTER	MTR - MOTOR
AGI - AGITATOR	P/N - PART NUMBER
ALT - ALTERNATOR	PLT - PLATE
ASSY - ASSEMBLY	QTY - QUANTITY
BRKT - BRACKET	RED - REDUCER
DET - DETAIL	REF - REFERENCE
DISPL - DISPLACEMENT	REST - RESTRICTOR
EL - ELBOW	REQ - REQUIRED
EXT - EXTENSION	SHFT - SHAFT
FLO - FLOW	SOL - SOLUTION
FNPT - FEMALE NATIONAL PIPE THREAD	STRG - STEERING
FOR - FEMALE O-RING	ST - STREET
FRT - FRONT	SV - STANDARD VOLUME
HV - HI-VOLUME	SWIV - SWIVEL
HYD - HYDRAULIC	UNC - UNIFIED NATIONAL COURSE
HYDRO - HYDROSTATIC	UNF - UNIFIED NATIONAL FINE
LG - LONG	V - VOLT
LWR - LOWER	W/ - WITH
MJIC - MALE J.I.C.	WHL - WHEEL
MOR - MALE O-RING	WLD - WELDMENT



-A-

ABBREVIATIONS.....108  
 ACTUATOR.....75  
 AIR BAG.....35,36,37,38  
 AIR CLEANER.....6  
   CAP.....6  
   FILTER.....6  
   HOSE.....6  
 ALARM, BACKUP.....9  
 A/C, CAB.....58  
   COMPRESSOR.....8  
   FILTER.....58

-B-

BACKUP ALARM.....9  
 BATTERY.....8  
   CABLE.....9  
   SWITCH.....9  
 BEACON.....55,56  
 BELT, ENGINE.....4  
 BOX, DEPTH COMMAND.....53  
 BRAKE VALVE.....23

-C-

CAB.....56  
   A/C.....58  
   DOOR.....57  
   GLASS.....56  
   MOUNT.....44  
 CABLE, BATTERY.....9  
 CANOPY.....55  
 CANTRAK DISPLAY.....52  
 CHOPPER, MALE ROW.....80,81  
 COMPRESSOR, A/C.....8  
 CONDENSOR, A/C.....8  
 CONSOLE.....47  
 CONTROL LEVER.....50  
 CUP HOLDER.....48  
 CUTTER CASE DRAIN MANIFOLD.....28  
 CUTTER HEAD.....77,78  
 CYLINDERS,  
   FOLD.....31,32  
   LIFT.....70,71,72,73,74  
   STEERING.....33,34

-D-

DEPTH COMMAND BOX.....53  
 DIAGRAM, HYDRAULIC.....84  
 DOOR, CAB.....57  
 DRYER, A/C.....8  
 DUMP VALVE.....21

-E-

E-STOP.....51  
 ENGINE.....4,5  
   HARNESS.....9  
   ISOLATOR.....4

-F-

FAN.....4  
 FILTER,  
   AIR CLEANER.....6  
   A/C.....58  
   HYDRAULIC.....17,18  
 FIRE EXTINGUISHER.....44  
 FLASHER.....55  
 FLOW DIVIDER.....22  
 FOAM, CAB.....59  
 FOLD CYLINDER.....31,32  
 FOLD VALVE, OUTRIGGER.....29  
 FUEL SELECTOR VALVE.....41  
 FUEL TANK.....40  
   SENSOR.....40

-G-

GLASS, CAB.....56

-H-

HOSE, RADIATOR.....7  
 HUB, TORQUE.....35,36,37,38  
 HYDRAULIC  
   DIAGRAM.....84  
   FILTER.....17,18,21  
   HOSING.....10,11,12,13  
   TANK.....17  
 HYDROSTATIC PUMP.....15

-I-

ISOLATOR, ENGINE.....4,5

-L-

LADDER.....42,43  
 LEG.....35,36,37,38  
 LIFT ASSEMBLY.....70,71,72,73  
 LIFT VALVE.....26  
 LIGHTS.....55,56  
 LOOP FLUSHING VALVE.....16  
 LS DISPLAY.....47  
 LS SENSOR.....75

-M-

MAINFRAME.....63  
 MALE ROW CHOPPER.....80,81  
 MANIFOLD, CUTTER CASE DRAIN.....26  
 MIRROR.....55,56  
 MODULE, DETASSLER.....49  
 MOTOR,  
   CONTROL VALVE.....24  
   STEERING.....46  
   WHEEL.....35,36,37,38  
 MOUNT, CAB.....44  
 MUFFLER.....5

-O-

OIL COOLER.....14  
 OPERATOR STATION.....44  
 OUTRIGGER FOLD VALVE.....29,30

-P-

PULLER, QUAD.....76  
 POSITRACTION VALVE.....19,20  
 PUMP, HYROSTATIC.....15

-Q-

QUAD PULLER.....76

-R-

RADIATOR.....7  
   HOSE.....7  
 RADIO.....58  
 RIM.....39  
 ROOF.....56  
 ROPS.....55

-S-

SEAT.....45  
 SENSOR, FUEL TANK.....40  
 SERVICE PLATFORM.....42,43  
 SHEET METAL.....60,61,62  
 SHIELDS.....62  
 SHIFT VALVE.....23  
 SMV SIGN.....61  
 STEERING  
   COLUMN.....46  
   CYLINDER.....33,34  
   MOTOR.....46  
   WHEEL.....46  
 SWITCH, BATTERY.....9

-T-

TANK, HYDRAULIC.....18  
 TIRE.....35  
 TOOLBAR.....65  
 TORQ HUB.....35,36,37,38

-V-

VALVE,  
   BRAKE.....23  
   DUMP.....21  
   FUEL SELECTOR.....41  
   LIFT.....26  
   LOOP FLUSHING.....16  
   MOTOR CONTROL.....24  
   POSITRACTION.....19,20  
   SHIFT.....23

-W-

WEIGHTS.....64  
 WHEEL MOTOR.....35,36,37,38  
 WIPER.....56

# Notes:

# Notes: