

PARTS MANUAL
FOR
HAGIE MODEL 254 X-11 HI-TRACTOR

HAGIE MANUFACTURING COMPANY

BOX 273 CLARION, IOWA 50525 (515) 532-2861

COVERS MACHINE SERIAL NUMBERS: 037799001 thru 037799200

04-98 493189
02-08

SPRAYER IDENTIFICATION

Each Hagie sprayer is identified by means of a frame serial number. This serial number denotes the model, the year in which it was built, and the number of the sprayer. As for further identification, the engine has a serial number and the planetary hubs have identification plates that describe the type of mount and gear ratio. To insure prompt, efficient service when ordering parts or requesting service repairs from Hagie Manufacturing Company, record the serial and identification numbers in the space provided below.

NOTE: Reference to left hand and right hand used throughout this manual refers to the position when seated in the operator's seat facing forward.

SPRAYER SERIAL NUMBER

ENGINE SERIAL NUMBER

PLANETARY HUB IDENTIFICATION NUMBERS

TABLE OF CONTENTS

ENGINE ASSEMBLIES	4-6
POSITRACTION VALVE.	7-8
FLOW DIVIDER AND FLUSHING VALVE9-11
A/C AND RADIATOR.	12-13
AIR CLEANER AND EXHAUST PIPE.	14-15
LEG ASSEMBLIES.	16-17
TIRE.18
CROP GUIDE.19
TIE ROD ASSEMBLY.20
STEERING CYLINDER21
MAINFRAME ASSEMBLY.	22-23
FUEL TANKS AND OIL TANK	24-25
CAB ASSEMBLY.	26-30
INSTRUMENT PANEL ASSEMBLY31
CONSOLE ASSEMBLY.	32-35
BRAKE LEVER36
SEAT AND MONITOR BRACKET ASSEMBLY	37-38
VARIABLE FLOW CONTROL ASSEMBLY.39
SHEET METAL	40-41
LADDER AND SERVICE PLATFORM ASSEMBLY.42
BOOM CRADLE AND TANK SHIELDS.	43-44
BATTERY BOX ASSEMBLY.45
TRANSOM, BOOM AND LIFT COMPONENTS	46-54
SOLUTION SYSTEM	55-58
INJECTION PLATFORM.59
HYPRO D-230 ASSEMBLY.	60-62
6FT DROP AND BEAN 35 ASSEMBLY	63-67
WHEEL DRIVE ASSEMBLY.	68-69
DECALS.	70-71
HYDRAULIC SCHEMATIC	72-75
ELECTRICAL SCHEMATIC.	76-83
ABBREVIATIONS84
INDEX85

CUMMINS ENGINE ASSEMBLY

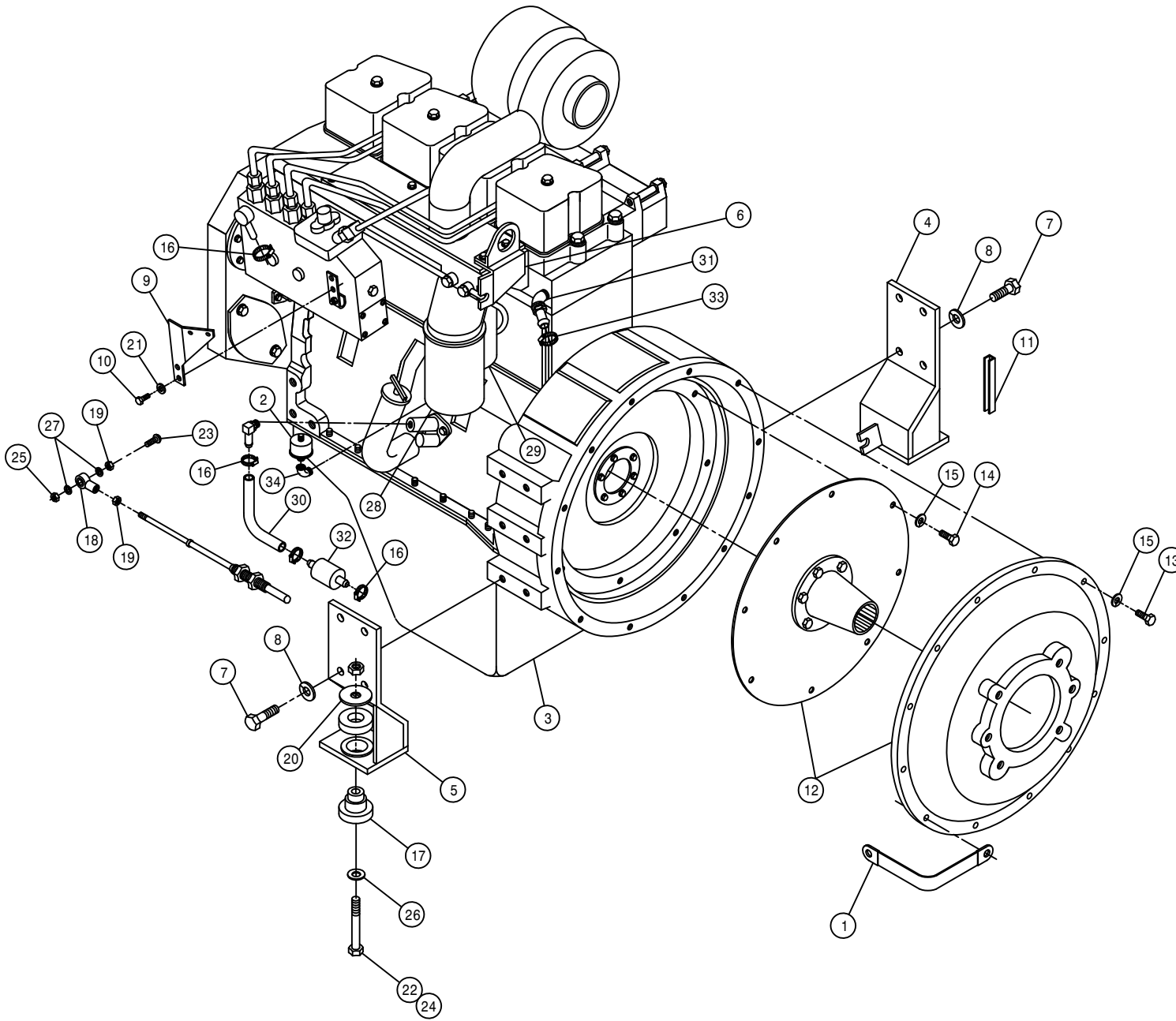

DET.	QTY	PART NO.	DESCRIPTION
	1	290107	GROUND CABLE,8" X 4GA .406LUGS
	2	291674	OIL PRESS SENDER,125PSI,1/8NPT
	3	316328	CUMM ENG,4B3.9A 110@2500
	4	316252	RH REAR ENG MT WLD, CUMM 94
	5	316253	LH REAR ENG MT WLD, CUMM 94
	6	316345	THROTTLE BRKT, 254 98
	7	473775	12MM-1.75 X 30MM HEX BOLT
	8	473784	12MM LOCK WASHER
	9	316304	THROTTLE LEVER EXT,6CYL CUMM97
	10	473826	6MM-1.00 X 16MM HEX BOLT
	11	193012	QUICKEDGE TRIM .135 TO .250
	12	800495	SUND DRIVE ASSY,2.83PILOT 14T
	13	473792	10MM-1.50 X 30MM HEX BOLT
	14	473793	10MM-1.50 X 20MM HEX BOLT
	15	473798	10MM LOCK WASHER
	16	520120	HOSE CLAMP NO 4 STAINLESS
	17	311054	RUBBER MOUNT SET, CB-2202-4
	18	473921	BALL JOINT NO 10-32 THD
	19	910027	10-32 HEX NUT
	20	311055	REBOUND WASHER FOR 311054
	21	920500	1/4 LOCK WASHER
	22	900271	1/2UNC X 3 1/4 HEX BOLT
	23	903893	10-32 X 1" SLT RD HD MACH SCR
	24	914008	1/2UNC HEX STOVER NUT
	25	914027	10-32 HEX STOVER NUT
	26	920004	1/2 SAE FLAT WASHER
	27	920510	#10 LOCK WASHER
	28	316208	FUEL FILTER, PRIMARY CUMM 92
	29	316209	FUEL FILTER, SECONDARY CUMM92
	30	601347	HOSE, 3/8 X 10 FUEL LINE
	31	503211	BLK PIPE ST EL 45DEG .50NPT
	32	316281	FUEL STRAINER, IN-LINE, DIESEL
	33	520055	HOSE CLAMP NO 12 STAINLESS
	34	500900	BLK PIPE ST EL 90DEG .125NPT

4

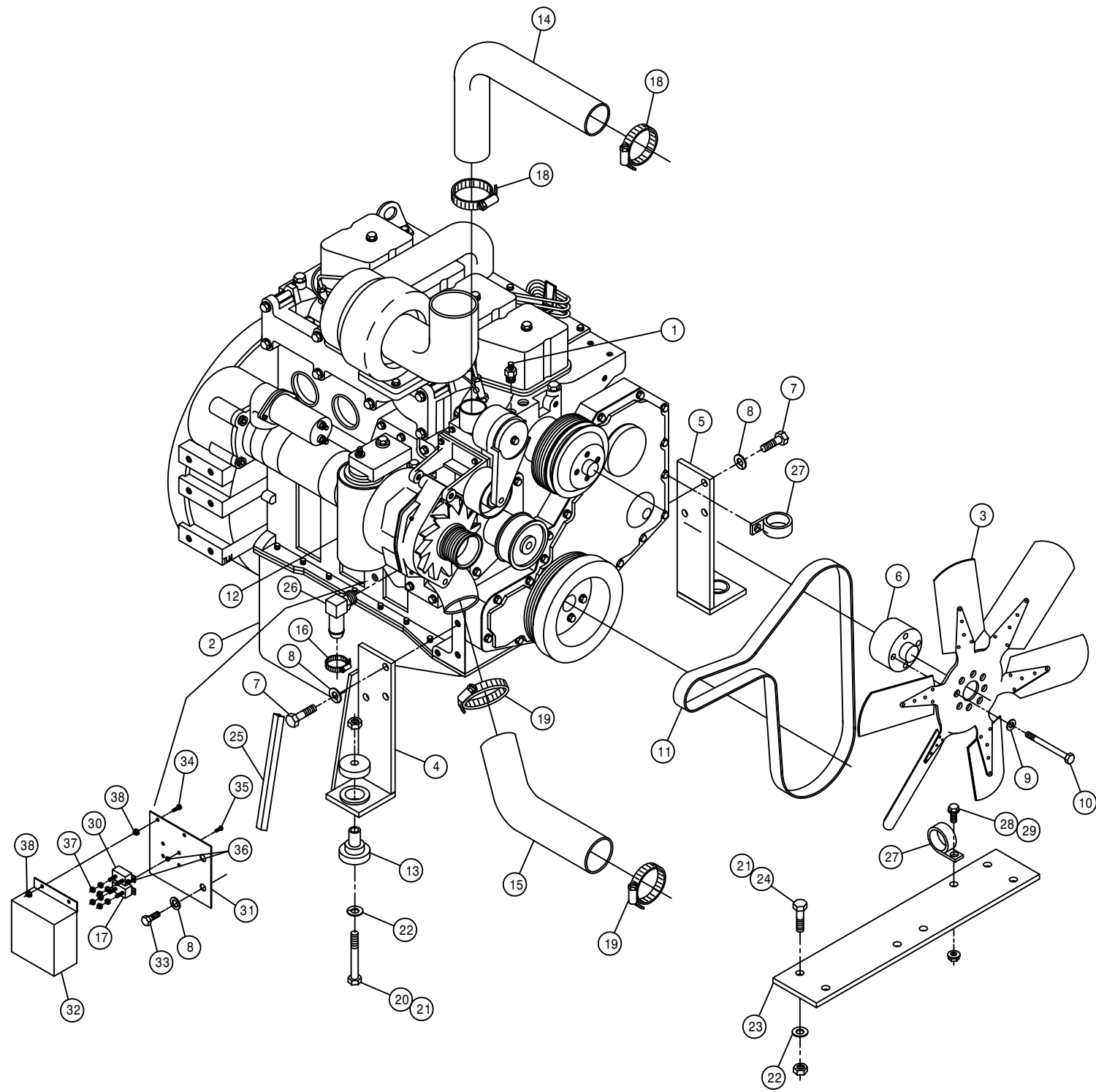

CUMMINS ENGINE ASSEMBLY

DET.	QTY	PART NO.	DESCRIPTION
1	1	314836	TEMP SENDR 280D 1/2NPT FOR GA
2	1	316328	CUMM ENG,4B3.9A 110@2500
3	1	316180	FAN, 22" 6 BLADE 30DEG 2.25PIT
4	1	316250	RH FRT ENG MT WLD, CUMM 94
5	1	316313	LH FRT ENG MT WLD, 284 CUMM 98
6	1	316199	22IN FAN SPACER CUMM 92
7	6	473775	12MM-1.75 X 30MM HEX BOLT
8	8	473784	12MM LOCK WASHER
9	4	473804	8MM LOCK WASHER
10	4	473822	8MM-1.25 X 70MM HEX BOLT
11	1	316206	POLY V BELT CUMMINS DIESEL 92
12	1	316207	LUBE FILTER CUMMINS DIESEL 92
13	2	311053	RUBBER MOUNT SET,SSB26-1000-1
14	1	314832	RADIATOR HOSE 1.75 X 19
15	1	314886	RADIATOR HOSE 2 1/4 20717
16	1	520055	HOSE CLAMP NO 12 STAINLESS
17	1	291197	CIRCUIT BREAKER,30AMP,INLINEMT
18	2	520067	HOSE CLAMP NO 28 STAINLESS
19	2	520099	HOSE CLAMP NO 40 STAINLESS
20	2	900271	1/2UNC X 3 1/4 HEX BOLT
21	6	914008	1/2UNC HEX STOVER NUT
22	6	920004	1/2 SAE FLAT WASHER
23	1	341968	TIE PLT 250/280 CUMM 92
24	4	900265	1/2UNC X 1 1/2 HEX BOLT
25	1	193012	QUICKEDGE TRIM .135 TO .250
26	1	618573	5/8 HOSE BARB-90-1/2MNP
27	2	520126	CUSH HOSE CLAMP 2IN X 5/8W
28	1	470121	1/4UNC HEX FLANGE LOCK NUT
29	1	470118	1/4UNC X 3/4 FLANGE HEX BOLT
30	1	291556	CIRCUIT BREAKER,50AMP,INLINEMT
31	1	316339	BREAKER MTG PLT, 2100 98
32	1	316340	BREAKER COVER, 2100 98
33	2	473783	12MM-1.75 X 25MM HEX BOLT
34	2	470216	10-32 X 3/4 FLANGE HEX BOLT
35	4	903812	6-32 X 1/2 SLT RD HD MACH SCR
36	8	910022	6-32 HEX NUT
37	4	910027	10-32 HEX NUT
38	4	470175	10-32 HEX FLANGE LOCK NUT

SUNDSTRAND PUMP ASSEMBLY

DET. QTY PART NO. DESCRIPTION

1	1	610300	3/4MJIC-3/4MNPT ADPTR
2	1	316160	PUMP CONT LEVER EXT 280 CUMM
3	8	470188	7/16-14 X 1 1/2 SKTHD CAP SCR
4	8	470189	7/16 HC LOCK WASH FOR 618598
5	1	606902	SUND 100CC PUMP,B-MT W/FILT
6	1	618118	3/4 HOSE BARB-90-1 1/16MOR
7	2	618541	1 5/16FJIC-1 1/16MJIC ADPTR
8	1	618626	1 1/4 HOSE BARB-45-1 5/8MOR
9	2	618598	1" 4-BOLT FLG X 1 5/16 FOR
10	2	618599	1 5/16MOR BRANCH TEE-1 5/16MJ
11	2	870219	BUNA ORING 1 5/16 X 1 9/16
12	2	900003	1/4UNC X 1" HEX BOLT
13	2	914000	1/4UNC HEX STOVER NUT
14	4	920004	1/2 SAE FLAT WASHER
15	1	473921	BALL JOINT NO 10-32 THD
16	2	910027	10-32 HEX NUT
17	1	903893	10-32 X 1" SLT RD HD MACH SCR
18	1	914027	10-32 HEX STOVER NUT
19	2	920510	#10 LOCK WASHER
20	1	606870	O-RING FOR 606865 SUND B-MT
21	1	505101	BLK PIPE TEE 1.00NPT
22	1	505200	BLK PIPE ST EL 90DEG 1.00NPT
23	2	505105	1MNPT HEX PIPE NIPPLE STL
24	1	505213	RED BUSH 1 X 3/4 BLK MAL
25	3	618531	9/16FJIC CAP NUT
26	1	505098	SIDE OUTLET EL 90DEG 1.00NPT
27	1	601383	HOSE, 3/4 X 8 1FBR-1SPI
28	1	606932	SUND GEAR PUMP,1.60CI,SPLINED
29	1	606929	SUND GEAR PUMP .66CI, SPLINED
30	1	611128	7/8MJIC-90-7/8MOR LBO
31	1	618075	3/4 HOSE BARB-1 1/16MOR
32	1	618535	7/8MJIC-90-1 1/16MOR LBO
33	1	618090	1 5/16MOR-1FNPT ADPTR
34	1	714560	1NPT X 1 HOSE BARB
35	1	618328	7/8FJIC CAP NUT
36	1	716000	3/4 HOSE BARB-90-1MNPT
37	4	900265	1/2UNC X 1 1/2 HEX BOLT
38	1	618333	7/8FJIC SW RUN TEE-7/8MJIC
39	2	618327	3/4MJIC-7/8MOR ADPTR
40	1	520055	HOSE CLAMP NO 12 STAINLESS
41	1	618119	9/16MJIC-90-9/16MOR LBO
42	1	520138	1.00 T-BOLT HOSE CLAMP
43	2	920002	3/8 SAE FLAT WASHER
44	2	900130	3/8UNC X 1 1/4 HEX BOLT
45	2	618629	9/16MOR BRANCH TEE-9/16MJIC
46	1	520132	1.62/1.87 T-BOLT HOSE CLAMP
47	1	606924	O-RING FOR SUND A-MT
48	1	618609	3/4MJIC-90-3/4FJIC SWIV LBO
49	2	520137	.75 T-BOLT HOSE CLAMP
50	1	606941	TANDEM PUMP, 606929 & 606932
51	1	618191	1 1/16MJIC-90-1 1/16FJ SWIV LBO

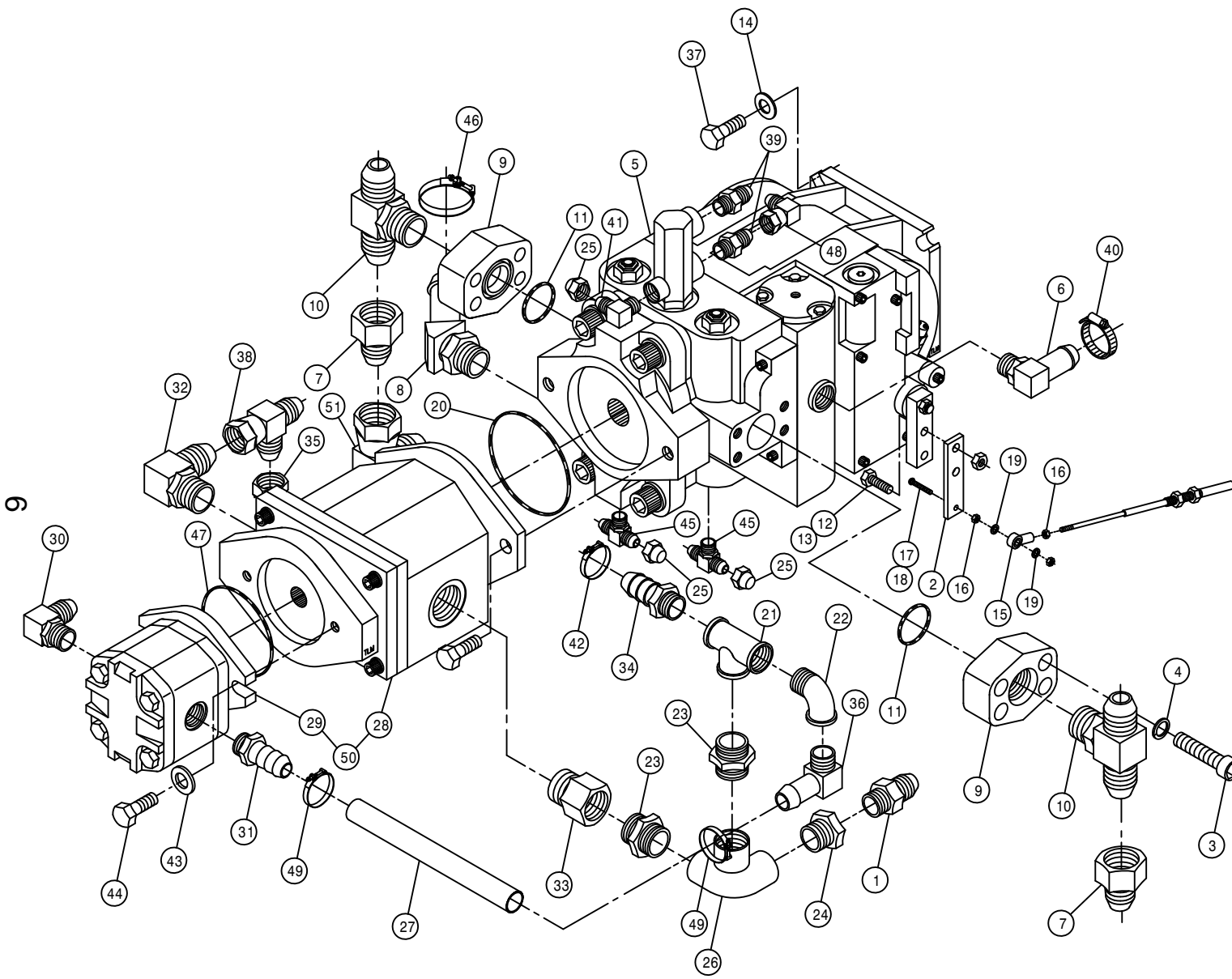

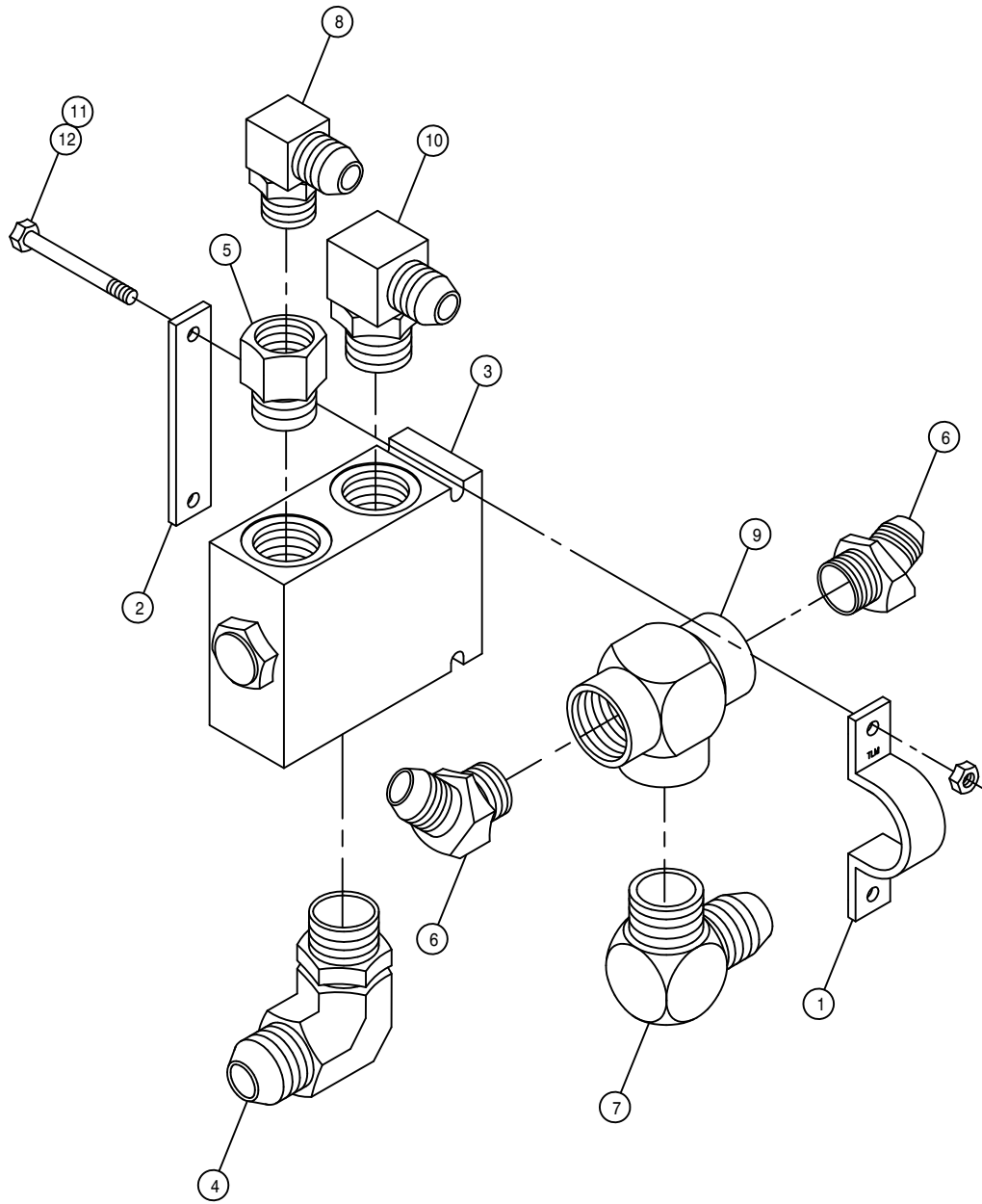

POSITRACTION VALVE ASSEMBLY

DET. QTY PART NO. DESCRIPTION

1	1	314842	TEE CLAMP, TRAC VLV 200	89
2	1	314843	TEE KEEPER, TRAC VLV 200	89
3	1	610609	TRACTION VLV,66S,40GPM	
4	1	618178	1 5/16MJC-90-1 5/16MOR LBO	
5	1	618312	1 5/16MOR-1 1/16FOR ADPTR	
6	2	618339	1 1/16MJC-45-1MNPT LBO	
7	1	618437	1 5/16MJC-90-1MNPT LBO	
8	1	618248	1 1/16MJC-90-1 1/16MOR LBO	
9	1	618575	1FNPT PIPE TEE STL	
10	1	618302	1 1/16MJC-90-1 5/16MOR LBO	
11	2	914000	1/4UNC HEX STOVER NUT	
12	2	900011	1/4UNC X 3 1/4 HEX BOLT	

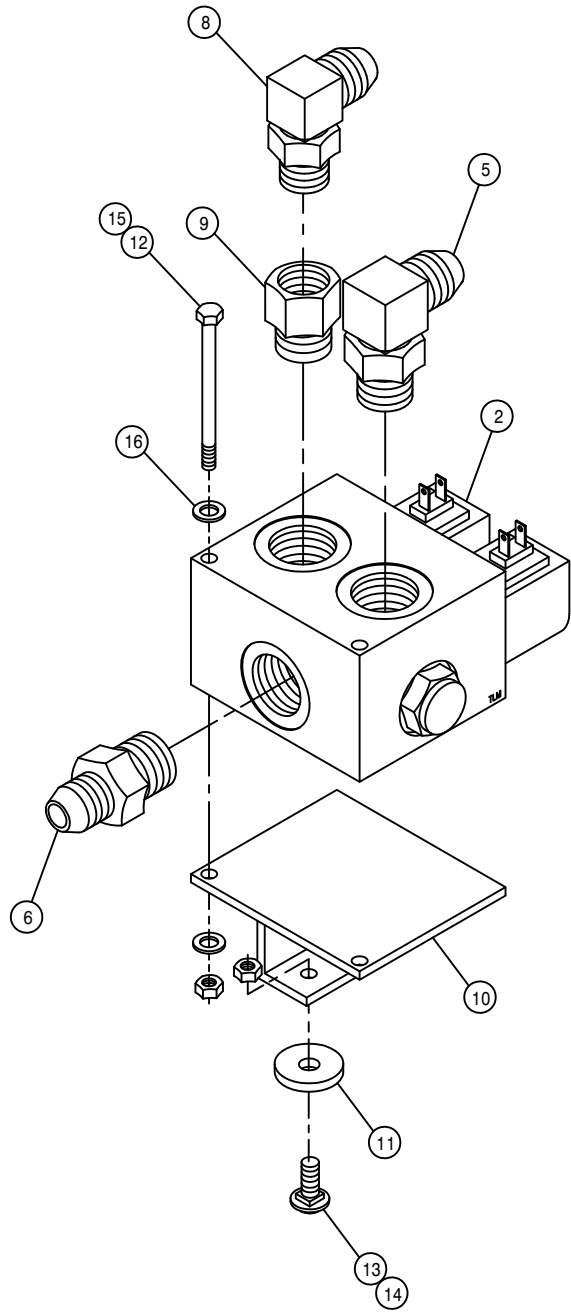

POSITRACTION VALVE ASSEMBLY

DET.	QTY	PART NO.	DESCRIPTION
	1	2	505213 RED BUSH 1 X 3/4 BLK MAL
	2	1	610469 POSITRACTION VLV MOD CONT 40G
	3	1	618575 1FNPT PIPE TEE STL
	4	2	618156 7/8MJC-90-3/4MNPT LBO
	5	1	618589 7/8MJC-90-1 5/16MOR LBO
	6	1	618308 1 1/16MJC-1 5/16MOR ADPTR
	7	1	618434 1 1/16MJC-1MNPT ADPTR
	8	1	618535 7/8MJC-90-1 1/16MOR LBO
	9	1	618312 1 5/16MOR-1 1/16FOR ADPTR
	10	1	342283 TRAC VLV MT WLD, 254 X-11 94
	11	2	748501 RUBBER WASH .38 X .406 X 1.50
	12	2	900076 5/16UNC X 4" HEX BOLT
	13	2	901130 3/8UNC X 1 1/4 CARR BOLT
	14	2	914004 3/8UNC HEX STOVER NUT
	15	2	914002 5/16UNC HEX STOVER NUT
	16	4	920001 5/16 SAE FLAT WASHER

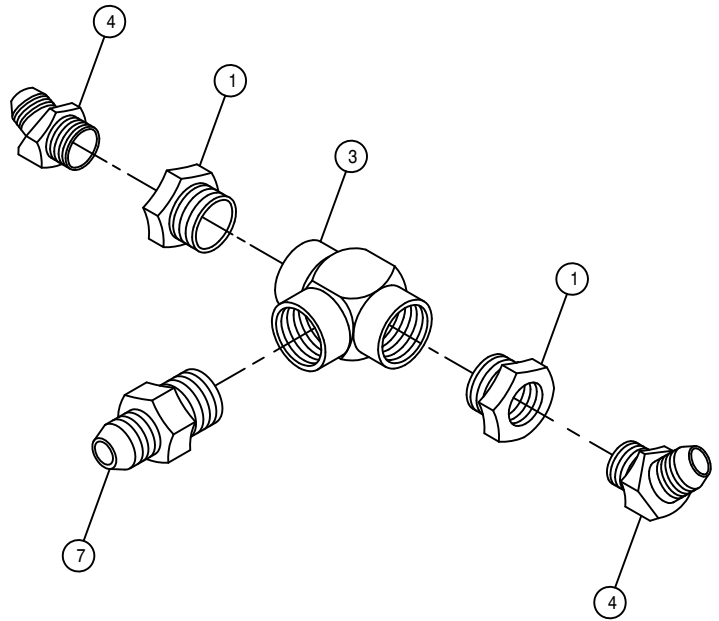

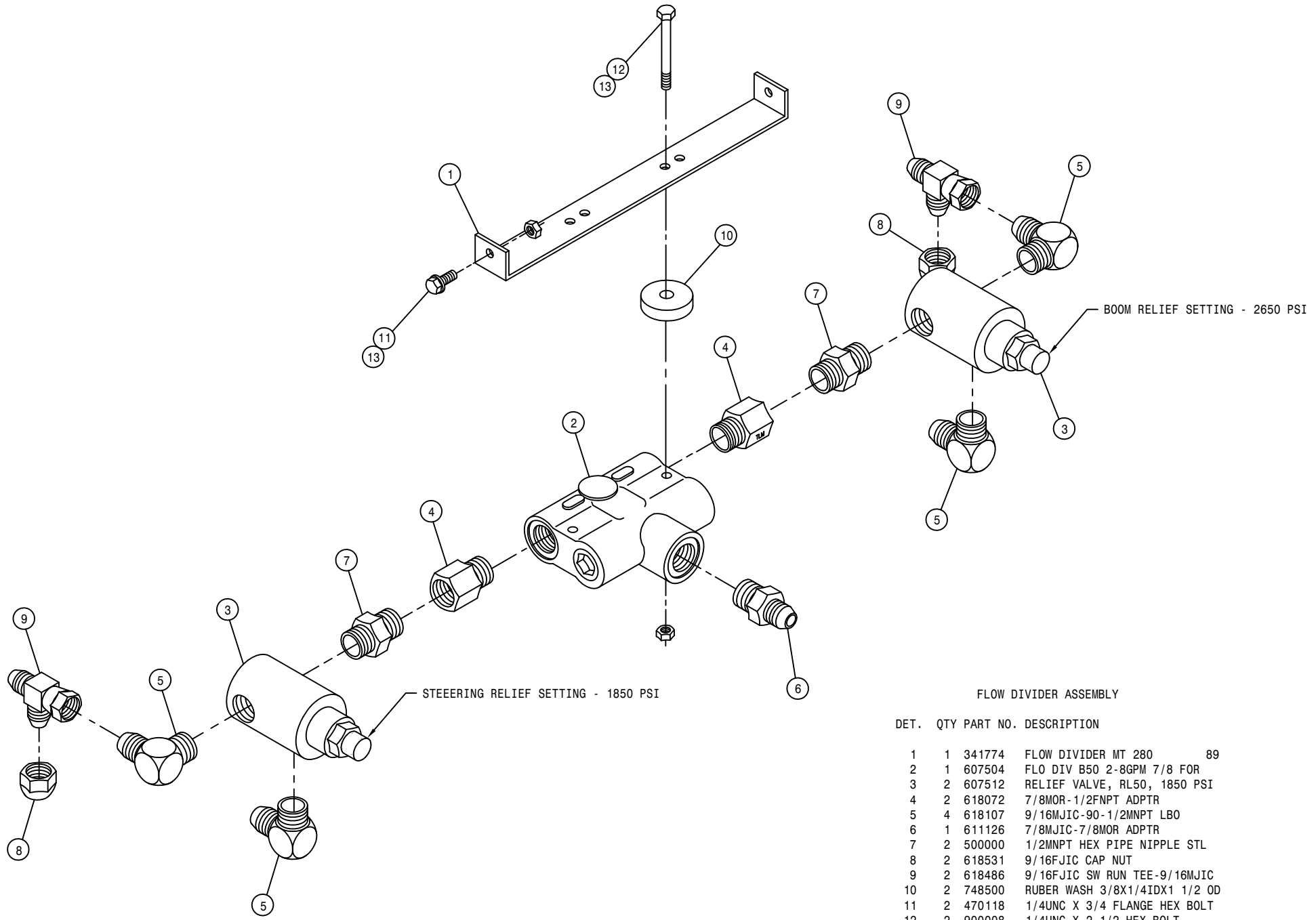

FLOW DIVIDER ASSEMBLY

DET.	QTY	PART NO.	DESCRIPTION
1	1	341774	FLOW DIVIDER MT 280 89
2	1	607504	FLO DIV B50 2-8GPM 7/8 FOR
3	2	607512	RELIEF VALVE, RL50, 1850 PSI
4	2	618072	7/8MOR-1/2FNPT ADPTR
5	4	618107	9/16MJIC-90-1/2MNPT LBO
6	1	611126	7/8MJIC-7/8MOR ADPTR
7	2	500000	1/2MNPT HEX PIPE NIPPLE STL
8	2	618531	9/16FJIC CAP NUT
9	2	618486	9/16FJIC SW RUN TEE-9/16MJIC
10	2	748500	RUBER WASH 3/8X1/4IDX1 1/2 OD
11	2	470118	1/4UNC X 3/4 FLANGE HEX BOLT
12	2	900008	1/4UNC X 2 1/2 HEX BOLT
13	4	914000	1/4UNC HEX STOVER NUT

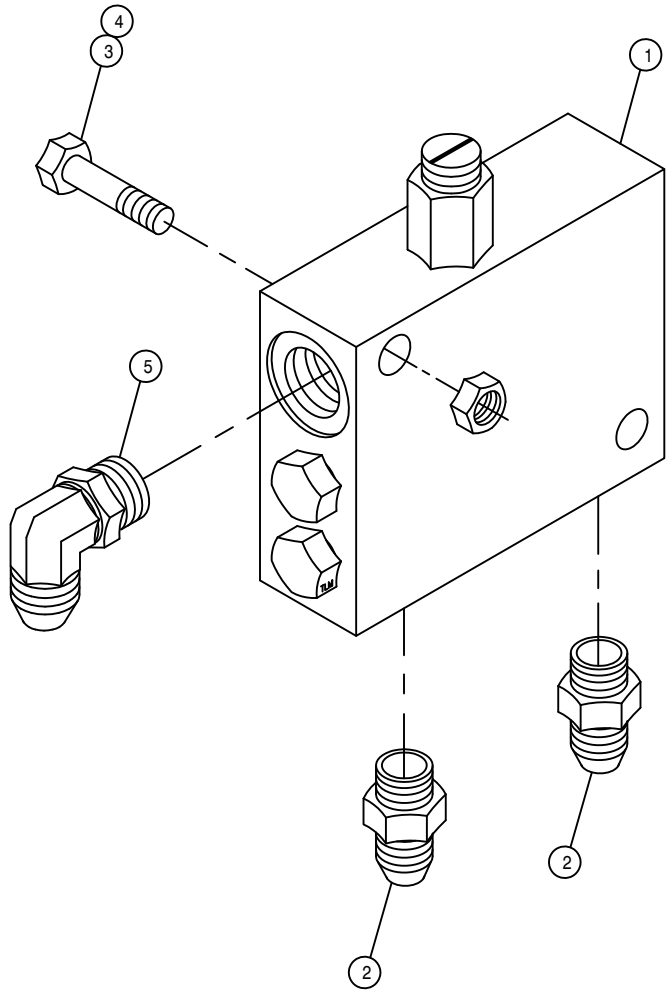

LOOP FLUSHING VALVE ASSEMBLY

DET. QTY PART NO. DESCRIPTION

1	1	610580	REMOTE FLUSHING VALVE, SUND
2	2	618126	9/16MJIC-9/16MOR ADPTR
3	2	900133	3/8UNC X 2 HEX BOLT
4	2	914004	3/8UNC HEX STOVER NUT
5	1	618119	9/16MJIC-90-9/16MOR LBO

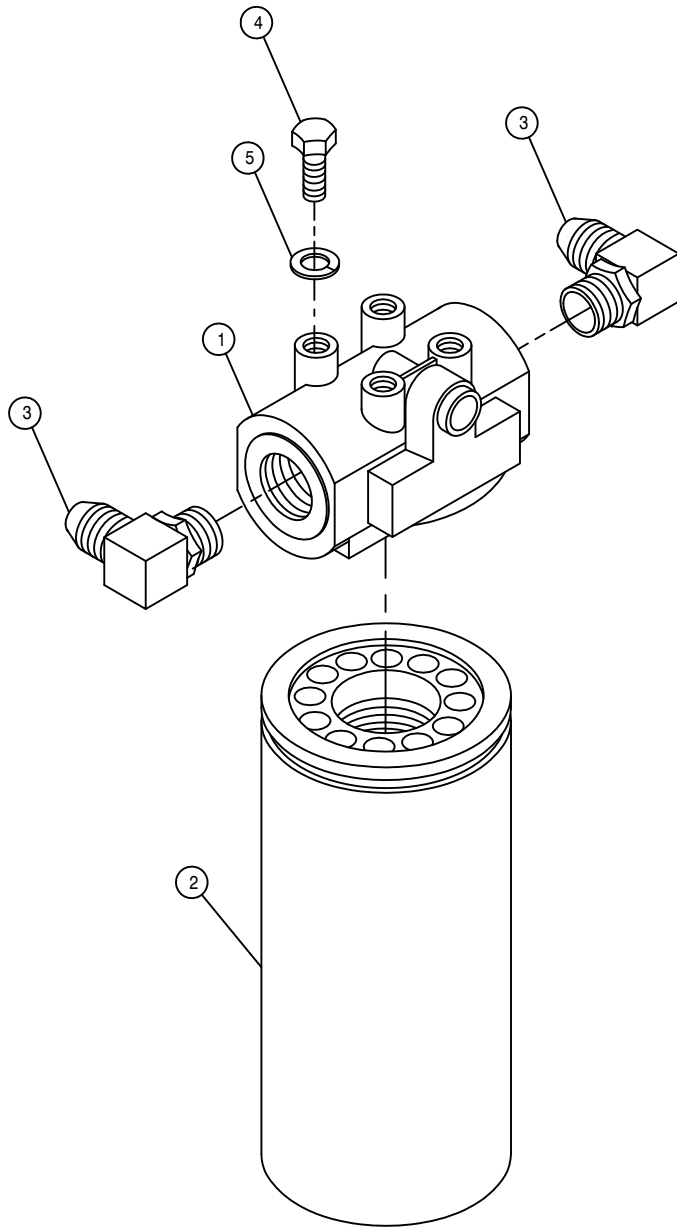

HI-PRESS FILTER ASSEMBLY

DET. QTY PART NO. DESCRIPTION

1	1	605608	HYD FILTER HEAD, DONALDSON
2	1	605609	HYD FILTER ELEMENT, DONALDSON
3	2	618474	3/4MJIC-90-1 1/16MOR LBO
4	4	900128	3/8UNC X 3/4 HEX BOLT
5	4	920502	3/8 LOCK WASHER

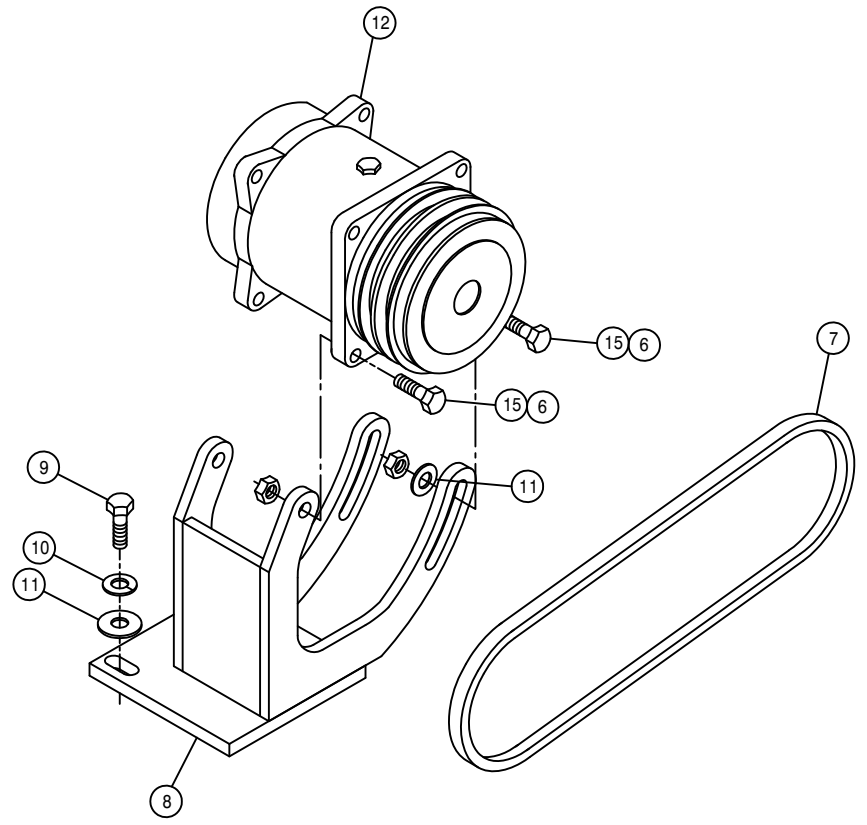
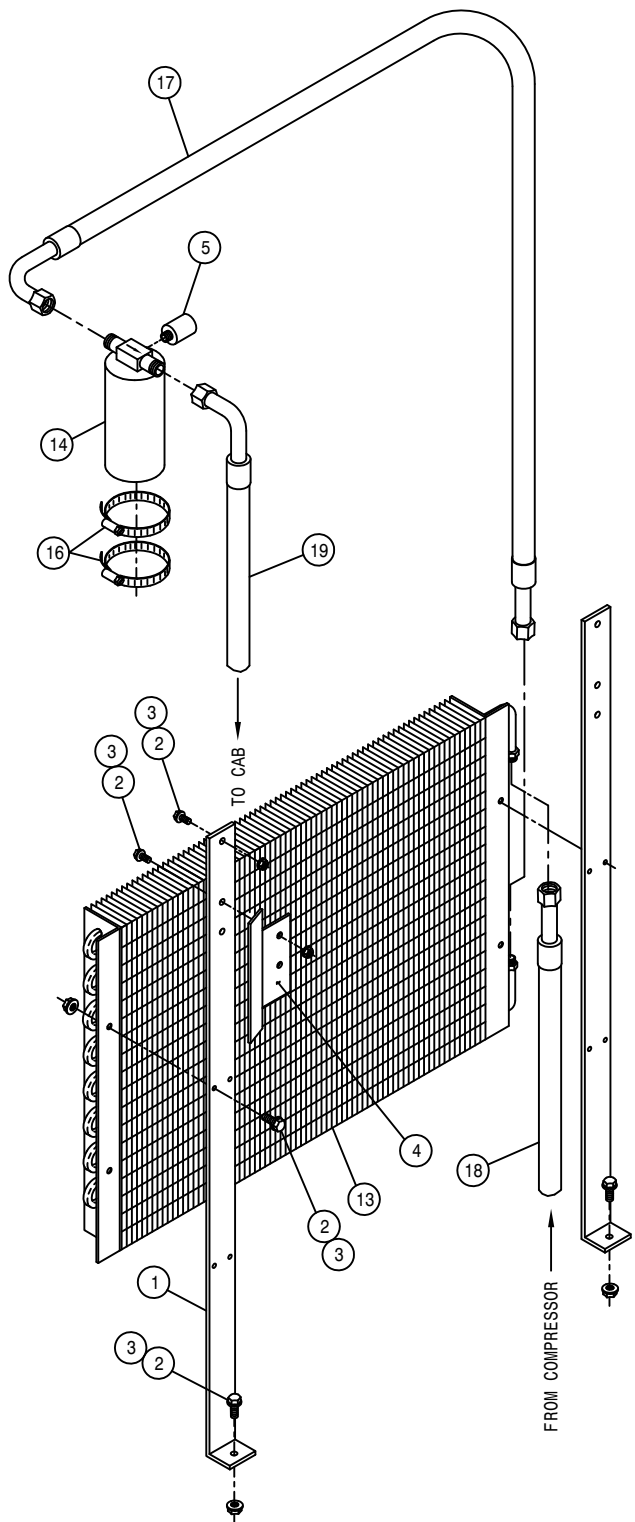

A/C COMPRESSOR PUMP ASSEMBLY

DET.	QTY	PART NO.	DESCRIPTION	
	2	315036	CONDENSER MTG BRKT	99
	10	470118	1/4UNC X 3/4 FLANGE HEX BOLT	
	3	470121	1/4UNC HEX FLANGE LOCK NUT	
	4	315038	A/C DRIER MT, 204-254-284	99
	5	657422	A/C BINARY SWITCH	MCC
	4	914004	3/8UNC HEX STOVER NUT	
	7	147050	9455XL BELT, GATES	
	8	316314	A/C COMPRESSOR MT WLD, 284	98
	9	473792	10MM-1.50 X 30MM HEX BOLT	
	10	473798	10MM LOCK WASHER	
	11	483043	3/8 REGULAR FLAT WASHER	
	12	657403	A/C COMPRESSOR, SELTEC TM15/12	
	13	657423	A/C CONDENSER COIL	MCC
	14	657421	A/C RECEIVER/DRIER	MCC
	15	900131	3/8UNC X 1 1/2 HEX BOLT	
	16	520052	HOSE CLAMP NO 52 STAINLESS	
	17	657429	A/C HOSE ASSY, 5/16 X 44	MCC
	18	657430	A/C HOSE ASSY, 13/32 X 80	MCC
	19	657431	A/C HOSE ASSY, 5/16 X 173	MCC

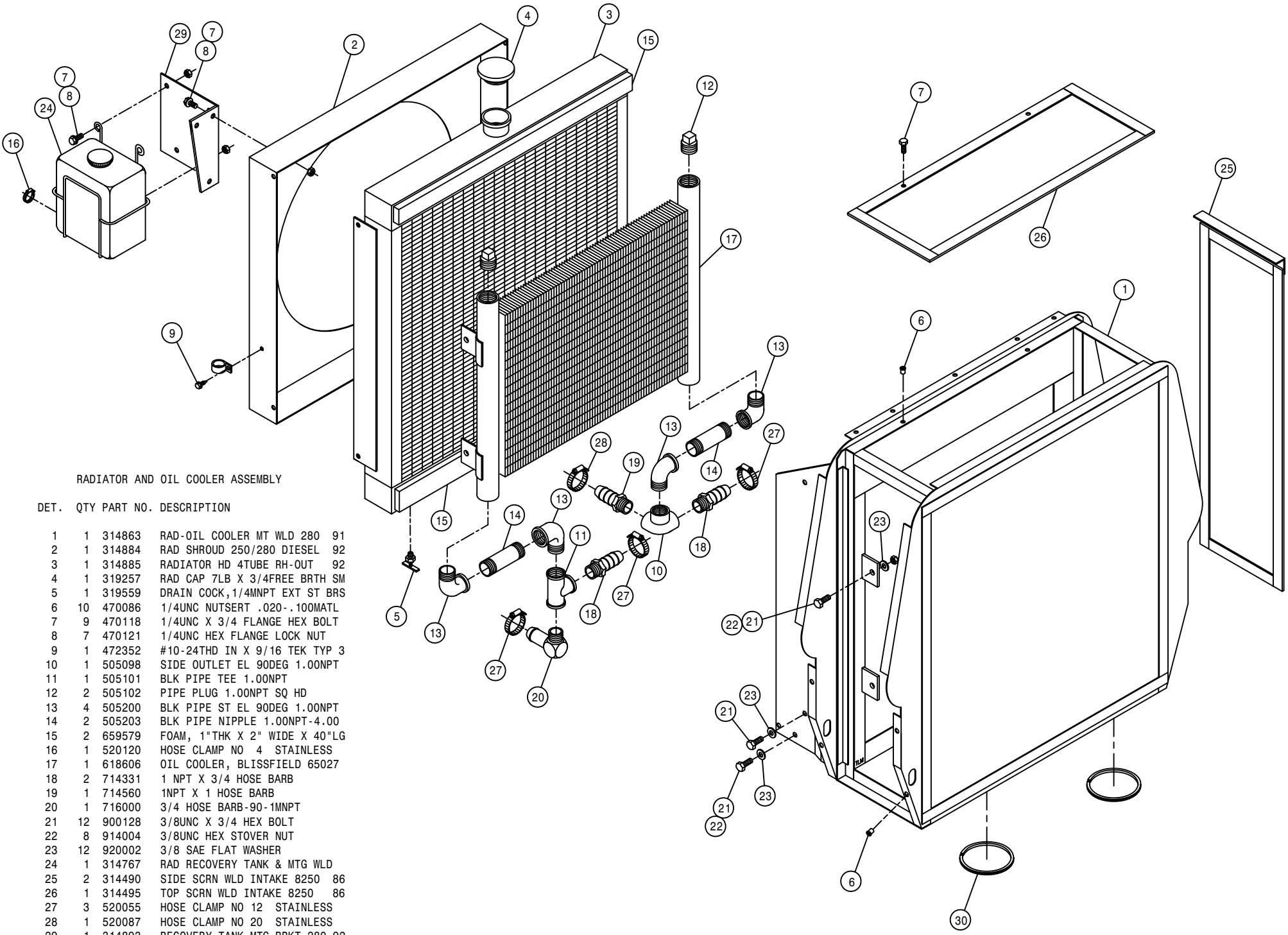

RADIATOR AND OIL COOLER ASSEMBLY

DET. QTY PART NO. DESCRIPTION

1	1	314863	RAD-OIL COOLER MT WLD 280 91
2	1	314884	RAD SHROUD 250/280 DIESEL 92
3	1	314885	RADIATOR HD 4TUBE RH-OUT 92
4	1	319257	RAD CAP 7LB X 3/4FREE BRTH SM
5	1	319559	DRAIN COCK, 1/4MNPT EXT ST BR
6	10	470086	1/4UNC NUTSERT .020-.100MATL
7	9	470118	1/4UNC X 3/4 FLANGE HEX BOLT
8	7	470121	1/4UNC HEX FLANGE LOCK NUT
9	1	472352	#10-24THD IN X 9/16 TEK TYP 3
10	1	505098	SIDE OUTLET EL 90DEG 1.00NPT
11	1	505101	BLK PIPE TEE 1.00NPT
12	2	505102	PIPE PLUG 1.00NPT SQ HD
13	4	505200	BLK PIPE ST EL 90DEG 1.00NPT
14	2	505203	BLK PIPE NIPPLE 1.00NPT-4.00
15	2	659579	FOAM, 1"THK X 2" WIDE X 40"LG
16	1	520120	HOSE CLAMP NO 4 STAINLESS
17	1	618606	OIL COOLER, BLISSFIELD 65027
18	2	714331	1 NPT X 3/4 HOSE BARB
19	1	714560	1NPT X 1 HOSE BARB
20	1	716000	3/4 HOSE BARB-90-1MNPT
21	12	900128	3/8UNC X 3/4 HEX BOLT
22	8	914004	3/8UNC HEX STOVER NUT
23	12	920002	3/8 SAE FLAT WASHER
24	1	314767	RAD RECOVERY TANK & MTG WLD
25	2	314490	SIDE SCR N WLD INTAKE 8250 86
26	1	314495	TOP SCR N WLD INTAKE 8250 86
27	3	520055	HOSE CLAMP NO 12 STAINLESS
28	1	520087	HOSE CLAMP NO 20 STAINLESS
29	1	314893	RECOVERY TANK MTG BRKT 280 92
30	2	193016	QUICKEDGE TRIM .060 TO .170 X 10"

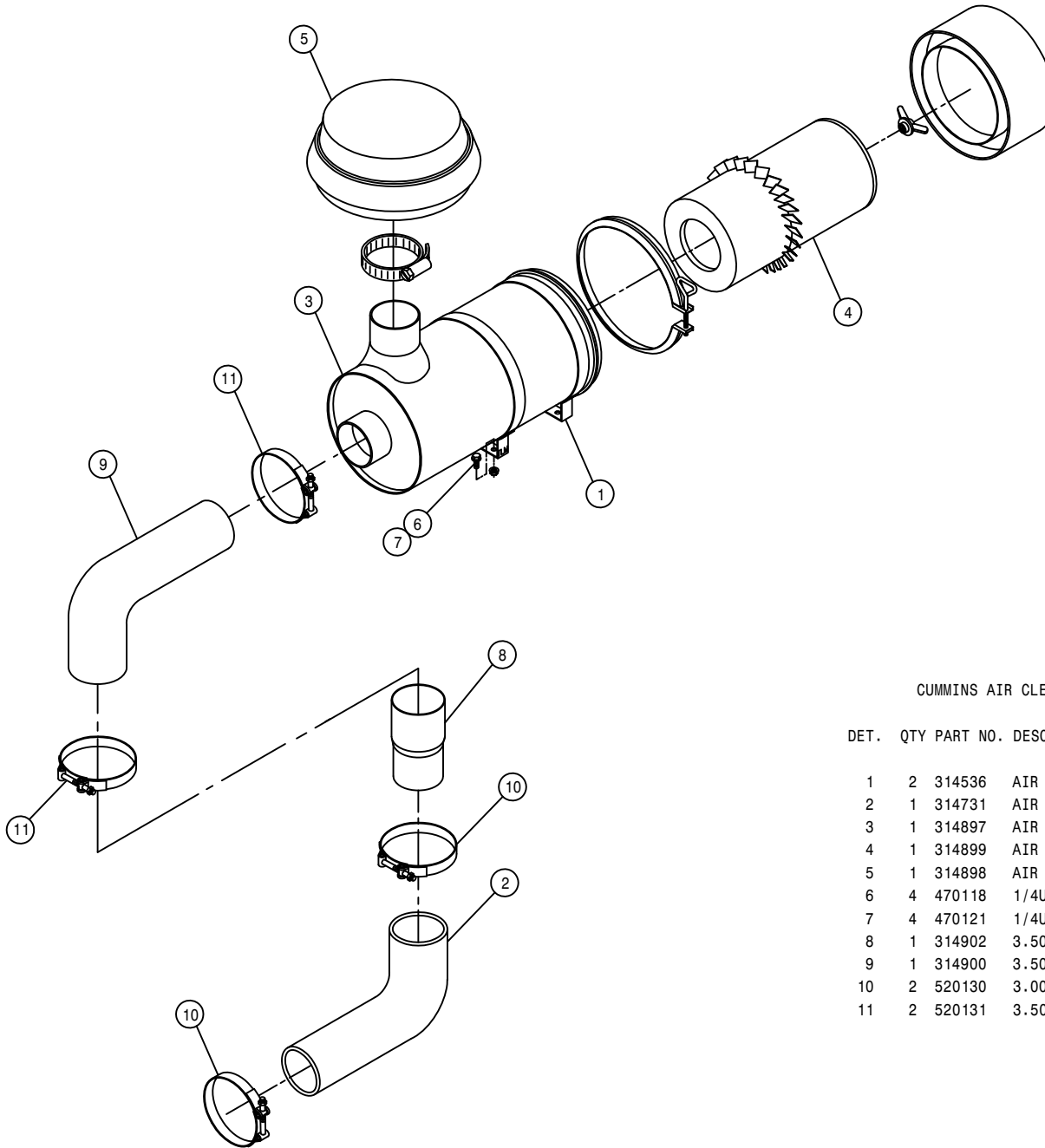

CUMMINS AIR CLEANER ASSEMBLY

DET. QTY PART NO. DESCRIPTION

1	2	314536	AIR CLEANER BAND 8IN DONALDSO
2	1	314731	AIR CLEANER HOSE 8240
3	1	314897	AIR CLEANER, 280 CFM
4	1	314899	AIR CLEANER ELEMENT FOR314897
5	1	314898	AIR CLEANER HOOD FOR 314897
6	4	470118	1/4UNC X 3/4 FLANGED HEX BOLT
7	4	470121	1/4UNC HEX FLANGED LOCK NUT
8	1	314902	3.50 - 3.00 X 6.00LG PIPE
9	1	314900	3.50 90 DEG AIR INTAKE HOSE
10	2	520130	3.00 T-BOLT HOSE CLAMP
11	2	520131	3.50 T-BOLT HOSE CLAMP

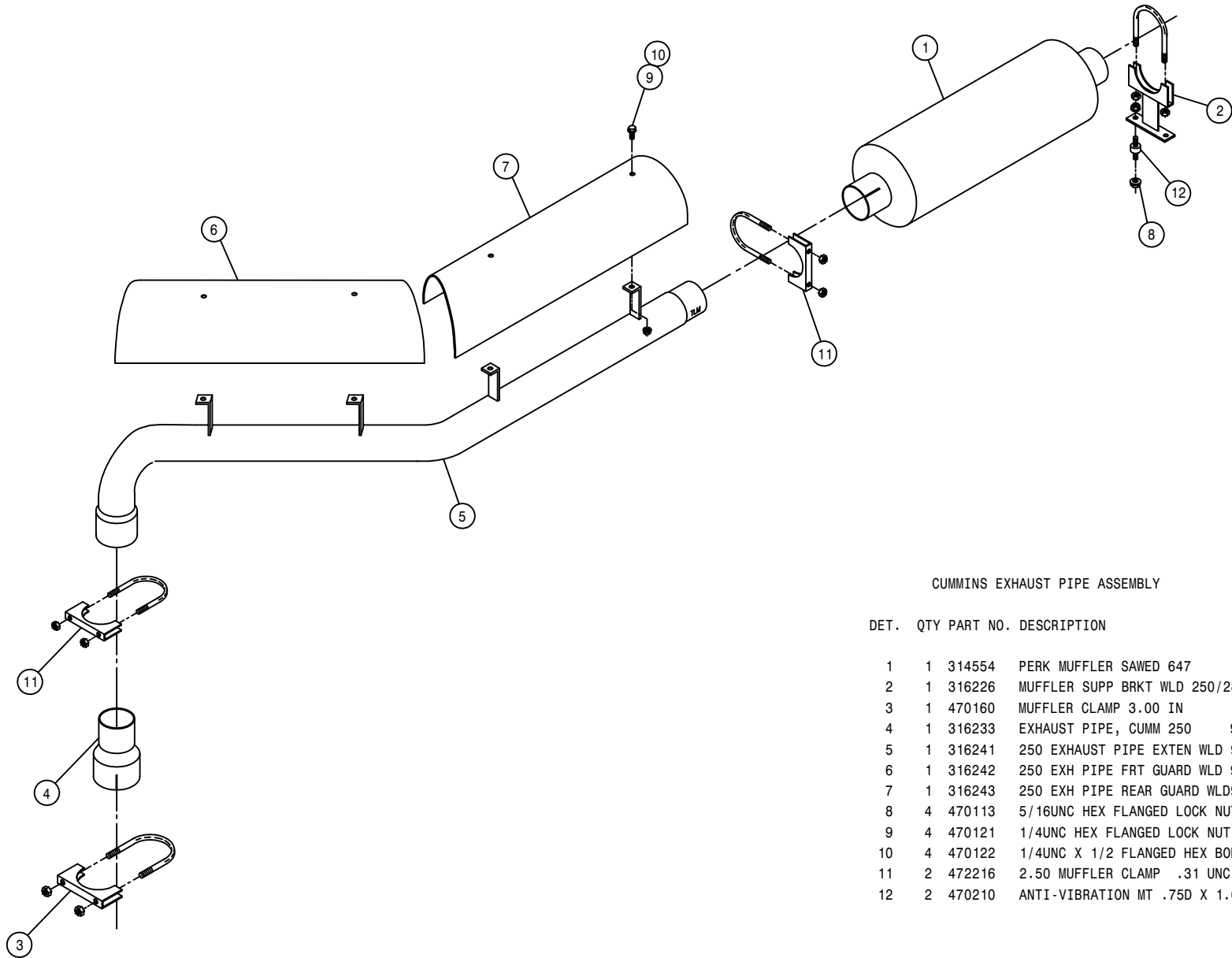

CUMMINS EXHAUST PIPE ASSEMBLY

DET. QTY PART NO. DESCRIPTION

DET.	QTY	PART NO.	DESCRIPTION
1	1	314554	PERK MUFFLER SAWED 647
2	1	316226	MUFFLER SUPP BRKT WLD 250/280
3	1	470160	MUFFLER CLAMP 3.00 IN
4	1	316233	EXHAUST PIPE, CUMM 250 93
5	1	316241	250 EXHAUST PIPE EXTEN WLD 93
6	1	316242	250 EXH PIPE FRT GUARD WLD 93
7	1	316243	250 EXH PIPE REAR GUARD WLD93
8	4	470113	5/16UNC HEX FLANGED LOCK NUT
9	4	470121	1/4UNC HEX FLANGED LOCK NUT
10	4	470122	1/4UNC X 1/2 FLANGED HEX BOLT
11	2	472216	2.50 MUFFLER CLAMP .31 UNC
12	2	470210	ANTI-VIBRATION MT .75D X 1.00

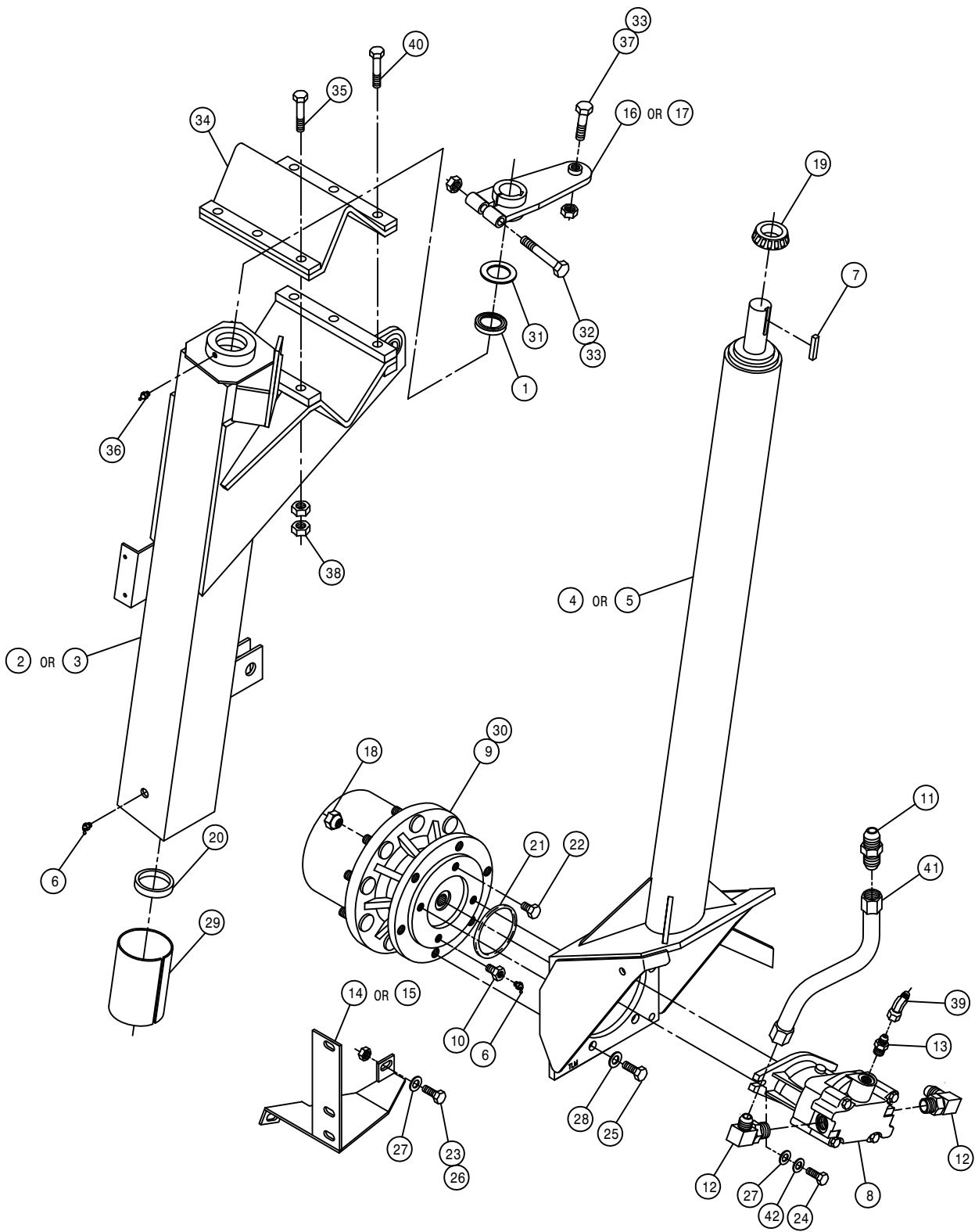

FRONT LEG ASSEMBLY

DET.	QTY	PART NO.	DESCRIPTION
1	1	129010	SEAL C/R 16069
2	1	358817	RH FRT OUTR LEG WLD,254X11 95
3	1	358818	LH FRT OUTR LEG WLD,254X11 95
4	1	358679	RH FRT INNER LEG WLD250X11 92
5	1	358680	LH FRT INNER LEG WLD250X11 92
6	2	471023	GREASE ZERK 1/4-28 X 45
7	1	483036	KEY, 3/8 SQ X 2" LG
8	1	610571	SUND M35-3002 WHL MTR
9	1	610516	TORQ HUB, 24:1 B-MT W1BFNZ
10	1	610556	1/2UNC X 1/2 ZERK BOLT T-HUB
11	1	618456	7/8MJIC UNION
12	2	618535	7/8MJIC-90-1 1/16MOR LBO
13	1	618310	9/16MJIC-7/8MOR ADPTR
14	1	662157	RH FRT MTG WLD FOR CROP GUIDE
15	1	662156	LH FRT MTG WLD FOR CROP GUIDE
16	1	749280	RH STRG ARM WLD 250 91
17	1	749281	LH STRG ARM WLD 250 91
18	9	824052	1/2UNF 60 DEG WHL NUT
19	1	825003	INNER CONE FOR 825001 &825002
20	1	825004	INNER CUP FOR 825001 & 825002
21	1	870045	O-RING 4 1/8 OD X 4 ID
22	1	900260	1/2UNC X 1/2 H BOLT GR2 UNPLT
23	3	900265	1/2UNC X 1 1/2 HEX BOLT
24	2	900266	1/2UNC X 1 3/4 HEX BOLT
25	6	900333	5/8UNC X 1 1/2 HEX BOLT
26	3	914008	1/2UNC HEX STOVER NUT
27	5	920004	1/2 SAE FLAT WASHER
28	6	920505	5/8 LOCK WASHER
29	1	358298	JOURNAL BRG-LINER TYPE
30	1	610552	SEAL BOOT FOR W1BFNZ, W2B2FZ
31	1	358448	FRT LEG WSHR 8540
32	1	900343	5/8UNC X 4 1/2 HEX BOLT
33	2	914010	5/8UNC HEX STOVER NUT
34	1	358780	LEG MT V-PLT WLD, 254 95
35	3	900836	5/8UNF X 3 1/4 HEX BOLT GR8
36	1	471021	GREASE ZERK 1/8 NPT STRAIGHT
37	1	749269	STRG ARM BOLT 280 89
38	12	914811	5/8UNF HEX NUT GR8
39	1	618634	9/16MJIC-45-9/16FJIC SWIV LBO
40	3	900837	5/8UNF X 3 1/2 HEX BOLT GR8
41	1	615681	FRT WHL MTR HYD TUBE ASSY,X11
42	2	920504	1/2 LOCK WASHER

REAR LEG ASSEMBLY

DET. QTY PART NO. DESCRIPTION

1	1	342091	LEG BRACE WLD, 254	95
2	3	900836	5/8UNF X 3 1/4 HEX BOLT GR8	
3	1	358780	LEG MT V-PLT WLD, 254	95
4	1	291206	SENSOR, SPEEDO/TACH W/NUT	
5	1	358596	RH REAR WHL MTR SHLD WLD 280	
6	1	358820	LH REAR LEG WLD, 254 X-11 95	
7	1	358819	RH REAR LEG WLD, 254 X-11 95	
8	1	358597	LH REAR WHL MTR SHLD WLD 280	
9	1	471023	GREASE ZERK 1/4-28 X 45	
10	2	473061	3/4UNF TRUSEAL HEX NUT	
11	1	610516	TORQ HUB, 24:1 B-MT W1BFNZ	
12	1	610556	1/2UNC X 1/2 ZERK BOLT T-HUB	
13	1	610557	SUND M35-3102 WHL MTR W/SHFT	
14	1	614700	FRT HYD TUBE ASSY 250 X-11 92	
15	1	614701	REAR HYD TUBE ASSY 250 X11 92	
16	1	618172	7/8MOR-9/16FOR ADPTR	
17	2	618248	1 1/16MJIC-90-1 1/16MOR LBO	
18	1	618425	9/16MJIC-45-9/16MOR LBO	
19	1	618529	1 1/16MJ-45-1 1/16FJ SWIV LBO	
20	9	824052	1/2UNF 60 DEG WHL NUT	
21	1	826929	CLIP BRAKE RETAINER	
22	1	826945	HUB MOUNT, BRAKE	
23	1	826959	BRAKE DISC SUB ASSY	
24	1	826963	SENSOR DISC, 647 BRAKE FORMED	
25	1	826975	TAPER LOCK HUB	
26	1	826988	HUB, TAPER LOCK 13 TEETH	
27	1	828083	RH BRAKE MT WLD 250	91
28	1	828084	LH BRAKE MT WLD 250	91
29	2	826918	PARK BRAKE PAD	
30	1	870045	O-RING 4 1/8 OD X 4 ID	
31	1	900002	1/4UNC X 3/4 HEX BOLT	
32	8	900064	5/16UNC X 3/4 HEX BOLT	
33	2	900130	3/8UNC X 1 1/4 HEX BOLT	
34	1	900260	1/2UNC X 1/2 H BOLT GR2 UNPLT	
35	2	900262	1/2UNC X 3/4 HEX BOLT	
36	2	900265	1/2UNC X 1 1/2 HEX BOLT	
37	2	900266	1/2UNC X 1 3/4 HEX BOLT	
38	6	900333	5/8UNC X 1 1/2 HEX BOLT	
39	1	914000	1/4UNC HEX STOVER NUT	
40	2	914004	3/8UNC HEX STOVER NUT	
41	2	914008	1/2UNC HEX STOVER NUT	
42	2	920002	3/8 SAE FLAT WASHER	
43	2	920004	1/2 SAE FLAT WASHER	
44	6	920505	5/8 LOCK WASHER	
45	1	826926	190 IN BRAKE CABLE	
46	1	610552	SEAL BOOT FOR W1BFNZ, W2B2FZ	
47	2	914010	5/8UNC HEX STOVER NUT	
48	2	900336	5/8UNC X 2 1/2 HEX BOLT	
49	12	914811	5/8UNF HEX NUT GR8	
50	3	900837	5/8UNF X 3 1/2 HEX BOLT GR8	
51	2	920504	1/2 LOCK WASHER	

NOTE: 1. ITEMS 4, 10, 24, AND 27 ARE USED ON THE RIGHT HAND LEG ASSEMBLY.

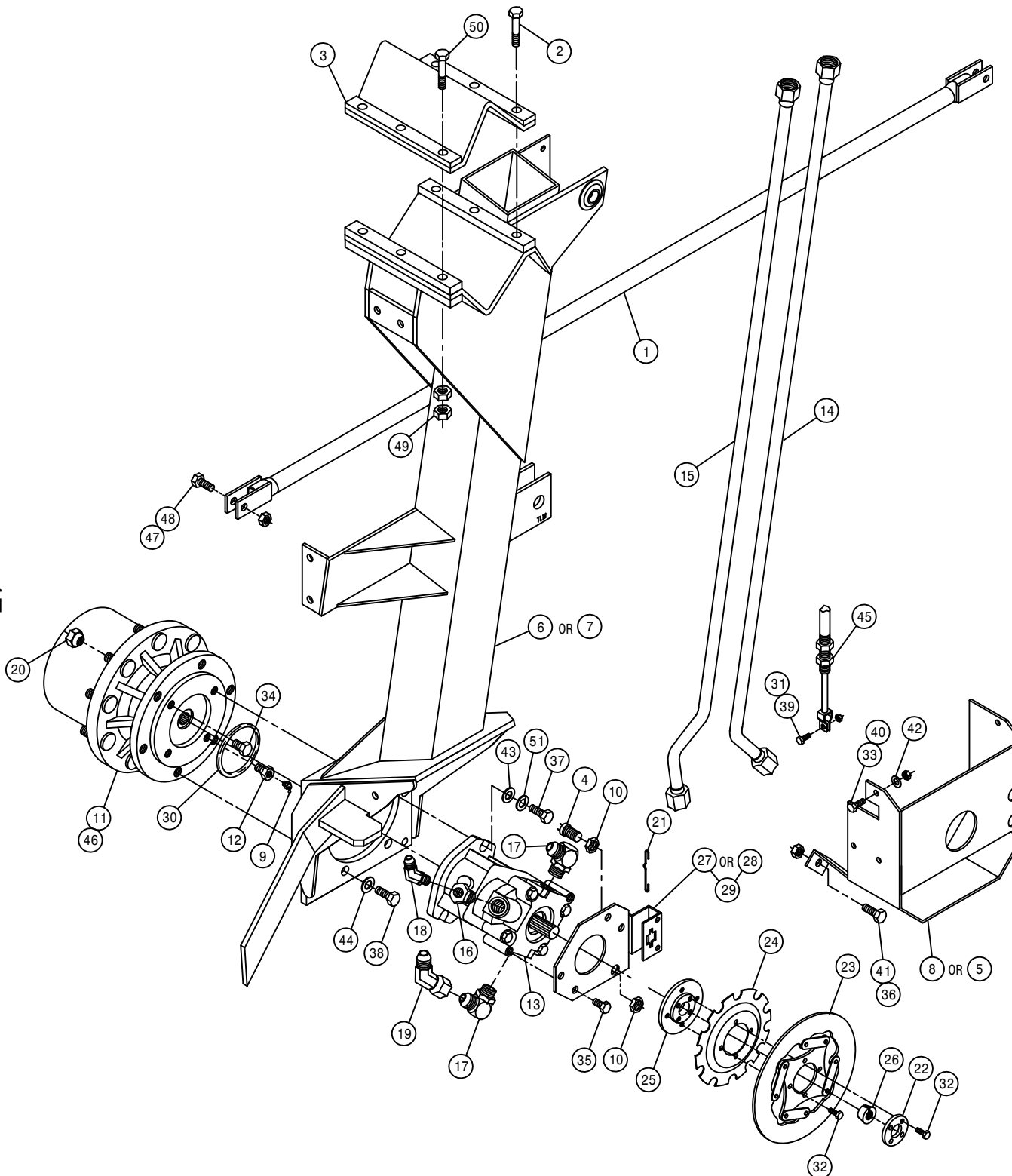

17

189017

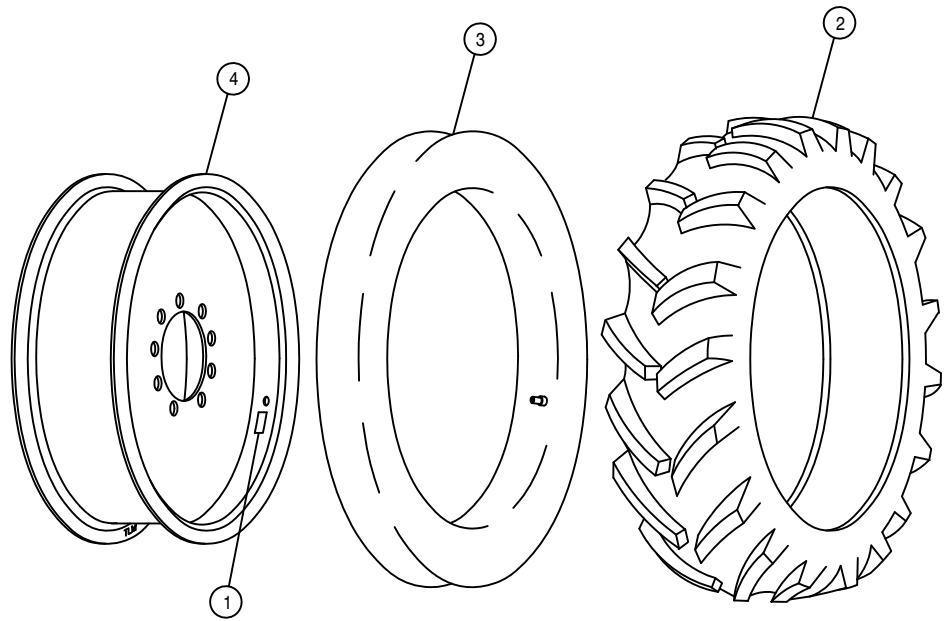

TIRE AND RIM ASSEMBLY

DET.	QTY	PART NO.	DESCRIPTION
1	1	650985	WHL BOLT TORQ DECAL 203854C
2	1	820001	12.4 X 28 4P TIRE, FIRESTONE
3	1	820002	12.4 X 28 RADIAL TUBE
4	1	820017	RIM WLD, W10 X 28, W1B 280

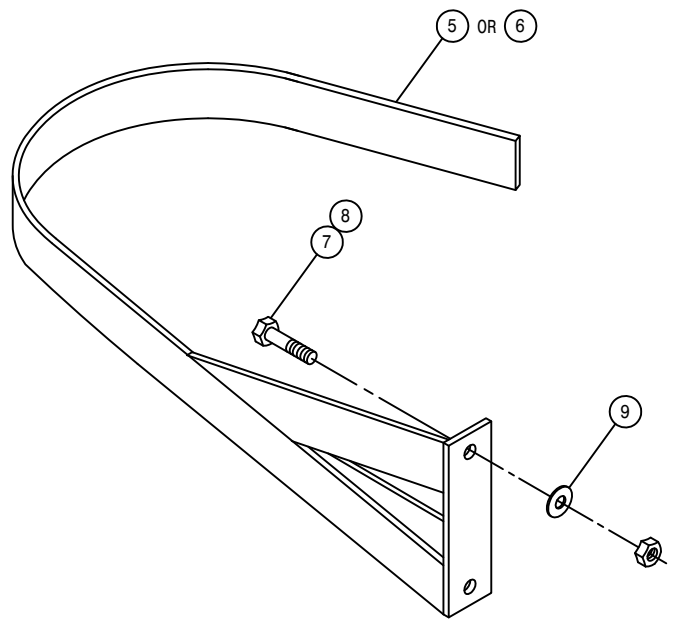
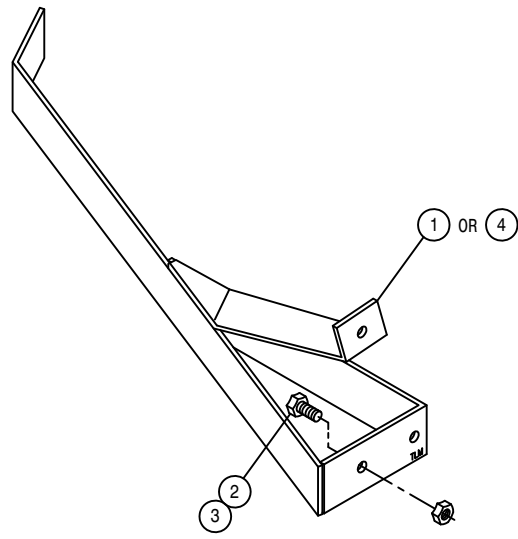

CROP GUIDES

DET.	QTY	PART NO.	DESCRIPTION
1	1	662218	LH REAR STALK GUIDE WLD280 89
2	2	900129	3/8UNC X 1" HEX BOLT
3	2	914004	3/8UNC HEX STOVER NUT
4	1	662217	RH REAR STALK GUIDE WLD280 89
5	1	662150	RH STALK GUIDE WLD 8240
6	1	662151	LH STALK GUIDE WLD 8240
7	2	900264	1/2UNC X 1 1/4 HEX BOLT
8	2	914008	1/2UNC HEX STOVER NUT
9	2	920004	1/2 SAE FLAT WASHER

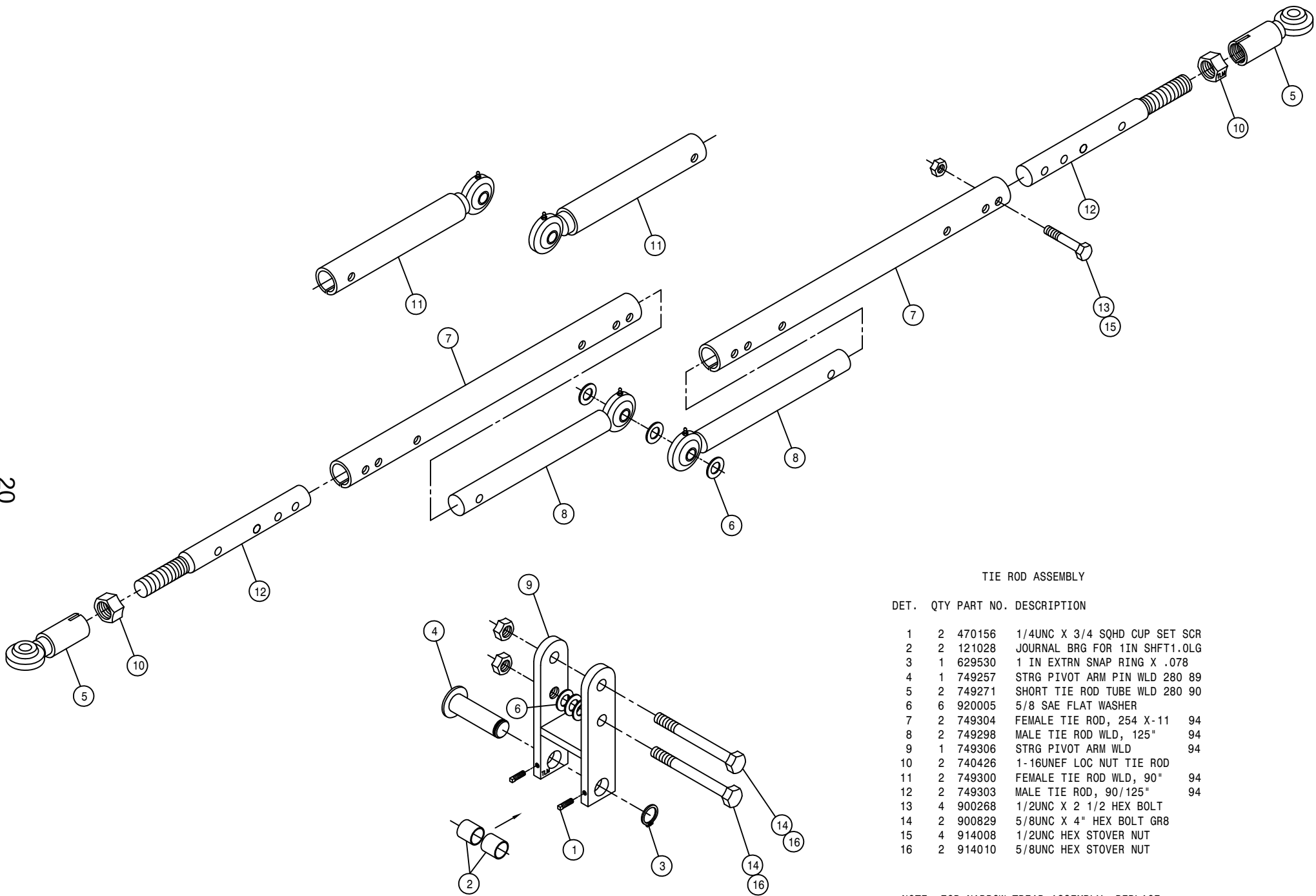

TIE ROD ASSEMBLY

DET.	QTY	PART NO.	DESCRIPTION	
1	2	470156	1/4UNC X 3/4 SQHD CUP SET SCR	
2	2	121028	JOURNAL BRG FOR 1IN SHFT1.0LG	
3	1	629530	1 IN EXTRN SNAP RING X .078	
4	1	749257	STRG PIVOT ARM PIN WLD 280 89	
5	2	749271	SHORT TIE ROD TUBE WLD 280 90	
6	6	920005	5/8 SAE FLAT WASHER	
7	2	749304	FEMALE TIE ROD, 254 X-11	94
8	2	749298	MALE TIE ROD WLD, 125"	94
9	1	749306	STRG PIVOT ARM WLD	94
10	2	740426	1-16UNEF LOC NUT TIE ROD	
11	2	749300	FEMALE TIE ROD WLD, 90"	94
12	2	749303	MALE TIE ROD, 90/125"	94
13	4	900268	1/2UNC X 2 1/2 HEX BOLT	
14	2	900829	5/8UNC X 4" HEX BOLT GR8	
15	4	914008	1/2UNC HEX STOVER NUT	
16	2	914010	5/8UNC HEX STOVER NUT	

NOTE: FOR NARROW TREAD ASSEMBLY, REPLACE
DETAIL 7 AND 8 WITH DETAIL 11.

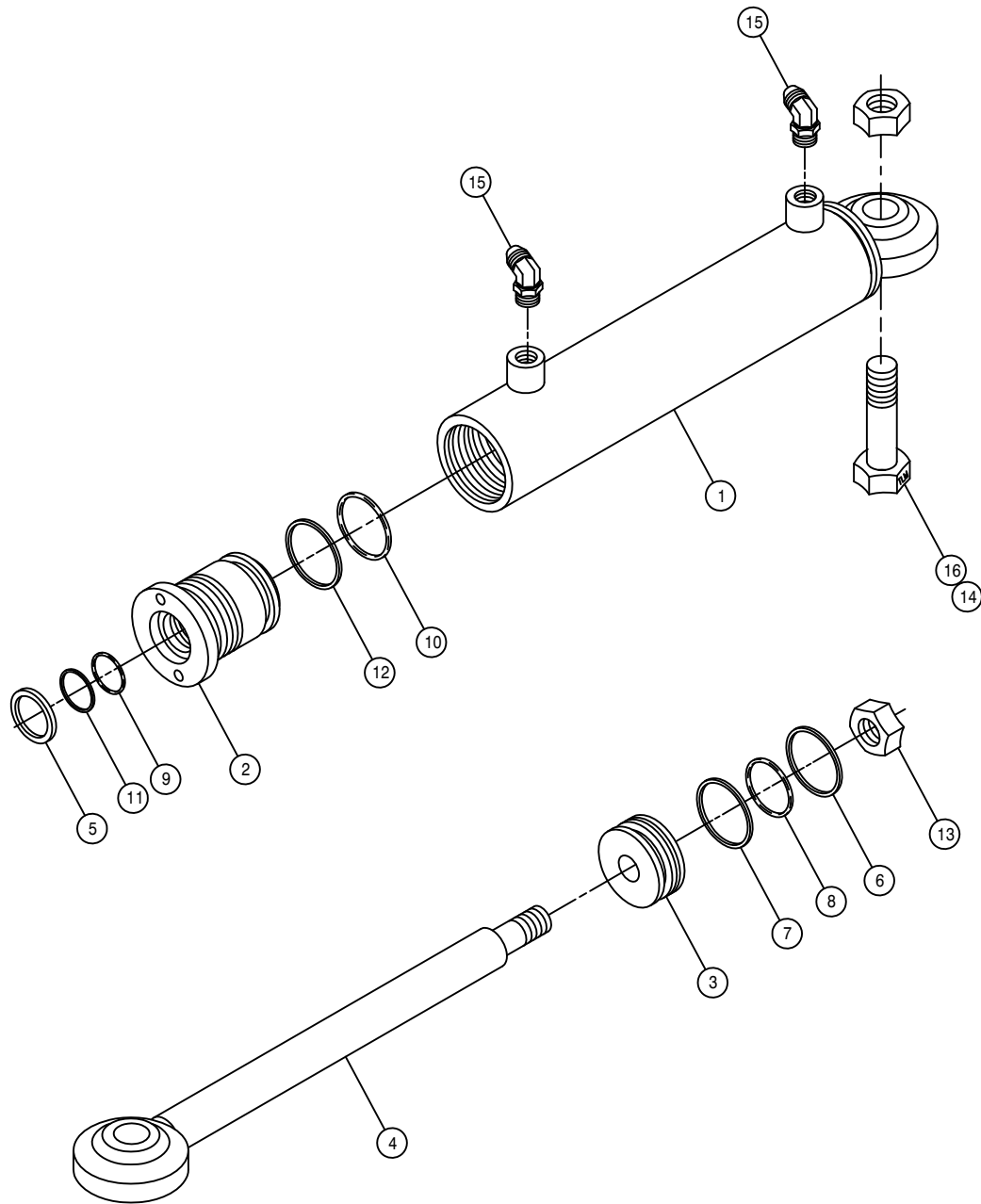

STEERING CYLINDER ASSEMBLY

DET.	QTY	PART NO.	DESCRIPTION
1	1	620089	STRG CYL TUBE WLD 1.5 X 6. 85
2	1	620109	GLAND HYD CYL 1.5 X .75 1985
3	1	620129	PISTON HYD CYL 1.5 X .5 1985
4	1	620148	STRG CYL SHAFT WLD
5	1	629028	WIPER, 10D X 3/4ID X 1/8
6	1	629616	SEAL, 1704-24 HT20550R POLYHON
7	1	629618	WEAR RING, 1.5" HYD CYL
8	1	870025	BUNA ORING 1 3/16 X 1 5/16
9	1	870210	BUNA ORING 3/4 X 1
10	1	870218	BUNA ORING 1 1/4 X 1 1/2
11	1	890210	BACKUP WASH 3/4 X1 HT2022
12	1	890218	BACKUP WASH1 1/4X1 1/2 HT2022
13	1	914009	1/2UNF HEX STOVER NUT
14	1	914010	5/8UNC HEX STOVER NUT
15	2	618338	9/16MJIC-45-1/4MNPT LBO
16	1	900336	5/8UNC X 2 1/2 HEX BOLT

NOTE: 1. 620080 - CYLINDER ASSEMBLY

2. 620998 - SEAL KIT

MAINFRAME ASSEMBLY

DET. QTY PART NO. DESCRIPTION

1	2	121028	JOURNAL BRG FOR 1IN SHFT1.0LG
2	1	473906	SPIRAL PIN, 1/2 X 2 1/2 LG
3	1	361382	FRT CROSSMBR WLD 250 X-11 92
4	1	361396	PIVOT PIN WLD,254 XMBR 94
5	1	471005	1/4 28 X 1/2 GREASE ZERK
6	1	659917	FRT MAINFRAME COVER PLT 95

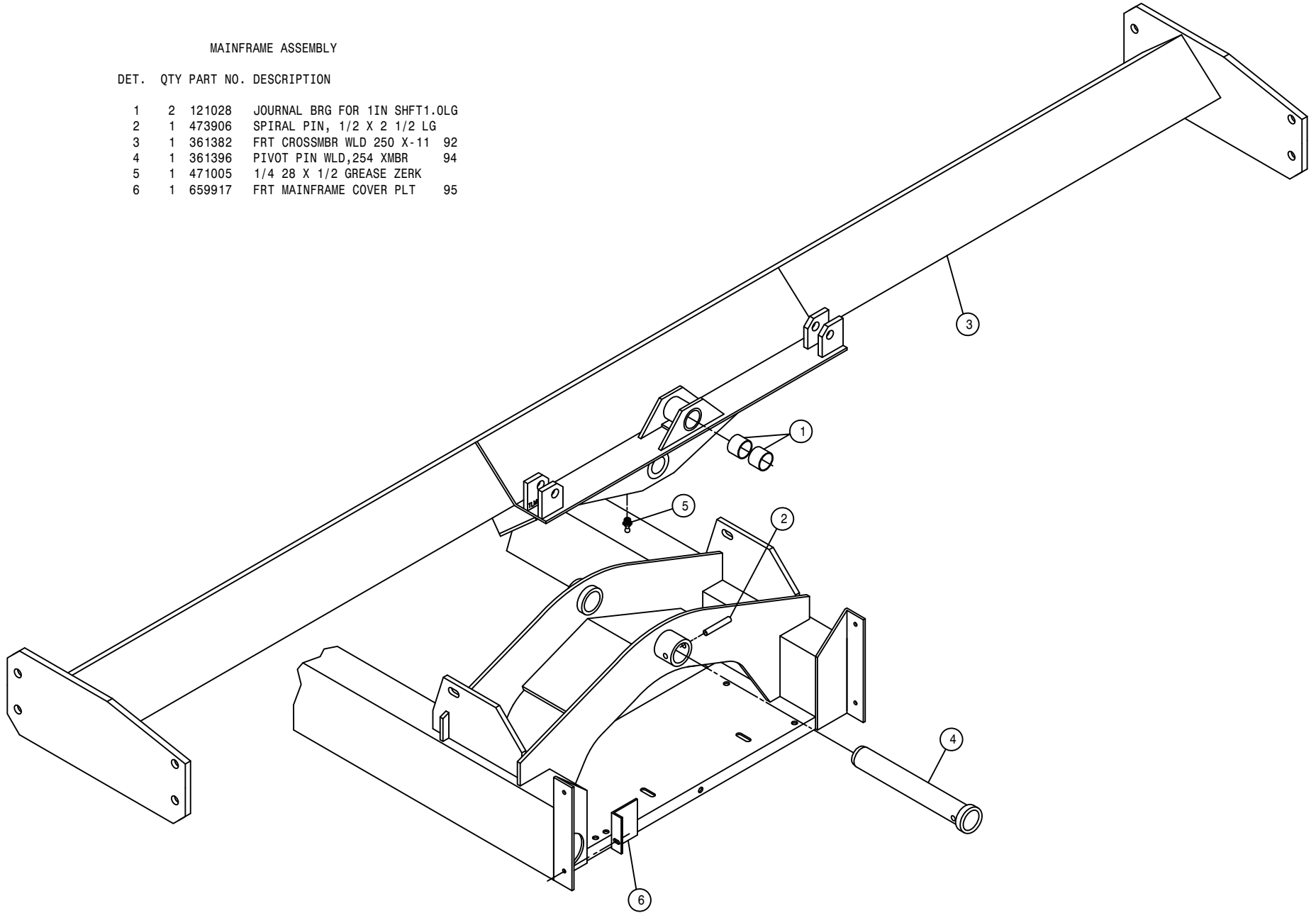

NOTES

FUEL TANK ASSEMBLY

DET. QTY PART NO. DESCRIPTION

1	1	291428	FUEL SENDER 19 IN.
2	5	473902	NO 8 X 1/2 PAN HD MET SC
3	1	501102	1/4 PIPE PLUG
4	2	501451	BLK PIPE EL 90DEG .25NPT
5	1	760149	FUEL TANK WLD 200-280 90
6	1	761200	GAS CAP
7	1	783303	1/4 NPT X 5/16 HOSE BARB, BRS
8	1	601400	HOSE, 3/8 X 112 FUEL LINE
9	2	914004	3/8UNC HEX STOVER NUT
10	1	760154	LH FUEL TNK MT WLD 200-280 90
11	2	760162	FUEL TANK BAND WLD 200-280 90
12	4	900264	1/2UNC X 1 1/4 HEX BOLT
13	1	783304	1/4 NPT X 3/8 HOSE BARB, BRS
14	1	601298	HOSE, 5/16 X 136 FUEL LINE
15	4	914008	1/2UNC HEX STOVER NUT
16	4	520120	HOSE CLAMP NO 4 STAINLESS
17	1	316281	FUEL STRAINER, IN-LINE, DIESEL
18	1	601393	HOSE, 3/8 X 3 FUEL LINE

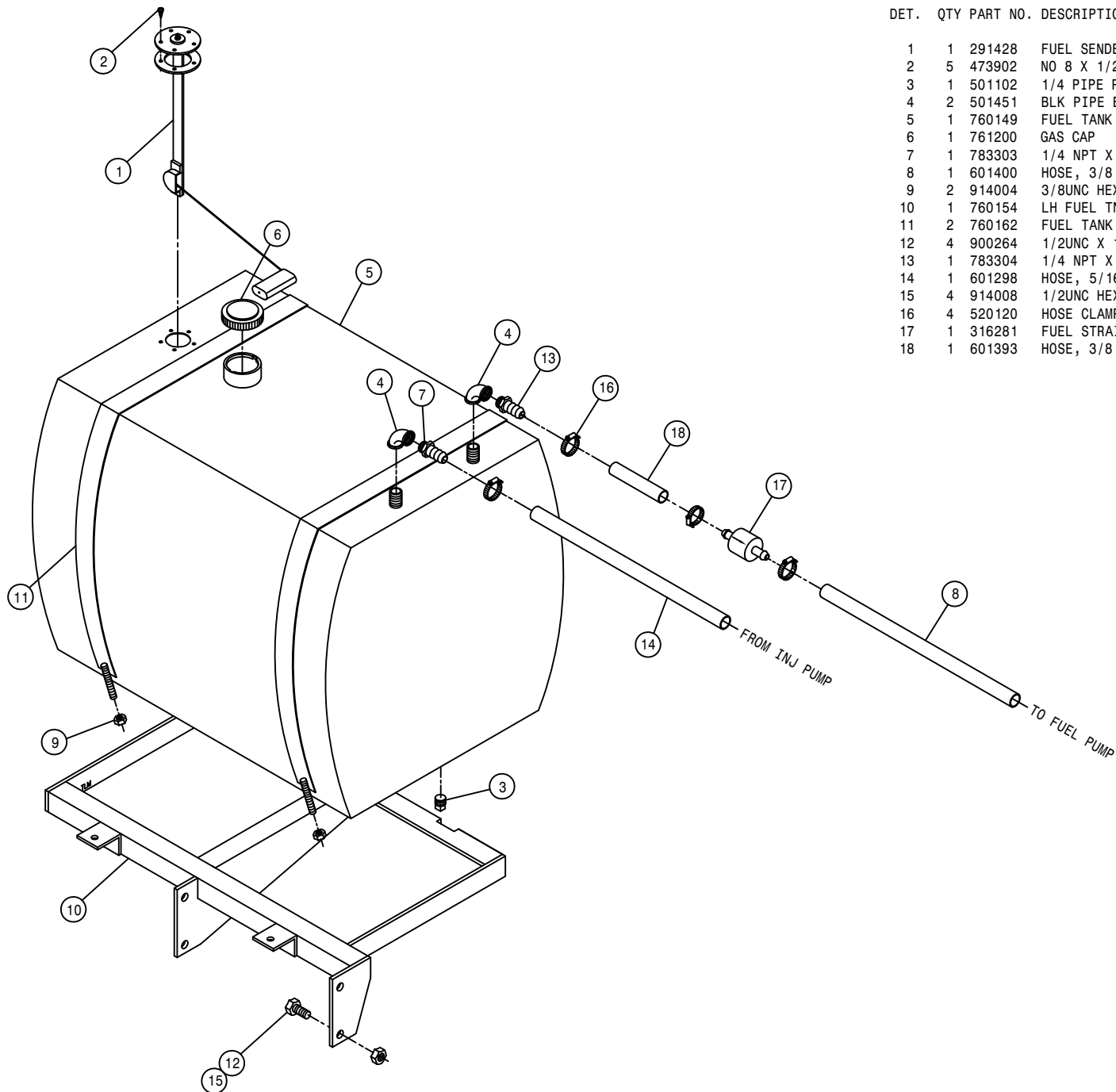

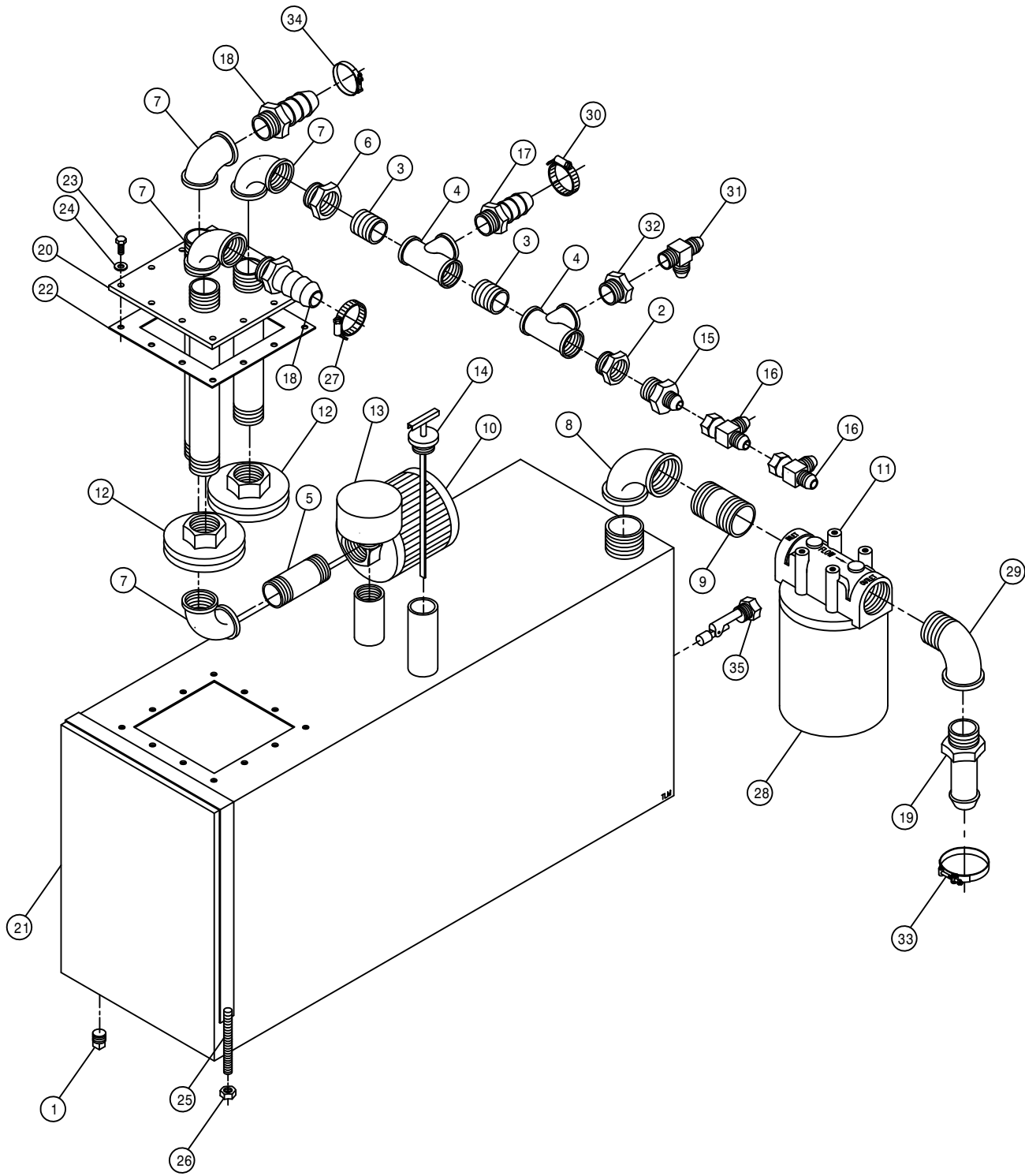

HYDRAULIC TANK ASSEMBLY

DET.	QTY	PART NO.	DESCRIPTION
	1	501102	1/4 PIPE PLUG
	2	504210	RED BUSH 3/4 NPT X 1/2 NPT
	3	504702	CLOSE NIPPLE .75NPT
	4	504955	BLK PIPE TEE .75NPT
	5	505203	BLK PIPE NIPPLE 1.00NPT-4.00
	6	505213	RED BUSH 1 X 3/4 BLK MAL
	7	505300	BLK PIPE EL 90DEG 1.00NPT
	8	506303	BLK PIPE EL 90DEG 1.25NPT
	9	506602	PIPE NIPPLE 1 1/4NPT-2 1/2
	10	605600	MICHIGAN RESERVOIR FILTER
	11	605601	GRESEN FILTER 10 MICRON 40GPM
	12	605603	LINE SUMP DIFFUSER
	13	611052	FILLER BREATHER 3/4NPT
	14	614453	DIPSTICK, 8IN
	15	618018	9/16MJIC-1/2MNPT ADPTR
	16	618486	9/16FJIC SW RUN TEE-9/16MJIC
	17	713220	HOSE BARB 3/4 NPT X 3/4
	18	714560	1NPT X 1 HOSE BARB
	19	715660	HOSE BARB 1 1/4NPT X 1 1/4
	20	760090	RECEIVER PLT WLD 8240
	21	760097	OIL TANK WLD 8240 1982
	22	763039	HYD MTR MTG PLT GSKT
	23	900064	5/16UNC X 3/4 HEX BOLT
	24	920001	5/16 SAE FLAT WASHER
	25	341360	OIL TANK STRAP WLD 8240 1982
	26	914004	3/8UNC HEX STOVER NUT
	27	520087	HOSE CLAMP NO 20 STAINLESS
	28	605602	FILT ELEMENT 10MICRON 40GPM
	29	506410	BLK PIPE ST EL 90DEG 1.25NPT
	30	520055	HOSE CLAMP NO 12 STAINLESS
	31	618520	1/4MNPT RUN TEE-9/16MJIC
	32	504001	RED BUSH 3/4 X 1/4 BLK MAL
	33	520132	1.62/1.87 T-BOLT HOSE CLAMP
	34	520138	1.00 T-BOLT HOSE CLAMP
	35	470290	LIQUID LEVEL SWITCH, 1/2MNPT

CAB ASSEMBLY

DET.	QTY	PART NO.	DESCRIPTION
1	1	290107	GROUND CABLE,8" X 4GA .406LUGS
2	4	311051	RUBBER MOUNT, RB3-350
3	4	311052	SNUBBING WASHER FOR 311051
4	24	193037	STICKERTITE 1/8 X 3/4
5	25	193044	WINDOW WEATHERSTRIP 94
6	25	193045	LOCK STRIP FOR 193044 94
7	13	192001	FILLR STRIP FOR WEATHERSTRIP
8	13	193018	2 P/C SELF SEAL WEATHERSTRIP
9	1	200019	.25 SCH 40BP X 1.00 LG C/L
10	1	202037	WINDSHIELD WIPER SPACER
11	1	290412	DIMMER SWITCH
12	1	290417	18" WIPER BLADE
13	4	900343	5/8UNC X 4 1/2 HEX BOLT
14	1	342100	CAB WLD 254-284 94
15	1	342145	KICK PANEL, 254 CAB 94
16	1	342150	CAB ROOF WLD, 284 94
17	1	342180	HEADLINER KPR ANGLE,284CAB 94
18	2	470067	RUBBER GROMMET 1/4 ID
19	2	470070	RUBBER GROMMET 3/8 ID
20	1	629728	FINISH PLUG FOR 2.12 HOLE
21	1	470229	IDENTIFICATION TIE, 3/4"
22	6	470100	3/8 INT TOOTH LOCK WASHER
23	13	470121	1/4UNC HEX FLANGE LOCK NUT
24	10	470122	1/4UNC X 1/2 FLANGE HEX BOLT
25	16	470212	1/4 X 5/8 BONDED SEALING WASH
26	16	470218	1/4UNC NUT J-TYPE CAGE CLIP
27	1	470222	GRAB HANDLE, BLACK MOULDED
28	12	472349	1/4 X 3/4 20THD-IN TEK TYPE
29	6	473779	10MM-1.50 HEX NUT
30	2	473910	1/4 X 1 1/2 PHIL HD SHT MTL S
31	2	650524	OUTSIDE REAR VIEW MIRROR
32	1	658008	WINDSHIELD WIPER MOTOR
33	1	658013	WIPER ARM
34	1	658014	FRONT CAB GLASS 94
35	1	658015	FRONT SIDE CAB/DOOR GLASS 94
36	2	658016	REAR SIDE CAB GLASS 94
37	1	658017	REAR CAB GLASS 94
38	8	900002	1/4UNC X 3/4 HEX BOLT
39	1	900005	1/4UNC X 1 1/2 HEX BOLT
40	4	914010	5/8UNC HEX STOVER NUT
41	2	903883	10-32 X 1/2 SLT RDHD MACH SCR
42	2	903889	10-32 X 3/4 SLT RDHD MACH SCR
43	4	470175	10-32 HEX FLANGE LOCK NUT
44	11	470118	1/4UNC X 3/4 FLANGE HEX BOLT
45	1	914000	1/4UNC HEX STOVER NUT
46	1	914004	3/8UNC HEX STOVER NUT
47	2	659704	FOAM, 2"THK X 2" WIDE X 42"LG
48	6	291603	WORKLAMP, SIDE MT 12V HALOGEN

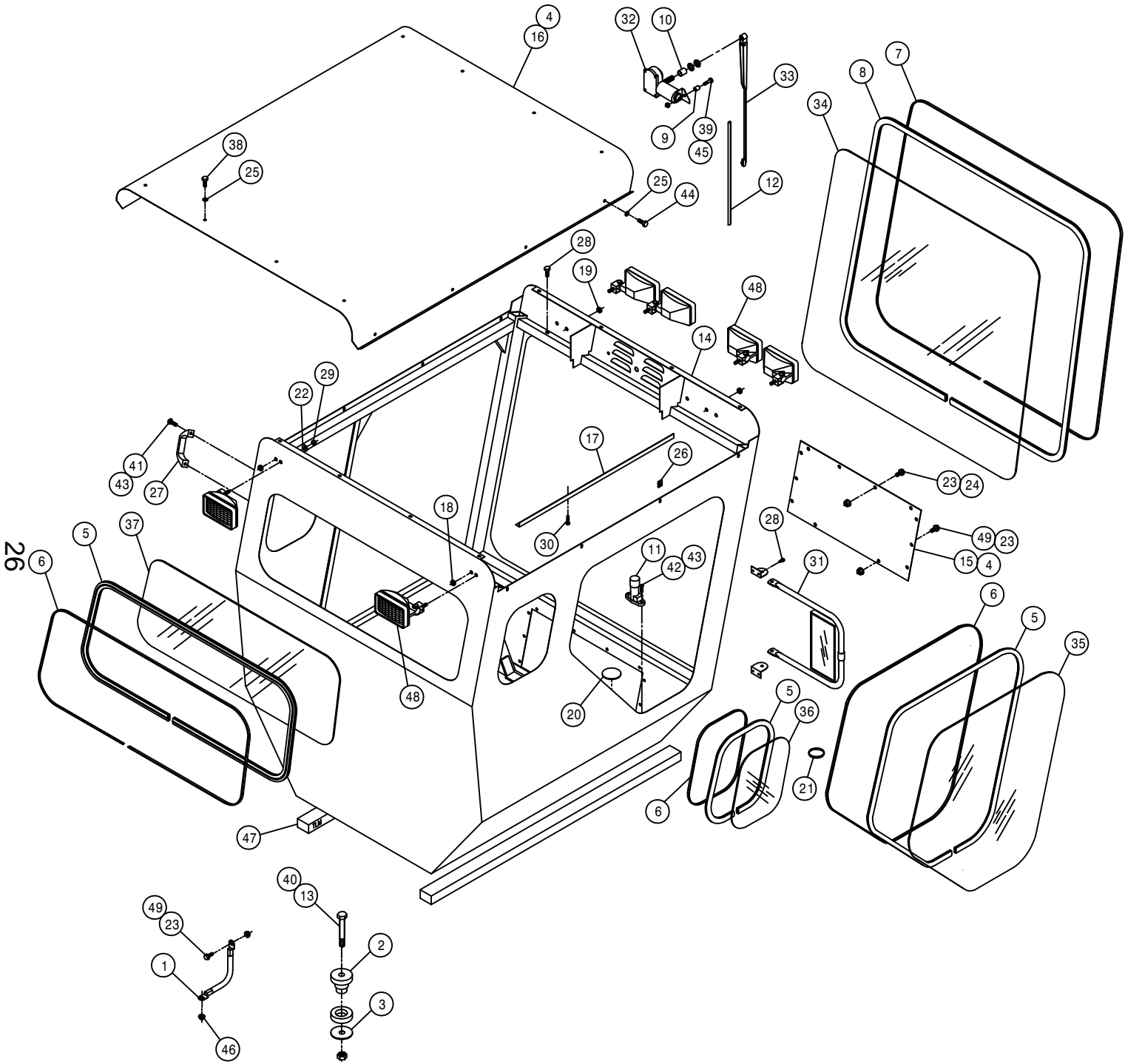

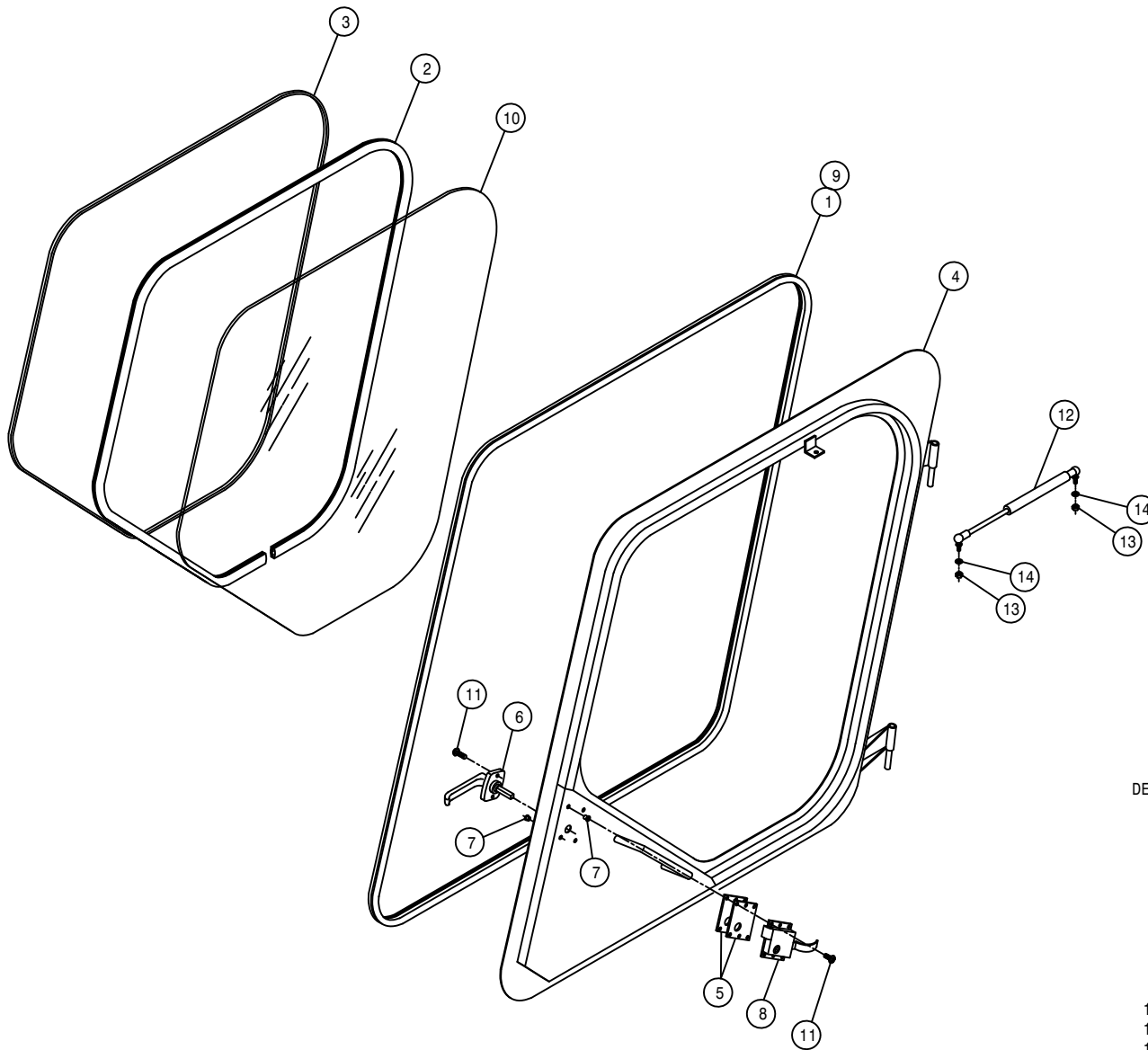

DOOR ASSEMBLY

DET. QTY PART NO. DESCRIPTION

1	12	193028	PUSH-ON TRIM SEAL RS-130-FX
2	9	193044	WINDOW WEATHERSTRIP 94
3	9	193045	LOCK STRIP FOR 193044 94
4	1	342153	LH DOOR WLD, 284 CAB 94
5	2	342163	CAB DOOR LATCH SHIM, .06 94
6	1	342217	DOOR HANDLE, 254/284 CAB 94
7	6	470165	10-32 NUTSERT .020-.100 MATL
8	1	470219	CAB LOCK, LH #55
9	2	485052	POP RIVET 1/8 X 3/8
10	1	658015	FRONT SIDE CAB/DOOR GLASS 94
11	6	903710	10-32X5/8 PHIL PANHD MACH SCR
12	1	470221	GAS SPRING, 60LB 3.5 STROKE
13	2	910002	5/16UNC HEX NUT
14	2	920501	5/16 LOCK WASHER

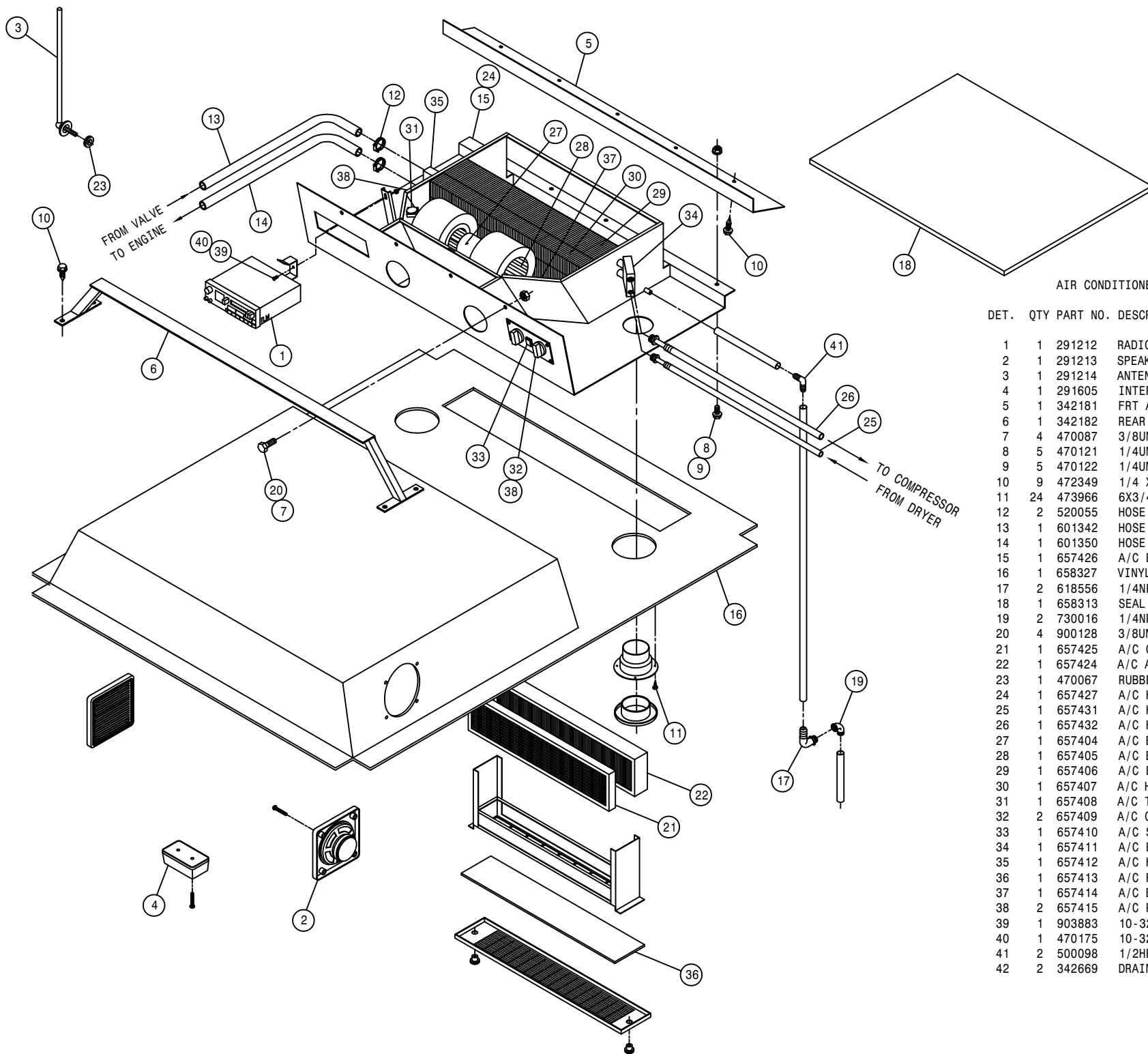

AIR CONDITIONER ASSEMBLY

DET. QTY PART NO. DESCRIPTION

1	1	291212	RADIO	94
2	1	291213	SPEAKERS (PAIR)	94
3	1	291214	ANTENNA	94
4	1	291605	INTERIOR LIGHT W/SWITCH	
5	1	342181	FRT A/C BLOWER MT ANG, CAB	94
6	1	342182	REAR A/C BLOWER MT WLD,CAB	94
7	4	470087	3/8UNC HEX FLANGE LOCK NUT	
8	5	470121	1/4UNC HEX FLANGE LOCK NUT	
9	5	470122	1/4UNC X 1/2 FLANGE HEX BOLT	
10	9	472349	1/4 X 3/4 20THD-IN TEK TYPE	
11	24	473966	6X3/4 PHIL FLT HD SHT MTL SCR	
12	2	520055	HOSE CLAMP NO 12 STAINLESS	
13	1	601342	HOSE, 5/8 X 192 HEATER	
14	1	601350	HOSE, 5/8 X 160 HEATER	
15	1	657426	A/C EVAPORATOR/HEATER, 284 MCC	
16	1	658327	VINYL HEAD LINER	99
17	2	618556	1/4NPT-90-1/2 HOSE BARB,POLY	
18	1	658313	SEAL, AIR CONDITIONER	94
19	2	730016	1/4NPT ST EL, 90 DEG POLY	
20	4	900128	3/8UNC X 3/4 HEX BOLT	
21	1	657425	A/C CHARCOAL AIR FILTER	MCC
22	1	657424	A/C AIR FILTER	MCC
23	1	470067	RUBBER GROMMET 1/4 ID	
24	1	657427	A/C HOSE KIT, EVAP 284, 99	MCC
25	1	657431	A/C HOSE ASSY, 5/16 X 173	MCC
26	1	657432	A/C HOSE ASSY, 1/2 X 190.	MCC
27	1	657404	A/C BLOWER MOTOR, 12V	MCC
28	1	657405	A/C BLOWER WHEEL W/CLIP	MCC
29	1	657406	A/C EVAPORATOR COIL	MCC
30	1	657407	A/C HEATER COIL	MCC
31	1	657408	A/C THERMOSTAT	MCC
32	2	657409	A/C CONTROL KNOB	MCC
33	1	657410	A/C SWITCH, PUSH ON-OFF	MCC
34	1	657411	A/C EXPANSION VALVE	MCC
35	1	657412	A/C HEATER VALVE,MOTORIZED	MCC
36	1	657413	A/C FILTER, RECIRCULATION	MCC
37	1	657414	A/C BLOWER DRIVE ASSY	MCC
38	2	657415	A/C POTENTIOMETER ASSY	MCC
39	1	903883	10-32 X 1/2 SLT RDHD MACH SCR	
40	1	470175	10-32 HEX FLANGE LOCK NUT	
41	2	500098	1/2HB-90-1/2 HOSE BARB, POLY	
42	2	342669	DRAIN HOSE KEEPER	

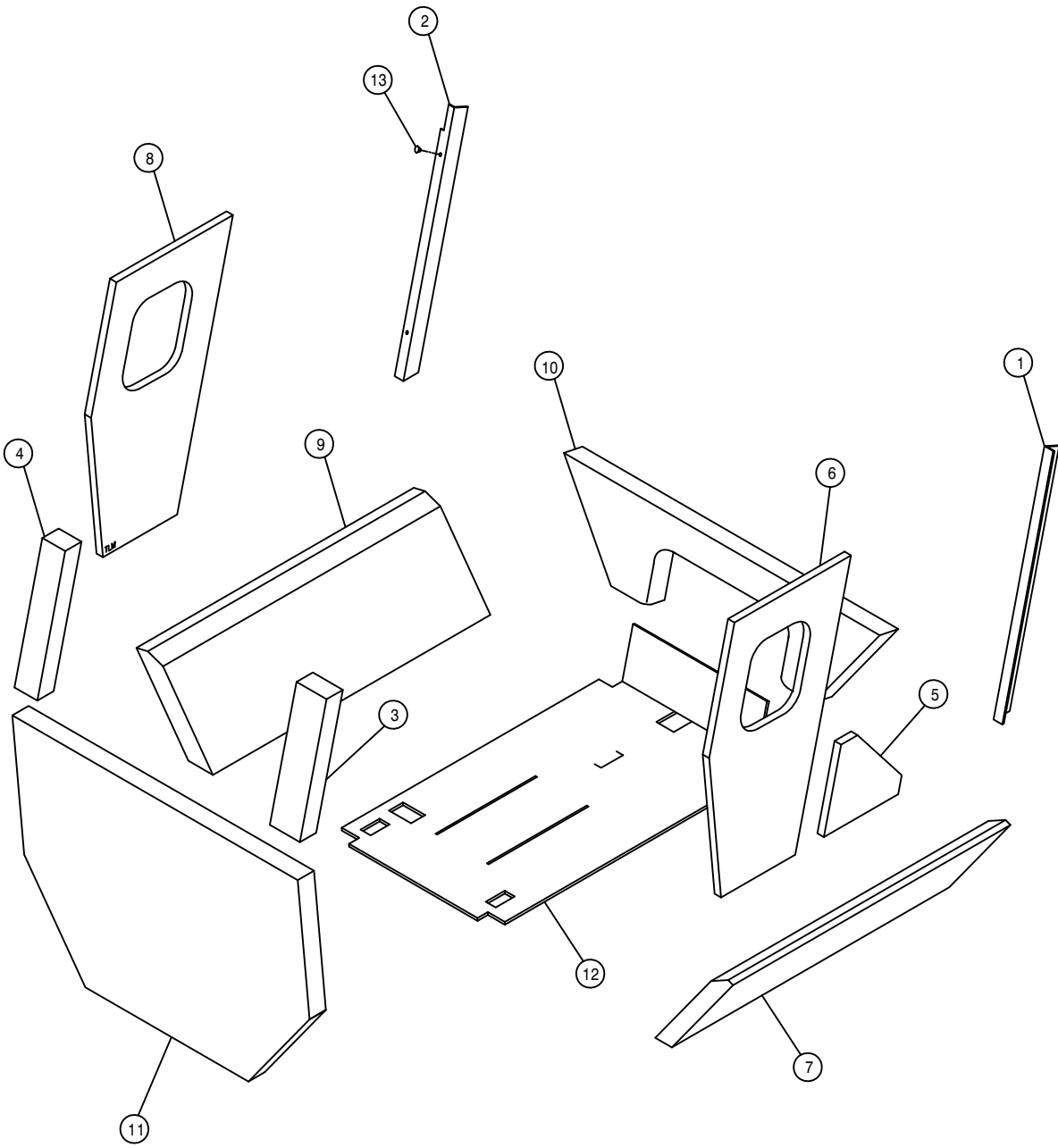

CAB FOAM

DET.	QTY	PART NO.	DESCRIPTION
1	1	658301	VINYL POST COVER, RH FRONT 94
2	1	658302	VINYL POST COVER, LH FRONT 94
3	1	658303	VINYL POST COVER, RH REAR 94
4	1	658304	VINYL POST COVER, LH REAR 94
5	1	658305	VINYL SIDE PANEL, RH 94
6	1	658306	VINYL SIDE PANEL, RH UPPER 94
7	1	658307	VINYL SIDE PANEL, RH LOWER 94
8	1	658308	VINYL SIDE PANEL, LH UPPER 94
9	1	658309	VINYL SIDE PANEL, LH LOWER 94
10	1	658310	VINYL FRONT COVER PANEL 94
11	1	658311	VINYL REAR COVER PANEL 94
12	1	658315	CAB FLOORMAT 254/284 95
13	2	470225	TRIM CLIP, 11/16 BLK NYL HEAD

STEERING POST ASSEMBLY

DET. QTY PART NO. DESCRIPTION

DET.	QTY	PART NO.	DESCRIPTION
1	1	221001	CONN LINK CLIP TYPE RC50
2	1	291088	FLASHER / TURN SIGNAL SWITCH
3	1	342165	STRG POST WLD, 284 CAB 94
4	1	342173	STRG POST ADJ PIN, 284 CAB 94
5	1	342174	STRG POST ADJ PIN LEVER WLD94
6	1	342177	STRG POST COVER, 284 CAB 94
7	1	342178	UPR STRG MTR HSG COVER 94
8	1	342179	LWR STRG MTR HSG COVER 94
9	2	390318	INDICATOR LIGHT, RED
10	4	470086	1/4UNC NUTSERT .020-.100MATL
11	1	470157	13/16-20UNEF HEX NUT STRG WHL
12	1	473939	ROLL PIN, 3/16DIA X 7/8
13	1	659291	KNOB, 1" RND, BLK, 3/8-16
14	1	749150	STRG MTR NON-LOAD REACT 1008
15	1	749178	STRG COLUMN 2.5IN LONG
16	1	749294	STEERING WHEEL, VIP 14"
17	1	749295	STRG WHL CAP W/HAGIE EMBLEM
18	13	903708	1/4UNC X 1/2 PHIL PNHD MACHSCR
19	1	914002	5/16UNC HEX STOVER NUT
20	1	914008	1/2UNC HEX STOVER NUT
21	1	900271	1/2UNC X 3 1/4 HEX BOLT
22	4	920001	5/16 SAE FLAT WASHER
23	4	920002	3/8 SAE FLAT WASHER
24	4	900130	3/8UNC X 1 1/4 HEX BOLT
25	4	618496	9/16MJIC-45-3/4MOR LBO
26	1	482131	3/4 X 1 3/4 COMPRSN SPRING
27	1	470121	1/4UNC HEX FLANGE LOCK NUT

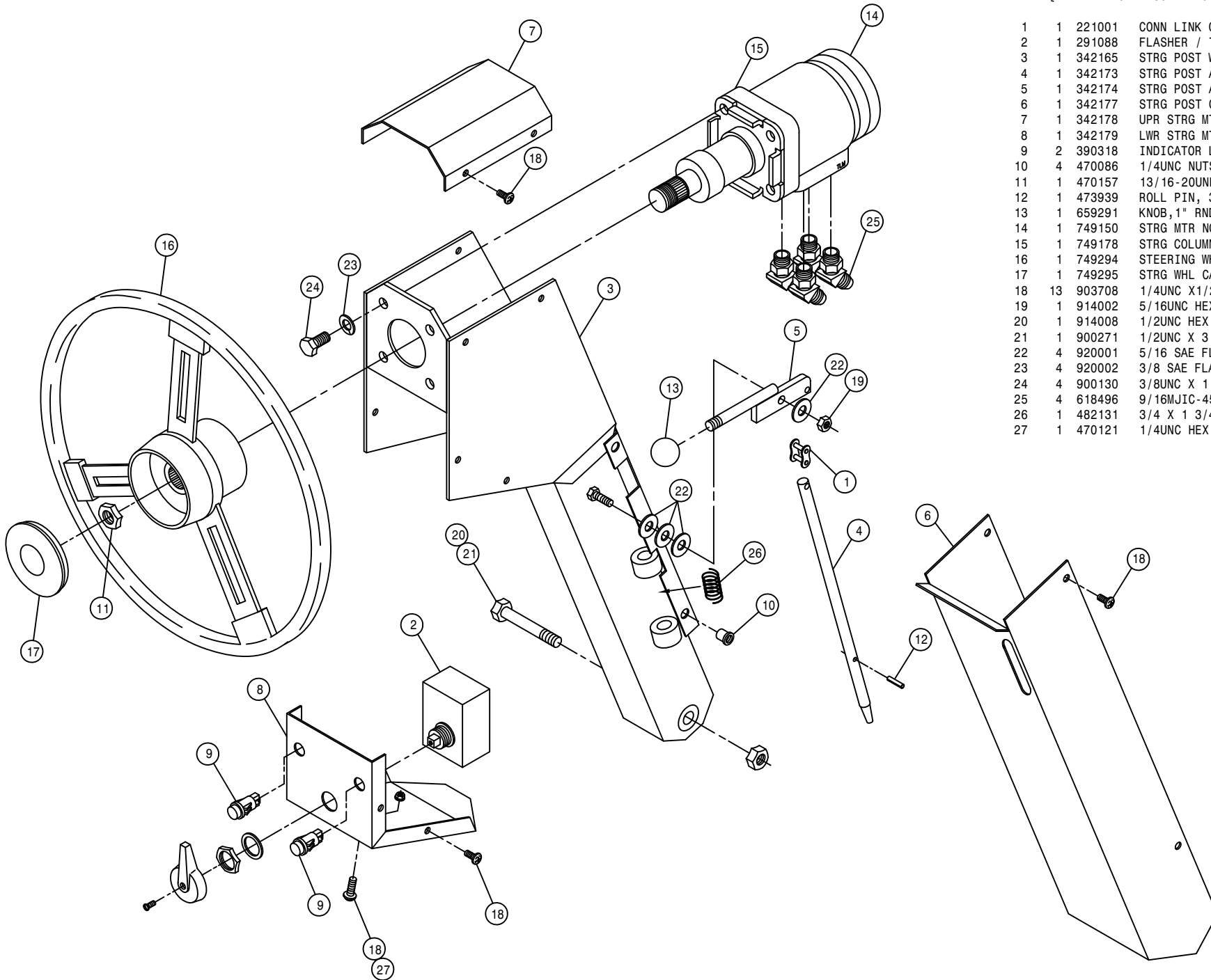

30

189030

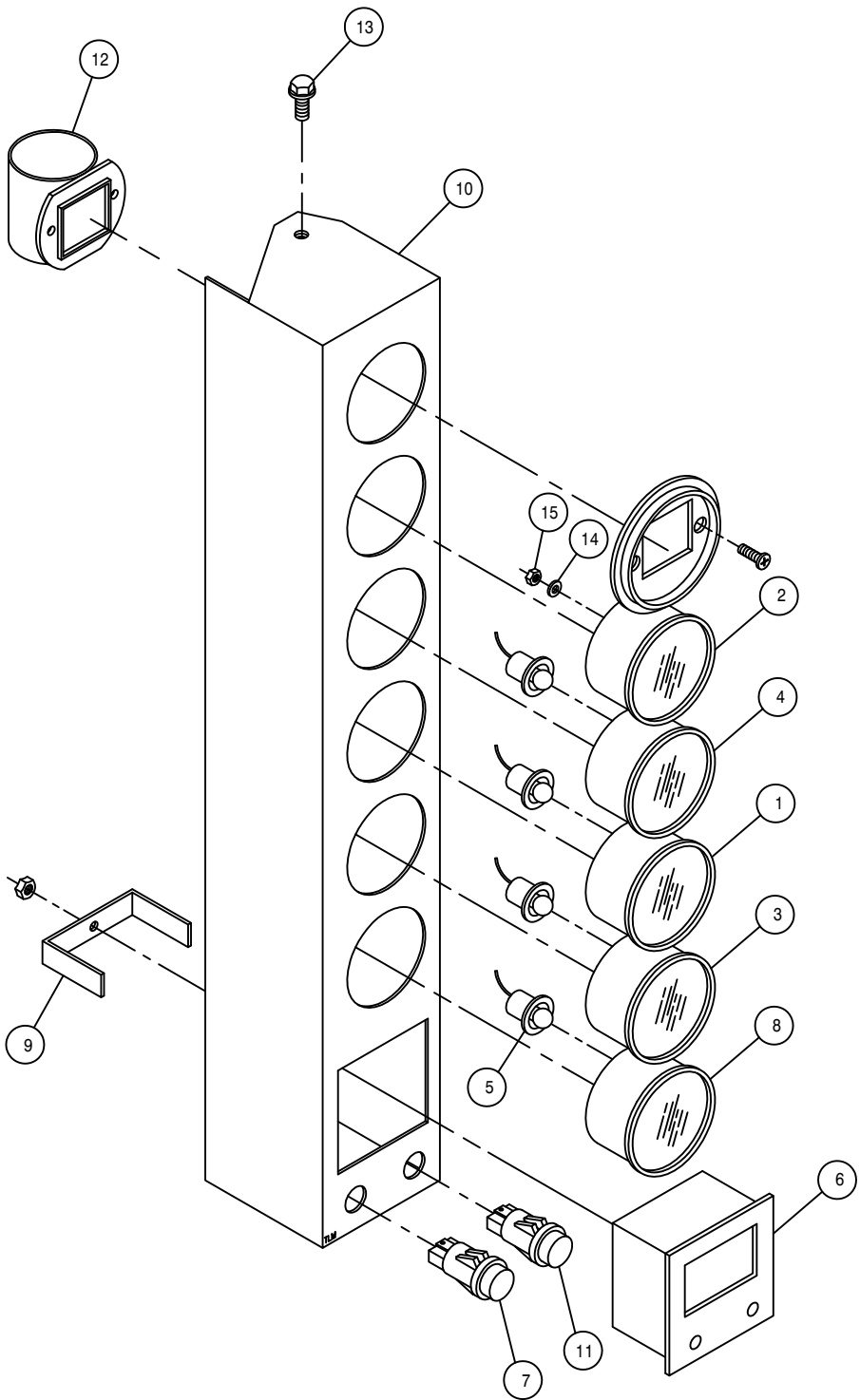

INSTRUMENT PANEL ASSEMBLY

DET. QTY PART NO. DESCRIPTION

1	1	290401	FUEL GAUGE FOR 2.125 DIA HOLE
2	1	291203	HOUR METER, 12/24VDC BLACK BEZ
3	1	291609	OIL PRESS GAUGE, 80PSI
4	1	291611	VOLTMETER, 8V TO 18V DC
5	4	291612	LIGHT KIT FOR 2" GAUGE
6	1	291635	DIGITAL MPH/RPM INDICATOR
7	1	291638	INDICATOR LIGHT, GREEN
8	1	314436	TEMP GA 100-280 DEG LIGHTED
9	1	342068	DIGITAL MPH/RPM IND KEEPER 94
10	1	342186	INSTRU HSNGLD, 284 CAB 94
11	1	390318	INDICATOR LIGHT, RED
12	1	314901	FILTER MINDER AIR RESTRICT GA
13	2	470122	1/4UNC X 1/2 FLANGE HEX BOLT
14	8	473802	# 8 INT TOOTH STAR WASHER
15	8	910024	8-32 HEX NUT

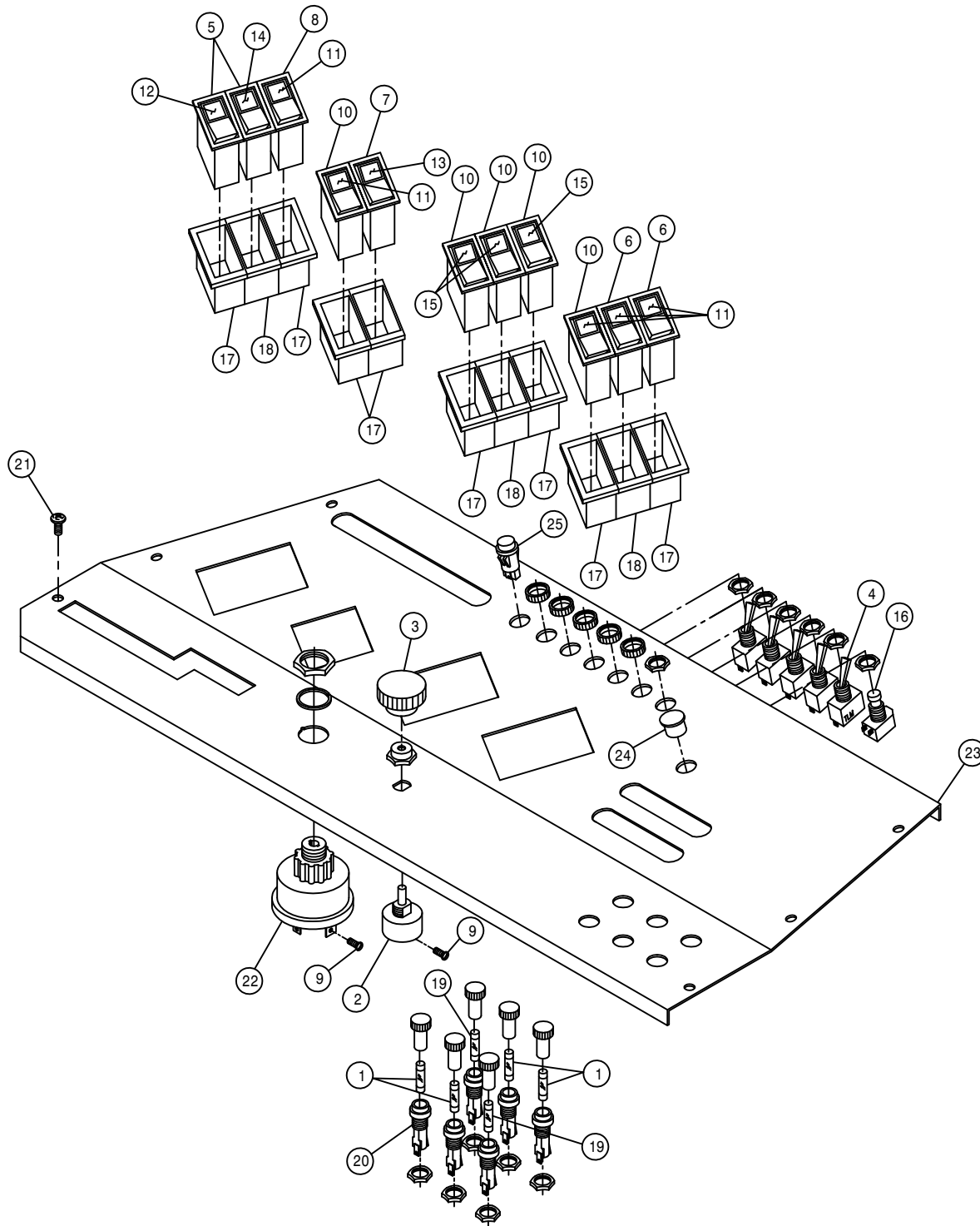

CONSOLE PANEL ASSEMBLY

DET.	QTY	PART NO.	DESCRIPTION
1	4	291602	FUSE 10 AMP
2	1	291606	ROTARY HEADLAMP SWITCH
3	1	291607	SWITCH KNOB FOR 291606
4	5	291608	TOGGLE SWITCH, ON-OFF, UNLIT
5	2	291622	SWITCH, 1P ON/OFF 511-003
6	2	291623	SWITCH, 2P ON/OFF 511-015
7	1	291624	SWITCH, 2P(ON)/OFF 511-130
8	1	291625	SWITCH, 2P ON/ON 511-108
9	2	903844	8-32 X 1/2 SLT RD HD MACH SCR
10	5	291627	SWITCH, 2P(ON)OFF(ON) 511-058
11	5	291628	LENS, GREEN 596-650
12	1	291629	LENS, WIPER
13	1	291630	LENS, WINDSHIELD WASHER
14	1	291631	LENS, HAZARD
15	3	291632	LENS, DIRECTION INDICATOR
16	1	291639	PUSHBUTTON SWITCH, ON/OFF SPST
17	8	293246	END BEZEL
18	3	293247	CENTER BEZEL
19	2	298004	20 AMP FUSE SFE 20
20	6	298011	FUSE HOLDER
21	6	903708	1/4UNC X1/2 PHIL PNHD MACHSCR
22	1	321021	IGN SWITCH, NON-SEALED
23	1	342189	CONSOLE COVER PNL, 284 CAB 94
24	1	470224	SNAP PLUG, BLK NYL, .50 DIA
25	1	390318	INDICATOR LIGHT, RED

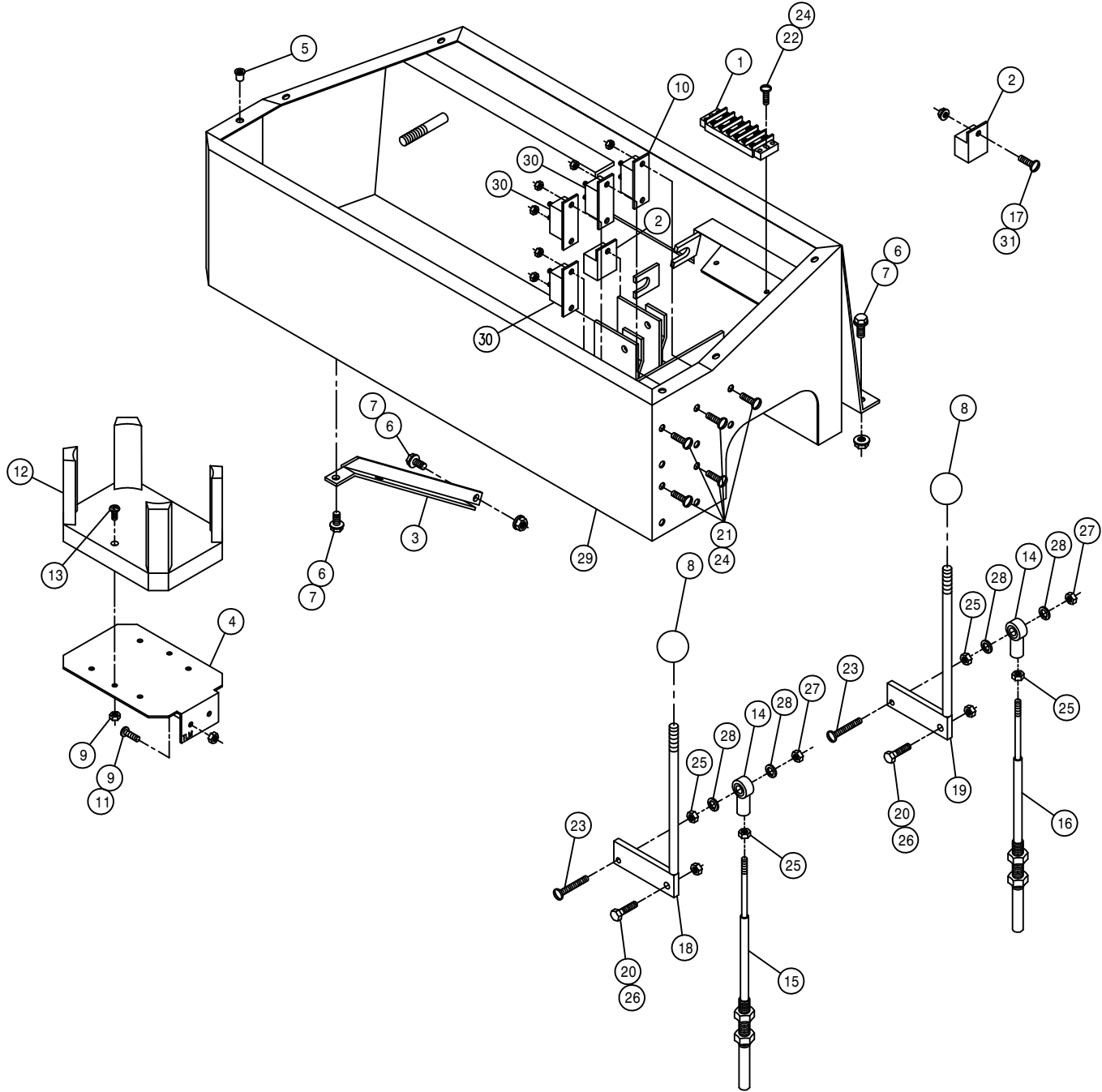

CONSOLE ASSEMBLY

DET.	QTY	PART NO.	DESCRIPTION
	1	293093	TERMINAL BLOCK 6 POS - 2 ROW
	2	291640	RELAY, 12V 20/30AMP BOSCH
	3	342282	CONSOLE BRACE 254/284 95
	4	342216	DRINK HOLDER MT BRKT 94
	5	470086	1/4UNC NUTSERT .020-.100MATL
	6	470118	1/4UNC X 3/4 FLANGE HEX BOLT
	7	470121	1/4UNC HEX FLANGE LOCK NUT
	8	659291	KNOB, 1" RND, BLK, 3/8-16
	9	470175	10-32 HEX FLANGE LOCK NUT
	10	291024	CIRCUIT BREAKER, 40AMP, INLINEMT
	11	903710	10-32X5/8 PHIL PANHD MACH SCR
	12	470214	SPILLMASTER DRINK HOLDER
	13	903710	10-32X5/8 PHIL PANHD MACH SCR
	14	473921	BALL JOINT NO 10-32 THD
	15	785063	CTRL CABLE 10-32 2IN X 42 LG
	16	785064	CTRL CABLE 10-32 2IN X 53 LG
	17	903844	8-32 X 1/2 SLT RD HD MACH SCR
	18	785070	SOLU PRESS CTRL LEVER WLD 94
	19	785073	AGIT CTRL LEVER WLD 94
	20	900003	1/4UNC X 1" HEX BOLT
	21	903812	6-32 X 1/2 SLT RD HD MACH SCR
	22	903814	6-32 X 3/4 SLT RD HD MACH SCR
	23	903893	10-32 X 1" SLT RD HD MACH SCR
	24	910022	6-32 HEX NUT
	25	910027	10-32 HEX NUT
	26	914000	1/4UNC HEX STOVER NUT
	27	914027	10-32 HEX STOVER NUT
	28	920510	#10 LOCK WASHER
	29	342191	CONSOLE WLD, 284 CAB 94
	30	291197	CIRCUIT BREAKER, 30AMP, INLINEMT
	31	910024	8-32 HEX NUT

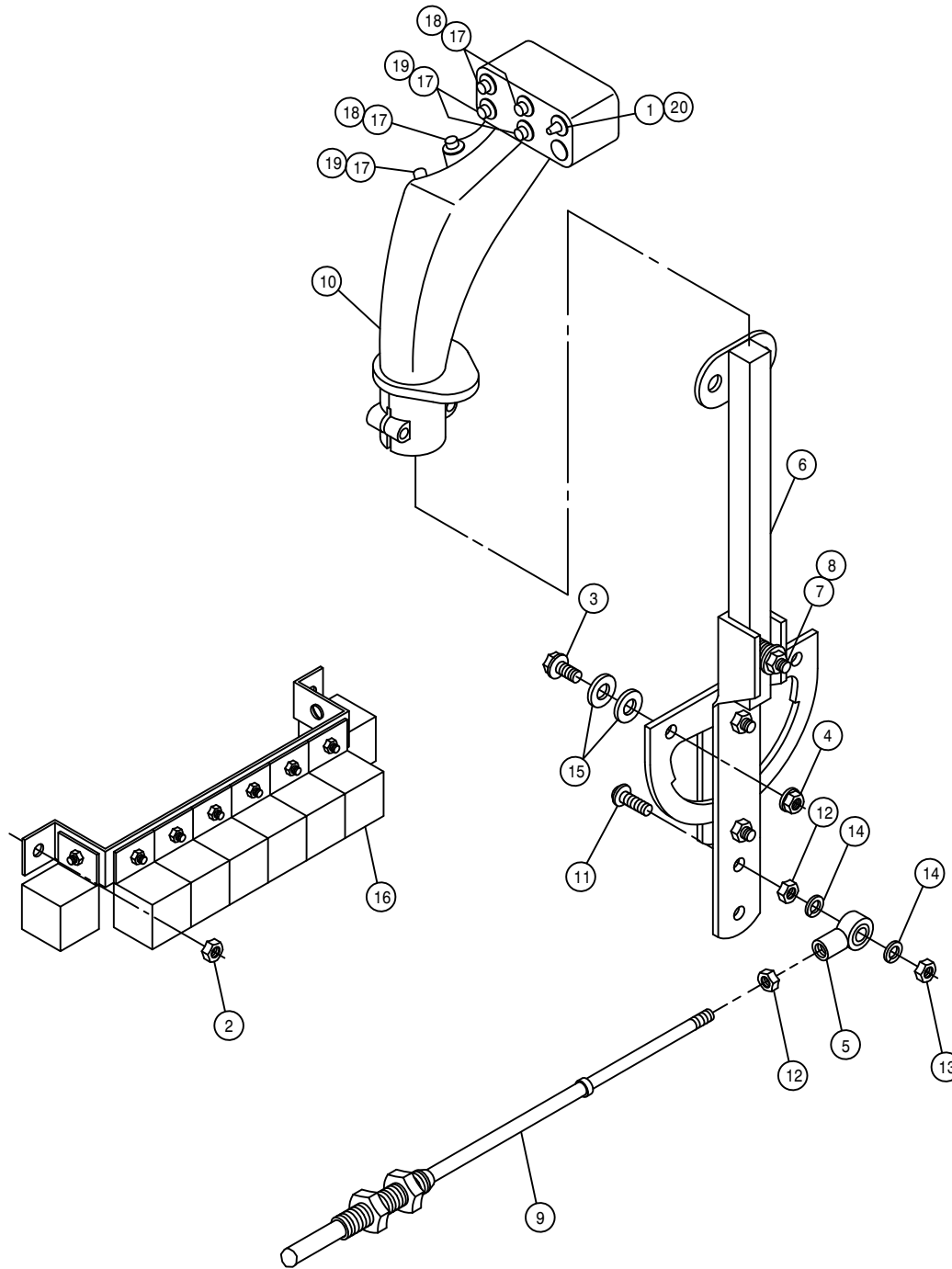

HYDROSTATIC LEVER ASSEMBLY

DET.	QTY	PART NO.	DESCRIPTION
1	1	291653	SWITCH, TOG SPDT 3POS STAT
2	2	470175	10-32 HEX FLANGE LOCK NUT
3	2	470118	1/4UNC X 3/4 FLANGE HEX BOLT
4	2	470121	1/4UNC HEX FLANGE LOCK NUT
5	1	473921	BALL JOINT NO 10-32 THD
6	1	606907	HYDST CTRL LEVER ASSY 204-284
7	1	900005	1/4UNC X 1 1/2 HEX BOLT
8	1	914000	1/4UNC HEX STOVER NUT
9	1	785003	CTRL CABLE 10-32 4IN X 112 LG
10	1	785078	FASSE EZ-3 CTRL HANDLE,284 96
11	1	903893	10-32 X 1" SLT RD HD MACH SCR
12	2	910027	10-32 HEX NUT
13	1	914027	10-32 HEX STOVER NUT
14	2	920510	#10 LOCK WASHER
15	4	920000	1/4 SAE FLAT WASHER
16	6	291640	RELAY, 12V 20/30AMP BOSCH
17	6	291650	SWITCH,SPDT MOM MICRO
18	3	291651	SWITCH BOOT, GRAY -FOR 291650
19	3	291652	SWITCH BOOT, RED -FOR 291650
20	1	291654	SWITCH BOOT, BLACK-FOR 291653

THROTTLE LEVER ASSEMBLY

DET. QTY PART NO. DESCRIPTION

1	1	499001	SPRING HYDRO CONTROL
2	1	785007	KNOB,1 3/16" BALL,RED,3/8-16
3	1	785046	FRICTION DISC 3-333 X .38
4	1	785066	CTRL CABLE 10-32 4IN X 129 IN
5	1	785067	THROT LEVER WLD,GAS/DIESEL 94
6	1	903893	10-32 X 1" SLT RD HD MACH SCR
7	2	910027	10-32 HEX NUT
8	1	914004	3/8UNC HEX STOVER NUT
9	1	914027	10-32 HEX STOVER NUT
10	1	920002	3/8 SAE FLAT WASHER
11	2	920510	#10 LOCK WASHER
12	1	473921	BALL JOINT NO 10-32 THD

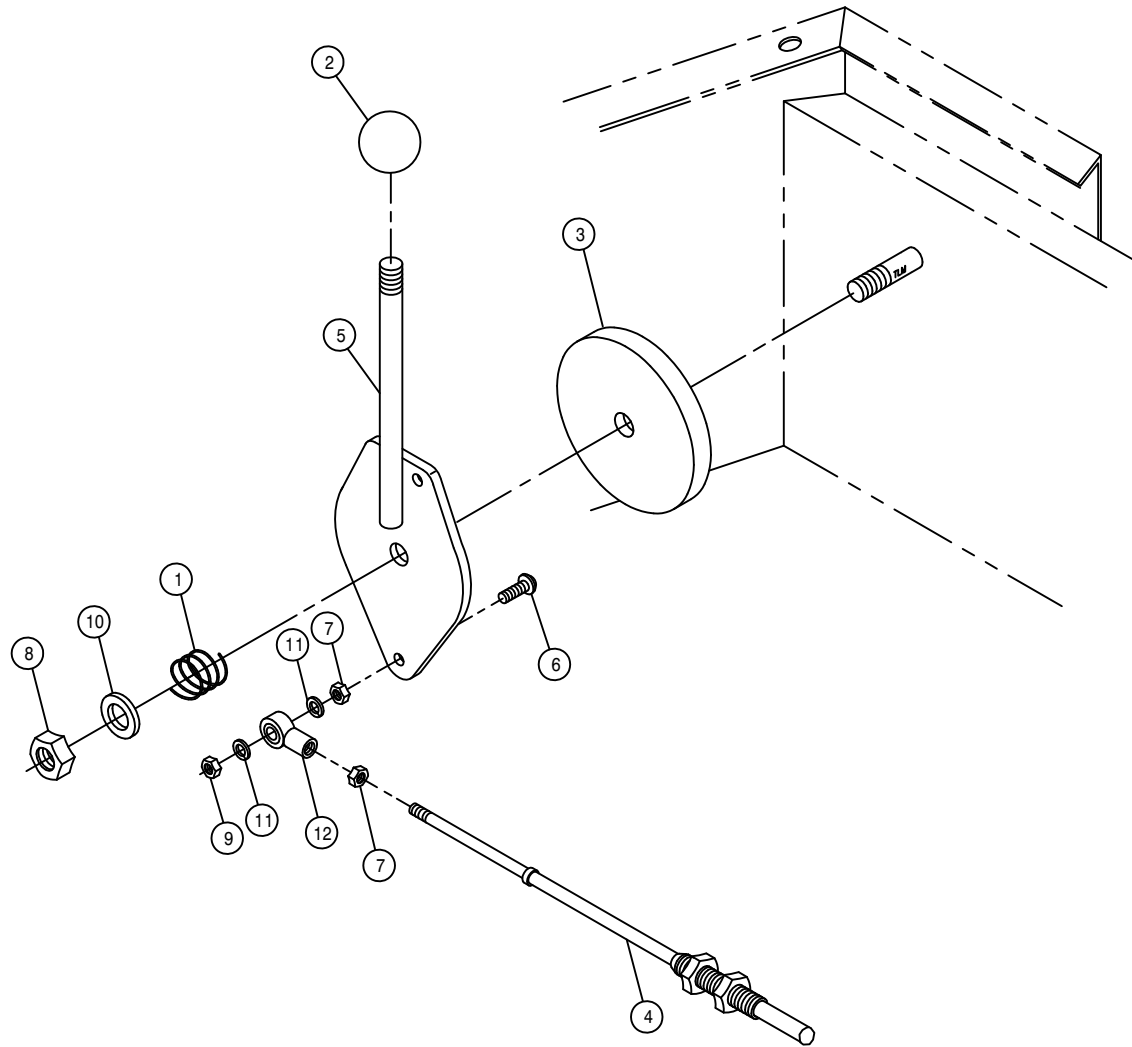

BRAKE LEVER ASSEMBLY

DET.	QTY	PART NO.	DESCRIPTION
1	1	826108	BRAKE LEVER ASSY
2	1	826138	PARK BRAKE SWITCH FOR 826108
3	1	826139	PARK BRAKE SWITCH SCR
4	1	826140	PARK BRAKE SWITCH PIN
5	2	826926	190 IN BRAKE CABLE
6	4	900064	5/16UNC X 3/4 HEX BOLT
7	1	900067	5/16UNC X 1 1/2 HEX BOLT
8	5	914002	5/16UNC HEX STOVER NUT
9	1	291636	BUZZER, 12V ELECTRONIC
10	1	193038	DUAL LOCK 1IN SJ3541 TYPE 400
11	1	193039	DUAL LOCK 1IN SJ3542 TYPE 400
12	2	826930	BRAKE CABLE EXTEN 20IN470
13	1	826981	BRAKE CABLE EXT BRKT 8250
14	2	473808	1/4UNC-3/4ID-1 1/4 U-BOLT
15	4	470135	CLEVIS PIN, 5/16 X 7/8 LG
16	4	472008	COTTER PIN 5/32 X 1
17	4	914000	1/4UNC HEX STOVER NUT

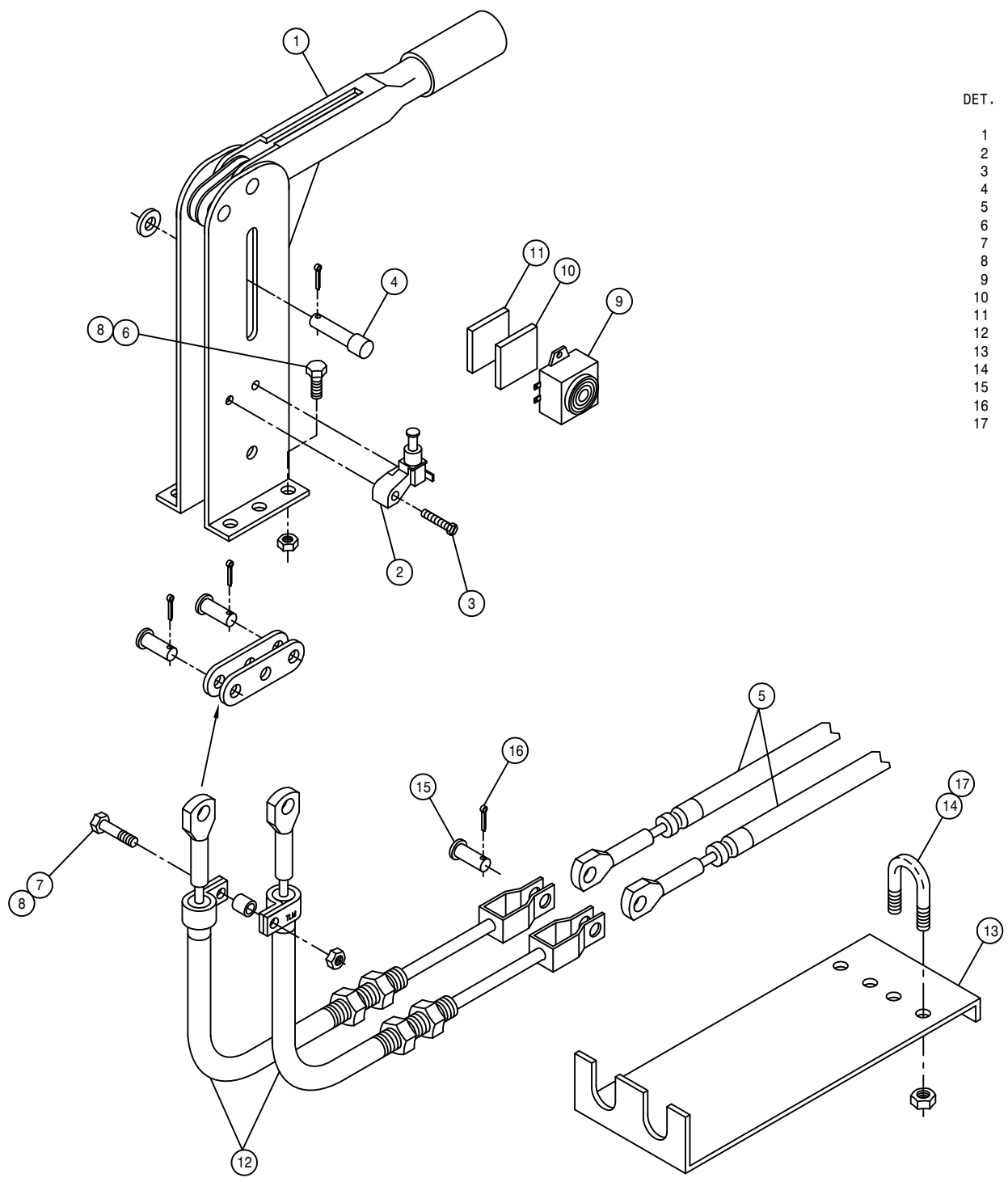

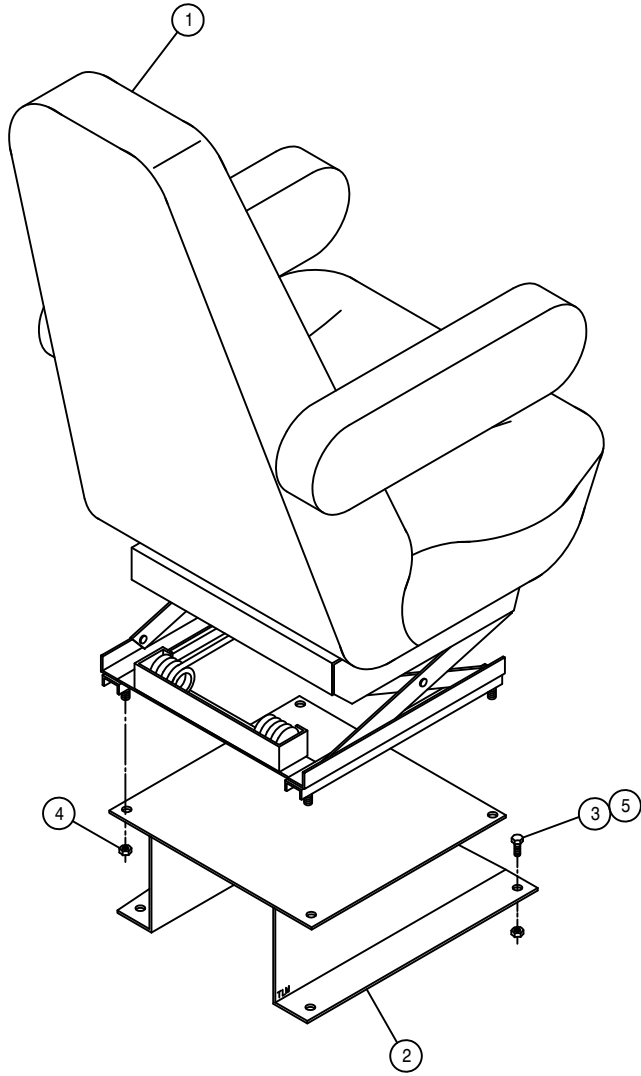

SEAT ASSEMBLY

DET. QTY PART NO. DESCRIPTION

1	1	330022	SEAT, MAGNUM-100 AIR SUSPEND95	
2	1	342090	SEAT MT WELD, 254/284	95
3	4	900129	3/8UNC X 1" HEX BOLT	
4	4	914002	5/16UNC HEX STOVER NUT	
5	4	914004	3/8UNC HEX STOVER NUT	

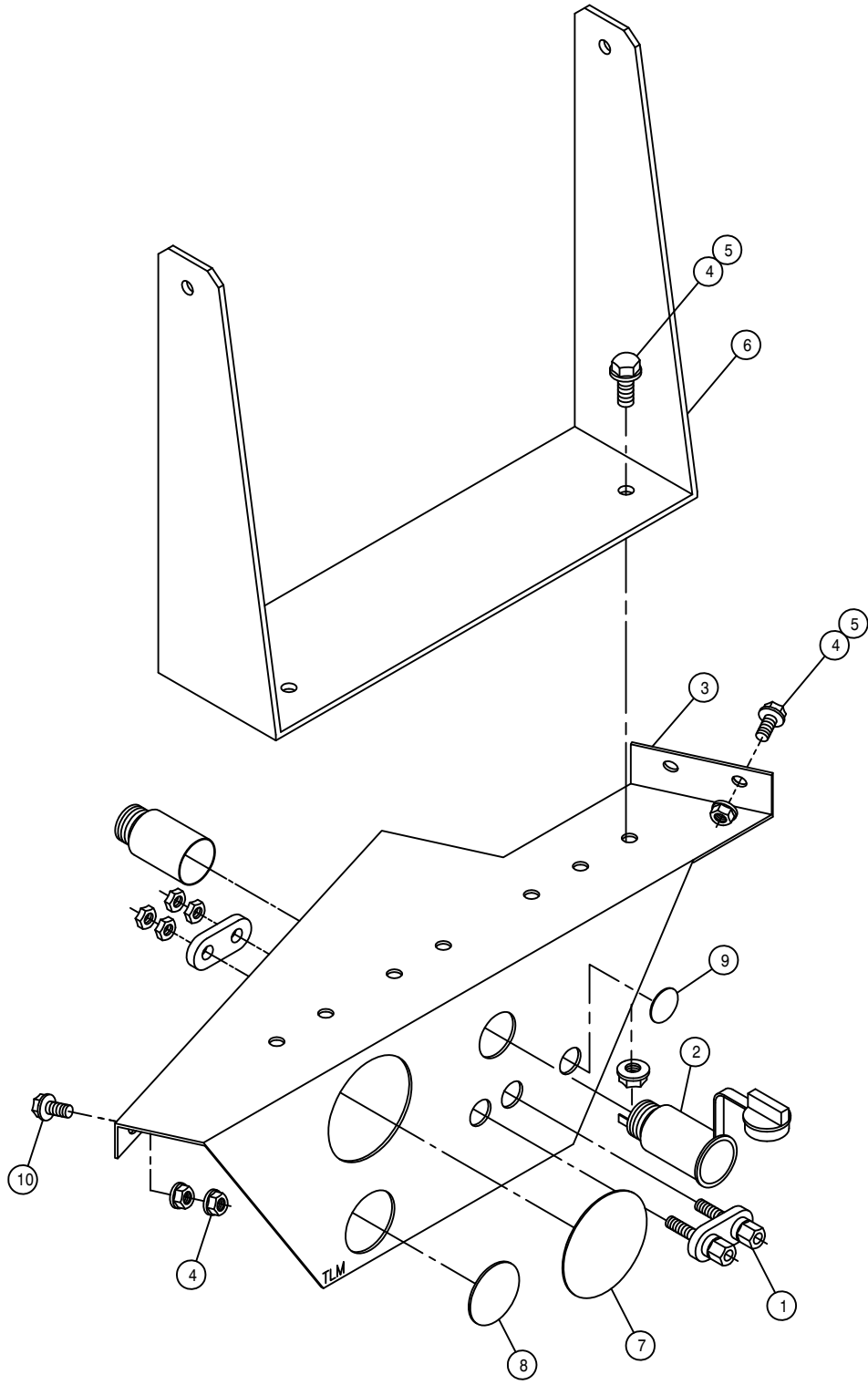

MONITOR MOUNTING BRACKET ASSEMBLY

DET.	QTY	PART NO.	DESCRIPTION
1	1	291647	DUAL BINDING POSTS
2	1	291648	POWER POINT RECEPTACLE
3	1	342215	MONITOR MT, 284 CAB 94
4	7	470121	1/4UNC HEX FLANGE LOCK NUT
5	5	470122	1/4UNC X 1/2 FLANGE HEX BOLT
6	1	690498	CONSOLE MT, RAVEN 460 95
7	1	629728	FINISH PLUG FOR 2.12 HOLE
8	1	629730	FINISH PLUG FOR 1.25 HOLE
9	1	658174	BUMPER PLUG FOR 1/2 HOLE
10	1	470118	1/4UNC X 3/4 FLANGE HEX BOLT

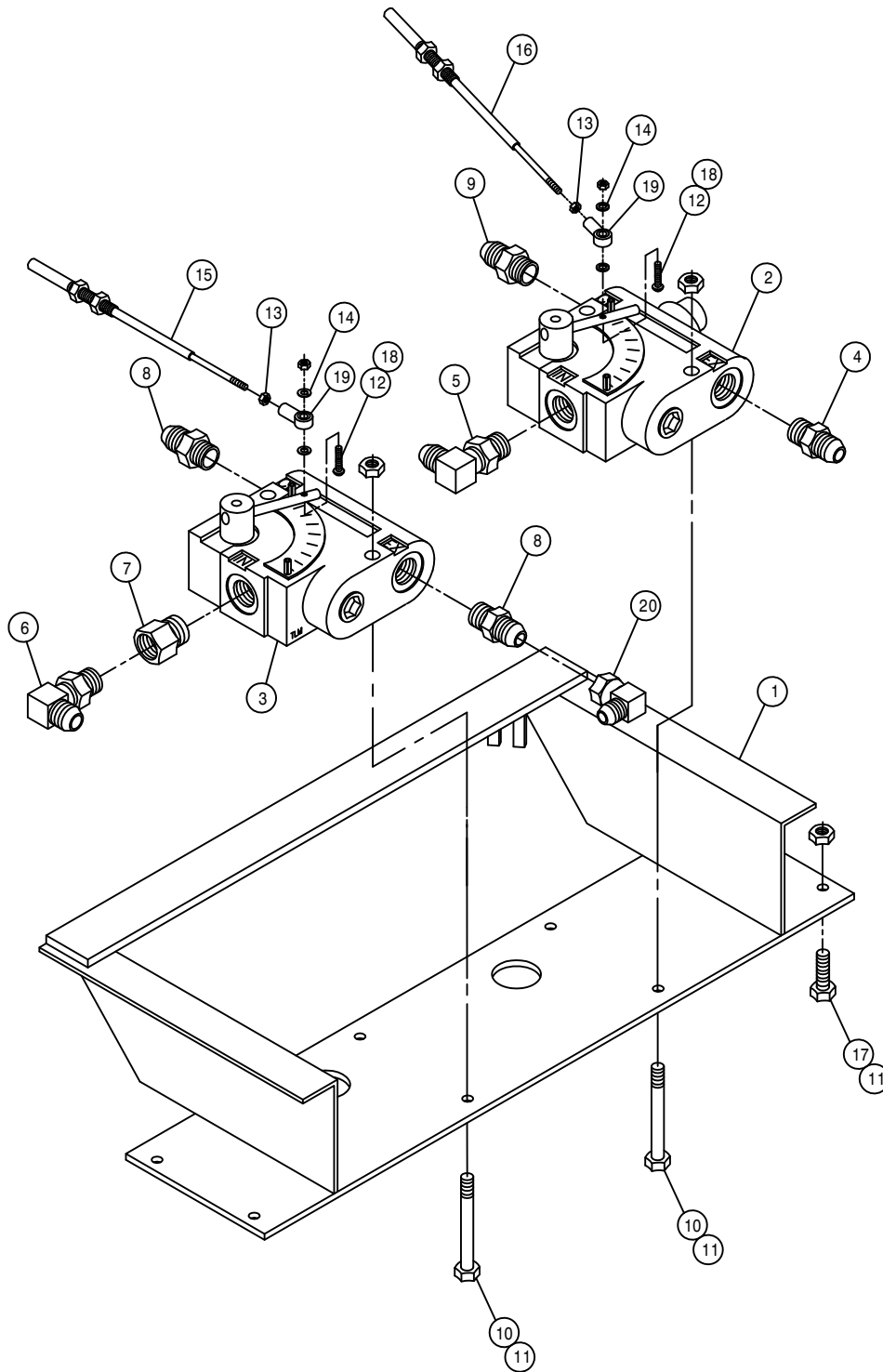

VARIABLE FLOW CONTROL ASSEMBLY

DET.	QTY	PART NO.	DESCRIPTION	
	1	342209	SOLU VFC MT WLD	94
	2	606818	FLO CONT FCR51 0-16GPM 7/8FOR	
	3	606827	FLO CONT FC51 0-3 VARI 7/8FOR	
	4	611126	7/8MJIC-7/8MOR ADPTR	
	5	611128	7/8MJIC-90-7/8MOR LBO	
	6	618119	9/16MJIC-90-9/16MOR LBO	
	7	618172	7/8MOR-9/16FOR ADPTR	
	8	618310	9/16MJIC-7/8MOR ADPTR	
	9	618327	3/4MJIC-7/8MOR ADPTR	
	10	900008	1/4UNC X 2 1/2 HEX BOLT	
	11	914000	1/4UNC HEX STOVER NUT	
	12	903893	10-32 X 1" SLT RD HD MACH SCR	
	13	910027	10-32 HEX NUT	
	14	920510	#10 LOCK WASHER	
	15	785064	CTRL CABLE 10-32 2IN X 53 LG	
	16	785063	CTRL CABLE 10-32 2IN X 42 LG	
	17	470118	1/4UNC X 3/4 FLANGE HEX BOLT	
	18	914027	10-32 HEX STOVER NUT	
	19	473921	BALL JOINT NO 10-32 THD	
	20	618618	9/16MJIC-90-9/16FJIC SWIV LBO	

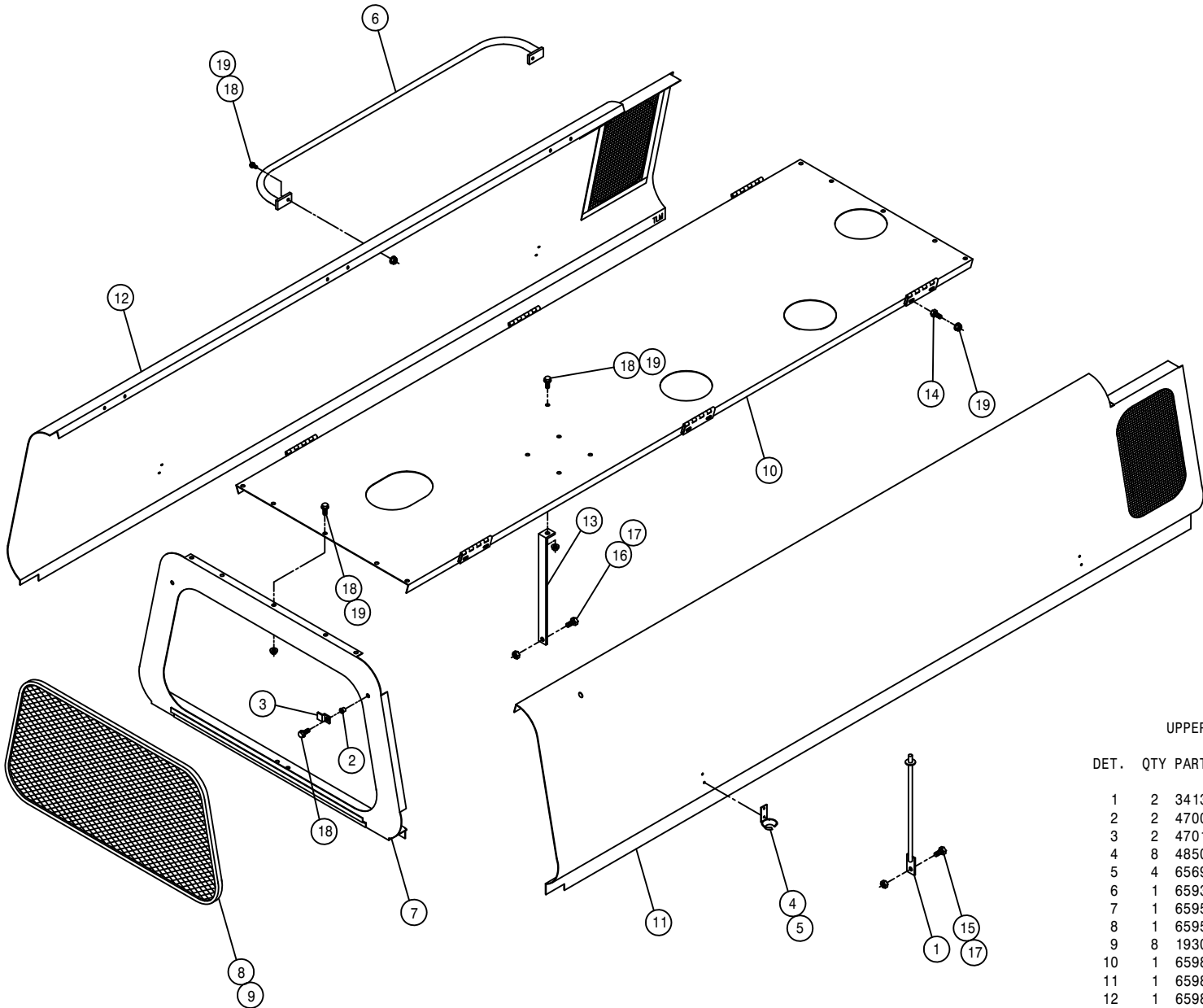

UPPER SHEET METAL ASSEMBLY

DET.	QTY	PART NO.	DESCRIPTION	
1	2	341356	ENGINE HOOD PROP WLD 8240	82
2	2	470086	1/4UNC NUTSERT .020-.100MATL	
3	2	470151	UPPER REAR PANEL SCREEN CLIP	
4	8	485053	POP RIVET 3/16 X 3/8	
5	4	656997	RUBBER HOOK BRKT 473	
6	1	659378	RH ENG HOOD HANDRAIL WLD 647S	
7	1	659575	UPPER REAR PANEL WLD 8240	82
8	1	659578	UPPER REAR PANEL SCREEN 8240	
9	8	193016	QUICKEDGE TRIM .060 TO .170	
10	1	659883	MULLION WLD CUMM 250	92
11	1	659864	RH ENGINE HOOD WLD 250	91
12	1	659865	LH ENGINE HOOD WLD 250	91
13	1	659835	MULLION SUPPORT 200	89
14	12	900000	1/4UNC X 1/2 HEX BOLT	
15	2	900128	3/8UNC X 3/4 HEX BOLT	
16	1	900129	3/8UNC X 1" HEX BOLT	
17	3	914004	3/8UNC HEX STOVER NUT	
18	15	470118	1/4UNC X 3/4 FLANGE HEX BOLT	
19	25	470121	1/4UNC HEX FLANGE LOCK NUT	

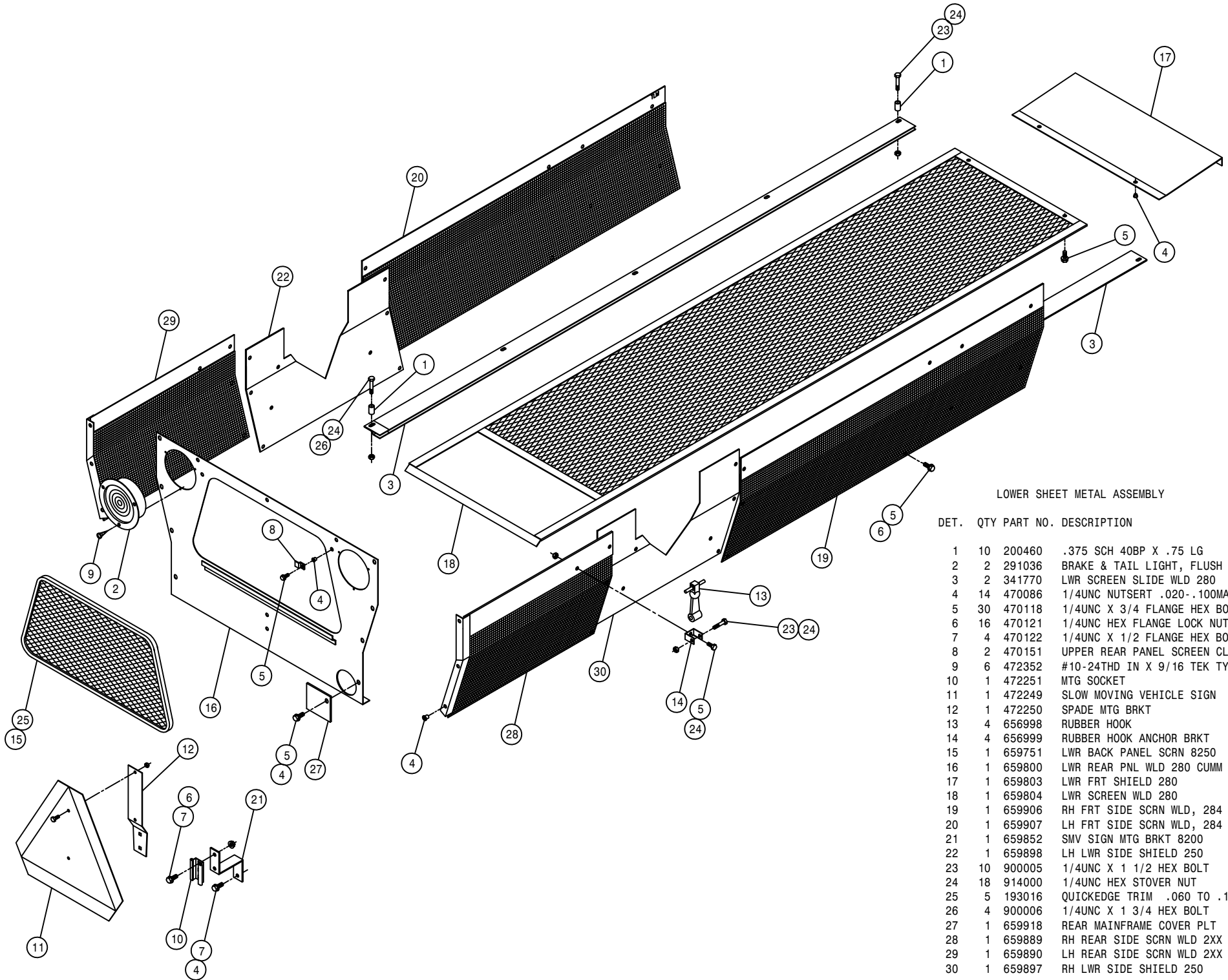

LOWER SHEET METAL ASSEMBLY

DET.	QTY	PART NO.	DESCRIPTION
1	10	200460	.375 SCH 40BP X .75 LG C/L
2	2	291036	BRAKE & TAIL LIGHT, FLUSH MT
3	2	341770	LWR SCREEN SLIDE WLD 280 89
4	14	470086	1/4UNC NUTSERT .020-.100MATL
5	30	470118	1/4UNC X 3/4 FLANGE HEX BOLT
6	16	470121	1/4UNC HEX FLANGE LOCK NUT
7	4	470122	1/4UNC X 1/2 FLANGE HEX BOLT
8	2	470151	UPPER REAR PANEL SCREEN CLIP
9	6	472352	#10-24THD IN X 9/16 TEK TYP 3
10	1	472251	MTG SOCKET
11	1	472249	SLOW MOVING VEHICLE SIG
12	1	472250	SPADE MTG BRKT
13	4	656998	RUBBER HOOK
14	4	656999	RUBBER HOOK ANCHOR BRKT
15	1	659751	LWR BACK PANEL SCR N 8250 86
16	1	659800	LWR REAR PNL WLD 280 CUMM 89
17	1	659803	LWR FRT SHIELD 280 89
18	1	659804	LWR SCREEN WLD 280 89
19	1	659906	RH FRT SIDE SCR N WLD, 284 94
20	1	659907	LH FRT SIDE SCR N WLD, 284 94
21	1	659852	SMV SIGN MTG BRKT 8200 89
22	1	659898	LH LWR SIDE SHIELD 250 92
23	10	900005	1/4UNC X 1 1/2 HEX BOLT
24	18	914000	1/4UNC HEX STOVER NUT
25	5	193016	QUICKEDGE TRIM .060 TO .170
26	4	900006	1/4UNC X 1 3/4 HEX BOLT
27	1	659918	REAR MAINFRAME COVER PLT 95
28	1	659889	RH REAR SIDE SCR N WLD 2XX 92
29	1	659890	LH REAR SIDE SCR N WLD 2XX 92
30	1	659897	RH LWR SIDE SHIELD 250 92

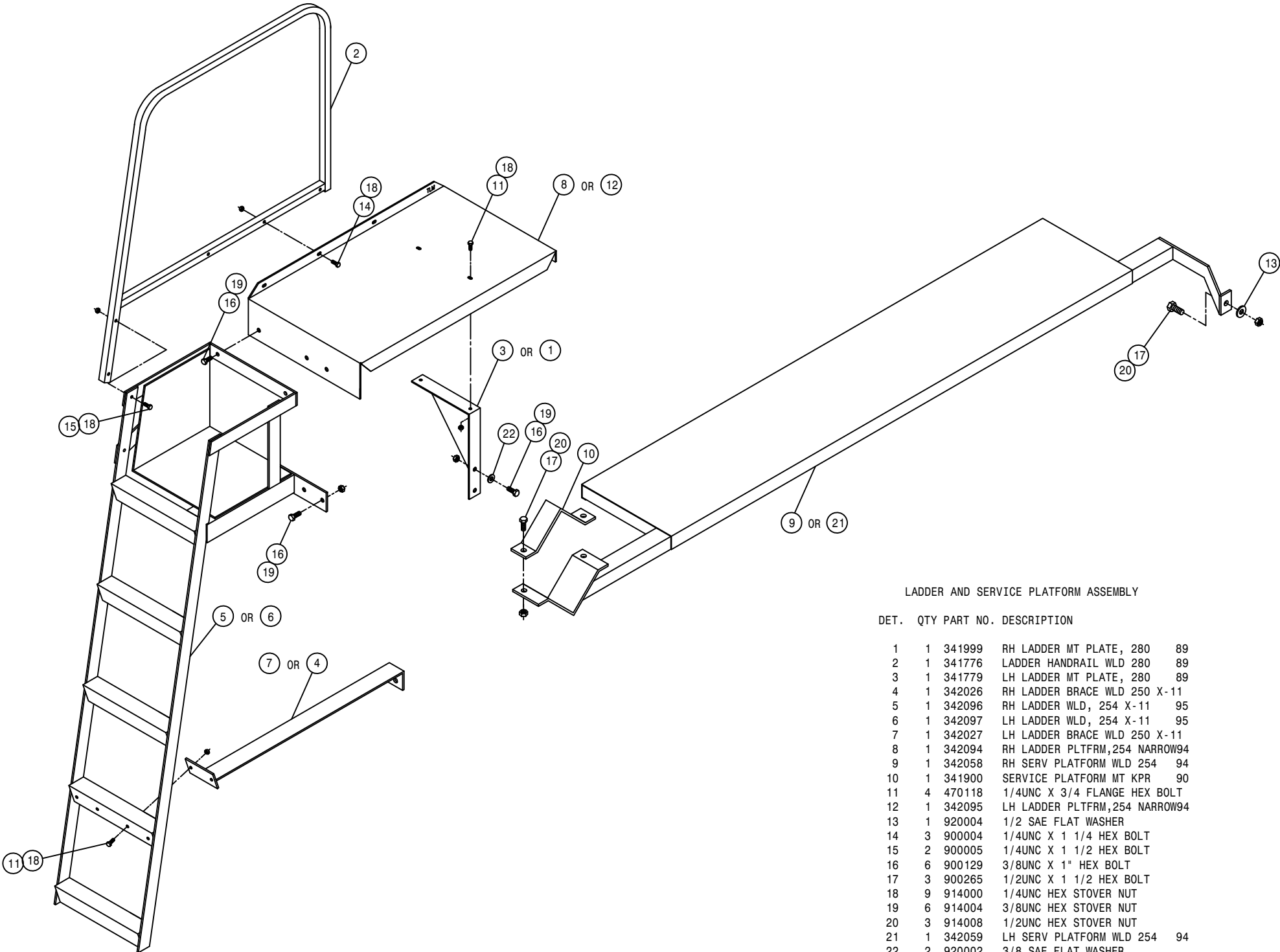

LADDER AND SERVICE PLATFORM ASSEMBLY

DET.	QTY	PART NO.	DESCRIPTION	
1	1	341999	RH LADDER MT PLATE, 280	89
2	1	341776	LADDER HANDRAIL WLD 280	89
3	1	341779	LH LADDER MT PLATE, 280	89
4	1	342026	RH LADDER BRACE WLD 250 X-11	
5	1	342096	RH LADDER WLD, 254 X-11	95
6	1	342097	LH LADDER WLD, 254 X-11	95
7	1	342027	LH LADDER BRACE WLD 250 X-11	
8	1	342094	RH LADDER PLTFRM,254 NARROW94	
9	1	342058	RH SERV PLATFORM WLD 254	94
10	1	341900	SERVICE PLATFORM MT KPR	90
11	4	470118	1/4UNC X 3/4 FLANGE HEX BOLT	
12	1	342095	LH LADDER PLTFRM,254 NARROW94	
13	1	920004	1/2 SAE FLAT WASHER	
14	3	900004	1/4UNC X 1 1/4 HEX BOLT	
15	2	900005	1/4UNC X 1 1/2 HEX BOLT	
16	6	900129	3/8UNC X 1" HEX BOLT	
17	3	900265	1/2UNC X 1 1/2 HEX BOLT	
18	9	914000	1/4UNC HEX STOVER NUT	
19	6	914004	3/8UNC HEX STOVER NUT	
20	3	914008	1/2UNC HEX STOVER NUT	
21	1	342059	LH SERV PLATFORM WLD 254	94
22	2	920002	3/8 SAE FLAT WASHER	

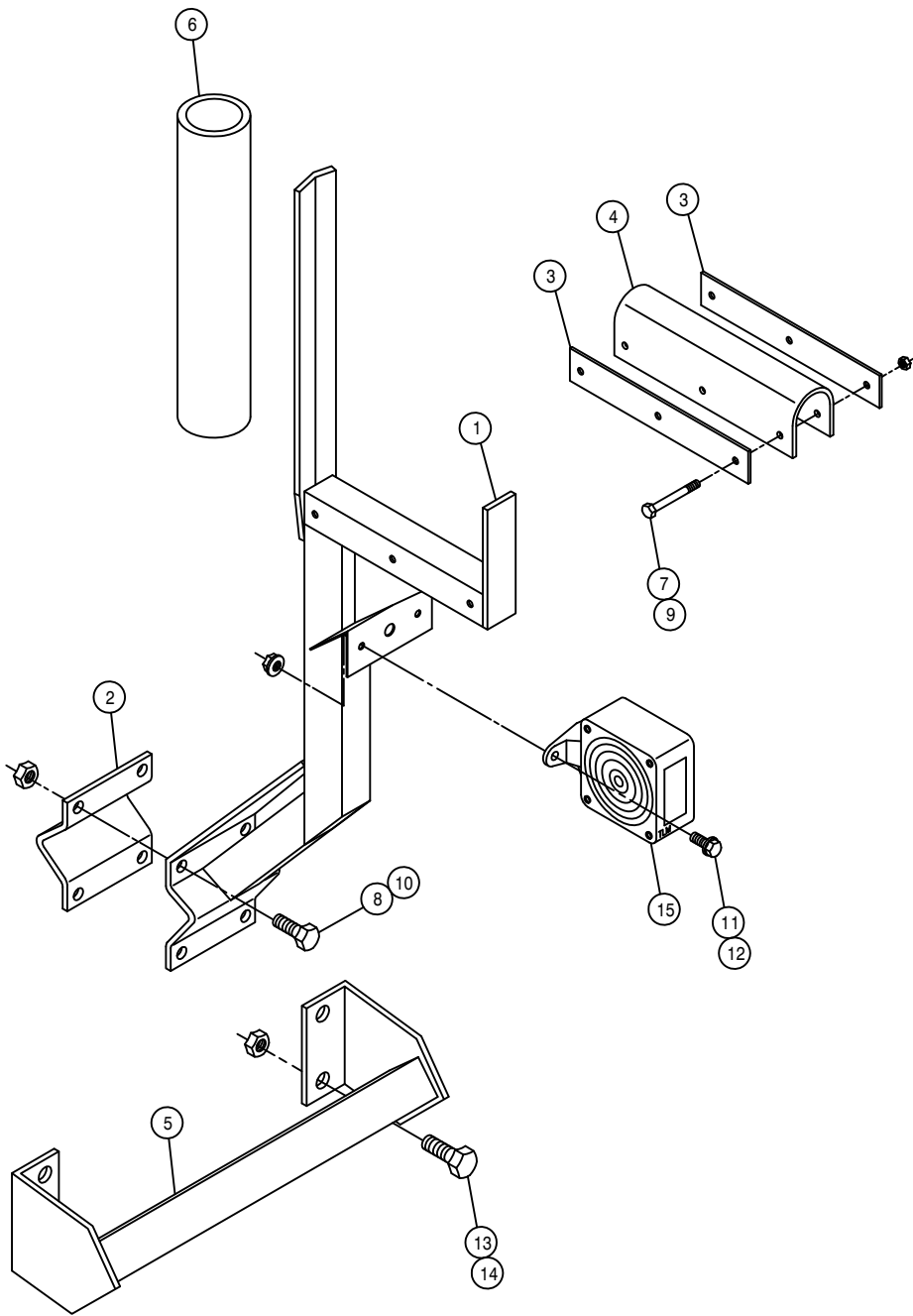

BOOM CRADLE ASSEMBLY

DET. QTY PART NO. DESCRIPTION

1	1	164245	BOOM CRADLE WLD	96
2	1	164253	BOOM CRADLE V-PLATE KEEPER	96
3	2	164254	CRADLE CUSHION KEEPER	96
4	1	164256	BOOM CRADLE CUSHION	96
5	1	164258	BOOM CRADLE MT WLD	96
6	1	601184	HOSE, 1 1/2 X 14 2BR BLK EPDM	
7	3	900008	1/4UNC X 2 1/2 HEX BOLT	
8	4	900265	1/2UNC X 1 1/2 HEX BOLT	
9	3	914000	1/4UNC HEX STOVER NUT	
10	4	914008	1/2UNC HEX STOVER NUT	
11	2	470121	1/4UNC HEX FLANGE LOCK NUT	
12	2	470118	1/4UNC X 3/4 FLANGE HEX BOLT	
13	4	900334	5/8UNC X 1 3/4 HEX BOLT	
14	4	914010	5/8UNC HEX STOVER NUT	
15	1	291604	TURN SIGNAL LIGHT,PED MT, YEL	

FRONT TANK SHIELDS

DET. QTY PART NO. DESCRIPTION

1	2	659868	FRONT TANK SHIELD 250	91
2	18	470118	1/4UNC X 3/4 FLANGED HEX BOLT	
3	18	470121	1/4UNC HEX FLANGED LOCK NUT	
4	2	659870	FRT TANK SHIELD MT 250	91
5	1	659831	LWR FRONT SHIELD 280	89
6	1	361346	MAINFRAME REAR TIE ANGLE	280
7	4	900263	1/2UNC X 1 HEX BOLT	
8	4	914008	1/2UNC HEX STOVER NUT	

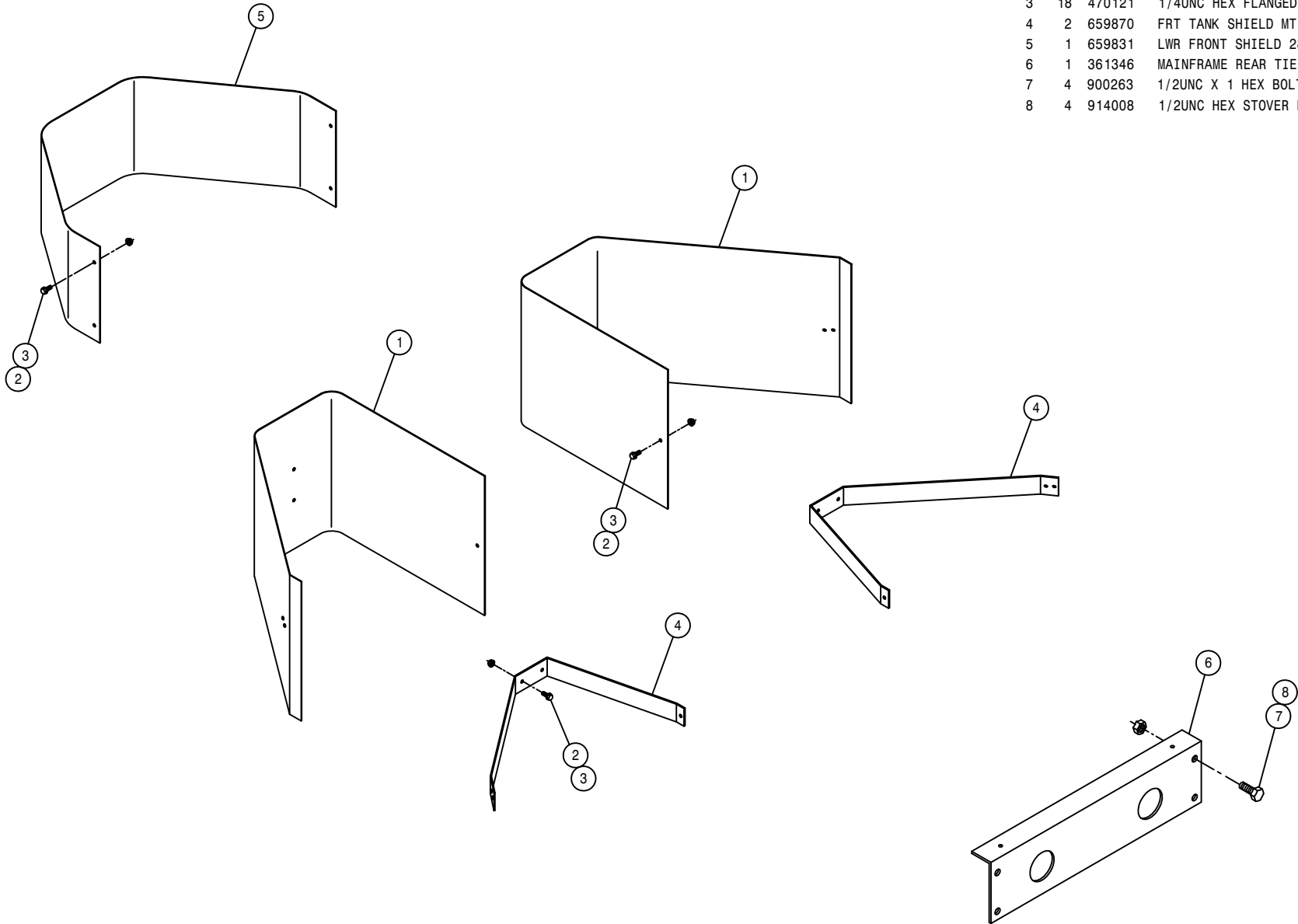

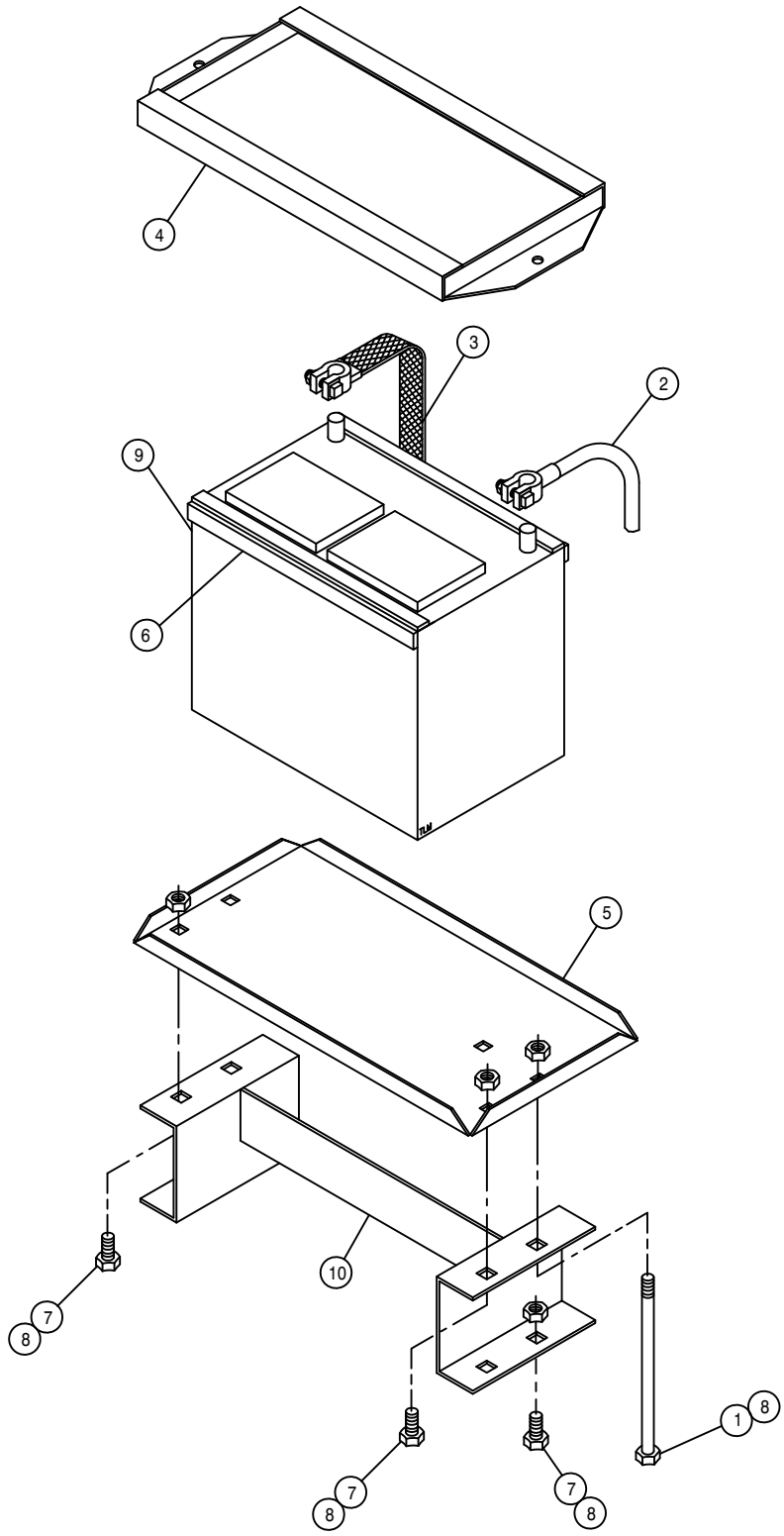

BATTERY BOX ASSEMBLY

DET.	QTY	PART NO.	DESCRIPTION
	1	2	901150 3/8UNC X 9" CARR BOLT
	1	291128	BATTERY CABLE 48 IN
	1	290111	GROUND STRAP
	1	341322	BATTERY HOLD DOWN WLD 1981
	2	361149	BATTERY BOX 8300-8400 1981
	4	193022	STICKERTITE 1/4 X 3/4
	6	900128	3/8UNC X 3/4 HEX BOLT
	8	914004	3/8UNC HEX STOVER NUT
	1	291122	BATTERY, 12V 950CCA, SAE POST
	1	361417	BATT BOX SPACER WLD 94

LIFTARM ASSEMBLY

DET. QTY PART NO. DESCRIPTION

DET.	QTY	PART NO.	DESCRIPTION
1	2	160471	LWR LIFT ARM WLD 8540-8250 87
2	1	160495	RH LIFT ARM MT WLD 280 89
3	1	160496	LH LIFT ARM MT WLD 280 89
4	12	160691	BUSH LIFT ARM LONG 470
5	9	470287	TUBE CLAMP, .375-.375 (PAIR)
6	1	164085	UPPER LIFT ARM WLD,254 X11 95
7	12	471005	1/4 28 X 1/2 GREASE ZERK
8	9	914000	1/4UNC HEX STOVER NUT
9	2	620700	LIFT CYL ASSY,2.50 W/FTGS 99
10	9	900004	1/4UNC X 1 1/4 HEX BOLT
11	6	900333	5/8UNC X 1 1/2 HEX BOLT
12	4	900342	5/8UNC X 4" HEX BOLT
13	8	900343	5/8UNC X 4 1/2 HEX BOLT
14	18	914010	5/8UNC HEX STOVER NUT
15	1	615643	LIFT HYD TUBE ASSY,UP 254X11
16	1	615644	LIFT HYD TUBE ASSY,DN 254X11
17	1	615645	LEVEL HYD TUBE ASSY,UP 254X11
18	1	615646	LEVEL HYD TUBE ASSY,DN 254X11
19	1	615647	FOLD HYD TUBE ASSY,IN 254X11
20	1	615648	FOLD HYD TUBE ASSY,OUT 254X11

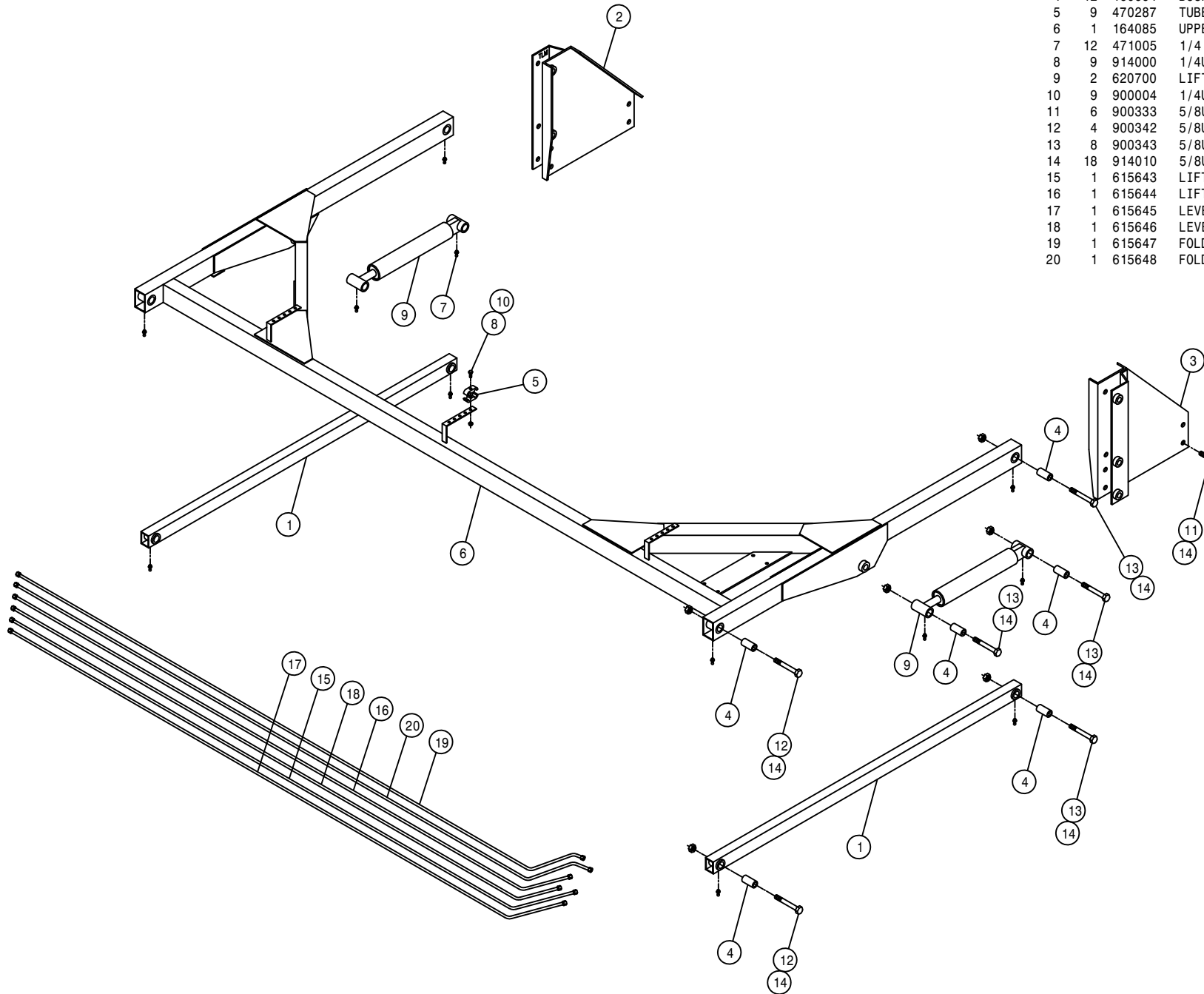

TRANSOM ASSEMBLY

DET. QTY PART NO. DESCRIPTION

DET.	QTY	PART NO.	DESCRIPTION
1	2	160429	FEEDER HOSE SUPPORT SPRING MT
2	4	160691	BUSH LIFT ARM LONG 470
3	2	164124	NOZL MT TUBE,254X-11, 284W 96
4	4	164125	NOZL MT TUBE HANGER CHAN 96
5	4	164127	NOZL MT TUBE CLAMP 96
6	2	164128	LEVEL CYL PIVOT BRKT WLD 96
7	1	164131	RH BOOM BREAKAWAY WLD 96
8	1	164132	LH BOOM BREAKAWAY WLD 96
9	4	470136	3/8UNC-3 1/16ID-3 SQ U-BOLT
10	2	164264	5/8UNC X 3" EYE BOLT
11	6	471005	1/4 28 X 1/2 GREASE ZERK
12	16	900007	1/4UNC X 2" HEX BOLT
13	2	900846	5/8UNC X 4 1/4 HEX BOLT GR8
14	2	910010	5/8UNC HEX NUT
15	16	914000	1/4UNC HEX STOVER NUT
16	8	914004	3/8UNC HEX STOVER NUT
17	4	914008	1/2UNC HEX STOVER NUT
18	8	914010	5/8UNC HEX STOVER NUT
19	8	920005	5/8 SAE FLAT WASHER
20	2	900848	5/8UNC X 4 3/4 HEX BOLT GR8
21	2	164230	BOOM PIVOT PIN,.75 X 13.31 96
22	4	470162	COTTER PIN 3/16 X 1 1/2 SQCUT
23	2	482000	SPRING,.930D X 8.5LG,.072WIRE
24	2	520126	CUSH HOSE CLAMP 2IN X 5/8W
25	2	620584	LEVEL CYL ASSY W/FTGS 96
26	2	620594	FOLD CYL ASSY W/FTGS 96
27	2	900268	1/2UNC X 2 1/2 HEX BOLT
28	2	900845	1/2UNC X 3 3/4 HEX BOLT GR8
29	2	900844	5/8UNC X 2 3/4 HEX BOLT GR8
30	4	920006	3/4 SAE FLAT WASHER
31	1	164114	TRANSOM WLD, 254 X-11 96
32	2	471023	GREASE ZERK 1/4-28 X 45
33	2	620630	ACCUMULATOR ASSY,60' BOOM 96
34	4	520099	HOSE CLAMP NO 40 STAINLESS

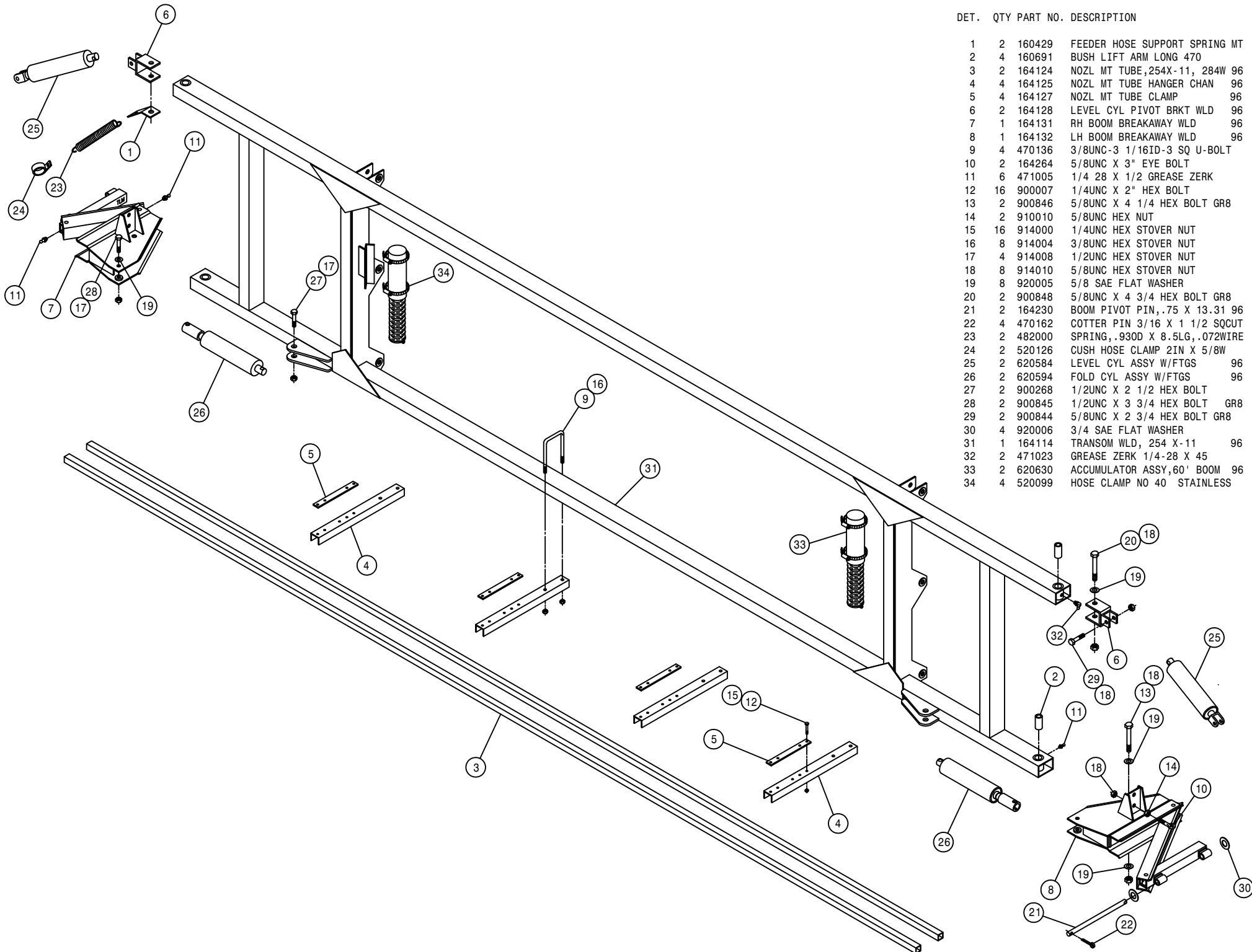

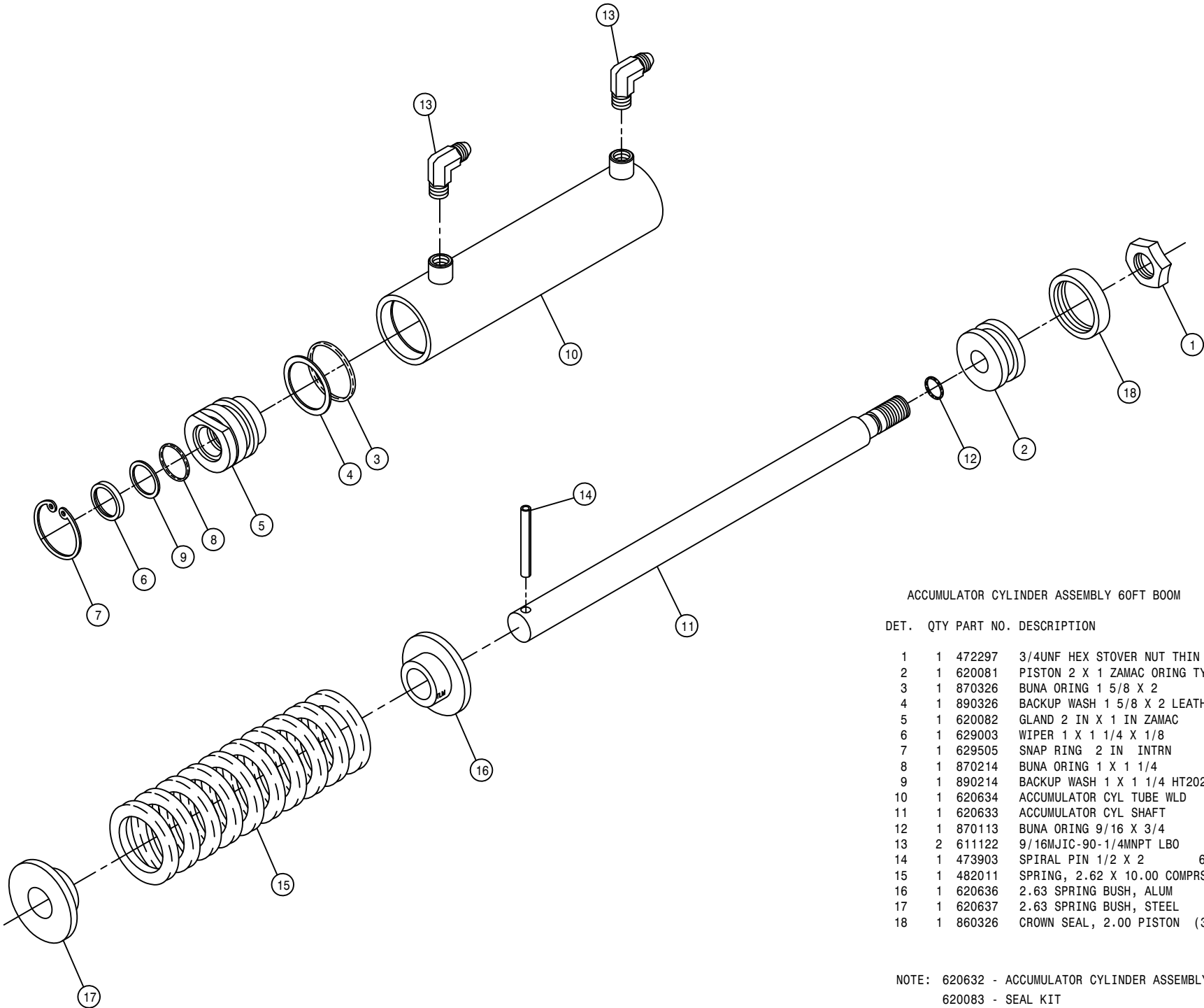

ACCUMULATOR CYLINDER ASSEMBLY 60FT BOOM

DET.	QTY	PART NO.	DESCRIPTION
	1	472297	3/4UNF HEX STOVER NUT THIN
	1	620081	PISTON 2 X 1 ZAMAC ORING TYPE
	1	870326	BUNA ORING 1 5/8 X 2
	1	890326	BACKUP WASH 1 5/8 X 2 LEATH
	1	620082	GLAND 2 IN X 1 IN ZAMAC
	1	629003	WIPER 1 X 1 1/4 X 1/8
	1	629505	SNAP RING 2 IN INTRN
	1	870214	BUNA ORING 1 X 1 1/4
	1	890214	BACKUP WASH 1 X 1 1/4 HT2022
	1	620634	ACCUMULATOR CYL TUBE WLD 96
	1	620633	ACCUMULATOR CYL SHAFT 96
	1	870113	BUNA ORING 9/16 X 3/4
	2	611122	9/16MJC-90-1/4MNPT LBO
	1	473903	SPIRAL PIN 1/2 X 2 640
	1	482011	SPRING, 2.62 X 10.00 COMPRSN
	1	620636	2.63 SPRING BUSH, ALUM 96
	1	620637	2.63 SPRING BUSH, STEEL 96
	1	860326	CROWN SEAL, 2.00 PISTON (326)

NOTE: 620632 - ACCUMULATOR CYLINDER ASSEMBLY 1-12
 620083 - SEAL KIT

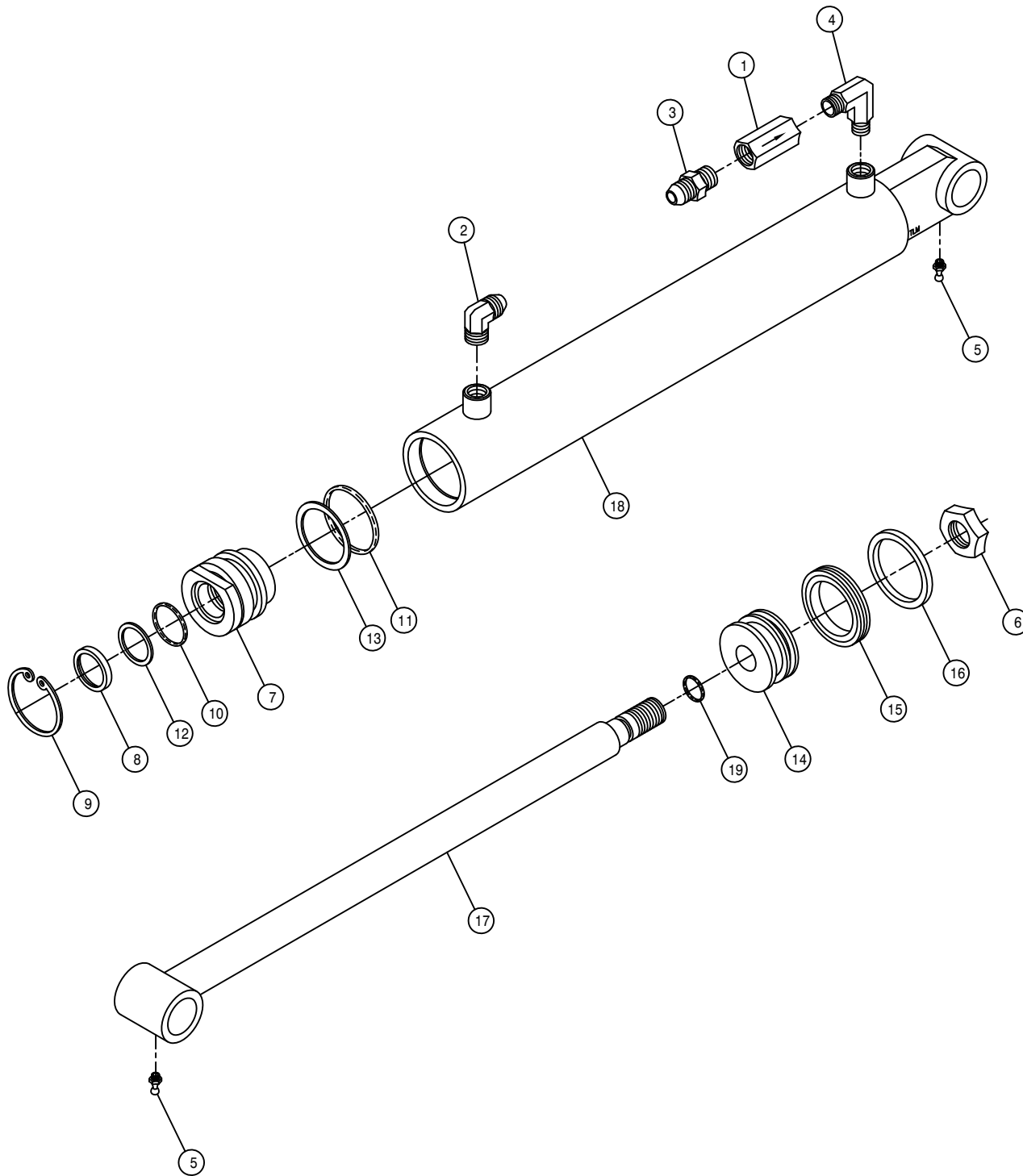

LIFT CYLINDER ASSEMBLY

DET.	QTY	PART NO.	DESCRIPTION
	1	610675	RESTRICTOR, .042 1-WAY, 1/2FNPT
	2	611122	9/16MJIC-90-1/4MNPT LBO
	3	618018	9/16MJIC-1/2MNPT ADPTR
	4	618633	1/2MNPT-90-1/4MNPT REDU LBO
	5	471005	1/4 28 X 1/2 GREASE ZERK
	6	472297	3/4UNF HEX STOVER NUT THIN
	7	620675	GLAND, 2.50OD X 1.25ID, ALUM
	8	629002	WIPER 1 1/4 X 1 1/2 X 1/8
	9	629504	SNAP RING 2 1/2 IN INTRN
	10	870218	BUNA ORING 1 1/4 X 1 1/2
	11	870330	NEO ORING 2 1/8 X 2 1/2
	12	890218	BACKUP WASH1 1/4X1 1/2 HT2022
	13	890330	BACKUP WASH 2 1/8 X 2 1/2
	14	620703	PISTON, 2.50" T-SEAL/WEAR RING
	15	860330	T-SEAL, 2.50 OD W/BACKUPS(330)
	16	860331	WEAR RING, .25 X 2.50
	17	620704	LIFT CYL SHAFT WLD 99
	18	620706	LIFT CYL TUBE WLD, 2.50" 99
	19	870113	BUNA ORING 9/16 X 3/4

NOTE: 1. 620701 - LIFT CYLINDER ASSEMBLY
 2. 620700 - LIFT CYLINDER ASSEMBLY WITH FITTINGS
 3. 620708 - SEAL KIT

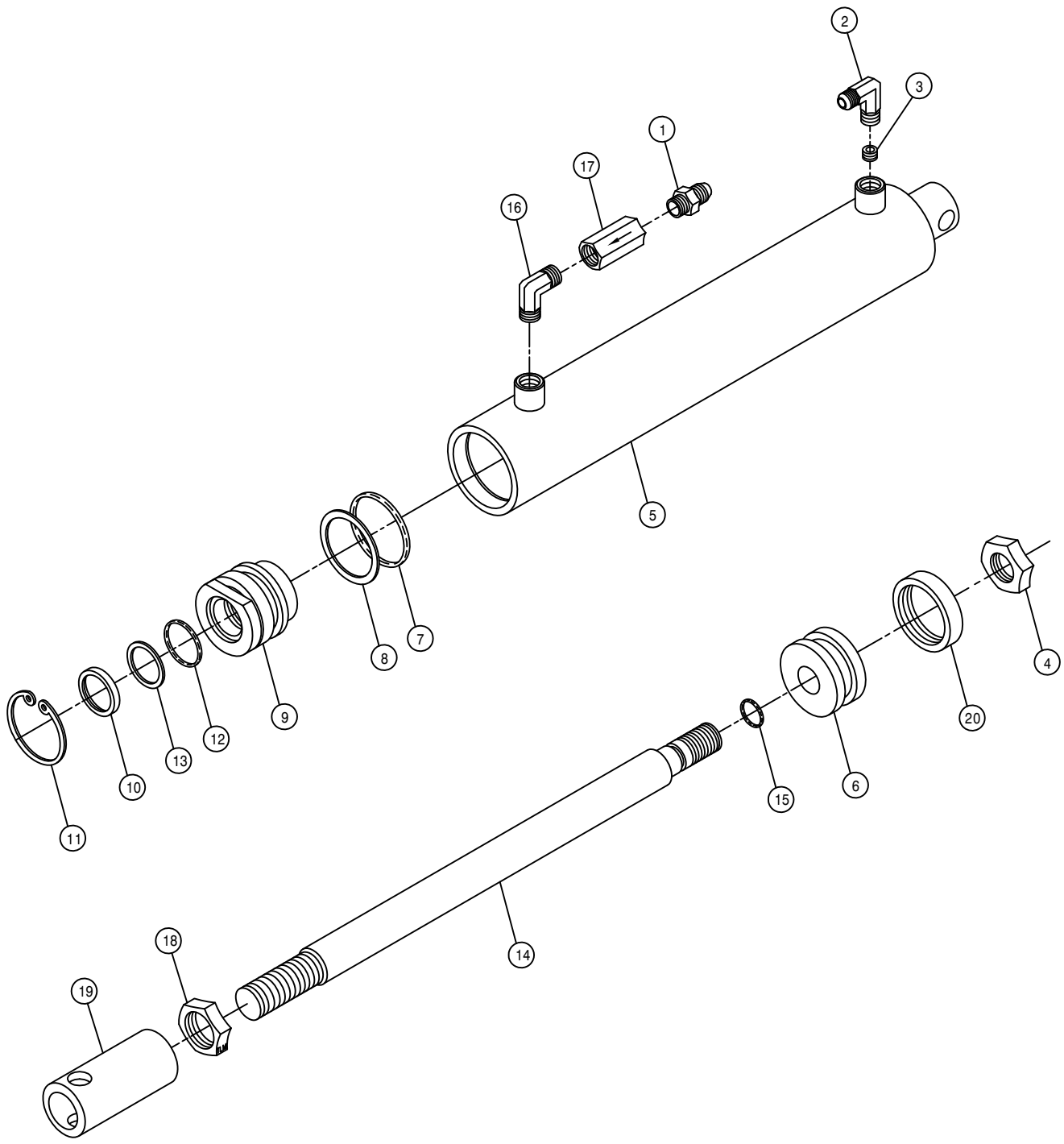

FOLD CYLINDER ASSEMBLY

DET.	QTY	PART NO.	DESCRIPTION
1	1	618018	9/16MJIC-1/2MNPT ADPTR
2	1	440338	9/16 JIC W/90X1/4 NPT TAPPED
3	1	614366	RESTRICTOR SCREW, .042 DIA
4	1	472297	3/4UNF HEX STOVER NUT THIN
5	1	620053	TUBE WLD, 2IN FOLD & LEVEL
6	1	620081	PISTON 2 X 1 ZAMAC ORING TYPE
7	1	870326	BUNA ORING 1 5/8 X 2
8	1	890326	BACKUP WASH 1 5/8 X 2 LEATH
9	1	620082	GLAND 2 IN X 1 IN ZAMAC
10	1	629003	WIPER 1 X 1 1/4 X 1/8
11	1	629505	SNAP RING 2 IN INTRN
12	1	870214	BUNA ORING 1 X 1 1/4
13	1	890214	BACKUP WASH 1 X 1 1/4 HT2022
14	1	620596	FOLD CYL SHAFT 96
15	1	870113	BUNA ORING 9/16 X 3/4
16	1	618633	1/2MNPT-90-1/4MNPT REDU LBO
17	1	610450	RESTRICTOR .025 1-WAY, 1/2FNPT
18	1	472322	7/8UNF HEX JAM NUT
19	1	620597	FOLD CYL ADJ SLEEVE 96
20	1	860326	CROWN SEAL, 2" PISTON, HYD

NOTE: 1. 620595 - FOLD CLINDER ASSEMBLY
 2. 620594 - FOLD CYLINDER ASSEMBLY WITH FITTINGS
 3. 614365 - RESTRICTOR ELBOW ASSEMBLY
 4. 620083 - SEAL KIT

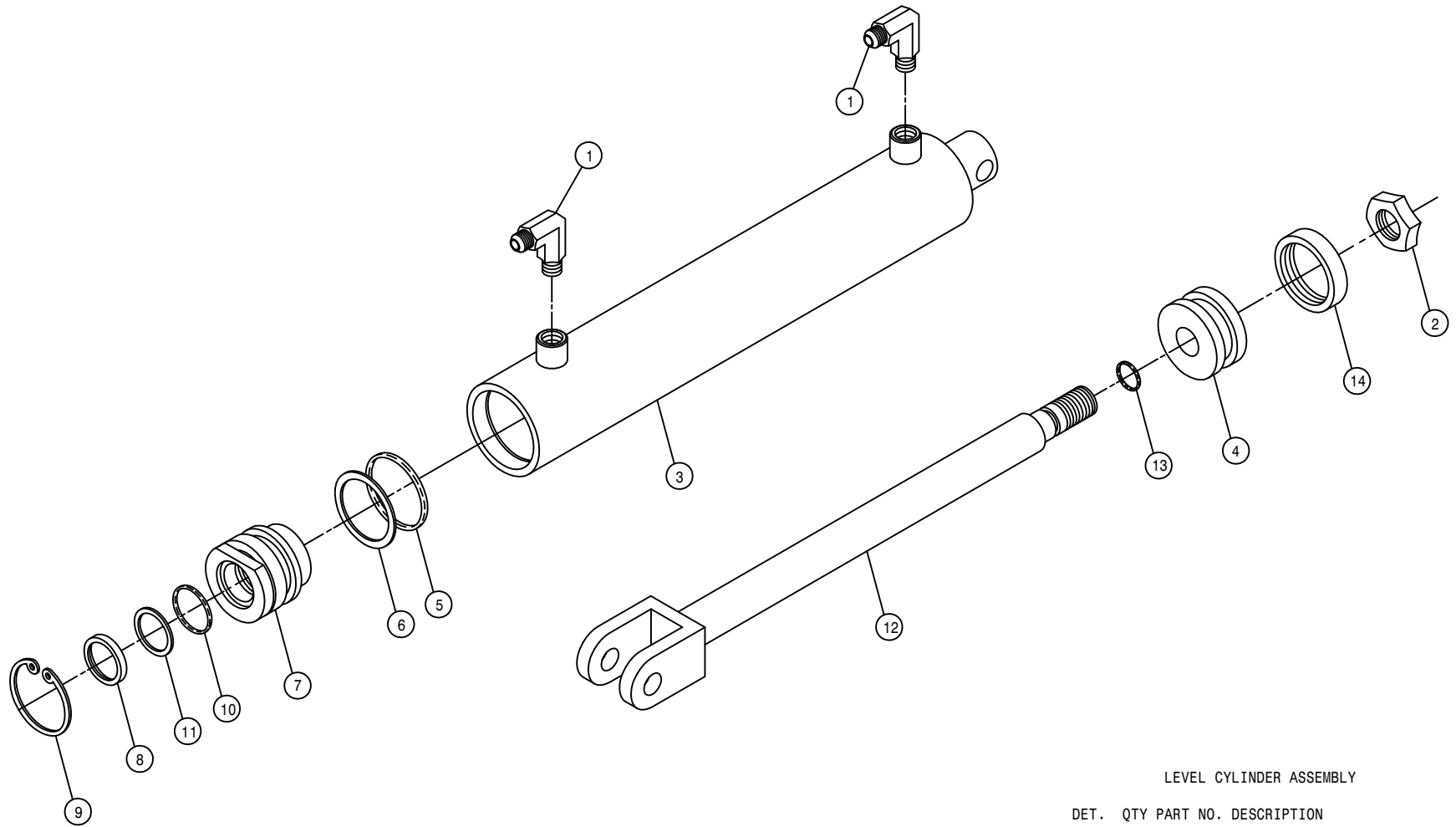

LEVEL CYLINDER ASSEMBLY

DET.	QTY	PART NO.	DESCRIPTION
1	2	611122	9/16MJIC-90-1/4MNPT LBO
2	1	472297	3/4UNF HEX STOVER NUT THIN
3	1	620586	LEVEL CYL TUBE WLD 96
4	1	620081	PISTON 2 X 1 ZAMAC ORING TYPE
5	1	870326	BUNA ORING 1 5/8 X 2
6	1	890326	BACKUP WASH 1 5/8 X 2 LEATH
7	1	620082	GLAND 2 IN X 1 IN ZAMAC
8	1	629003	WIPER 1 X 1 1/4 X 1/8
9	1	629505	SNAP RING 2 IN INTRN
10	1	870214	BUNA ORING 1 X 1 1/4
11	1	890214	BACKUP WASH 1 X 1 1/4 HT2022
12	1	620591	LEVEL CYL SHAFT WLD 96
13	1	870113	BUNA ORING 9/16 X 3/4
14	1	860326	CROWN SEAL, 2" PISTON, HYD

NOTE: 1. 620585 - LEVEL CLINDER ASSEMBLY
 2. 620584 - LEVEL CYLINDER ASSEMBLY W/FTGS
 3. 620083 - SEAL KIT

60 FOOT BOOM HINGE PIVOT ASSEMBLY

DET.	QTY	PART NO.	DESCRIPTION
1	1	164205	BOOM WLD, 60' OUTER SECT 96
2	1	164231	BOOM PIN, 1.00 X 11.75 96
3	2	470162	COTTER PIN 3/16 X 1 1/2 SQCUT
4	1	472276	CLEVIS PIN, 1.00 X 2.00 PLT
5	1	611016	HAIR PIN #6
6	2	900128	3/8UNC X 3/4 HEX BOLT
7	2	914004	3/8UNC HEX STOVER NUT
8	2	438302	HOSE SUPPORT RING WLD W/WASHER
9	1	471005	1/4 28 X 1/2 GREASE ZERK
10	1	471028	GREASE ZERK, 1/4-28 90DEG

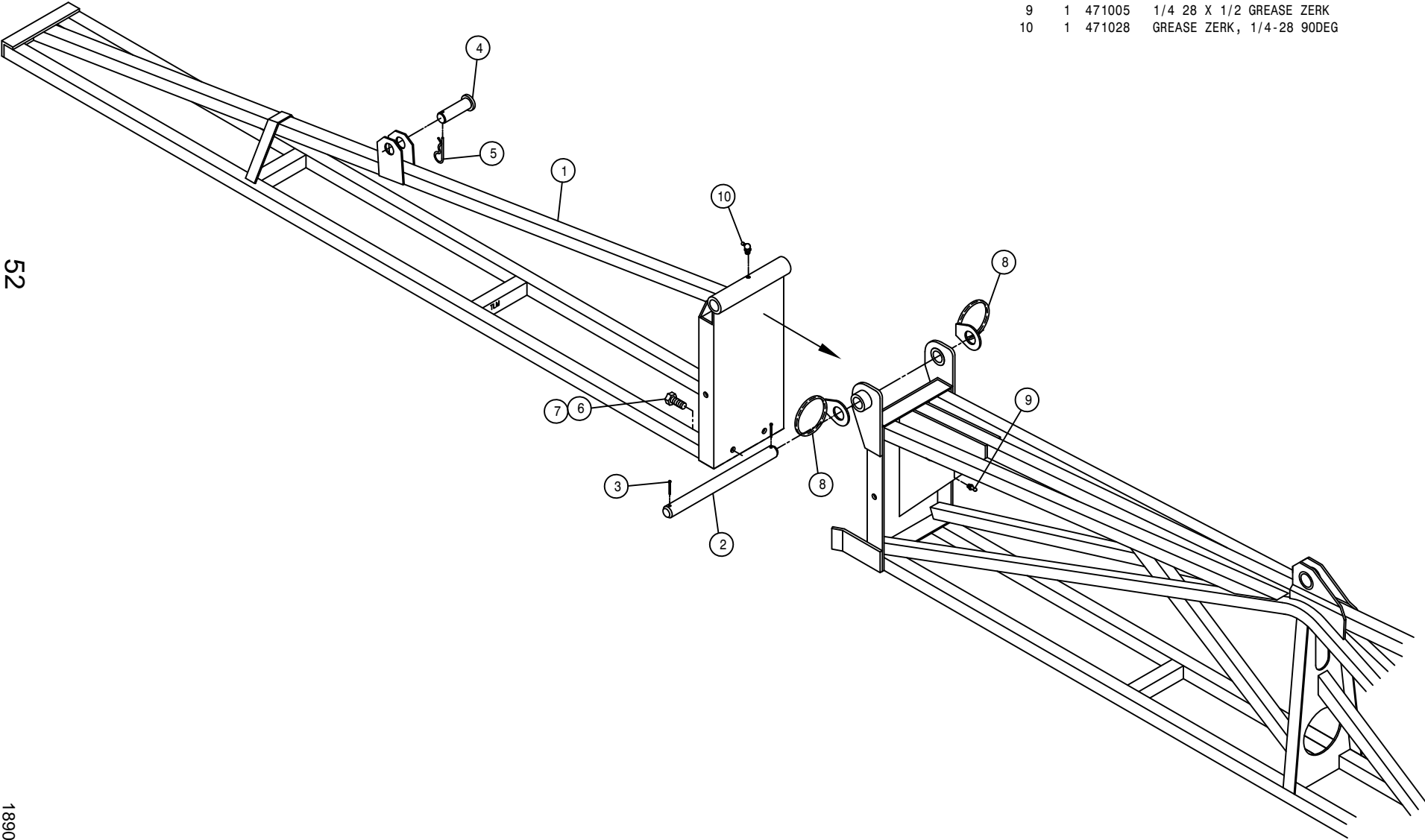

52

INNER BOOM ASSEMBLY

DET. QTY PART NO. DESCRIPTION

DET.	QTY	PART NO.	DESCRIPTION	
1	1	164150	BOOM WLD, INNER SECTION	96
2	1	164227	BOOM BALL JOINT BUSH	96
3	1	164263	SWIVEL, 5/8 BOOM EYEBOLT	
4	1	164265	5/8UNC X 7 1/2 EYEBOLT	
5	1	482014	SPRING, 3.25 X 11.50 EXTENSION	
6	2	910010	5/8UNC HEX NUT	
7	1	471028	GREASE ZERK, 1/4-28 90DEG	
8	1	900844	5/8UNC X 2 3/4 HEX BOLT GR8	
9	1	914010	5/8UNC HEX STOVER NUT	
10	2	164275	NOZL MT WLD	96
11	2	900007	1/4UNC X 2" HEX BOLT	
12	2	914000	1/4UNC HEX STOVER NUT	

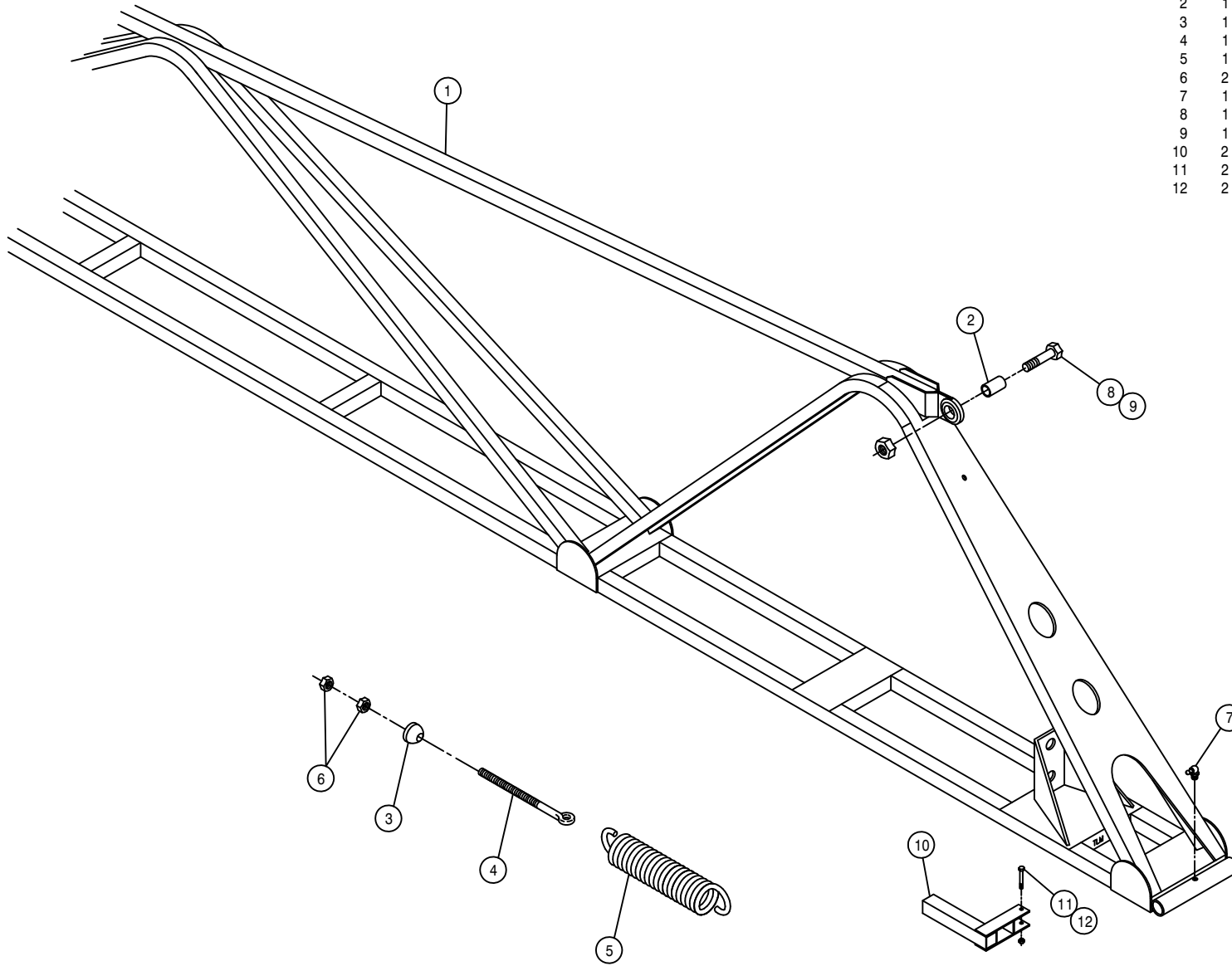

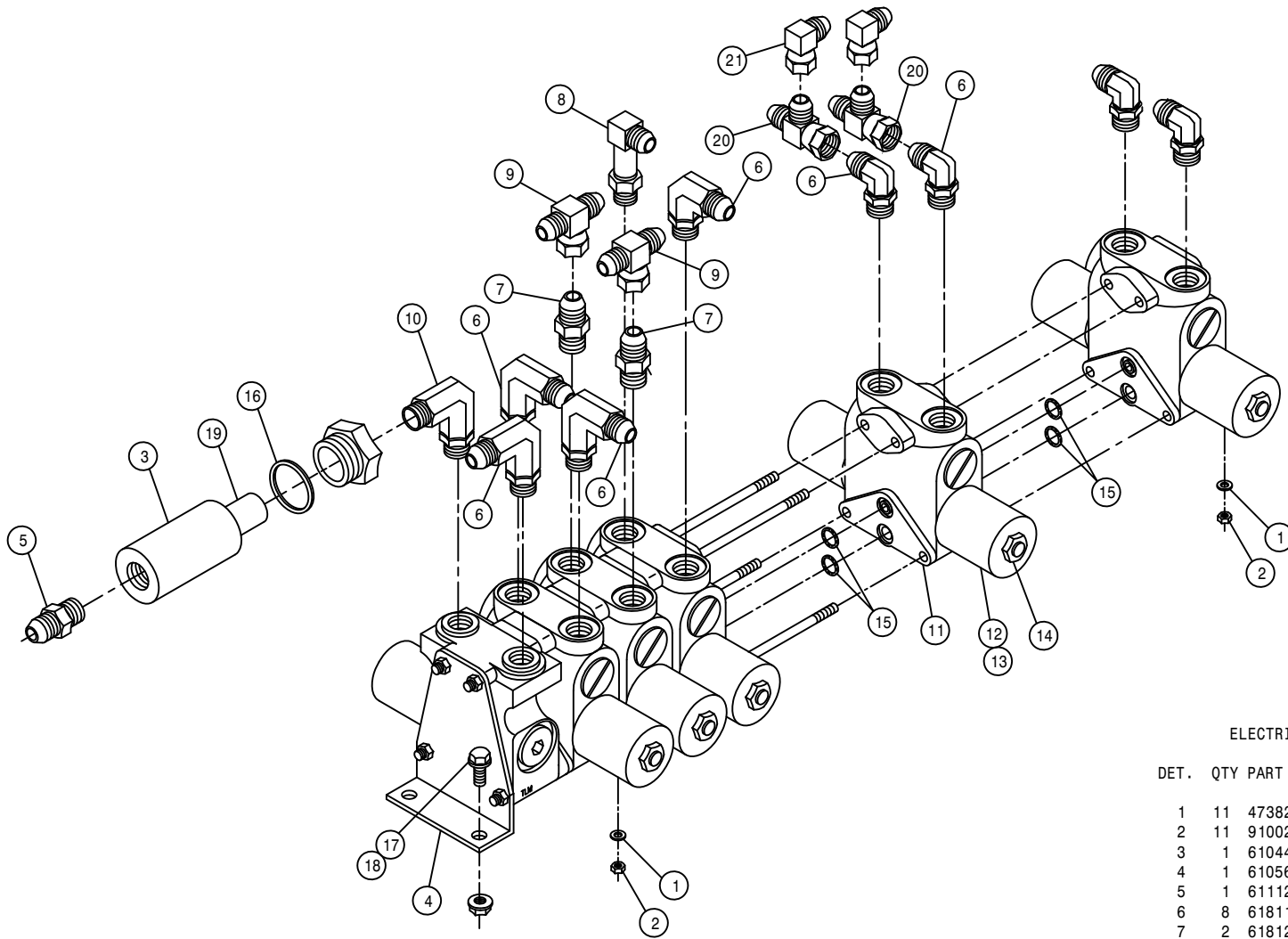

ELECTRIC BOOM VALVE ASSEMBLY

DET.	QTY	PART NO.	DESCRIPTION
	11	473821	#10 INT TOOTH WASHER
	11	910027	10-32 HEX NUT
	1	610447	HYD FILTER, INLINE 1/4FNPT 90M
	1	610569	6 SECT, 5 FUNCTN HYD VLV, EATON
	1	611121	9/16MJIC-1/4MNPT ADPTR
	8	618119	9/16MJIC-90-9/16MOR LBO
	2	618126	9/16MJIC-9/16MOR ADPTR
	1	618440	9/16MJIC-90-9/16MOR EX LG LBO
	2	618514	9/16FJ SW BRANCH TEE-9/16MJ
	1	618562	9/16MOR-90-1/4MNPT LBO
	1	610574	VALVE SECTION ASSY FOR 610569
	1	610575	SOLENOID COIL ASSY FOR 610569
	1	610576	SOLENOID CASE FOR 610569
	1	610577	SOLENOID CASE NUT FOR 610569
	4	610578	SECTION O-RING FOR 610569
	1	610462	GASKET FOR 610447 ARROW FILT
	4	470118	1/4UNC X 3/4 FLANGE HEX BOLT
	4	470121	1/4UNC HEX FLANGE LOCK NUT
	1	610459	90M FILTER & GASKET FOR 610447
	2	618486	9/16FJIC SW RUN TEE-9/16MJIC
	2	618618	9/16MJIC-90-9/16FJIC SWIV LBO

AGITATOR ASSEMBLY

DET. QTY PART NO. DESCRIPTION

DET.	QTY	PART NO.	DESCRIPTION
1	2	470199	1/4UNC X 3/8 SQHD CUP SET SCR
2	7	470089	1/4UNC HEX LOC NUT NYL INS SS
3	3	470092	1/4UNC-3/4ID-1 1/4 U-BOLT SS
4	1	610510	CESSNA GEAR MOTOR 1.48CI
5	1	611121	9/16MJIC-1/4MNPT ADPTR
6	2	618092	1 1/16MOR-1/2FNPT ADPTR
7	2	618107	9/16MJIC-90-1/2MNPT LBO
8	1	706403	FRT AGIT SHFT BRG, NYLON
9	1	706401	REAR AGIT SHFT BRG, NYLON
10	1	706402	AGIT SHFT GLAND NUT, NYLON
11	3	763027	AGIT IMPELLER
12	1	763393	AGIT SHAFT 250 91
13	1	763217	GLAND PACKING, 13 IN. LONG
14	1	763357	AGIT MTR MT PLT CES 280 91
15	1	763359	AGIT MTR CPLR 280 91
16	2	900064	5/16UNC X 3/4 HEX BOLT
17	2	900130	3/8UNC X 1 1/4 HEX BOLT
18	2	914002	5/16UNC HEX STOVER NUT
19	2	914004	3/8UNC HEX STOVER NUT
20	2	920001	5/16 SAE FLAT WASHER
21	2	920002	3/8 SAE FLAT WASHER
22	1	470200	1/4UNC X 1 3/4 HEX BOLT SS
23	1	763358	AGIT MTR MT YOKE CES 280 91
24	1	763361	AGIT CPLR SHIELD 280 91
25	1	900000	1/4UNC X 1/2 HEX BOLT
26	1	914000	1/4UNC HEX STOVER NUT

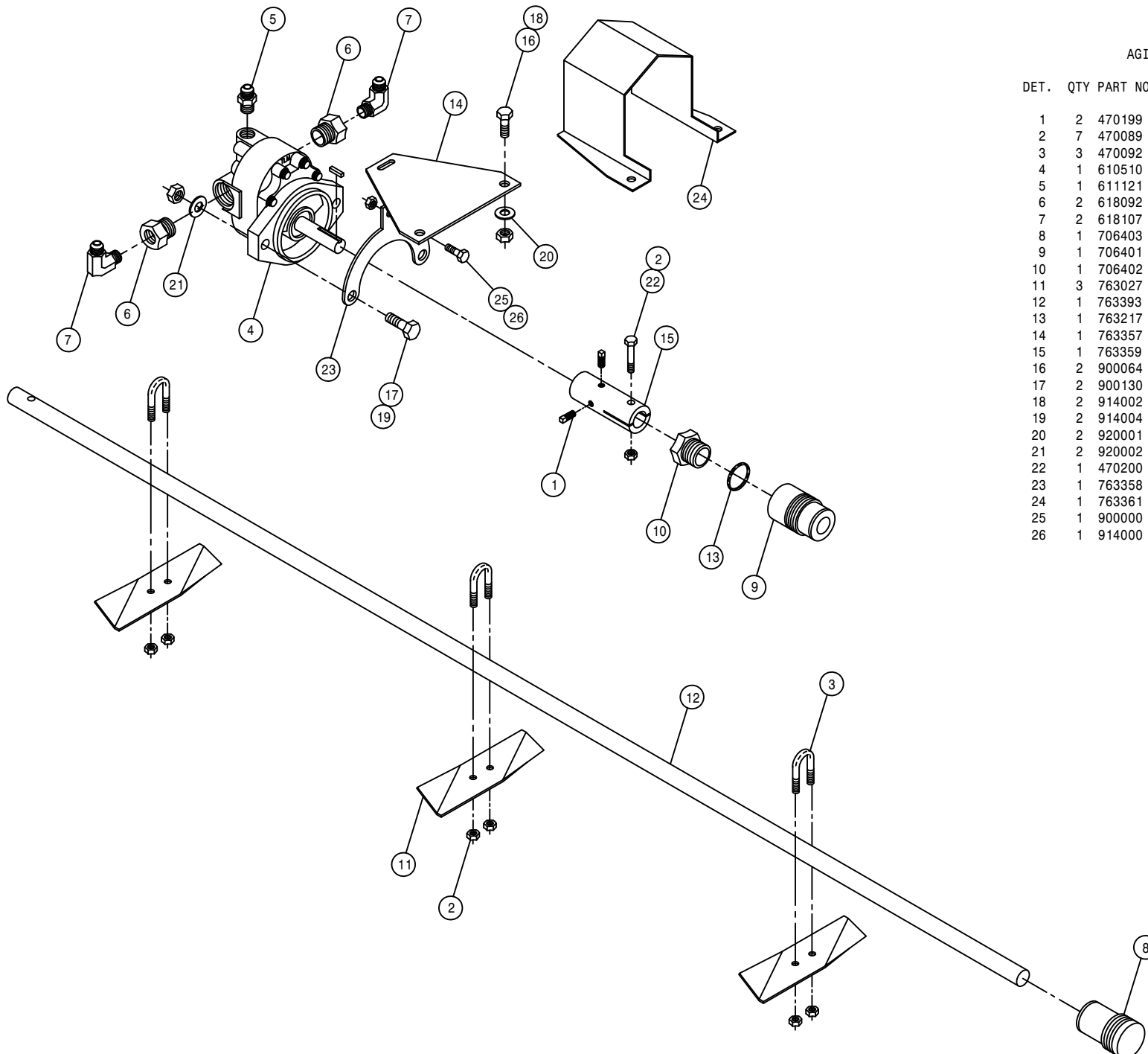

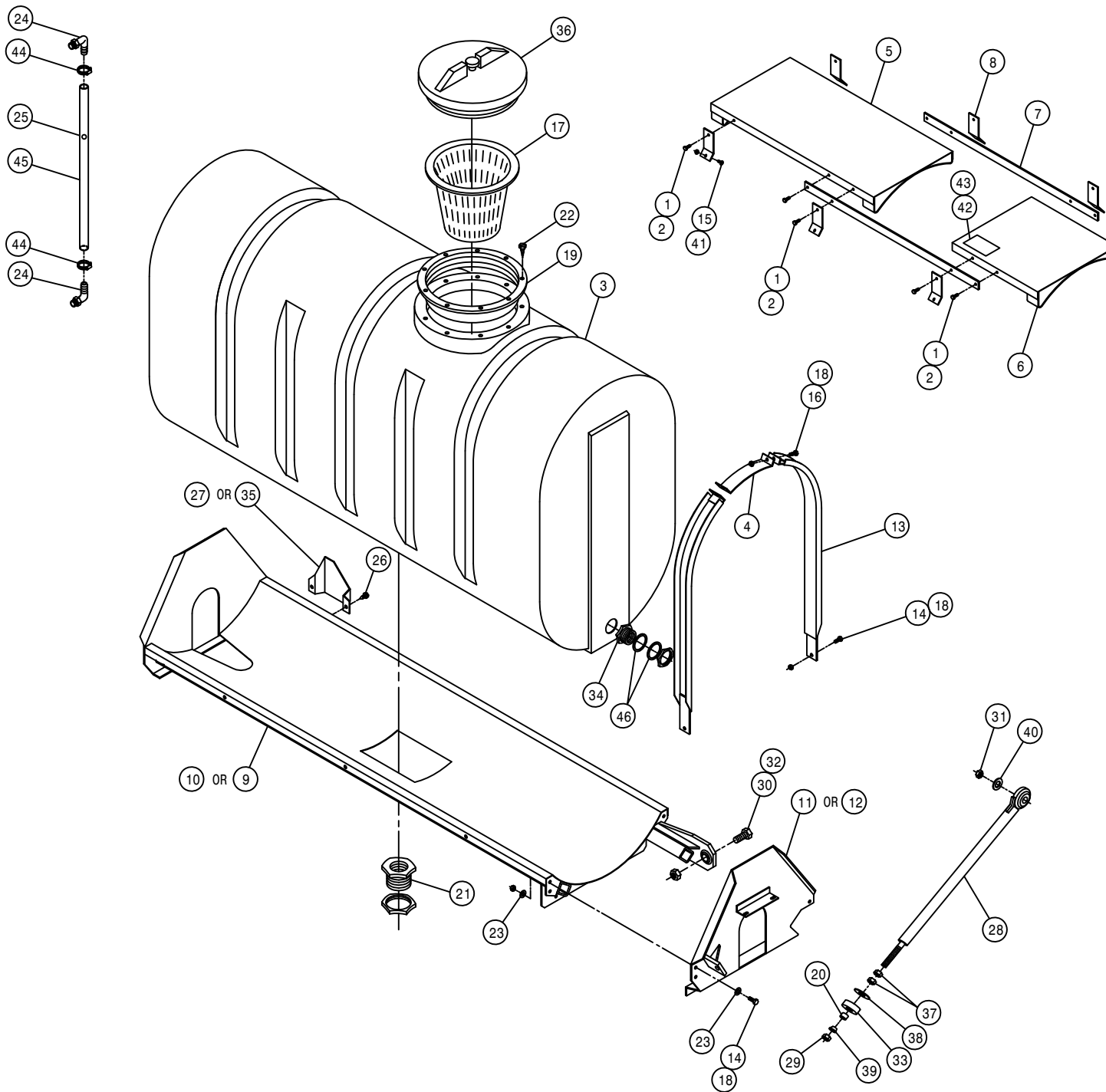

POLY 250 GALLON SOLUTION TANK ASSEMBLY

DET.	QTY	PART NO.	DESCRIPTION
1	10	470118	1/4UNC X 3/4 FLANGE HEX BOLT
2	10	470121	1/4UNC HEX FLANGE LOCK NUT
3	1	763439	250 GAL GRAY POLY SOLU TANK 94
4	3	763260	TOP STRAP 250 POLY TANK
5	1	763261	FRT CATWALK WLD 250 POLY 8250
6	1	763264	REAR CATWALK WLD 250 POLY8250
7	2	763266	CATWALK MTG STRAP 250POLY8250
8	6	763267	CATWALK MTG TAB 250 POLY 8250
9	1	763366	RH POLY TANK CRADLE WLD250 91
10	1	763367	LH POLY TANK CRADLE WLD250 91
11	1	763381	RH REAR CRADLE PLT WLD 250 91
12	1	763382	LH REAR CRADLE PLT WLD 250 91
13	6	763390	POLY TANK BAND WLD 250 91
14	12	900129	3/8UNC X 1" HEX BOLT
15	6	901064	5/16UNC X 3/4 CARR BOLT
16	6	906136	3/8UNC X 3" HEX BOLT FULLTHRD
17	1	763431	8" STRAINER BASKET, SOLU TANK
18	18	914004	3/8UNC HEX STOVER NUT
19	1	763409	10" THD'D RING FOR TANK LID
20	1	763468	TANK CRADLE SUPP BUSH,254 94
21	1	618604	1.50 PLASTIC FTG ASSY-POLYTNK
22	8	763410	S.S. SCREW FOR CAP RING
23	9	920002	3/8 SAE FLAT WASHER
24	2	618556	1/4NPT-90-1/2 HOSE BARB,POLY
25	1	763446	RED POLYPROPYLENE BALL 25/64"
26	2	472349	1/4 X 3/4 20THD-IN TEK TYPE
27	1	763451	RH SIGHT GAGE SHLD,POLY254 94
28	1	763464	TANK CRADLE SUPPORT WLD254 94
29	1	914012	3/4UNC HEX STOVER NUT
30	2	900534	1" UNC X 3" HEX BOLT
31	1	914010	5/8UNC HEX STOVER NUT
32	2	914016	1" UNC HEX STOVER NUT
33	1	470101	WASHER,2-1.03-.63 BLK NEO 65D
34	2	618548	1.25 PLASTIC FTG ASSY POLYTNK
35	1	763452	LH SIGHT GAGE SHLD,POLY254 94
36	1	763408	LID, THD'D W/VENT, POLY TANK
37	2	472334	3/4UNC HEX JAM NUT
38	1	483014	WASH,2"OD X 3/4 ID X 1/4 THK
39	1	763467	TANK CRADLE SUPP SWIVEL254 94
40	1	920005	5/8 SAE FLAT WASHER
41	6	914002	5/16UNC HEX STOVER NUT
42	1	342050	DECAL PLATE
43	4	472352	#10-24THD IN X 9/16 TEK TYP 3
44	2	520069	HOSE CLAMP NO 6 STAINLESS
45	1	601145	HOSE, 1/2 X 41 SIGHT GAUGE
46	4	763430	1 1/4 TANK FLANGE RUBBER SEAL

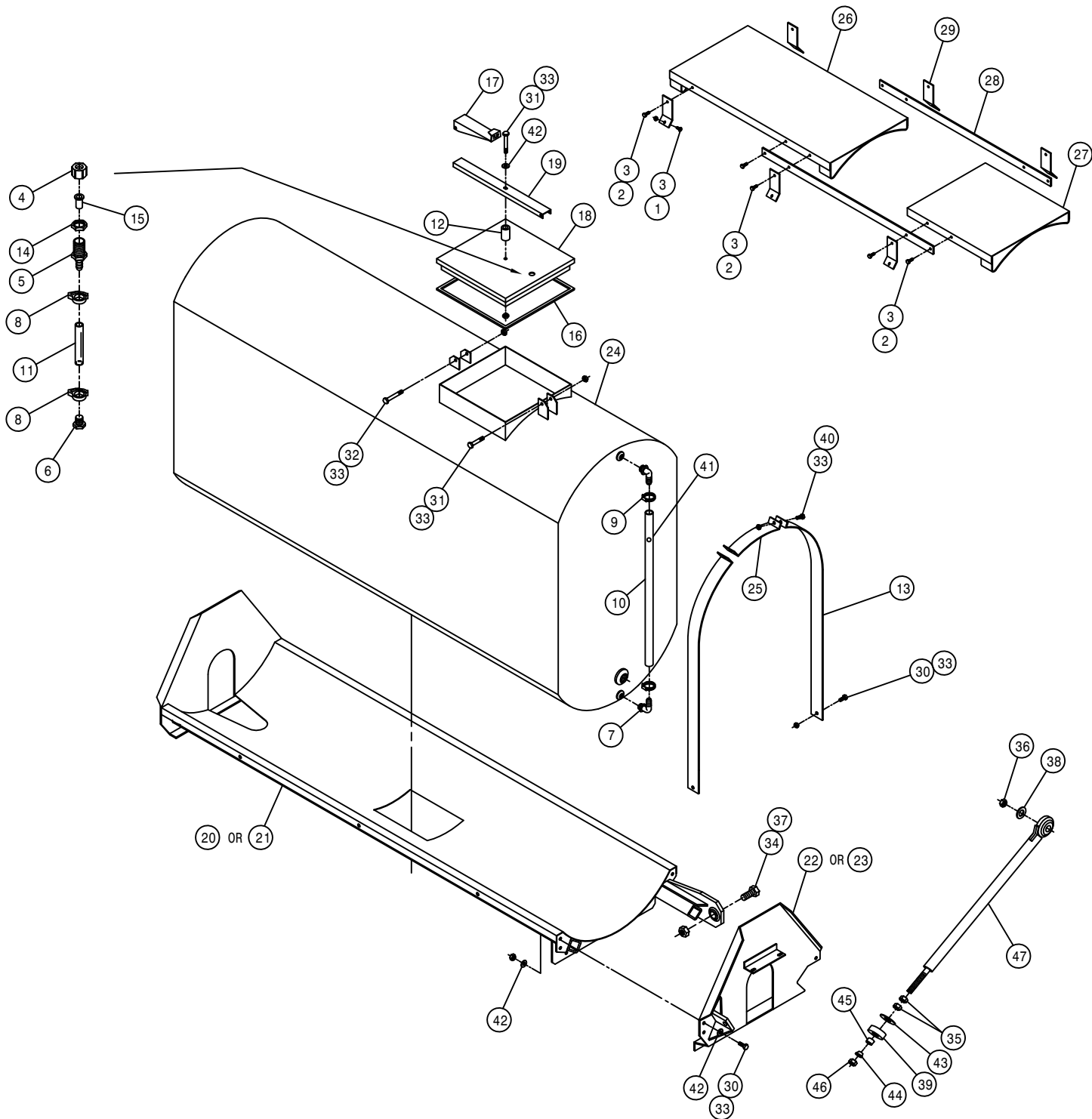

STAINLESS STEEL 250 GAL SOL TANK ASSEMBLY

DET.	QTY	PART NO.	DESCRIPTION
1	6	169072	1/4UNC X 5/8 CARR BOLT
2	10	470118	1/4UNC X 3/4 FLANGE HEX BOLT
3	16	470121	1/4UNC HEX FLANGE LOCK NUT
4	1	500005	CAP NUT .688FPS NYLON
5	1	500006	.38 H BARB X .69 MPS NYLON
6	1	500007	FTG .12 MNPT HEX PLUG NYLON
7	2	500017	.25NPT-.25 HOSE BARB 90 NYLON
8	2	520003	HOSE CLAMP NO 6 PLASTIC SNAP
9	2	520069	HOSE CLAMP NO 6 STAINLESS
10	1	601146	HOSE, 1/2 X 38 CLEAR
11	1	601216	SPRAY TNK VENT HOSE .38X3.50
12	1	601231	HOSE, 3/4 X 2 HI PRESS EPDM
13	6	763422	TANK BAND 250GAL SS 250
14	1	737858	TEE AND EL NUT .688 FPS
15	1	738859	STRAINER 50 MESH NYLON
16	1	760651	TANK LID GSKT 647
17	1	763163	SPRAY TANK LATCH HANDLE 647S
18	1	763164	SPRAY TANK LID WLD 647S
19	1	763166	TANK LID CHAN 647-S SIDE
20	1	763366	RH POLY TANK CRADLE WLD250 91
21	1	763367	LH POLY TANK CRADLE WLD250 91
22	1	763381	RH REAR CRADLE PLT WLD 250 91
23	1	763382	LH REAR CRADLE PLT WLD 250 91
24	1	763412	SS SPRAY TANK WLD 250GAL 250
25	3	763423	TANK BAND BINDER 250SS 250
26	1	763424	FRT CATWALK WLD,250SS TNK 250
27	1	763425	REAR CATWALK WLD,250SS TNK250
28	2	763428	CATWALK MTG STRIP 250SS 250
29	6	763429	CATWALK MTG TAB 250SS TNK 250
30	12	900129	3/8UNC X 1" HEX BOLT
31	2	900134	3/8UNC X 2 1/2 HEX BOLT
32	1	900138	3/8UNC X 3 1/2 HEX BOLT
33	21	914004	3/8UNC HEX STOVER NUT
34	2	900534	1" UNC X 3" HEX BOLT
35	2	472334	3/4UNC HEX JAM NUT
36	1	914010	5/8UNC HEX STOVER NUT
37	2	914016	1" UNC HEX STOVER NUT
38	1	920005	5/8 SAE FLAT WASHER
39	1	470101	WASHER,2-1.03-.63 BLK NEO 65D
40	6	900131	3/8UNC X 1 1/2 HEX BOLT
41	1	763446	RED POLYPROPYLENE BALL 25/64"
42	10	920002	3/8 SAE FLAT WASHER
43	1	483014	WASH,2"OD X 3/4 ID X 1/4 THK
44	1	763467	TANK CRADLE SUPP SWIVEL254 94
45	1	763468	TANK CRADLE SUPP BUSH,254 94
46	1	914012	3/4UNC HEX STOVER NUT
47	1	763464	TANK CRADLE SUPPORT WLD254 94

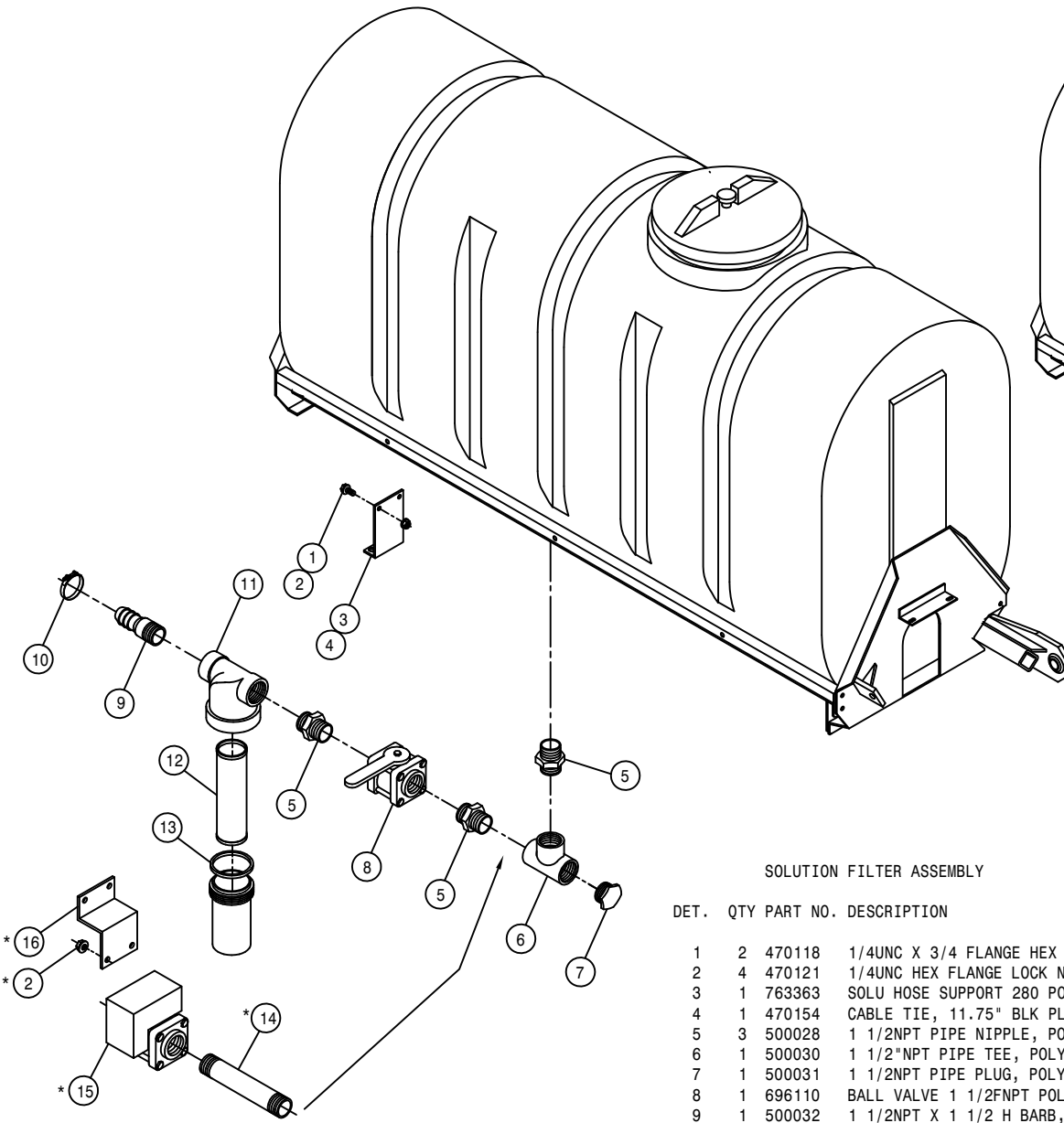

LEFT SOLUTION FILTER ASSEMBLY FOR D230 HP PUMP

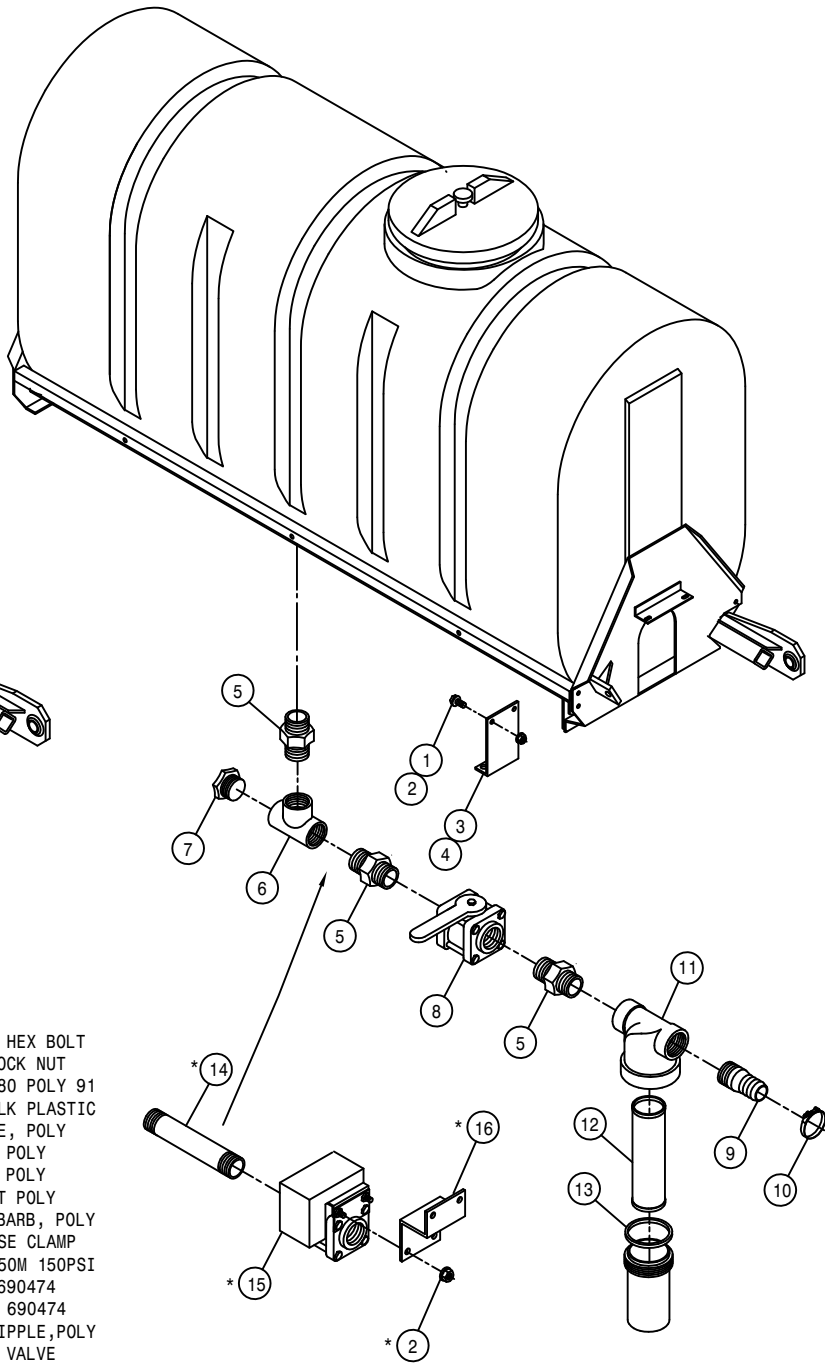

LEFT SOLUTION FILTER ASSEMBLY FOR BEAN 35 HP PUMP

SOLUTION FILTER ASSEMBLY

DET.	QTY	PART NO.	DESCRIPTION
	1	2 470118	1/4UNC X 3/4 FLANGE HEX BOLT
	2	4 470121	1/4UNC HEX FLANGE LOCK NUT
	3	1 763363	SOLU HOSE SUPPORT 280 POLY 91
	4	1 470154	CABLE TIE, 11.75" BLK PLASTIC
	5	3 500028	1 1/2NPT PIPE NIPPLE, POLY
	6	1 500030	1 1/2"NPT PIPE TEE, POLY
	7	1 500031	1 1/2NPT PIPE PLUG, POLY
	8	1 696110	BALL VALVE 1 1/2FNPT POLY
	9	1 500032	1 1/2NPT X 1 1/2 H BARB, POLY
	10	1 520133	1.81/2.06 T-BOLT HOSE CLAMP
	11	1 690474	1 1/2 LINE STRAINER50M 150PSI
	12	1 690475	50 MESH SCREEN FOR 690474
	13	1 690476	STRAINER GASKET FOR 690474
	14	1 500029	1 1/2NPT X 6 PIPE NIPPLE,POLY
	15	1 696161	1 1/2NPT ELECT SOLU VALVE
	16	1 763445	ELECT SOLU VLV SUPPORT 94

NOTE: ITEMS 2,14,15, AND 16 ARE USED WITH ELECTRIC VALVE OPTION.

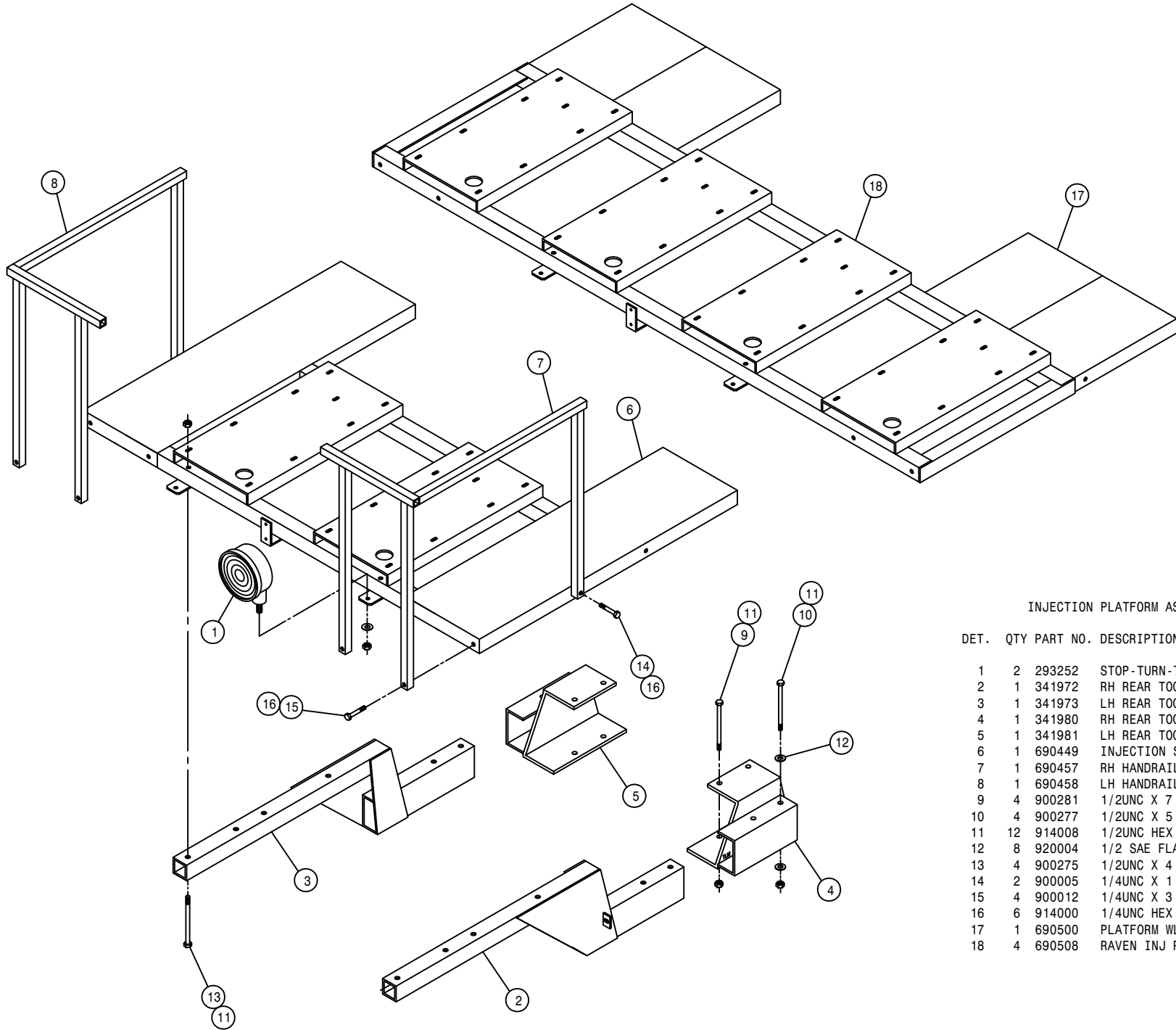

INJECTION PLATFORM ASSEMBLY

DET.	QTY	PART NO.	DESCRIPTION
1	2	293252	STOP-TURN-TAIL LAMP PED MT
2	1	341972	RH REAR TOOL BAR WLD 2XX 92
3	1	341973	LH REAR TOOL BAR WLD 2XX 92
4	1	341980	RH REAR TOOL BAR MT WLD 2XX
5	1	341981	LH REAR TOOL BAR MT WLD 2XX
6	1	690449	INJECTION SYS MT/PLATFORM WLD
7	1	690457	RH HANDRAIL WLD, INJ PLATFORM
8	1	690458	LH HANDRAIL WLD, INJ PLATFORM
9	4	900281	1/2UNC X 7 1/2 HEX BOLT
10	4	900277	1/2UNC X 5 1/2 HEX BOLT
11	12	914008	1/2UNC HEX STOVER NUT
12	8	920004	1/2 SAE FLAT WASHER
13	4	900275	1/2UNC X 4 1/2 HEX BOLT
14	2	900005	1/4UNC X 1 1/2 HEX BOLT
15	4	900012	1/4UNC X 3 1/2 HEX BOLT
16	6	914000	1/4UNC HEX STOVER NUT
17	1	690500	PLATFORM WLD, 3 & 4 UNIT SYS
18	4	690508	RAVEN INJ PUMP/TANK MT CHAN

HYPRO D230 PUMP ASSEMBLY

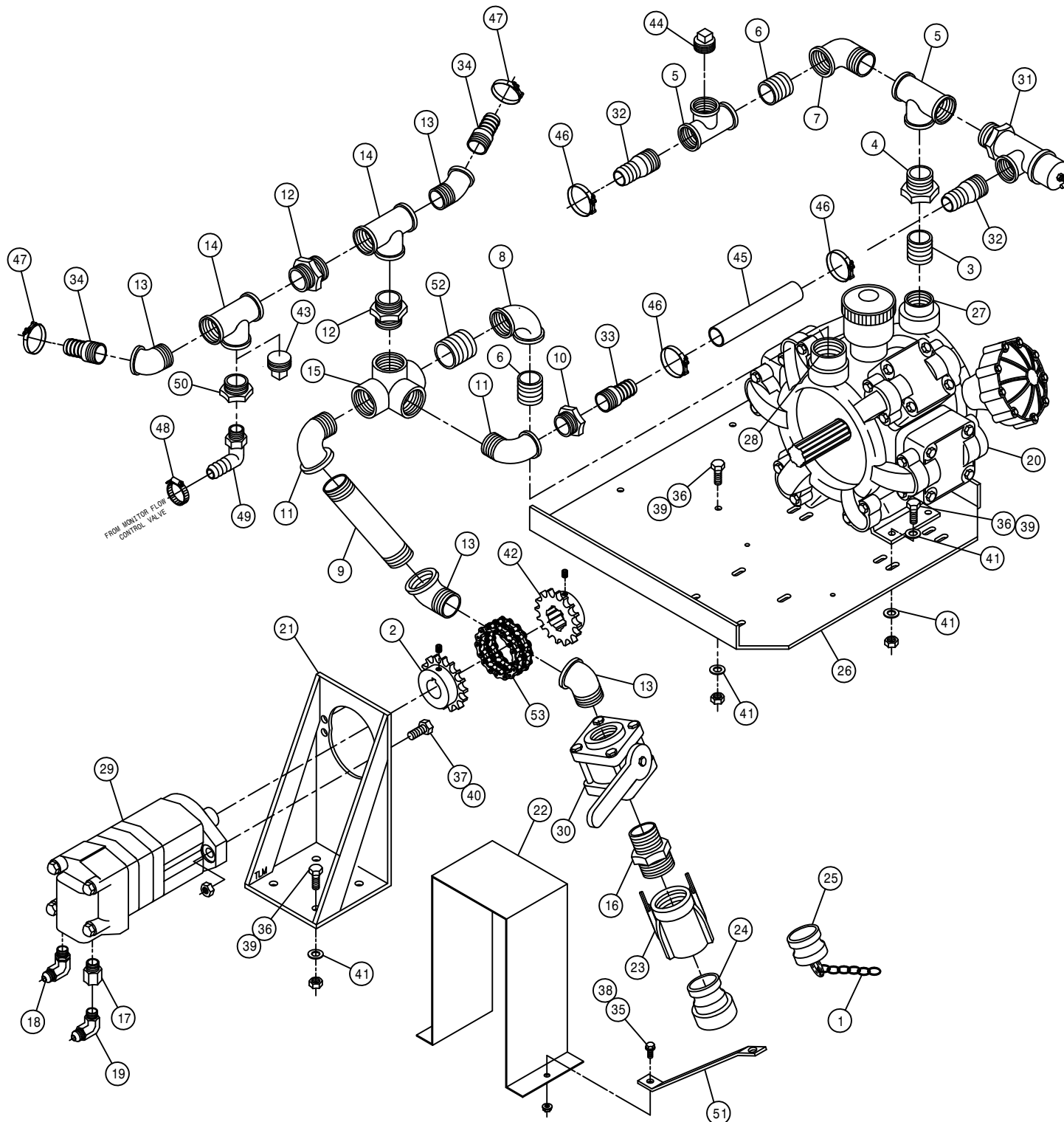

DET.	QTY	PART NO.	DESCRIPTION
1	1	160986	CHAIN, 12.00 LONG
2	1	220026	SPROCKET,40BS16,1.25ID,.312KE
3	1	505201	CLOSE NIPPLE 1.00NPT
4	1	506005	1 1/4 TO 1 RED BUSH BLK MAL
5	2	506105	BLK PIPE TEE 1.25NPT
6	2	506200	CLOSE NIPPLE 1.25NPT
7	1	506410	BLK PIPE ST EL 90DEG 1.25NPT
8	1	506415	RED EL 90 1 1/2 TO 1 1/4 MAL
9	1	500029	1 1/2NPT X 6 PIPE NIPPLE,POLY
10	1	500037	1 1/2"X 1 1/4NPT BUSH, POLY
11	2	500034	1 1/2NPT-90 ST EL, POLY
12	2	500028	1 1/2NPT PIPE NIPPLE, POLY
13	4	500035	1 1/2NPT-45 ST EL, POLY
14	2	500030	1 1/2"NPT PIPE TEE, POLY
15	1	507253	BLK PIPE SIDE OUTLET TEE 1.50
16	1	500038	2"X 1 1/2NPT REDU NIPPLE,POLY
17	1	618171	7/8MOR-3/4FOR ADPTR
18	1	618183	3/4MJIC-90-7/8MOR LBO
19	1	618241	3/4MJIC-90-3/4MOR LBO
20	1	690339	HYPRO D230 DIAPHRAM PUMP
21	1	690353	D150-D230 PUMP MTR MT WLD
22	1	690364	D150-D230 PUMP CPLR SHLD
23	1	690390	2.00 FEMALE NPT COUPLER
24	1	690391	2.00 FEMALE NPT ADPTR
25	1	690392	ADPTR PLG FOR 2.00 NPT COUPLR
26	1	690414	230 HYPRO PUMP MT PLT 280 90
27	1	690417	1FNPT ADAPTER, HYPRO D230
28	1	690418	1 1/4FNPT ADAPTER, HYPRO D230
29	1	695985	CHAR LYNN 2000 SER HYD MTR 79
30	1	696110	BALL VALVE 1 1/2FNPT POLY
31	1	699702	HAMILTON RELIEF VLV 200PSI
32	2	715660	HOSE BARB 1 1/4NPT X 1 1/4
33	1	500033	1 1/4NPT X 1 1/4 H BARB, POLY
34	2	500032	1 1/2NPT X 1 1/2 H BARB, POLY
35	2	900003	1/4UNC X 1" HEX BOLT
36	12	900129	3/8UNC X 1" HEX BOLT
37	2	900265	1/2UNC X 1 1/2 HEX BOLT
38	2	914000	1/4UNC HEX STOVER NUT
39	12	914004	3/8UNC HEX STOVER NUT
40	2	914008	1/2UNC HEX STOVER NUT
41	16	920002	3/8 SAE FLAT WASHER
42	1	220027	SPROCKET WLD,4016-1.375-6SPL
43	1	500031	1 1/2NPT PIPE PLUG, POLY
44	1	506101	PIPE PLUG 1.25NPT SQ HD
45	1	197120	HOSE 1 1/4 2-FBR BR BLK EPDM
46	3	520132	1.62/1.87 T-BOLT HOSE CLAMP
47	2	520133	1.81/2.06 T-BOLT HOSE CLAMP
48	1	520087	HOSE CLAMP NO 20 PLATED
49	1	500024	1"NPT-90-1"HOSE BARB, POLY
50	1	500036	1 1/2"X 1"NPT REDU BUSH, POLY
51	1	690480	VLV/CPLR SUPPORT,D230 PUMP 94
52	1	507019	CLOSE NIPPLE 1.50NPT
53	1	492084	CHAIN FOR 492083 4016

*NOTE: ITEMS 48,49, AND 50 ARE USED WITH THE MONITOR OPTION.

HYPRO D230 HP MANIFOLD ASSEMBLY

DET. QTY PART NO. DESCRIPTION

DET.	QTY	PART NO.	DESCRIPTION
1	1	503400	BLK PIPE ST EL 90DEG .50NPT
2	1	504210	RED BUSH 3/4 NPT X 1/2 NPT
3	3	505200	BLK PIPE ST EL 90DEG 1.00NPT
4	2	618281	1/2MNPT X 1/2 HOSE INSERT
5	3	696162	1" ELECT BALL VLV, 344AEC-2-1
6	1	695984	SOLU MANIF WLD D150-D230
7	2	695994	SOLU MANIF KEEPER OPTION
8	3	714560	1NPT X 1 HOSE BARB
9	1	715660	HOSE BARB 1 1/4NPT X 1 1/4
10	1	507015	RED BUSH 1.50NPT - 1.25FNPT
11	1	504900	PIPE PLUG .75NPT SQ HD
12	4	900072	5/16UNC X 3" HEX BOLT
13	4	914002	5/16UNC HEX STOVER NUT
14	1	341520	PRESSURE GAUGE MT WLD 8240X11
15	1	501450	BLK PIPE ST EL 90DEG .25NPT
16	1	503000	RED BUSH 1/2 TO 1/4 BLK MAL
17	1	701350	PRESS GAUGE 300LB BOT FILL
18	4	520080	HOSE CLAMP NO 10 STAINLESS
19	6	520087	HOSE CLAMP NO 20 STAINLESS
20	1	520132	1.62/1.87 T-BOLT HOSE CLAMP
21	1	197119	HOSE 1/2 2-FBR BR BLK EPDM X 206"
22	2	472349	1/4 X 3/4 20THD-IN TEK TYPE
23	2	197117	HOSE 1IN 2-FBR BR BLK EPDM X 288"
24	1	197117	HOSE 1IN 2-FBR BR BLK EPDM X 36"
25	1	506409	BLK PIPE ST EL 45DEG 1.25NPT

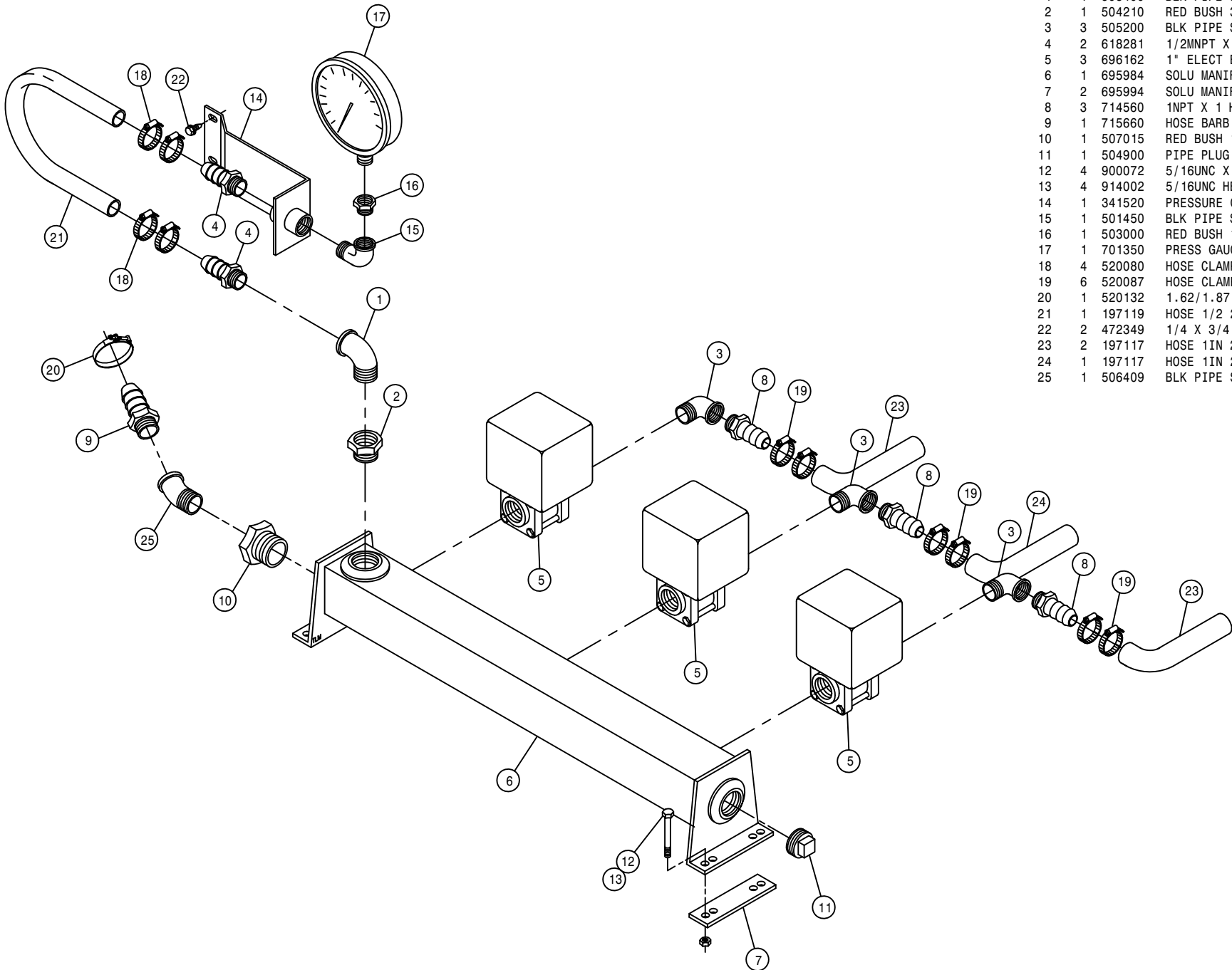

MONITOR FITTING ASSEMBLY FOR D230 PUMP

DET. QTY PART NO. DESCRIPTION

1	1	197117	HOSE 1IN 2-FBR BR BLK EPDM X 68.00
2	4	472349	1/4 X 3/4 20THD-IN TEK TYPE
3	1	505200	BLK PIPE ST EL 90DEG 1.00NPT
4	2	505201	CLOSE NIPPLE 1.00NPT
5	1	506005	1 1/4 TO 1 RED BUSH BLK MAL
6	1	506105	BLK PIPE TEE 1.25NPT
7	4	520132	1.62/1.87 T-BOLT HOSE CLAMP
8	2	520068	HOSE CLAMP NO 32 STAINLESS
9	1	690406	CONTROL VALVE, 1" POLY, RAVEN
10	1	696109	1 CONTROMATIC VALVE
11	1	714560	1NPT X 1 HOSE BARB
12	2	715660	HOSE BARB 1 1/4NPT X 1 1/4
13	1	520087	HOSE CLAMP NO 20 STAINLESS
14	1	690405	RFM 55 FLOW METER RAVEN
15	1	690481	CTRL VLV FTG SUPPORT WLD 94
16	1	197120	HOSE 1 1/4 2-FBR BR BLK EPDM X 96.00
17	1	197120	HOSE 1 1/4 2-FBR BR BLK EPDM X 4.00
18	1	197120	HOSE 1 1/4 2-FBR BR BLK EPDM X 115.00

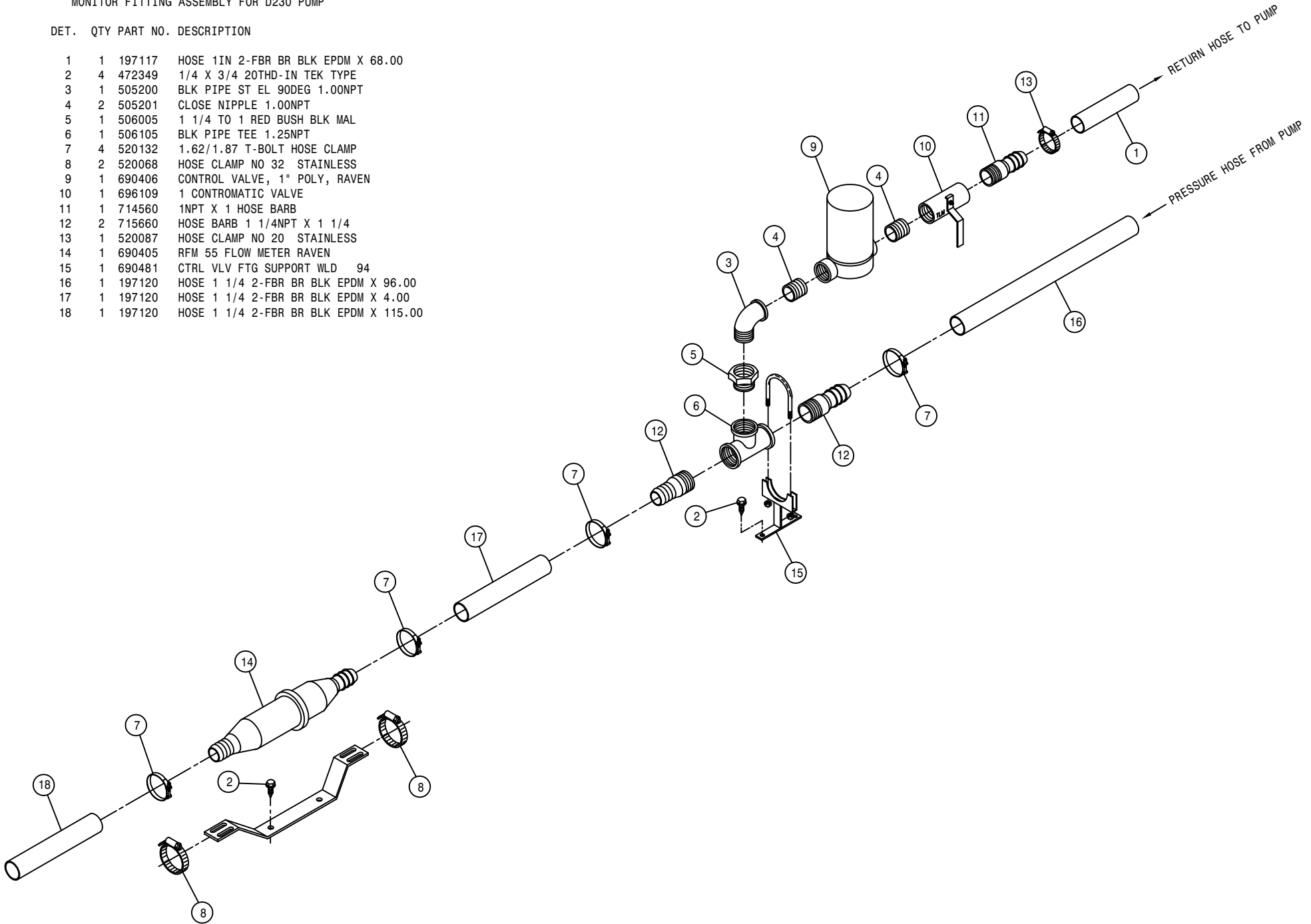

* NOTE: DETAILS 9, 60, 8, 32, AND 48 ARE USED WITH THE MONITOR OPTION.

DET.	QTY	PART NO.	DESCRIPTION
1	1	220004	CHAIN CPLR 1 1/4 BORE .31 KWY
2	2	470094	5/16UNC-1 3/8ID-3 U-BOLT
3	2	470118	1/4UNC X 3/4 FLANGE HEX BOLT
4	2	470121	1/4UNC HEX FLANGE LOCK NUT
5	1	492084	CHAIN FOR 4016 CHAIN COUPLER
6	1	492089	CHAIN CPLG HALF 1.375BORE4016
7	1	504210	RED BUSH 3/4 NPT X 1/2 NPT
8	5	504610	BLK PIPE ST EL 90DEG .75NPT
9	2	504702	CLOSE NIPPLE .75NPT
10	1	504960	BLK PIPE SIDE OUTLET TEE .75
11	1	507005	RED BUSH 1 1/2 TO 3/4 BLK MAL
12	3	507018	BLK PIPE ST EL 90DEG 1.50NPT
13	1	507007	BLK PIPE NIPPLE 1.50NPT-4.00
14	2	507019	CLOSE NIPPLE 1.50NPT
15	2	507024	BLK PIPE ST EL 45DEG 1.50NPT
16	3	507250	BLK PIPE TEE 1.50NPT
17	1	507717	RED BUSH 2 X 1 1/2
18	1	604006	MOTOR, HYD 7.7"
19	1	610305	3/4MJIC-90-3/4MNPT LBO
20	1	618131	7/8MOR-3/4FNPT ADPTR
21	1	618183	3/4MJIC-90-7/8MOR LBO
22	1	690250	35 GPM BEAN DOUBLE SHAFT PUMP
23	1	690291	HYD MTR BASE WLD BEAN 35GPM
24	1	690294	UNLOADER VLV MT BEAN 35GPM
25	1	690296	PUMP CPLR SHLD BEAN 35GPM
26	1	690442	250 X-11 BEAN 35 PUMP MT WLD
27	1	695943	UNLOADER VALVE, HYPRO 400-600
28	1	695944	SURGE TANK, HYPRO
29	1	696134	BALL VALVE 2IN FNPT POLY
30	1	690390	2.00 FEMALE NPT COUPLER
31	1	696201	ADAPTER, 2IN MALE FOR 696200
32	3	715450	3/4ANPTX3/4 HI HOSE BARB
33	5	900129	3/8UNC X 1" HEX BOLT
34	1	506610	BLK PIPE NIPPLE 1.50NPT-10.00
35	4	900130	3/8UNC X 1 1/4 HEX BOLT
36	2	900266	1/2UNC X 1 3/4 HEX BOLT
37	4	914002	5/16UNC HEX STOVER NUT
38	9	914004	3/8UNC HEX STOVER NUT
39	6	914008	1/2UNC HEX STOVER NUT
40	14	920002	3/8 SAE FLAT WASHER
41	1	690392	ADPTR PLG FOR 2.00 NPT COUPLR
42	1	160986	CHAIN, 12.00 LONG
43	1	690438	SOLU PUMP SUPPORT BRKT WLD 92
44	1	506000	RED BUSH 1 1/4 TO 3/4 BLK MAL
45	1	507706	CLOSE NIPPLE 2.00NPT
46	2	716003	1 1/2 X 1 1/2 HOSE BARB
47	1	504900	PIPE PLUG .75NPT SQ HD
48	6	520090	HOSE CLAMP NO 16 STAINLESS
49	1	611296	12RW087-12FJX-12FJX-26 H/A
50	1	601335	HOSE, 3/4 X 15 2BR BLK EPDM
51	2	520133	1.81/2.06 T-BOLT HOSE CLAMP
52	1	601236	HOSE, 1 1/2 X 228 2BR BLK EPDM
53	1	601188	HOSE, 1 1/2 X 58 2BR BLK EPDM
54	1	611297	12RW087-12FJX-12FJX-204 H/A
55	1	470227	KEY, 5/16 SQ X 1 1/2 LG
56	4	900264	1/2UNC X 1 1/4 HEX BOLT
57	4	470057	5/16 X 1/2 LG SQ HD SET SCR
58	3	618108	1 1/16MJIC-3/4MNPT ADPTR
59	1	690546	SHAFT GUARD WLD, BEAN 35
60	1	504955	BLK PIPE TEE .75NPT
61	3	690545	SLEEVE FOR 690250
62	3	690544	UMBRELLA WASHERS FOR 690250
63	3	690543	UMBRELLA FOR 690250
64	3	690542	O-RING FOR 690250
65	3	690613	PACKING CUP FOR 690250
66	1	690305	CYL PKG KIT FOR 690250 BEAN35
67	3	690614	PACKING WASHER FOR 690250
68	3	690541	NUT FOR 690250
69	8	690615	STUD, VALVE CHAMBER FOR 690250
70	3	690540	BRONZE NUT FOR 690250
71	6	690538	CYLINDER GASKET FOR 690250
72	3	690306	CYL, CERAMIC FOR 690250 BEAN
73	1	690382	CK VLV KIT FOR 690250 BEAN 35

TO SOLUTION MANIFOLD

63

189063

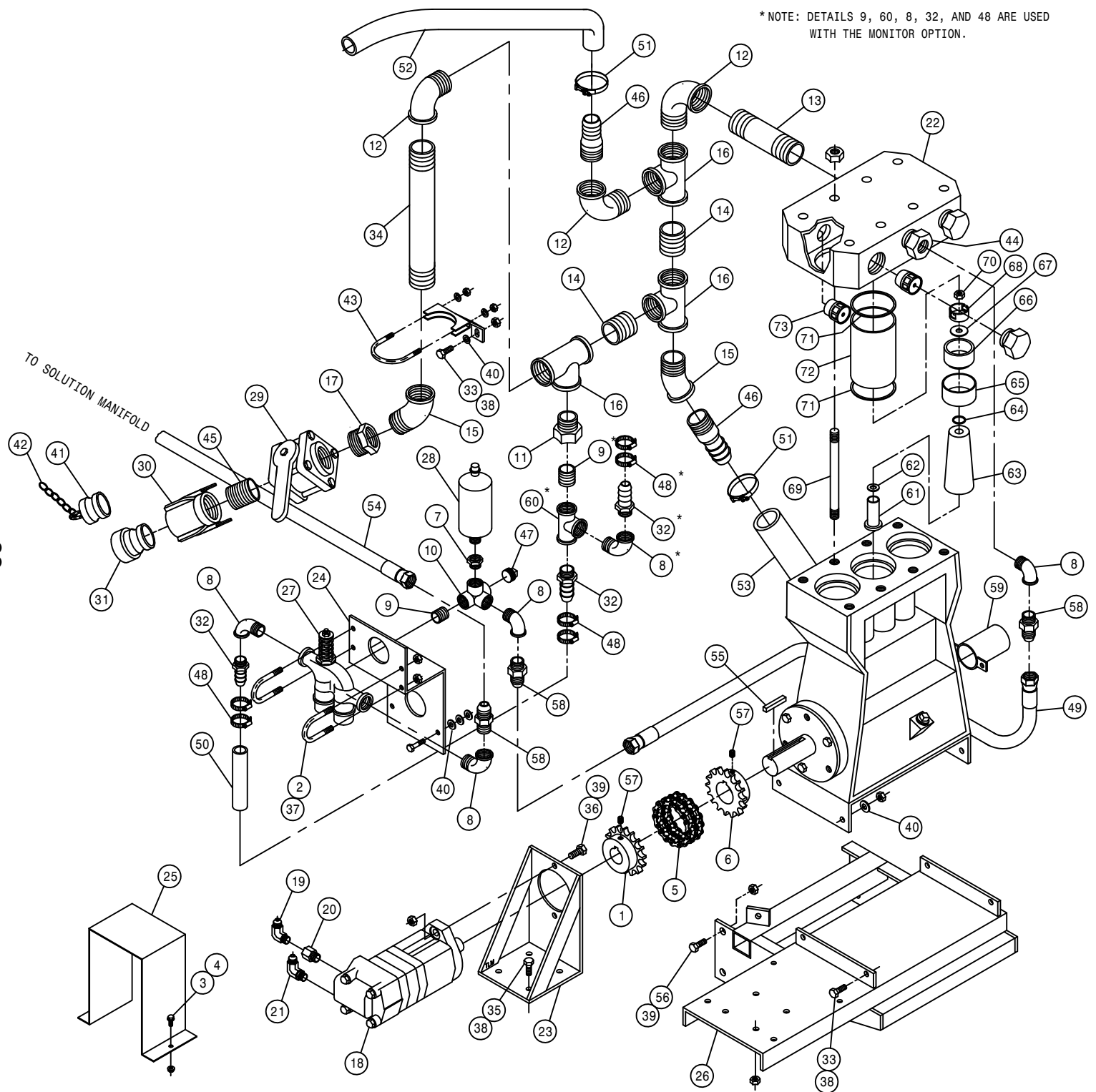

BEAN 35 HP SOLUTION MANIFOLD ASSEMBLY

DET. QTY PART NO. DESCRIPTION

1	1	341520	PRESSURE GAUGE MT WLD 8240X11
2	2	472349	1/4 X 3/4 20THD-IN TEK TYPE
3	1	503000	RED BUSH 1/2 TO 1/4 BLK MAL
4	1	504210	RED BUSH 3/4 NPT X 1/2 NPT
5	1	504600	BLK PIPE ST EL 45DEG .75NPT
6	4	504610	BLK PIPE ST EL 90DEG .75NPT
7	3	504702	CLOSE NIPPLE .75NPT
8	1	507720	PIPE PLUG 2.00NPT SQ HD
9	4	520080	HOSE CLAMP NO 10 STAINLESS
10	1	690486	ELECT BALL VLV BRACE 94
11	2	618281	1/2MNPT X 1/2 HOSE INSERT
12	1	601340	HOSE, 3/4 2FBR BLK EPDM X 276
13	3	695942	3/4" ELECT BALL VLV,KZCO EHII
14	1	695990	SOLU MANIF WLD JB2020-JB35
15	2	695994	SOLU MANIF KEEPER OPTION
16	1	701299	600 LB PRESS GAUGE BOT FILL
17	3	715450	3/4NPTX3/4 HI HOSE BARB
18	4	900077	5/16UNC X 4 1/4 HEX BOLT
19	4	914002	5/16UNC HEX STOVER NUT
20	1	503400	BLK PIPE ST EL 90DEG .50NPT
21	1	601334	HOSE, 1/2 2FBR BLK EPDM X 120
22	6	520090	HOSE CLAMP NO 16 STAINLESS
23	1	601339	HOSE, 3/4 2FBR BLK EPDM X 216
24	1	601337	HOSE, 3/4 2FBR BLK EPDM X 96
25	1	618108	1 1/16MJIC-3/4MNPT ADPTR
26	6	470121	1/4UNC HEX FLANGE LOCK NUT

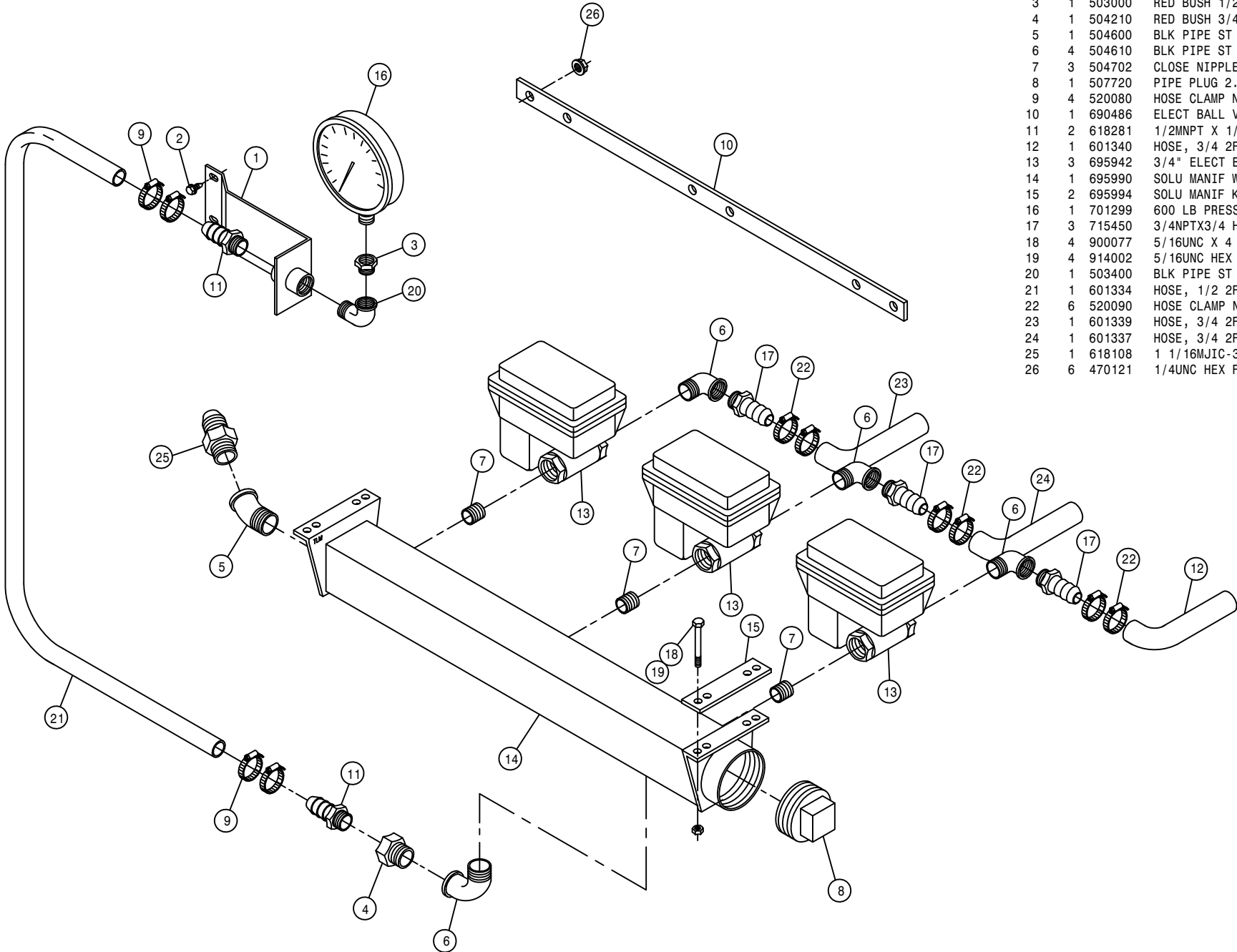

MONITOR FITTING ASSEMBLY FOR BEAN 35 PUMP

DET. QTY PART NO. DESCRIPTION

1	1	611299	12RW087-12FJX-12FJX-174	H/
2	4	472349	1/4 X 3/4 20THD-IN TEK TYPE	
3	1	505200	BLK PIPE ST EL 90DEG 1.00NPT	
4	2	505201	CLOSE NIPPLE 1.00NPT	
5	1	714331	1 NPT X 3/4 HOSE BARB	
6	1	505101	BLK PIPE TEE 1.00NPT	
7	1	505105	1MNPT HEX PIPE NIPPLE STL	
8	2	520068	HOSE CLAMP NO 32 PLATED	
9	1	690564	CONTROL VALVE,1" STEEL,RAVEN	
10	1	696109	1 CONTROMATIC VALVE	
11	1	611298	12RW087-12FJX-12FJX-15	H/
12	1	506005	1 1/4 TO 1 RED BUSH BLK MAL	
13	2	520090	HOSE CLAMP NO 16 PLATED	
14	1	690563	RFM 55A FLOW METER, RAVEN	
15	1	690481	CTRL VLV FTG SUPPORT WLD	94
16	2	618434	1 1/16MJIC-1MNPT ADPTR	
17	1	601372	HOSE, 3/4 2FBR BLK EPDM X 174	

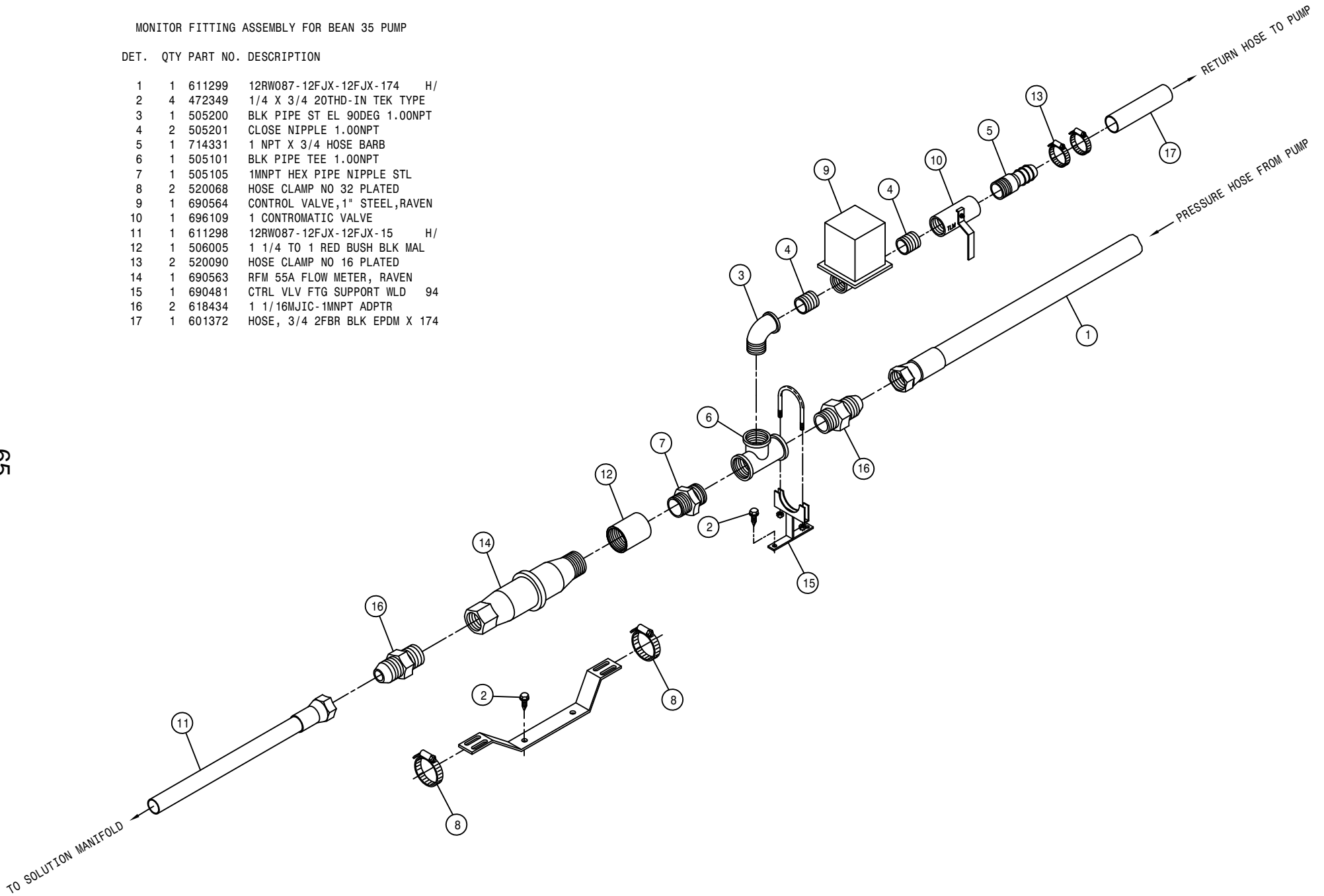

6FT 8-NOZL DROP ASSEMBLY

DET. QTY PART NO. DESCRIPTION

DET.	QTY	PART NO.	DESCRIPTION
1	3	160300	.50 PIPE CROSS WLD X-11 1981
2	1	160302	.50 PIPE TEE WLD X-11 1981
3	1	160307	DROP TUBE WLD X-11 1981
4	1	164270	6FT DROP MT WLD, X-11 96
5	1	160313	6FT DROP HANGER WLD X-11 81
6	2	164127	NOZL MT TUBE CLAMP,254X-11 96
7	1	410032	SPRING HOOK BOLT WLD 473
8	1	437452	BUSH, .50 SCH 80 X 2.00
9	4	473926	1/4UNC-3/4ID-1 1/4 UBOLT SQ
10	1	482006	SPRING FOR 473 ROLLER4IN LONG
11	2	501400	BLK PIPE ST EL 45DEG .25NPT
12	8	503000	RED BUSH 1/2 TO 1/4 BLK MAL
13	20	520055	HOSE CLAMP NO 12 PLATED
14	3	601288	HOSE, .50 2BR BLK X 12.00 EPDM
15	10	618281	1/2MNPT X 1/2 HOSE INSERT
16	8	737801	NOZL BODY .25NPT BRASS
17	8	738866	CAP NUT .688 FPS STEEL
18	1	900002	1/4UNC X 3/4 HEX BOLT
19	8	900023	1/4UNC X 2 1/4 HEX BOLT
20	1	900272	1/2UNC X 3 1/2 HEX BOLT
21	17	914000	1/4UNC HEX STOVER NUT
22	1	914008	1/2UNC HEX STOVER NUT
23	17	920000	1/4 SAE FLAT WASHER
24	3	504210	RED BUSH 3/4 NPT X 1/2 NPT
25	1	504400	BLK PIPE CROSS .75NPT
26	1	601333	HOSE, 1/2 2FBR BLK EPDM X 48
27	1	715450	3/4NPTX3/4 HI HOSE BARB
28	2	520090	HOSE CLAMP NO 16 PLATED
29	2	601199	HOSE, 1/2 2BR BLK X 105 EPDM
30	2	910008	1/2UNC HEX NUT
31	1	920504	1/2 LOCK WASHER

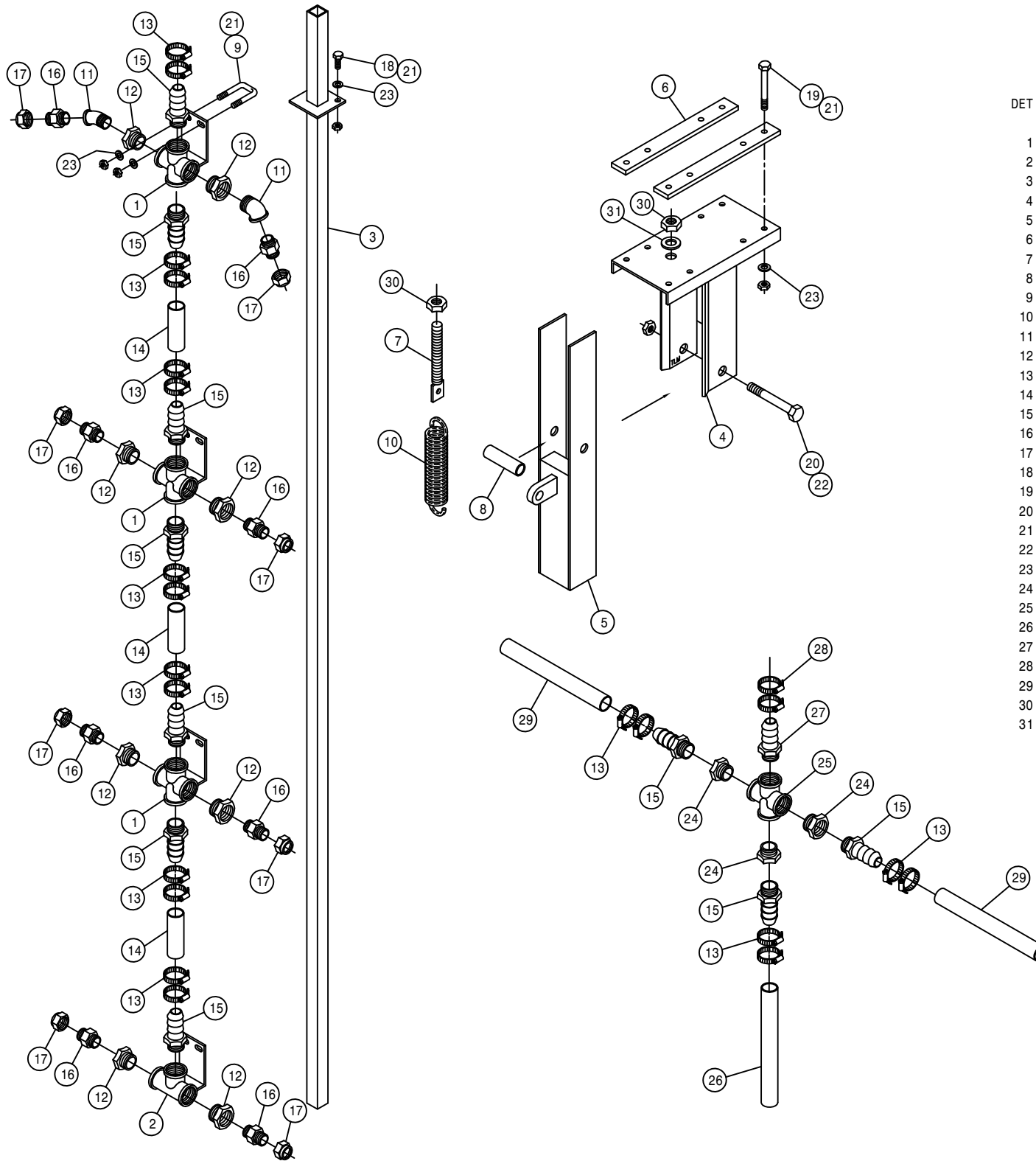

6FT 6-NOZL DROP ASSEMBLY

DET. QTY PART NO. DESCRIPTION

DET.	QTY	PART NO.	DESCRIPTION
1	2	160300	.50 PIPE CROSS WLD X-11 1981
2	1	160302	.50 PIPE TEE WLD X-11 1981
3	1	160307	DROP TUBE WLD X-11 1981
4	1	164270	6FT DROP MT WLD, X-11 96
5	1	160313	6FT DROP HANGER WLD X-11 81
6	2	164127	NOZL MT TUBE CLAMP, 254X-11 96
7	1	410032	SPRING HOOK BOLT WLD 473
8	1	437452	BUSH, .50 SCH 80 X 2.00
9	3	473926	1/4UNC-3/4ID-1 1/4 UBOLT SQ
10	1	482006	SPRING FOR 473 ROLLER 4IN LONG
11	2	501400	BLK PIPE ST EL 45DEG .25NPT
12	6	503000	RED BUSH 1/2 TO 1/4 BLK MAL
13	16	520055	HOSE CLAMP NO 12 PLATED
14	2	601249	HOSE, .50 2BR BLK X 16.63 EPDM
15	8	618281	1/2MNPT X 1/2 HOSE INSERT
16	6	737801	NOZL BODY .25NPT BRASS
17	6	738866	CAP NUT .688 FPS STEEL
18	1	900002	1/4UNC X 3/4 HEX BOLT
19	8	900023	1/4UNC X 2 1/4 HEX BOLT
20	1	900272	1/2UNC X 3 1/2 HEX BOLT
21	15	914000	1/4UNC HEX STOVER NUT
22	1	914008	1/2UNC HEX STOVER NUT
23	15	920000	1/4 SAE FLAT WASHER
24	3	504210	RED BUSH 3/4 NPT X 1/2 NPT
25	1	504400	BLK PIPE CROSS .75NPT
26	1	601333	HOSE, 1/2 2FBR BLK EPDM X 48
27	1	715450	3/4NPTX3/4 HI HOSE BARB
28	2	520090	HOSE CLAMP NO 16 PLATED
29	2	601199	HOSE, 1/2 2BR BLK X 105 EPDM
30	2	910008	1/2UNC HEX NUT
31	1	920504	1/2 LOCK WASHER

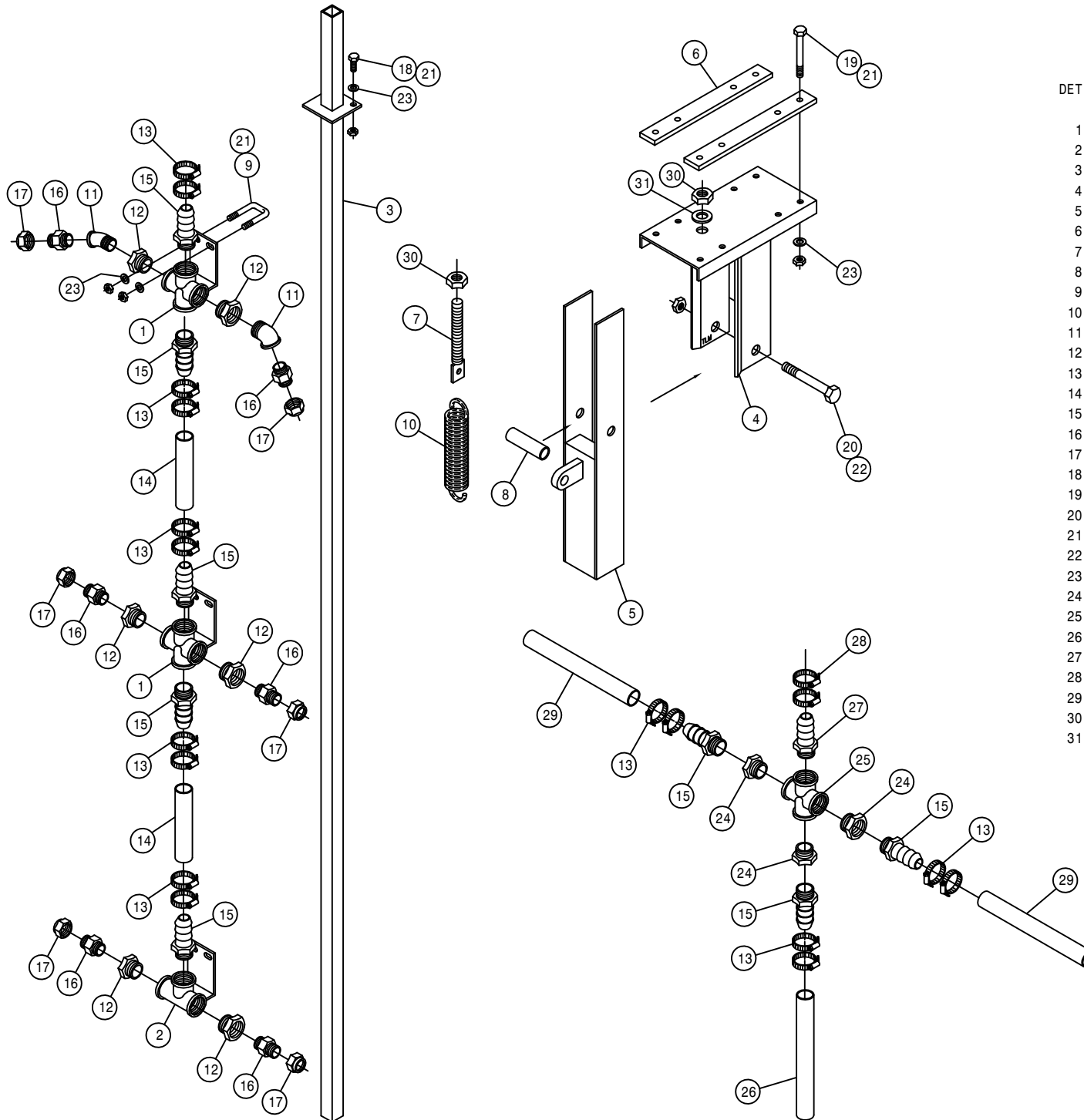

CROSS-SECTIONAL VIEW OF W1B TORQUE-HUB®

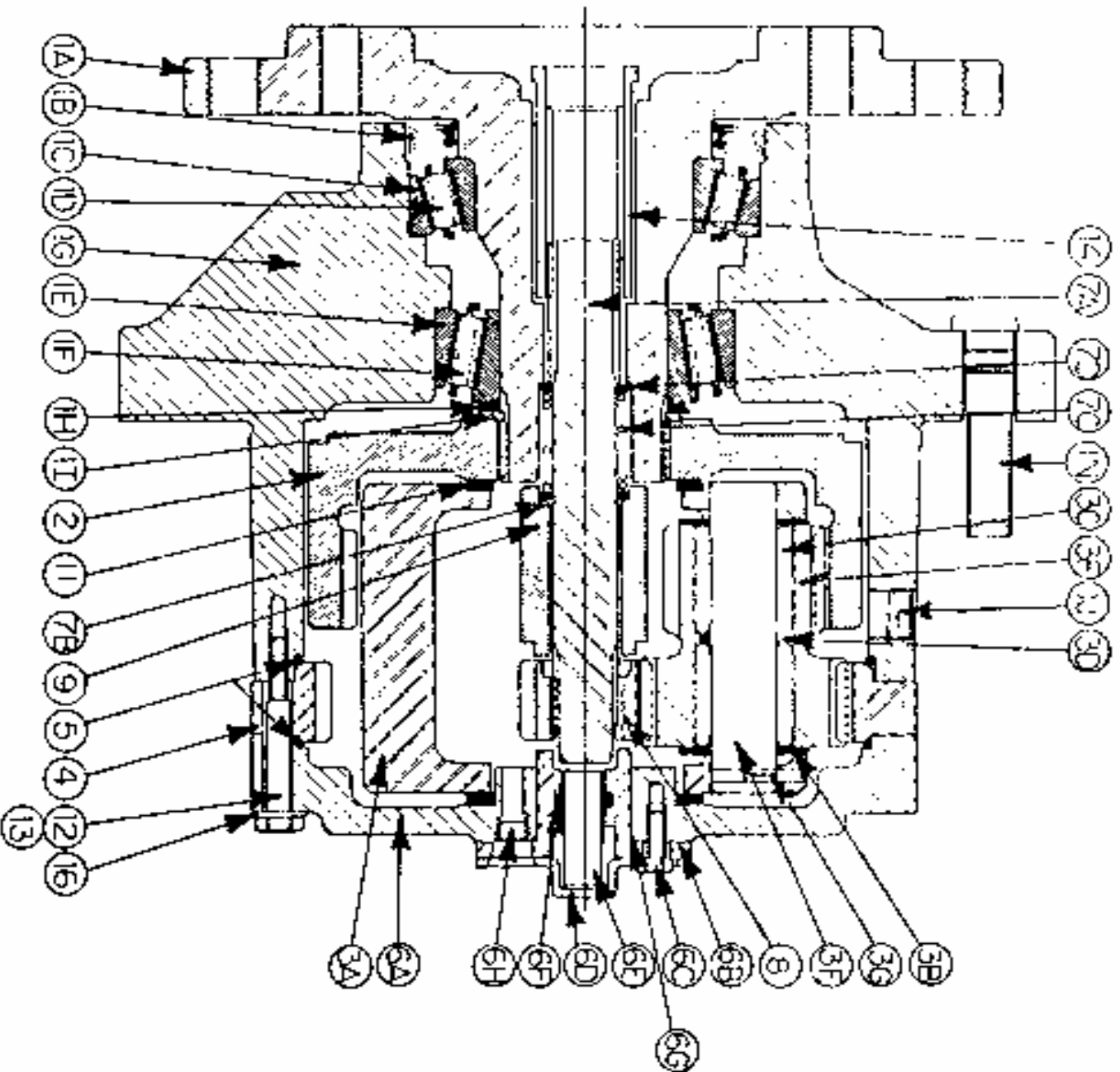

WHEEL DRIVE ASSEMBLY - 610516
W1BFNZ324

ITEMS	DESCRIPTION	PART NO.	QTY.
1	HUB-SPINDLE SUB-ASSEMBLY	-----	
1A	SPINDLE	610518	1
1B	SEAL	610519	1
1C	BEARING CUP	610520	1
1D	BEARING CONE	610521	1
1E	BEARING CUP	610907	1
1F	BEARING CONE	610908	1
1G	HUB	610522	1
1H	SPACER	610909	1
1I	RETAINER RING	610910	1
1J	PIPE PLUG	610147	2
1N	STUD	610523	9
2	INTERNAL GEAR	610148	1
3	CARRIER ASSEMBLY	610933	1
4	RING GEAR	610937	1
5	O-RING	610903	2
6	COVER ASSEMBLY	610155	1
6A	COVER	610149	1
6B	COVER CAP	610914	1
6C	BOLT	610150	4
6D	DISCONNECT CAP	610901	1
6E	DISCONNECT ROD	610915	1
6F	O-RING	610916	1
6G	O-RING	610917	1
6H	PIPE NIPPLE	610151	1
6I	ID PLATE	610152	1
7	INPUT SHAFT ASSEMBLY	610048	1
7A	INPUT SHAFT	610046	1
7B	RETAINING RING	610936	1
7C	SPRING	610145	1
7D	SPACER	610153	2
8	INPUT GEAR	610919	1
9	THRUST SPACER	610920	1
10	THRUST SPACER	610921	1
11	THRUST WASHER	610922	2
12	BOLT	610930	12
13	SHOULDER BOLT	610923	4
14	COUPLING	610037	1
16	FLAT WASHER	610049	16
NS	SEAL BOOT	610552	1

NOTICE

The following page contains decals for the model 254.

These decals can be obtained from Hagie Mfg. Co. and should be used whenever your machine is repainted or when the decals become worn, weathered, or faded.

Special attention should be paid to decals involving personal safety. They have been attached for your protection.

KEEP THEM IN PLACE.

Contact: Hagie Manufacturing Co.
Box 273
Clarion, Iowa 50525

254 X-11 DECALS

QTY.	PART NO.	DESCRIPTION	LOCATION
1	650320	EMERGENCY EXIT DECAL	ON LOWER REAR OF EXIT WINDOW
1	650335	CONSOLE COVER PANEL DECAL	ON CONSOLE SHEET METAL
1	650814	PARK BRAKE DECAL	NEAR PARK BRAKE
1	650822	SOLUTION PUMP DECAL	NEAR SOLUTION PUMP
1	650847	NO PASSENGER DECAL	REAR CORNER OF CAB
2	650848	SLIP OR FALL DECAL	2-ON EACH FUEL TANK
1	650849	ENGINE FUEL DECAL	NEAR FUEL TANK NECK
2	650850	CHEMICAL DECAL	ON SOLUTION TANK LIDS
2	650851	SHIELDS DECAL	ON SIDE OF TOP ENGINE COVER
1	650852	READ MANUAL DECAL	ON LEFT CAB DOOR
2	650330	X-11 DECAL	ON EACH ENGINE HOOD
1	650326	HAGIE DECAL	ON FRONT MAINFRAME SHIELD
1	650954	DIESEL DECAL	NEAR FUEL TANK NECK
1	650981	COOLING SYSTEM DECAL	NEAR RADIATOR CAP
1	650982	ELECTRICAL DECAL	RIGHT HAND SIDE OF OIL TANK
4	650985	WHEEL BOLT TORQUE DECAL	ON EACH WHEEL RIM
1	650322	DECAL SET, HAGIE 254 STRIPE	ON EACH ENGINE HOOD
1	650329	SPRAY CONTROL/TRAC VLV	ON INSTRUMENT PANEL
1	650327	254 SIGHT GAGE DECAL	ON EACH SOLUTION TANK
2	650324	RED STRIPE DECAL	ON EACH TANK SHIELD
1	650337	ELECTROCUTION HAZERD DECAL	ON LOWER REAR OF EXIT WINDOW
1	650339	HYD, OIL INJECTION DECAL	ON LEFT CAB DOOR
1	650347	NOTICE-R134A CHARGE DECAL	NEXT TO A/C COMPRESSOR

*NOTE:
 REFER TO DETAIL 73 TO CHECK AUX. SYSTEM - 1850 PSI
 REFER TO DETAIL 67 TO CHECK LIMIT SETTING - 4500 PSI
 REFER TO DETAIL 96 TO CHECK CHARGE PRESSURE - 380 PSI

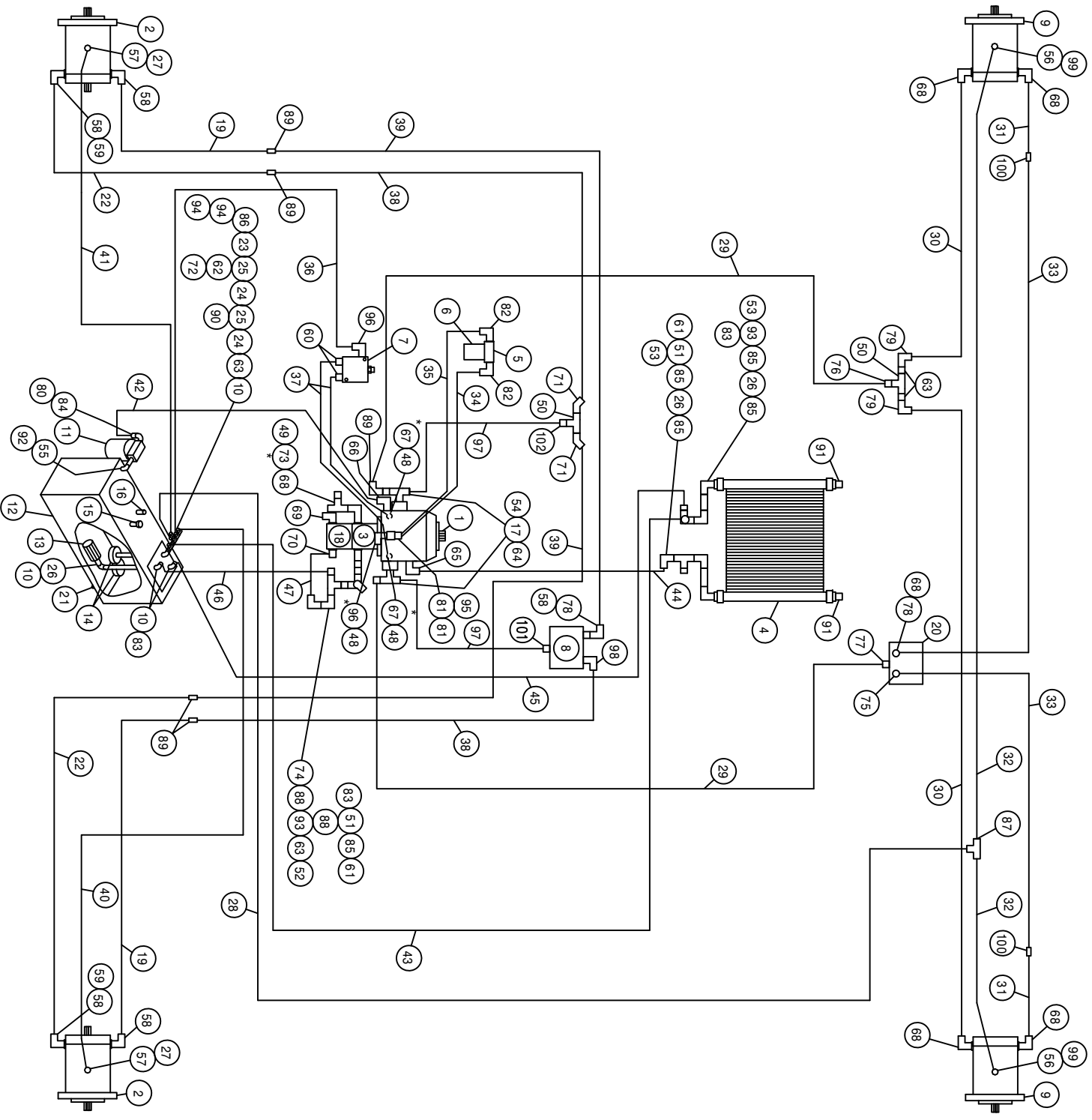

254 X-11 FWD WITH AGITATION HYD SCHEM 99
REFERENCE DRAWING NO. 498552S1

DET.	QTY	PART NO.	DESCRIPTION	DET.	QTY	PART NO.	DESCRIPTION
1	1	606902	SUND 100CC PUMP,B-MT W/FILT	52	1	610300	3/4MJC-3/4MNPT ADPTR
2	2	610557	SUND M35-3102 WHL MTR W/SHFT	53	2	714331	1 NPT X 3/4 HOSE BARB
3	1	606932	SUND GEAR PUMP,1.60CT,SPLINED	54	2	618599	1 5/16MOR BRANCH TEE-1 5/16MJ
4	1	618606	OIL COOLER, BLISSFIELD 65027	55	1	506303	BLK PIPE EL 90DEG 1.25NPT
5	1	605608	HYD FILTER HEAD, DONALDSON	56	2	618310	9/16MJC-7/8MOR ADPTR
6	1	605609	HYD FILTER ELEMENT, DONALDSON	57	2	618172	7/8MOR-9/16FOR ADPTR
7	1	610580	REMOTE FLUSHING VALVE, SUND	58	5	618248	1 1/16MJC-90-1 1/16MOR LBO
8	1	610609	TRACTION VL.V.66S,40GPM	59	2	618529	1 1/16MJ-45-1 1/16FJ SWIV LBO
9	2	610571	SUND M35-3002 WHL MTR	60	2	618126	9/16MJC-9/16MOR ADPTR
10	4	505300	BLK PIPE EL 90DEG 1.00NPT	61	2	716000	3/4 HOSE BARB-90-1MNPT
11	1	605601	GRESEN FILTER 10 MICRON 40GPM	62	1	504001	RED BUSH 3/4 X 1/4 BLK MAL
12	1	760097	OIL TANK WLD 8240 1982	63	4	505213	RED BUSH 1 X 3/4 BLK MAL
13	1	605600	MICHIGAN RESERVOIR FILTER	64	2	618541	1 5/16FJIC-1 1/16MJC ADPTR
14	2	605603	LINE SUMP DIFFUSER	65	1	618118	3/4 HOSE BARB-90-1 1/16MOR
15	1	611052	FILLER BREATHER 3/4ANPT	66	1	618626	1 1/4 HOSE BARB-45-1 5/8MOR
16	1	614453	DIPSTICK, 8IN	67	2	618629	9/16MOR BRANCH TEE-9/16MJC
17	2	618598	1" 4-BOLT FLG X 1 5/16 FOR	68	6	618535	7/8MJC-90-1 1/16MOR LBO
18	1	606929	SUND GEAR PUMP .66CT, SPLINED	69	1	611128	7/8MJC-90-7/8MOR LBO
19	2	614700	FRT HYD TUBE ASSY 250 X-11 92	70	1	618075	3/4 HOSE BARB-1 1/16MOR
20	1	610469	TRACTION VL.V.66S,40GPM,BY-PASS	71	2	618339	1 1/16MJC-45-1MNPT LBO
21	1	501102	1/4 PIPE PLUG	72	1	618520	1/4MNPT RUN TEE-9/16MJC
22	2	614701	REAR HYD TUBE ASSY 250 X11 92	73	1	618333	7/8FJIC SW RUN TEE-7/8MJC
23	1	504210	RED BUSH 3/4 NPT X 1/2 NPT	74	1	618090	1 5/16MOR-1FNPT ADPTR
24	2	504702	CLOSE NIPPLE .75NPT	75	1	618589	7/8MJC-90-1 5/16MOR LBO
25	2	504955	BLK PIPE TEE .75NPT	76	1	618434	1 1/16MJC-1MNPT ADPTR
26	3	505203	BLK PIPE NIPPLE 1.00NPT-4.00	77	1	618308	1 1/16MJC-1 5/16MOR ADPTR
27	2	618425	9/16MJC-45-9/16MOR LBO	78	2	618312	1 5/16MOR-1 1/16FOR ADPTR
28	1	615619	06C1T-06FJX-06FJX-144	79	2	618156	7/8MJC-90-3/4MNPT LBO
29	2	614685	08C2AT-12FJX-12FJX-106	80	1	506410	BLK PIPE ST EL 90DEG 1.25NPT
30	2	614706	08TWM-10FJX90-10FJX-143	81	2	618327	3/4MJC-7/8MOR ADPTR
31	2	615681	FRT WHL MTR HYD TUBE ASSY,X11	82	2	618474	3/4MJC-90-1 1/16MOR LBO
32	2	615449	06C1T-06FJX-06FJX-126	83	4	714560	1NPT X 1 HOSE BARB
33	2	614705	08TWM-10FJX-10FJX-143	84	1	715660	HOSE BARB 1 1/4NPT X 1 1/4
34	1	616034	08C1T-08FJX-08FJX-17	85	5	505200	BLK PIPE ST EL 90DEG 1.00NPT
35	1	615633	08C1T-08FJX-08FJX-23	86	1	618018	9/16MJC-1/2MNPT ADPTR
36	1	616048	04C1T-06FJX-06FJX-35	87	1	618019	9/16MJC UNION TEE
37	2	616043	04C1T-06FJX-06FJX-23	88	2	505105	1MNPT HEX PIPE NIPPLE STL
38	2	614683	10C2AT-12MJ-12FJX90-60	89	5	618191	1 1/16MJ-90-1 1/16FJ SWIV LBO
39	2	614549	10C2AT-12MJ-12FJX90-70	90	1	713220	HOSE BARB 3/4 NPT X 3/4
40	1	614644	06C1T-06FJX-06FJX-140	91	2	505102	PIPE PLUG 1.00NPT SQ HD
41	1	614704	06C1T-06FJX-06FJX-156	92	1	506602	PIPE NIPPLE 1 1/4NPT-2 1/2
42	1	601380	HOSE, 1 1/4 X 35 1FBR-1SPI	93	2	505098	SIDE OUTLET EL 90DEG 1.00NPT
43	1	601304	HOSE, 3/4 2BR RED X 100 LG	94	2	618486	9/16FJIC SW RUN TEE-9/16MJC
44	1	601112	HOSE, 3/4 X 84 2BR RED	95	1	618609	3/4MJC-90-3/4FJIC SWIV LBO
45	1	601255	HOSE, 1.00 2BR RED X 104 LG	96	2	618119	9/16MJC-90-9/16MOR LBO
46	1	601381	HOSE, 1 X 39 1FBR-1SPI	97	2	614718	HYD TUBE ASSY, 254 X-11 96
47	1	601383	HOSE, 3/4 X 8 1FBR-1SPI	98	1	618302	1 1/16MJC-90-1 5/16MOR LBO
48	3	618531	9/16FJIC CAP NUT	99	2	618634	9/16MJC-45-9/16FJIC SWIV LBO
49	1	618328	7/8FJIC CAP NUT	100	2	618456	7/8MJC UNION
50	2	618575	1FNPT PIPE TEE STL	101	1	618178	1 5/16MJC-90-1 5/16MOR LBO
51	2	505101	BLK PIPE TEE 1.00NPT	102	1	618437	1 5/16MJC-90-1MNPT LBO

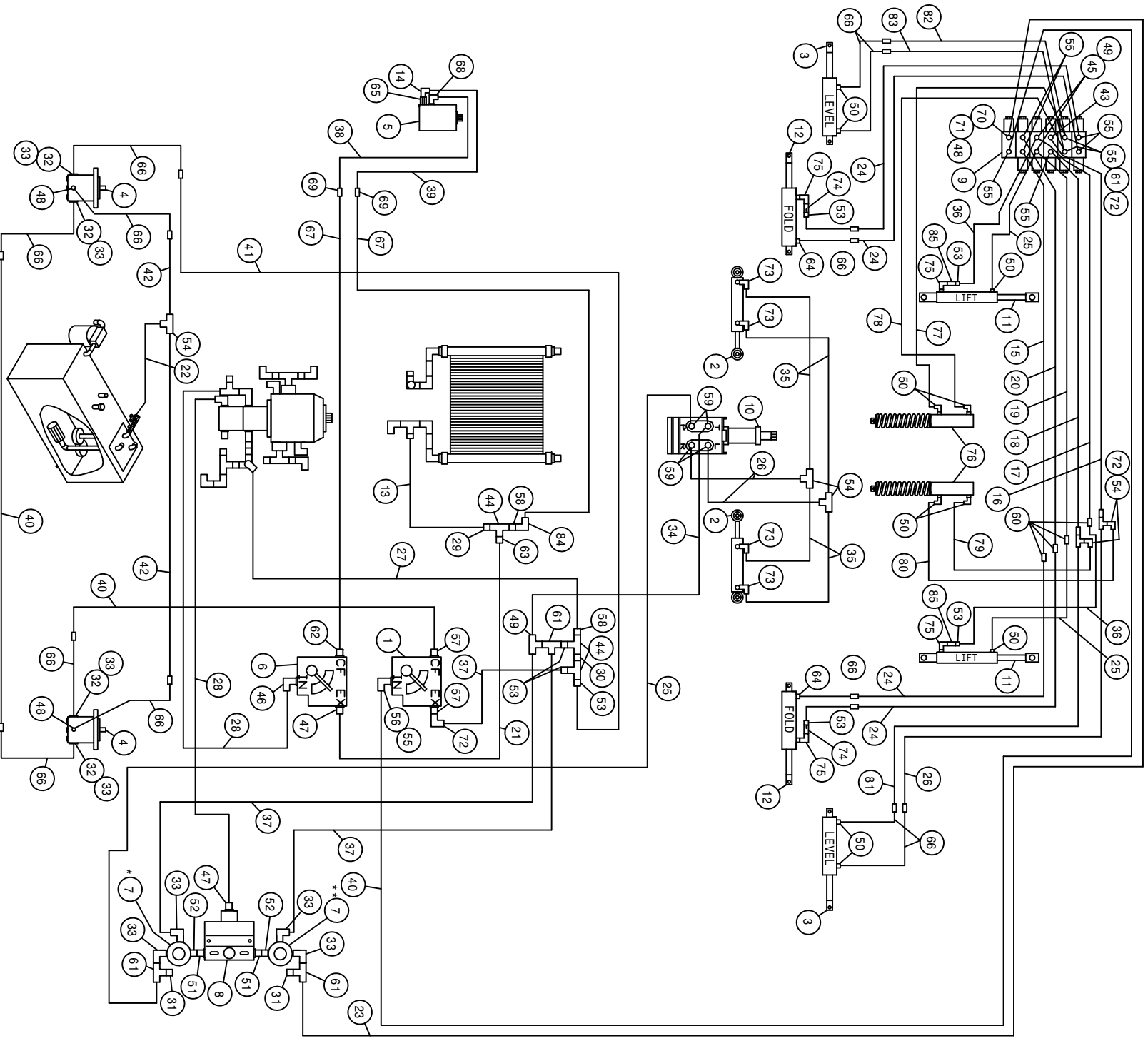

NOTE: REFER TO DETAIL 7 RELIEF PRESSURE SETTING.
 *STEERING RELIEF SETTING - 1850 PSI
 **BOOM RELIEF SETTING - 2650 PSI

254 X-11 FWD WITH AGITATION HYD SCHEM 99
REFERENCE DRAWING NO. 498552S2

DET.	QTY	PART NO.	DESCRIPTION	DET.	QTY	PART NO.	DESCRIPTION
1	1	606827	FLO CONT FCS1 0-3 VARI 7/8FOR	44	3	503820	BLK PIPE TEE .50NPT
2	2	620080	STRG CYL ASSY 1.50 X 6.0 1985	45	2	618126	9/16MJIC-9/16MOR ADPTR
3	2	620585	LEVEL CYL ASSY, 2 X 10	46	1	611128	7/8MJIC-90-7/8MOR LBO
4	2	610510	CESSNA GEAR MOTOR 1.48CI	47	2	611126	7/8MJIC-7/8MOR ADPTR
5	1	604006	MOTOR, HYD 7.7"	48	3	611121	9/16MJIC-1/4MNPT ADPTR
6	1	606818	FLO CONT FCR51 0-16GPM 7/8FOR	49	3	618514	9/16FJ SW BRANCH TEE-9/16MJ
7	2	607512	RELIEF VALVE, RL50, 1850 PSI	50	10	611122	9/16MJIC-90-1/4MNPT LBO
8	1	607504	FLO DIV B50 2-8GPM 7/8 FOR	51	2	618072	7/8MOR-1/2FNPT ADPTR
9	1	610569	6 SECT, 5 FUNCION HYD VLV, EATON	52	2	500000	1/2MNPT HEX PIPE NIPPLE STL
10	1	749150	STRG MTR NON-LOAD REACT 1008	53	7	618018	9/16MJIC-1/2MNPT ADPTR
11	2	620701	LIFT CYL ASSY, 2.50 X 14.00" 99	54	5	618019	9/16MJIC UNION TEE
12	2	620595	FOLD CYL ASSY, 2 X 10 IN	55	9	618119	9/16MJIC-90-9/16MOR LBO
13	1	601332	HOSE, 3/4 X 40 2BR RED	56	1	618172	7/8MOR-9/16FOR ADPTR
14	1	610305	3/4MJIC-90-3/4MNPT LBO	57	2	618310	9/16MJIC-7/8MOR ADPTR
15	1	615647	FOLD HYD TUBE ASSY, IN 254X11	58	2	611147	3/4MJIC-1/2MNPT ADPTR
16	1	615645	LEVEL HYD TUBE ASSY, UP 254X11	59	4	618496	9/16MJIC-45-3/4MOR LBO
17	1	615643	LIFT HYD TUBE ASSY, UP 254X11	60	4	619010	9/16MJIC UNION
18	1	615646	LEVEL HYD TUBE ASSY, DN 254X11	61	5	618486	9/16FJIC SW RUN TEE-9/16MJIC
19	1	615644	LIFT HYD TUBE ASSY, DN 254X11	62	1	618327	3/4MJIC-7/8MOR ADPTR
20	1	615648	FOLD HYD TUBE ASSY, OUT 254X11	63	1	618325	7/8MJIC-1/2MNPT ADPTR
21	1	615521	10CIT-10FJX-10FJX-18	64	2	614365	RESTRICTOR ELBOW ASSY .042DIA
22	1	615452	06CIT-06FJX-06FJX-16	65	1	618131	7/8MOR-3/4FNPT ADPTR
23	1	614159	04CIT-06FJX-06FJX-169	66	14	614335	04CIT-06FJX-06MJ-24
24	4	615442	04CIT-06FJX-06FJX-55	67	2	614622	08CIT-08FJX-08FJX-142
25	3	616040	04CIT-06FJX-06FJX-67	68	1	618183	3/4MJIC-90-7/8MOR LBO
26	3	616028	04CIT-06FJX-06FJX-47	69	2	618314	3/4MJIC UNION
27	1	616057	08CIT-08FJX-08FJX-88	70	1	618562	9/16MOR-90-1/4MNPT LBO
28	2	614664	10CIT-10FJX-10FJX-98	71	1	610447	HYD FILTER, INLINE 1/4FNPT 90M
29	1	712440	1/2 NPT X 3/4 HOSE BARB	72	5	618618	9/16MJIC-90-9/16FJIC SMIV LBO
30	1	503600	CLOSE NIPPLE .50NPT	73	4	618338	9/16MJIC-45-1/4MNPT LBO
31	2	618531	9/16FJIC CAP NUT	74	2	610450	RESTRICTOR .025 1-WAY, 1/2FNPT
32	4	618092	1 1/16MOR-1/2FNPT ADPTR	75	4	618633	1/2MNPT-90-1/4MNPT REDU LBO
33	8	618107	9/16MJIC-90-1/2MNPT LBO	76	2	620632	ACCUMULATOR CYL ASSY 96
34	1	611204	04CIT-06FJX-06FJX-78	77	1	616037	04CIT-06FJX-06FJX-29
35	4	614663	04CIT-06FJX-06FJX-16	78	1	614713	04CIT-06FJX-06FJX-24
36	2	615616	04CIT-06FJX-06FJX-65	79	1	614712	04CIT-06FJX-06FJX-20
37	3	616026	04CIT-06FJX-06FJX-37	80	1	616049	04CIT-06FJX-06FJX-26
38	1	615465	08CIT-08FJX-08FJX-33	81	1	614714	04CIT-06FJX-06FJX-34
39	1	614662	08CIT-08FJX-08FJX-72	82	1	614715	04CIT-06FJX-06FJX-43
40	3	614693	06CIT-06FJX-06FJX-168	83	1	616059	04CIT-06FJX-06FJX-33
41	1	614571	06CIT-06FJX-06FJX-126	84	1	618609	3/4MJIC-90-3/4FJIC SMIV LBO
42	2	611208	04CIT-06FJX-06FJX-98	85	2	610675	RESTRICTOR, .042 1-WAY, 1/2FNPT
43	1	618440	9/16MJIC-90-9/16MOR EX LG LBO				

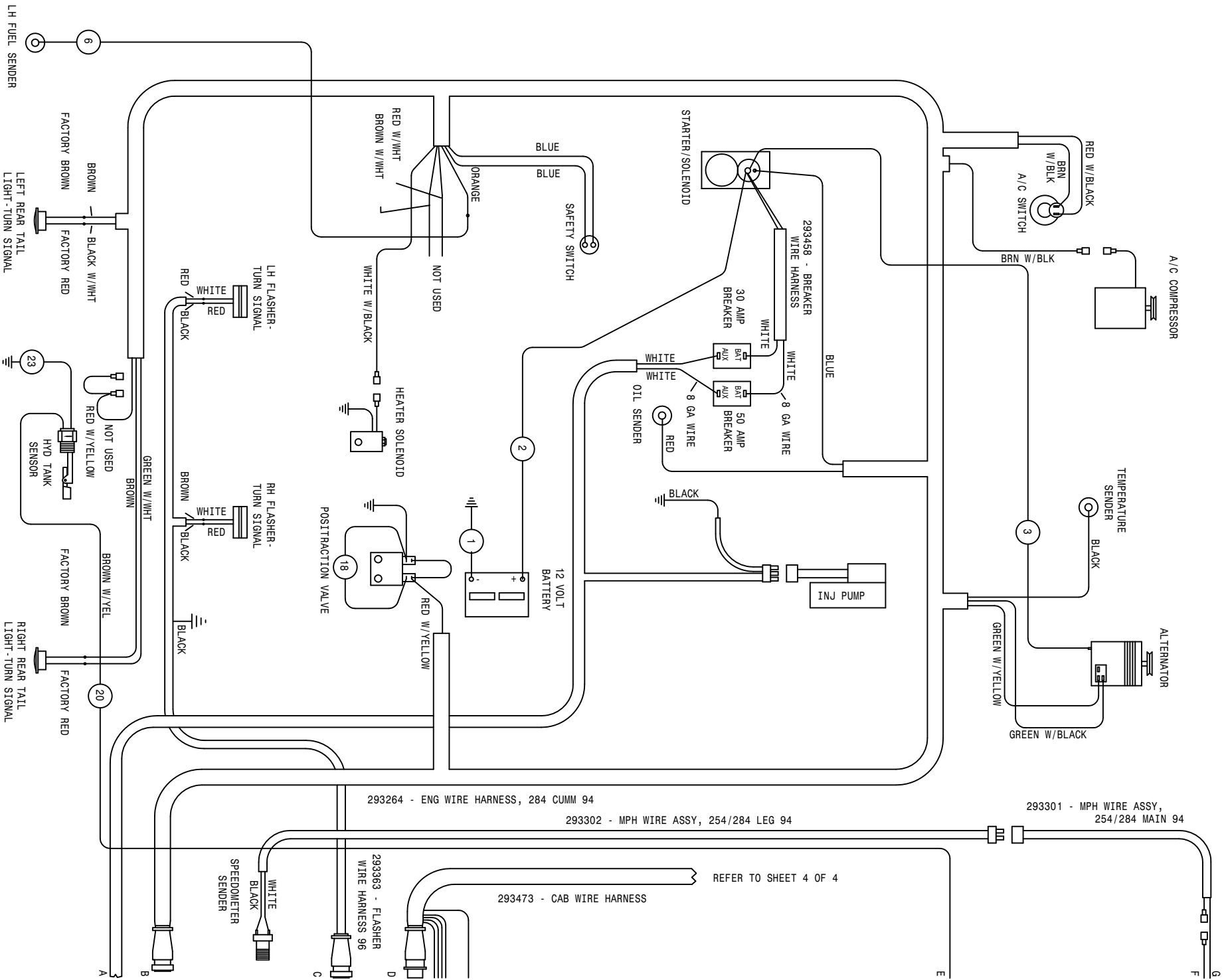

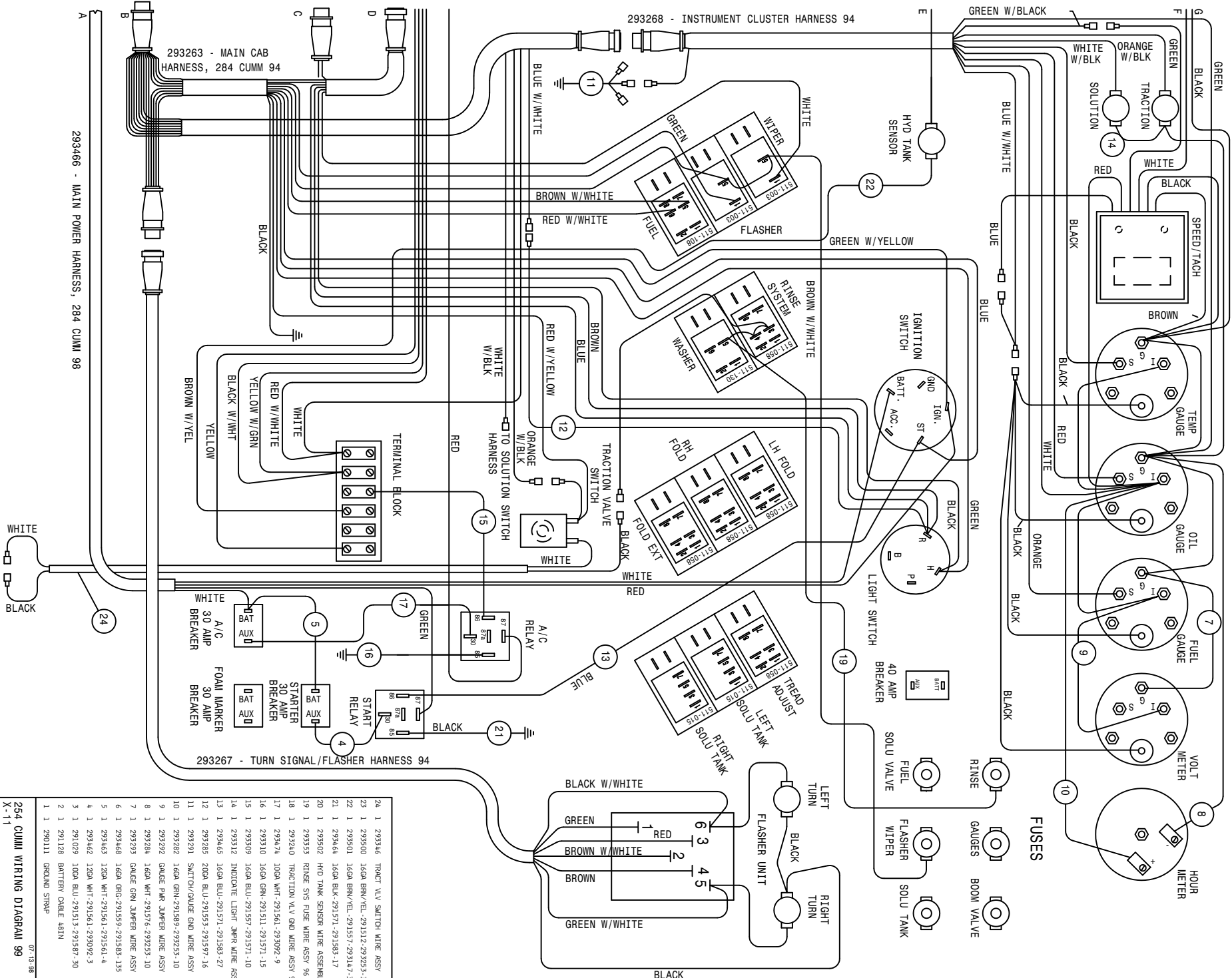

24	1	293346	TRACT VLV SWITCH WIRE ASSY
23	1	293500	16GA BRN/YEL-291512-29253-16
22	1	293501	16GA BRN/YEL-291517-29147-35
21	1	293464	16GA BLK-291571-291589-17
20	1	293502	HVO TANK SENSOR WIRE ASSEMBLY
19	1	293533	RINSE SYS FUSE WIRE ASSY 96
18	1	293240	TRACTION VLV GND WIRE ASSY 92
17	1	293474	10GA WHT-291561-292092-9
16	1	293510	16GA GRN-291511-291571-15
15	1	293509	16GA BLU-291557-291571-10
14	1	293512	INDICATE LHTF JMPR WIRE ASSY
13	1	293465	16GA BLU-291571-291589-27
12	1	293285	20GA BLU-291553-291597-16
11	1	293291	SWITCH/GAUGE GND WIRE ASSY
10	1	293282	16GA GRN-291589-29253-10
9	1	293292	GAUGE PWR JUMPER WIRE ASSY
8	1	293284	16GA WHT-291576-29253-10
7	1	293293	GAUGE GRN JUMPER WIRE ASSY
6	1	293468	16GA ORG-291559-291589-135
5	1	293463	12GA WHT-291561-291561-4
4	1	293462	12GA WHT-291561-293092-3
3	1	291029	10GA BLU-291513-291587-30
2	1	291128	BATTERY CABLE A81N
1	1	290111	GROUND STRAP

254 CUMM WIRING DIAGRAM 99
 X-11
 SHEET 1 OF 4
 REVISION DATE: 06-21-02
 498559

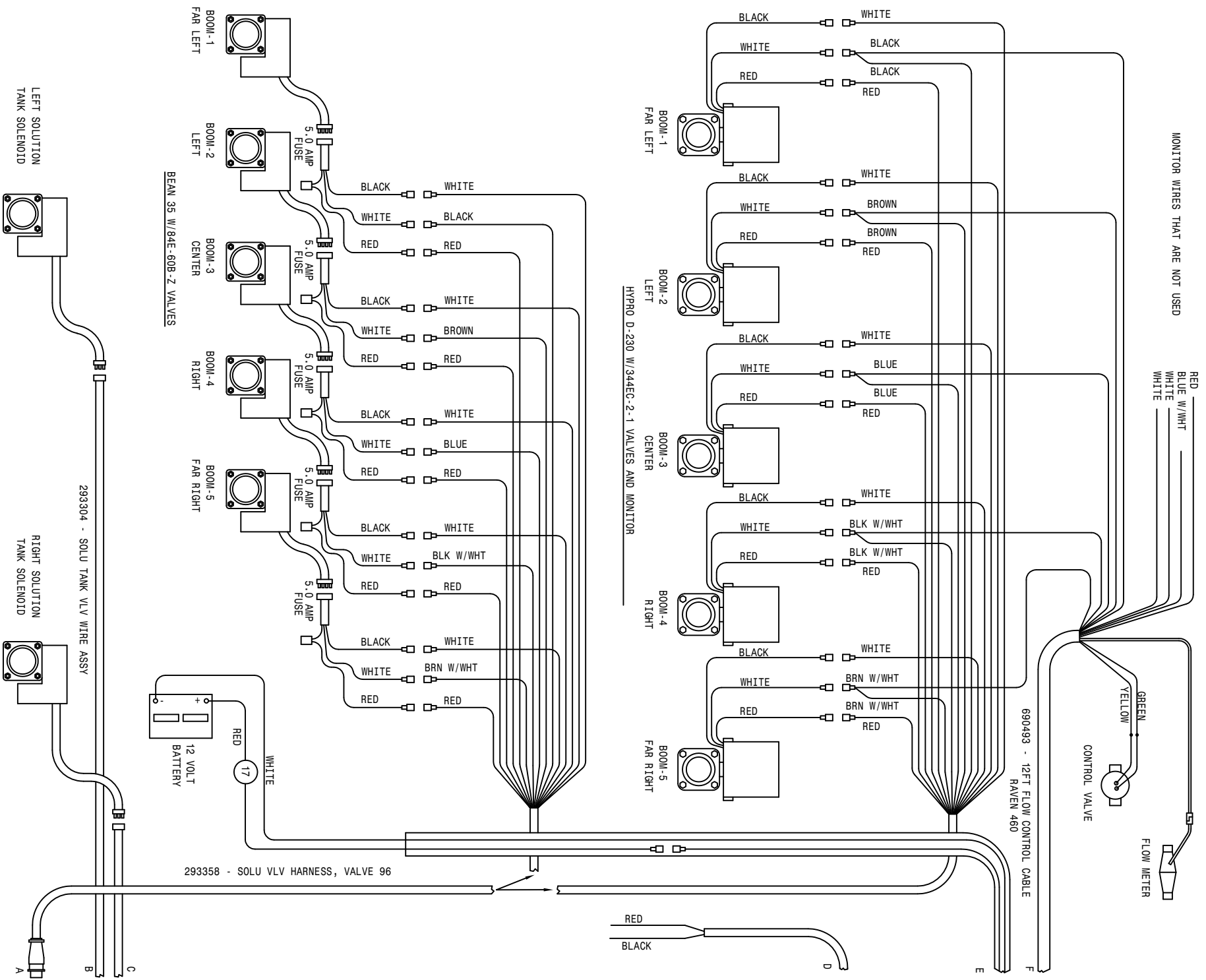

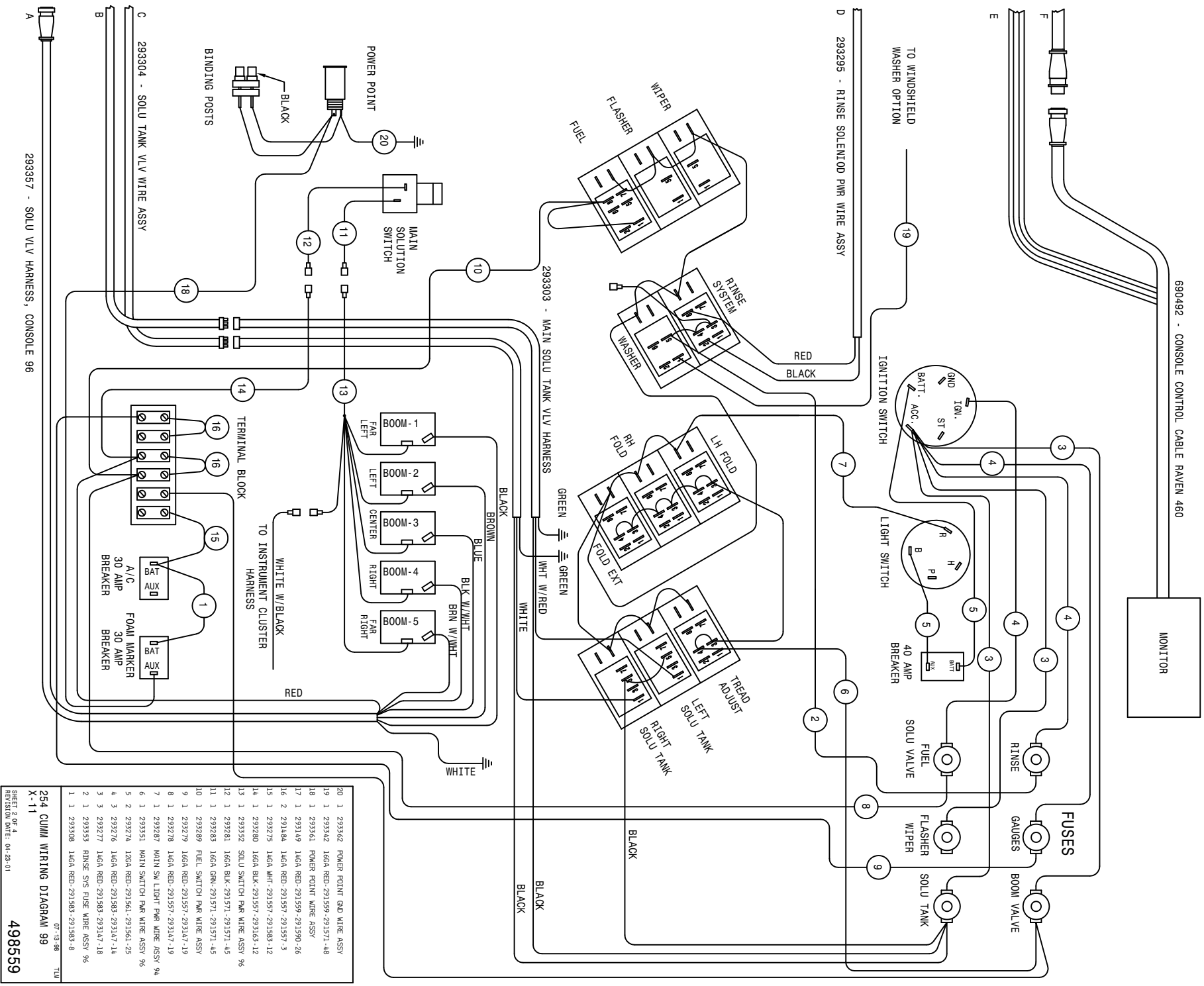

20	1	293362	POWER POINT GND WIRE ASSY
19	1	293342	16GA RED, 291599, 291571, 48
18	1	293361	POWER POINT WIRE ASSY
17	1	293349	16GA RED, 291599, 291570, 26
16	2	293348	16GA RED, 291597, 291573, 3
15	1	293275	16GA WHT, 291597, 291583, 12
14	1	293280	16GA BLK, 291597, 291633, 12
13	1	293352	SOLU SWITCH PWR WIRE ASSY 96
12	1	293281	16GA BLK, 291571, 291571, 45
11	1	293283	16GA GRN, 291571, 291571, 45
10	1	293289	FUEL SWITCH PWR WIRE ASSY
9	1	293279	16GA RED, 291597, 293147, 19
8	1	293278	16GA RED, 291597, 293147, 19
7	1	293287	MAIN SW LIGHT PWR WIRE ASSY 94
6	1	293251	MAIN SWITCH PWR WIRE ASSY 96
5	2	293276	12GA RED, 291561, 291561, 25
4	3	293276	16GA RED, 291583, 293147, 14
3	3	293277	16GA RED, 291583, 293147, 18
2	1	293353	RINSE SVS FUSE WIRE ASSY 96
1	1	293308	16GA RED, 291583, 291583, 8

254 CUIMI WIRING DIAGRAM 99
 X-11
 SHEET 2 OF 4
 REVISION DATE: 04-23-01
 498559
 07-13-88
 TUD

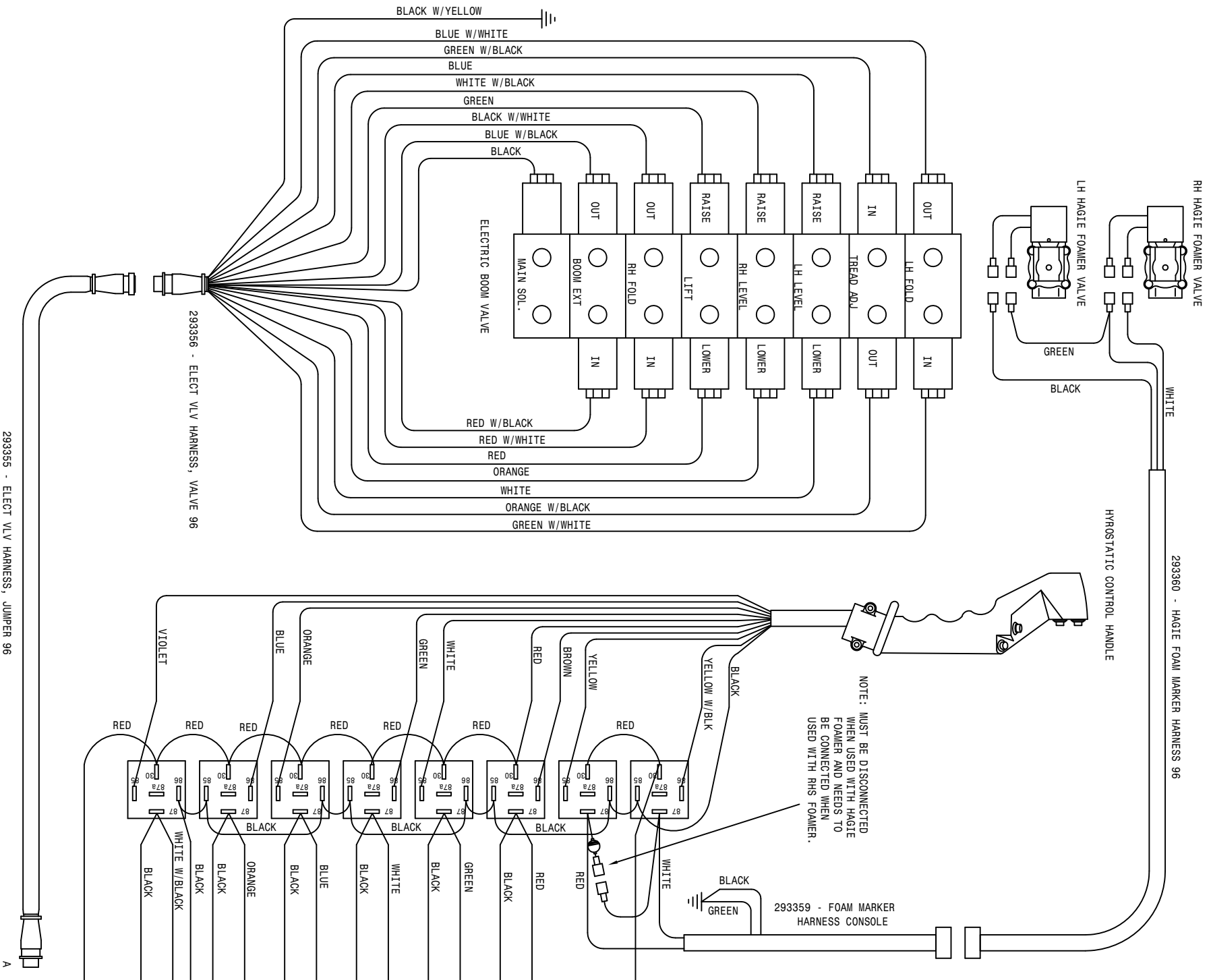

293355 - ELECT VLV HARNESS, JUMPER 96

A

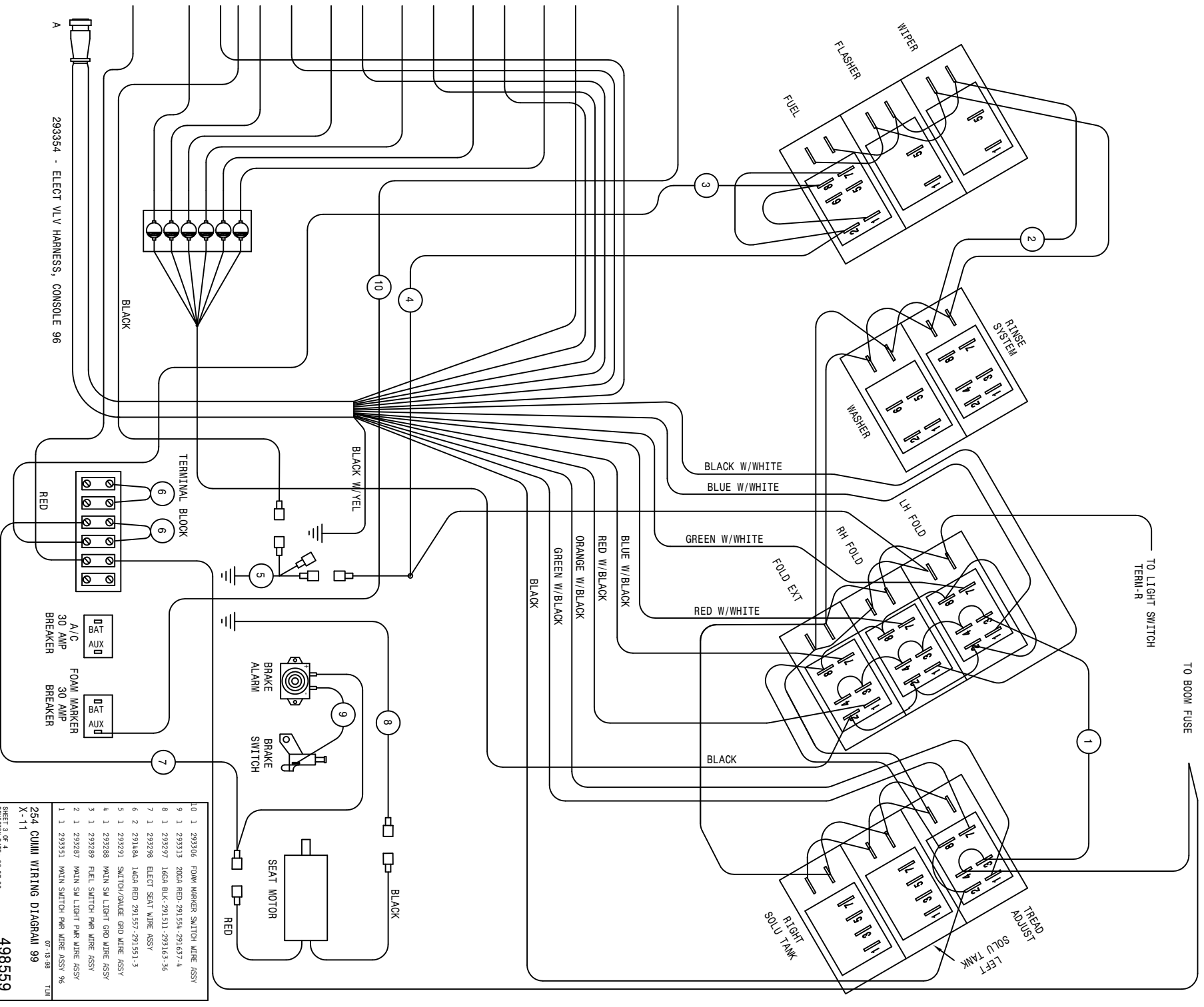

293354 - ELECT VLV HARNESS, CONSOLE 96

BLACK

TERMINAL BLOCK

RED

A/C
AUX
30 AMP
BREAKER

FOAM MARKER
BAT
AUX
30 AMP
BREAKER

BRAKE
ALARM

BRAKE
SWITCH

SEAT MOTOR

TO LIGHT SWITCH
TERM-R

TO BOOM FUSE

TREAD
ADJUST
SOLU TANK

LEFT
SOLU TANK

RIGHT
SOLU TANK

10	1	293306	FOAM MARKER SWITCH WIRE ASSY
9	1	293313	20GA RED 29154-29167-4
8	1	293297	16GA BLK-291511-293163-36
7	1	293298	ELECT SEAT WIRE ASSY
6	2	291484	16GA RED 29157-291511-3
5	1	293291	SWITCH/QUEUE GRD WIRE ASSY
4	1	293288	MAIN SM LIGHT GRD WIRE ASSY
3	1	293289	FUEL SWITCH PWR WIRE ASSY
2	1	293287	MAIN SM LIGHT PWR WIRE ASSY
1	1	293351	MAIN SWITCH PWR WIRE ASSY 96

254 CUMM WIRING DIAGRAM 99

X-11

SHEET 3 OF 4
REVISION DATE: 06/07/98

498559

TLM 07-13-98

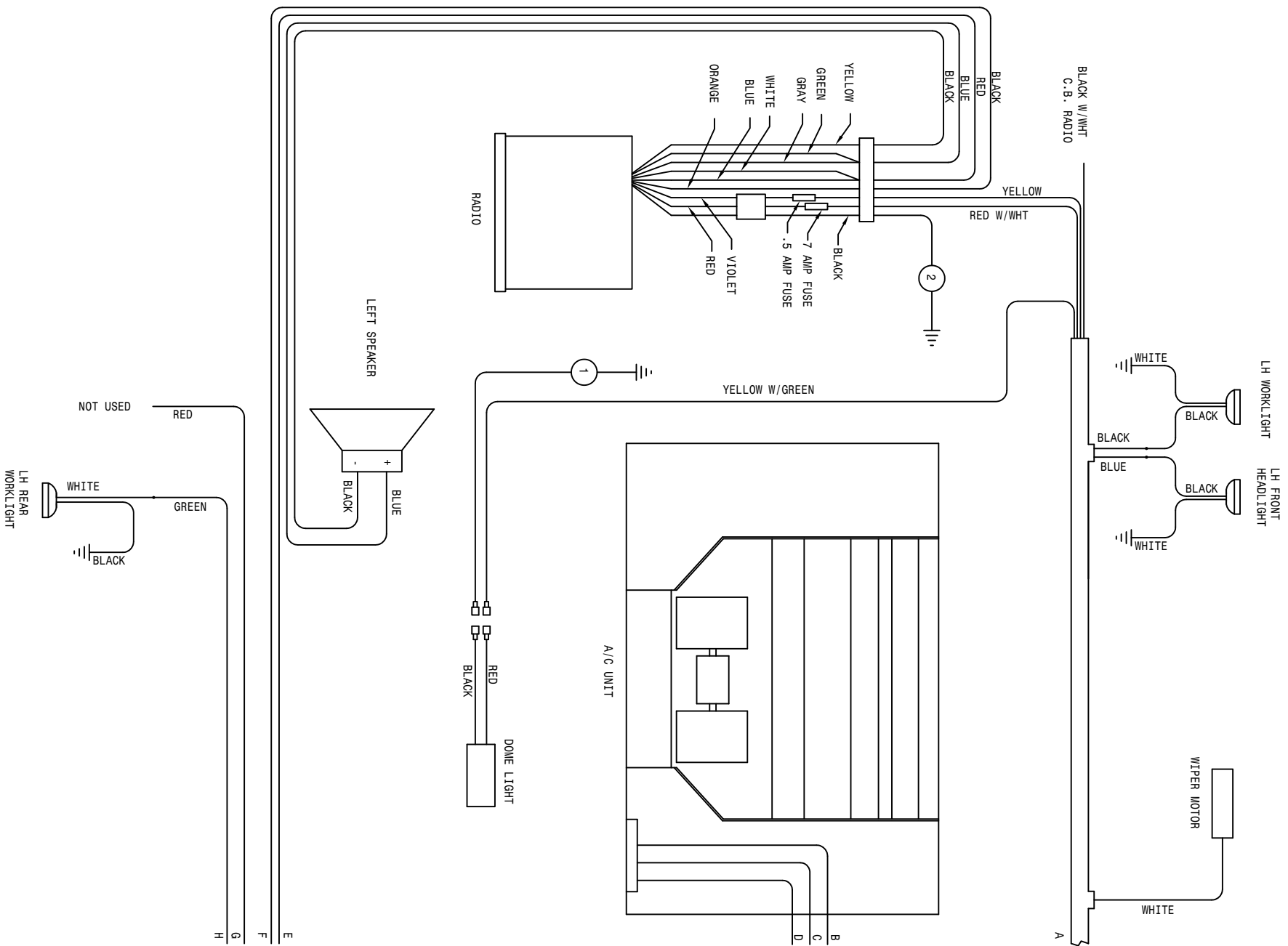

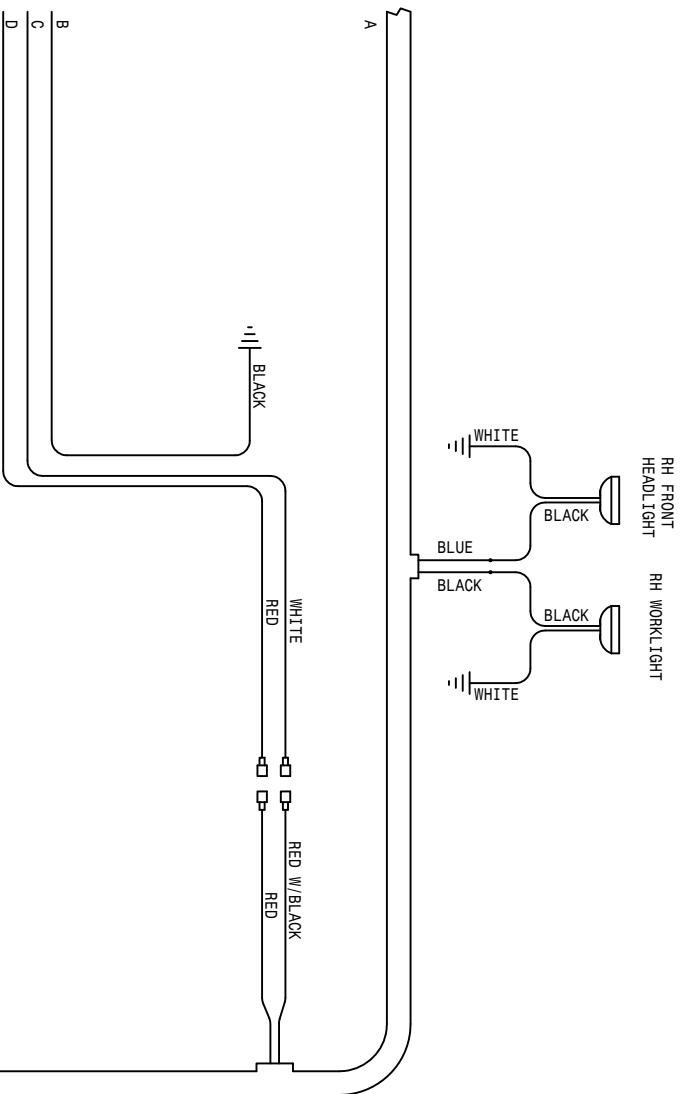

293473 - CAB WIRE HARNESS

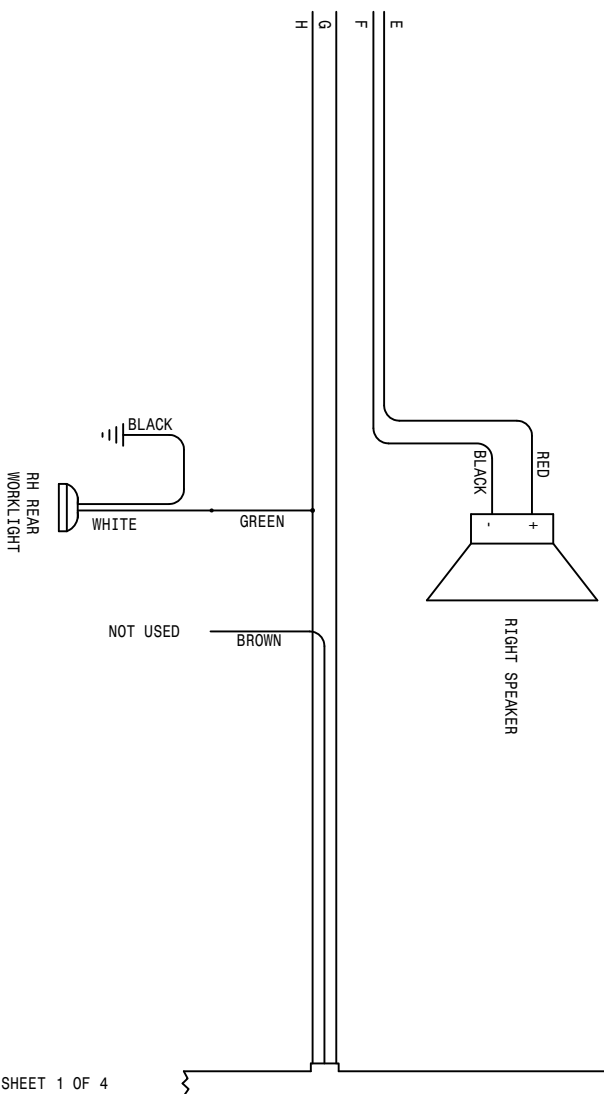

REFER TO SHEET 1 OF 4

2	1	293300	16GA BLK-291511-291571-18
1	1	292999	16GA BLK-291511-291571-30
254 CUMM WIRING DIAGRAM 99			
SHEET 4 OF 4			
X-11			
REVISION DATE:			
498559			

ABBREVIATIONS

A/C - AIR CONDITIONER	MT - MOUNT
ADPTR - ADAPTER	MTR - MOTOR
AGI - AGITATOR	P/N - PART NUMBER
ALT - ALTERNATOR	PLT - PLATE
ASSY - ASSEMBLY	QTY - QUANTITY
BRKT - BRACKET	RED - REDUCER
DET - DETAIL	REF - REFERENCE
DISPL - DISPLACEMENT	REST - RESTRICTOR
EL - ELBOW	REQ - REQUIRED
EXT - EXTENSION	SHFT - SHAFT
FLO - FLOW	SOL - SOLUTION
FNPT - FEMALE NATIONAL PIPE THREAD	STRG - STEERING
FOR - FEMALE O-RING	ST - STREET
FRT - FRONT	SWIV - SWIVEL
HYD - HYDRAULIC	UNC - UNIFIED NATIONAL COURSE
HYDRO - HYDROSTATIC	UNF - UNIFIED NATIONAL FINE
LG - LONG	V - VOLT
LWR - LOWER	W/ - WITH
MJIC - MALE J.I.C.	WHL - WHEEL
MOR - MALE O-RING	WLD - WELDMENT

-A-

ABBREVIATIONS.....84
 ACCUMULATOR CYLINDER.....48
 AGITATOR.....55
 COUPLER.....55
 IMPELLER.....55
 SHAFT.....55
 SHIELD.....55
 AIR CLEANER.....14
 BAND.....14
 CLAMP.....14
 FILTER.....14
 HOOD.....14
 HOSE.....14
 AIR CONDITINER

BELT.....12
 BLOWER.....28
 COMPRESSOR.....12
 CONDENSER.....12
 DRYER.....12
 FILTER.....28
 AIR INTAKE.....13
 SCREEN.....13
 ANTENNA.....28
 ARM,
 STEERING.....16
 STEERING PIVOT.....20
 WIPER.....26

-B-

BAND,
 AIR CLEANER.....14
 FUEL TANK.....24
 BASKET, STRAINER.....56
 BATTERY.....45
 BOX.....45
 CABLE.....45
 HOLDDOWN.....45
 BEAN 35 PUMP.....63
 BELT.....5, 12
 BINARY SWITCH.....12
 BLADE, WIPER.....26
 BLOCK, TERMINAL.....33
 BRAKE
 CABLE.....17, 36
 CABLE EXTENSION.....36
 CLIP RETAINER.....17
 DISC.....17
 LEVER.....36
 MOUNT.....17
 PAD.....17

BREAKAWAY.....47
 BREAKER, CIRCUIT.....33
 BREATHER.....25
 BOOM.....52, 53
 CRADLE.....43
 VALVE.....61, 64
 BUZZER.....36

-C-

CAB.....26
 ROOF.....26
 CABLE,
 BATTERY.....45
 BRAKE.....17, 36
 CAP,
 FUEL.....24
 RADIATOR.....13
 STEERING WHEEL.....30
 CATWALK.....56, 57
 CIRCUIT BREAKER.....33
 COMPRESSOR.....12
 MOUNT.....12
 CONDENSOR COIL.....12
 CONSOLE.....33
 COOLER, OIL.....13
 CRADLE, TANK.....56, 57
 CROP GUIDE.....16, 19
 CROSSMEMBER, FRONT.....22
 CYLINDER,
 ACCUMULATOR.....48
 FOLD.....47, 50
 LEVEL.....47, 51
 LIFT.....46, 49
 STEERING.....21

-D-

DECALS.....70
 DIFFUSER, LINE.....25
 DIMMER SWITCH.....26
 DIPSTICK.....25
 DISC,
 BRAKE.....17
 FRICTION.....35
 SENSOR.....17
 DOOR.....27
 HANDLE.....27
 LATCH.....27
 DRAIN COCK.....13
 DRYER, AIR CONDITIONER.....12
 DRINK HOLDER.....33
 DRIVE ASSEMBLY.....4
 DROP ASSEMBLY, 6FT.....66, 67

-E-

ELECTRICAL SCHEMATIC.....76
ENGINE.....4,5
EXHAUST PIPE.....15
EXTENSION,
BRAKE CABLE.....36

-F-

FAN
BLADE.....5
SPACER.....5
FILTER,
AIR CLEANER.....14
AIR CONDITIONER.....28
FUEL.....4,5,25
MICHIGAN.....25
OIL.....5,11
FLASHER LIGHT.....43
FLOW DIVIDER.....9
FLUSHING VALVE.....10
FOAM.....29
FOLD CYLINDER.....47,50
FRICTION DISC.....35
FUEL
CAP.....24
GAUGE.....31
SELECTOR VALVE.....24
SENDER.....24
TANK.....24
FUSE.....32
HOLDER.....32

-G-

GAS SPRING.....27
GAUGE,
FUEL.....31
OIL PRESSURE.....31
PRESSURE.....61,64
TEMPERATURE.....31
VOLT METER.....31
GEAR PUMP.....6
GLASS.....26,27
GRAB HANDLE.....26
GROMMET, RUBBER.....26
GROUND STRAP.....4,26,45
GUIDE, CROP.....16,19

-H-

HANDLE,
DOOR.....27
GRAB.....26

HANDRAIL.....40

HEADLAMP SWITCH.....32
HEADLIGHT.....26
HEATER SOLENOID.....23
HEAT SHIELD.....15
HOLDER,
DRINK.....33
FUSE.....32

HOOD,
AIR CLEANER.....14

ENGINE.....38
HOOK, RUBBER.....40,41
HOSE,
AIR CLEANER.....14

FUEL.....24
RADIATOR.....5
HOUR METER.....31
HUB, TORQUE.....16,17,68
HYDROSTATIC
LEVER.....34
PUMP.....6

HYDRAULIC
SCHEMATIC.....72
TUBE.....17,46
HYPRO 230 PUMP.....60

-I-

IGNITION SWITCH.....32
IMPELLER, AGITATOR.....55
INDICATOR, MPH/RPM.....31
INJECTION PLATFORM.....59
INNER TUBE.....18
INTERIOR LIGHT.....28

-K-

KICK PANEL.....26
KIT,
LIGHT.....31
SEAL.....21,49,50,51
KNOB,.....30,35
SWITCH.....32

-L-

LADDER.....42
LATCH, DOOR.....27
LEG,
FRONT.....16
HYDRAULIC TUBE.....17
REAR.....17

LEVEL CYLINDER.....47, 51
 LEVEL,
 BRAKE.....36
 HYDROSTATIC.....34
 THROTTLE.....35
 LIFTARM.....46
 LIFT CYLINDER.....46, 49
 LIGHT,
 FLASHER.....26
 INTERIOR.....28
 KIT.....31

-M-

MANIFOLD,
 BEAN 35.....63
 HYPRO D230.....61
 METAL, SHEET.....40, 41
 METER, HOUR.....31
 MIRROR.....26
 MOTOR
 MOUNT.....4, 5
 STEERING.....30
 WIPER.....26
 MOUNT,
 BRAKE.....17
 FUEL TANK.....24
 MONITOR.....33
 RUBBER.....4, 5
 THROTTLE CABLE.....4
 MUFFLER.....15

-O-

OIL
 COOLER.....13
 FILTER.....5, 6, 11
 PRESSURE GAUGE.....31
 SENDER.....4
 TANK.....25

-P-

PACKING, GLAND.....55
 PAD, BRAKE.....17
 PANEL, KICK.....26
 PIVOT PIN.....22
 PLATFORM, INJECTION.....59
 PRESSURE GAUGE.....61, 64
 PUMP,
 HYDROSTATIC.....6
 HYPRO D230.....60

-R-

RADIATOR.....13

CAP.....13
 DRAIN COCK.....13
 HOSE.....5
 SHROUD.....13
 RADIO.....28
 RECOVERY TANK.....13
 RELAY.....33, 34
 RELIEF VALVE.....9
 RIM.....18
 ROOF, CAB.....26
 RUBBER
 GROMMET.....26
 HOOK.....40, 41
 MOUNT.....4, 26

-S-

SCHEMATIC,
 ELECTRICAL.....76
 HYDRAULIC.....72
 SCREEN, AIR INTAKE.....13
 SEAL KIT.....21, 49, 50, 51
 SEAT.....37
 SENDER,
 FUEL.....24
 OIL.....4
 TEMPERATURE.....5
 SENSOR,
 DISC.....17
 SPEEDOMETER.....17
 SERVICE PLATFORM.....42
 SHAFT,
 AGITATOR.....55
 SHEET METAL.....40, 41
 SHIELD,
 AGITATOR.....55
 HEAT.....15
 TANK.....44
 WHEEL MOTOR.....17
 SHROUD, RADIATOR.....13
 SIGHT GAUGE.....56, 57
 SMV SIGN.....41
 SOLENOID, HEATER.....23
 SOLUTION,
 TANK.....56, 57
 VALVE.....56, 57
 SPACER,
 BATTERY BOX.....45
 FAN.....5
 SPEAKER.....28
 SPRING, GAS.....27
 STEERING
 ARM.....16
 CYLINDER.....21
 MOTOR.....30

PIVOT ARM.....20
 POST.....30
 WHEEL.....30
 STRAINER, BASKET.....56
 STRAP, GROUND.....4, 26, 45
 SWITCH,
 BINARY.....12
 DIMMER.....26
 HEADLAMP.....32
 IGNITION.....32
 PARK BRAKE.....36
 TOGGLE.....32

-T-

TAILLIGHT.....41, 59
 TANK
 CRADLE.....56, 57
 FUEL.....24
 OIL.....25
 RECOVERY.....13
 SHIELD.....44
 SOLUTION.....56, 57
 TEMPERATURE
 GAUGE.....31
 SENDER.....5
 TERMINAL BLOCK.....33
 THROTTLE
 CABLE MT.....4
 LEVER.....35
 TIE PLATE.....44
 TIE ROD.....20
 TIRE.....18
 TOGGLE SWITCH.....32
 TORQUE HUB.....16, 17, 68
 TRACTION VALVE.....7, 8
 TRANSOM.....47
 TUBE, INNER.....18

-V-

VALVE,
 BOOM.....61, 64
 FUEL SELECTOR.....24
 FLUSHING.....10
 RELIEF.....9
 SOLUTION.....56, 57
 TRACTION.....7, 8
 VFC.....39
 VOLTMETER.....4

WHEEL MOTOR.....16, 17
 SHIELD.....17
 WHEEL, STEERING.....30
 WIPER.....26
 ARM.....26
 BLADE.....26
 MOTOR.....26

-W-



PARTS ORDER FAX

Fax
24 hours
a day
7 days
a week**

Ph. 1 (800) 247-4885 Fx. 1 (515) 532-3553

Photocopy and fax to Hagie Customer Support Department

ORDERED BY/BILL TO:

Name _____
Co. Name _____
Street _____
City, St, Zip _____
Ph. _____ Fx. _____

SHIP TO:

Name _____
Co. Name _____
Street _____
City, St, Zip _____
Ph. _____ Fx. _____

HOW SHIP: UPS Ground Next Day 2 Day 3 Day Other _____

If "HOW SHIP" is left blank, parts will be sent UPS ground service. If part is over 150 pounds, an independent motor freight company will be used.

PAYMENT: Hagie Account #*** _____

C.O.D

American Express Discover Visa Master Card

Signature: _____
name as appears on card: _____
card no. _____ exp. date _____

Year and Model No. _____

Serial No. _____

Item Serial No. (if necessary): _____

Engine (include type) _____

Hydrostatic Pump (s) _____

Torque Hub _____ LF RF LR RR

Wheel Motor _____ LF RF LR RR

HAGIE Part No.	Qty.	Description

Check here if you want phone confirmation of parts order.

* Orders received before 3:00 p.m., CST will be processed the same business day.

Regular business hours are Monday through Friday, 7:00 a.m. through 5:00 p.m..

** If you do not have a Hagie account number, contact the Hagie Customer Support Department and you will be issued one.



PARTS ORDER FAX

Fax
24 hours
a day
7 days
a week™

Ph. 1 (800) 247-4885

Fx. 1 (515) 532-3553

Photocopy and fax to Hagie Customer Support Department

ORDERED BY/BILL TO:

Name _____
Co. Name _____
Street _____
City, St, Zip _____
Ph. _____ Fx. _____

SHIP TO:

Name _____
Co. Name _____
Street _____
City, St, Zip _____
Ph. _____ Fx. _____

HOW SHIP: UPS Ground Next Day 2 Day 3 Day Other _____

If "HOW SHIP" is left blank, parts will be sent UPS ground service. If part is over 150 pounds, an independent motor freight company will be used.

PAYMENT: Hagie Account #*** _____

C.O.D

American Express Discover Visa Master Card
Signature: _____
name as appears on card: _____
card no. _____ exp. date _____

Year and Model No. _____

Serial No. _____

Item Serial No. (if necessary): _____

Engine (include type) _____

Hydrostatic Pump (s) _____

Torque Hub _____ LF RF LR RR

Wheel Motor _____ LF RF LR RR

HAGIE Part No.	Qty.	Description

Check here if you want phone confirmation of parts order.

* Orders received before 3:00 p.m., CST will be processed the same business day.

Regular business hours are Monday through Friday, 7:00 a.m. through 5:00 p.m..

** If you do not have a Hagie account number, contact the Hagie Customer Support Department and you will be issued one.