

**PARTS MANUAL**  
**FOR**  
**HAGIE MODEL 284 TXP HI-TRACTOR**

**HAGIE MANUFACTURING COMPANY**

BOX 273 CLARION, IOWA 50525 (515) 532-2861

COVERS MACHINE SERIAL NUMBERS: U1220440001 thru U1220440100

12-03 493300  
02-08

SPRAYER IDENTIFICATION

Each Hagie sprayer is identified by means of a frame serial number. This serial number denotes the model, the year in which it was built, and the number of the sprayer. As for further identification, the engine has a serial number and the planetary hubs have identification plates that describe the type of mount and gear ratio. To insure prompt, efficient service when ordering parts or requesting service repairs from Hagie Manufacturing Company, record the serial and identification numbers in the space provided below.

NOTE: Reference to left hand and right hand used throughout this manual refers to the position when seated in the operator's seat facing forward.

SPRAYER SERIAL NUMBER

\_\_\_\_\_

ENGINE SERIAL NUMBER

\_\_\_\_\_

PLANETARY HUB IDENTIFICATION NUMBERS

\_\_\_\_\_

TABLE OF CONTENTS

ENGINE ASSEMBLIES . . . . . 4-6

FLOW DIVIDER . . . . . 7

AIR TANK ASSEMBLY. . . . . 8-9

FLUSHING VALVE. . . . . 10-11

A/C AND RADIATOR. . . . . 12-13

AIR CLEANER AND EXHAUST PIPE. . . . . 14

HYDRAULIC TUBING . . . . . 15

HYDRAULIC TANK . . . . . 16

LEG ASSEMBLIES. . . . . 17-25

STEERING CYLINDER . . . . . 26

BATTERY . . . . . 27

CAB ASSEMBLY. . . . . 28-32

INSTRUMENT PANEL ASSEMBLY . . . . . 33

SWITCH PANEL ASSEMBLY . . . . . 34

CONSOLE ASSEMBLY. . . . . 35-37

SEAT AND MONITOR . . . . . 38-39

WINDSHIELD WASHER . . . . . 40

SELECTOR VALVE AND VFC. . . . . 41-42

BOOM CRADLE . . . . . 43

SHEET METAL . . . . . 44-45

LADDER AND FUEL TANK. . . . . 46-47

SERVICE PLATFORM ASSEMBLY . . . . . 48

SOLUTION TANK. . . . . 49-53

SOLUTION SYSTEM . . . . . 54-56

BOOM VALVE. . . . . 57

TRANSOM, BOOM, AND LIFT COMPONENTS. . . . . 58-65

TREAD ADJUSTMENT OPTION. . . . . 66-68

DROP NOZZLE AND HOSES . . . . . 69-70

DECALS. . . . . 72-73

HYDRAULIC SCHEMATIC . . . . . 74-79

ELECTRICAL SCHEMATIC. . . . . 80-89

ABBREVIATIONS . . . . . 90

INDEX . . . . . 91

ENGINE ASSEMBLY

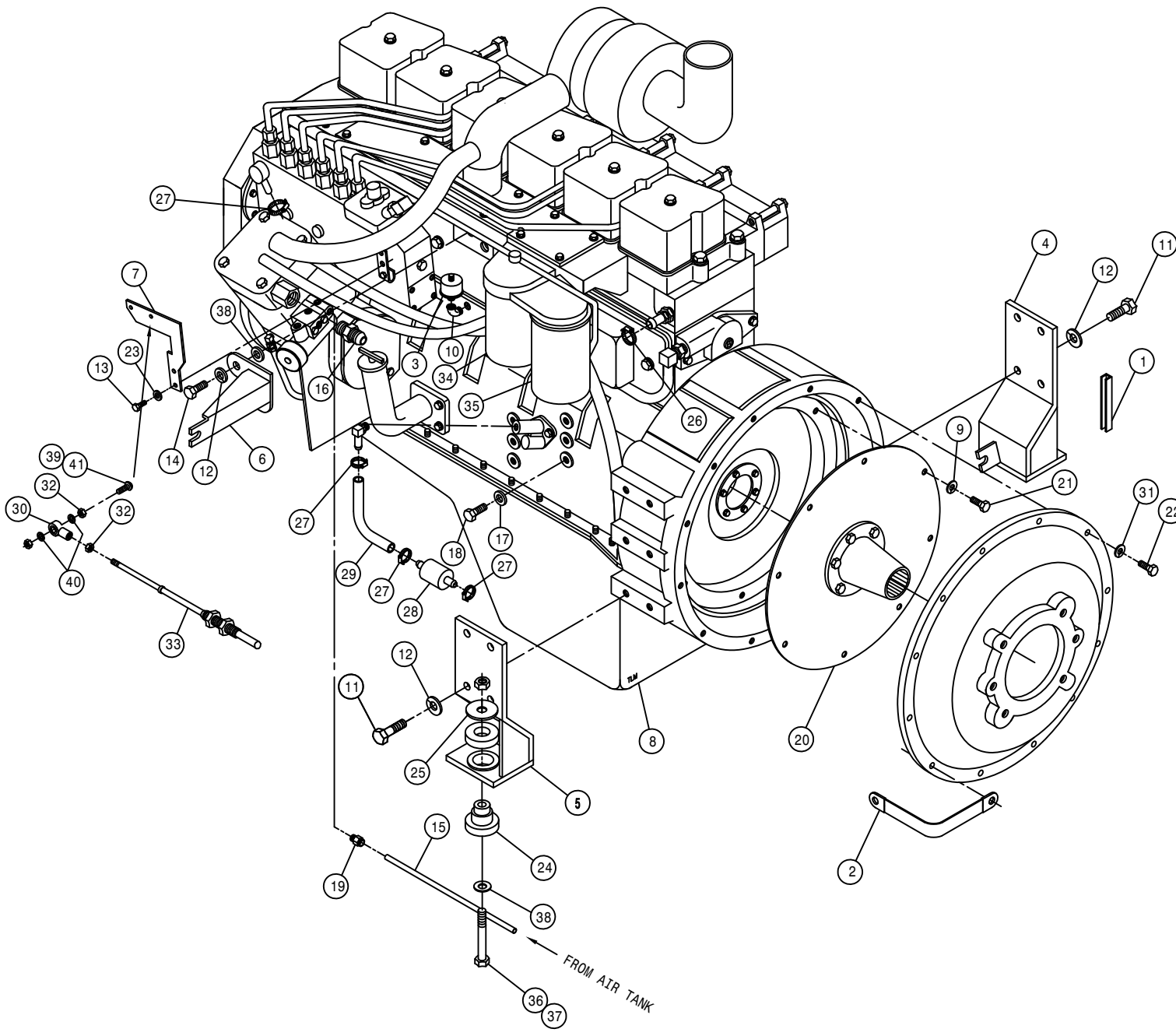

DET.	QTY	PART NO.	DESCRIPTION
	1	193012	QUICKEDGE TRIM .135 TO .250
	2	290107	GROUND CABLE,8" X 4GA .406LUGS
	3	291674	OIL PRESS SENDER,125PSI,1/8NPT
	4	316252	RH REAR ENG MT WLD, CUMM 94
	5	316253	LH REAR ENG MT WLD, CUMM 94
	6	316517	THROTTLE CABLE MT WLD, CUMM 02
	7	316516	THROTTLE CABLE LEVER, CUMM 02
	8	316568	CUMM ENG,6B5.9A 152@2500 CMPSR
	9	920502	3/8 LOCK WASHER
	10	500900	BLK PIPE ST EL 90DEG .125NPT
	11	473775	12MM-1.75 X 30MM HEX BOLT
	12	473784	12MM LOCK WASHER
	13	473826	6MM-1.00 X 16MM HEX BOLT
	14	473828	12MM-1.50 X 20MM HEX BOLT
	15	601619	HOSE, 1/4 X 27 AIR
	16	610300	3/4MJIC-3/4MNPT ADPTR
	17	473804	8MM LOCK WASHER
	18	473827	8MM-1.25 X 20MM HEX BOLT
	19	711036	1/8MNPT-1/4 NYL TUBE FTG
	20	800503	DRIVE DISK ASSY,11.5" 23T SPL
	21	900128	3/8UNC X 3/4 HEX BOLT
	22	473792	10MM-1.50 X 30MM HEX BOLT
	23	473768	6MM LOCK WASHER
	24	311054	RUBBER MOUNT SET, CB-2202-4
	25	311055	REBOUND WASHER FOR 311054
	26	520055	HOSE CLAMP NO 12 STAINLESS
	27	520120	HOSE CLAMP NO 4 STAINLESS
	28	316281	FUEL STRAINER, IN-LINE, DIESEL
	29	601347	HOSE, 3/8 X 10 FUEL LINE
	30	473921	BALL JOINT NO 10-32 THD
	31	473798	10MM LOCK WASHER
	32	910027	10-32 HEX NUT
	33	785066	CTRL CABLE 10-32 4IN X 129 IN
	34	316208	FUEL FILTER, PRIMARY CUMM 92
	35	316209	FUEL FILTER, SECONDARY CUMM92
	36	900271	1/2UNC X 3 1/4 HEX BOLT
	37	914008	1/2UNC HEX STOVER NUT
	38	920004	1/2 SAE FLAT WASHER
	39	914027	10-32 HEX STOVER NUT
	40	920510	#10 LOCK WASHER
	41	903893	10-32 X 1" SLT RD HD MACH SCR

4

ENGINE ASSEMBLY

DET. QTY PART NO. DESCRIPTION

1	1	193012	QUICKEDGE TRIM .135 TO .250
2	1	291197	CIRCUIT BREAKER,30AMP,INLINEMT
3	1	291556	CIRCUIT BREAKER,50AMP,INLINEMT
4	1	314832	RADIATOR HOSE 1.75 X 19(52423)
5	1	314836	TEMP SENDR 280D 1/2NPT FOR GA
6	1	316180	FAN, 22" 6 BLADE 30DEG 2.25PIT
7	1	316199	22IN FAN SPACER CUMM 92
8	1	316250	RH FRT ENG MT WLD, CUMM 94
9	1	316568	CUMM ENG,6B5.9A 152@2500 CMPSR
10	1	316313	LH FRT ENG MT WLD, 284 CUMM 98
11	1	316339	BREAKER MTG PLT, 2100 98
12	1	316340	BREAKER COVER, 2100 98
13	4	470175	10-32 HEX FLANGE LOCK NUT
14	2	470216	10-32 X 3/4 FLANGE HEX BOLT
15	6	473775	12MM-1.75 X 30MM HEX BOLT
16	2	473782	12MM-1.75 X 18MM HEX BOLT
17	8	473784	12MM LOCK WASHER
18	4	473804	8MM LOCK WASHER
19	4	473822	8MM-1.25 X 70MM HEX BOLT
20	2	520067	HOSE CLAMP NO 28 STAINLESS
21	1	618573	5/8 HOSE BARB-90-1/2MNPT
22	4	903812	6-32 X 1/2 SLT RD HD MACH SCR
23	8	910022	6-32 HEX NUT
24	6	910027	10-32 HEX NUT
25	2	311053	RUBBER MOUNT SET,SSB26-1000-1
26	1	314886	RADIATOR HOSE 2 1/4 20717
27	1	470118	1/4UNC X 3/4 FLANGE HEX BOLT
28	1	470121	1/4UNC HEX FLANGE LOCK NUT
29	4	900265	1/2UNC X 1 1/2 HEX BOLT
30	1	520055	HOSE CLAMP NO 12 STAINLESS
31	2	900271	1/2UNC X 3 1/4 HEX BOLT
32	6	914008	1/2UNC HEX STOVER NUT
33	6	920004	1/2 SAE FLAT WASHER
34	1	520126	CUSH HOSE CLAMP 2IN X 5/8W
35	2	520099	HOSE CLAMP NO 40 STAINLESS
36	1	316206	POLY V BELT CUMMINS DIESEL 92
37	1	316207	LUBE FILTER CUMMINS DIESEL 92
38	1	341968	TIE PLT 250/280 CUMM 92
39	1	316367	DELCO ALTERNATOR,130 AMP 22SI
40	1	316216	STARTER FOR CUMM 6 CYL 316185
41	1	291852	RELAY, 40 AMP, VF4 SERIES
42	1	903883	10-32 X 1/2 SLT RDHD MACH SCR

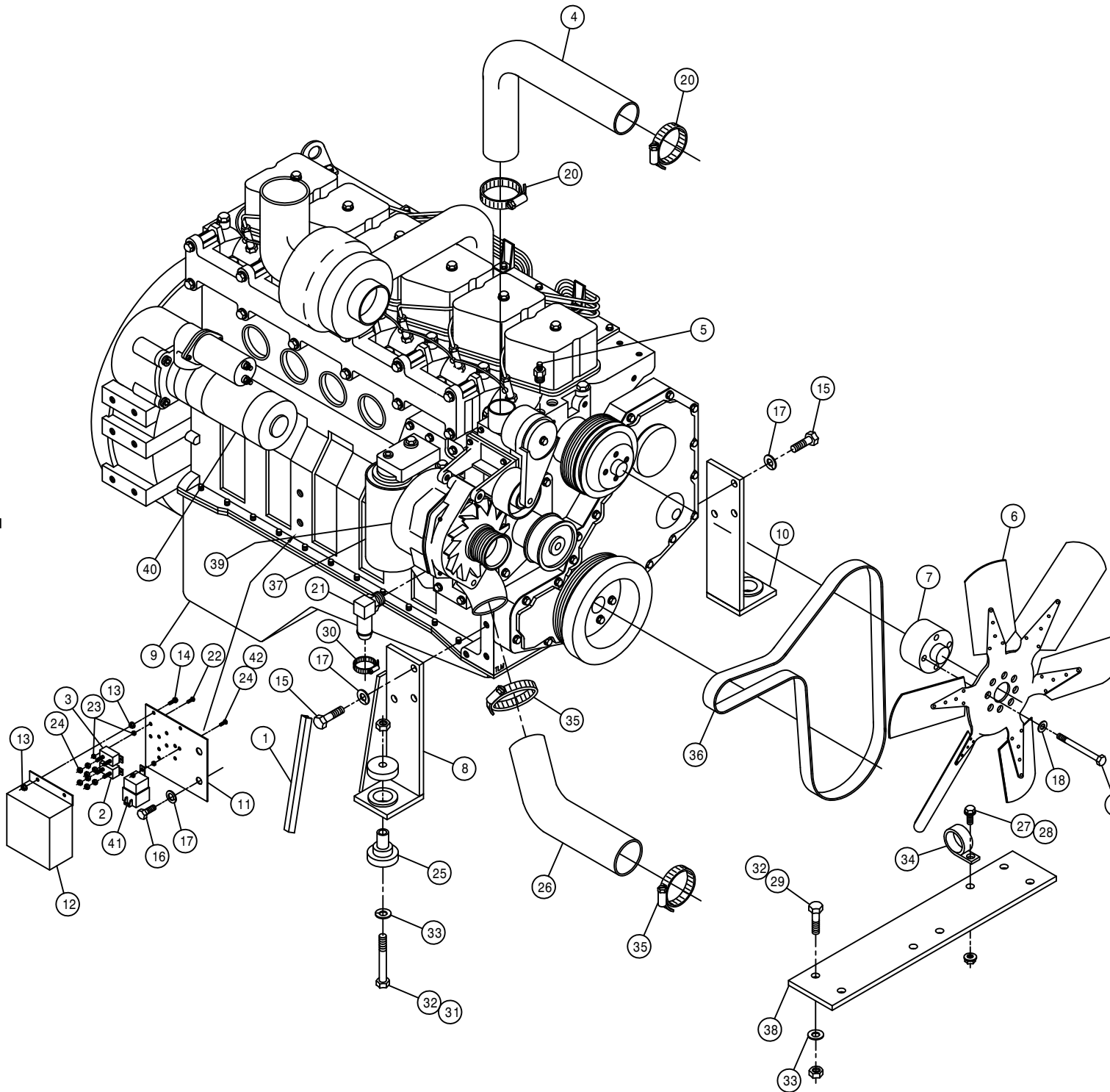

HYDROSTATIC PUMP ASSEMBLY

DET. QTY PART NO. DESCRIPTION

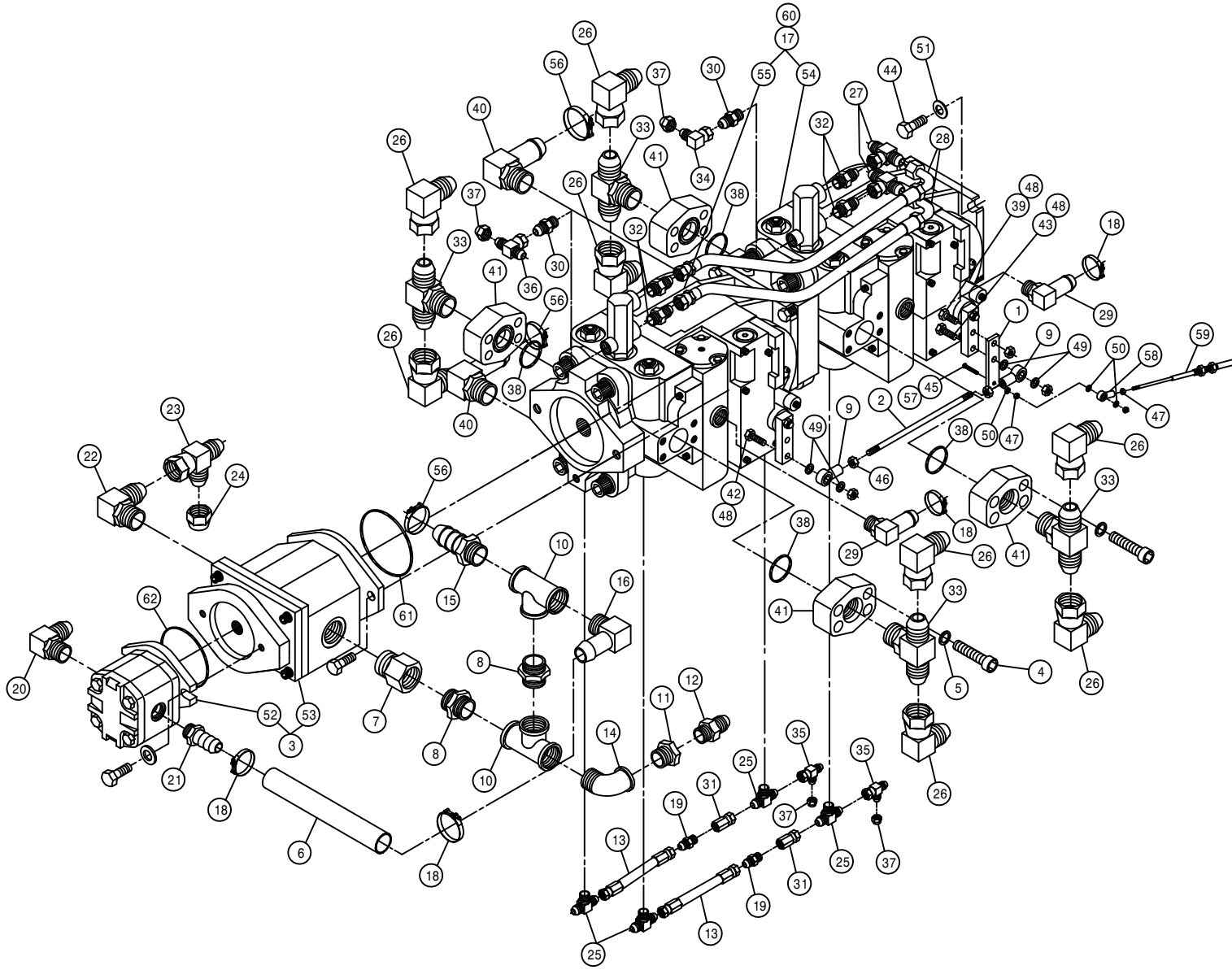

1	1	316160	PUMP CONT LEVER EXT 280 CUMM
2	1	316335	HYDST PUMP CTRL ROD, 2100 98
3	1	606941	TANDEM PUMP, 606929 & 606932
4	16	470188	7/16-14 X 1 3/4 SKTHD CAP SCR
5	16	470189	7/16 HC LOCK WASH FOR 618598
6	1	601399	HOSE, 3/4 X 13 1FBR-1SPI
7	1	618090	1 5/16MOR-1FNPT ADPTR
8	2	505105	1MNPT HEX PIPE NIPPLE STL
9	2	473998	BALL JOINT,1/4-28 1/4BORE
10	2	505101	BLK PIPE TEE 1.00NPT
11	1	505213	RED BUSH 1 X 3/4 BLK MAL
12	1	610300	3/4MJIC-3/4MNPT ADPTR
13	2	615734	04C2AT-06FJX-06FJX-11 H/A
14	1	505200	BLK PIPE ST EL 90DEG 1.00NPT
15	1	714560	1NPT X 1 HOSE BARB
16	1	716000	3/4 HOSE BARB-90-1MNPT
17	1	606943	TANDEM PUMP, 606944 & 606947
18	4	520137	1.12/1.25 T-BOLT HOSE CLAMP
19	2	614740	RESTRICTOR FTG ASSY, .050
20	1	611128	7/8MJIC-90-7/8MOR LBO
21	1	618075	3/4 HOSE BARB-1 1/16MOR
22	1	618535	7/8MJIC-90-1 1/16MOR LBO
23	1	618333	7/8FJIC SW RUN TEE-7/8MJIC
24	1	618328	7/8FJIC CAP NUT
25	4	618629	9/16MOR BRANCH TEE-9/16MJIC
26	8	618640	1 5/16MJ-90-1 5/16FJ SWIV LBO
27	2	618643	3/4FJ SW BRANCH TEE-3/4MJ
28	2	614739	08C1T-08FJX-08FJX90-16 H/A
29	2	618118	3/4 HOSE BARB-90-1 1/16MOR
30	2	618126	9/16MJIC-9/16MOR ADPTR
31	2	618291	9/16FJX-1/4FNPT ADPTR
32	4	618327	3/4MJIC-7/8MOR ADPTR
33	4	618599	1 5/16MOR BRANCH TEE-1 5/16MJ
34	1	618618	9/16MJIC-90-9/16FJIC SWIV LBO
35	2	618486	9/16FJIC SW RUN TEE-9/16MJIC
36	1	618514	9/16FJ SW BRANCH TEE-9/16MJ
37	4	618531	9/16FJIC CAP NUT
38	4	870219	BUNA ORING 1 5/16 X 1 9/16
39	1	900003	1/4UNC X 1" HEX BOLT
40	2	618564	1IN HOSE BARB-90-1 5/16MOR
41	4	618598	1" 4-BOLT FLG X 1 5/16 FOR
42	1	900004	1/4UNC X 1 1/4 HEX BOLT
43	1	900005	1/4UNC X 1 1/2 HEX BOLT
44	4	900265	1/2UNC X 1 1/2 HEX BOLT
45	1	903893	10-32 X 1" SLT RD HD MACH SCR
46	2	910001	1/4UNF HEX NUT
47	2	910027	10-32 HEX NUT
48	3	914000	1/4UNC HEX STOVER NUT
49	4	920500	1/4 LOCK WASHER
50	3	920510	#10 LOCK WASHER
51	4	920004	1/2 SAE FLAT WASHER
52	1	606929	SUND GEAR PUMP .66CI, SPLINED
53	1	606932	SUND GEAR PUMP,1.60CI,SPLINED
54	1	606944	SUND 75CC PUMP,C/C-MT
55	1	606947	SUND 75CC PUMP,C/B-MT
56	3	520138	1.38/1.56 T-BOLT HOSE CLAMP
57	1	914027	10-32 HEX STOVER NUT
58	1	473921	BALL JOINT NO 10-32 THD
59	1	785003	CTRL CABLE 10-32 4IN X 112 LG
60	1	606950	O-RING, SUND 9004100-0480
61	1	606870	O-RING FOR 606865 SUND B-MT
62	1	606924	O-RING FOR SUND A-MT

9

300006

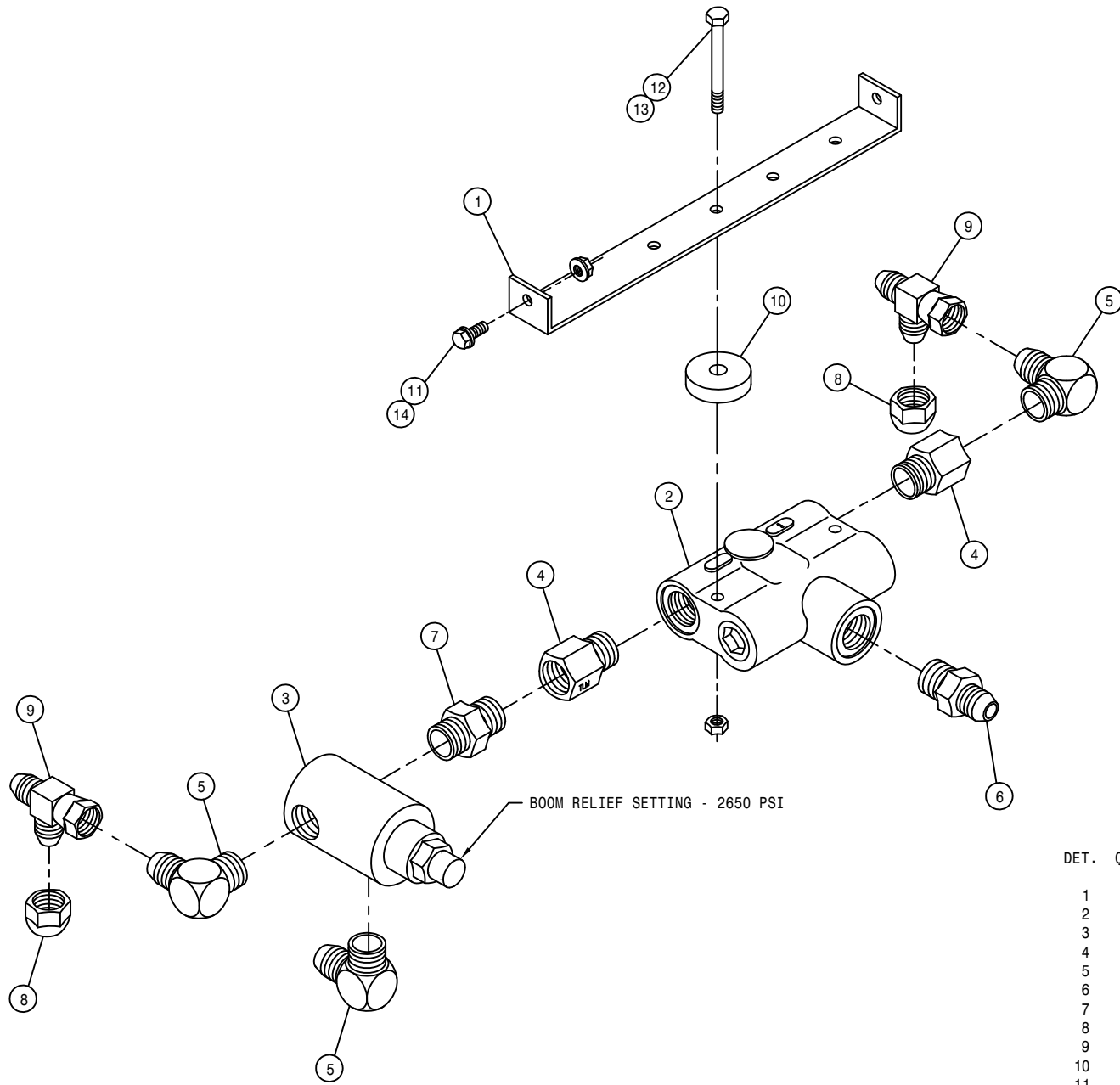

FLOW DIVIDER ASSEMBLY

DET.	QTY	PART NO.	DESCRIPTION	
1	1	341774	FLOW DIVIDER MT 280	89
2	1	610307	FLO DIV BG53 3GPM PRI 7/8FOR	
3	1	607512	RELIEF VALVE, RL50, 1850 PSI	
4	2	618072	7/8MOR-1/2FNPT ADPTR	
5	3	618107	9/16MJIC-90-1/2MNPT LBO	
6	1	611126	7/8MJIC-7/8MOR ADPTR	
7	1	500000	1/2MNPT HEX PIPE NIPPLE STL	
8	2	618531	9/16FJIC CAP NUT	
9	2	618486	9/16FJIC SW RUN TEE-9/16MJIC	
10	2	748500	RUBER WASH 3/8X1/4IDX1 1/2 OD	
11	2	470118	1/4UNC X 3/4 FLANGE HEX BOLT	
12	2	900008	1/4UNC X 2 1/2 HEX BOLT	
13	2	914000	1/4UNC HEX STOVER NUT	
14	2	470121	1/4UNC HEX FLANGE LOCK NUT	

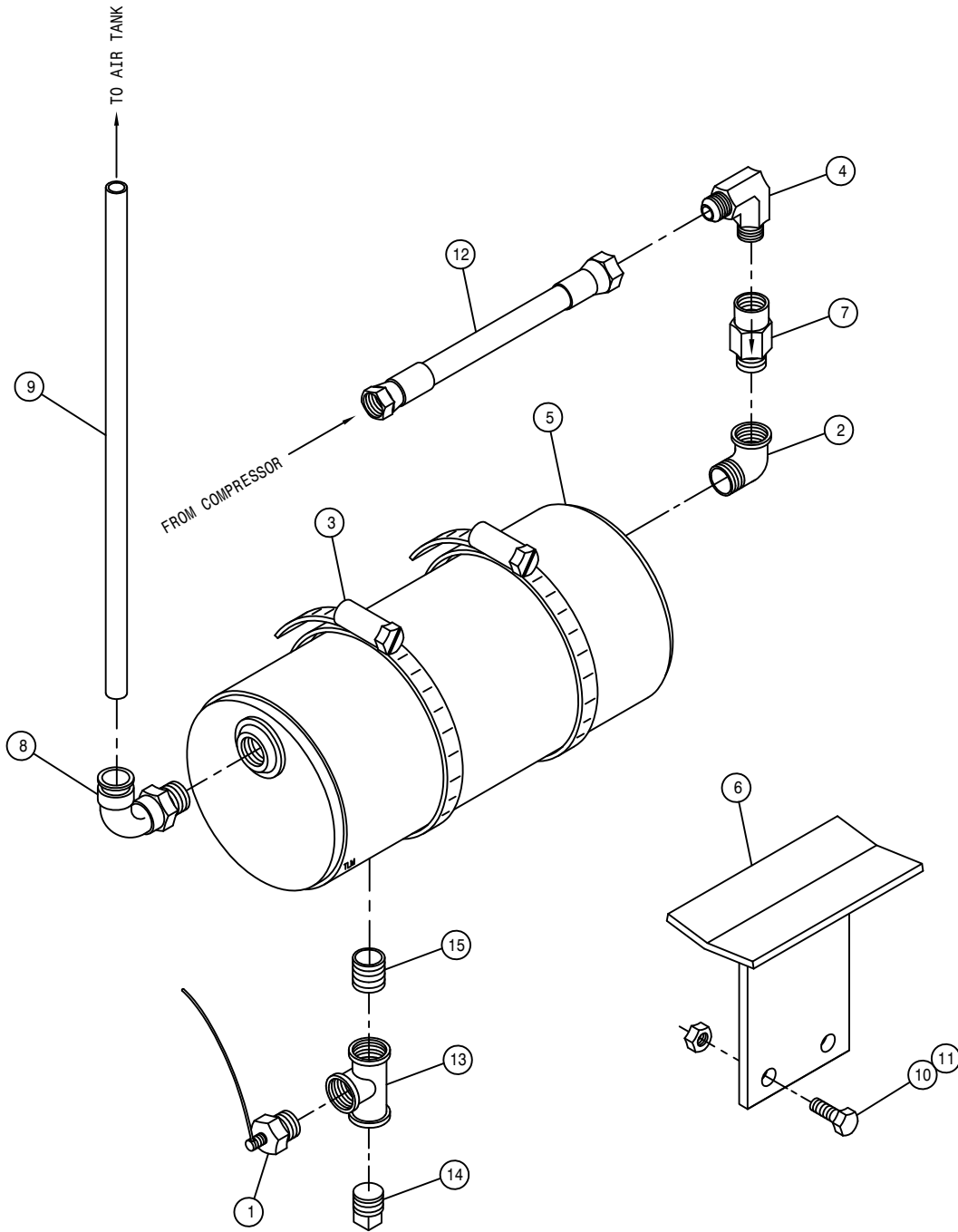

AIR WET TANK ASSEMBLY

DET. QTY PART NO. DESCRIPTION

1	1	470266	DRAIN VALVE KIT, 1/4NPT	
2	1	503400	BLK PIPE ST EL 90DEG .50NPT	
3	2	520086	HOSE CLAMP NO 88 STAINLESS	
4	1	611145	3/4MJIC-90-1/2MNPT LBO	
5	1	701115	WET TANK WLD	98
6	1	701146	WET TANK MTG BRKT WLD, 284	99
7	1	711032	CHECK VALVE, 1/2"FNPT-1/2"MNPT	
8	1	711042	1/2MNPT-1/2 NYL TUBE LBO	
9	1	601441	HOSE, 1/2 X 20 AIR	
10	2	900129	3/8UNC X 1" HEX BOLT	
11	2	914004	3/8UNC HEX STOVER NUT	
12	1	611301	08P919-08FJX-08FJX-18	H/A
13	1	501101	BLK PIPE TEE .25NPT	
14	1	501102	1/4 PIPE PLUG	
15	1	501601	CLOSE NIPPLE .25NPT	



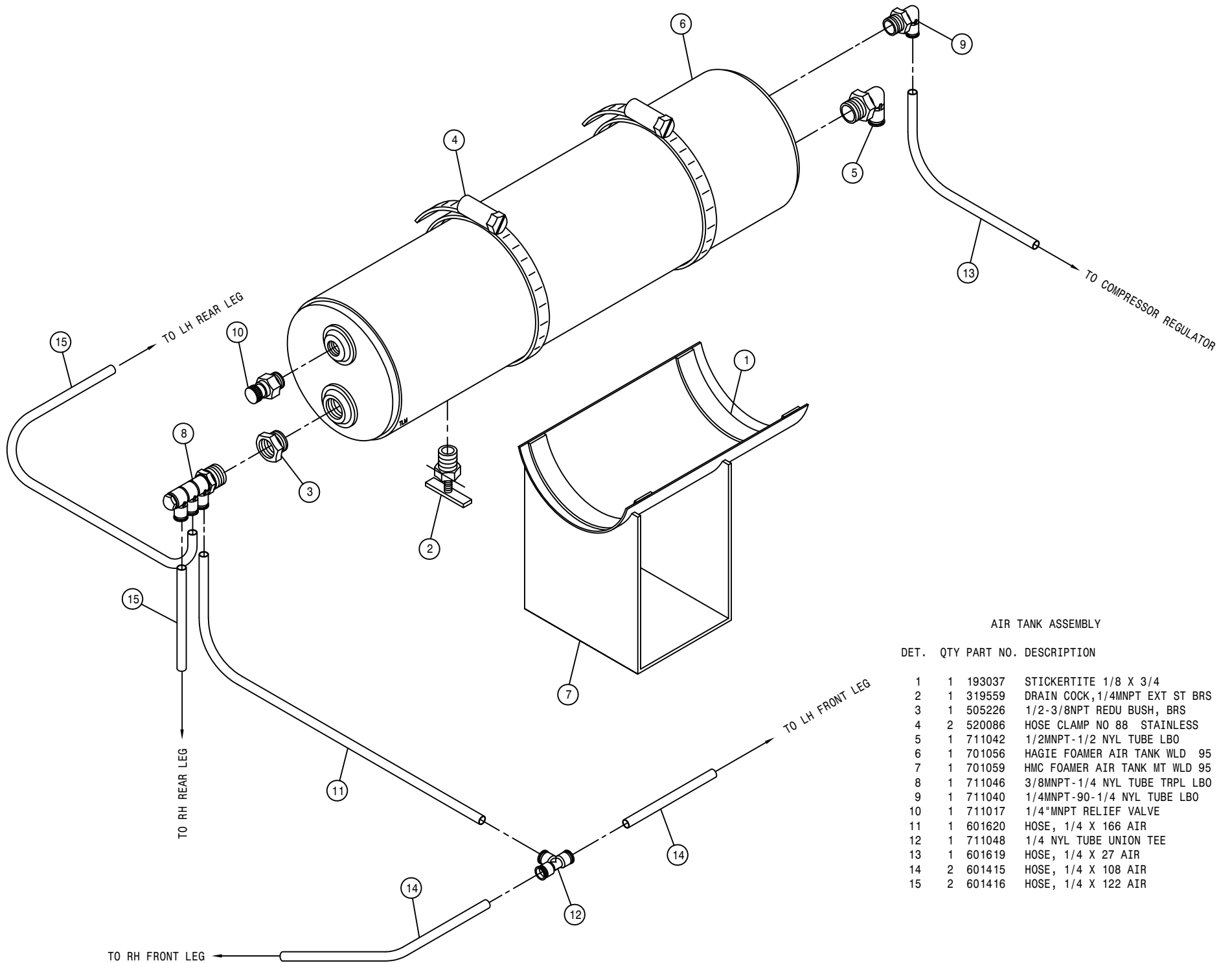

AIR TANK ASSEMBLY

DET.	QTY	PART NO.	DESCRIPTION
1	1	193037	STICKERTITE 1/8 X 3/4
2	1	319559	DRAIN COCK, 1/4MNPT EXT ST BRS
3	1	505226	1/2-3/8NPT REDU BUSH, BRS
4	2	520086	HOSE CLAMP NO 88 STAINLESS
5	1	711042	1/2MNPT-1/2 NYL TUBE LBO
6	1	701056	HAGIE FOAMER AIR TANK WLD 95
7	1	701059	HMC FOAMER AIR TANK MT WLD 95
8	1	711046	3/8MNPT-1/4 NYL TUBE TRPL LBO
9	1	711040	1/4MNPT-90-1/4 NYL TUBE LBO
10	1	711017	1/4"MNPT RELIEF VALVE
11	1	601620	HOSE, 1/4 X 166 AIR
12	1	711048	1/4 NYL TUBE UNION TEE
13	1	601619	HOSE, 1/4 X 27 AIR
14	2	601415	HOSE, 1/4 X 108 AIR
15	2	601416	HOSE, 1/4 X 122 AIR

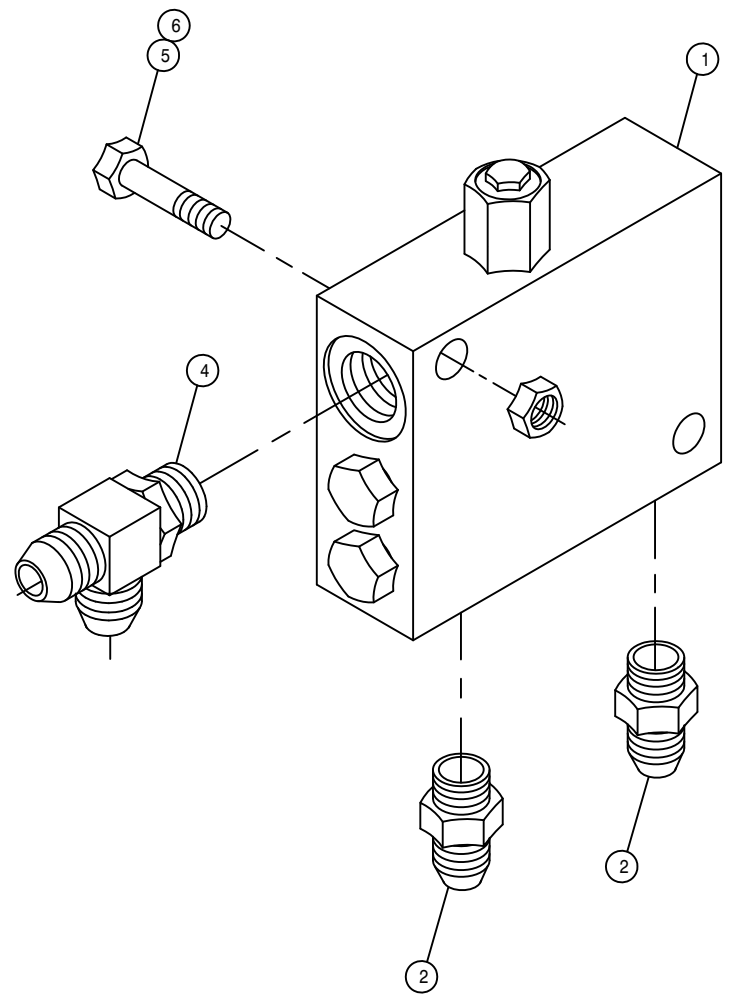
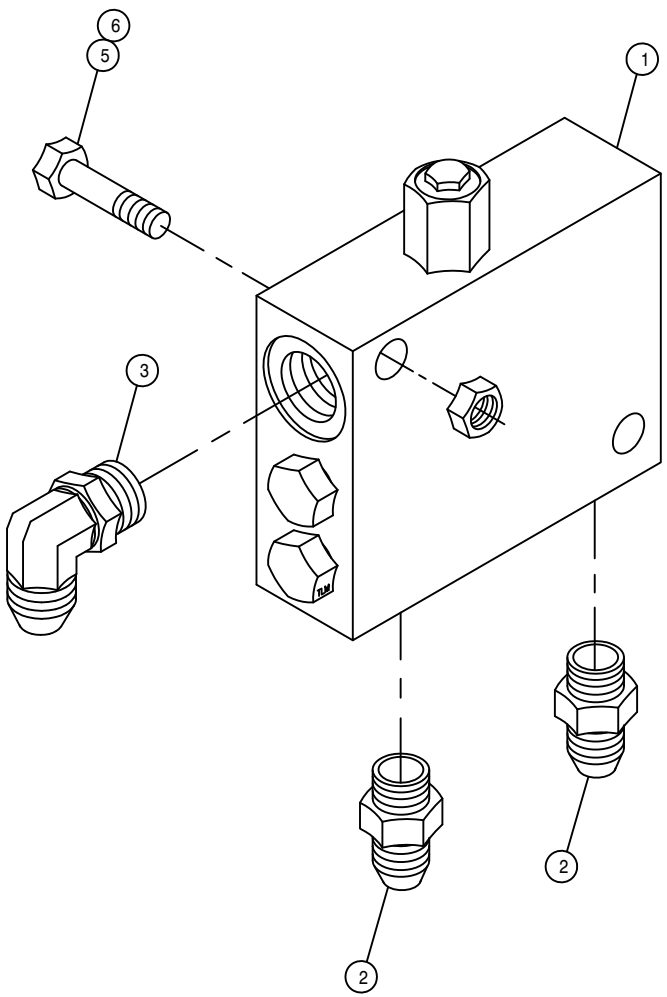

LOOP FLUSHING VALVE ASSEMBLY

DET.	QTY	PART NO.	DESCRIPTION
1	2	610580	REMOTE FLUSHING VALVE, SUND
2	4	618126	9/16MJIC-9/16MOR ADPTR
3	1	618119	9/16MJIC-90-9/16MOR LBO
4	1	618444	9/16MOR RUN TEE-9/16MJIC
5	4	900133	3/8UNC X 2" HEX BOLT
6	4	914004	3/8UNC HEX STOVER NUT

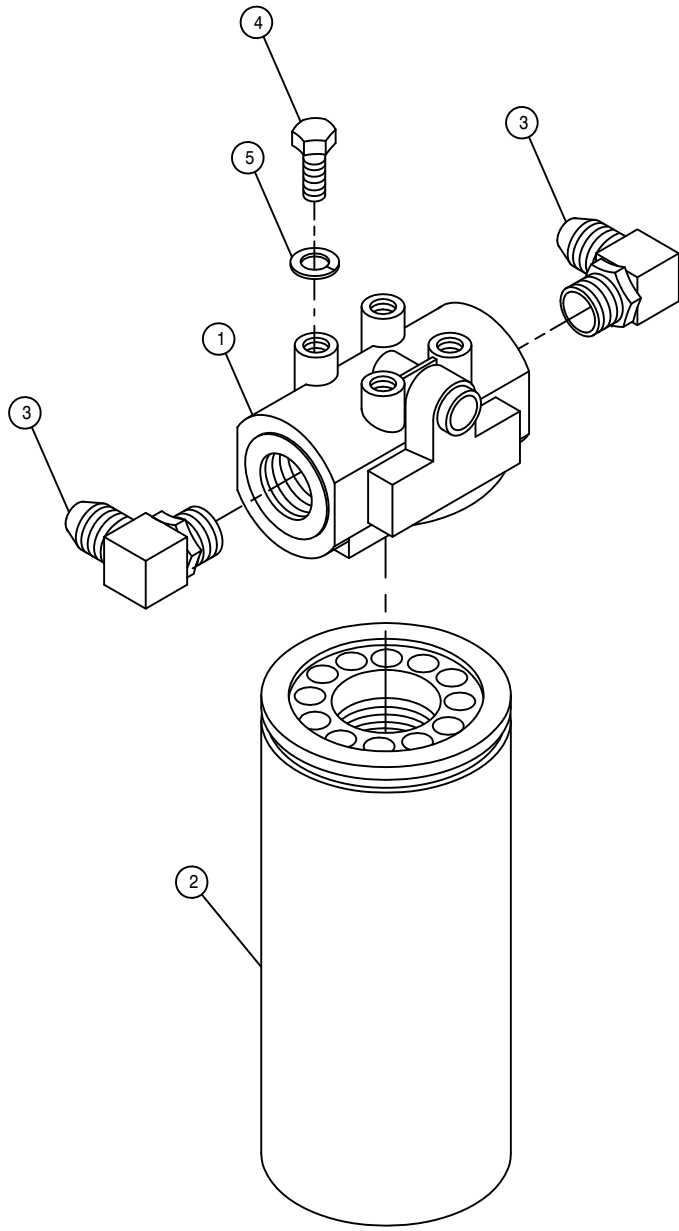

HI-PRESS FILTER ASSEMBLY

DET.	QTY	PART NO.	DESCRIPTION
1	1	605608	HYD FILTER HEAD, DONALDSON
2	1	605609	HYD FILTER ELEMENT, DONALDSON
3	2	618474	3/4MJIC-90-1 1/16MOR LBO
4	4	900128	3/8UNC X 3/4 HEX BOLT
5	4	920502	3/8 LOCK WASHER

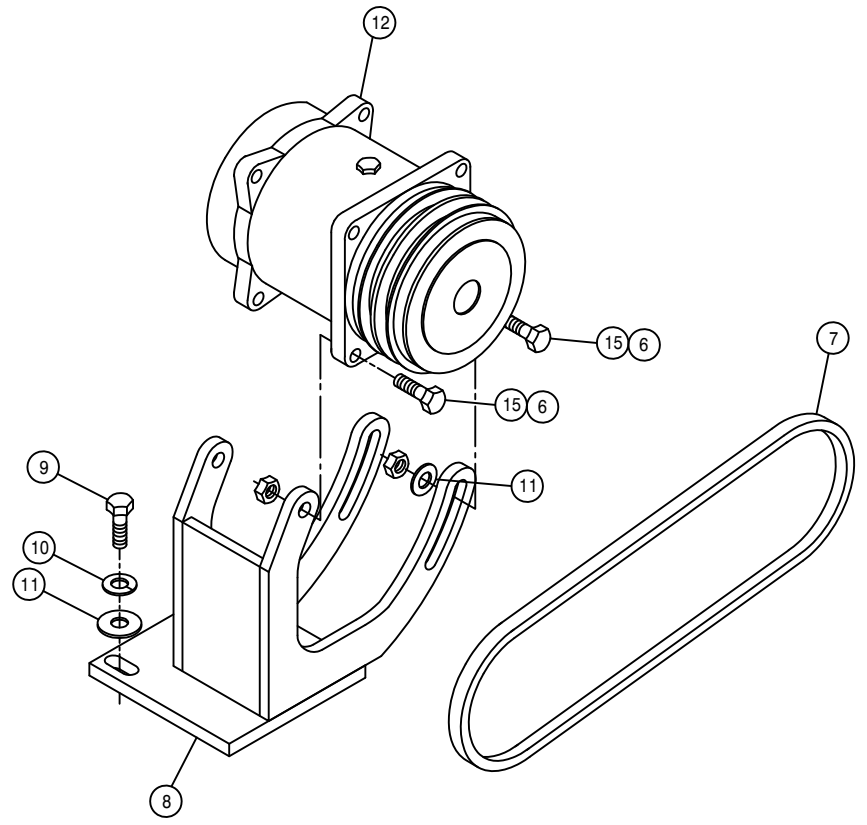
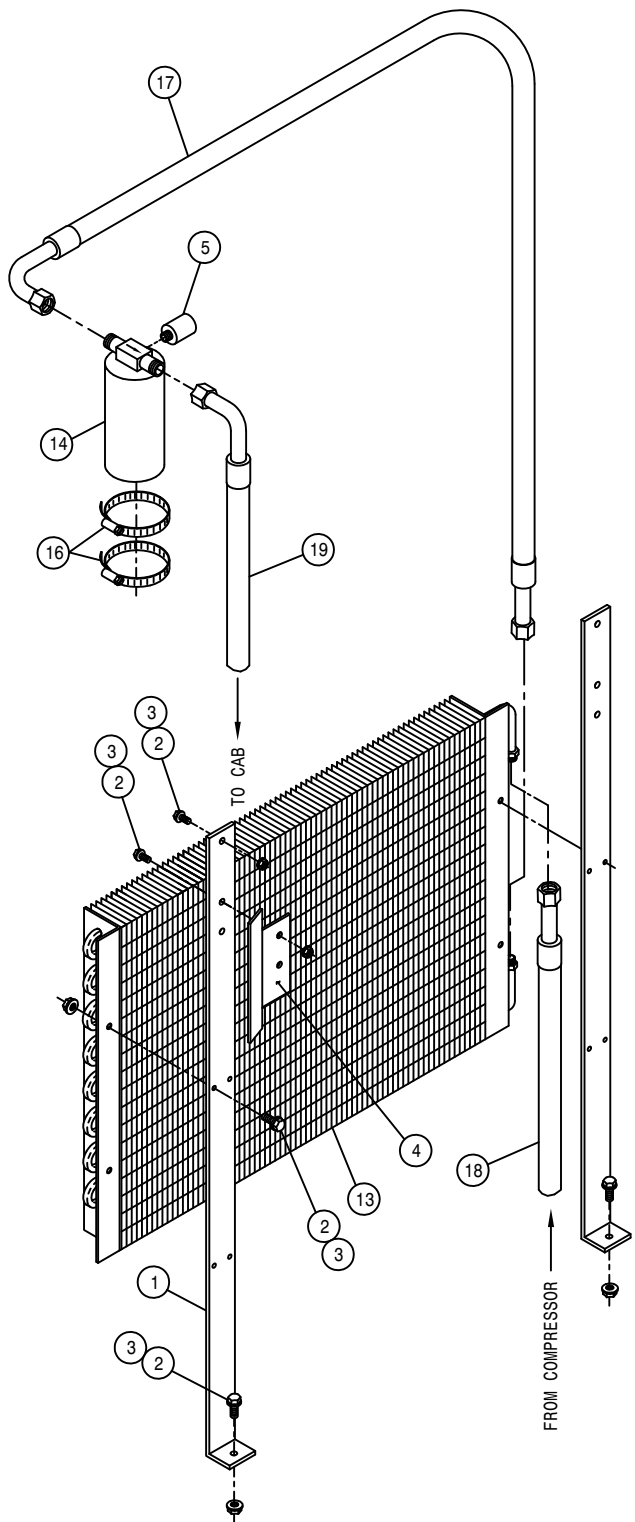

A/C COMPRESSOR PUMP ASSEMBLY

DET.	QTY	PART NO.	DESCRIPTION		
	1	2	315036	CONDENSER MTG BRKT	99
	2	10	470118	1/4UNC X 3/4 FLANGE HEX BOLT	
	3	10	470121	1/4UNC HEX FLANGE LOCK NUT	
	4	1	315038	A/C DRIER MT, 204-254-284	99
	5	1	657422	A/C BINARY SWITCH	
	6	4	914004	3/8UNC HEX STOVER NUT	
	7	1	147050	9455XL BELT, GATES	
	8	1	316314	A/C COMPRSR MT WLD, 284	98
	9	3	473792	10MM-1.50 X 30MM HEX BOLT	
	10	3	473798	10MM LOCK WASHER	
	11	5	483043	3/8 REGULAR FLAT WASHER	
	12	1	657403	A/C COMPRSR, 180D PORTS TM15/12	
	13	1	657423	A/C CONDENSER COIL 21-0324	
	14	1	657421	A/C RECEIVER/DRIER	
	15	4	900131	3/8UNC X 1 1/2 HEX BOLT	
	16	2	520052	HOSE CLAMP NO 52 STAINLESS	
	17	1	657429	A/C HOSE ASSY, 5/16 X 44	
	18	1	657430	A/C HOSE ASSY, 13/32 X 80	
	19	1	657431	A/C HOSE ASSY, 5/16 X 173	

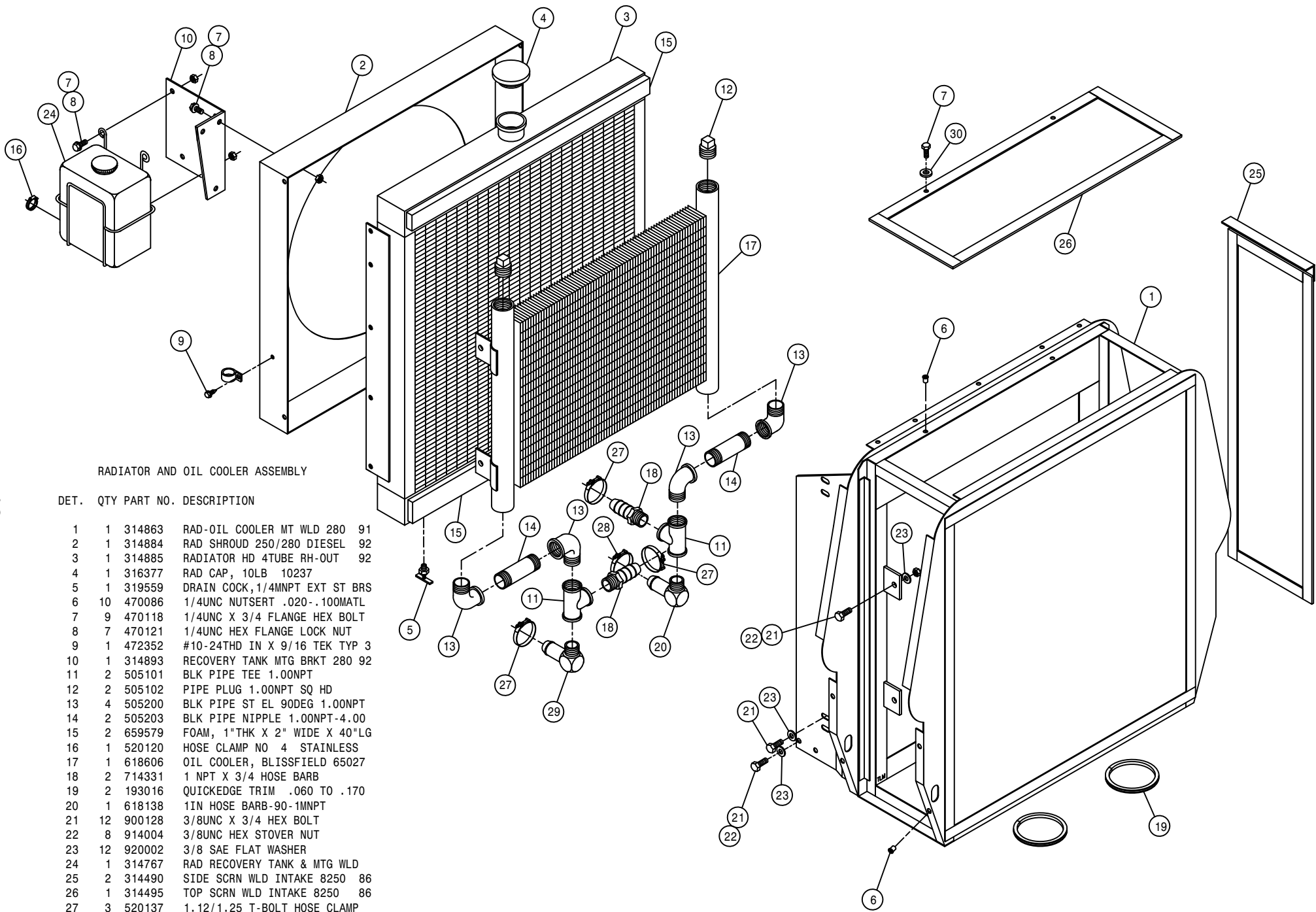

RADIATOR AND OIL COOLER ASSEMBLY

DET. QTY PART NO. DESCRIPTION

1	1	314863	RAD-OIL COOLER MT WLD 280	91
2	1	314884	RAD SHROUD 250/280 DIESEL	92
3	1	314885	RADIATOR HD 4TUBE RH-OUT	92
4	1	316377	RAD CAP, 10LB 10237	
5	1	319559	DRAIN COCK, 1/4MNPT EXT ST BRS	
6	10	470086	1/4UNC NUTSERT .020-.100MATL	
7	9	470118	1/4UNC X 3/4 FLANGE HEX BOLT	
8	7	470121	1/4UNC HEX FLANGE LOCK NUT	
9	1	472352	#10-24THD IN X 9/16 TEK TYP 3	
10	1	314893	RECOVERY TANK MTG BRKT 280	92
11	2	505101	BLK PIPE TEE 1.00NPT	
12	2	505102	PIPE PLUG 1.00NPT SQ HD	
13	4	505200	BLK PIPE ST EL 90DEG 1.00NPT	
14	2	505203	BLK PIPE NIPPLE 1.00NPT-4.00	
15	2	659579	FOAM, 1"THK X 2" WIDE X 40"LG	
16	1	520120	HOSE CLAMP NO 4 STAINLESS	
17	1	618606	OIL COOLER, BLISSFIELD 65027	
18	2	714331	1 NPT X 3/4 HOSE BARB	
19	2	193016	QUICKEDGE TRIM .060 TO .170	
20	1	618138	1IN HOSE BARB-90-1MNPT	
21	12	900128	3/8UNC X 3/4 HEX BOLT	
22	8	914004	3/8UNC HEX STOVER NUT	
23	12	920002	3/8 SAE FLAT WASHER	
24	1	314767	RAD RECOVERY TANK & MTG WLD	
25	2	314490	SIDE SCR N WLD INTAKE 8250	86
26	1	314495	TOP SCR N WLD INTAKE 8250	86
27	3	520137	1.12/1.25 T-BOLT HOSE CLAMP	
28	1	520138	1.38/1.56 T-BOLT HOSE CLAMP	
29	1	716000	3/4 HOSE BARB-90-1MNPT	
30	2	470212	1/4 BONDED SEALING WASH, SS	

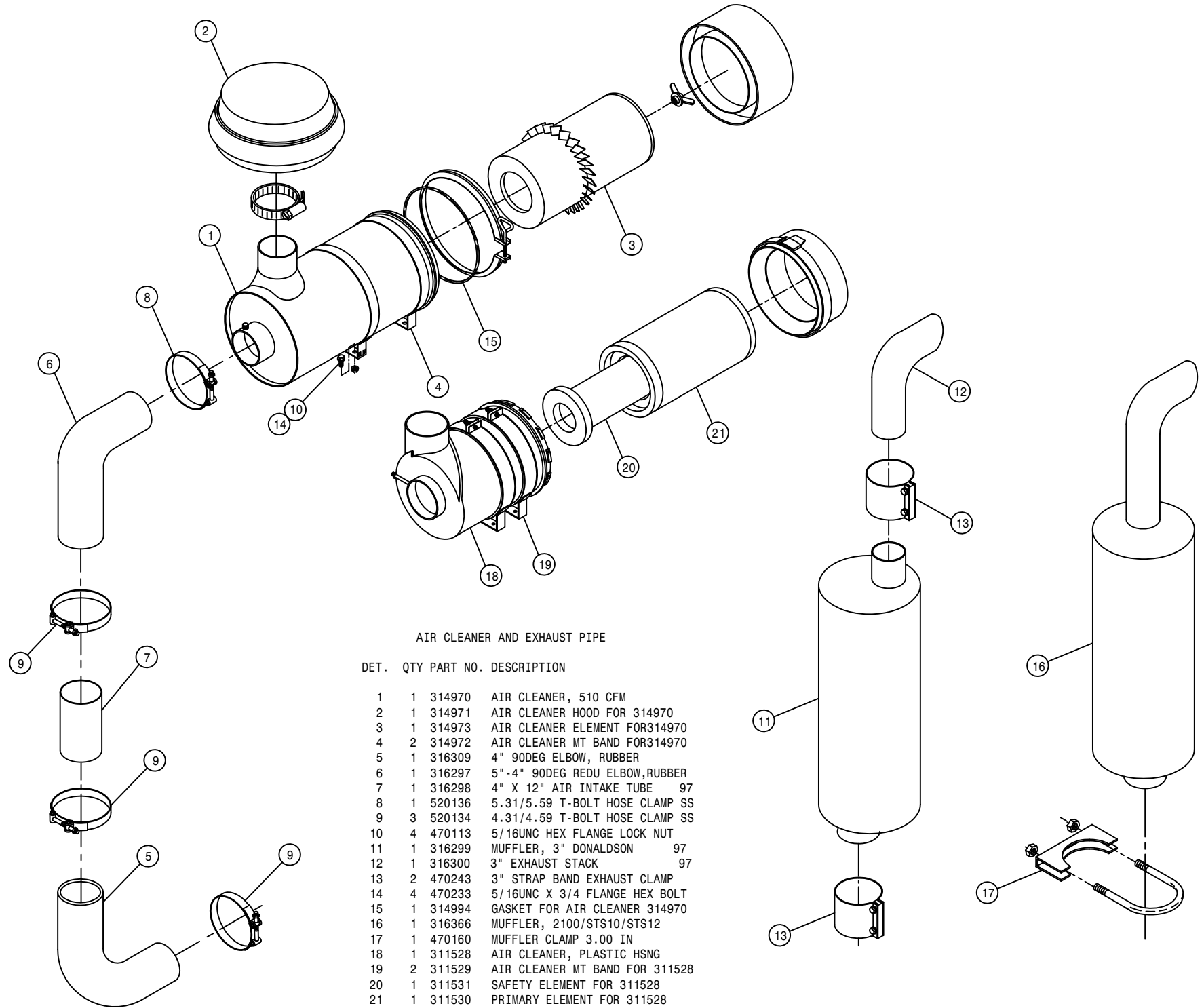

AIR CLEANER AND EXHAUST PIPE

DET.	QTY	PART NO.	DESCRIPTION
	1	314970	AIR CLEANER, 510 CFM
	2	314971	AIR CLEANER HOOD FOR 314970
	3	314973	AIR CLEANER ELEMENT FOR314970
	4	314972	AIR CLEANER MT BAND FOR314970
	5	316309	4" 90DEG ELBOW, RUBBER
	6	316297	5"-4" 90DEG REDU ELBOW,RUBBER
	7	316298	4" X 12" AIR INTAKE TUBE 97
	8	520136	5.31/5.59 T-BOLT HOSE CLAMP SS
	9	520134	4.31/4.59 T-BOLT HOSE CLAMP SS
	10	470113	5/16UNC HEX FLANGE LOCK NUT
	11	316299	MUFFLER, 3" DONALDSON 97
	12	316300	3" EXHAUST STACK 97
	13	470243	3" STRAP BAND EXHAUST CLAMP
	14	470233	5/16UNC X 3/4 FLANGE HEX BOLT
	15	314994	GASKET FOR AIR CLEANER 314970
	16	316366	MUFFLER, 2100/STS10/STS12
	17	470160	MUFFLER CLAMP 3.00 IN
	18	311528	AIR CLEANER, PLASTIC HSNG
	19	311529	AIR CLEANER MT BAND FOR 311528
	20	311531	SAFETY ELEMENT FOR 311528
	21	311530	PRIMARY ELEMENT FOR 311528

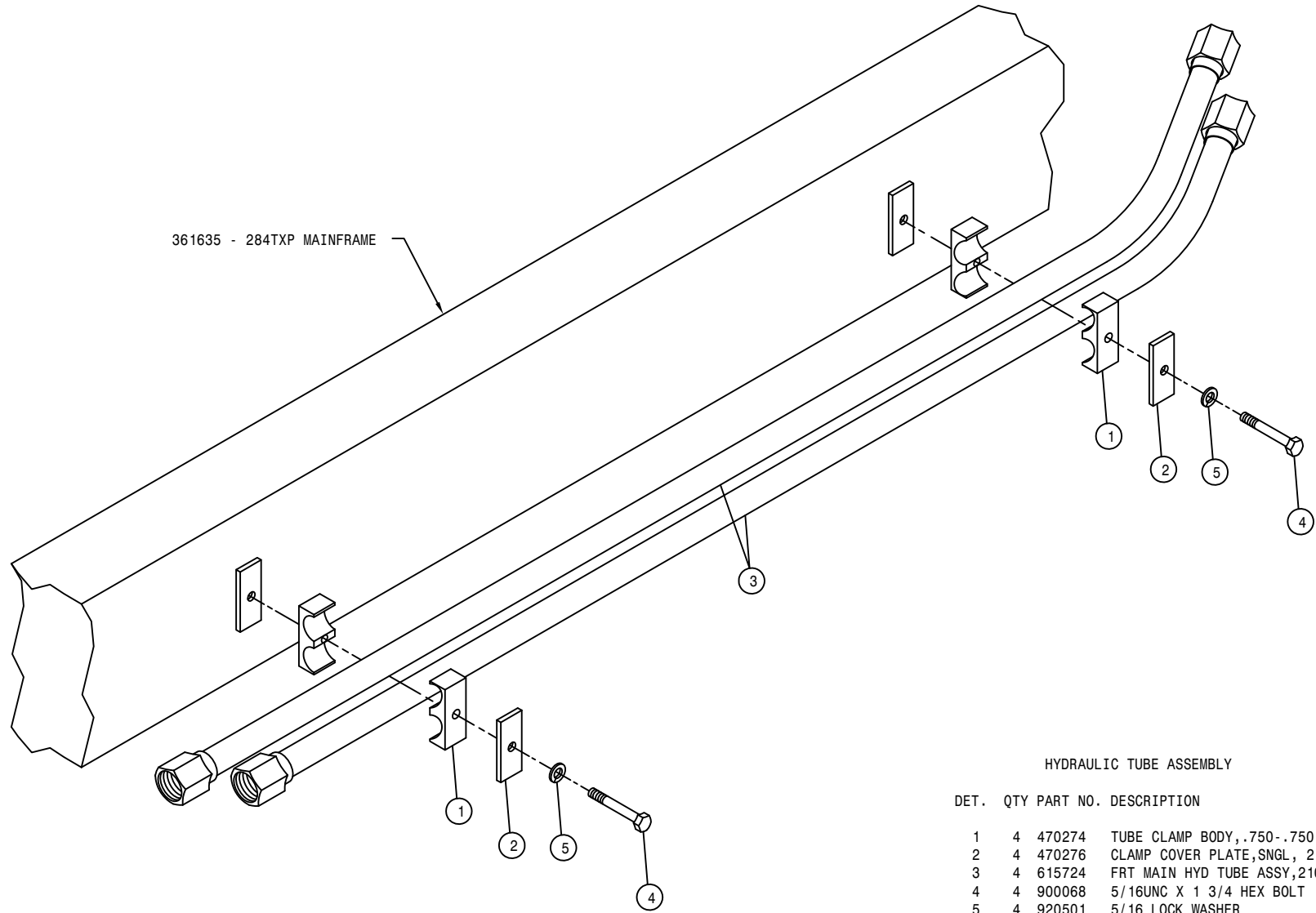

361635 - 284TXP MAINFRAME

HYDRAULIC TUBE ASSEMBLY

DET.	QTY	PART NO.	DESCRIPTION
	4	470274	TUBE CLAMP BODY, .750-.750
	4	470276	CLAMP COVER PLATE, SNGL, 2.55LG
	4	615724	FRT MAIN HYD TUBE ASSY, 2100 98
	4	900068	5/16UNC X 1 3/4 HEX BOLT
	4	920501	5/16 LOCK WASHER

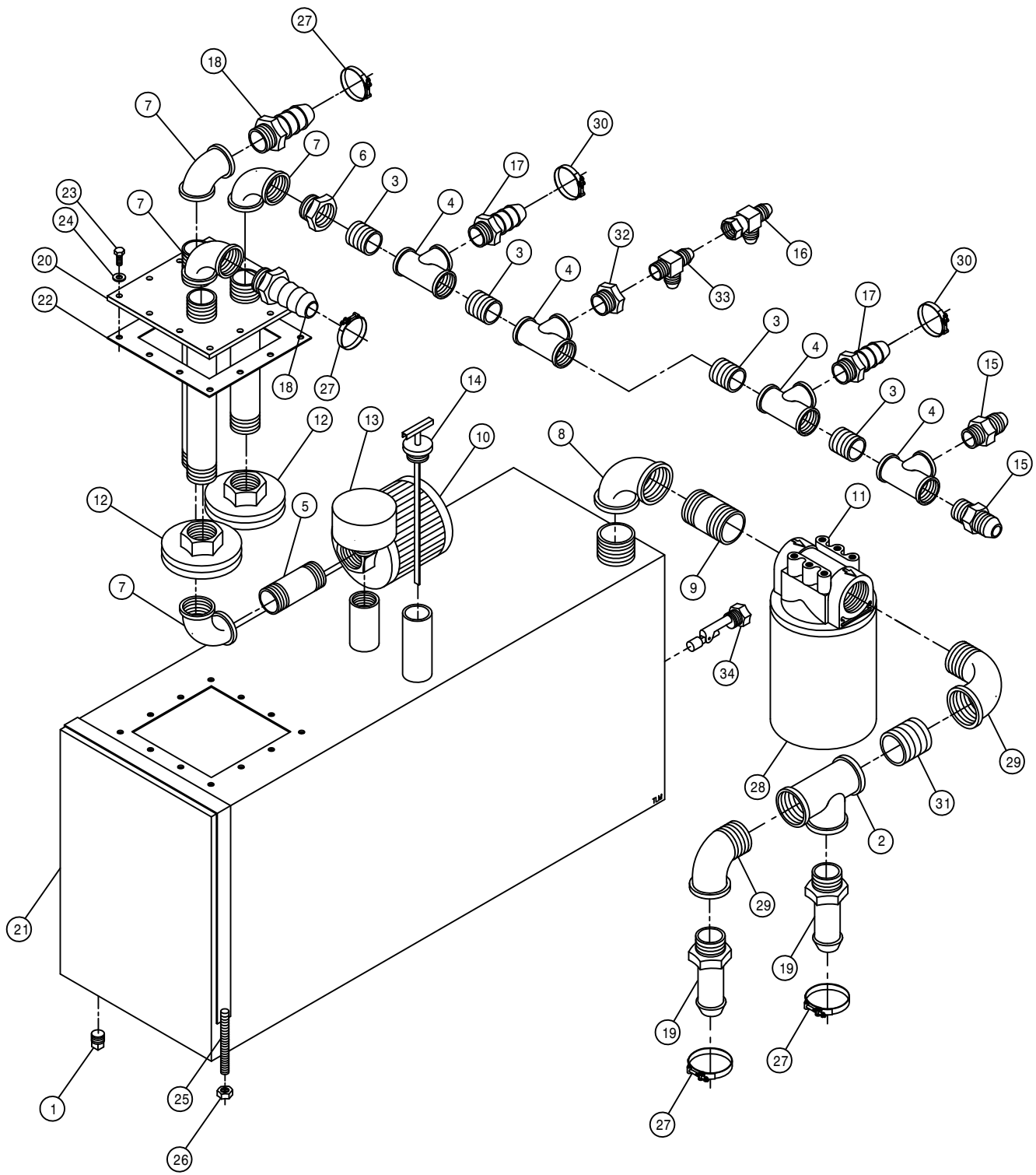

HYDRAULIC TANK ASSEMBLY

DET.	QTY	PART NO.	DESCRIPTION
1	1	470308	1/2MNPT DRAIN PLUG,AL HD,MAG
2	1	506105	BLK PIPE TEE 1.25NPT
3	4	504702	CLOSE NIPPLE .75NPT
4	4	504955	BLK PIPE TEE .75NPT
5	1	505203	BLK PIPE NIPPLE 1.00NPT-4.00
6	1	505213	RED BUSH 1 X 3/4 BLK MAL
7	4	505300	BLK PIPE EL 90DEG 1.00NPT
8	1	506303	BLK PIPE EL 90DEG 1.25NPT
9	1	506602	PIPE NIPPLE 1 1/4NPT-2 1/2
10	1	605600	TANK FILTER, 100 MESH,1"FNPT
11	1	605601	PARKER FILTER ASSY,10M,1.25NPT
12	2	605603	LINE SUMP DIFFUSER
13	1	611052	FILLER BREATHER 3/4NPT
14	1	614453	DIPSTICK, 8IN
15	2	610300	3/4MJIC-3/4MNPT ADPTR
16	1	618486	9/16FJIC SW RUN TEE-9/16MJIC
17	2	713220	HOSE BARB 3/4 NPT X 3/4
18	2	714560	1NPT X 1 HOSE BARB
19	2	715664	1 1/4 NPT X 1 HOSE BARB
20	1	760090	RECEIVER PLT WLD 8240
21	1	760264	HYD TANK WLD,204/254/284 2002
22	1	763039	HYD MTR MTG PLT GSKT
23	12	900064	5/16UNC X 3/4 HEX BOLT
24	12	920001	5/16 SAE FLAT WASHER
25	2	341360	OIL TANK STRAP WLD 8240 1982
26	4	914004	3/8UNC HEX STOVER NUT
27	4	520138	1.38/1.56 T-BOLT HOSE CLAMP
28	1	605602	PARKER FILTER ELEMENT,10MICRON
29	2	506410	BLK PIPE ST EL 90DEG 1.25NPT
30	2	520137	1.12/1.25 T-BOLT HOSE CLAMP
31	1	506200	CLOSE NIPPLE 1.25NPT
32	1	504001	RED BUSH 3/4 X 1/4 BLK MAL
33	1	618520	1/4MNPT RUN TEE-9/16MJIC
34	1	470350	LIQUID LEVEL SWITCH ASSY,1/2NP



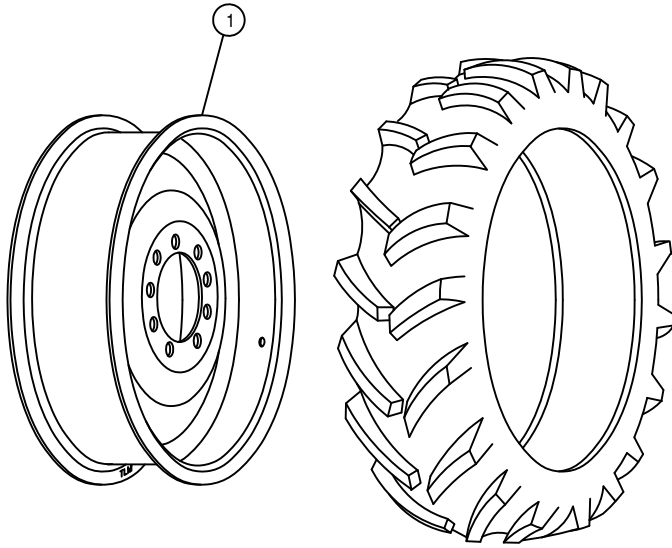

13.6-38 6 PLY TIRE

TIRE AND RIM ASSEMBLY

DET. QTY PART NO. DESCRIPTION

1	1	821050	RIM WLD, W10 X 38, W1M1	204
---	---	--------	-------------------------	-----

RIGHT FRONT LEG ASSEMBLY

DET.	QTY	PART NO.	DESCRIPTION
1	2	121029	JOURNAL BRG, 1.00 ID X 1.00 LG
2	2	121105	LEG TOWER SLIDE BEARING, ORKOT
3	1	125050	BRG CONE, 1.00 ID W/FACE SEAL
4	1	125051	BRG CUP FOR 125050
5	1	125052	BRG CONE, 2.687 ID W/FACE SEAL
6	1	125053	BRG CUP FOR 125052
7	2	311058	RUBBER SPRING
8	1	311066	AIRIDE SPRING, STS12
9	1	311067	HEIGHT CONTROL AIR VALVE
10	1	311069	7.00 LEVER, CTRL AIR VLV 311067
11	1	311070	LEVER SCREW, CTRL AIR VLV 311067
12	1	358564	FRT LEG LWR NYL SLEEVE 280 89
13	1	358565	FRT LEG UPR NYL SLEEVE 280 89
14	4	358927	LWR BRG KPR, LEG 98
15	1	359049	RH LEG AIR VALVE MT
16	1	359051	LWR AIR VALVE ARM MT
17	1	359052	AIR BAG TOWER TOP MT WLD
18	1	359082	STEERING ARM BRG SPACER
19	1	359095	LEG HEIGHT CTRL LINKAGE, STS12
20	1	359224	UPPER TRUNNION MT WLD 284TXP03
21	1	359226	RH AIR BAG LWR PLT WLD, 284TXP
22	2	359230	NITRO TOWER SHAFT WLD, 284TXP03
23	2	359232	TOWER SPACER WLD, 284TXP 03
24	1	359235	RH STEERING ARM WLD, 284TXP 03
25	1	359244	INNER LEG WLD, 284TXP 03
26	1	359255	RH FRT OUTER LEG WLD, 284TXP 03
27	2	470117	COTTER PIN 3/16 1 3/4 SQ CUT
28	1	470265	KEY, .250 X .375 X 1.88 LG
29	2	471005	1/4 28 X 1/2 GREASE ZERK
30	2	471023	GREASE ZERK 1/4-28 X 45
31	1	472322	7/8-14 UNF HEX JAM NUT
32	1	473983	ROD END.875 BORE.875-14 RH FEM
33	2	711036	1/8MNPT-1/4 NYL TUBE FTG
34	1	711040	1/4MNPT-90-1/4 NYL TUBE LBO
35	2	900006	1/4UNC X 1 3/4 HEX BOLT
36	8	900064	5/16UNC X 3/4 HEX BOLT
37	4	900265	1/2UNC X 1 1/2 HEX BOLT
38	16	900266	1/2UNC X 1 3/4 HEX BOLT
39	4	900269	1/2UNC X 2 3/4 HEX BOLT
40	2	900352P	5/8UNC X 2 1/4 HEX BOLT
41	4	900836	5/8UNF X 3 1/4 HEX BOLT GR8
42	1	910008	1/2UNC HEX NUT
43	1	910013	3/4UNF HEX NUT
44	1	910021	1" - 14 SLOT JAM NUT
45	2	914000	1/4UNC HEX STOVER NUT
46	20	914008	1/2UNC HEX STOVER NUT
47	2	914010P	5/8UNC HEX STOVER NUT
48	14	914811	5/8UNF HEX NUT GR8
49	1	920008	1" SAE FLAT WASHER
50	8	920501	5/16 LOCK WASHER
51	7	920504	1/2 LOCK WASHER
52	1	920506	3/4 LOCK WASHER
53	1	621007	STEERING CYL ASSY, 284TXP 03
54	1	825013	7/8-14UNF SLOTTED HEX NUT
55	1	359239	STEERING ARM BOLT, 284TXP 03
56	1	358996	RH UPPER HOSE MT WELD, 2100 99
57	2	900263	1/2UNC X 1" HEX BOLT
58	1	470347	HOSE CLAMP BODY, 1.16-1.16
59	1	470270	HOSE CLAMP BODY, .530-.680
60	1	470276	CLAMP COVER PLATE, SNGL, 2.55LG
61	1	470280	STACK BOLT, 5/16UNC X 1 3/4
62	1	470281	STACK BOLT SAFETY LOCK PLATE
63	1	900068	5/16UNC X 1 3/4 HEX BOLT
64	3	900837	5/8UNF X 3 1/2 HEX BOLT GR8
65	1	358759	LEG MT V-PLT WLD, 284T 94
66	1	601415	HOSE, 1/4 X 108 AIR
67	1	601473	HOSE, 1/4 X 22 AIR
68	1	342635	NYL HOSE SLEEVE, 2.64ID X 60.00
69	1	342638	NYL HOSE SLEEVE, 2.96ID X 65.00
70	1	342654	NYL HOSE SLEEVE, 3.66ID X 24.00
71	1	483019	7/8" INTERNAL TOOTH LOCK WASHER

NOTE: TOWER SPACER IS ONLY USED FOR TRANSPORTING.

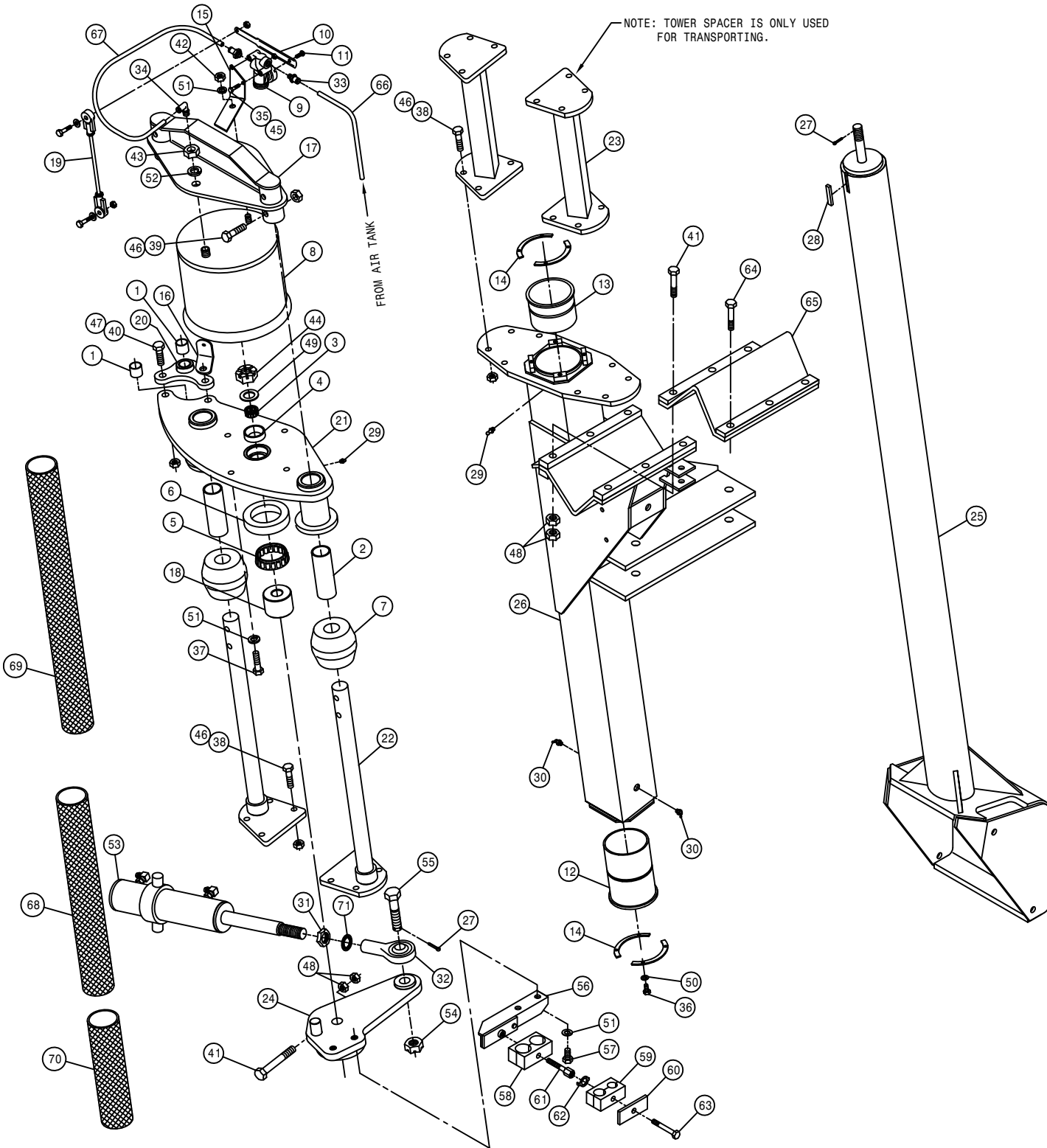

18

300018

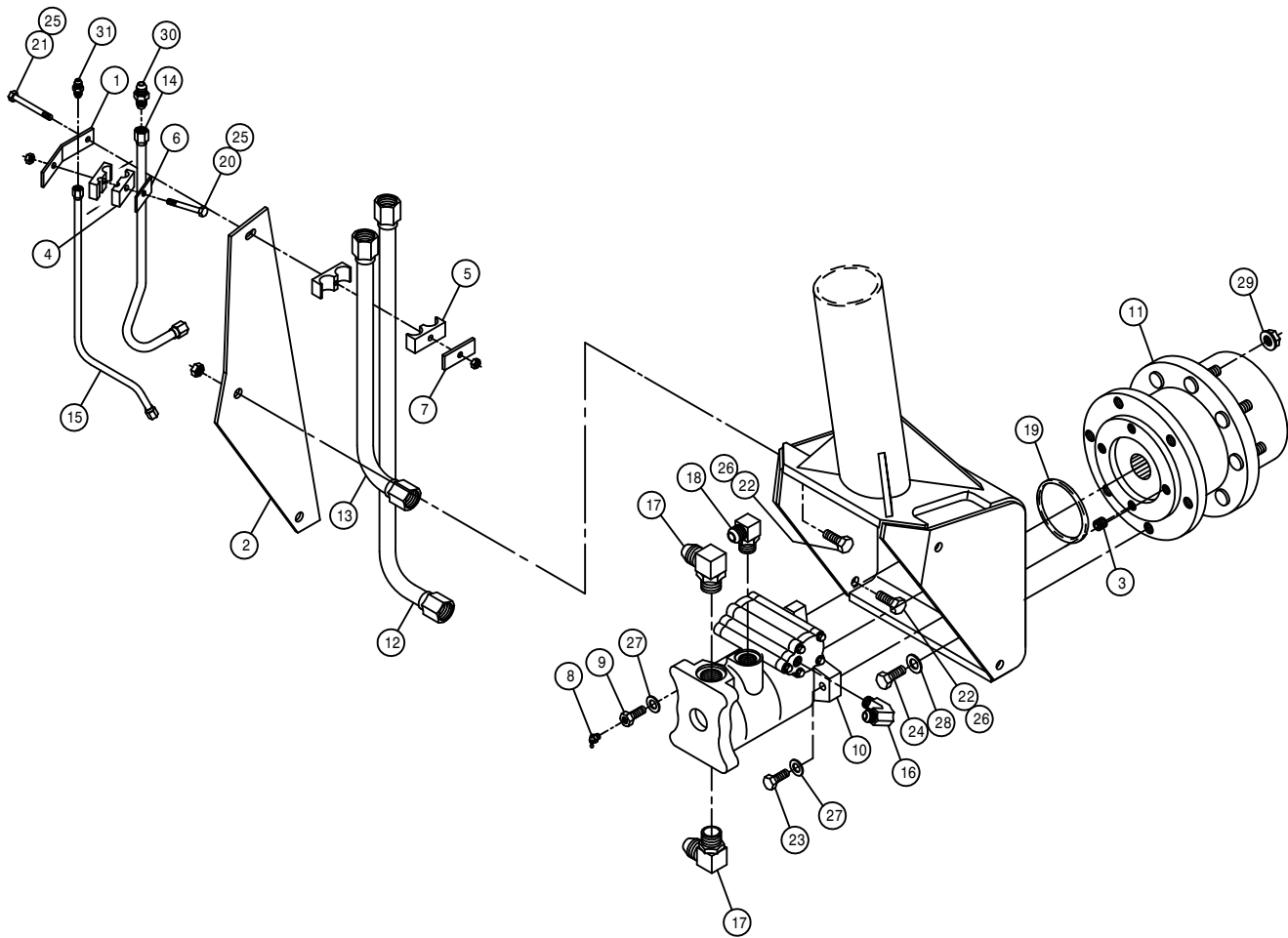

RIGHT FRONT LEG ASSEMBLY

DET.	QTY	PART NO.	DESCRIPTION
	1	358926	FRT LEG HYD TUBE BRKT, 2100 98
	2	359243	HYD TUBE MTG PLT, 284TXP 03
	3	470066	1/2UNC X 1/2 AL HD CUP SET SCR
	4	470272	TUBE CLAMP BODY, .375-.500
	5	470275	TUBE CLAMP BODY, 1.000-1.000
	6	470277	CLAMP WELD PLATE, SNGL, 2.15LG
	7	470278	CLAMP WELD PLATE, SNGL, 2.75LG
	8	471023	GREASE ZERK 1/4-28 X 45
	9	610634	ZERK BOLT, 1 1/2, TORQ HUB
	10	610637	SUND HYD MOTOR, M46-4019
	11	610692	TORQ HUB, 30:1 B-MT MW3BA
	12	615708	LWR HYD TUBE ASSY,LEG 2100 98
	13	615709	UPR HYD TUBE ASSY,LEG 2100 98
	14	615710	RF/LR HYD DRN TUBE ASSY2100 98
	15	615712	RF/LR HYD CTRL TUBE ASSY210098
	16	618119	9/16MJIC-90-9/16MOR LBO
	17	618178	1 5/16MJIC-90-1 5/16MOR LBO
	18	618474	3/4MJIC-90-1 1/16MOR LBO
	19	870045	O-RING 4 1/8 OD X 4 ID
	20	900068	5/16UNC X 1 3/4 HEX BOLT
	21	900070	5/16UNC X 2 1/2 BOLT
	22	900264	1/2UNC X 1 1/4 HEX BOLT
	23	900266P	1/2UNC X 1 3/4 HEX BOLT
	24	900333P	5/8UNC X 1 1/2 HEX BOLT
	25	914002	5/16UNC HEX STOVER NUT
	26	914008	1/2UNC HEX STOVER NUT
	27	920504P	1/2 LOCK WASHER
	28	920505P	5/8 LOCK WASHER
	29	470140	5/8UNF HEX SMTH FLANGE NUT PLT
	30	618314	3/4MJIC UNION
	31	619010	9/16MJIC UNION

NOTE: TOWER SPACER IS ONLY USED FOR TRANSPORTING.

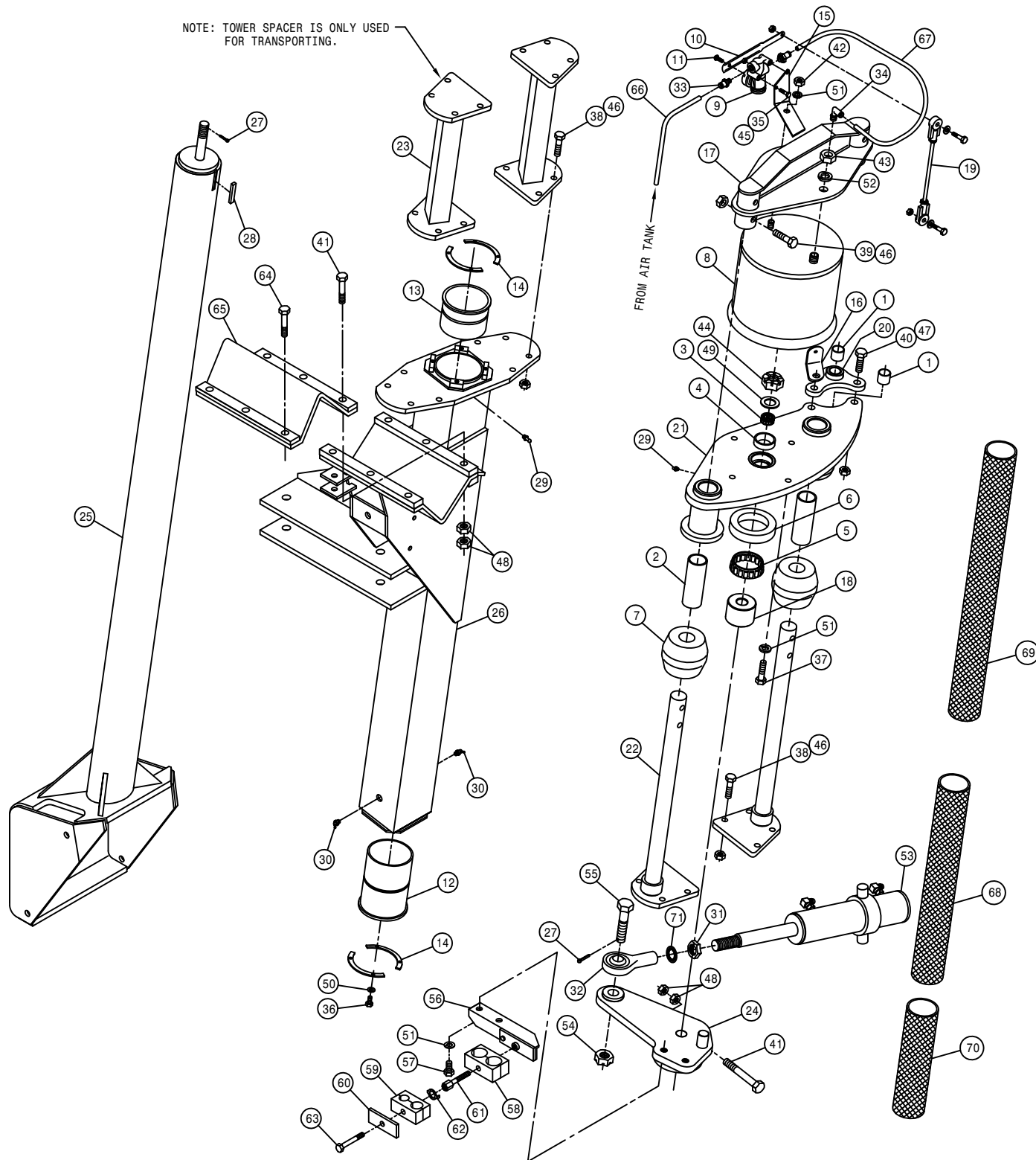

LEFT FRONT LEG ASSEMBLY

DET.	QTY	PART NO.	DESCRIPTION	
	1	2	121029	JOURNAL BRG, 1.00 ID X 1.00 LG
	2	2	121105	LEG TOWER SLIDE BEARING, ORKOT
	3	1	125050	BRG CONE, 1.00 ID W/FACE SEAL
	4	1	125051	BRG CUP FOR 125050
	5	1	125052	BRG CONE, 2.687 ID W/FACE SEAL
	6	1	125053	BRG CUP FOR 125052
	7	2	311058	RUBBER SPRING
	8	1	311066	AIRIDE SPRING, STS12
	9	1	311067	HEIGHT CONTROL AIR VALVE
	10	1	311069	7.00 LEVER, CTRL AIR VLV 311067
	11	1	311070	LEVER SCREW, CTRL AIR VLV311067
	12	1	358564	FRT LEG LWR NYL SLEEVE 280 89
	13	1	358565	FRT LEG UPR NYL SLEEVE 280 89
	14	4	358927	LWR BRG KPR, LEG 98
	15	1	359050	LH LEG AIR VALVE MT
	16	1	359051	LWR AIR VALVE ARM MT
	17	1	359052	AIR BAG TOWER TOP MT WLD
	18	1	359082	STEERING ARM BRG SPACER
	19	1	359095	LEG HEIGHT CTRL LINKAGE, STS12
	20	1	359224	UPPER TRUNNION MT WLD 284TXP03
	21	1	359227	LH AIR BAG LWR PLT WLD, 284TXP
	22	2	359230	NITRO TOWER SHAFT WLD, 284TXP03
	23	2	359232	TOWER SPACER WLD, 284TXP 03
	24	1	359236	LH STEERING ARM WLD, 284TXP 03
	25	1	359244	INNER LEG WLD, 284TXP 03
	26	1	359256	LH FRT OUTER LEG WLD, 284TXP 03
	27	2	470117	COTTER PIN 3/16 1 3/4 SQ CUT
	28	1	470265	KEY, .250 X .375 X 1.88 LG
	29	2	471005	1/4 28 X 1/2 GREASE ZERK
	30	2	471023	GREASE ZERK 1/4-28 X 45
	31	1	472322	7/8-14 UNF HEX JAM NUT
	32	1	473983	ROD END.875 BORE.875-14 RH FEM
	33	2	711036	1/8MNPT-1/4 NYL TUBE FTG
	34	1	711040	1/4MNPT-90-1/4 NYL TUBE LBO
	35	2	900006	1/4UNC X 1 3/4 HEX BOLT
	36	8	900064	5/16UNC X 3/4 HEX BOLT
	37	4	900265	1/2UNC X 1 1/2 HEX BOLT
	38	16	900266	1/2UNC X 1 3/4 HEX BOLT
	39	4	900269	1/2UNC X 2 3/4 HEX BOLT
	40	2	900352P	5/8UNC X 2 1/4 HEX BOLT
	41	4	900836	5/8UNF X 3 1/4 HEX BOLT GR8
	42	1	910008	1/2UNC HEX NUT
	43	1	910013	3/4UNF HEX NUT
	44	1	910021	1"-14 SLOT JAM NUT
	45	2	914000	1/4UNC HEX STOVER NUT
	46	20	914008	1/2UNC HEX STOVER NUT
	47	2	914010P	5/8UNC HEX STOVER NUT
	48	14	914811	5/8UNF HEX NUT GR8
	49	1	920008	1" SAE FLAT WASHER
	50	8	920501	5/16 LOCK WASHER
	51	7	920504	1/2 LOCK WASHER
	52	1	920506	3/4 LOCK WASHER
	53	1	621007	STEERING CYL ASSY, 284TXP 03
	54	1	825013	7/8-14UNF SLOTTED HEX NUT
	55	1	359239	STEERING ARM BOLT, 284TXP 03
	56	1	358997	LH UPPER HOSE MT WELD, 2100 99
	57	2	900263	1/2UNC X 1" HEX BOLT
	58	1	470347	HOSE CLAMP BODY, 1.16-1.16
	59	1	470270	HOSE CLAMP BODY, .530-.680
	60	1	470276	CLAMP COVER PLATE, SINGL, 2.55LG
	61	1	470280	STACK BOLT, 5/16UNC X 1 3/4
	62	1	470281	STACK BOLT SAFETY LOCK PLATE
	63	1	900068	5/16UNC X 1 3/4 HEX BOLT
	64	3	900839	3/8UNC X 3 1/4 HEX BOLT GR8
	65	1	358759	LEG MT V-PLT WLD, 284T 94
	66	1	601415	HOSE, 1/4 X 108 AIR
	67	1	601473	HOSE, 1/4 X 22 AIR
	68	1	342635	NYL HOSE SLEEVE, 2.64ID X 60.00
	69	1	342638	NYL HOSE SLEEVE, 2.96ID X 65.00
	70	1	342654	NYL HOSE SLEEVE, 3.66ID X 24.00
	71	4	483019	7/8" INTERNAL TOOTH LOCK WASHER

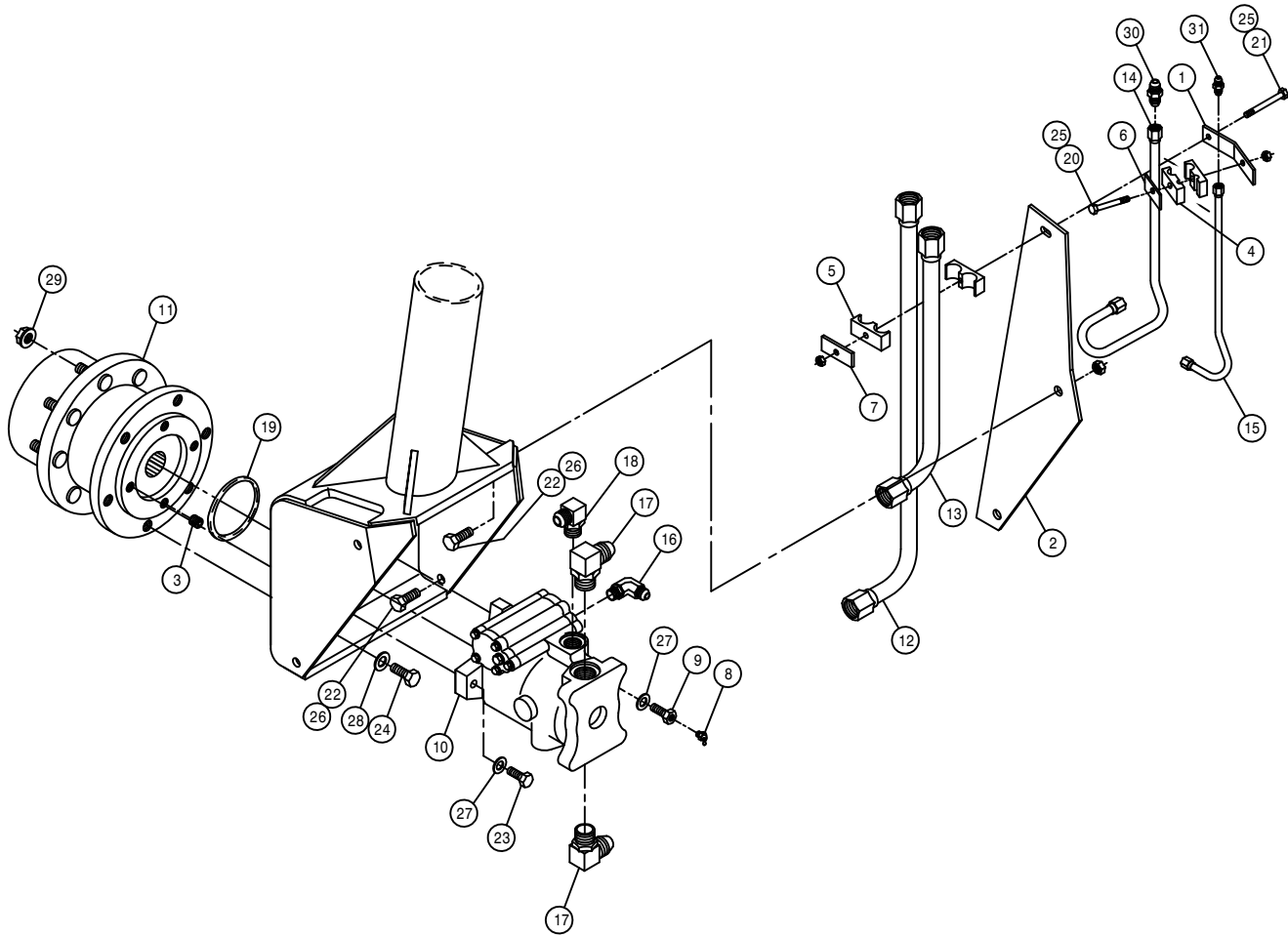

LEFT FRONT LEG ASSEMBLY

DET.	QTY	PART NO.	DESCRIPTION
1	1	358926	FRT LEG HYD TUBE BRKT, 2100 98
2	1	359243	HYD TUBE MTG PLT, 284TXP 03
3	1	470066	1/2UNC X 1/2 AL HD CUP SET SCR
4	1	470272	TUBE CLAMP BODY, .375- .500
5	1	470275	TUBE CLAMP BODY, 1.000-1.000
6	1	470277	CLAMP WELD PLATE, SNGL, 2.15LG
7	1	470278	CLAMP WELD PLATE, SNGL, 2.75LG
8	1	471023	GREASE ZERK 1/4-28 X 45
9	1	610634	ZERK BOLT, 1 1/2, TORQ HUB
10	1	610637	SUND HYD MOTOR, M46-4019
11	1	610692	TORQ HUB, 30:1 B-MT MW3BA
12	1	615708	LWR HYD TUBE ASSY,LEG 2100 98
13	1	615808	UPR HYD TUBE ASSY,LEG 2100 03
14	1	615809	LF/RR HYD DRN TUBE ASSY2100 03
15	1	615713	LF/RR HYD CTRL TUBE ASSY210098
16	1	618119	9/16MJIC-90-9/16MOR LBO
17	2	618178	1 5/16MJIC-90-1 5/16MOR LBO
18	1	618474	3/4MJIC-90-1 1/16MOR LBO
19	1	870045	O-RING 4 1/8 OD X 4 ID
20	1	900068	5/16UNC X 1 3/4 HEX BOLT
21	1	900070	5/16UNC X 2 1/2 BOLT
22	2	900264	1/2UNC X 1 1/4 HEX BOLT
23	1	900266P	1/2UNC X 1 3/4 HEX BOLT
24	6	900333P	5/8UNC X 1 1/2 HEX BOLT
25	2	914002	5/16UNC HEX STOVER NUT
26	2	914008	1/2UNC HEX STOVER NUT
27	2	920504P	1/2 LOCK WASHER
28	6	920505P	5/8 LOCK WASHER
29	9	470140	5/8UNF HEX SMTH FLANGE NUT PLT
30	1	618314	3/4MJIC UNION
31	1	619010	9/16MJIC UNION

RH REAR LEG ASSEMBLY

DET.	QTY	PART NO.	DESCRIPTION
1	2	121029	JOURNAL BRG, 1.00 ID X 1.00 LG
2	2	121105	LEG TOWER SLIDE BEARING, ORKOT
3	1	125050	BRG CONE, 1.00 ID W/FACE SEAL
4	1	125051	BRG CUP FOR 125050
5	1	125052	BRG CONE, 2.687 ID W/FACE SEAL
6	1	125053	BRG CUP FOR 125052
7	2	311058	RUBBER SPRING
8	1	311066	AIRIDE SPRING, STS12
9	1	311067	HEIGHT CONTROL AIR VALVE
10	1	311069	7.00 LEVER, CTRL AIR VLV 311067
11	1	311070	LEVER SCREW, CTRL AIR VLV311067
12	1	358564	FRT LEG LWR NYL SLEEVE 280 89
13	1	358565	FRT LEG UPR NYL SLEEVE 280 89
14	4	358927	LWR BRG KPR, LEG 98
15	1	359049	RH LEG AIR VALVE MT
16	1	359051	LWR AIR VALVE ARM MT
17	1	359052	AIR BAG TOWER TOP MT WLD
18	1	359082	STEERING ARM BRG SPACER
19	1	359095	LEG HEIGHT CTRL LINKAGE, STS12
20	1	359224	UPPER TRUNNION MT WLD 284TXP03
21	1	359226	RH AIR BAG LWR PLT WLD, 284TXP
22	2	359230	NITRO TOWER SHAFT WLD, 284TXP03
23	2	359232	TOWER SPACER WLD, 284TXP 03
24	1	359235	RH STEERING ARM WLD, 284TXP 03
25	1	359240	REAR TIE ROD WLD, 284TXP 03
26	1	359244	INNER LEG WLD, 284TXP 03
27	1	359257	RH REAR OUTER LEG WLD, 284TXP03
28	2	470117	COTTER PIN 3/16 1 3/4 SQ CUT
29	1	470265	KEY, .250 X .375 X 1.88 LG
30	2	471005	1/4 28 X 1/2 GREASE ZERK
31	2	471023	GREASE ZERK 1/4-28 X 45
32	1	472322	7/8-14 UNF HEX JAM NUT
33	1	473983	ROD END.875 BORE.875-14 RH FEM
34	2	711036	1/8MNPT-1/4 NYL TUBE FTG
35	1	711040	1/4MNPT-90-1/4 NYL TUBE LBO
36	2	900006	1/4UNC X 1 3/4 HEX BOLT
37	4	900265	1/2UNC X 1 1/2 HEX BOLT
38	16	900266	1/2UNC X 1 3/4 HEX BOLT
39	4	900269	1/2UNC X 2 3/4 HEX BOLT
40	2	900352P	5/8UNC X 2 1/4 HEX BOLT
41	4	900836	5/8UNF X 3 1/4 HEX BOLT GR8
42	1	910008	1/2UNC HEX NUT
43	1	910013	3/4UNF HEX NUT
44	1	910021	1" -14 SLOT JAM NUT
45	2	914000	1/4UNC HEX STOVER NUT
46	20	914008	1/2UNC HEX STOVER NUT
47	2	914010P	5/8UNC HEX STOVER NUT
48	14	914811	5/8UNF HEX NUT GR8
49	1	920008	1" SAE FLAT WASHER
50	8	920501	5/16 LOCK WASHER
51	8	900064	5/16UNC X 3/4 HEX BOLT
52	5	920504	1/2 LOCK WASHER
53	1	920506	3/4 LOCK WASHER
54	1	359239	STEERING ARM BOLT, 284TXP 03
55	1	825013	7/8-14UNF SLOTTED HEX NUT
56	3	900837	5/8UNF X 3 1/2 HEX BOLT GR8
57	1	358759	LEG MT V-PLT WLD, 284T 94
58	1	601416	HOSE, 1/4 X 122 AIR
59	1	601473	HOSE, 1/4 X 22 AIR
60	1	342800	NYL HOSE SLEEVE, 3.34ID X 100
61	1	342654	NYL HOSE SLEEVE, 3.66ID X 24.00
62	1	483019	7/8" INTERNAL TOOTH LOCK WASHER

NOTE: TOWER SPACER IS ONLY USED FOR TRANSPORTING.

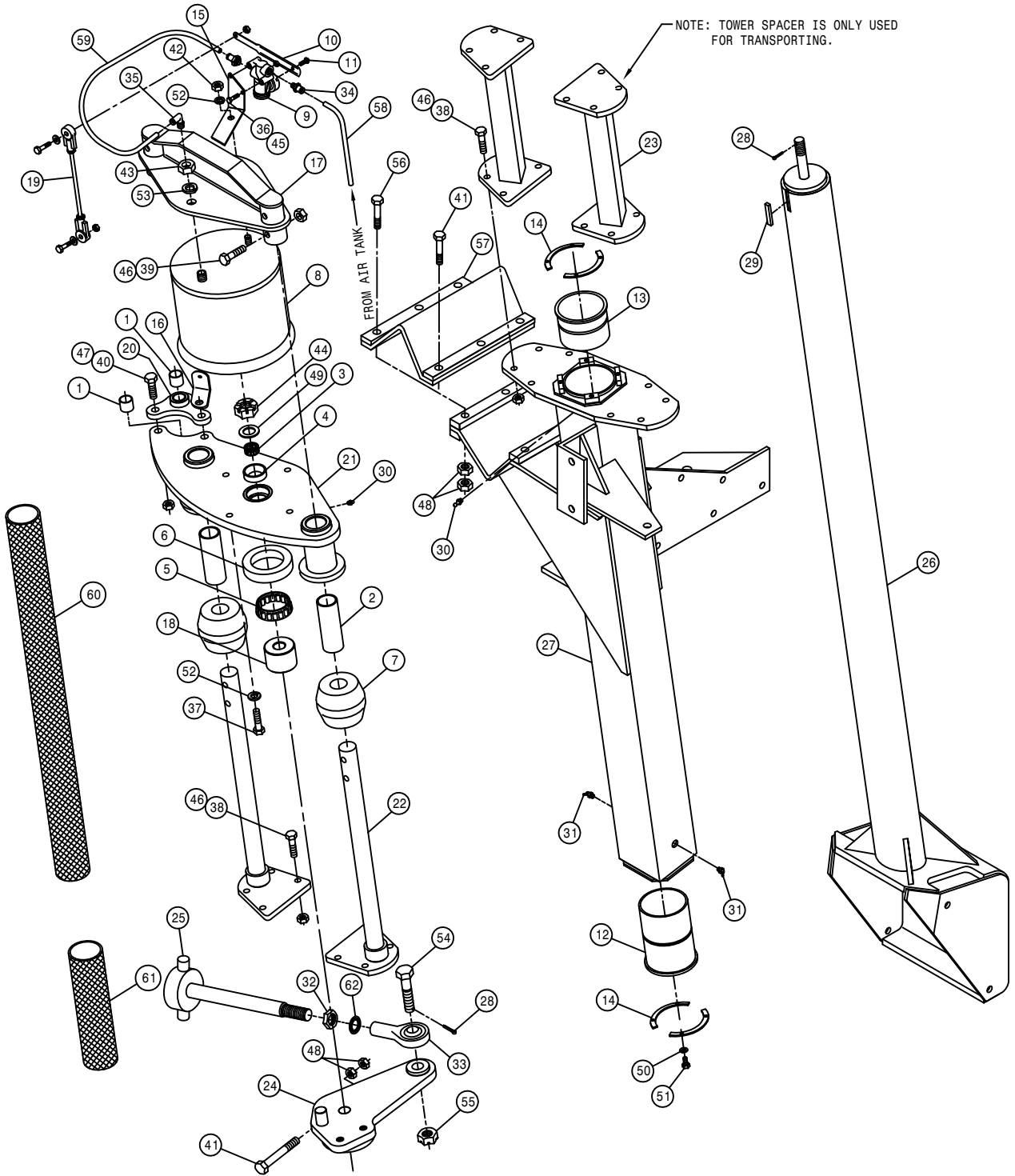

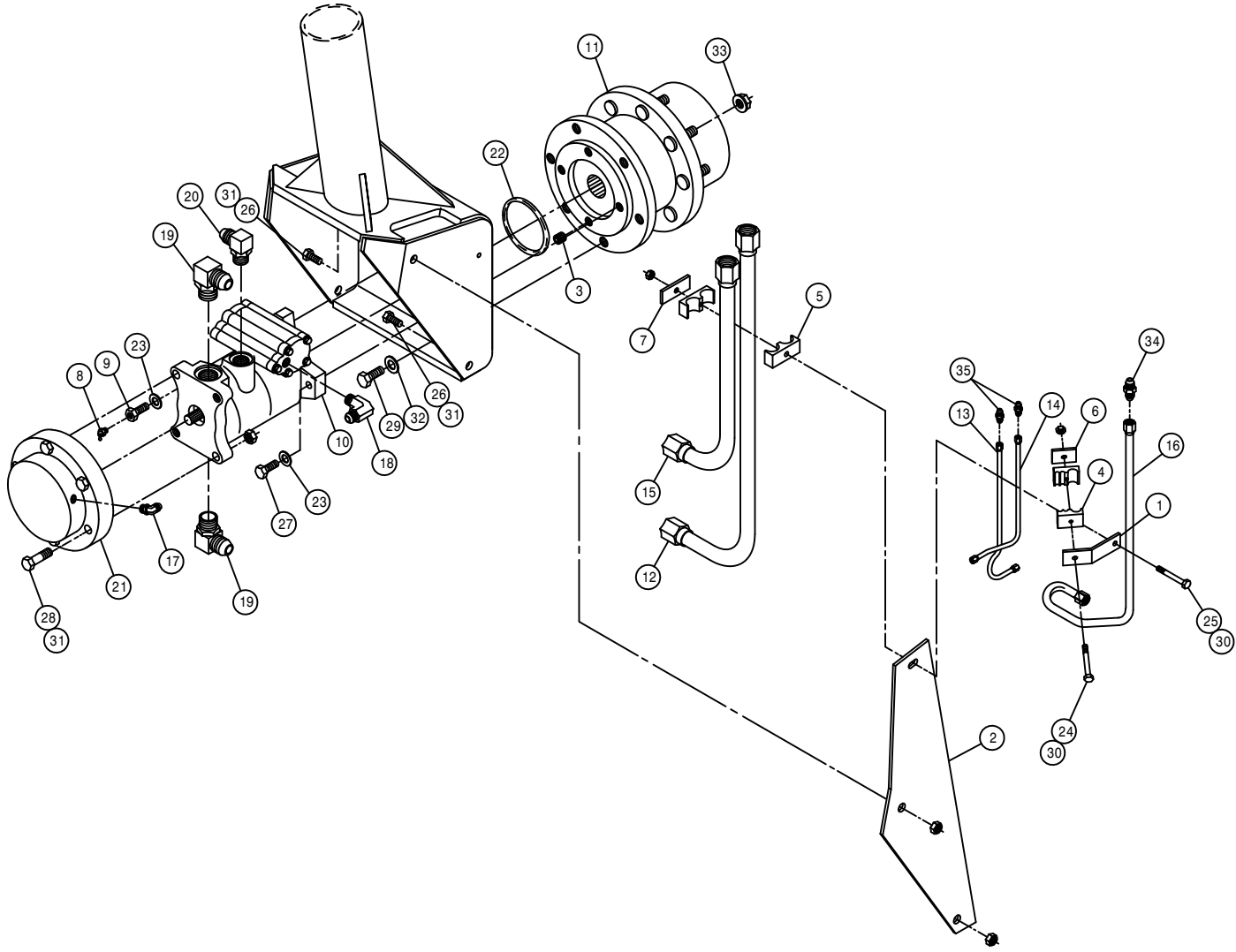

RH REAR LEG ASSEMBLY

DET.	QTY	PART NO.	DESCRIPTION
1	1	358934	REAR LEG HYD TUBE BRKT,2100 98
2	1	359243	HYD TUBE MTG PLT, 284TXP 03
3	1	470066	1/2UNC X 1/2 AL HD CUP SET SCR
4	1	470273	TUBE CLAMP BODY, .375-.375-.500
5	1	470275	TUBE CLAMP BODY,1.000-1.000
6	1	470277	CLAMP WELD PLATE, SNGL, 2.15LG
7	1	470278	CLAMP WELD PLATE, SNGL, 2.75LG
8	1	471023	GREASE ZERK 1/4-28 X 45
9	1	610634	ZERK BOLT, 1 1/2, TORQ HUB
10	1	610640	SUND HYD MOTOR, M46-4144
11	1	610692	TORQ HUB, 30:1 B-MT MW3BA
12	1	615708	LWR HYD TUBE ASSY,LEG 2100 98
13	1	615713	LF/RR HYD CTRL TUBE ASSY210098
14	1	615714	RH HYD BRAKE TUBE ASSY,2100 98
15	1	615808	UPR HYD TUBE ASSY,LEG 2100 03
16	1	615809	LF/RR HYD DRN TUBE ASSY2100 03
17	1	618114	9/16MJIC-90-7/16MOR LBO
18	1	618119	9/16MJIC-90-9/16MOR LBO
19	2	618178	1 5/16MJIC-90-1 5/16MOR LBO
20	1	618474	3/4MJIC-90-1 1/16MOR LBO
21	1	828093	MICO HYD BRAKE 98
22	1	870045	O-RING 4 1/8 OD X 4 ID
23	2	920504P	1/2 LOCK WASHER
24	1	900068	5/16UNC X 1 3/4 HEX BOLT
25	1	900070	5/16UNC X 2 1/2 BOLT
26	2	900264	1/2UNC X 1 1/4 HEX BOLT
27	1	900266P	1/2UNC X 1 3/4 HEX BOLT
28	2	900271	1/2UNC X 3 1/4 HEX BOLT
29	6	900333P	5/8UNC X 1 1/2 HEX BOLT
30	2	914002	5/16UNC HEX STOVER NUT
31	4	914008	1/2UNC HEX STOVER NUT
32	6	920505P	5/8 LOCK WASHER
33	9	470140	5/8UNF HEX SMTH FLANGE NUT PLT
34	1	618314	3/4MJIC UNION
35	2	619010	9/16MJIC UNION

LEFT REAR LEG ASSEMBLY

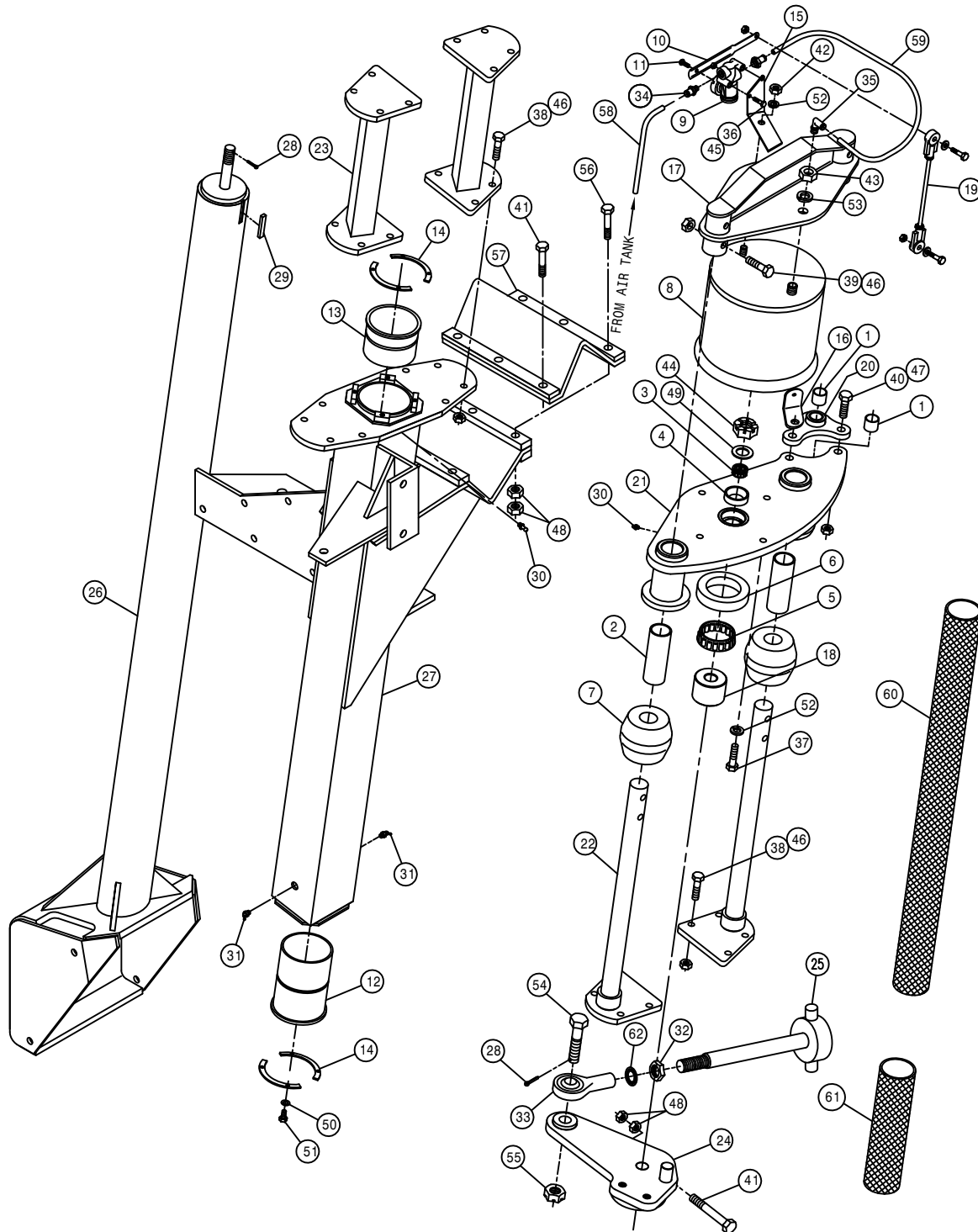

DET.	QTY	PART NO.	DESCRIPTION
1	2	121029	JOURNAL BRG, 1.00 ID X 1.00 LG
2	2	121105	LEG TOWER SLIDE BEARING, ORKOT
3	1	125050	BRG CONE, 1.00 ID W/FACE SEAL
4	1	125051	BRG CUP FOR 125050
5	1	125052	BRG CONE, 2.687 ID W/FACE SEAL
6	1	125053	BRG CUP FOR 125052
7	2	311058	RUBBER SPRING
8	1	311066	AIRIDE SPRING, STS12
9	1	311067	HEIGHT CONTROL AIR VALVE
10	1	311069	7.00 LEVER, CTRL AIR VLV 311067
11	1	311070	LEVER SCREW, CTRL AIR VLV311067
12	1	358564	FRT LEG LWR NYL SLEEVE 280 89
13	1	358565	FRT LEG UPR NYL SLEEVE 280 89
14	4	358927	LWR BRG KPR, LEG 98
15	1	359050	LH LEG AIR VALVE MT
16	1	359051	LWR AIR VALVE ARM MT
17	1	359052	AIR BAG TOWER TOP MT WLD
18	1	359082	STEERING ARM BRG SPACER
19	1	359095	LEG HEIGHT CTRL LINKAGE, STS12
20	1	359224	UPPER TRUNNION MT WLD 284TXP03
21	1	359227	LH AIR BAG LWR PLT WLD, 284TXP
22	2	359230	NITRO TOWER SHAFT WLD,284TXP03
23	2	359232	TOWER SPACER WLD, 284TXP 03
24	1	359236	LH STEERING ARM WLD, 284TXP 03
25	1	359240	REAR TIE ROD WLD, 284TXP 03
26	1	359244	INNER LEG WLD, 284TXP 03
27	1	359258	LH REAR OUTER LEG WLD,284TXP03
28	2	470117	COTTER PIN 3/16 1 3/4 SQ CUT
29	1	470265	KEY, .250 X .375 X 1.88 LG
30	2	471005	1/4 28 X 1/2 GREASE ZERK
31	2	471023	GREASE ZERK 1/4-28 X 45
32	1	472322	7/8-14 UNF HEX JAM NUT
33	1	473983	ROD END.875 BORE.875-14 RH FEM
34	2	711036	1/8MNPT-1/4 NYL TUBE FTG
35	1	711040	1/4MNPT-90-1/4 NYL TUBE LBO
36	2	900006	1/4UNC X 1 3/4 HEX BOLT
37	4	900265	1/2UNC X 1 1/2 HEX BOLT
38	16	900266	1/2UNC X 1 3/4 HEX BOLT
39	4	900269	1/2UNC X 2 3/4 HEX BOLT
40	2	900352P	5/8UNC X 2 1/4 HEX BOLT
41	4	900836	5/8UNF X 3 1/4 HEX BOLT GR8
42	1	910008	1/2UNC HEX NUT
43	1	910013	3/4UNF HEX NUT
44	1	910021	1" - 14 SLOT JAM NUT
45	2	914000	1/4UNC HEX STOVER NUT
46	20	914008	1/2UNC HEX STOVER NUT
47	2	914010P	5/8UNC HEX STOVER NUT
48	14	914811	5/8UNF HEX NUT GR8
49	1	920008	1" SAE FLAT WASHER
50	8	920501	5/16 LOCK WASHER
51	8	900064	5/16UNC X 3/4 HEX BOLT
52	5	920504	1/2 LOCK WASHER
53	1	920506	3/4 LOCK WASHER
54	1	359239	STEERING ARM BOLT, 284TXP 03
55	1	825013	7/8-14UNF SLOTTED HEX NUT
56	3	900837	5/8UNF X 3 1/2 HEX BOLT GR8
57	1	358759	LEG MT V-PLT WLD, 284T 94
58	1	601416	HOSE, 1/4 X 122 AIR
59	1	601473	HOSE, 1/4 X 22 AIR
60	1	342800	NYL HOSE SLEEVE,3.34ID X 100
61	1	342654	NYL HOSE SLEEVE,3.66ID X 24.00
62	1	483019	7/8"INTERNAL TOOTH LOCK WASHER



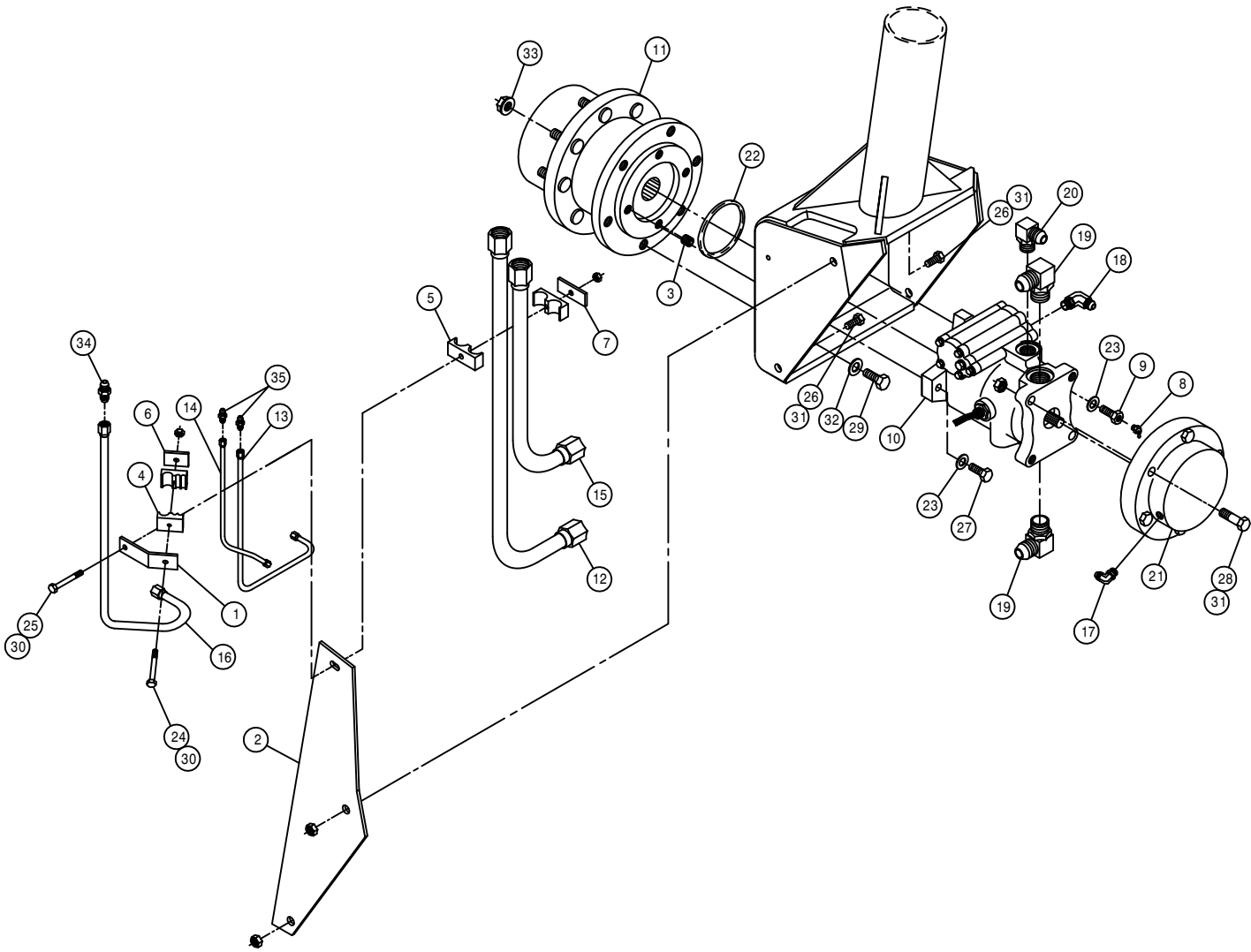

LEFT REAR LEG ASSEMBLY

DET.	QTY	PART NO.	DESCRIPTION
1	1	358934	REAR LEG HYD TUBE BRKT,2100 98
2	1	359243	HYD TUBE MTG PLT, 284TXP 03
3	1	470066	1/2UNC X 1/2 AL HD CUP SET SCR
4	1	470273	TUBE CLAMP BODY, .375-.375-.500
5	1	470275	TUBE CLAMP BODY,1.000-1.000
6	1	470277	CLAMP WELD PLATE, SNGL, 2.15LG
7	1	470278	CLAMP WELD PLATE, SNGL, 2.75LG
8	1	471023	GREASE ZERK 1/4-28 X 45
9	1	610634	ZERK BOLT, 1 1/2, TORQ HUB
10	1	610643	SUND HYD MOTOR, M46-4199 W/SEN
11	1	610692	TORQ HUB, 30:1 B-MT MW3BA
12	1	615708	LWR HYD TUBE ASSY,LEG 2100 98
13	1	615712	RF/LR HYD CTRL TUBE ASSY210098
14	1	615715	LH HYD BRAKE TUBE ASSY,2100 98
15	1	615709	UPR HYD TUBE ASSY,LEG 2100 98
16	1	615710	RF/LR HYD DRN TUBE ASSY2100 98
17	1	618114	9/16MJIC-90-7/16MOR LBO
18	1	618119	9/16MJIC-90-9/16MOR LBO
19	2	618178	1 5/16MJIC-90-1 5/16MOR LBO
20	1	618474	3/4MJIC-90-1 1/16MOR LBO
21	1	828093	MICO HYD BRAKE 98
22	1	870045	O-RING 4 1/8 OD X 4 ID
23	2	920504P	1/2 LOCK WASHER
24	1	900068	5/16UNC X 1 3/4 HEX BOLT
25	1	900070	5/16UNC X 2 1/2 BOLT
26	2	900264	1/2UNC X 1 1/4 HEX BOLT
27	1	900266P	1/2UNC X 1 3/4 HEX BOLT
28	2	900271	1/2UNC X 3 1/4 HEX BOLT
29	6	900333P	5/8UNC X 1 1/2 HEX BOLT
30	2	914002	5/16UNC HEX STOVER NUT
31	4	914008	1/2UNC HEX STOVER NUT
32	6	920505P	5/8 LOCK WASHER
33	9	470140	5/8UNF HEX SMTH FLANGE NUT PLT
34	1	618314	3/4MJIC UNION
35	2	619010	9/16MJIC UNION

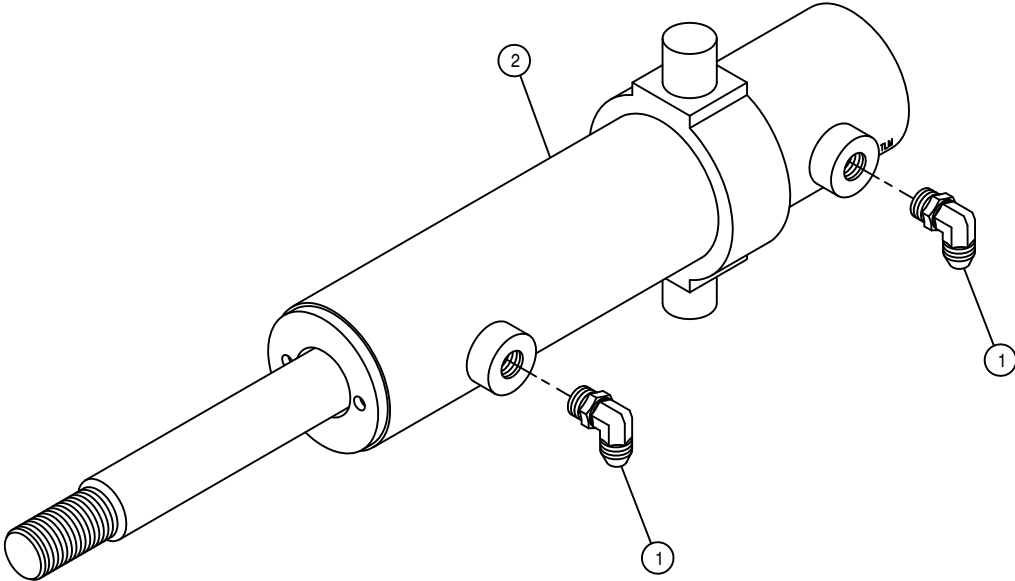

STEERING CYLINDER ASSEMBLY

DET.	QTY	PART NO.	DESCRIPTION	
	1	2	618119	9/16MJIC-90-9/16MOR LBO
	2	1	621512	STEERING CYL ASSY, 2.00 X 6.28
	NS	1	621513	REPAIR KIT, HYD CYL, STRG 621512

NOTE: 1. 621007 - STEERING CYLINDER ASSEMBLY WITH FITTINGS

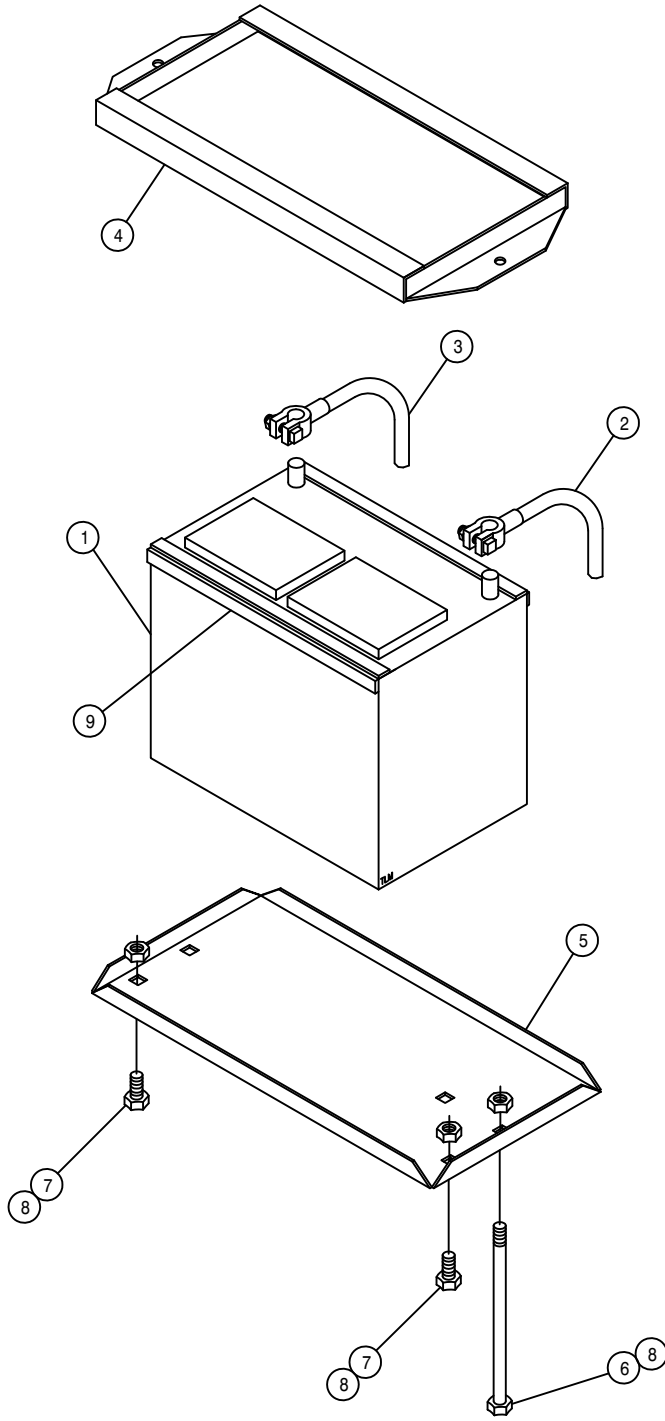

BATTERY BOX ASSEMBLY

DET.	QTY	PART NO.	DESCRIPTION
1	1	291122	BATTERY, 12V 950CCA, SAE POST
2	1	291128	BATTERY CABLE 48 IN
3	1	291530	BATTERY GROUND CABLE, 23"
4	1	341322	BATTERY HOLD DOWN WLD 1981
5	1	361149	BATTERY BOX 8300-8400 1981
6	2	901150	3/8UNC X 9" CARR BOLT
7	2	900129	3/8UNC X 1" HEX BOLT
8	4	914004	3/8UNC HEX STOVER NUT
9	4	193022	STICKERTITE 1/4 X 3/4

CAB ASSEMBLY

DET.	QTY	PART NO.	DESCRIPTION
	1	290107	GROUND CABLE, 8" X 4GA .406LUGS
	2	311051	RUBBER MOUNT, RB3-350
	3	311052	SNUBBING WASHER FOR 311051
	4	24	193037 STICKERTITE 1/8 X 3/4
	5	42	193044 WINDOW WEATHERSTRIP
	6	42	193045 LOCK STRIP FOR 193044
	7	1	290003 WINDSHIELD WASHER NOZZLE KIT
	8	1	291569 3/8 X 6" HEAT SHRINK TUBE
	9	1	200019 .25 SCH 40BP X 1.00 LG C/L
	10	1	202037 WINDSHIELD WIPER SPACER
	11	1	290412 DIMMER SWITCH
	12	1	290417 18" WIPER BLADE
	13	4	900343 5/8UNC X 4 1/2 HEX BOLT
	14	1	343206 CAB WELDMT, 284XP 2002
	15	1	342146 KICK PANEL WLD, 284 CAB 94
	16	1	342150 CAB ROOF WLD, 284 94
	17	1	342180 HEADLINER KPR ANGLE, 284CAB 94
	18	4	470067 GROMMET, .250ID .125GW .375GD
	19	2	470070 GROMMET, .375ID .062GW .500GD
	20	4	914010 5/8UNC HEX STOVER NUT
	21	1	470229 IDENTIFICATION TIE, WHITE
	22	6	470100 3/8 INT TOOTH LOCK WASHER
	23	13	470121 1/4UNC HEX FLANGE LOCK NUT
	24	10	470122 1/4UNC X 1/2 FLANGE HEX BOLT
	25	28	470212 1/4 BONDED SEALING WASH, SS
	26	16	470218 1/4UNC NUT J-TYPE CAGE CLIP
	27	1	470222 GRAB HANDLE, BLACK MOULDED
	28	12	472349 1/4 X 3/4 20THD-IN TEK TYPE
	29	6	473779 10MM-1.50 HEX NUT
	30	2	473910 1/4 X 1 1/2 PHIL HD SHT MTL S
	31	2	650524 OUTSIDE MIRROR W/MTG BRKT
	32	1	658008 WINDSHIELD WIPER MOTOR
	33	1	658013 WIPER ARM
	34	1	658014 FRONT CAB GLASS 94
	35	1	658015 FRONT SIDE CAB/DOOR GLASS 94
	36	2	658016 REAR SIDE CAB GLASS 94
	37	1	658017 REAR CAB GLASS 94
	38	8	900002 1/4UNC X 3/4 HEX BOLT
	39	1	900005 1/4UNC X 1 1/2 HEX BOLT
	40	6	291603 HALOGEN WORKLAMP, SIDE MT 12V
	41	2	903883 10-32 X 1/2 SLT RDHD MACH SCR
	42	2	903889 10-32 X 3/4 SLT RDHD MACH SCR
	43	4	470175 10-32 HEX FLANGE LOCK NUT
	44	14	195913 7/64" WINDSHIELD WASHER HOSE
	45	1	914000 1/4UNC HEX STOVER NUT
	46	1	914004 3/8UNC HEX STOVER NUT
	47	2	342333 NYL HOSE SLEEVE, 2.64ID X 12.00
	48	1	629728 FINISH PLUG FOR 2.12 HOLE
	49	11	470118 1/4UNC X 3/4 FLANGE HEX BOLT
	50	2	659704 FOAM, 2"THK X 2" WIDE X 42"LG

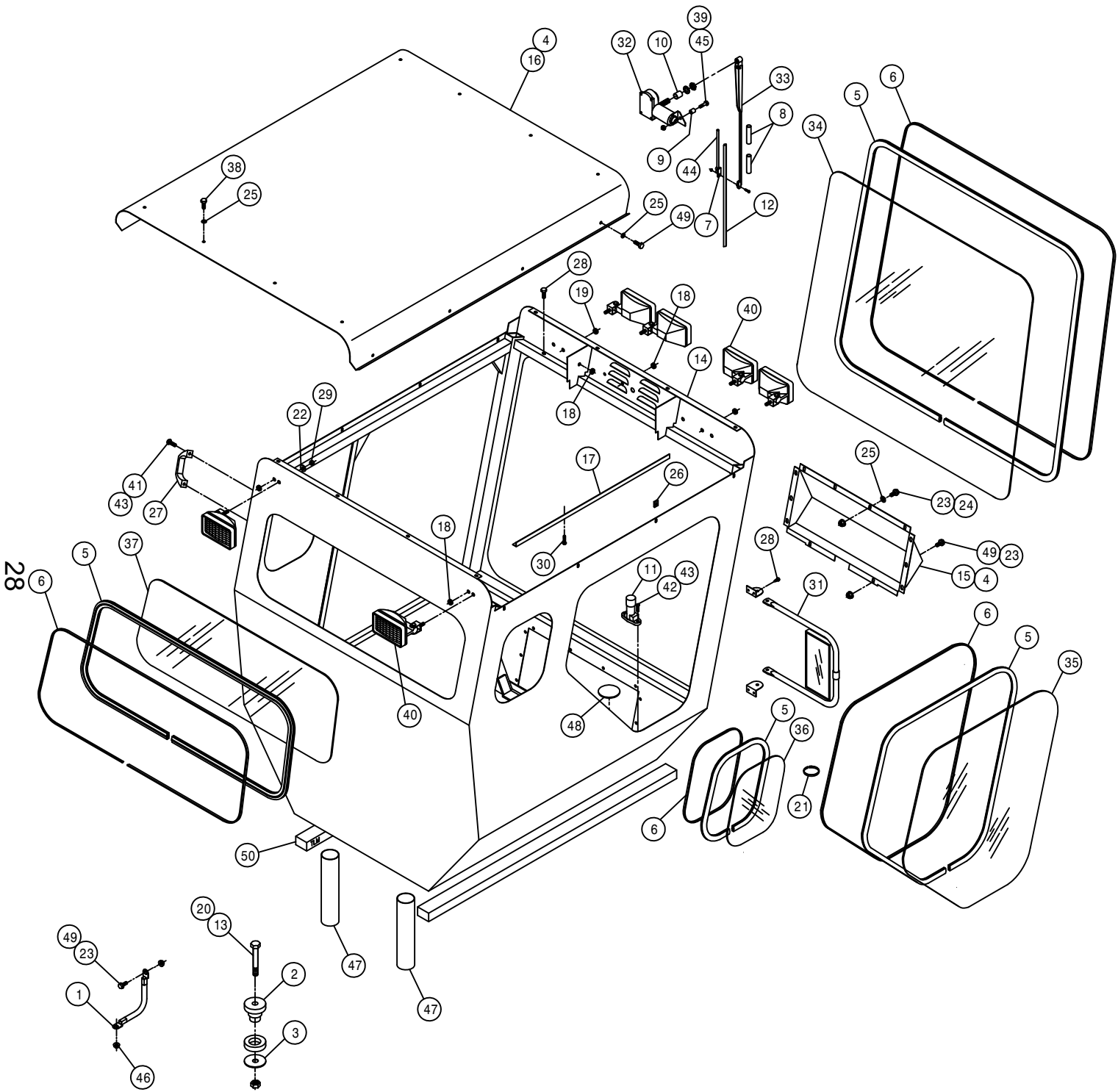

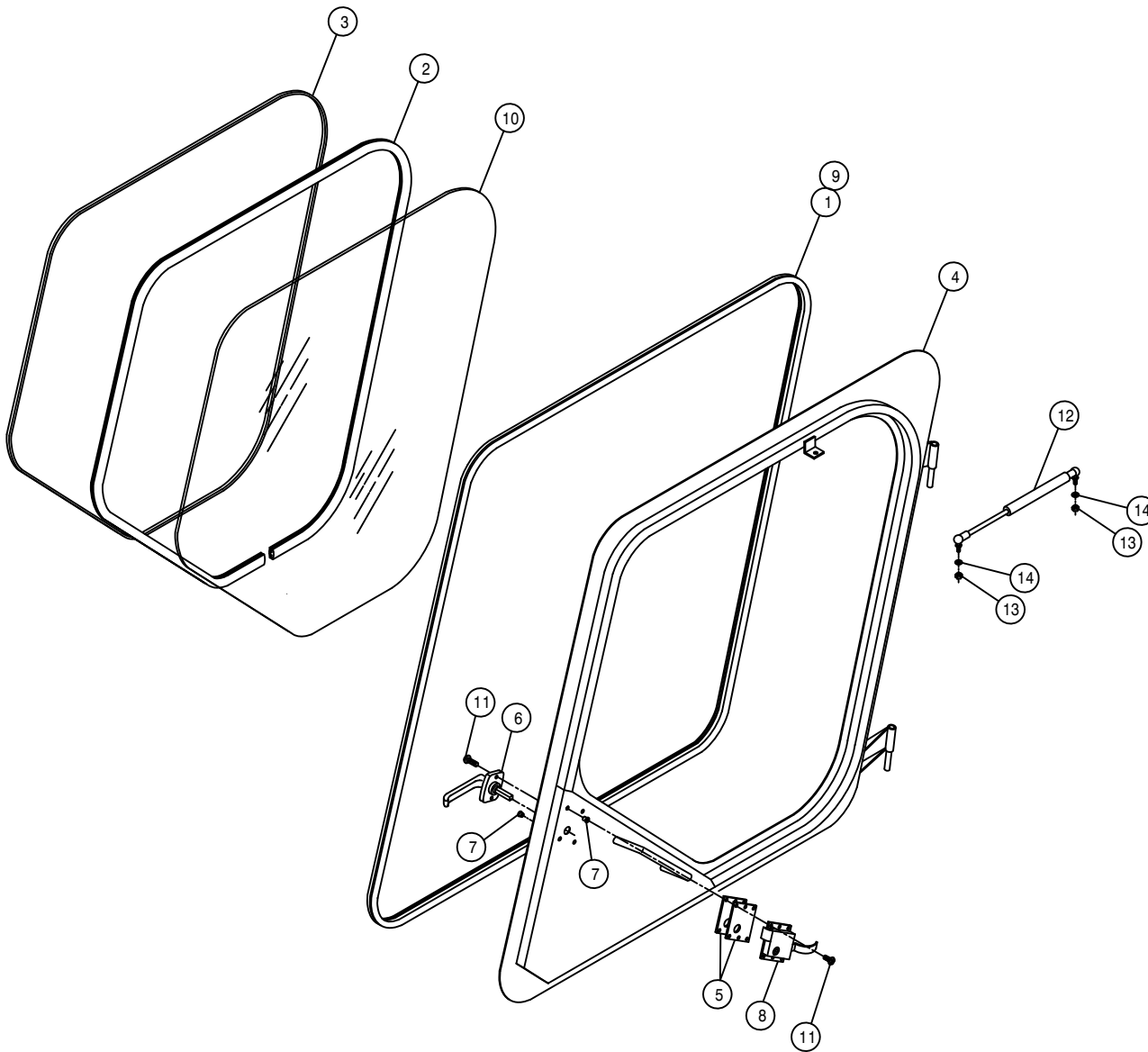

DOOR ASSEMBLY

DET.	QTY	PART NO.	DESCRIPTION
1	12	193028	PUSH-ON TRIM SEAL RS-130-FX
2	9	193044	WINDOW WEATHERSTRIP
3	9	193045	LOCK STRIP FOR 193044
4	1	342153	LH DOOR WLD, 284 CAB 94
5	2	342163	CAB DOOR LATCH SHIM, .06 94
6	1	342217	DOOR HANDLE, 254/284 CAB 94
7	6	470165	10-32 NUTSERT .020-.100 MATL
8	1	470219	CAB LOCK, LH #55
9	2	485052	POP RIVET 1/8 X 3/8
10	1	658015	FRONT SIDE CAB/DOOR GLASS 94
11	6	903710	10-32X5/8 PHIL PANHD MACH SCR
12	1	470221	GAS SPRING, 60LB 3.5 STROKE
13	2	910002	5/16UNC HEX NUT
14	2	920501	5/16 LOCK WASHER

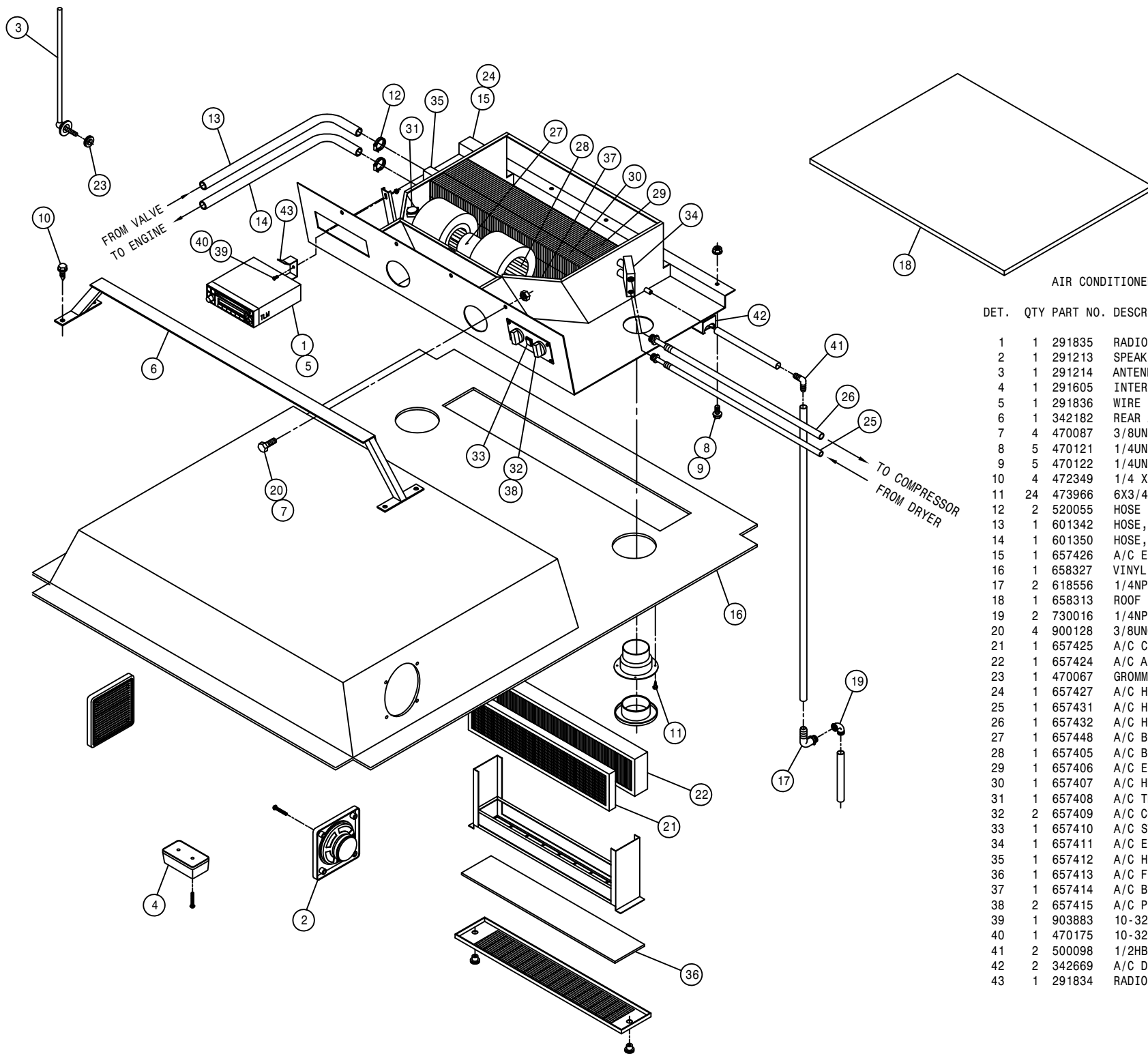

AIR CONDITIONER ASSEMBLY

DET.	QTY	PART NO.	DESCRIPTION
1	1	291835	RADIO, AM/FM/CD/WB CRC-5320
2	1	291213	SPEAKERS (PAIR)
3	1	291214	ANTENNA
4	1	291605	INTERIOR LIGHT W/SWITCH
5	1	291836	WIRE HARNESS FOR 291835 RADIO
6	1	342182	REAR A/C BLOWER MT WLD,CAB 94
7	4	470087	3/8UNC HEX FLANGE LOCK NUT
8	5	470121	1/4UNC HEX FLANGE LOCK NUT
9	5	470122	1/4UNC X 1/2 FLANGE HEX BOLT
10	4	472349	1/4 X 3/4 20THD-IN TEK TYPE
11	24	473966	6X3/4 PHIL FLT HD SHT MTL SCR
12	2	520055	HOSE CLAMP NO 12 STAINLESS
13	1	601342	HOSE, 5/8 X 192 HEATER
14	1	601350	HOSE, 5/8 X 160 HEATER
15	1	657426	A/C EVAPORATOR/HEATER, 284
16	1	658327	VINYL HEAD LINER 99
17	2	618556	1/4NPT-90-1/2 HOSE BARB,POLY
18	1	658313	ROOF SEAL,AIR COND 204,254,284
19	2	730016	1/4NPT ST EL, 90 DEG POLY
20	4	900128	3/8UNC X 3/4 HEX BOLT
21	1	657425	A/C CHARCOAL AIR FILTER
22	1	657424	A/C AIR FILTER
23	1	470067	GROMMET, .250ID .125GW .375GD
24	1	657427	A/C HOSE KIT, EVAP 284, 99
25	1	657431	A/C HOSE ASSY, 5/16 X 173
26	1	657432	A/C HOSE ASSY, 1/2 X 190.
27	1	657448	A/C BLOWER ASSY, 12V KENWAY
28	1	657405	A/C BLOWER WHEEL W/CLIP
29	1	657406	A/C EVAPORATOR COIL
30	1	657407	A/C HEATER COIL
31	1	657408	A/C THERMOSTAT
32	2	657409	A/C CONTROL KNOB
33	1	657410	A/C SWITCH, PUSH ON-OFF
34	1	657411	A/C EXPANSION VALVE
35	1	657412	A/C HEATER VALVE,4-WAY MTRIZED
36	1	657413	A/C FILTER, RECIRCULATION
37	1	657414	A/C BLOWER DRIVE ASSY
38	2	657415	A/C POTENTIOMETER ASSY
39	1	903883	10-32 X 1/2 SLT RDHD MACH SCR
40	1	470175	10-32 HEX FLANGE LOCK NUT
41	2	500098	1/2HB-90-1/2 HOSE BARB, POLY
42	2	342669	A/C DRAIN HOSE KEEPER
43	1	291834	RADIO SUPPORT BRKT

30

300030

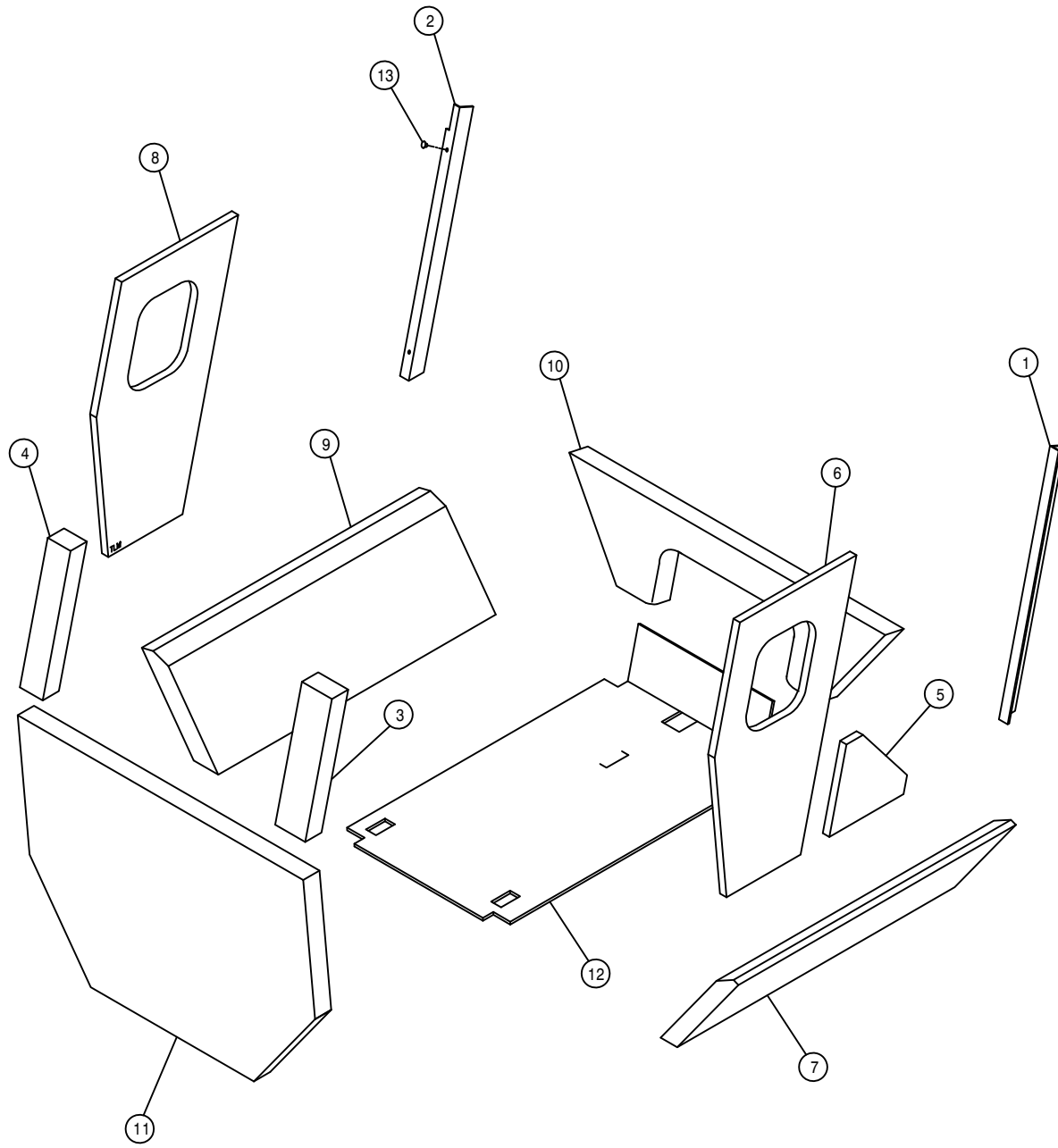

CAB FOAM

DET. QTY PART NO. DESCRIPTION

1	1	658301	VINYL POST COVER, RH FRONT	94
2	1	658302	VINYL POST COVER, LH FRONT	94
3	1	658303	VINYL POST COVER, RH REAR	94
4	1	658304	VINYL POST COVER, LH REAR	94
5	1	658305	VINYL SIDE PANEL, RH	94
6	1	658306	VINYL SIDE PANEL, RH UPPER	94
7	1	658307	VINYL SIDE PANEL, RH LOWER	94
8	1	658308	VINYL SIDE PANEL, LH UPPER	94
9	1	658309	VINYL SIDE PANEL, LH LOWER	94
10	1	658310	VINYL FRONT COVER PANEL	94
11	1	658311	VINYL REAR COVER PANEL	94
12	1	658328	FLOORMAT, 284XP CAB	2002
13	2	470225	TRIM CLIP, 11/16 BLK NYL HEAD	

STEERING POST ASSEMBLY

DET. QTY PART NO. DESCRIPTION

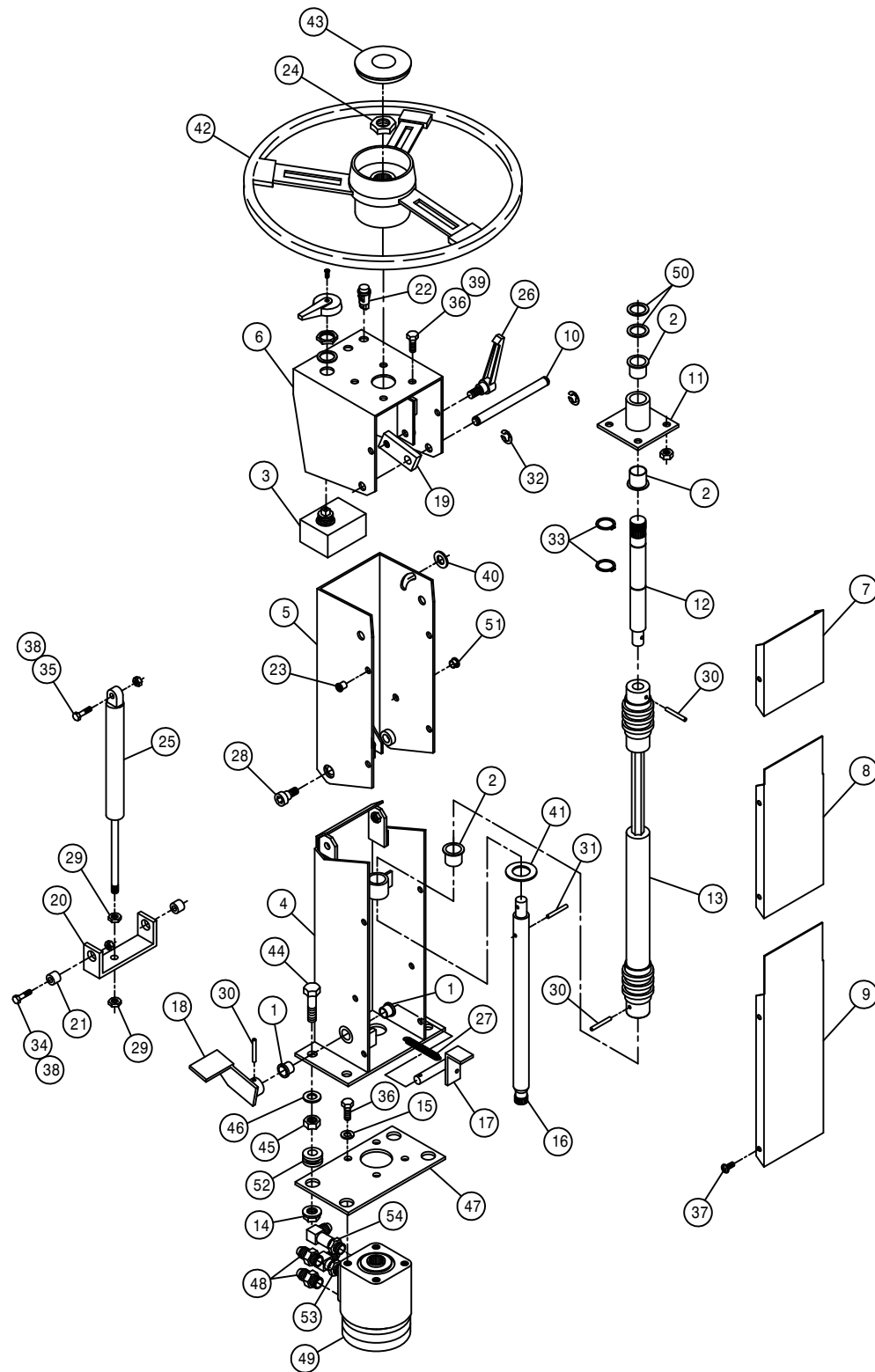

1	2	127502	NYLON FLANGE BRG
2	3	127503	NYLINER FLG BRG, .875 ID
3	1	291088	FLASHER / TURN SIGNAL SWITCH
4	1	342450	LWR STRG COLUMN WLD, 2100 98
5	1	342454	UPPER STRG COLUMN WLD, 2100 98
6	1	342461	STRG WHL MT WLD, 2100 98
7	1	342467	UPPER STRG COLUMN COVER,2100 98
8	1	342468	CNTR STRG COLUMN COVER,2100 98
9	1	342469	LWR STRG COLUMN SHLD
10	1	342470	STRG COLUMN PIVOT PIN, 2100 98
11	1	342471	STRG COL BRG HSG WLD, 2100 98
12	1	342474	UPPER STEERING SHAFT, 2100 98
13	1	470285	DOUBLE UNIVERSAL JOINT DRIVER
14	4	470345P	1/2UNC HEX SMTH FLNG LOCK NUT
15	4	920502	3/8 LOCK WASHER
16	1	342483	LWR STEERING SHAFT, 2100 98
17	1	342484	FOOT PEDAL PIV PIN WLD,2100 98
18	1	342487	FOOT PEDAL WLD, 2100 98
19	1	342490	STRG PIVOT LOCK, 2100 98
20	1	342491	LWR AIR SHOCK PIVOT, 2100 98
21	2	342492	LWR AIR SHOCK PIV BUSH,2100 98
22	2	390318	INDICATOR LIGHT, RED
23	10	470086	1/4UNC NUTSERT .020-.100MATL
24	1	470157	13/16-20UNEF HEX NUT STRG WHL
25	1	470252	GAS SPRING, LOCKING 0350N
26	1	470257	ADJ HANDLE,3/8-16 STUD, BLACK
27	1	470268	SPRING, EXTENSION, .50 X 1.75
28	2	470283	3/8UNC 1/2 SCKT SHLDR BOLT
29	2	473830	10MM-1.00 HEX JAM NUT
30	3	473928	ROLL PIN, 3/16 X 1
31	1	473936	ROLL PIN, 3/16 X 1 1/4
32	2	629525	RING, RETAINING, .50DIA SHAFT
33	2	629533	SNAP RING, 7/8 EXTRN
34	2	900065	5/16UNC X 1" HEX BOLT
35	1	900067	5/16UNC X 1 1/2 HEX BOLT
36	8	900128	3/8UNC X 3/4 HEX BOLT
37	10	903708	1/4UNC X1/2 PHIL PNHD MACHSCR
38	3	914002	5/16UNC HEX STOVER NUT
39	4	914004	3/8UNC HEX STOVER NUT
40	1	920002	3/8 SAE FLAT WASHER
41	1	920007	7/8 SAE FLAT WASHER
42	1	749294	STEERING WHEEL, VIP 14"
43	1	749295	STRG WHL CAP W/HAGIE EMBLEM
44	4	900267P	1/2UNC X 2" HEX BOLT
45	4	470124P	1/2UNC HEX JAM NUT
46	4	920004	1/2 SAE FLAT WASHER
47	1	343211	STEERING MTR PLT,284XP/2100 02
48	2	618109	9/16MJIC-3/4MOR ADPTR
49	1	749318	STRG MTR,7.3CID,NON-LOAD 1031
50	2	483031	1 3/8 X 7/8 X 18GA MACH WASHER
51	1	470342	SNAP PLUG, BLK NYL, .375 DIA
52	4	470346	GROMMET, .500ID .250GW, .812GD
53	1	618115	9/16MJIC-90-3/4MOR LBO
54	1	618709	9/16MJIC-90-3/4MOR EX LG LBO



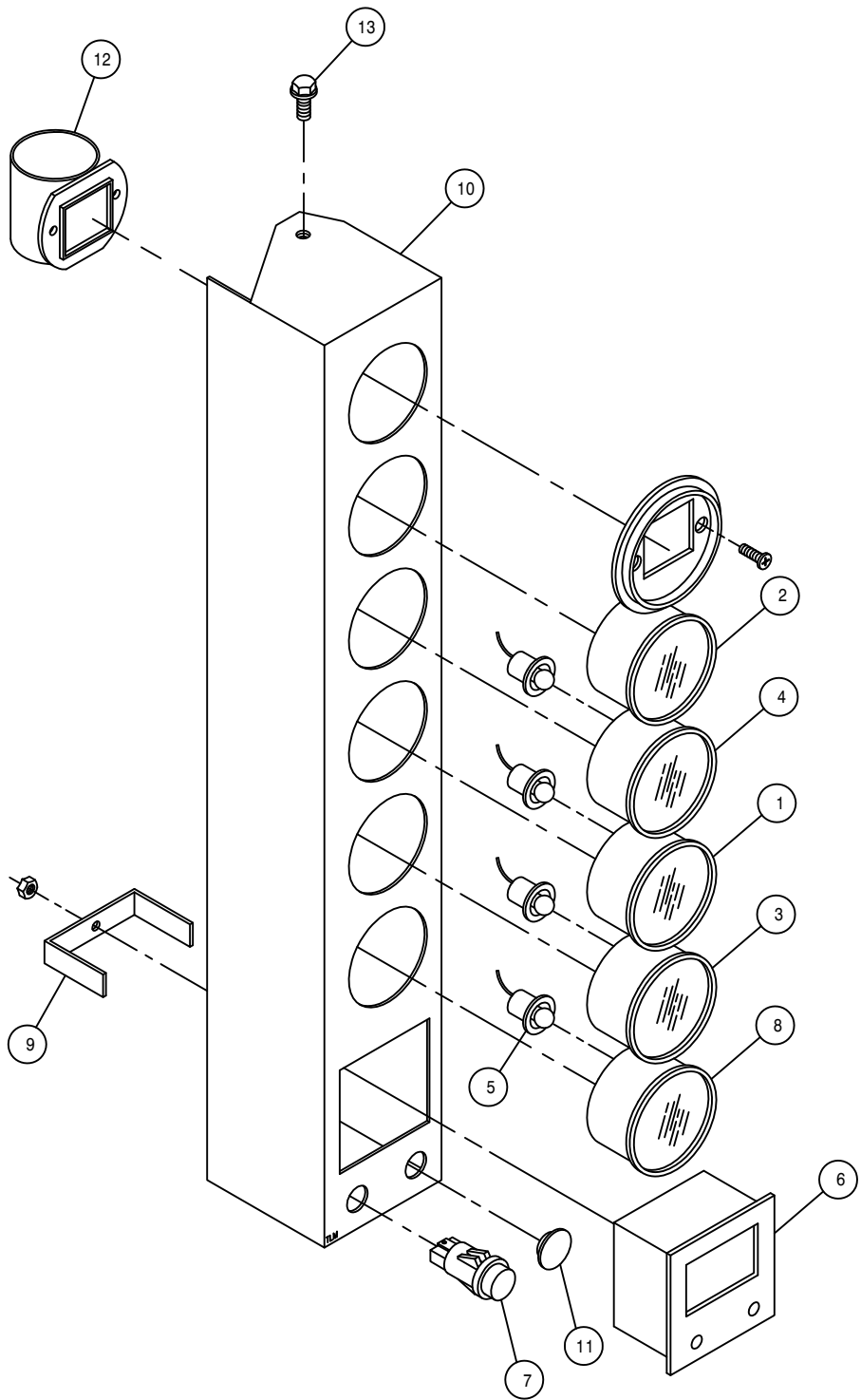

INSTRUMENT PANEL ASSEMBLY

DET.	QTY	PART NO.	DESCRIPTION
	1	290401	FUEL GAUGE FOR 2.125 DIA HOLE
	1	291203	HOUR METER, 12/24VDC BLACK BEZ
	1	291673	OIL PRESS GAUGE,125PSI
	1	291611	VOLTMETER, 8V TO 18V DC
	4	291612	LIGHT KIT FOR 2" GAUGE
	1	291635	DIGITAL MPH/RPM INDICATOR
	1	291638	INDICATOR LIGHT, GREEN
	1	314436	TEMP GA 100-280 DEG LIGHTED
	1	342068	DIGITAL MPH/RPM IND KEEPER 94
	1	342186	INSTRU HSNG WLD, 284 CAB 94
	1	658174	RUBBER BUMPER,1.0000D .500GD
	1	314901	FILTER MINDER AIR RESTRICT GA
	2	470122	1/4UNC X 1/2 FLANGE HEX BOLT

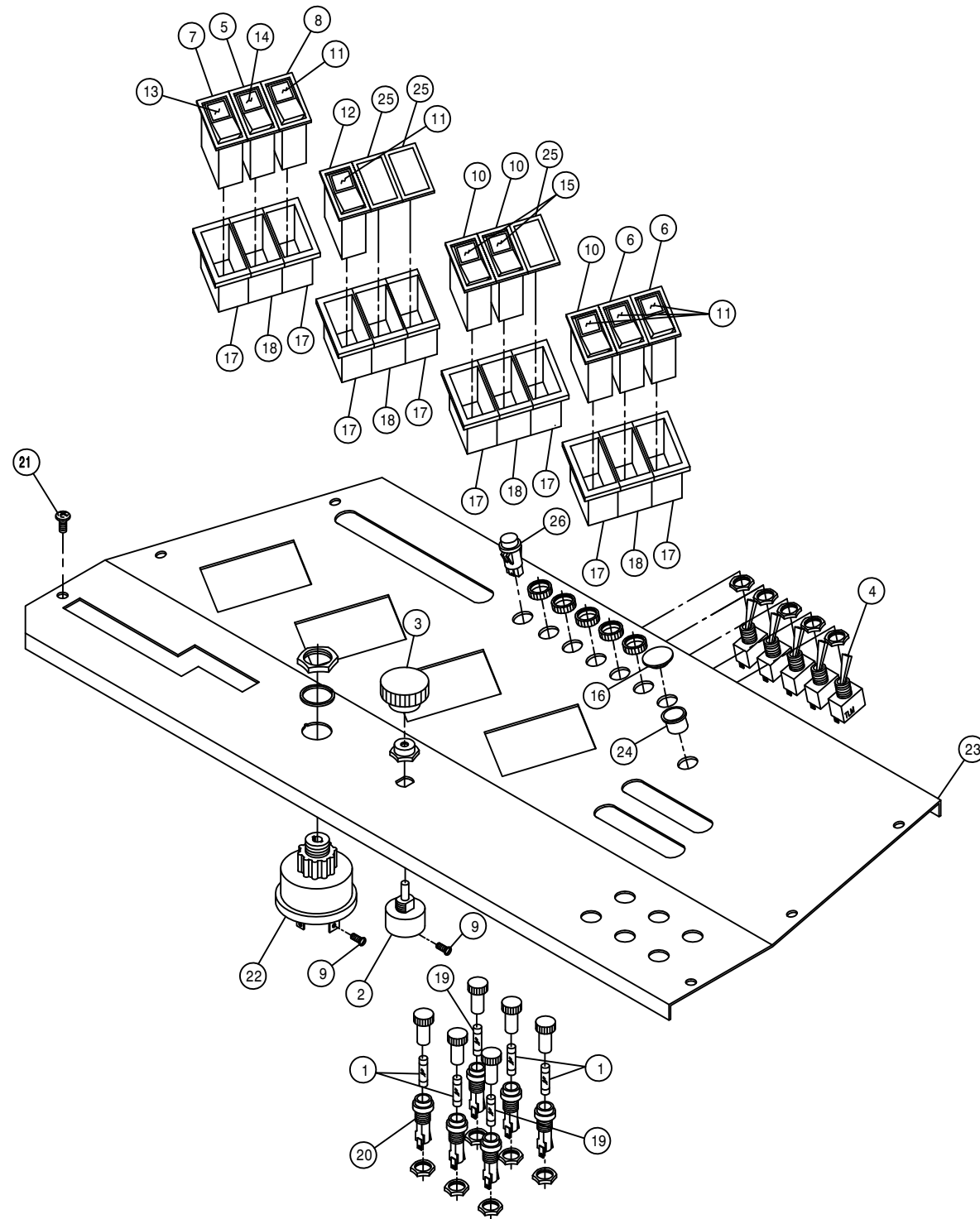

CONSOLE PANEL ASSEMBLY

DET.	QTY	PART NO.	DESCRIPTION
	4	291602	FUSE 10 AMP
	1	291606	ROTARY HEADLAMP SWITCH
	1	291607	SWITCH KNOB FOR 291606
	5	291608	TOGGLE SWITCH, ON-OFF, UNLIT
	1	291622	SWITCH, 1P ON/OFF 511-003
	2	291623	SWITCH, 2P ON/OFF 511-015
	1	291678	SWITCH, 511-115
	1	291625	SWITCH, 2P ON/ON 511-108
	2	903844	8-32 X 1/2 SLT RD HD MACH SCR
	3	291627	SWITCH, 2P (ON)OFF (ON) 511-058
	5	291628	LENS, GREEN 596-650
	1	291671	SWITCH, 2P OFF/ONA/ONAB 511-138
	1	291630	LENS, WINDSHIELD WASHER, 594-701
	1	291631	LENS, HAZARD 595-417
	2	291632	LENS, DIRECTION INDICATOR
	1	658174	RUBBER BUMPER, 1.0000D .500GD
	8	293246	END BEZEL, 594-802
	4	293247	CENTER BEZEL, 594-801
	2	298004	20 AMP FUSE SFE 20
	6	298011	FUSE HOLDER
	6	903708	1/4UNC X1/2 PHIL PNHD MACHSCR
	1	321021	IGN SWITCH, NON-SEALED
	1	342657	CONSOLE COVER PNL, 284 CUMM 99
	1	470223	SNAP BUSHING, BLK NYL, .50DIA
	3	291776	BLANK COVER, 596-273
	1	390318	INDICATOR LIGHT, RED

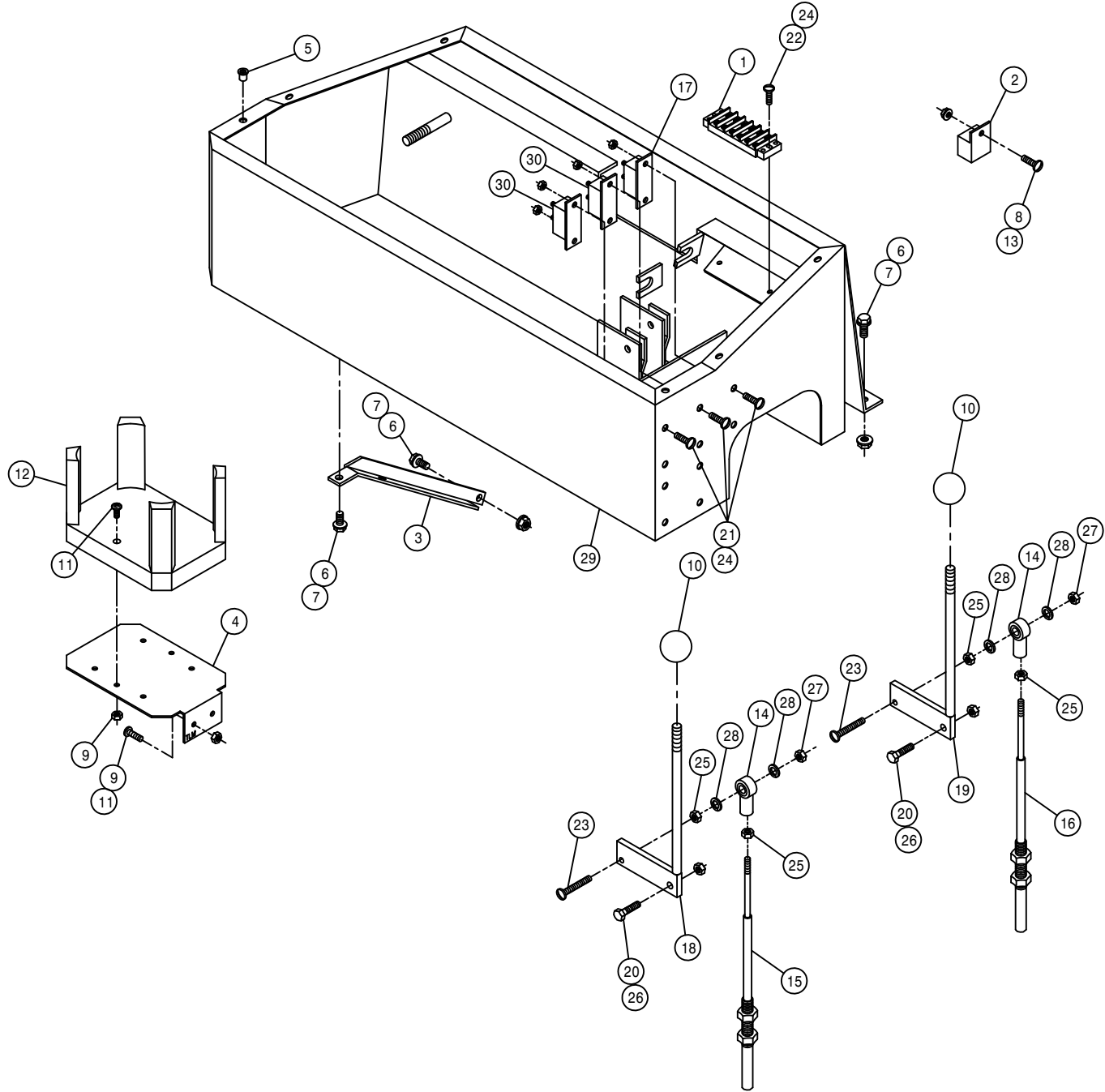

CONSOLE ASSEMBLY

DET.	QTY	PART NO.	DESCRIPTION
	1	293093	TERMINAL BLOCK 6 POS - 2 ROW
	1	291640	RELAY, 12V 20/30AMP BOSCH
	1	342282	CONSOLE BRACE 254/284 95
	1	342216	DRINK HOLDER MT BRKT 94
	5	470086	1/4UNC NUTSERT .020-.100MATL
	5	470118	1/4UNC X 3/4 FLANGE HEX BOLT
	7	470121	1/4UNC HEX FLANGE LOCK NUT
	8	903844	8-32 X 1/2 SLT RD HD MACH SCR
	9	470175	10-32 HEX FLANGE LOCK NUT
	10	659291	KNOB, 1" RND, BLK, 3/8-16
	11	903710	10-32X5/8 PHIL PANHD MACH SCR
	12	470214	SPILLMASTER DRINK HOLDER
	13	910024	8-32 HEX NUT
	14	473921	BALL JOINT NO 10-32 THD
	15	785063	CTRL CABLE 10-32 2IN X 42 LG
	16	785064	CTRL CABLE 10-32 2IN X 53 LG
	17	291024	CIRCUIT BREAKER, 40AMP, INLINEMT
	18	785070	SOLU PRESS CTRL LEVER WLD 94
	19	785073	AGIT CTRL LEVER WLD 94
	20	900003	1/4UNC X 1" HEX BOLT
	21	903812	6-32 X 1/2 SLT RD HD MACH SCR
	22	903814	6-32 X 3/4 SLT RD HD MACH SCR
	23	903893	10-32 X 1" SLT RD HD MACH SCR
	24	910022	6-32 HEX NUT
	25	910027	10-32 HEX NUT
	26	914000	1/4UNC HEX STOVER NUT
	27	914027	10-32 HEX STOVER NUT
	28	920510	#10 LOCK WASHER
	29	342191	CONSOLE WLD, 284 CAB 94
	30	291197	CIRCUIT BREAKER, 30AMP, INLINEMT

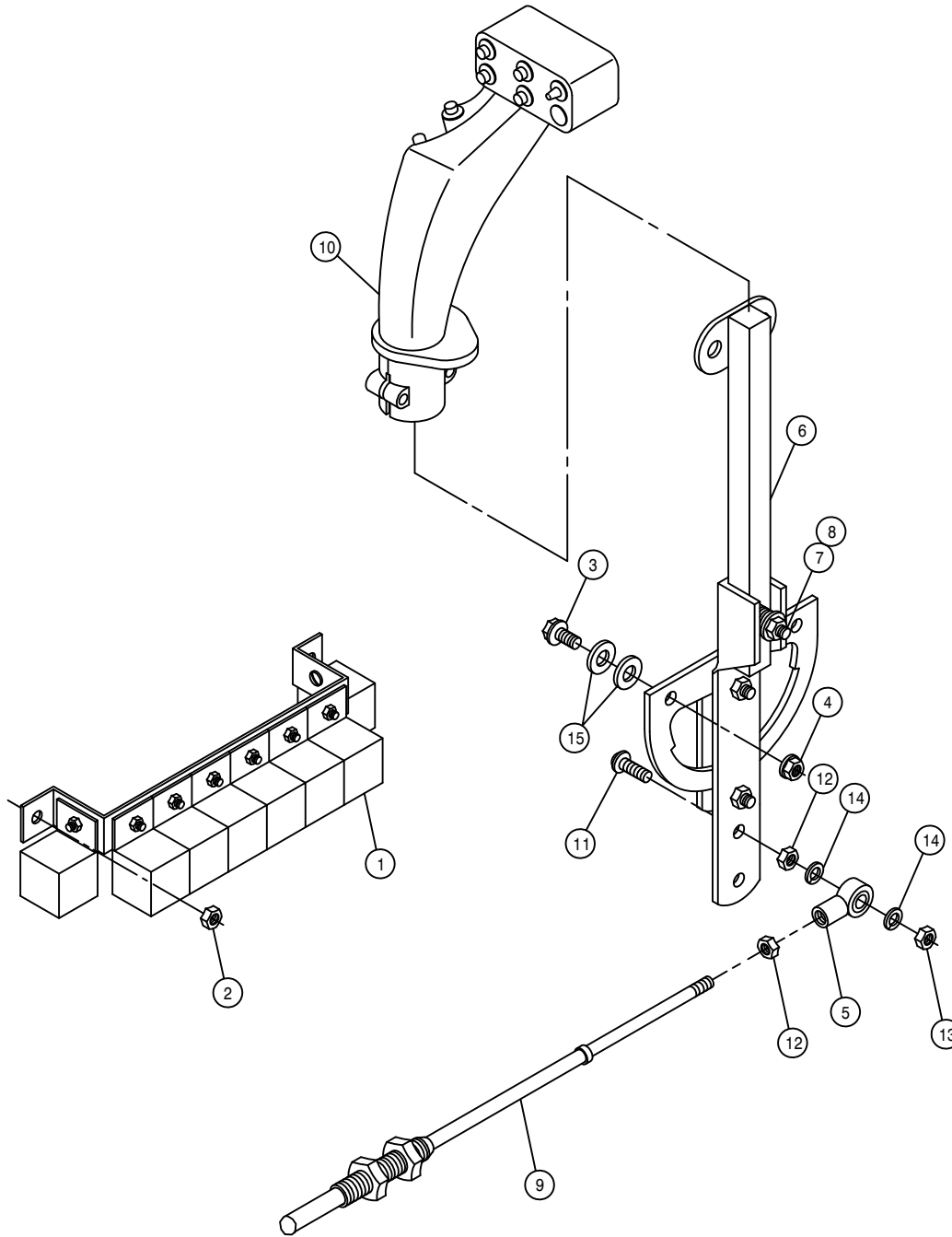

HYDROSTATIC LEVER ASSEMBLY

DET. QTY PART NO. DESCRIPTION

1	8	291640	RELAY, 12V 20/30AMP BOSCH
2	2	470175	10-32 HEX FLANGE LOCK NUT
3	2	470118	1/4UNC X 3/4 FLANGE HEX BOLT
4	2	470121	1/4UNC HEX FLANGE LOCK NUT
5	1	473921	BALL JOINT NO 10-32 THD
6	1	606907	HYDST CTRL LEVER ASSY 204-284
7	1	900005	1/4UNC X 1 1/2 HEX BOLT
8	1	914000	1/4UNC HEX STOVER NUT
9	1	785003	CTRL CABLE 10-32 4IN X 112 LG
10	1	785083	FASSE EZ-3 CTRL HANDLE,284 04
11	1	903893	10-32 X 1" SLT RD HD MACH SCR
12	2	910027	10-32 HEX NUT
13	1	914027	10-32 HEX STOVER NUT
14	2	920510	#10 LOCK WASHER
15	4	920000	1/4 SAE FLAT WASHER

THROTTLE LEVER ASSEMBLY

DET. QTY PART NO. DESCRIPTION

1	1	499001	SPRING HYDRO CONTROL
2	1	785007	KNOB, 1 3/16" BALL, RED, 3/8-16
3	1	785046	FRICTION DISC 3-333 X .38
4	1	785066	CTRL CABLE 10-32 4IN X 129 IN
5	1	785067	THROT LEVER WLD, GAS/DIESEL 94
6	1	903893	10-32 X 1" SLT RD HD MACH SCR
7	2	910027	10-32 HEX NUT
8	1	914004	3/8UNC HEX STOVER NUT
9	1	914027	10-32 HEX STOVER NUT
10	1	920002	3/8 SAE FLAT WASHER
11	2	920510	#10 LOCK WASHER
12	1	473921	BALL JOINT NO 10-32 THD

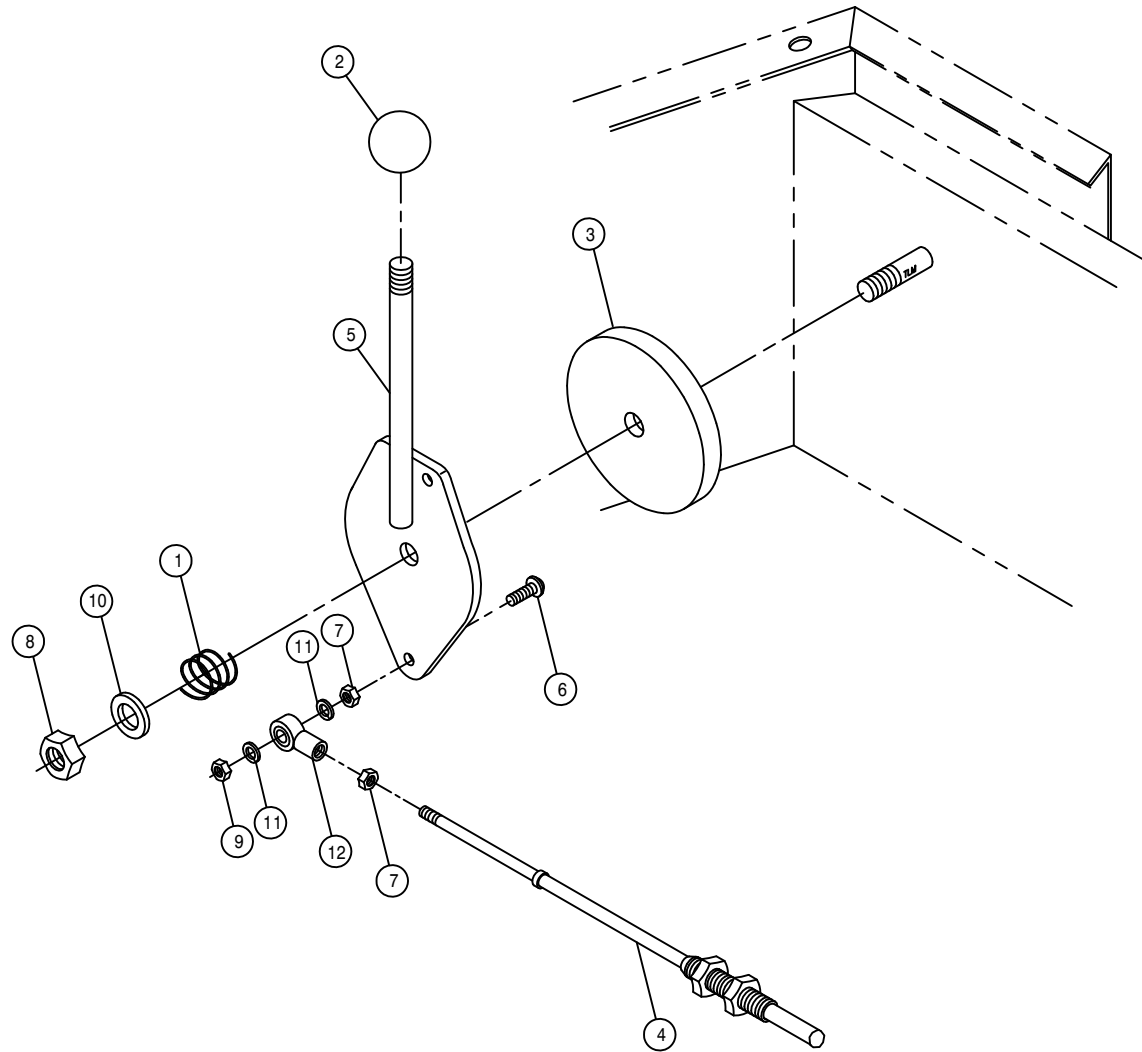

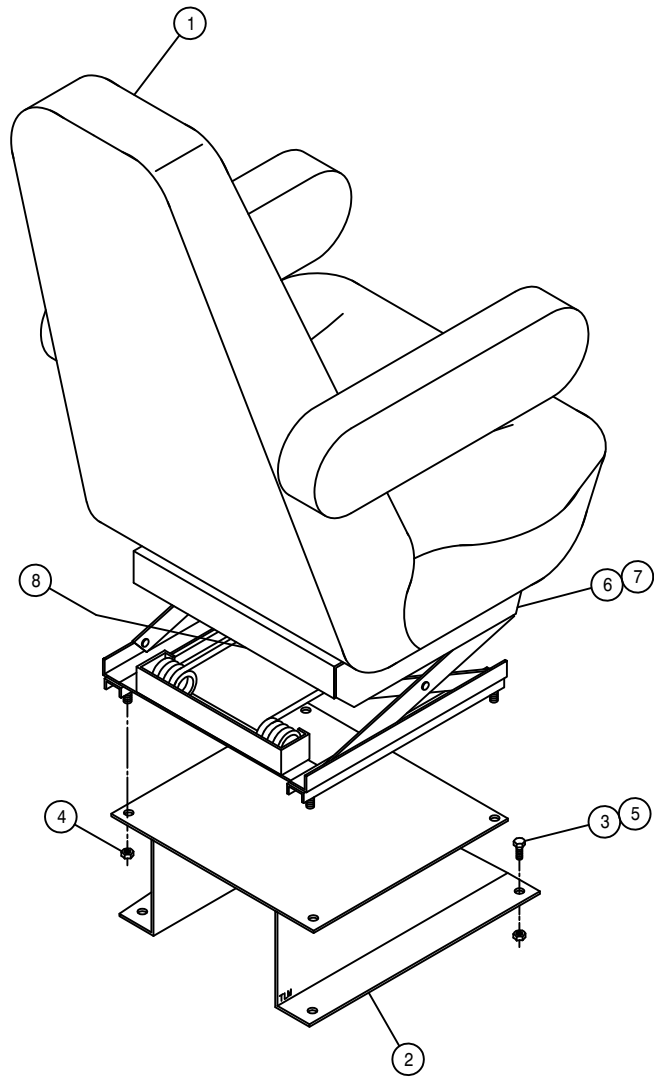

SEAT ASSEMBLY

DET. QTY PART NO. DESCRIPTION

1	1	330022	SEAT, MAGNUM-100 AIR SUSPEND95
2	1	342090	SEAT MT WELD, 254/284 95
3	4	900129	3/8UNC X 1" HEX BOLT
4	4	914002	5/16UNC HEX STOVER NUT
5	4	914004	3/8UNC HEX STOVER NUT
6	1	330024	HEIGHT ADJ LATCH, SEAT 330022
7	1	330025	ADJ LATCH SPRING, SEAT 330022
8	1	330023	AIR BAG PKG, SEAT 330022

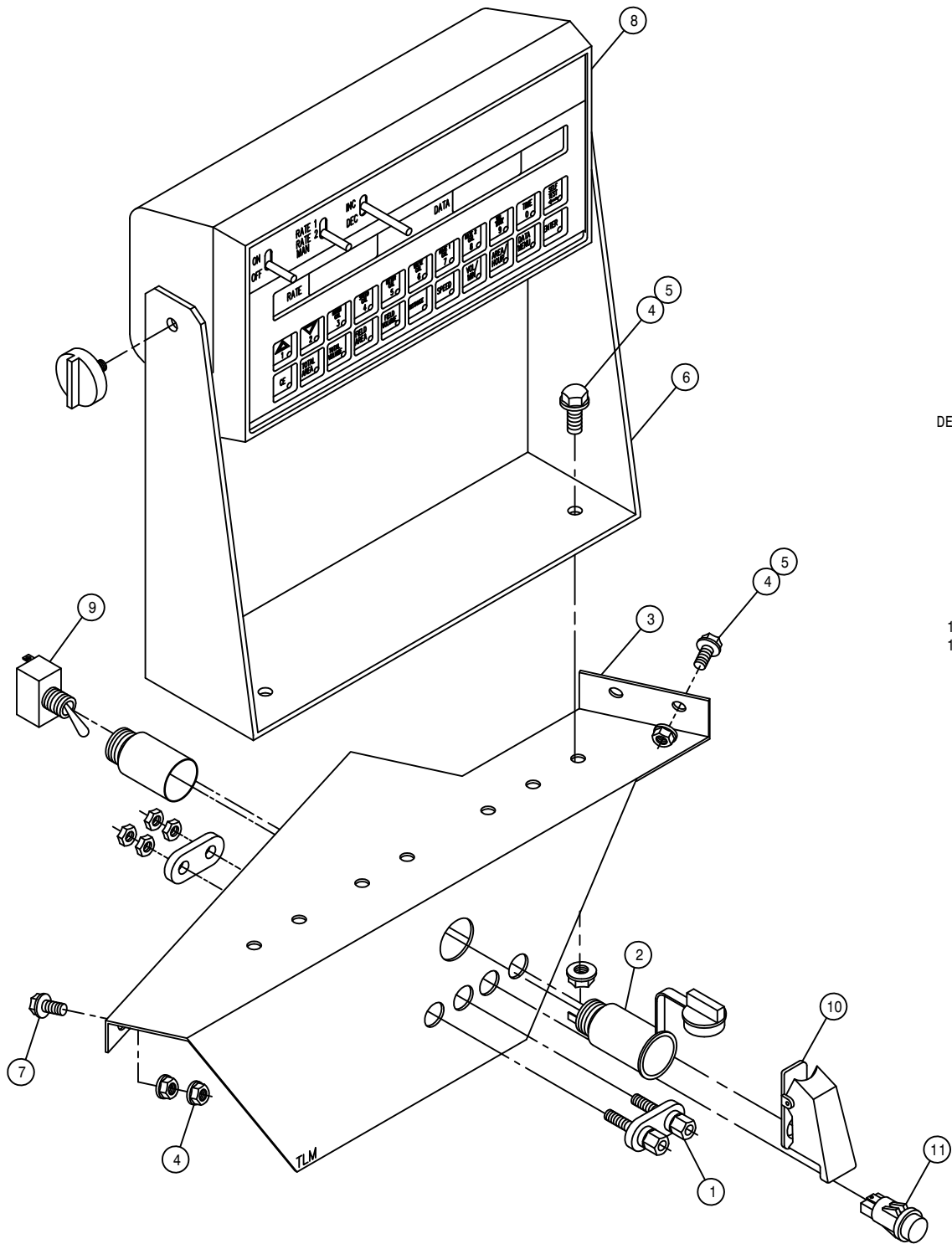

MONITOR MOUNTING BRACKET ASSEMBLY

DET. QTY PART NO. DESCRIPTION

1	1	291647	DUAL BINDING POSTS
2	1	291648	POWER POINT RECEPTACLE
3	1	343201	MONITOR MT, 284XP CAB 2001
4	7	470121	1/4UNC HEX FLANGE LOCK NUT
5	5	470122	1/4UNC X 1/2 FLANGE HEX BOLT
6	1	690498	CONSOLE MT, RAVEN 460 95
7	1	470118	1/4UNC X 3/4 FLANGE HEX BOLT
8	1	690890	CONSOLE, RAVEN 460, SPANISH
9	1	298012	TOGGLE SWITCH, ON-OFF, SPST, 15A
10	1	291655	AIRCRAFT TOGGLE SWITCH GUARD
11	1	390318	INDICATOR LIGHT, RED

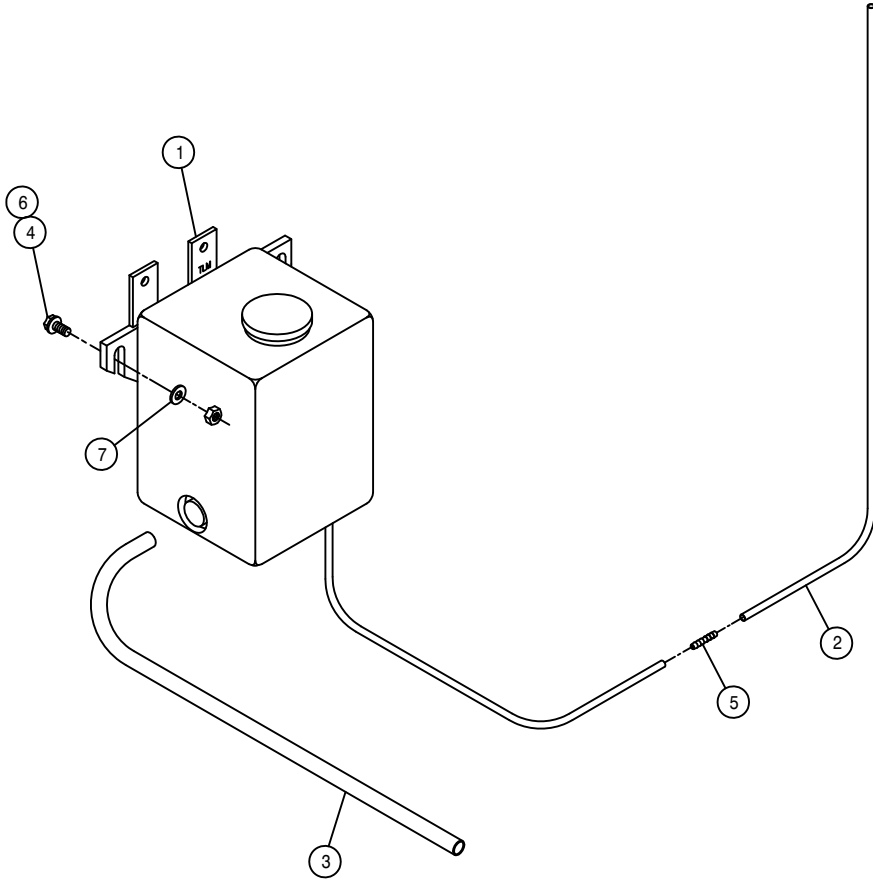

WINDSHIELD WASHER ASSEMBLY

DET. QTY PART NO. DESCRIPTION

1	1	290002	WINDSHIELD WASHER KIT
2	14	195913	7/64" WINDSHIELD WASHER HOSE
3	13	299110	.35 ID WIRE FLEX GUARD
4	3	470231	1/4UNC X 1" FLANGE HEX BOLT
5	1	711033	3/16-1/8 HOSE BARB REDU UNION
6	3	914000	1/4UNC HEX STOVER NUT
7	3	920000	1/4 SAE FLAT WASHER



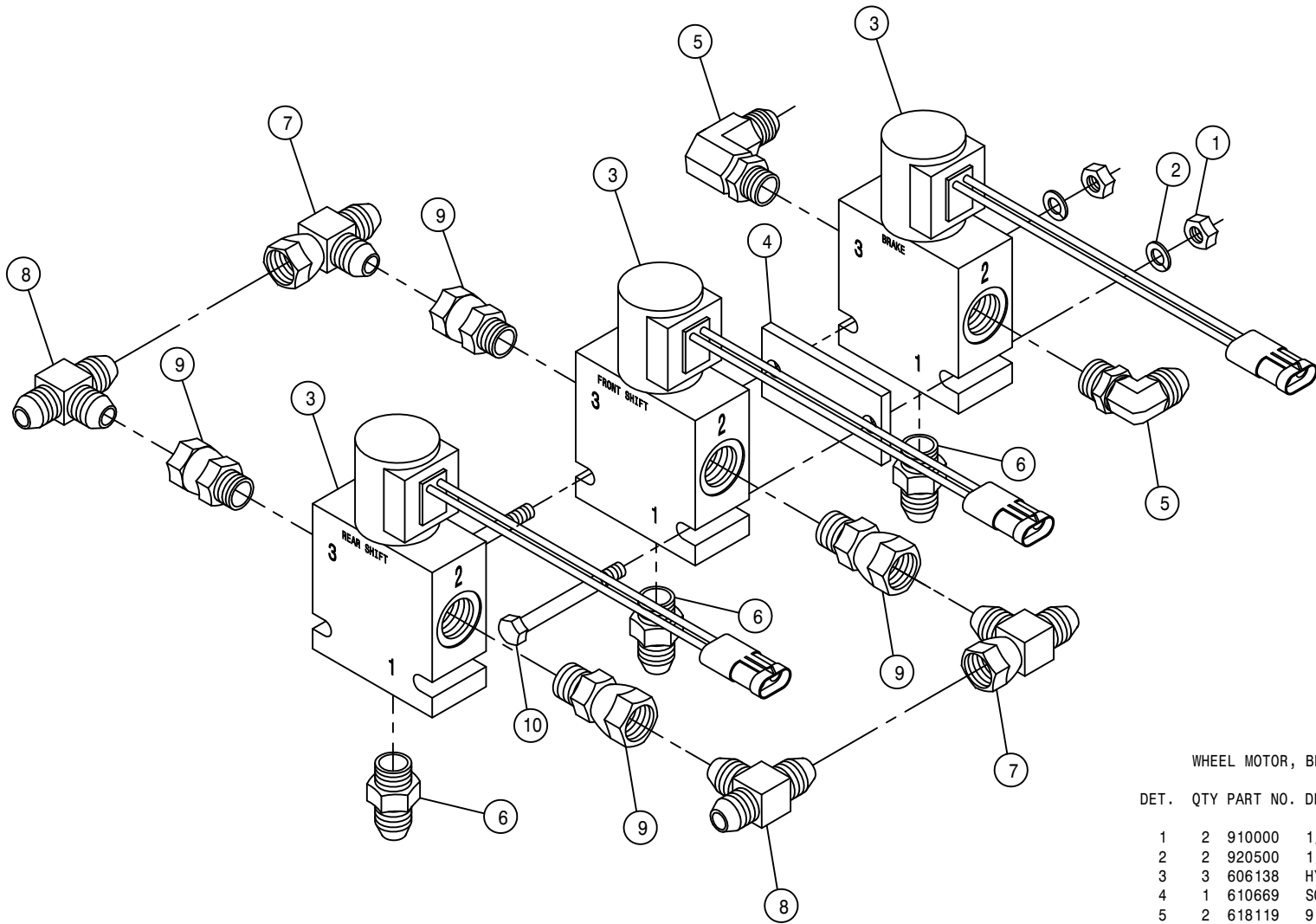

WHEEL MOTOR, BRAKE VALVE ASSEMBLY

DET. QTY PART NO. DESCRIPTION

1	2	910000	1/4UNC HEX NUT
2	2	920500	1/4 LOCK WASHER
3	3	606138	HYD SOLE VLV, 2P-3W, 9/16FOR, WP
4	1	610669	SOLE VLV SPACER
5	2	618119	9/16MJIC-90-9/16MOR LBO
6	3	618126	9/16MJIC-9/16MOR ADPTR
7	2	618486	9/16FJIC SW RUN TEE-9/16MJIC
8	2	618019	9/16MJIC UNION TEE
9	4	618668	9/16FJIC SWIV-9/16MOR ADPTR
10	2	900010	1/4UNC X 3" HEX BOLT

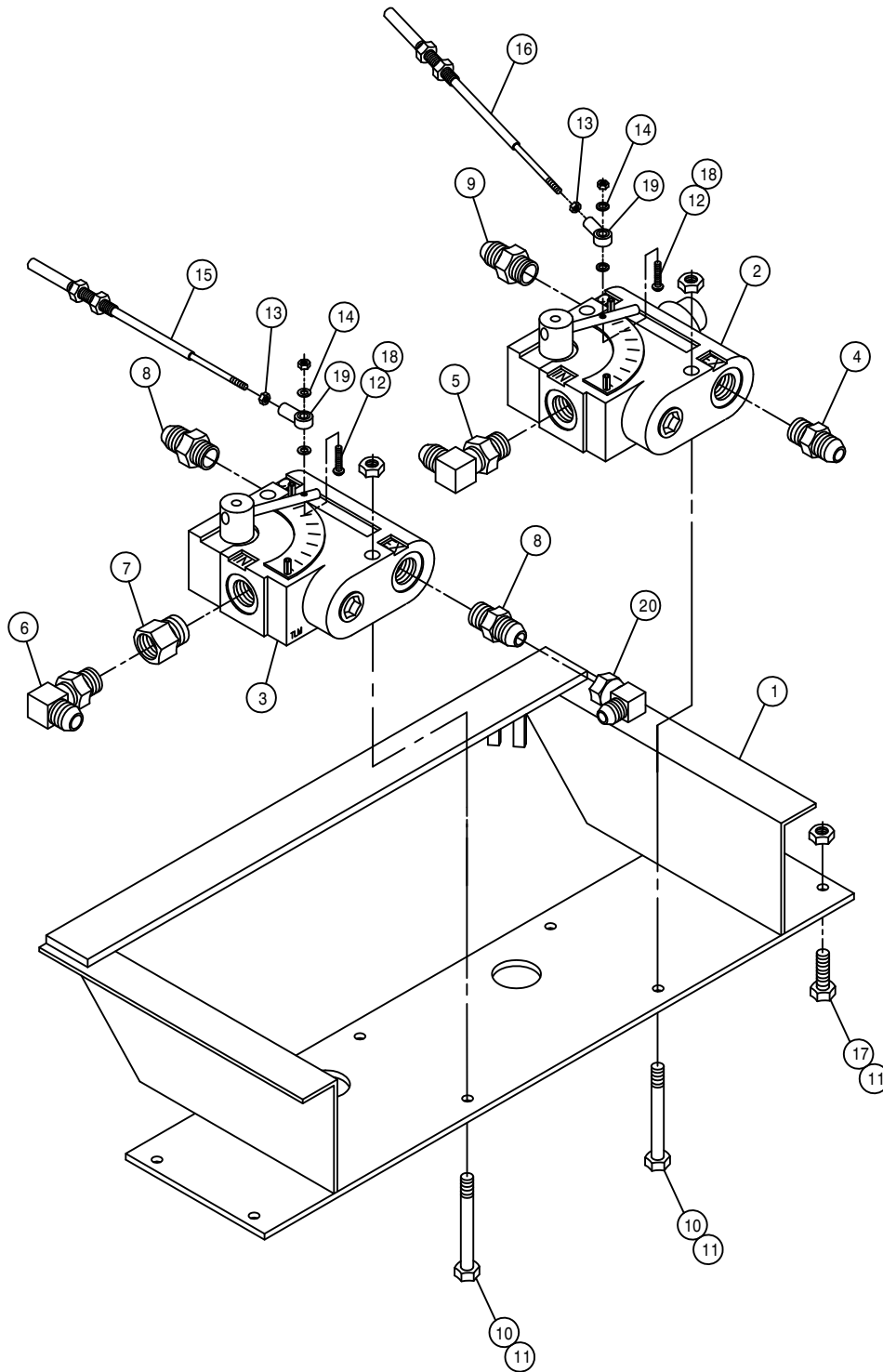

VARIABLE FLOW CONTROL ASSEMBLY

DET.	QTY	PART NO.	DESCRIPTION
			94
1	1	342209	SOLU VFC MT WLD
2	1	606818	FLO CONT FCR51 0-16GPM 7/8FOR
3	1	606827	FLO CONT FC51 0-3 VARI 7/8FOR
4	1	611126	7/8MJIC-7/8MOR ADPTR
5	1	611128	7/8MJIC-90-7/8MOR LBO
6	1	618119	9/16MJIC-90-9/16MOR LBO
7	1	618172	7/8MOR-9/16FOR ADPTR
8	2	618310	9/16MJIC-7/8MOR ADPTR
9	1	618327	3/4MJIC-7/8MOR ADPTR
10	4	900008	1/4UNC X 2 1/2 HEX BOLT
11	8	914000	1/4UNC HEX STOVER NUT
12	2	903893	10-32 X 1" SLT RD HD MACH SCR
13	2	910027	10-32 HEX NUT
14	4	920510	#10 LOCK WASHER
15	1	785064	CTRL CABLE 10-32 2IN X 53 LG
16	1	785063	CTRL CABLE 10-32 2IN X 42 LG
17	4	470118	1/4UNC X 3/4 FLANGE HEX BOLT
18	2	914027	10-32 HEX STOVER NUT
19	2	473921	BALL JOINT NO 10-32 THD
20	1	618618	9/16MJIC-90-9/16FJIC SWIV LBO

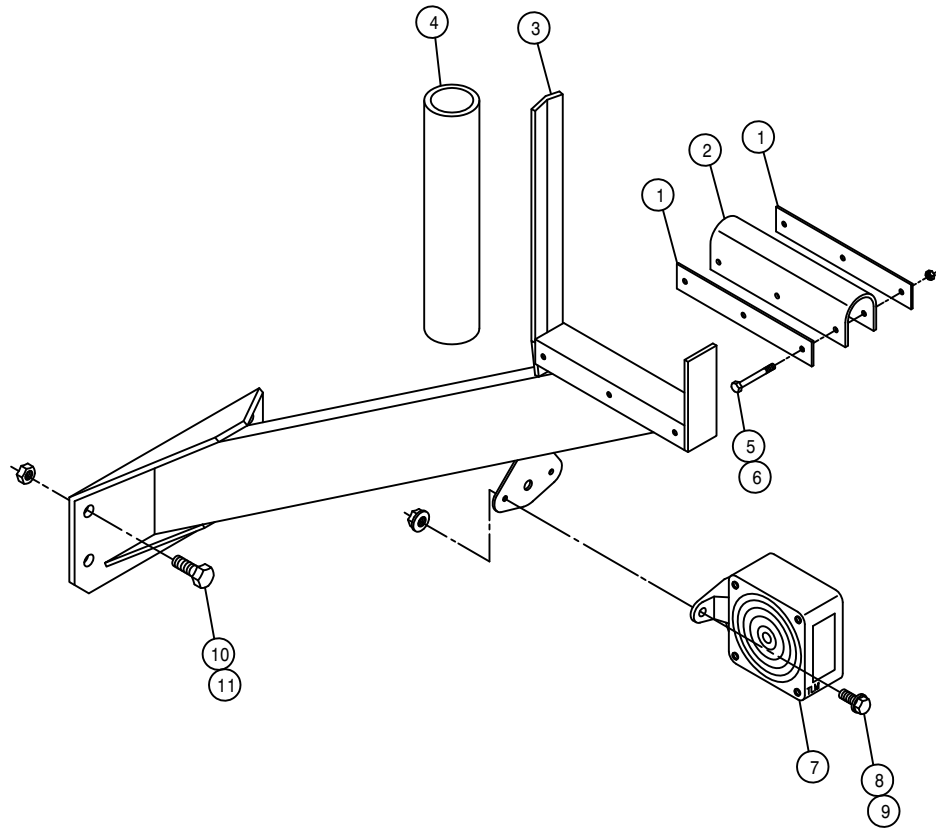

BOOM CRADLE ASSEMBLY

DET. QTY PART NO. DESCRIPTION

1	4	164254	CRADLE CUSHION KEEPER	96
2	2	164256	BOOM CRADLE CUSHION	96
3	2	164746	BOOM CRADLE WLD, 284TXP	03
4	2	601184	HOSE, 1 1/2 X 14 2BR BLK EPDM	
5	6	900010	1/4UNC X 3" HEX BOLT	
6	6	914000	1/4UNC HEX STOVER NUT	
7	2	291604	TURN SIGNAL LIGHT,PED MT, YEL	
8	4	470118	1/4UNC X 3/4 FLANGE HEX BOLT	
9	4	470121	1/4UNC HEX FLANGE LOCK NUT	
10	8	900334	5/8UNC X 1 3/4 HEX BOLT	
11	8	914010	5/8UNC HEX STOVER NUT	

NOTE: QUANTITY LISTED IS FOR ONE MACHINE.

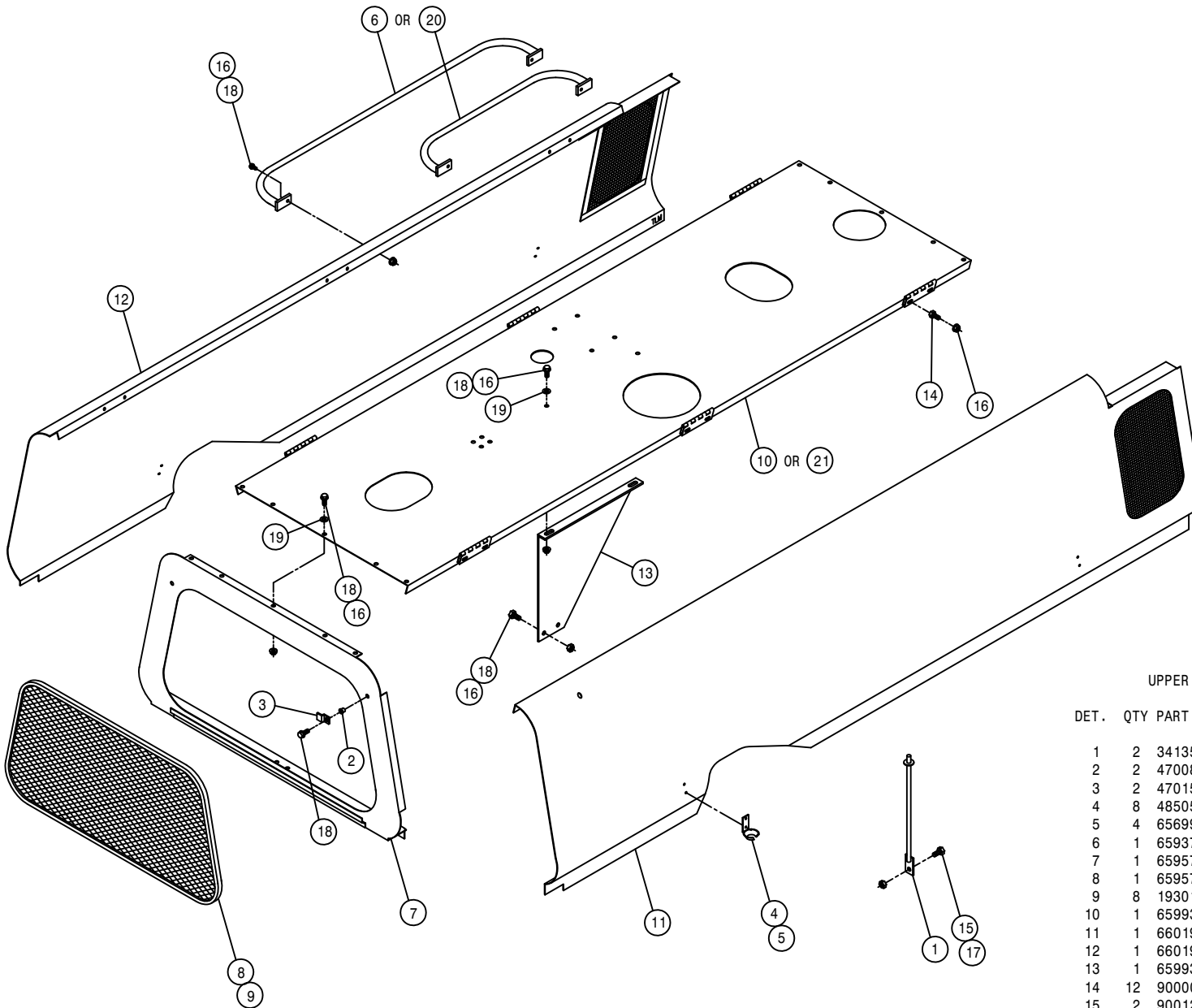

UPPER SHEET METAL ASSEMBLY

DET.	QTY	PART NO.	DESCRIPTION
	1	2	341356 ENGINE HOOD PROP WLD 8240 82
	2	2	470086 1/4UNC NUTSERT .020-.100MATL
	3	2	470151 UPPER REAR PANEL SCREEN CLIP
	4	8	485053 POP RIVET 3/16 X 3/8
	5	4	656997 RUBBER HOOK BRKT
	6	1	659378 RH ENG HOOD HANDRAIL WLD 647S
	7	1	659575 UPPER REAR PANEL WLD 8240 82
	8	1	659578 UPPER REAR PANEL SCREEN 8240
	9	8	193016 QUICKEDGE TRIM .060 TO .170
	10	1	659931 MULLION WLD, 204 CUMM 97
	11	1	660191 RH ENG HOOD WLD 284XP 2001
	12	1	660192 LH ENG HOOD WLD 284XP 2001
	13	1	659930 MULLION SUPPORT BRKT, 284 97
	14	12	900000 1/4UNC X 1/2 HEX BOLT
	15	2	900128 3/8UNC X 3/4 HEX BOLT
	16	28	470121 1/4UNC HEX FLANGE LOCK NUT
	17	2	914004 3/8UNC HEX STOVER NUT
	18	18	470118 1/4UNC X 3/4 FLANGE HEX BOLT
	19	12	470212 1/4 BONDED SEALING WASH, SS
	20	1	660236 ENG HOOD HANDRAIL WLD, 2XX 04
	21	1	660234 MULLION WLD, 204/284 CUMM 04

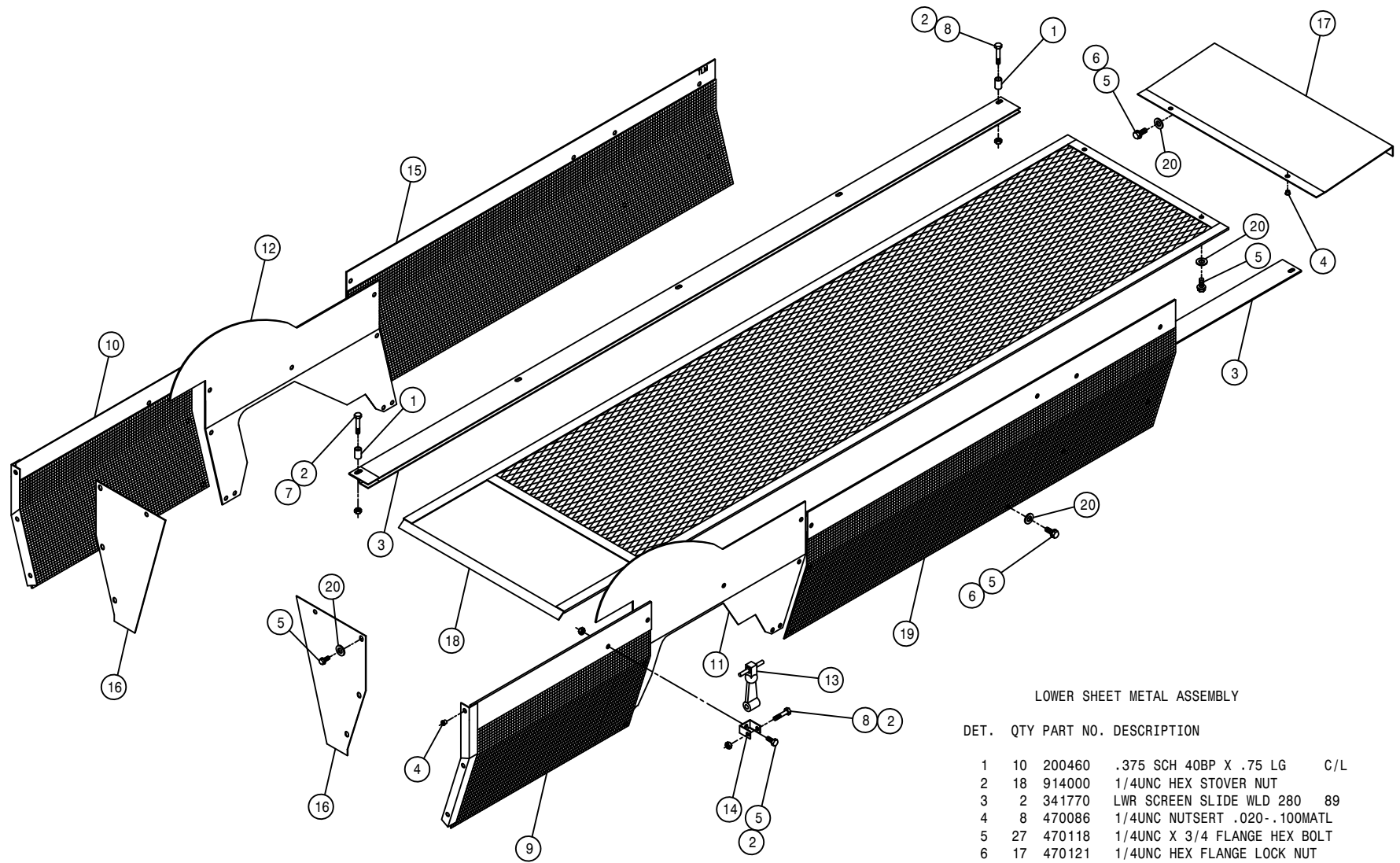

LOWER SHEET METAL ASSEMBLY

DET.	QTY	PART NO.	DESCRIPTION	
1	10	200460	.375 SCH 40BP X .75 LG	C/L
2	18	914000	1/4UNC HEX STOVER NUT	
3	2	341770	LWR SCREEN SLIDE WLD 280	89
4	8	470086	1/4UNC NUTSERT .020-.100MATL	
5	27	470118	1/4UNC X 3/4 FLANGE HEX BOLT	
6	17	470121	1/4UNC HEX FLANGE LOCK NUT	
7	4	900006	1/4UNC X 1 3/4 HEX BOLT	
8	10	900005	1/4UNC X 1 1/2 HEX BOLT	
9	1	659889	RH REAR SIDE SCR N WLD 2XX	92
10	1	659890	LH REAR SIDE SCR N WLD 2XX	92
11	1	660195	RH LWR SIDE SHIELD, 284XP	2001
12	1	660196	LH LWR SIDE SHIELD, 284XP	2001
13	4	656998	RUBBER HOOK	
14	4	656999	RUBBER HOOK ANCHOR BRKT	
15	1	659907	LH FRT SIDE SCR N WLD, 284	94
16	2	660209	LWR REAR PANEL 284TXP	2003
17	1	659803	LWR FRT SHIELD 280	89
18	1	659804	LWR SCREEN WLD 280	89
19	1	659906	RH FRT SIDE SCR N WLD, 284	94
20	29	470212	1/4 BONDED SEALING WASH, SS	

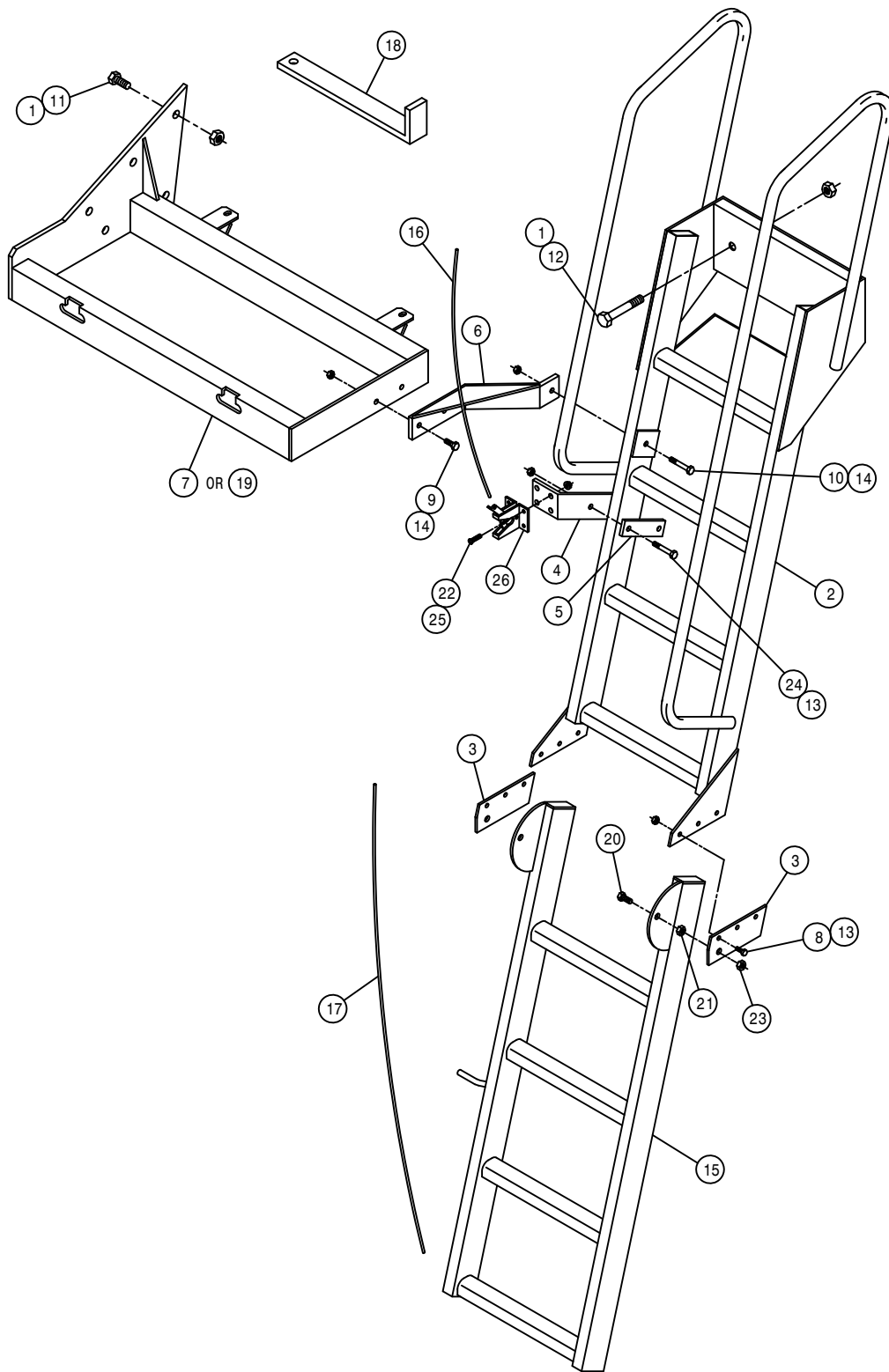

LADDER ASSEMBLY

DET. QTY PART NO. DESCRIPTION

1	14	914010	5/8UNC HEX STOVER NUT	
2	1	342605	LH LADDER WLD, 2100	98
3	2	343279	LADDER EXTEN MT PLT, 284TXP	03
4	1	343280	LADDER LATCH MT, 284TXP	03
5	1	343281	LADDER LATCH MT KEEPER, 284TXP	
6	1	343260	LH LADDER BRACE WLD, 284TXP	03
7	1	760216	LH FUEL TANK MT WLD, 2100	98
8	6	900065	5/16UNC X 1" HEX BOLT	
9	2	900130	3/8UNC X 1 1/4 HEX BOLT	
10	1	900133	3/8UNC X 2" HEX BOLT	
11	12	900334	5/8UNC X 1 3/4 HEX BOLT	
12	2	900829	5/8UNC X 4" HEX BOLT GR8	
13	8	914002	5/16UNC HEX STOVER NUT	
14	3	914004	3/8UNC HEX STOVER NUT	
15	1	343282	LADDER EXTENSION WLD, 284TXP	03
16	1	343288	1/8 X 64" NYLON ROPE	
17	1	343289	3/8 X 136" NYLON ROPE	
18	2	343262	REAR HOSE SUPPORT, 284TXP	03
19	1	760286	RH FUEL TANK MT WLD, 284TXP	03
20	2	900266	1/2UNC X 1 3/4 HEX BOLT	
21	2	910008	1/2UNC HEX NUT	
22	4	903889	10-32 X 3/4 SLT RDHD MACH SCR	
23	2	914008	1/2UNC HEX STOVER NUT	
24	2	900069	5/16UNC X 2" HEX BOLT	
25	4	470175	10-32 HEX FLANGE LOCK NUT	
26	1	470357	GRAVITY DOOR LATCH, FLUSH MT	

FUEL TANK ASSEMBLY

DET. QTY PART NO. DESCRIPTION

1	2	291428	FUEL SENDER 19 IN.	
2	10	473902	NO 8 X 1/2 PAN HD MET SC	
3	2	501102	1/4 PIPE PLUG	
4	8	501451	BLK PIPE EL 90DEG .25NPT	
5	4	501602	BLK PIPE NIPPLE .25NPT-1.50	
6	2	760179	FUEL TANK WLD, 2100	98
7	2	761200	GAS CAP	
8	2	783303	1/4 NPT X 5/16 HOSE BARB, BRS	
9	2	783304	1/4 NPT X 3/8 HOSE BARB, BRS	
10	4	760184	FUEL TANK BAND WLD, 2100	98
11	4	914004	3/8UNC HEX STOVER NUT	
12	14	520120	HOSE CLAMP NO 4 STAINLESS	
13	1	601421	HOSE, 5/16 X 50 FUEL LINE	
14	2	601324	HOSE, 3/8 X 90 FUEL LINE	
15	2	601545	HOSE, 5/16 X 108 FUEL LINE	
16	2	900064	5/16UNC X 3/4 HEX BOLT	
17	2	316281	FUEL STRAINER, IN-LINE, DIESEL	
18	1	601322	HOSE, 3/8 X 26 FUEL LINE	
19	1	610529	FUEL SELECTOR VALVE W/RETURN	
20	2	601528	HOSE, 3/8 X 9 FUEL LINE	

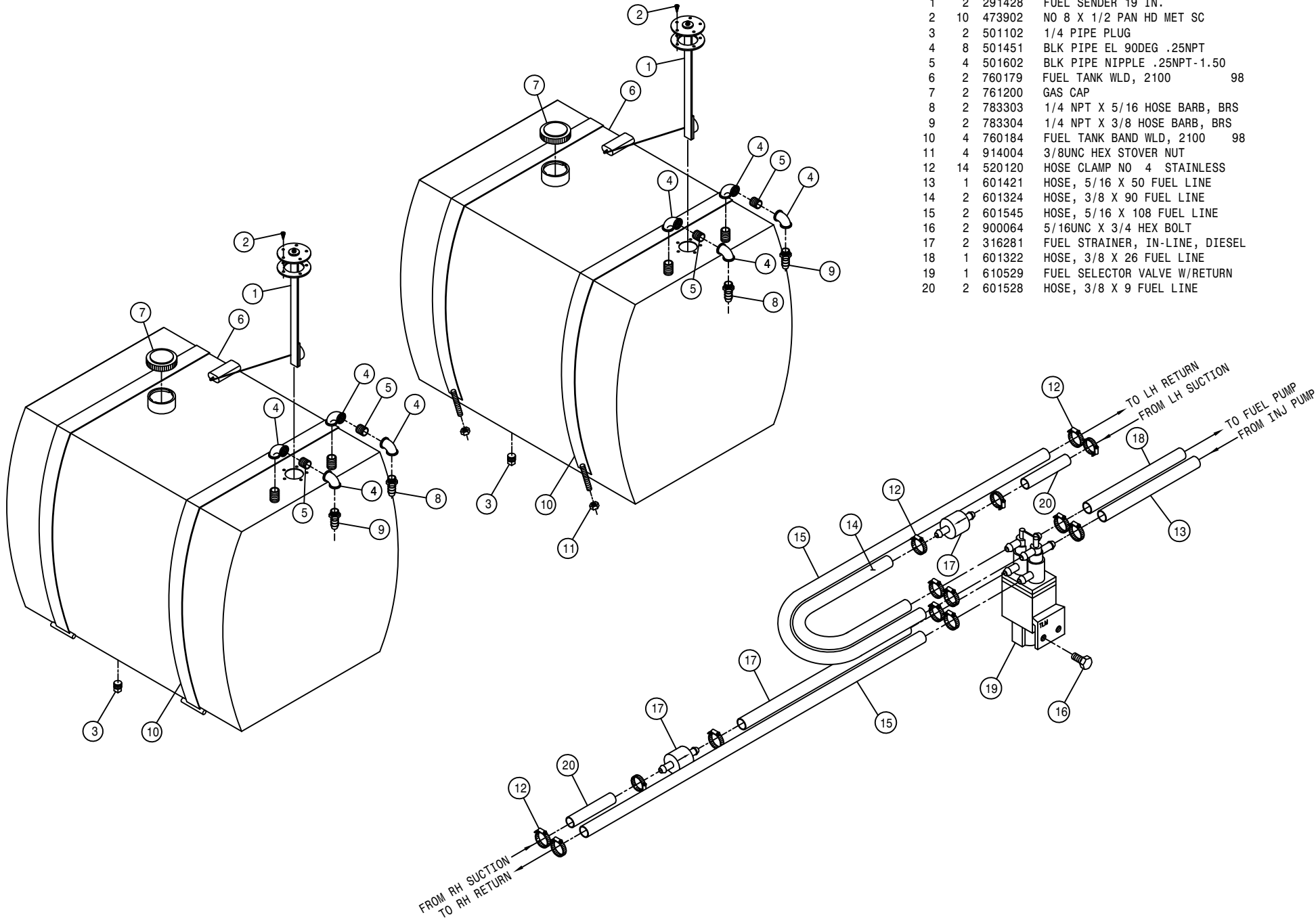

SERVICE PLATFORM ASSEMBLY

DET. QTY PART NO. DESCRIPTION

1	2	291694	RED LAMP, 6 1/2" OVAL 12.8V
2	2	291697	RUBBER MT FOR 6 1/2" OVAL LAMP
3	2	293515	3-WIRE PIGTAIL ASSY
4	1	343265	REAR PLATFORM WLD, 284TXP 03
5	1	342872	RH SERV PLATFORM WLD,284XP 01
6	1	342873	LH SERV PLATFORM WLD,284XP 01
7	1	342875	RH FRT SERV PLTFRM MT WLD XP
8	1	342876	LH FRT SERV PLTFRM MT WLD XP
9	1	342879	RH REAR SERV PLTFRM WLD XP 01
10	1	342880	LH REAR SERV PLTFRM WLD XP 01
11	1	343274	REAR HANDRAIL WLD, 284TXP 03
12	1	342896	LH FRT PLTFRM HANDRAIL WLD XP
13	1	342900	LH REAR PLTFRM HANDRAIL WLD XP
14	1	472251	MTG SOCKET
15	1	472249	SLOW MOVING VEHICLE SIGN
16	1	472250	SPADE MTG BRKT
17	2	470118	1/4UNC X 3/4 FLANGE HEX BOLT
18	2	470121	1/4UNC HEX FLANGE LOCK NUT
19	12	900065	5/16UNC X 1" HEX BOLT
20	4	900071	5/16UNC X 2 3/4 HEX BOLT
21	4	900129	3/8UNC X 1" HEX BOLT
22	6	900334	5/8UNC X 1 3/4 HEX BOLT
23	4	900343	5/8UNC X 4 1/2 HEX BOLT
24	16	914002	5/16UNC HEX STOVER NUT
25	4	914004	3/8UNC HEX STOVER NUT
26	10	914010	5/8UNC HEX STOVER NUT
27	2	920006	3/4 SAE FLAT WASHER
28	2	470162	COTTER PIN 3/16 X 1 1/2 SQCUT

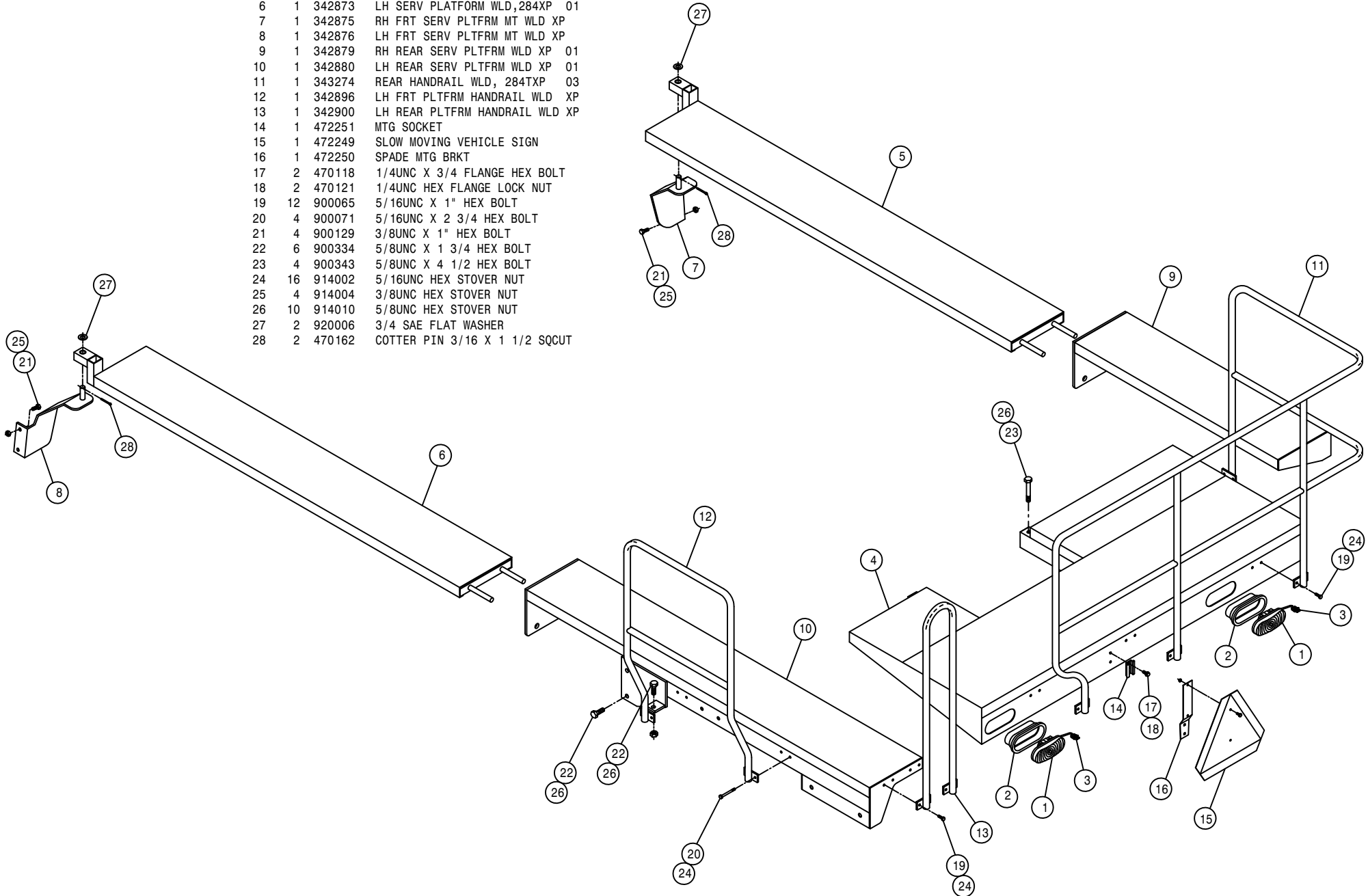

48

300048



SOLUTION TANK MOUNTS AND SHIELDS

DET. QTY PART NO. DESCRIPTION

DET.	QTY	PART NO.	DESCRIPTION
1	4	160621	SPRING TIGHTENER HOOK BUSH
2	12	470118	1/4UNC X 3/4 FLANGE HEX BOLT
3	16	470121	1/4UNC HEX FLANGE LOCK NUT
4	2	358961	LEG BRACE CLEVIS WLD, 2100 99
5	2	359140	LEG BRACE WLD 284XP 2001
6	4	763490	SOLU TANK MT SUPP, 2100 98
7	1	659831	LWR FRONT SHIELD 280 89
8	1	660200	RH FRT POLY TANK SHLD WLD280XP
9	1	660201	LH FRT POLY TANK SHLD WLD280XP
10	1	763580	RH FRT SOLU TANK MT WLD 284XP
11	1	763581	LH FRT SOLU TANK MT WLD 284XP
12	1	763582	RH REAR SOLU TANK MT WLD 284XP
13	1	763583	LH REAR SOLU TANK MT WLD 284XP
14	4	900006	1/4UNC X 1 3/4 HEX BOLT
15	8	920000	1/4 SAE FLAT WASHER
16	2	900410	3/4UNC X 4" HEX BOLT
17	2	900814	1" UNC X 4" HEX BOLT GR8
18	8	900334	5/8UNC X 1 3/4 HEX BOLT
19	8	900412	3/4UNC X 5" HEX BOLT
20	2	910017	1" UNC HEX NUT
21	12	914010	5/8UNC HEX STOVER NUT
22	10	914012	3/4UNC HEX STOVER NUT
23	4	920008	1" SAE FLAT WASHER
24	2	920508	1" LOCK WASHER
25	2	659919	FRT SHIELD EXT, D230 PUMP
26	4	900335	5/8UNC X 2" HEX BOLT
27	12	470212	1/4 BONDED SEALING WASH, SS

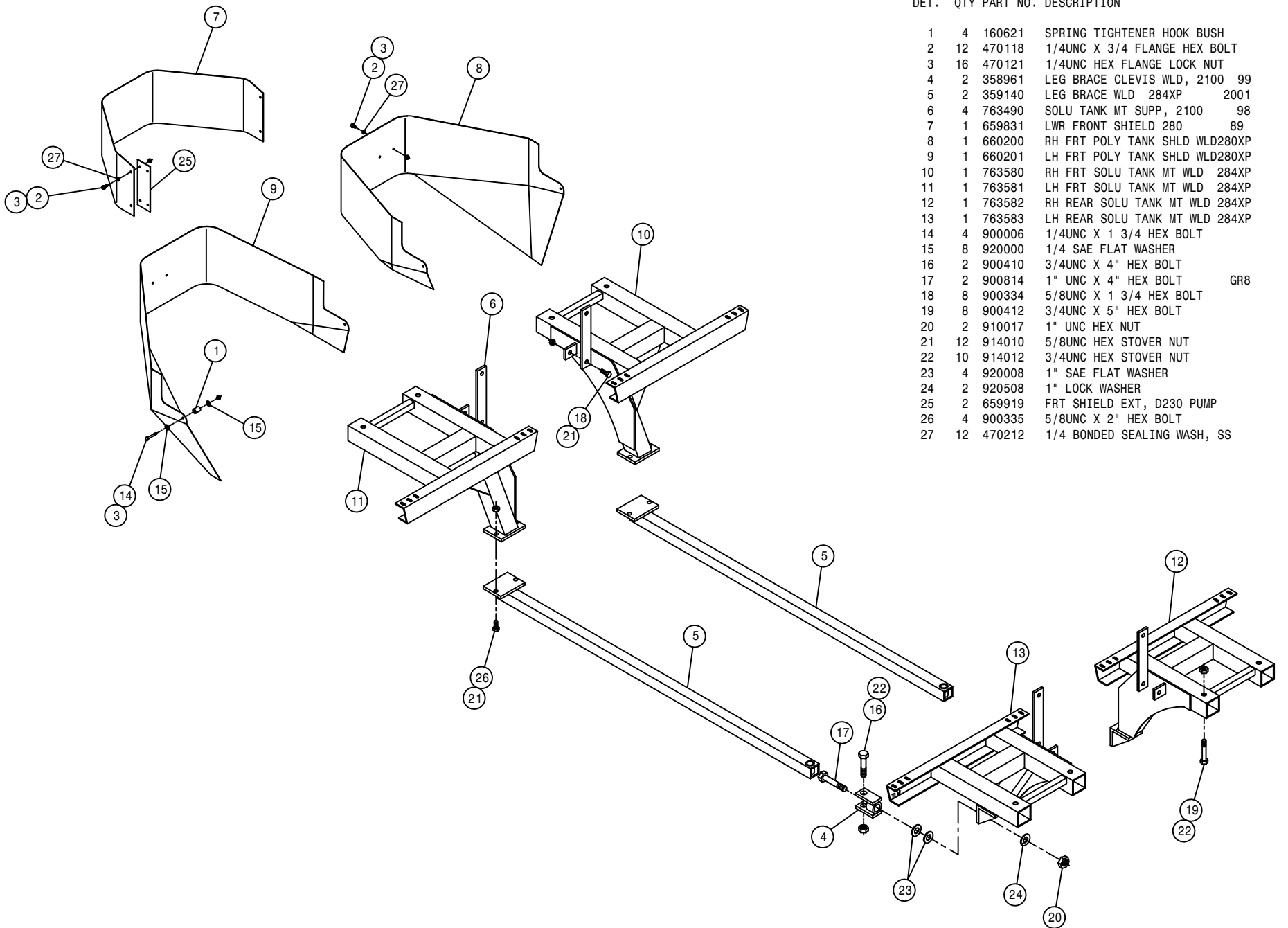

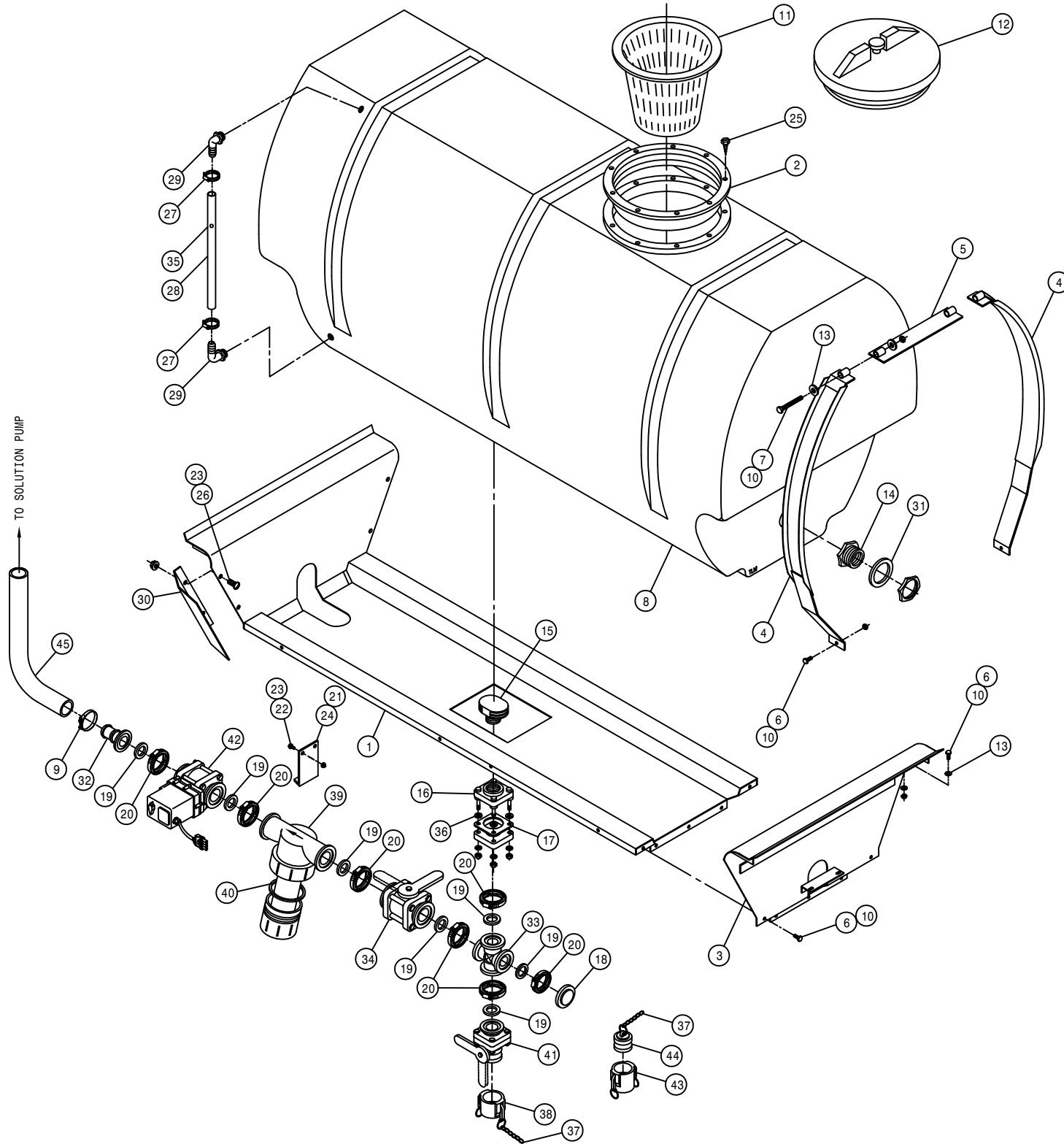

RH POLY 400 GALLON SOLUTION TANK ASSEMBLY

DET.	QTY	PART NO.	DESCRIPTION
	1	763434	POLY TANK CRADLE WELD, 284 94
	2	763409	10" THD'D RING FOR TANK LID
	3	763340	REAR POLY CRADLE MT WLD280 90
	4	763454	TANK BAND WLD, 284 POLY 95
	5	763456	TANK BAND TIE WLD,284 POLY 95
	6	15 900129	3/8UNC X 1" HEX BOLT
	7	6 906138	3/8UNC X 3 1/2 HEX BOLT FULL
	8	1 763440	400 GAL GRAY POLY SOLU TANK 94
	9	1 520133	1.81/2.06 T-BOLT HOSE CLAMP SS
	10	21 914004	3/8UNC HEX STOVER NUT
	11	1 763431	8" STRAINER BASKET, SOLU TANK
	12	1 763408	LID, THD'D W/VENT, POLY TANK
	13	20 920002	3/8 SAE FLAT WASHER
	14	2 618548	1.25 PLASTIC FTG ASSY POLYTNK
	15	1 500077	VENT CAP, 2" W/O SCREEN,POLY
	16	1 500179	2"FLG TANK FTG,BOTDRN BLT POLY
	17	1 500087	GASKET,2" TANK FLG 500076/179
	18	1 500156	2" FLANGE CAP PLUG POLY
	19	7 500158	1 1/2" GASKET FOR 2" FLANGE
	20	7 500160	2" FLANGE CLAMP, S.S.
	21	1 470000	CABLE TIE, 21" BLACK PLASTIC
	22	2 470118	1/4UNC X 3/4 FLANGE HEX BOLT
	23	4 470121	1/4UNC HEX FLANGE LOCK NUT
	24	1 763363	SOLU HOSE SUPPORT 280 POLY 91
	25	8 763410	S.S. SCREW FOR CAP RING
	26	2 472269	1/4UNC X 1/2 TRUSS HD BOLT
	27	2 520069	HOSE CLAMP NO 6 STAINLESS
	28	1 601245	HOSE, 1/2 X 42 CLEAR VINYL
	29	2 618556	1/4NPT-90-1/2 HOSE BARB,POLY
	30	1 763436	RH SIGHT GAGE SHLD,POLY284 94
	31	2 763430	1 1/4 TANK FLANGE RUBBER SEAL
	32	1 500162	2" FLANGE-1 1/2 HOSE BARB POLY
	33	1 500176	2" FLANGE CROSS POLY
	34	1 696142	BALL VLV, 2" FLANGE
	35	1 763446	RED POLYPROPYLENE BALL 25/64"
	36	4 500100	FOOT GASKET,2" FLG 500076/179
	37	2 160986	CHAIN, 12.00 LONG
	38	1 690623	CAP FOR 2.00 MALE COUPLER POLY
	39	1 690628	LINE "Y" STRAINER, 2" FLANGE
	40	1 690629	50 MESH SCREEN FOR 690628
	41	1 696141	BALL VLV,2"FLANGE/2"MALE ADPTR
	42	1 696176	ELECT BALL VLV,2"FLANGE BANJO
	43	1 690390	2.00FNPT-FEMALE COUPLER POLY
	44	1 690392	PLUG FOR 2.00 FEMALE COUPLER
	45	1 601307	HOSE, 1 1/2 X 118 2F-1W EPDM

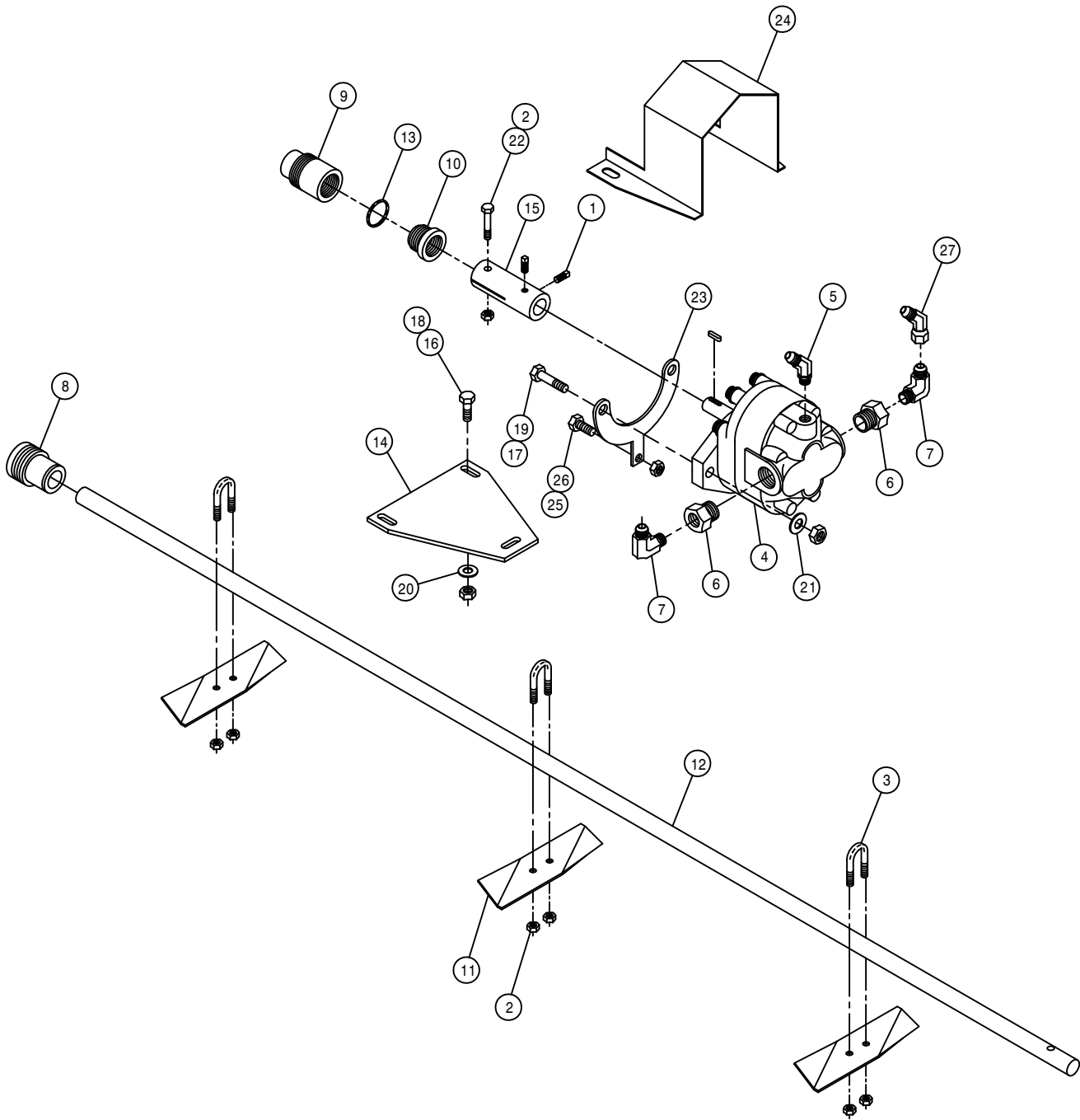

RH POLY TANK AGITATION ASSEMBLY

DET. QTY PART NO. DESCRIPTION

1	2	470199	1/4UNC X 3/8 SQHD CUP SET SCR	
2	7	470089	1/4UNC HEX LOC NUT NYL INS SS	
3	3	470092	1/4UNC-3/4ID-1 1/4 U-BOLT SS	
4	1	610510	CESSNA GEAR MOTOR 1.48CI	
5	1	618338	9/16MJIC-45-1/4MNPT LBO	
6	2	618092	1 1/16MOR-1/2FNPT ADPTR	
7	2	618107	9/16MJIC-90-1/2MNPT LBO	
8	1	706403	FRT AGIT SHFT BRG, NYLON	
9	1	706401	REAR AGIT SHFT BRG, NYLON	
10	1	706402	AGIT SHFT GLAND NUT, NYLON	
11	3	763027	AGIT IMPELLER	
12	1	763360	AGIT SHAFT 280	91
13	1	763217	GLAND PACKING, 13 IN. LONG	
14	1	763357	AGIT MTR MT PLT CES 280	91
15	1	763359	AGIT MTR CPLR 280	91
16	2	900064	5/16UNC X 3/4 HEX BOLT	
17	2	900130	3/8UNC X 1 1/4 HEX BOLT	
18	2	914002	5/16UNC HEX STOVER NUT	
19	2	914004	3/8UNC HEX STOVER NUT	
20	2	920001	5/16 SAE FLAT WASHER	
21	2	920002	3/8 SAE FLAT WASHER	
22	1	470200	1/4UNC X 1 3/4 HEX BOLT SS	
23	1	763358	AGIT MTR MT YOKE CES 280	91
24	1	763361	AGIT CPLR SHIELD 280	91
25	1	900000	1/4UNC X 1/2 HEX BOLT	
26	1	914000	1/4UNC HEX STOVER NUT	
27	1	618634	9/16MJIC-45-9/16FJIC SWIV LBO	

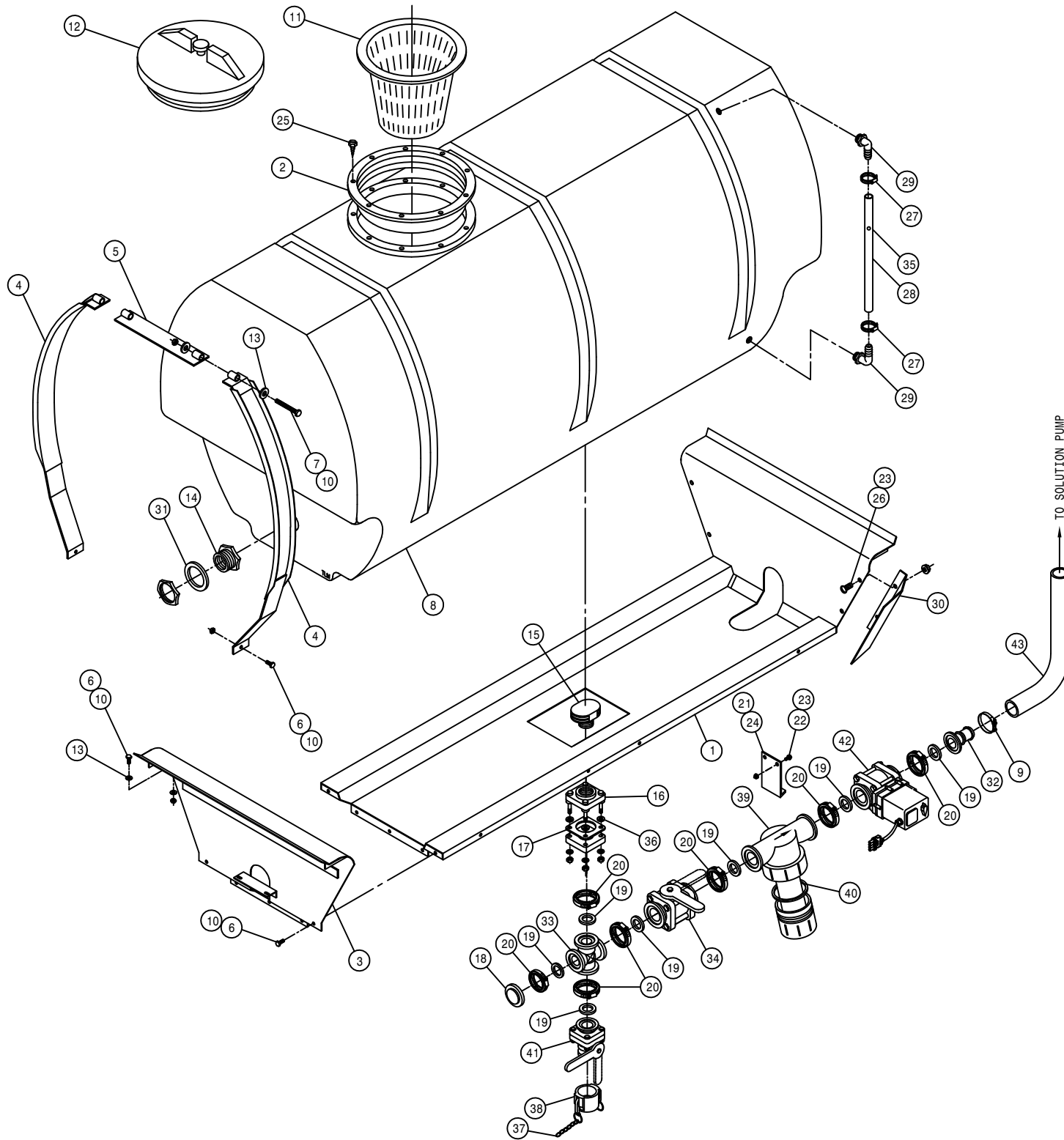

LH POLY 400 GALLON SOLUTION TANK ASSEMBLY

DET.	QTY	PART NO.	DESCRIPTION
1	1	763434	POLY TANK CRADLE WELD, 284 94
2	1	763409	10" THD'D RING FOR TANK LID
3	1	763340	REAR POLY CRADLE MT WLD280 90
4	6	763454	TANK BAND WLD, 284 POLY 95
5	3	763456	TANK BAND TIE WLD,284 POLY 95
6	15	900129	3/8UNC X 1" HEX BOLT
7	6	906138	3/8UNC X 3 1/2 HEX BOLT FULL
8	1	763440	400 GAL GRAY POLY SOLU TANK 94
9	1	520133	1.81/2.06 T-BOLT HOSE CLAMP SS
10	21	914004	3/8UNC HEX STOVER NUT
11	1	763431	8" STRAINER BASKET, SOLU TANK
12	1	763408	LID, THD'D W/VENT, POLY TANK
13	20	920002	3/8 SAE FLAT WASHER
14	2	618548	1.25 PLASTIC FTG ASSY POLYTANK
15	1	500077	VENT CAP, 2" W/O SCREEN,POLY
16	1	500179	2"FLG TANK FTG,BOTDRN BLT POLY
17	1	500087	GASKET,2" TANK FLG 500076/179
18	1	500156	2" FLANGE CAP PLUG POLY
19	7	500158	1 1/2" GASKET FOR 2" FLANGE
20	7	500160	2" FLANGE CLAMP, S.S.
21	1	470000	CABLE TIE, 21" BLACK PLASTIC
22	2	470118	1/4UNC X 3/4 FLANGE HEX BOLT
23	4	470121	1/4UNC HEX FLANGE LOCK NUT
24	1	763363	SOLU HOSE SUPPORT 280 POLY 91
25	8	763410	S.S. SCREW FOR CAP RING
26	2	472269	1/4UNC X 1/2 TRUSS HD BOLT
27	2	520069	HOSE CLAMP NO 6 STAINLESS
28	1	601245	HOSE, 1/2 X 42 CLEAR VINYL
29	2	618556	1/4NPT-90-1/2 HOSE BARB,POLY
30	1	763437	LH SIGHT GAGE SHLD,POLY284 94
31	2	763430	1 1/4 TANK FLANGE RUBBER SEAL
32	1	500162	2" FLANGE-1 1/2 HOSE BARB POLY
33	1	500176	2" FLANGE CROSS POLY
34	1	696142	BALL VLV, 2" FLANGE
35	1	763446	RED POLYPROPYLENE BALL 25/64"
36	4	500100	FOOT GASKET,2" FLG 500076/179
37	1	160986	CHAIN, 12.00 LONG
38	1	690623	CAP FOR 2.00 MALE COUPLER POLY
39	1	690628	LINE "Y" STRAINER, 2" FLANGE
40	1	690629	50 MESH SCREEN FOR 690628
41	1	696141	BALL VLV,2"FLANGE/2"MALE ADPTR
42	1	696176	ELECT BALL VLV,2"FLANGE BANJO
43	1	601329	HOSE, 1 1/2 X 130 2F-1W EPDM

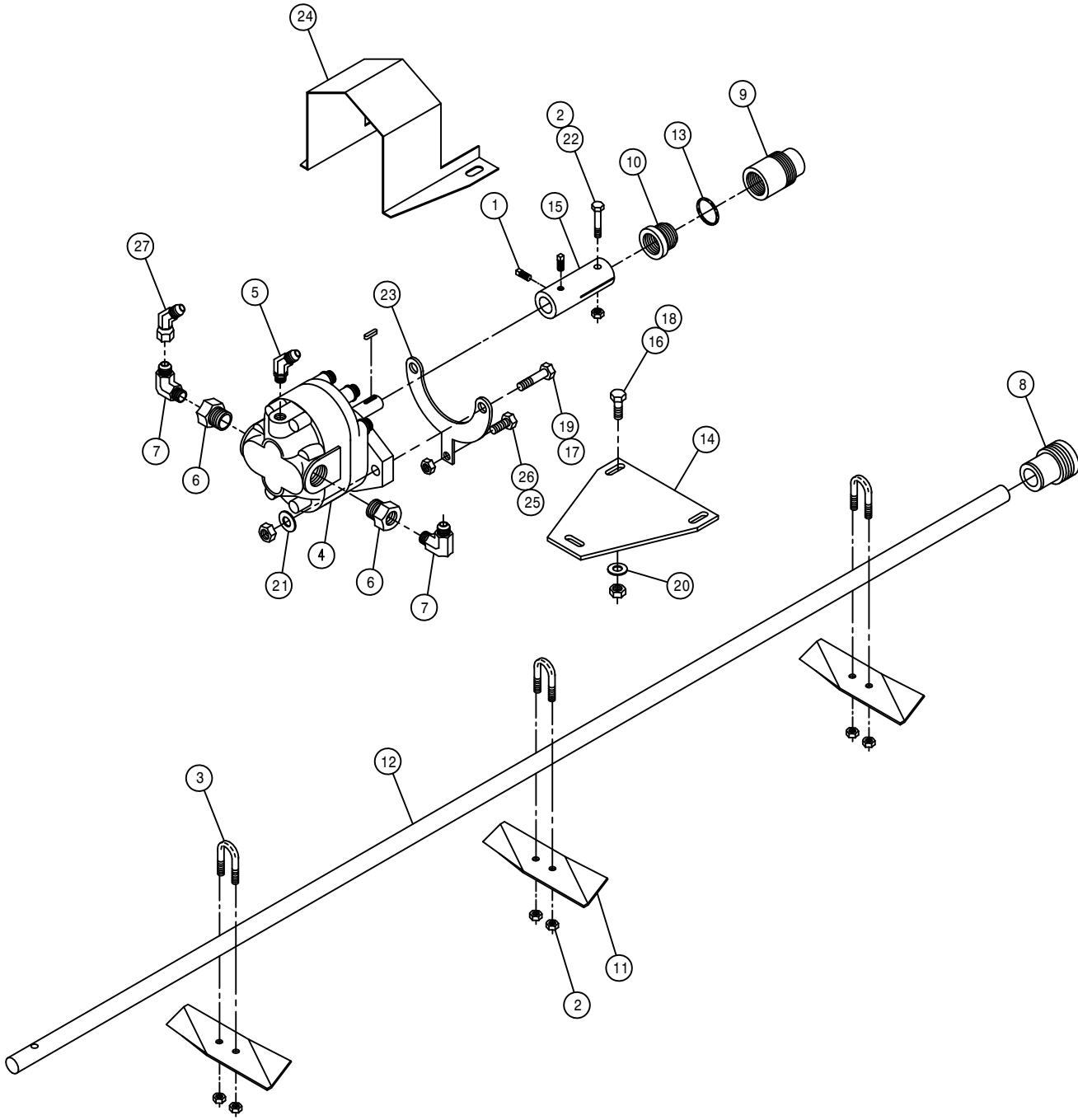

LH POLY TANK AGITATOR ASSEMBLY

DET.	QTY	PART NO.	DESCRIPTION	
1	2	470199	1/4UNC X 3/8 SQHD CUP SET SCR	
2	7	470089	1/4UNC HEX LOC NUT NYL INS SS	
3	3	470092	1/4UNC-3/4ID-1 1/4 U-BOLT SS	
4	1	610510	CESSNA GEAR MOTOR 1.48CI	
5	1	618338	9/16MJIC-45-1/4MNPT LBO	
6	2	618092	1 1/16MOR-1/2FNPT ADPTR	
7	2	618107	9/16MJIC-90-1/2MNPT LBO	
8	1	706403	FRT AGIT SHFT BRG, NYLON	
9	1	706401	REAR AGIT SHFT BRG, NYLON	
10	1	706402	AGIT SHFT GLAND NUT, NYLON	
11	3	763027	AGIT IMPELLER	
12	1	763360	AGIT SHAFT 280	91
13	1	763217	GLAND PACKING, 13 IN. LONG	
14	1	763357	AGIT MTR MT PLT CES 280	91
15	1	763359	AGIT MTR CPLR 280	91
16	2	900064	5/16UNC X 3/4 HEX BOLT	
17	2	900130	3/8UNC X 1 1/4 HEX BOLT	
18	2	914002	5/16UNC HEX STOVER NUT	
19	2	914004	3/8UNC HEX STOVER NUT	
20	2	920001	5/16 SAE FLAT WASHER	
21	2	920002	3/8 SAE FLAT WASHER	
22	1	470200	1/4UNC X 1 3/4 HEX BOLT SS	
23	1	763358	AGIT MTR MT YOKE CES 280	91
24	1	763361	AGIT CPLR SHIELD 280	91
25	1	900000	1/4UNC X 1/2 HEX BOLT	
26	1	914000	1/4UNC HEX STOVER NUT	
27	1	618634	9/16MJIC-45-9/16FJIC SWIV LBO	

HYPRO DBS140 PUMP ASSEMBLY

DET. QTY PART NO. DESCRIPTION

DET.	QTY	PART NO.	DESCRIPTION
1	1	220026	SPROCKET,40BS16,1.25ID,.312KEY
2	1	220027	SPROCKET WLD,4016-1.375-6SPL
3	1	492084	CHAIN FOR 4016 CHAIN COUPLER
4	1	500122	1 1/2" X 1"FNPT REDU CPLNGPOLY
5	3	500151	2" FLANGE TEE POLY
6	8	500158	1 1/2" GASKET FOR 2" FLANGE
7	8	500160	2" FLANGE CLAMP, S.S.
8	1	500165	2" FLANGE-1 1/2" MNPT POLY
9	1	500180	2"FLANGE-90-2"FLANGE LBO POLY
10	2	500162	2" FLANGE-1 1/2 HOSE BARB POLY
11	1	500189	2" FLANGE-90-1" HOSE BARB POLY
12	2	505114	SS PIPE ST EL 90DEG 1.00NPT
13	2	507023	SS CLOSE PIPE NIPPLE, 1.00MNPT
14	1	507730	1"-3/4"NPT REDU BUSH, SS
15	2	507731	3/8NPT PIPE PLUG, SQ HEAD, SS
16	1	507739	1" NPT PIPE TEE, SS
17	2	520090	HOSE CLAMP NO 16 STAINLESS
18	1	601600	HOSE, 1 X 6 2BR BLK EPDM
19	1	618171	7/8MOR-3/4FOR ADPTR
20	1	618183	3/4MJIC-90-7/8MOR LBO
21	1	618241	3/4MJIC-90-3/4MOR LBO
22	1	699702	HAMILTON RELIEF VLV 200PSI
23	1	505302	RED CPLG 1 1/4 TO 1, BLK
24	1	715664	1 1/4 NPT X 1 HOSE BARB
25	1	690364	D150-D230 PUMP CPLR SHLD
26	1	690885	HYPRO DBS140 PUMP
27	1	690886	PUMP MT PLT, HYPRO DBS140
28	1	690887	MTR MT WLD, HYPRO DBS140
29	1	690889	1"FNPT ADAPTER, HYPRO DBS140
30	1	695985	CHAR LYNN 2000 HYD MTR, 6.1CI
31	2	690893	SOLU PUMP MT PLATE SUPP,284TXP
32	1	714561	1.00NPT-1.25 HOSE BARB
33	1	520087	HOSE CLAMP NO 20 STAINLESS
34	2	900003	1/4UNC X 1" HEX BOLT
35	12	900129	3/8UNC X 1" HEX BOLT
36	4	900264	1/2UNC X 1 1/4 HEX BOLT
37	2	900265	1/2UNC X 1 1/2 HEX BOLT
38	2	914000	1/4UNC HEX STOVER NUT
39	12	914004	3/8UNC HEX STOVER NUT
40	6	914008	1/2UNC HEX STOVER NUT
41	8	920002	3/8 SAE FLAT WASHER
42	4	920004	1/2 SAE FLAT WASHER
43	1	500172	2" FLANGE-1" HOSE BARB POLY
44	1	520132	1.62/1.87 T-BOLT HOSE CLAMP SS
45	2	520133	1.81/2.06 T-BOLT HOSE CLAMP SS
46	1	601618	HOSE, 1 1/4 X 188 2BR BLK EPDM
47	1	690894	SHAFT GUARD WLD, 284TXP 04
48	2	473827	8MM-1.25 X 20MM HEX BOLT
49	2	473849	8MM FLAT WASHER

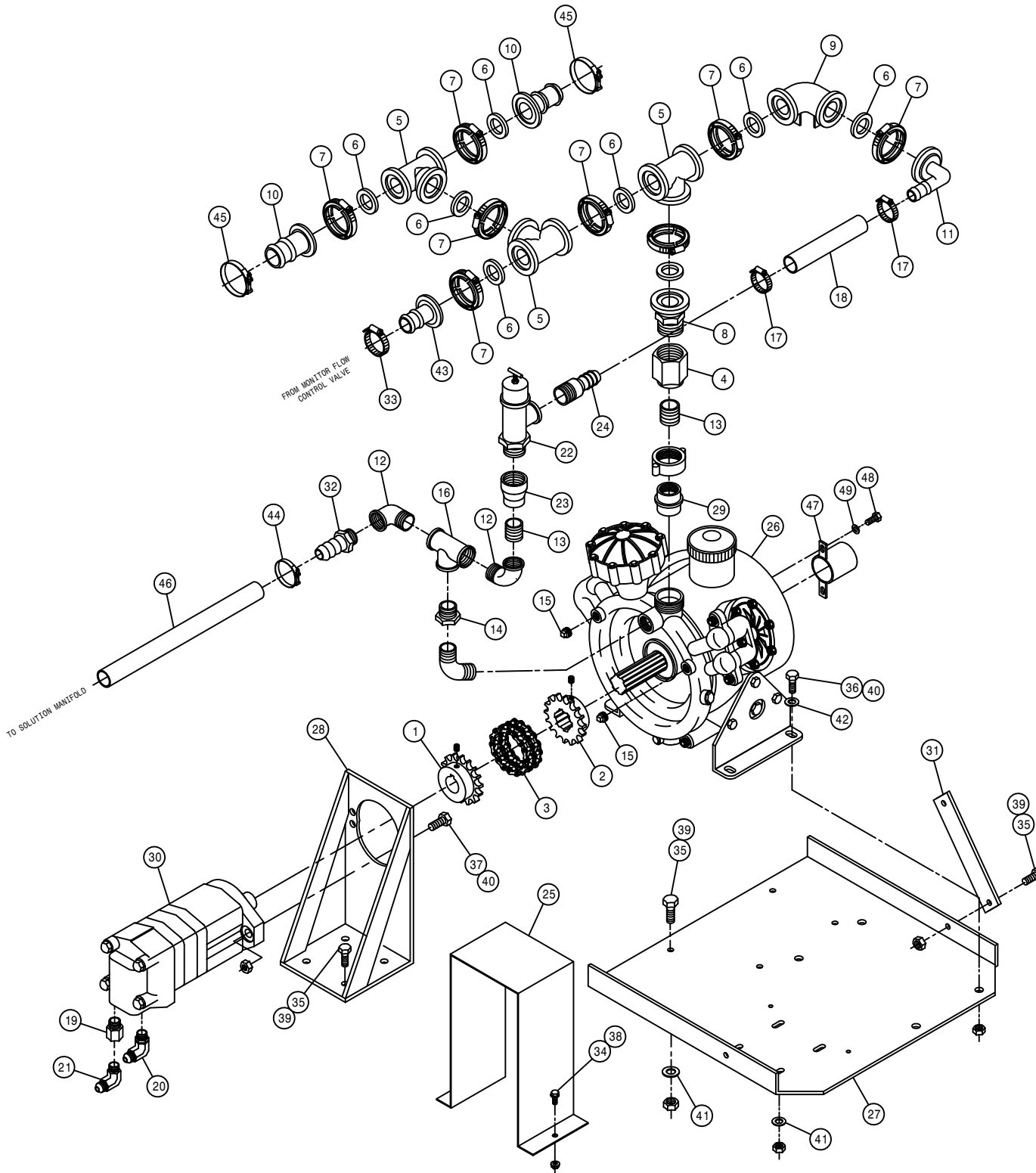

MONITOR FITTING ASSEMBLY

DET. QTY PART NO. DESCRIPTION

1	1	601602	HOSE, 1 X 68 2BR BLK EPDM
2	4	472349	1/4 X 3/4 20THD-IN TEK TYPE
3	1	505200	BLK PIPE ST EL 90DEG 1.00NPT
4	2	505201	CLOSE NIPPLE 1.00NPT
5	1	506005	1 1/4 TO 1 RED BUSH BLK MAL
6	1	506105	BLK PIPE TEE 1.25NPT
7	4	520132	1.62/1.87 T-BOLT HOSE CLAMP SS
8	2	520068	HOSE CLAMP NO 32 STAINLESS
9	1	690406	CONTROL VALVE, 1" POLY, RAVEN
10	1	696129	BALL VALVE, 1"FNPT 300PSI
11	1	500024	1"NPT-90-1"HOSE BARB, POLY
12	2	715660	HOSE BARB 1 1/4NPT X 1 1/4
13	1	520087	HOSE CLAMP NO 20 STAINLESS
14	1	690405	RFM 55 FLOW METER RAVEN
15	1	690481	CTRL VLV FTG SUPPORT WLD 94
16	1	601294	HOSE, 1 1/4 X 96 2BR BLK EPDM
17	1	601616	HOSE, 1 1/4 X 10 2BR BLK EPDM
18	1	601617	HOSE, 1 1/4 X 60 2BR BLK EPDM

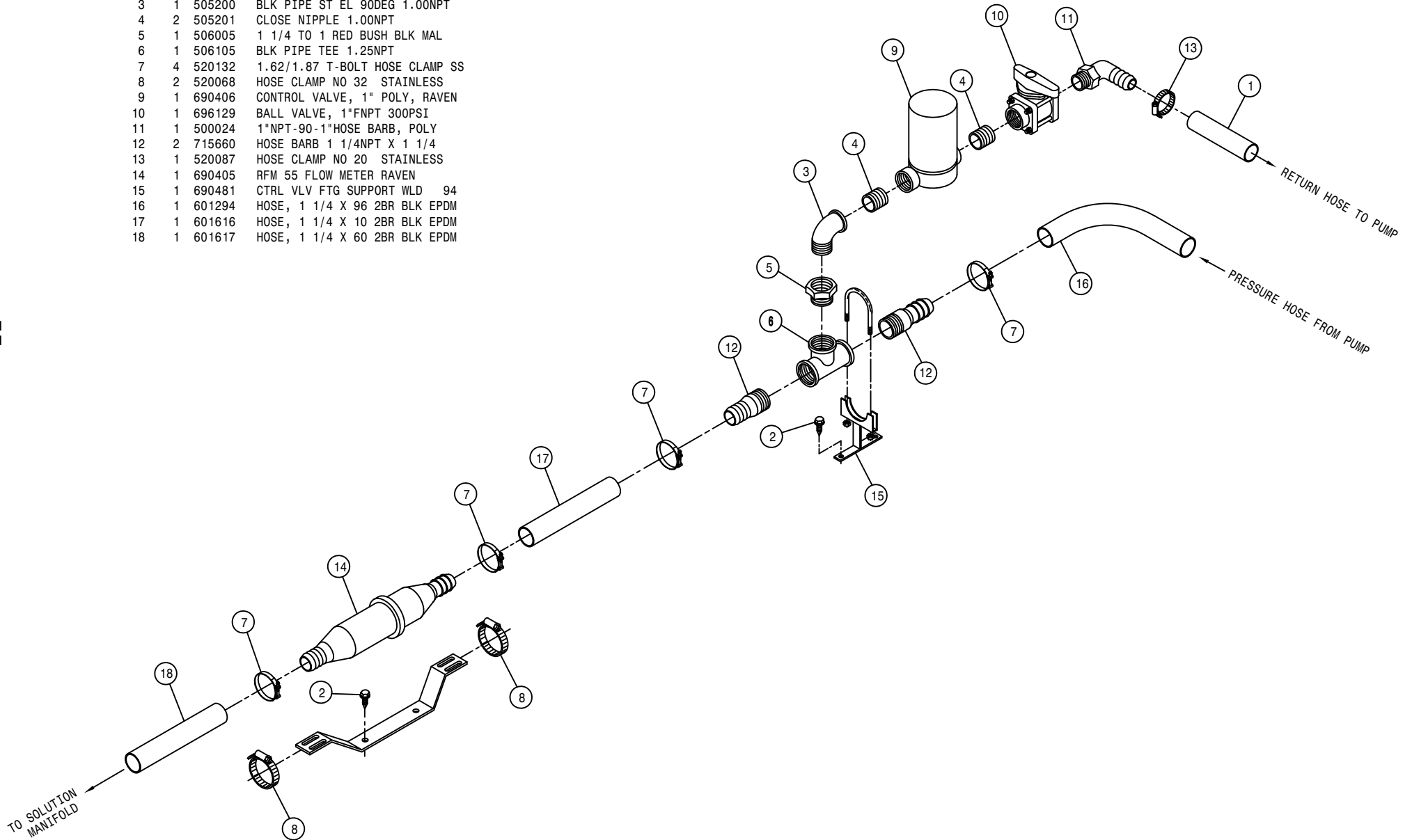

SOLUTION MANIFOLD ASSEMBLY

DET. QTY PART NO. DESCRIPTION

DET.	QTY	PART NO.	DESCRIPTION
1	1	503400	BLK PIPE ST EL 90DEG .50NPT
2	1	504210	RED BUSH 3/4 NPT X 1/2 NPT
3	3	716000	3/4 HOSE BARB-90-1MNPT
4	2	618281	1/2MNPT X 1/2 HOSE INSERT
5	3	696162	1" ELECT BALL VLV, 344AEC-2-1
6	1	695984	SOLU MANIF WLD D150-D230
7	2	695994	SOLU MANIF KEEPER OPTION
8	1	601340	HOSE, 3/4 X 276 2BR BLK EPDM
9	1	715660	HOSE BARB 1 1/4NPT X 1 1/4
10	1	507015	RED BUSH 1.50NPT - 1.25FNPT
11	1	504900	PIPE PLUG .75NPT SQ HD
12	4	900072	5/16UNC X 3" HEX BOLT
13	4	914002	5/16UNC HEX STOVER NUT
14	1	341520	PRESSURE GAUGE MT WLD 8240X11
15	1	501450	BLK PIPE ST EL 90DEG .25NPT
16	1	503000	RED BUSH 1/2 TO 1/4 BLK MAL
17	1	701350	PRESS GAUGE 300LB BOT FILL
18	4	520080	HOSE CLAMP NO 10 STAINLESS
19	6	520090	HOSE CLAMP NO 16 STAINLESS
20	1	520132	1.62/1.87 T-BOLT HOSE CLAMP SS
21	1	601615	HOSE, 1/2 X 175 2BR BLK EPDM
22	2	472349	1/4 X 3/4 20THD-IN TEK TYPE
23	1	601339	HOSE, 3/4 X 216 2BR BLK EPDM
24	1	601337	HOSE, 3/4 X 96 2BR BLK EPDM
25	1	506409	BLK PIPE ST EL 45DEG 1.25NPT

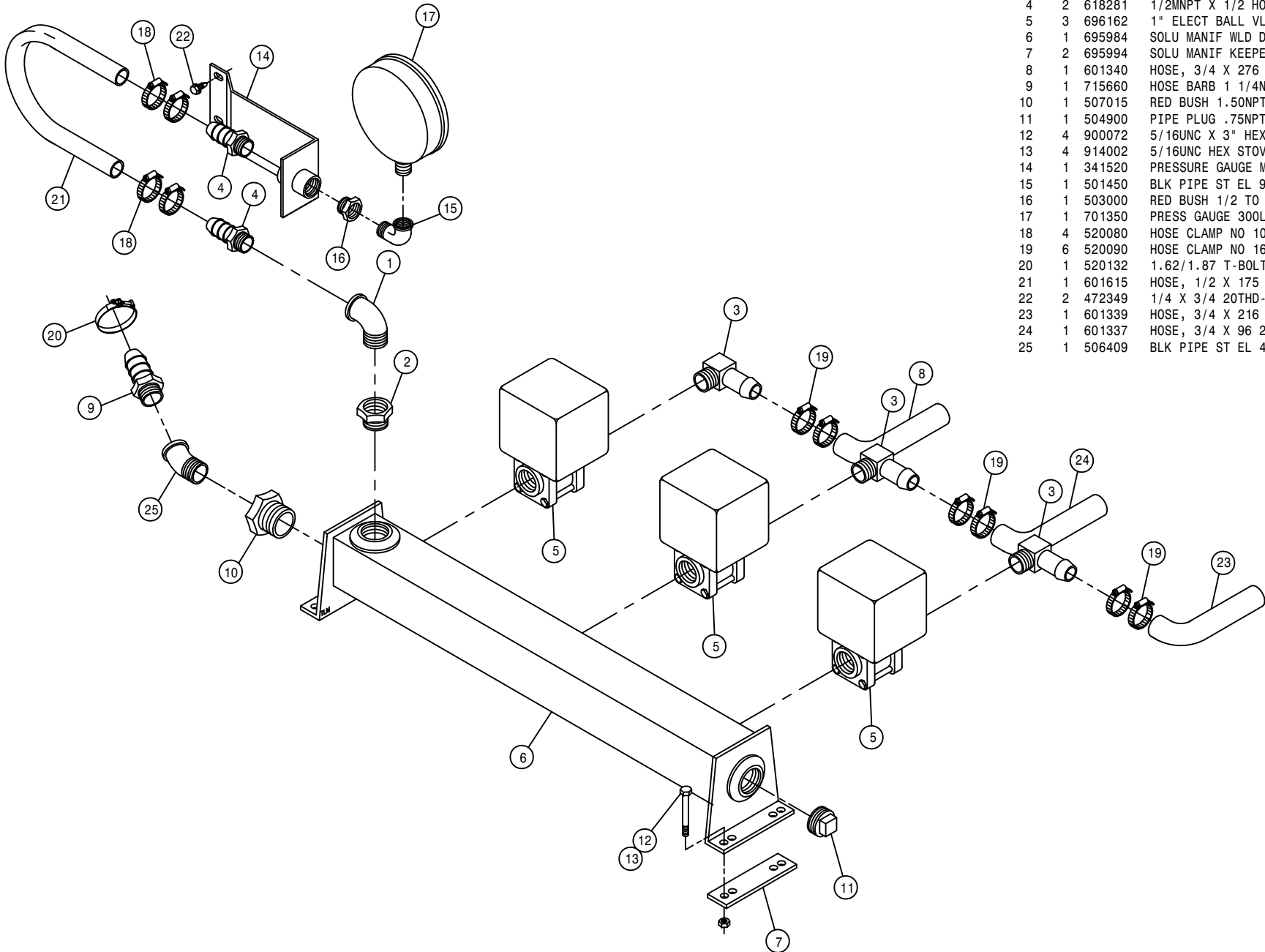



BOOM CONTROL VALVE ASSEMBLY

DET. QTY PART NO. DESCRIPTION

1	28	473802	# 8 INT TOOTH STAR WASHER
2	1	605615	HYD FILTER,INLINE 25M 9/16FOR
3	1	606102	BOOM VLV,X11/284/2100 PWRSYS03
4	1	618115	9/16MJIC-90-3/4MOR LBO
5	5	618119	9/16MJIC-90-9/16MOR LBO
6	5	618126	9/16MJIC-9/16MOR ADPTR
7	1	618241	3/4MJIC-90-3/4MOR LBO
8	1	618444	9/16MOR RUN TEE-9/16MJIC
9	2	618618	9/16MJIC-90-9/16FJIC SWIV LBO
10	1	618692	3/4FJIC SWIV-9/16MOR ADPTR
11	1	605616	ELEMENT,25M HYD FILTER 605615
12	1	605617	SPRING KIT, HYD FILTER 605615
13	2	900146	3/8UNC X 5 3/4 HEX BOLT
14	2	914004	3/8UNC HEX STOVER NUT
15	2	610185	9/16MOR PLUG
16	1	618486	9/16FJIC SW RUN TEE-9/16MJIC
17	2	614763	9/16MJIC-9/16MOR, .042 CHK ADPTR

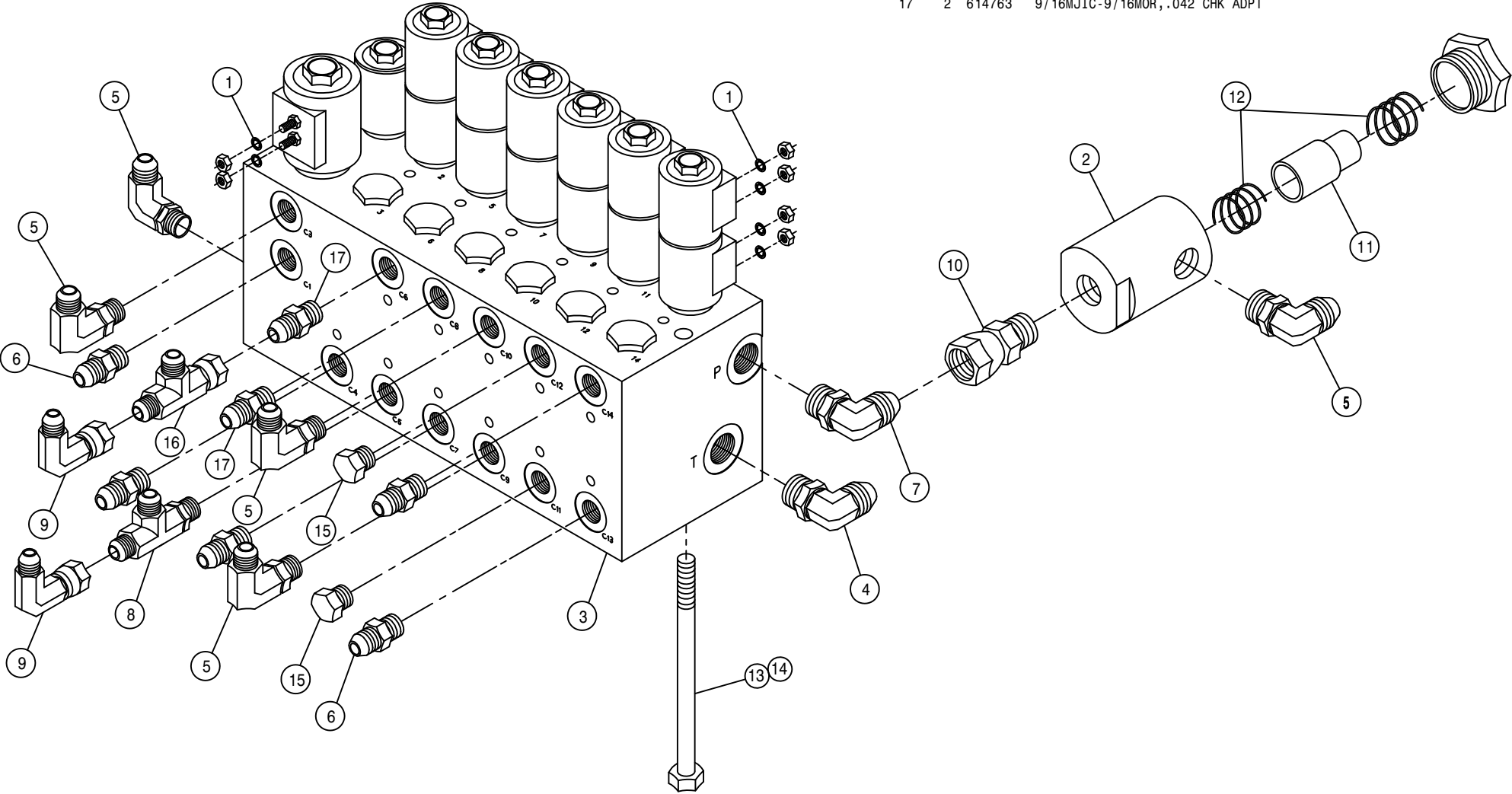

LIFTARM ASSEMBLY

DET. QTY PART NO. DESCRIPTION

DET.	QTY	PART NO.	DESCRIPTION
1	2	160471	LWR LIFT ARM WLD 8540-8250 87
2	1	164685	RH LIFT ARM MT WLD, 284XP 2001
3	1	164686	LH LIFT ARM MT WLD, 284XP 2001
4	12	160691	BUSH LIFT ARM LONG 470
5	9	470287	TUBE CLAMP, .375-.375 (PAIR)
6	1	164650	UPPER LIFT ARM WLD,254 X-11 01
7	12	471005	1/4 28 X 1/2 GREASE ZERK
8	3	900013	1/4UNC X 3 3/4 HEX BOLT
9	2	621207	TRANSOM LIFT CYL ASSY 284-2101
10	3	914000	1/4UNC HEX STOVER NUT
11	10	900334	5/8UNC X 1 3/4 HEX BOLT
12	4	900342	5/8UNC X 4" HEX BOLT
13	8	900343	5/8UNC X 4 1/2 HEX BOLT
14	30	914010	5/8UNC HEX STOVER NUT
15	1	615786	LIFT RAISE HYD TUBE ASSY X-11
16	1	615787	LIFT LOWER HYD TUBE ASSY X-11
17	1	615789	LEVEL LOWER HYD TUBE ASSY X-11
18	1	615788	LEVEL RAISE HYD TUBE ASSY X-11
19	2	618019	9/16MJIC UNION TEE
20	2	618618	9/16MJIC-90-9/16FJIC SWIV LBO
21	1	615791	RH FOLD LOWER HYD TUBE ASSYX11
22	1	615790	RH FOLD RAISE HYD TUBE ASSYX11
23	4	619010	9/16MJIC UNION
24	8	900338	5/8UNC X 3" HEX BOLT
25	2	164684	LIFT ARM MT KEEPER WLD 284XP

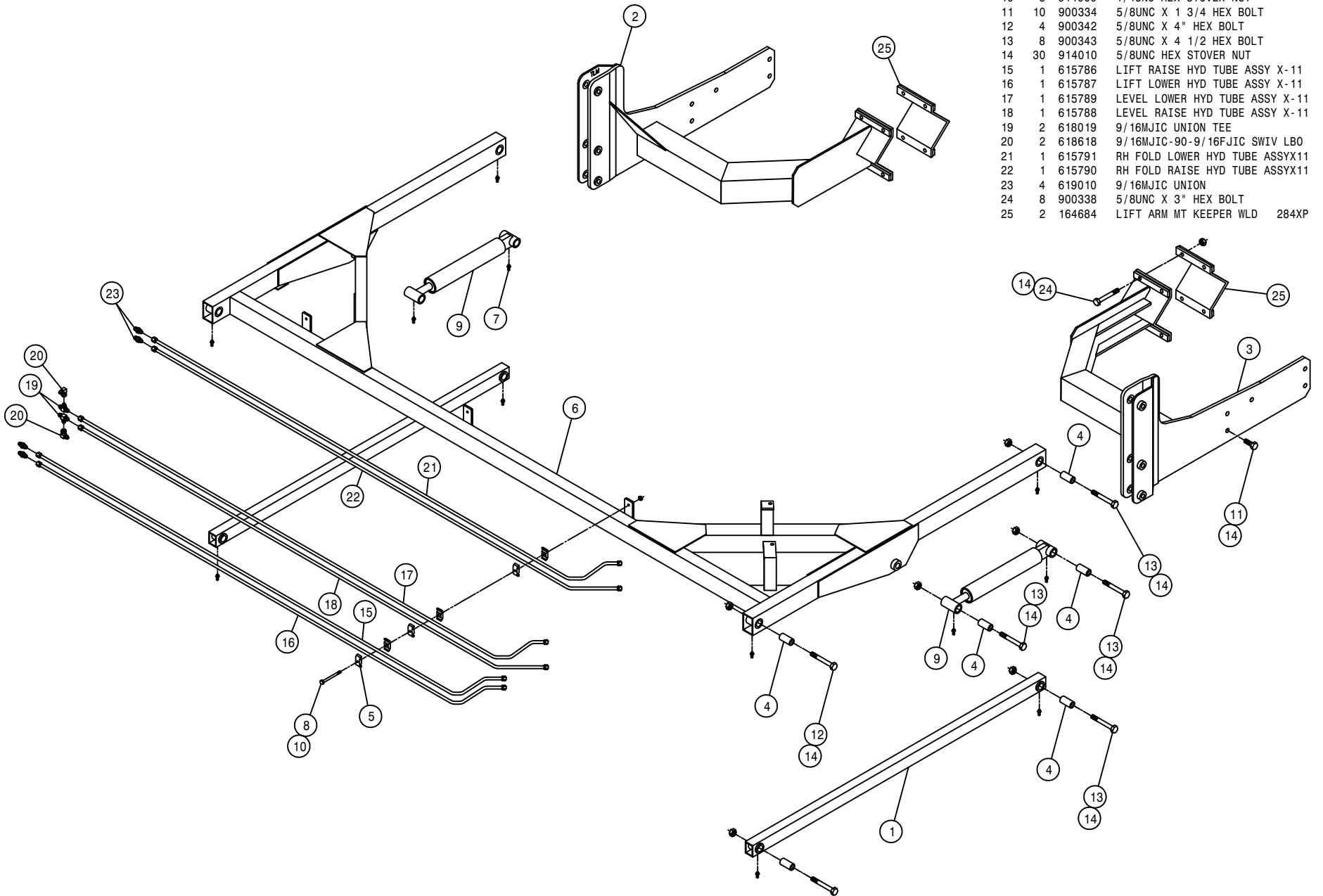

58

300058

TRANSOM ASSEMBLY

DET. QTY PART NO. DESCRIPTION

DET.	QTY	PART NO.	DESCRIPTION
1	2	160429	FEEDER HOSE SUPPORT SPRING MT
2	4	160691	BUSH LIFT ARM LONG 470
3	2	164124	NOZL MT TUBE,254X-11, 284W 96
4	4	164125	NOZL MT TUBE HANGER CHAN 96
5	4	164127	NOZL MT TUBE CLAMP 96
6	2	164128	LEVEL CYL PIVOT BRKT WLD 96
7	2	164315	BOOM BREAKAWAY WLD 97
8	4	629735	CAPLUG, 1 1/4" SQ, BLACK POLY
9	4	470136	3/8UNC-3 1/16ID-3 SQ U-BOLT
10	2	164264	5/8UNC X 3" EYE BOLT
11	6	471005	1/4 28 X 1/2 GREASE ZERK
12	16	900007	1/4UNC X 2" HEX BOLT
13	2	900849	5/8UNC X 4 1/2 HHCS,7/8THD GR8
14	2	910010	5/8UNC HEX NUT
15	16	914000	1/4UNC HEX STOVER NUT
16	8	914004	3/8UNC HEX STOVER NUT
17	2	470118	1/4UNC X 3/4 FLANGE HEX BOLT
18	12	914010	5/8UNC HEX STOVER NUT
19	8	920005	5/8 SAE FLAT WASHER
20	2	900848	5/8UNC X 4 3/4 HEX BOLT GR8
21	2	164230	BOOM PIVOT PIN, .75 X 13.31 96
22	4	470162	COTTER PIN 3/16 X 1 1/2 SQCUT
23	2	482000	SPRING, .930D X 8.5LG, .072WIRE
24	2	520126	CUSH HOSE CLAMP 2IN X 5/8W
25	2	621210	BOOM LEVEL CYL ASSY 04
26	2	621208	BOOM HINGE FOLD CYL ASSY 04
27	4	900829	5/8UNC X 4" HEX BOLT GR8
28	2	470121	1/4UNC HEX FLANGE LOCK NUT
29	2	900844	5/8UNC X 2 3/4 HEX BOLT GR8
30	4	920006	3/4 SAE FLAT WASHER
31	1	164743	TRANSOM WLD, 284TXP 03
32	2	471023	GREASE ZERK 1/4-28 X 45
33	2	621211	ACCUMULATOR CYL ASSY,60 BOOM
34	4	520099	HOSE CLAMP NO 40 STAINLESS

59

300059

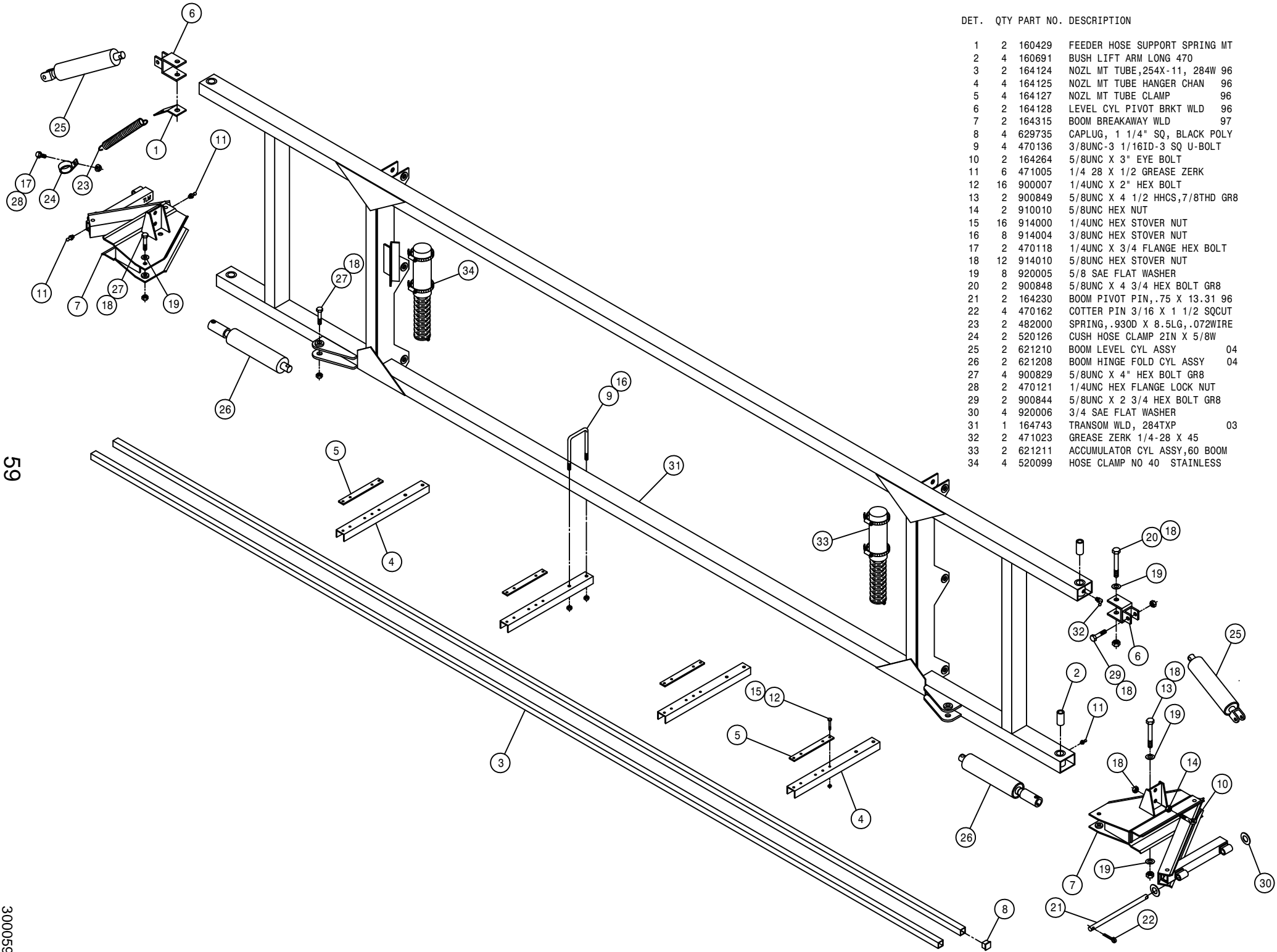

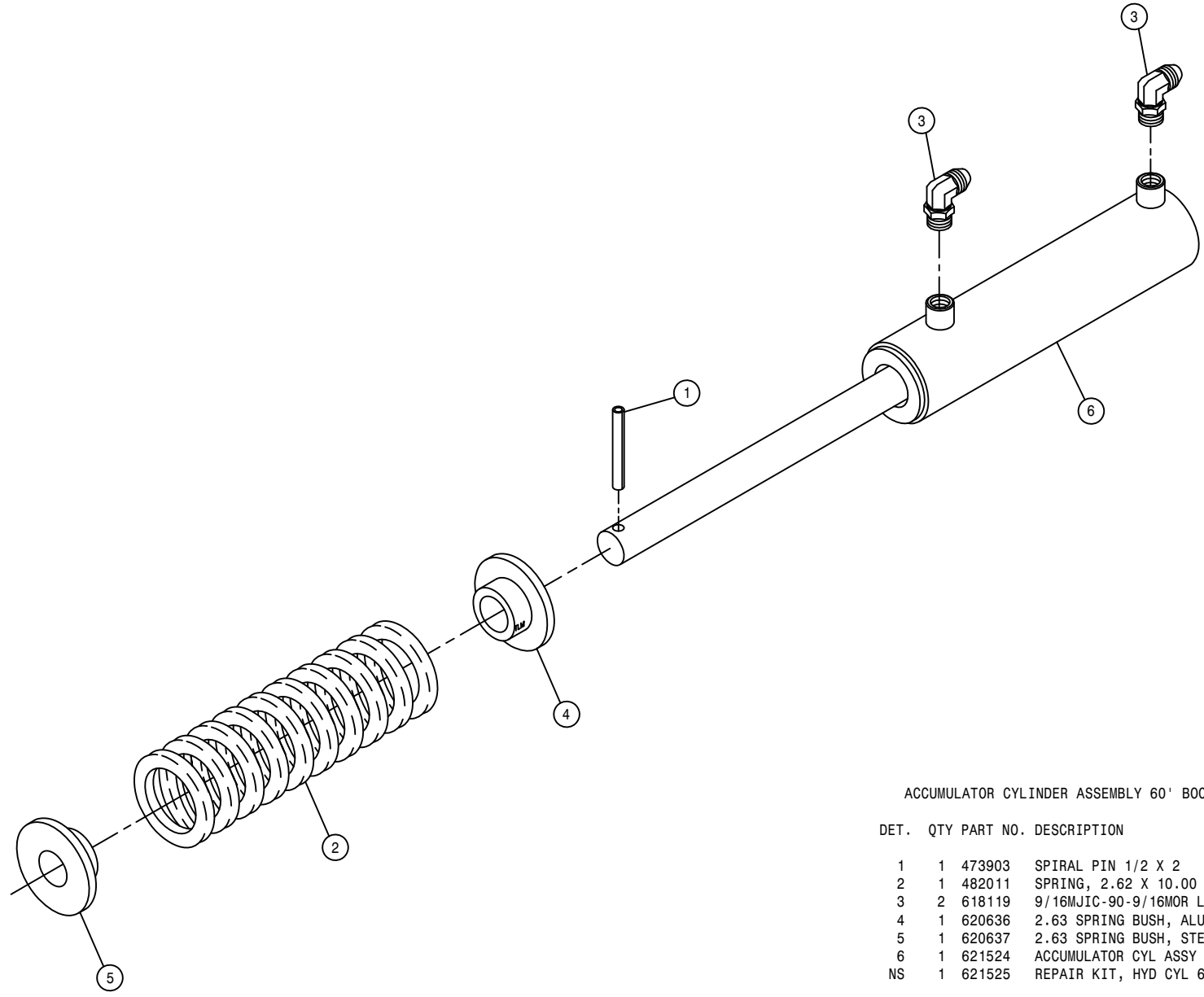

ACCUMULATOR CYLINDER ASSEMBLY 60' BOOM

DET.	QTY	PART NO.	DESCRIPTION	
	1	473903	SPIRAL PIN 1/2 X 2	640
	1	482011	SPRING, 2.62 X 10.00 COMPRSN	
	2	618119	9/16MJC-90-9/16MOR LBO	
	4	620636	2.63 SPRING BUSH, ALUM	96
	5	620637	2.63 SPRING BUSH, STEEL	96
	6	621524	ACCUMULATOR CYL ASSY	
NS	1	621525	REPAIR KIT, HYD CYL 621524	

NOTE: 621211 - ACCUMULATOR CYLINDER ASSEMBLY

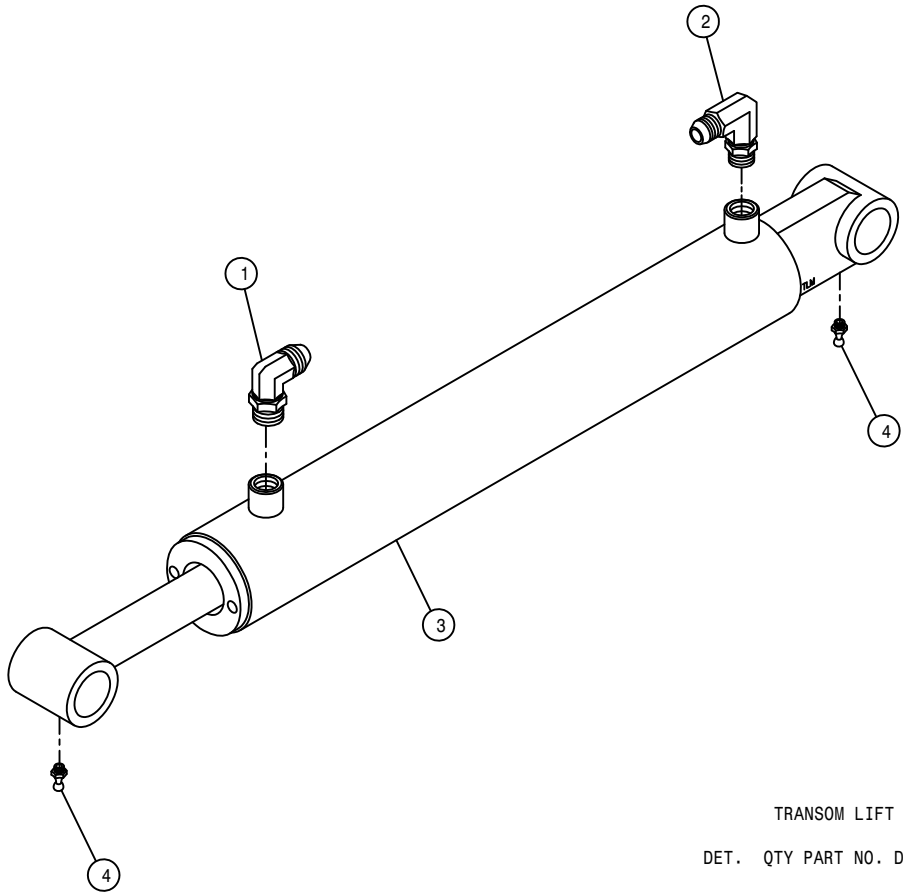

TRANSOM LIFT CYLINDER ASSEMBLY

DET.	QTY	PART NO.	DESCRIPTION
	1	618119	9/16MOR-90-9/16MOR LBO
	1	618689	9/16MOR-90-9/16MJ .042 CHK VLV
	1	621518	TRANSOM LIFT CYL ASSY
	4	471005	1/4 28 X 1/2 GREASE ZERK
	NS	621519	REPAIR KIT, HYD CYL 621518

NOTE: 621207 - TRANSOM LIFT CYLINDER ASSEMBLY WITH FITTINGS

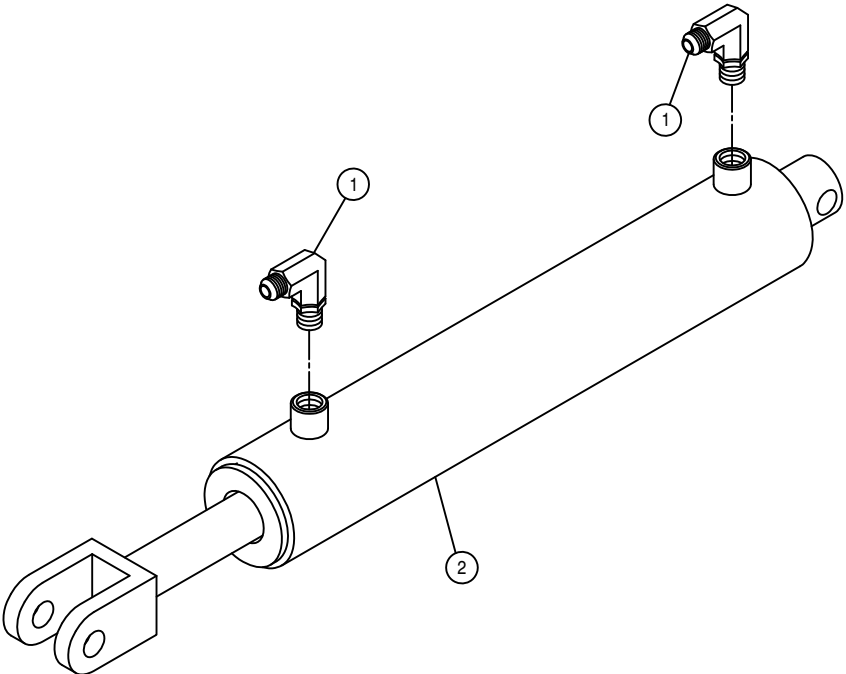

BOOM LEVEL CYLINDER ASSEMBLY

DET. QTY PART NO. DESCRIPTION

1	2	618119	9/16MJIC-90-9/16MOR LBO
2	1	621522	BOOM LEVEL CYL ASSY
NS	1	621523	REPAIR KIT, HYD CYL 621522

NOTE: 621210 - BOOM LEVEL CYLINDER ASSEMBLY WITH FITTINGS

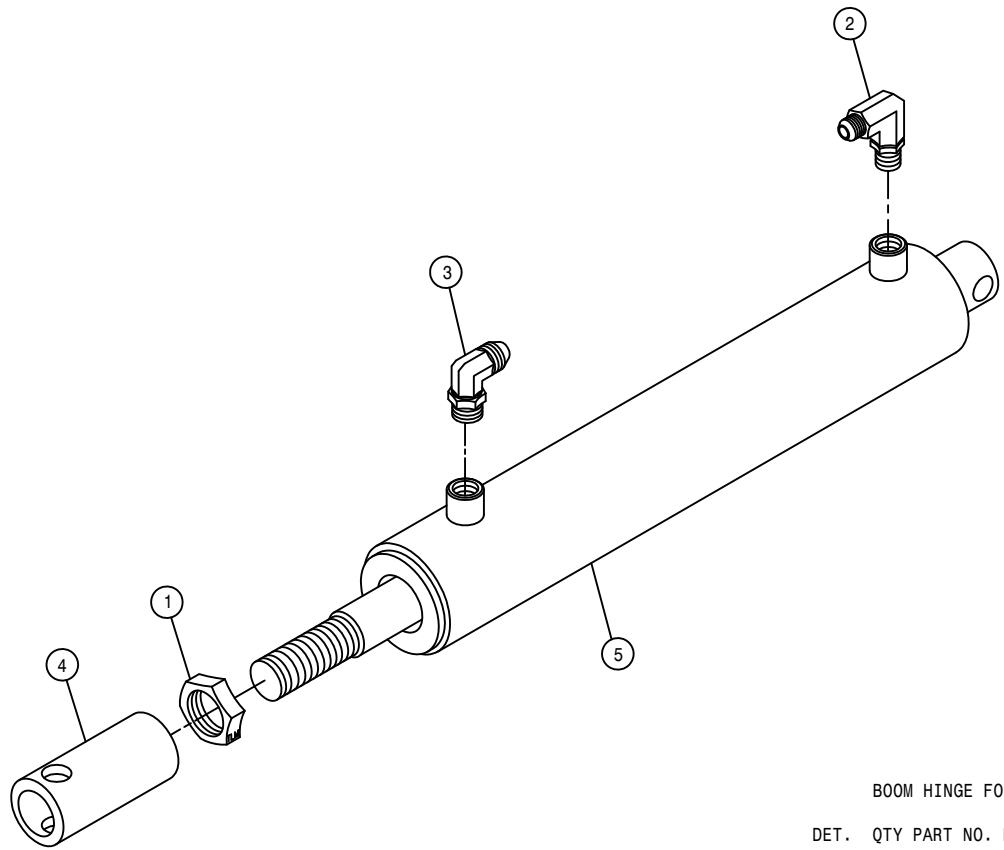

BOOM HINGE FOLD CYLINDER ASSEMBLY

DET. QTY PART NO. DESCRIPTION

1	1	472322	7/8-14 UNF HEX JAM NUT
2	1	614750	.042 ELBOW ASSY,9/16MOR 90D
3	1	618688	9/16MOR-90-9/16MJ .025 CHK VLV
4	1	620653	FOLD CYL ADJ SLEEVE 97
5	1	621520	BOOM HINGE FOLD CYL ASSY
NS	1	621521	REPAIR KIT, HYD CYL 621520

NOTE: 621208 - BOOM HINGE FOLD CYLINDER ASSEMBLY WITH FITTINGS

INNER BOOM ASSEMBLY

DET. QTY PART NO. DESCRIPTION

1	1	164150	BOOM WLD, INNER SECTION	96
2	1	164227	BOOM BALL JOINT BUSH	96
3	2	164263	SWIVEL, 5/8 BOOM EYEBOLT	
4	2	164265	5/8UNC X 7 1/2 EYE BOLT	
5	2	482014	SPRING, 3.25 X 11.50 EXTENSION	
6	4	910010	5/8UNC HEX NUT	
7	1	471028	GREASE ZERK, 1/4-28 90DEG	
8	1	900844	5/8UNC X 2 3/4 HEX BOLT GR8	
9	1	914010	5/8UNC HEX STOVER NUT	
10	2	164275	NOZL MT WLD	96
11	2	900007	1/4UNC X 2" HEX BOLT	
12	2	914000	1/4UNC HEX STOVER NUT	

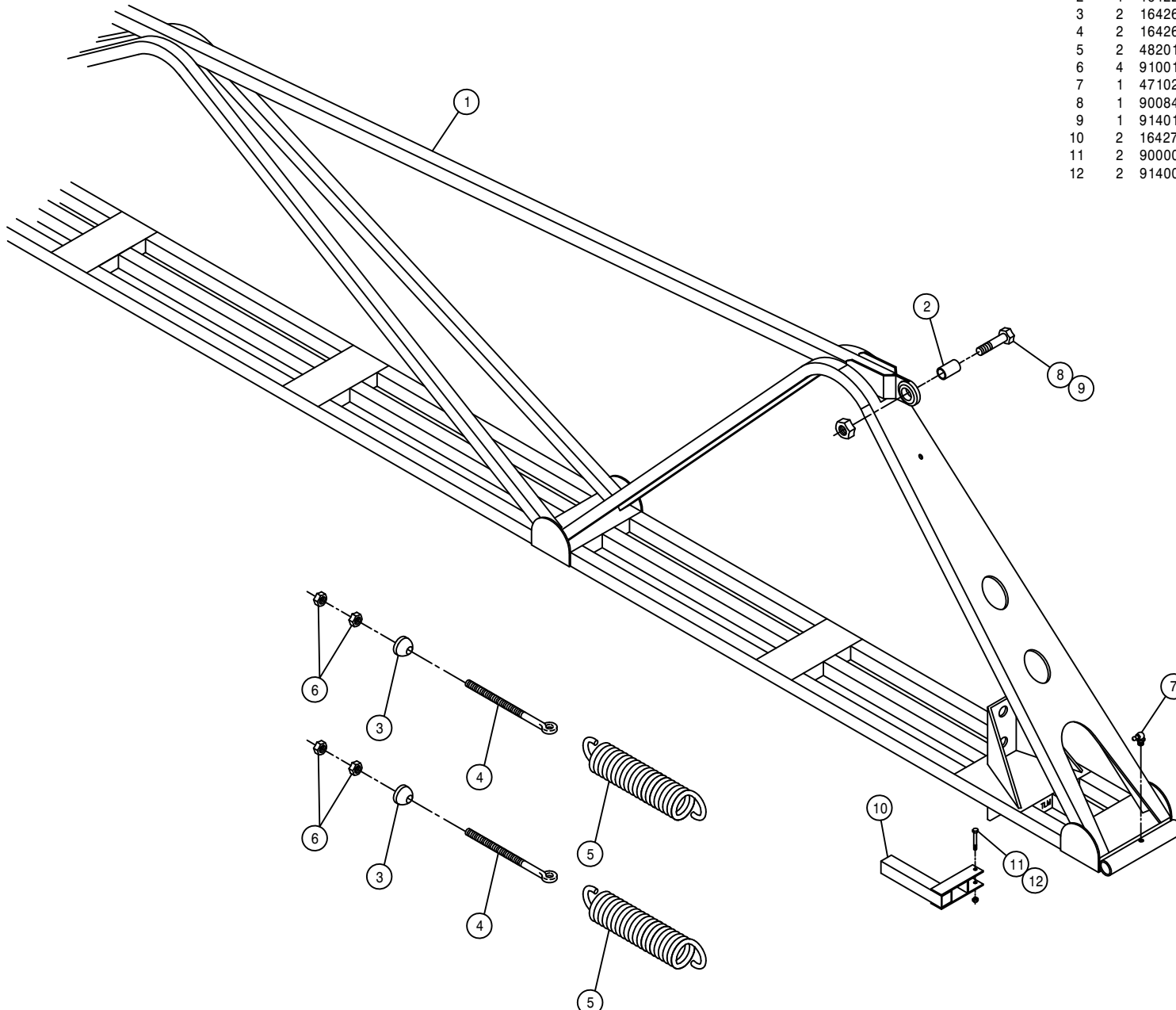



60' BOOM HINGE PIVOT ASSEMBLY

DET. QTY PART NO. DESCRIPTION

1	1	164205	BOOM WLD, 60' OUTER SECT	96
2	1	164231	BOOM PIN, 1.00 X 11.75	96
3	2	470162	COTTER PIN 3/16 X 1 1/2 SQ CUT	
4	1	472276	CLEVIS PIN, 1.00 X 2.00	PLT
5	1	611016	HAIR PIN #6	
6	2	900128	3/8UNC X 3/4 HEX BOLT	
7	2	914004	3/8UNC HEX STOVER NUT	
8	2	438302	HOSE SUPPORT RING WLD	
9	1	471028	GREASE ZERK, 1/4-28 90DEG	

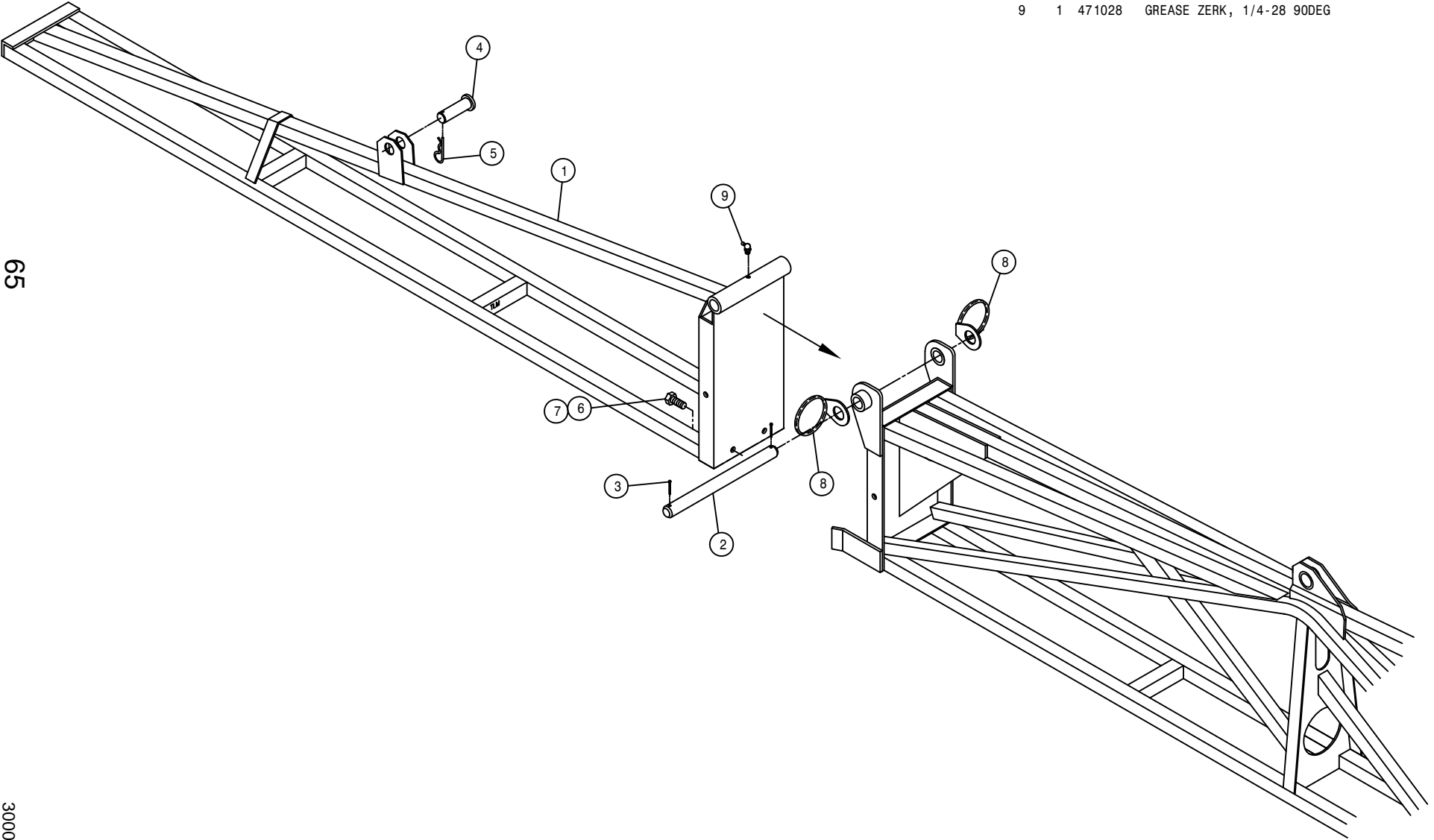

65

300065

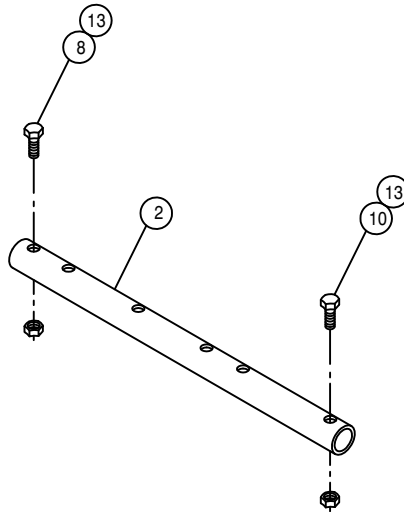
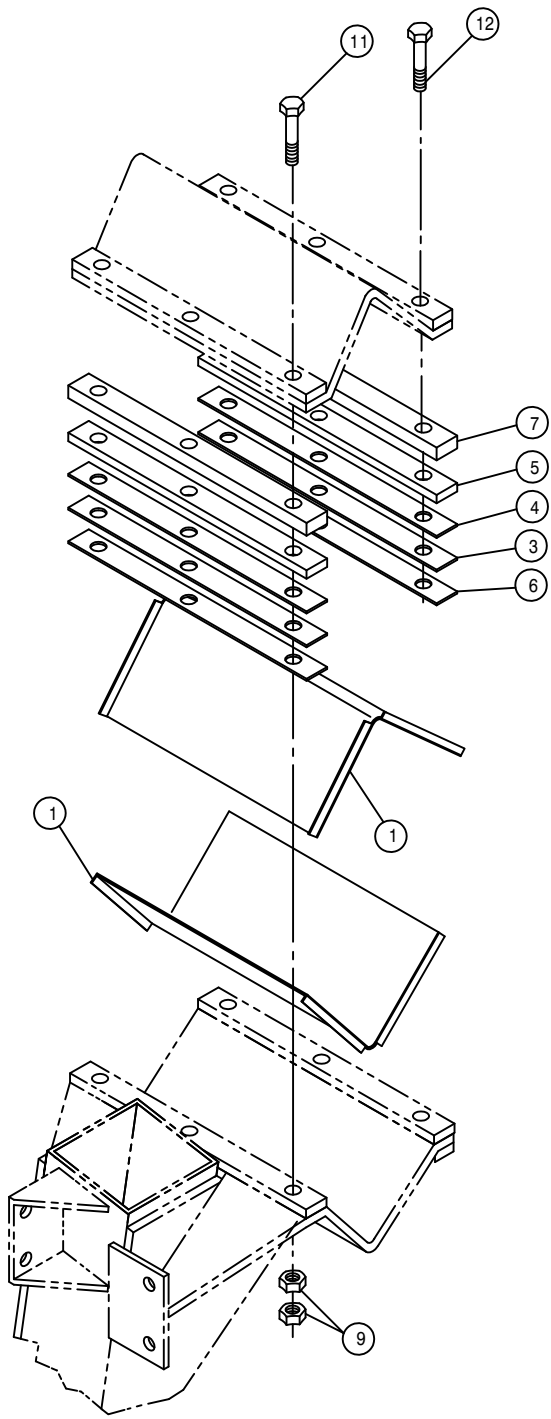

TREAD ADJUSTMENT ASSEMBLY

DET. QTY PART NO. DESCRIPTION

1	8	358703	TREAD ADJ XMBR BEARING ASSY	
2	4	358944	TREAD ADJ CYL EXT, 154" 2100 98	
3	8	358767	.025 LEG MT SHIM, 284T	94
4	8	358752	.074 LEG MT SHIM, 284T	94
5	8	358769	.250 LEG MT SHIM, 284T	94
6	8	358768	.037 LEG MT SHIM, 284T	94
7	8	358766	.375 LEG MT SPACER, 284T	94
8	4	900268	1/2UNC X 2 1/2 HEX BOLT	
9	48	914811	5/8UNF HEX NUT GR8	
10	4	900267	1/2UNC X 2" HEX BOLT	
11	12	900837	5/8UNF X 3 1/2 HEX BOLT GR8	
12	12	900838	5/8UNF X 4" HEX BOLT GR8	
13	8	914008	1/2UNC HEX STOVER NUT	

NOTE: QUANTITY LISTED IS FOR ONE MACHINE.

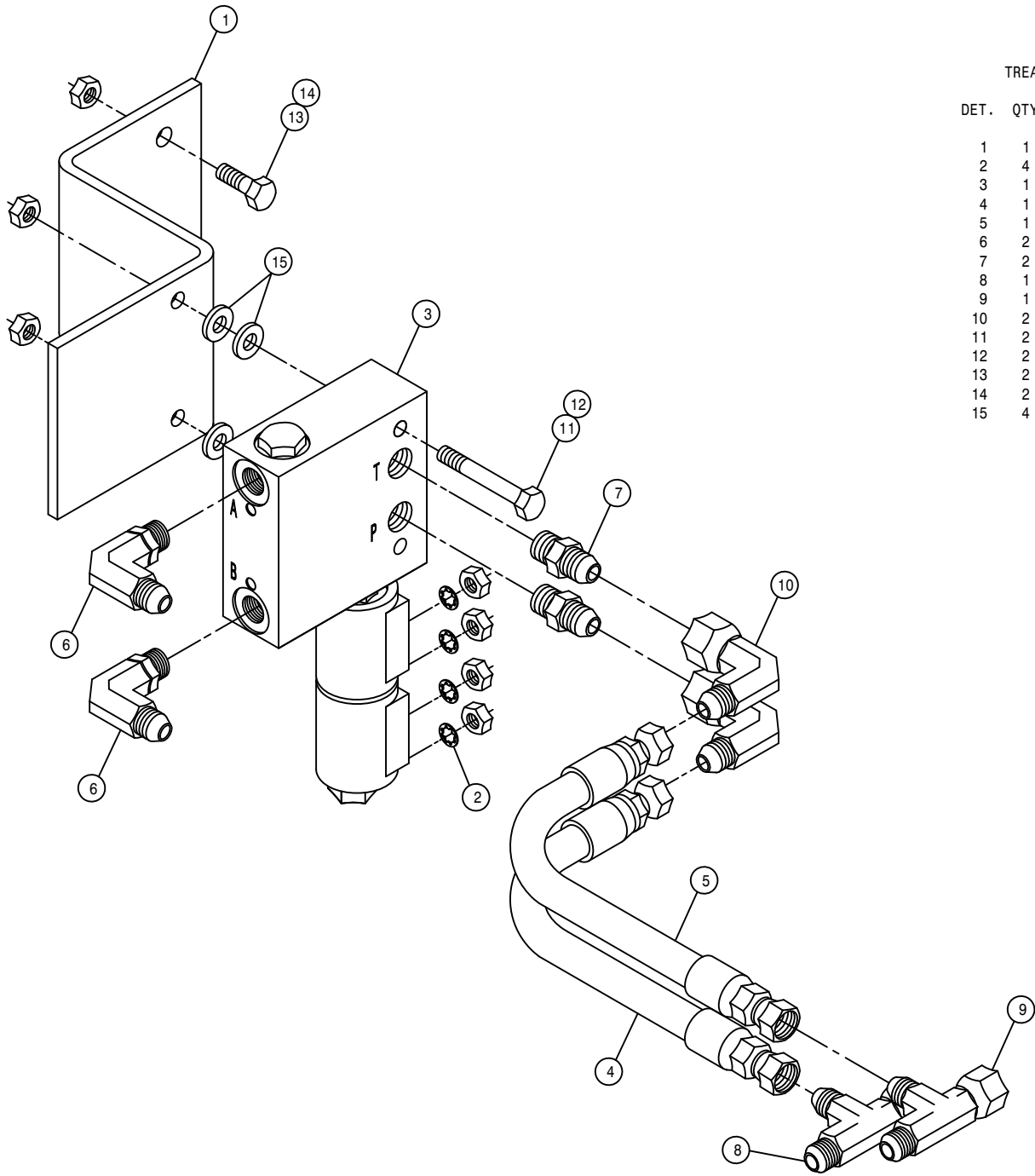

TREAD ADJUST CONTROL VALVE ASSEMBLY

DET.	QTY	PART NO.	DESCRIPTION
1	1	164652	TREAD ADJ VLV MT, 284
2	4	473802	# 8 INT TOOTH STAR WASHER
3	1	606100	TREAD ADJ VLV,284/XP,PWRSYS 03
4	1	615473	06C1T-06FJX-08FJX-18 H/A
5	1	615620	06C1T-06FJX-06FJX-18 H/A
6	2	618119	9/16MJIC-90-9/16MOR LBO
7	2	618126	9/16MJIC-9/16MOR ADPTR
8	1	618451	3/4FJIC SW RUN TEE-3/4MJIC
9	1	618486	9/16FJIC SW RUN TEE-9/16MJIC
10	2	618618	9/16MJIC-90-9/16FJIC SWIV LBO
11	2	900086	5/16UNC X 2 1/4 HEX BOLT
12	2	914002	5/16UNC HEX STOVER NUT
13	2	900129	3/8UNC X 1" HEX BOLT
14	2	914004	3/8UNC HEX STOVER NUT
15	4	920001	5/16 SAE FLAT WASHER

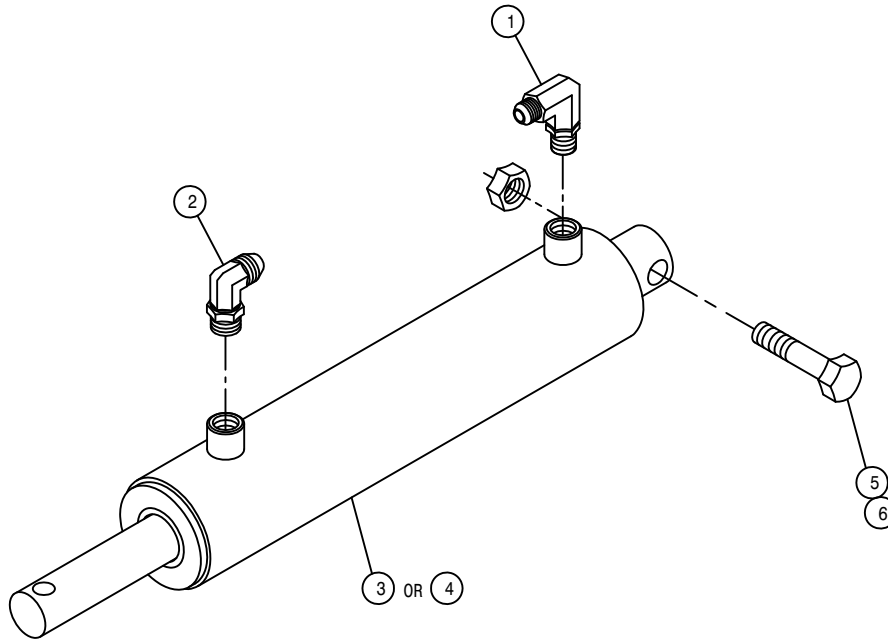

TREAD ADJUSTMENT LEG CYLINDER ASSEMBLY

DET.	QTY	PART NO.	DESCRIPTION
	1	614747	.025 ELBOW ASSY,9/16MOR 90D
	1	618119	9/16MJIC-90-9/16MOR LBO
	1	621534	LH TRD ADJ CYL,DTS8T-DTS10 04
	1	621536	RH TRD ADJ CYL,DTS8T-DTS10 04
	1	900268	1/2UNC X 2 1/2 HEX BOLT
	1	914008	1/2UNC HEX STOVER NUT
	1	621535	REPAIR KIT, HYD CYL 621534
	1	621537	REPAIR KIT, HYD CYL 621536

NOTE: 1. 621216 - LH LEG TREAD ADJ CYLINDER ASSEMBLY WITH FITTINGS  
 2. 621217 - RH LEG TREAD ADJ CYLINDER ASSEMBLY WITH FITTINGS

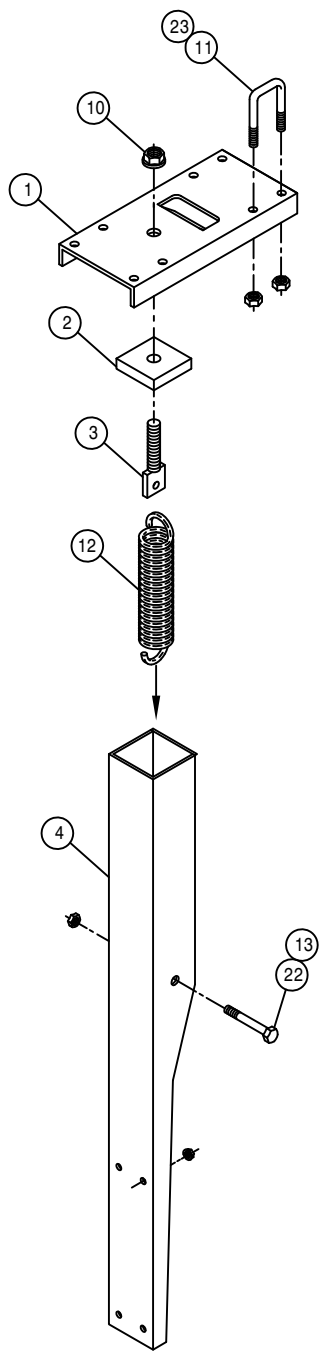
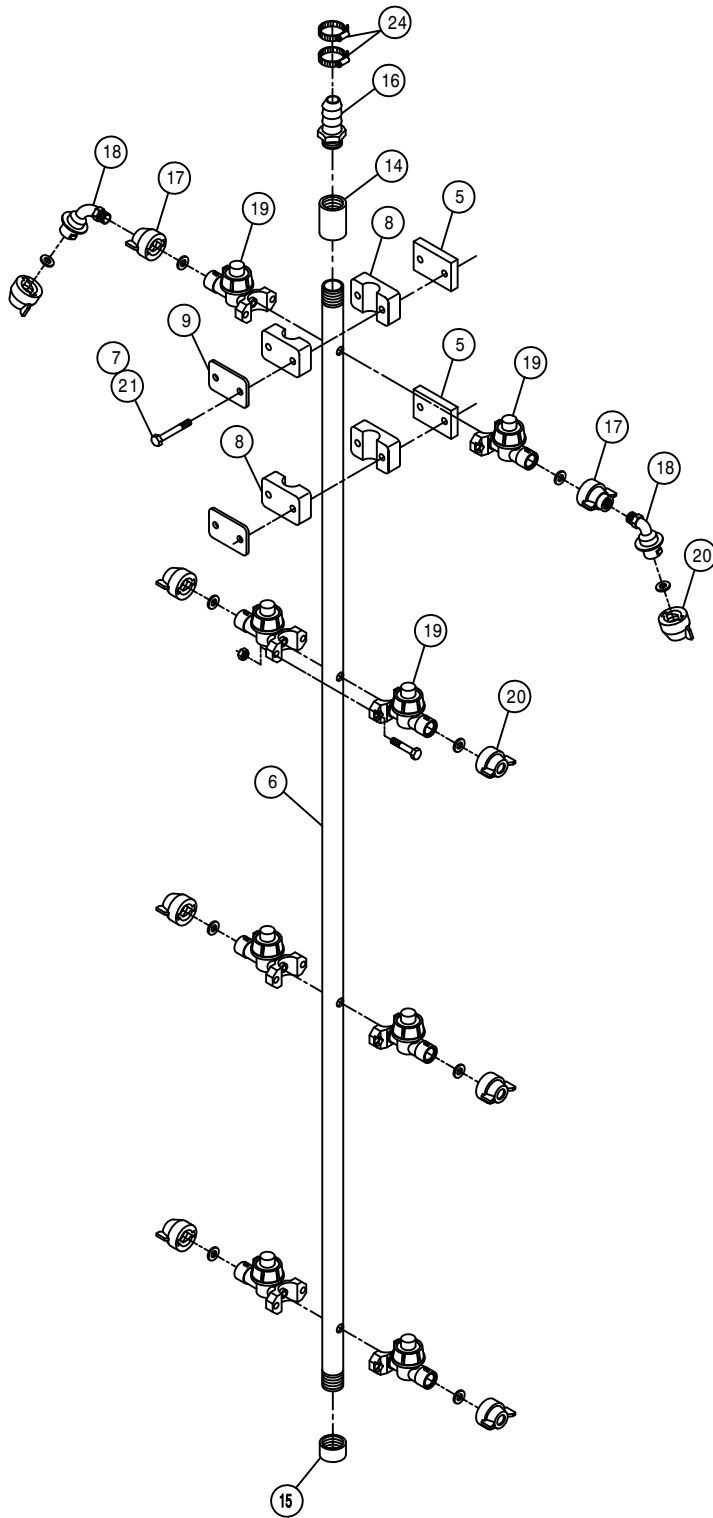

6' DROP NOZZLE ASSEMBLY

DET.	QTY	PART NO.	DESCRIPTION
	1	164761	6'DROP MT BASE CHAN, 284TXP 03
	2	164762	6'DROP PIVOT PAD WLD,284TXP 03
	3	164764	6'DROP SPRING BOLT WLD, TXP 03
	4	164766	6'DROP PIVOT CHAN WLD,284TXP03
	5	164769	DROP TUBE CLAMP SPACER, 284TXP
	6	164770	6'DROP WET TUBE 284TXP 03
	7	470121	1/4UNC HEX FLANGE LOCK NUT
	8	470358	TUBE CLAMP BODY, .840 (1/2PIPE)
	9	470359	COVER PLATE FOR 470358
	10	470360	1/2UNC HEX FLANGE LOCK NUT
	11	473973	.31UNC-1.31ID-2.0 SQ U-BOLT SS
	12	482022	SPRING,1.718 X 8.00 EXTENSION
	13	914004	3/8UNC HEX STOVER NUT
	14	507734	SS PIPE COUPLING .50NPT
	15	507735	1/2FNPT PIPE CAP, SS
	16	618281	1/2MNPT X 1/2 HOSE INSERT
	17	737835	QUICK TEEJET-1/4"FNPT ADPTR
	18	737842	1/4MNPT-45-QUICK TEEJET ADPTR
	19	737919	NOZL BODY, WET BOOM, 1/2" PIPE
	20	737920	CAP SET, BLACK, QUICK TEEJET
	21	900023	1/4UNC X 2 1/4 HEX BOLT
	22	900136	3/8UNC X 3" HEX BOLT
	23	914002	5/16UNC HEX STOVER NUT
	24	520055	HOSE CLAMP NO 12 STAINLESS

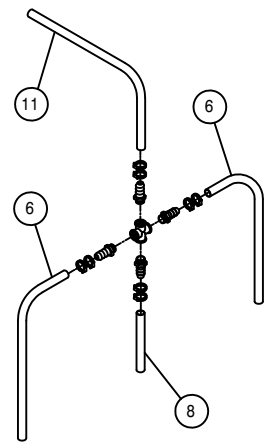
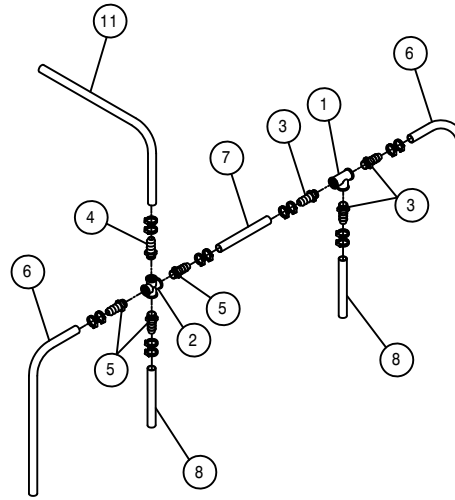
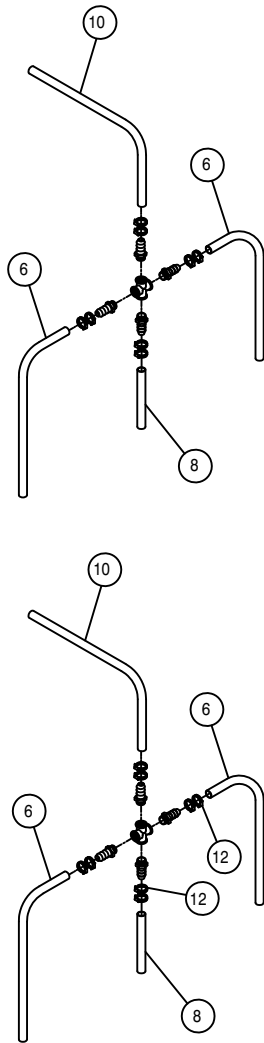
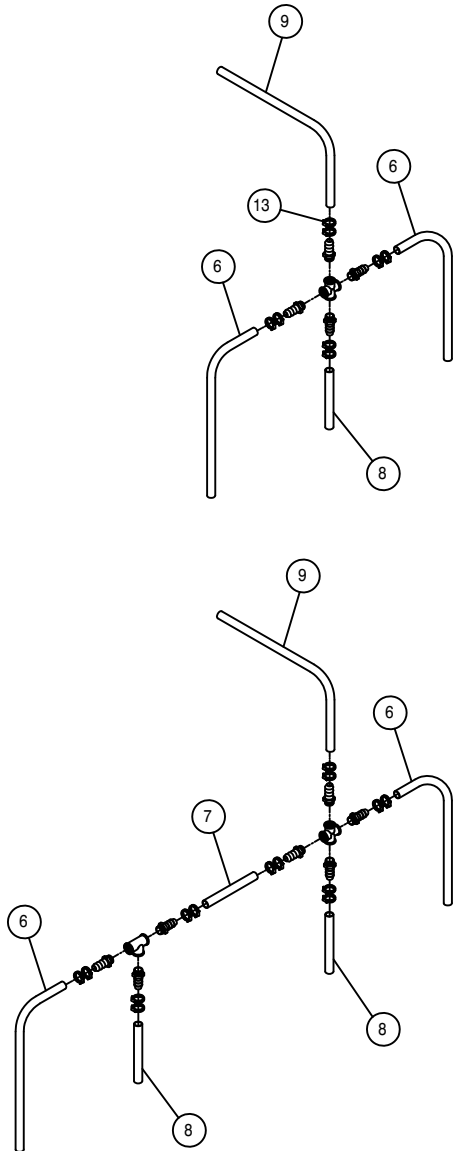

6-DROP HOSING

11-DROP HOSING

6 AND 11 DROP HOSING

DET. QTY PART NO. DESCRIPTION

1	2	507736	1/2FNPT PIPE TEE SS
2	6	507738	3/4FNPT PIPE CROSS SS
3	6	618281	1/2MNPT X 1/2 HOSE INSERT
4	6	713220	HOSE BARB 3/4 NPT X 3/4
5	18	714350	HOSE BARB 3/4 NPT X 1/2
6	12	601199	HOSE, 1/2 X 105 2BR BLK EPDM
7	2	601601	HOSE, 1/2 X 70 2BR BLK EPDM
8	8	601333	HOSE, 1/2 X 48 2BR BLK EPDM
9	2	601339	HOSE, 3/4 X 216 2BR BLK EPDM
10	2	601337	HOSE, 3/4 X 96 2BR BLK EPDM
11	2	601340	HOSE, 3/4 X 276 2BR BLK EPDM
12	48	520055	HOSE CLAMP NO 12 STAINLESS
13	12	520090	HOSE CLAMP NO 16 STAINLESS

This Page Intentionally Blank

# NOTICE

---

The following page contains decals for the model 284 TXP.

These decals can be obtained from Hagie Mfg. Co. and should be used whenever your machine is repainted or when the decals become worn, weathered, or faded.

Special attention should be paid to decals involving personal safety. They have been attached for your protection.

**KEEP THEM IN PLACE.**

**Contact: Hagie Manufacturing Co.  
Box 273  
Clarion, Iowa 50525**



284TXP DECALS

QTY.	PART NO.	DESCRIPTION	LOCATION
1	650831	EMERGENCY STOP DECAL	ON LOWER LH FRONT CAB FOAM
1	650320	EMERGENCY EXIT DECAL	ON LOWER REAR OF EXIT WINDOW
1	650375	CONSOLE COVER PANEL DECAL	ON CONSOLE SHEET METAL
1	650340	PARK BRAKE DECAL	NEAR PARK SWITCH
1	650822	SOLUTION PUMP DECAL	ON FRONT CROSSMEMBER
1	650847	NO PASSENGER DECAL	REAR CORNER OF CAB
2	650848	SLIP OR FALL DECAL	2-ON EACH FUEL TANK
2	650849	ENGINE FUEL DECAL	NEAR EACH FUEL TANK NECK
2	650850	CHEMICAL DECAL	ON SOLUTION TANK LIDS
2	650851	SHIELDS DECAL	ON SIDE OF TOP ENGINE COVER
1	650852	READ MANUAL DECAL	ON LOWER LH FRONT CAB FOAM
1	650326	HAGIE DECAL	ON FRONT MAINFRAME SHIELD
2	650954	DIESEL DECAL	NEAR EACH FUEL NECK
1	650981	COOLING SYSTEM DECAL	NEAR RADIATOR CAP
1	650982	ELECTRICAL DECAL	RIGHT HAND SIDE OF OIL TANK
4	650985	WHEEL BOLT TORQUE DECAL	ON EACH WHEEL RIM
1	650323	DECAL SET, HAGIE 284 STRIPE	ON EACH ENGINE HOOD
2	650324	DECAL STRIPE, 3 X 72	ON EACH TANK SHIELD
1	650329	SPRAY CONTROL/TRAC DECAL	ON INSTRUMENT PANEL
1	650336	FOLD BOOM WARNING DECAL	ON LOWER REAR OF EXIT WINDOW
1	650337	ELECTROCUTION HAZARD DECAL	ON LOWER REAR OF EXIT WINDOW
1	650339	HYDRAULIC OIL INJ. DECAL	ON LOWER REAR OF EXIT WINDOW
1	650347	NOTICE-R134A CHARGE DECAL	NEXT TO A/C COMPRESSOR
1	650348	NOTICE-DRAIN AIR TANK DECAL	ON AIR TANK
2	650373	TXP DECAL	ON EACH ENGINE HOOD
1	650367	AIR FILTER INSTRUCTION DECAL	ON ENGINE AIR FILTER END CAP

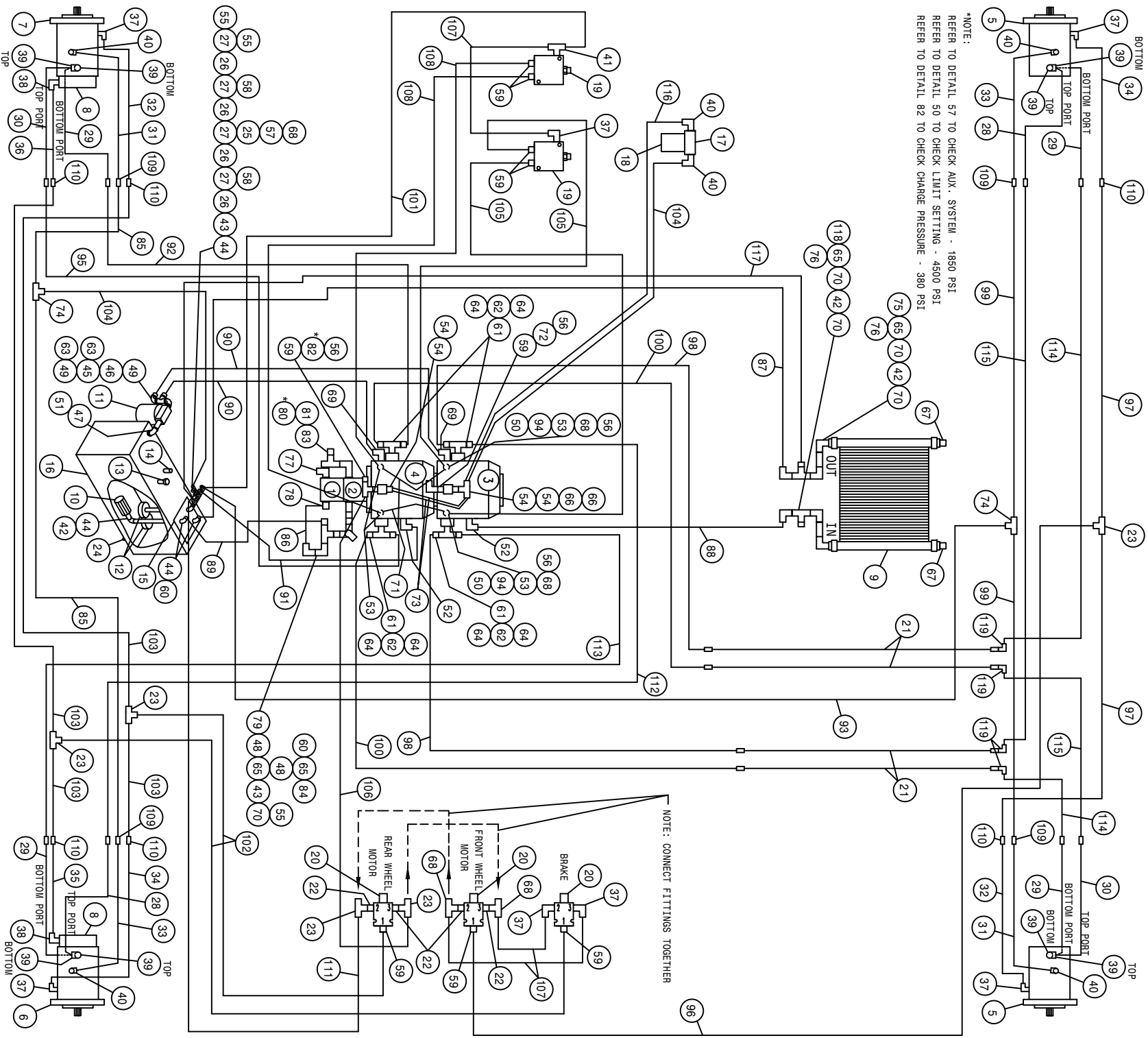

NOTE: CONNECT FITTINGS TOGETHER

\*NOTE:  
 REFER TO DETAIL 57 TO CHECK AUX. SYSTEM - 1850 PSI  
 REFER TO DETAIL 50 TO CHECK LIMIT SETTING - 4500 PSI  
 REFER TO DETAIL 82 TO CHECK CHARGE PRESSURE - 380 PSI

284TXP HYDRAULIC SCHEMATIC 2004  
REFERENCE DRAWING NO. 498809S1

DET.	QTY	PART NO.	DESCRIPTION	DET.	QTY	PART NO.	DESCRIPTION
1	1	606929	SUND GEAR PUMP .66CI, SPLINED	61	4	618598	1" 4-BOLT FLG X 1 5/16 FOR
2	1	606932	SUND GEAR PUMP,1.60CI,SPLINED	62	4	618599	1 5/16MOR BRANCH TEE-1 5/16MJ
3	1	606944	SUND 75CC PUMP,C/C-MT	63	2	715664	1 1/4 NPT X 1 HOSE BARB
4	1	606947	SUND 75CC PUMP,C/B-MT	64	8	618640	1 5/16MJ-90-1 5/16FJ SWIV LBO
5	2	610637	SUND HYD MOTOR, M46-4019	65	4	505101	BLK PIPE TEE 1.00NPT
6	1	610640	SUND HYD MOTOR, M46-4144	66	2	618643	3/4FJ SW BRANCH TEE-3/4MJ
7	1	610643	SUND HYD MOTOR, M46-4199 W/SEN	67	2	505102	PIPE PLUG 1.00NPT SQ HD
8	2	828093	MICO HYD BRAKE	68	5	618486	9/16FJIC SW RUN TEE-9/16MJIC
9	1	618606	OIL COOLER, BLISSFIELD 65027	69	2	618564	1IN HOSE BARB-90-1 5/16MOR
10	1	605600	TANK FILTER, 100 MESH,1"FNPT	70	5	505200	BLK PIPE ST EL 90DEG 1.00NPT
11	1	605601	PARKER FILTER ASSY,10M,1.25NPT	71	2	615734	04C2AT-06FJX-06FJX-11
12	2	605603	LINE SUMP DIFFUSER	72	1	618618	9/16MJIC-90-9/16FJIC SWIV LBO
13	1	611052	FILLER BREATHER 3/4NPT	73	2	614739	08C1T-08FJX-08FJX-90-16
14	1	614453	DIPSTICK, 8IN	74	2	618311	3/4MJIC UNION TEE
15	1	760090	RECEIVER PLT WLD 8240	75	1	618138	1IN HOSE BARB-90-1MNPT
16	1	760264	HYD TANK WLD,204/254/284 2002	76	2	714331	1 NPT X 3/4 HOSE BARB
17	1	605608	HYD FILTER HEAD, DONALDSON	77	1	611128	7/8MJIC-90-7/8MOR LBO
18	1	605609	HYD FILTER ELEMENT, DONALDSON	78	1	618075	3/4 HOSE BARB-1 1/16MOR
19	2	610580	REMOTE FLUSHING VALVE, SUND	79	1	618090	1 5/16MOR-1FNPT ADPTR
20	3	606138	HYD SOLE VLV,2P-3W,9/16FOR, WP	80	1	618328	7/8FJIC CAP NUT
21	4	615724	FRT MAIN HYD TUBE ASSY,2100 98	81	1	618333	7/8FJIC SW RUN TEE-7/8MJIC
22	4	618668	9/16FJIC SWIV-9/16MOR ADPTR	82	1	618514	9/16FJ SW BRANCH TEE-9/16MJ
23	5	618019	9/16MJIC UNION TEE	83	1	618535	7/8MJIC-90-1 1/16MOR LBO
24	1	470308	1/2MNPT DRAIN PLUG,AL HD,MAG	84	1	716000	3/4 HOSE BARB-90-1MNPT
25	1	504001	RED BUSH 3/4 X 1/4 BLK MAL	85	2	614689	08C1T-08FJX-08FJX-120
26	4	504702	CLOSE NIPPLE .75NPT	86	1	601399	HOSE, 3/4 X 13 IFBR-1SPI
27	4	504955	BLK PIPE TEE .75NPT	87	1	601404	HOSE, 1 X 87 IFBR-1SPI
28	2	615808	UPR HYD TUBE ASSY,LEG 2100 03	88	1	601385	HOSE, 3/4 X 65 IFBR-1SPI
29	4	615708	LMR HYD TUBE ASSY,LEG 2100 98	89	1	601594	HOSE, 1 X 56 IFBR-1SPI
30	2	615709	UPR HYD TUBE ASSY,LEG 2100 98	90	2	601596	HOSE, 1 X 30 IFBR-1SPI
31	2	615710	RF/LR HYD DRN TUBE ASSY2100 98	91	1	601595	HOSE, 3/4 X 28 IFBR-1SPI
32	2	615712	RF/LR HYD CTRL TUBE ASSY210098	92	1	616196	12TWM-16FJX-16MJ-126
33	2	615809	LF/RR HYD DRN TUBE ASSY2100 03	93	1	616194	08C2AT-08FJX-08FJX-90-144
34	2	615713	LF/RR HYD CTRL TUBE ASSY210098	94	2	618291	9/16FJX-1/4FNPT ADPTR
35	1	615714	RH HYD BRAKE TUBE ASSY,2100 98	95	1	616198	12TWM-16FJX-16MJ-138
36	1	615715	LH HYD BRAKE TUBE ASSY,2100 98	96	1	616191	04C1T-06FJX-06FJX-138
37	7	618119	9/16MJIC-90-9/16MOR LBO	97	2	615730	04C1T-06FJX-06FJX-150
38	2	618114	9/16MJIC-90-7/16MOR LBO	98	2	616199	12TWM-16FJX-12MJ-42
39	8	618178	1 5/16MJIC-90-1 5/16MOR LBO	99	2	616193	08C1T-08FJX-08FJX-148
40	6	618474	3/4MJIC-90-1 1/16MOR LBO	100	2	616200	12TWM-16FJX-12MJ-55
41	1	618444	9/16MOR RUN TEE-9/16MJIC	101	1	616048	04C1T-06FJX-06FJX-35
42	3	505203	BLK PIPE NIPPLE 1.00NPT-4.00	102	2	616036	04C1T-06FJX-06FJX-12
43	2	505213	RED BUSH 1 X 3/4 BLK MAL	103	4	614076	04C1T-06FJX-06FJX-119
44	4	505300	BLK PIPE EL 90DEG 1.00NPT	104	2	616034	08C1T-08FJX-08FJX-17
45	1	506105	BLK PIPE TEE 1.25NPT	105	2	616255	04C2AT-06FJX-06FJX-29
46	1	506200	CLOSE NIPPLE 1.25NPT	106	1	614715	04C1T-06FJX-06FJX-43
47	1	506303	BLK PIPE EL 90DEG 1.25NPT	107	3	616042	04C1T-06FJX-06FJX-13
48	2	505105	1MNPT HEX PIPE NIPPLE STL	108	2	616254	04C2AT-06FJX-06FJX-26
49	2	506410	BLK PIPE ST EL 90DEG 1.25NPT	109	4	618314	3/4MJIC UNION
50	2	614740	RESTRICTOR FTG ASSY,.050	110	6	619010	9/16MJIC UNION
51	1	506602	PIPE NIPPLE 1 1/4NPT-2 1/2	111	1	614663	04C1T-06FJX-06FJX-16
52	2	618118	3/4 HOSE BARB-90-1 1/16MOR	112	1	616197	12TWM-16FJX-16MJ-132
53	4	618629	9/16MOR BRANCH TEE-9/16MJIC	113	1	616195	12TWM-16FJX-16MJ-110
54	4	618327	3/4MJIC-7/8MOR ADPTR	114	2	616202	12TWM-12MJ-16MJ-134
55	3	610300	3/4MJIC-3/4MNPT ADPTR	115	2	616201	12TWM-12MJ-16MJ-166
56	4	618531	9/16FJIC CAP NUT	116	1	616192	08C1T-08FJX-08FJX-21
57	1	618520	1/4MNPT RUN TEE-9/16MJIC	117	1	601401	HOSE, 3/4 X 88 IFBR-1SPI
58	2	713220	HOSE BARB 3/4 NPT X 3/4	118	1	716000	3/4 HOSE BARB-90-1MNPT
59	9	618126	9/16MJIC-9/16MOR ADPTR	118	1	716000	3/4 HOSE BARB-90-1MNPT
60	3	714560	1NPT X 1 HOSE BARB	119	4	618191	1 1/16MJ-90-1 1/16FJ SWIV LBO

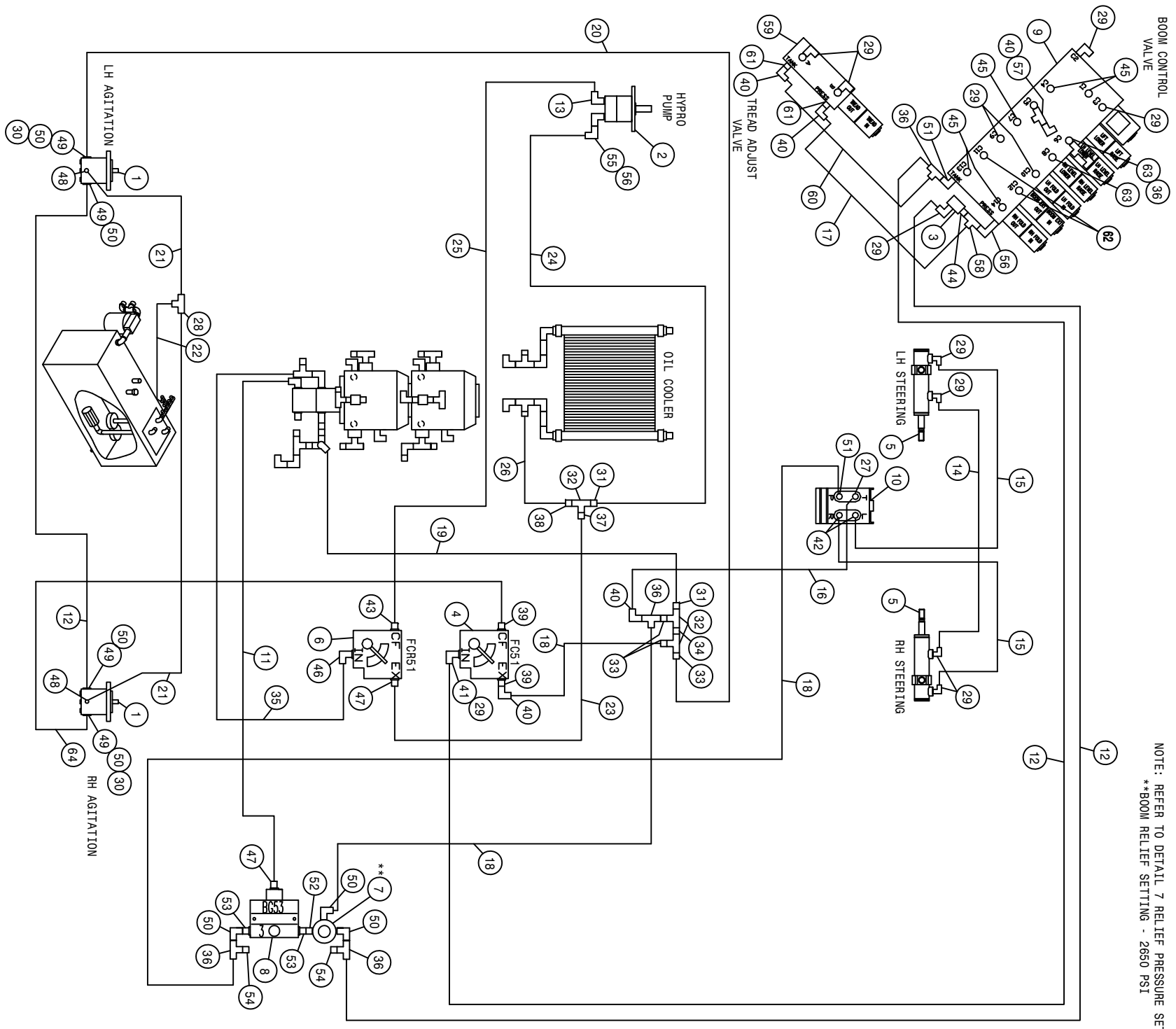

NOTE: REFER TO DETAIL 7 RELIEF PRESSURE SETTING.  
 \*\*BOOM RELIEF SETTING - 2650 PSI

284TXP HYDRAULIC SCHEMATIC 2004  
REFERENCE DRAWING NO. 498809S2

DET.	QTY	PART NO.	DESCRIPTION	DET.	QTY	PART NO.	DESCRIPTION
1	2	610510	CESSNA GEAR MOTOR 1.48CI	33	618018	9/16MJIC-1/2MNPT ADPTR	
2	1	695985	CHAR LYNN 2000 HYD MTR, 6.1CI	34	503600	CLOSE NIPPLE .50NPT	
3	1	605615	HYD FILTER, INLINE 25M 9/16FOR	35	616204	10CIT-10FJX-10FJX-113	
4	1	606827	FLO CONT FCS1 0-3 VARI 7/8FOR	36	618486	9/16FJIC SW RUN TEE-9/16MJIC	
5	2	621512	STEERING CYL ASSY, 2.00 X 6.28	37	618325	7/8MJIC-1/2MNPT ADPTR	
6	1	606818	FLO CONT FCR51 0-16GPM 7/8FOR	38	712440	1/2 NPT X 3/4 HOSE BARB	
7	1	607512	RELIEF VALVE, RL50, 1850 PSI	39	618310	9/16MJIC-7/8MOR ADPTR	
8	1	610307	FLO DIV BG53 3GPM PRI 7/8FOR	40	618618	9/16MJIC-90-9/16FJIC SWIV LBO	
9	1	606102	BOOM VLV, X11/284/2100 PWRSYS03	41	618172	7/8MOR-9/16FOR ADPTR	
10	1	749318	STRG MTR, 7.3CID, NON-LOAD 1031	42	618109	9/16MJIC-3/4MOR ADPTR	
11	1	616203	10CIT-10FJX-10FJX-110	43	618327	3/4MJIC-7/8MOR ADPTR	
12	3	614693	06CIT-06FJX-06FJX-168	44	618692	3/4FJIC SWIV-9/16MOR ADPTR	
13	1	618183	3/4MJIC-90-7/8MOR LBO	45	618126	9/16MJIC-9/16MOR ADPTR	
14	1	616206	04CIT-06FJX-06FJX-216	46	611128	7/8MJIC-90-7/8MOR LBO	
15	2	616205	04CIT-06FJX-06FJX-117	47	611126	7/8MJIC-7/8MOR ADPTR	
16	1	616172	04CIT-06FJX-06FJX-60	48	618338	9/16MJIC-45-1/4MNPT LBO	
17	1	615473	06CIT-06FJX-08FJX-18	49	618092	1 1/16MOR-1/2FNPT ADPTR	
18	3	616026	04CIT-06FJX-06FJX-37	50	618107	9/16MJIC-90-1/2MNPT LBO	
19	1	616057	08CIT-08FJX-08FJX-88	51	618115	9/16MJIC-90-3/4MOR LBO	
20	1	614571	06CIT-06FJX-06FJX-126	52	500000	1/2MNPT HEX PIPE NIPPLE STL	
21	2	611204	04CIT-06FJX-06FJX-78	53	618072	7/8MOR-1/2FNPT ADPTR	
22	1	615452	06CIT-06FJX-06FJX-16	54	618531	9/16FJIC CAP NUT	
23	1	615521	10CIT-10FJX-10FJX-18	55	618171	7/8MOR-3/4FOR ADPTR	
24	1	614382	08CIT-08FJX-08FJX-40	56	618241	3/4MJIC-90-3/4MOR LBO	
25	1	614662	08CIT-08FJX-08FJX-72	57	618444	9/16MOR RUN TEE-9/16MJIC	
26	1	601384	HOSE, 3/4 X 40 1FBR-1SPI	58	618451	3/4FJIC SW RUN TEE-3/4MJIC	
27	1	618709	9/16MJIC-90-3/4MOR EX LG LBO	59	606100	TREAD ADJ VLV, 284/XP, PWRSYS 03	
28	1	618019	9/16MJIC UNION TEE	60	615620	06CIT-06FJX-06FJX-18	
29	12	618119	9/16MJIC-90-9/16MOR LBO	61	618126	9/16MJIC-9/16MOR ADPTR	
30	2	618634	9/16MJIC-45-9/16FJIC SWIV LBO	62	610185	9/16MOR PLUG	
31	2	611147	3/4MJIC-1/2MNPT ADPTR	63	614763	9/16MJIC-9/16MOR, .042 CHK ADPT	
32	3	503820	BLK PIPE TEE .50NPT	64	614704	06CIT-06FJX-06FJX-156	

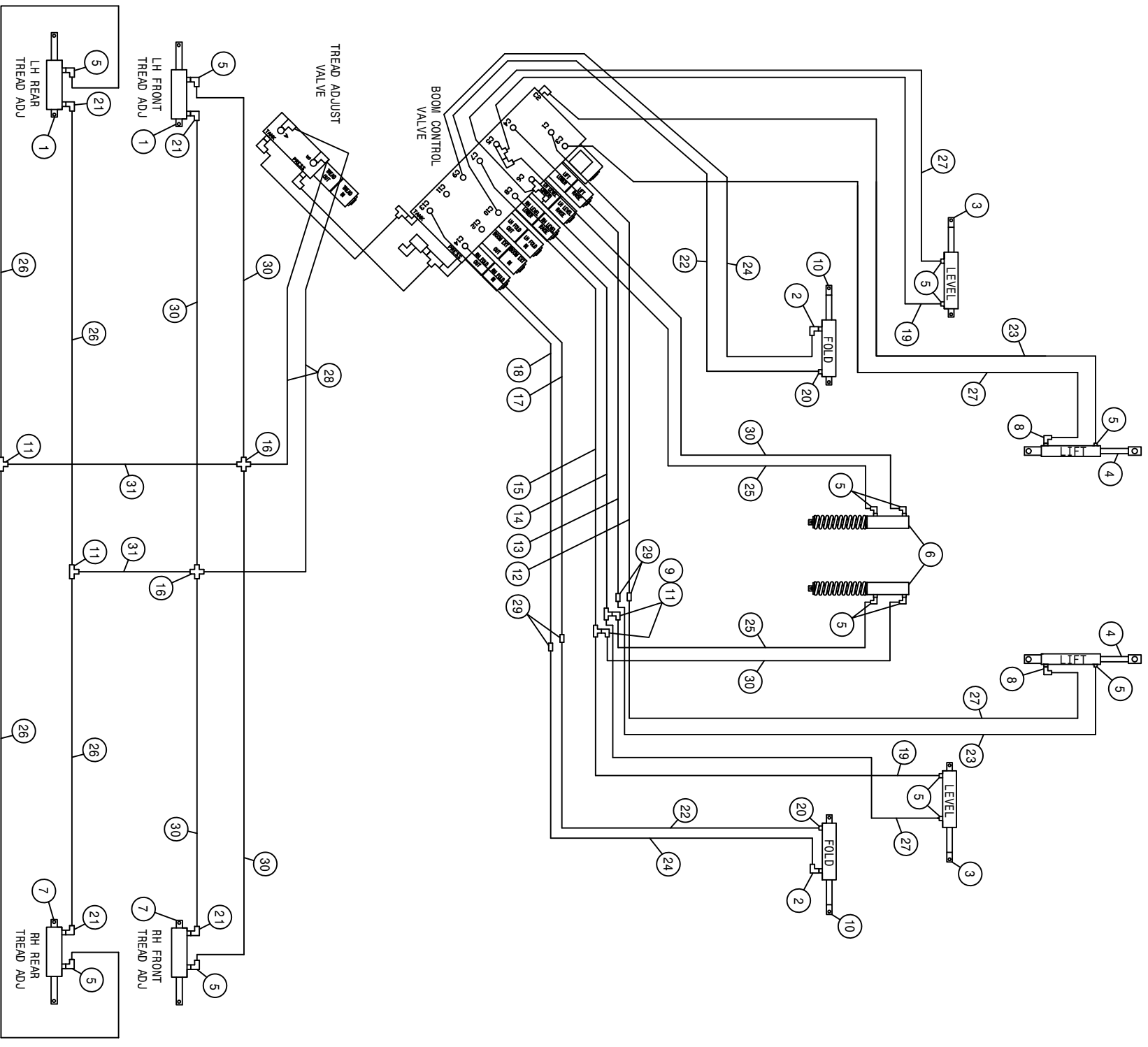

284TXP HYDRAULIC SCHEMATIC 2004  
REFERENCE DRAWING NO. 498809S3

DET.	QTY	PART NO.	DESCRIPTION	DET.	QTY	PART NO.	DESCRIPTION
1	2	621534	LH TRD ADJ CYL,DTS8T-DTS10 04	17	1	615790	RH FOLD RAISE HYD TUBE ASSYX11
2	2	618688	9/16MOR-90-9/16MJ .025 CHK VLV	18	1	615791	RH FOLD LOWER HYD TUBE ASSYX11
3	2	621522	BOOM LEVEL CYL ASSY	19	2	616172	04C1T-06FJX-06FJX-60 H/A
4	2	621518	TRANSOM LIFT CYL ASSY	20	2	614750	.042 ELBOW ASSY,9/16MOR 90D
5	14	618119	9/16MJIC-90-9/16MOR LBO	21	4	614747	.025 ELBOW ASSY,9/16MOR 90D
6	2	621524	ACCUMULATOR CYL ASSY	22	2	616207	04C1T-06FJX-06FJX-62 H/A
7	2	621536	RH TRD ADJ CYL,DTS8T-DTS10 04	23	2	616040	04C1T-06FJX-06FJX-67 H/A
8	2	618689	9/16MOR-90-9/16MJ .042 CHK VLV	24	2	615726	04C1T-06FJX-06FJX-73 H/A
9	2	618618	9/16MJIC-90-9/16FJIC SWIV LBO	25	2	616056	04C1T-06FJX-06FJX-32 H/A
10	2	621520	BOOM HINGE FOLD CYL ASSY	26	4	614715	04C1T-06FJX-06FJX-43 H/A
11	4	618019	9/16MJIC UNION TEE	27	4	616174	04C1T-06FJX-06FJX-70 H/A
12	1	615786	LIFT RAISE HYD TUBE ASSY X-11	28	2	611210	04C1T-06FJX-06FJX-156 H/A
13	1	615787	LIFT LOWER HYD TUBE ASSY X-11	29	4	619010	9/16MJIC UNION
14	1	615788	LEVEL RAISE HYD TUBE ASSY X-11	30	6	616026	04C1T-06FJX-06FJX-37 H/A
15	1	615789	LEVEL LOWER HYD TUBE ASSY X-11	31	2	611206	04C1T-06FJX-06FJX-66 H/A
16	2	618320	9/16MJIC UNION CROSS				

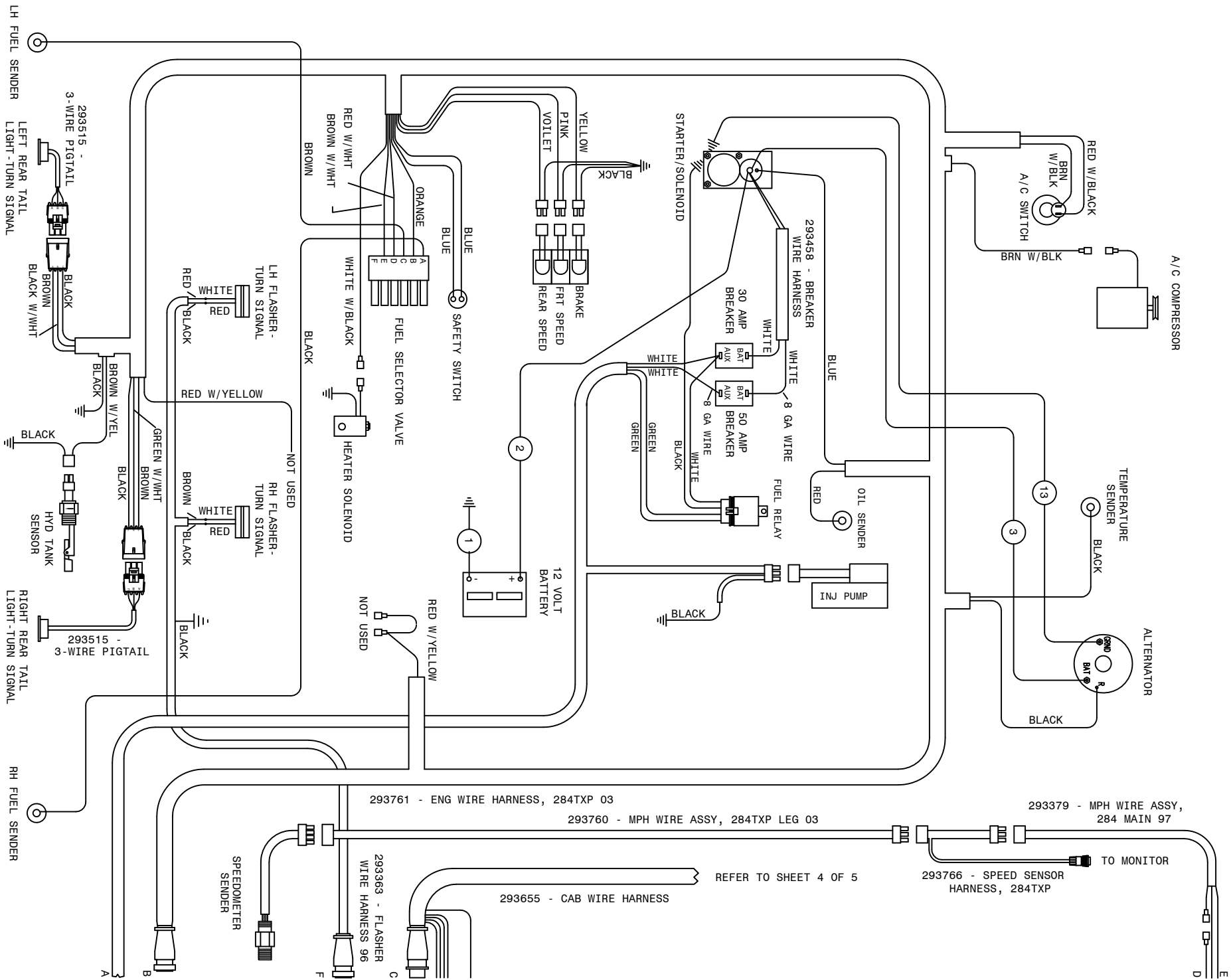



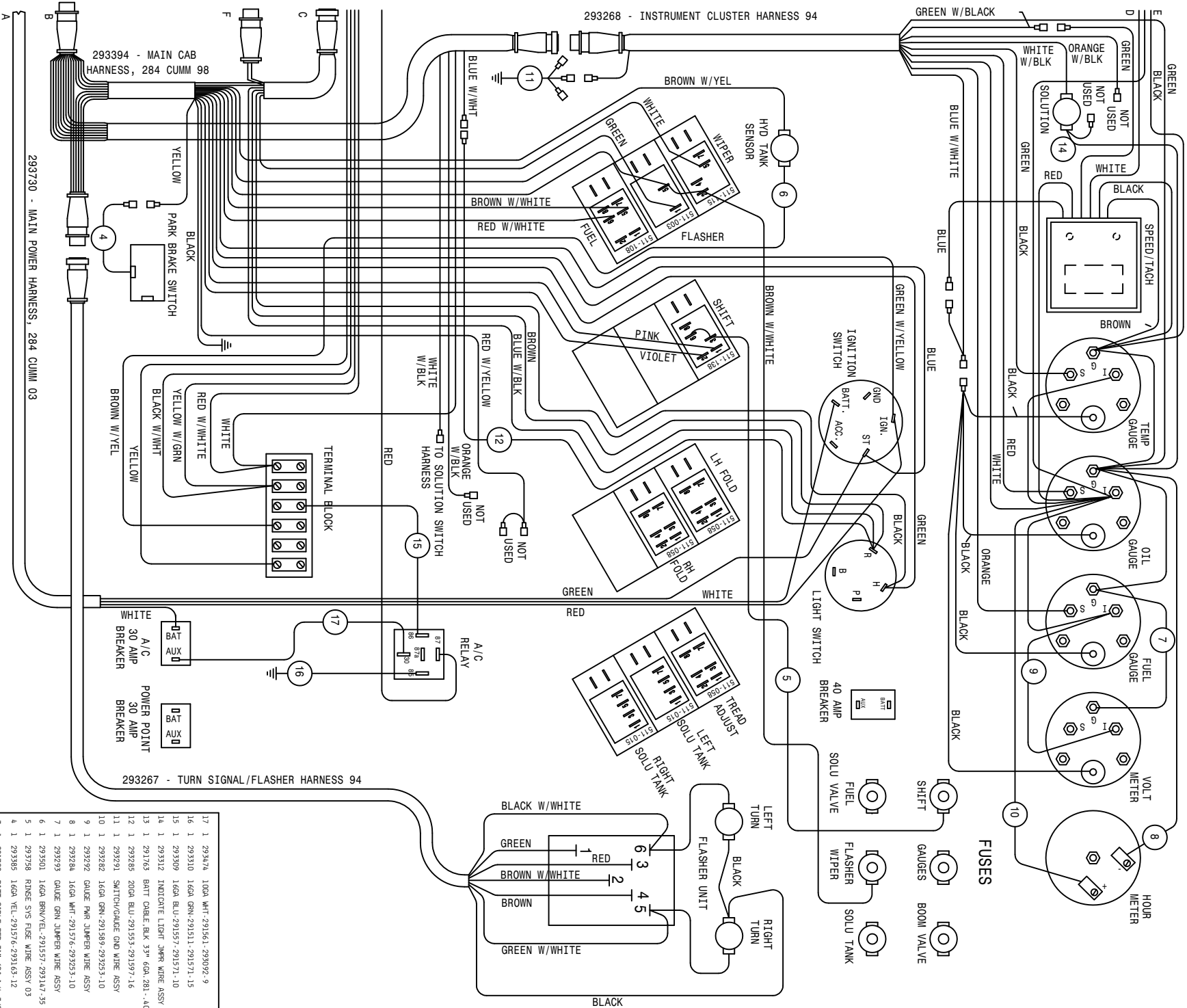

17	1	293474	10GA WHT-291561-293092-9
16	1	293310	16GA GRN-291511-291571-15
15	1	293309	16GA BLU-291557-291571-10
14	1	293312	INDICATE LIGHT JMR WIRE ASSY
13	1	291763	BATT CABLE BAK 35" 6GA, 201-, 406
12	1	293265	20GA BLU-291553-291597-16
11	1	293291	SWITCH/GAUGE GND WIRE ASSY
10	1	293282	16GA GRN-291589-292533-10
9	1	293292	GAUGE PWR JUMPER WIRE ASSY
8	1	293284	16GA WHT-291576-292533-10
7	1	293293	GAUGE GRN JUMPER WIRE ASSY
6	1	293501	16GA BRN/YEL-291557-293147-35
5	1	293158	RANGE SVS FUSE WIRE ASSY 03
4	1	293385	16GA YEL-291576-293163-12
3	1	291700	BATT CABLE RED 31" 6GA 1/4-3/8
2	1	291128	BATTERY GND CABLE 48IN
1	1	291530	BATTERY GROUND CABLE 23

284TYP WIRING DIAGRAM 04

07-11-03 TCM

SHEET 1 OF 5

REVISION DATE: 07-28-03

4988336

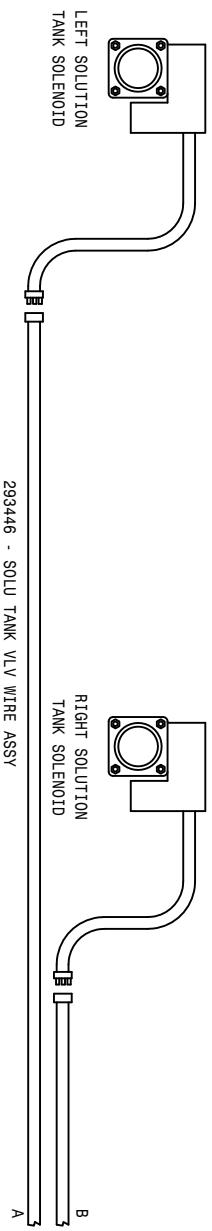

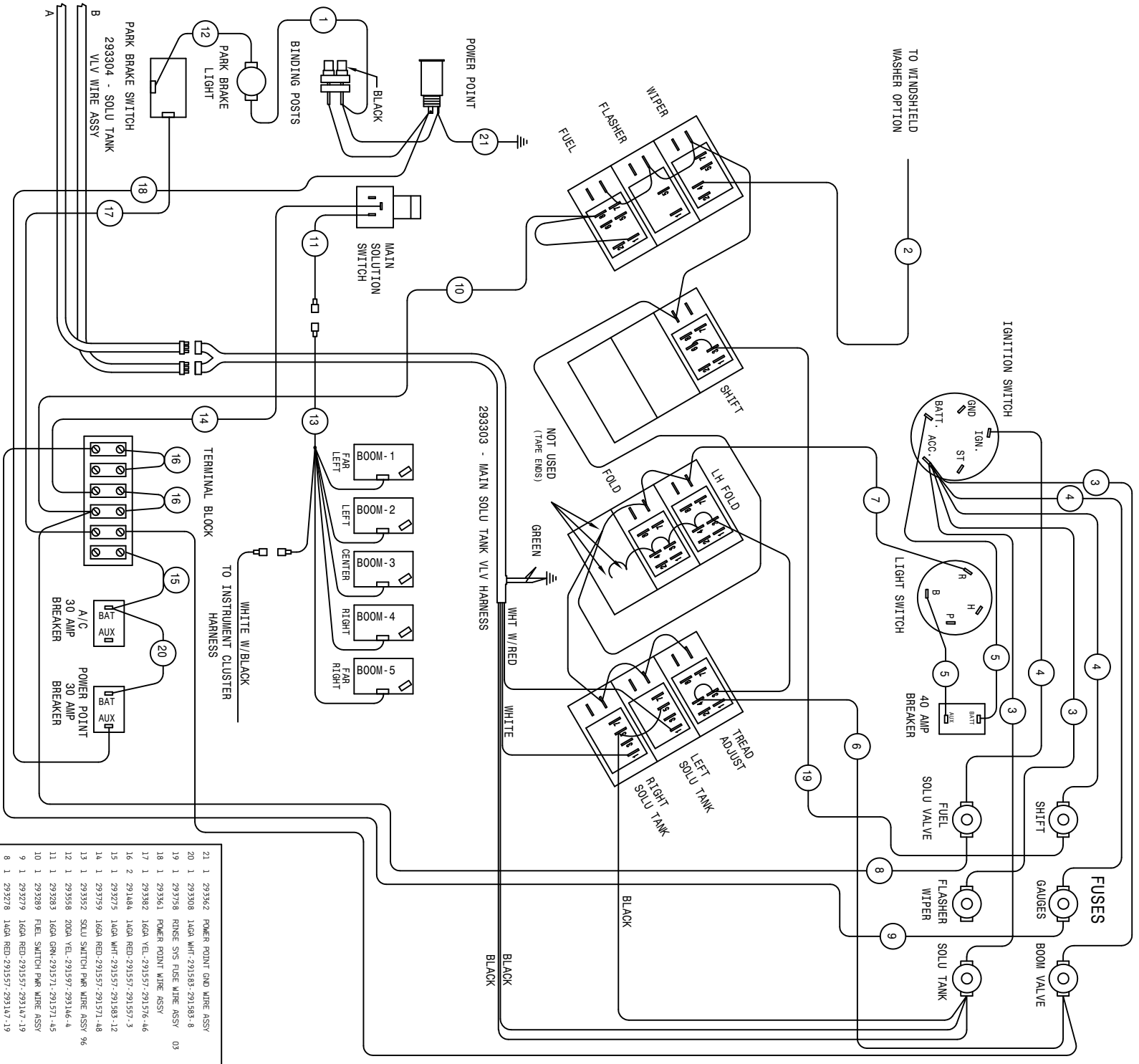

21	1	293362	POWER POINT GND WIRE ASSY
20	1	293508	16GA WHT-291583-291583-8
19	1	293758	RINSE SYS FUSE WIRE ASSY 03
18	1	293561	POWER POINT WIRE ASSY
17	1	293582	16GA YEL-29157-291576-46
16	2	291484	16GA RED-291597-291597-3
15	1	293275	16GA WHT-29157-291583-12
14	1	293759	16GA RED-29157-291571-48
13	1	293552	SOLU SWITCH PWR WIRE ASSY 96
12	1	293558	20GA YEL-291597-29146-4
11	1	293583	16GA GRN-291571-291571-45
10	1	293289	FILE SWITCH PWR WIRE ASSY
9	1	293279	16GA RED-29157-29147-19
8	1	293278	16GA RED-29157-29147-19
7	1	293756	MAIN SW LIGHT PWR WIRE ASSY 03
6	1	293351	MAIN SWITCH PWR WIRE ASSY 96
5	2	293274	12GA RED-291561-291561-25
4	3	293276	16GA RED-291583-29147-14
3	3	293277	16GA RED-291583-29147-18
2	1	293342	16GA RED-291599-291571-48
1	1	293557	20GA BLK-291597-29146-4

284TYP WIRING DIAGRAM 04  
 SHEET 2 OF 5  
 REVISION DATE: 10-01-03  
 498836  
 07-11-03 TLM

HYDRASTATIC CONTROL HANDLE

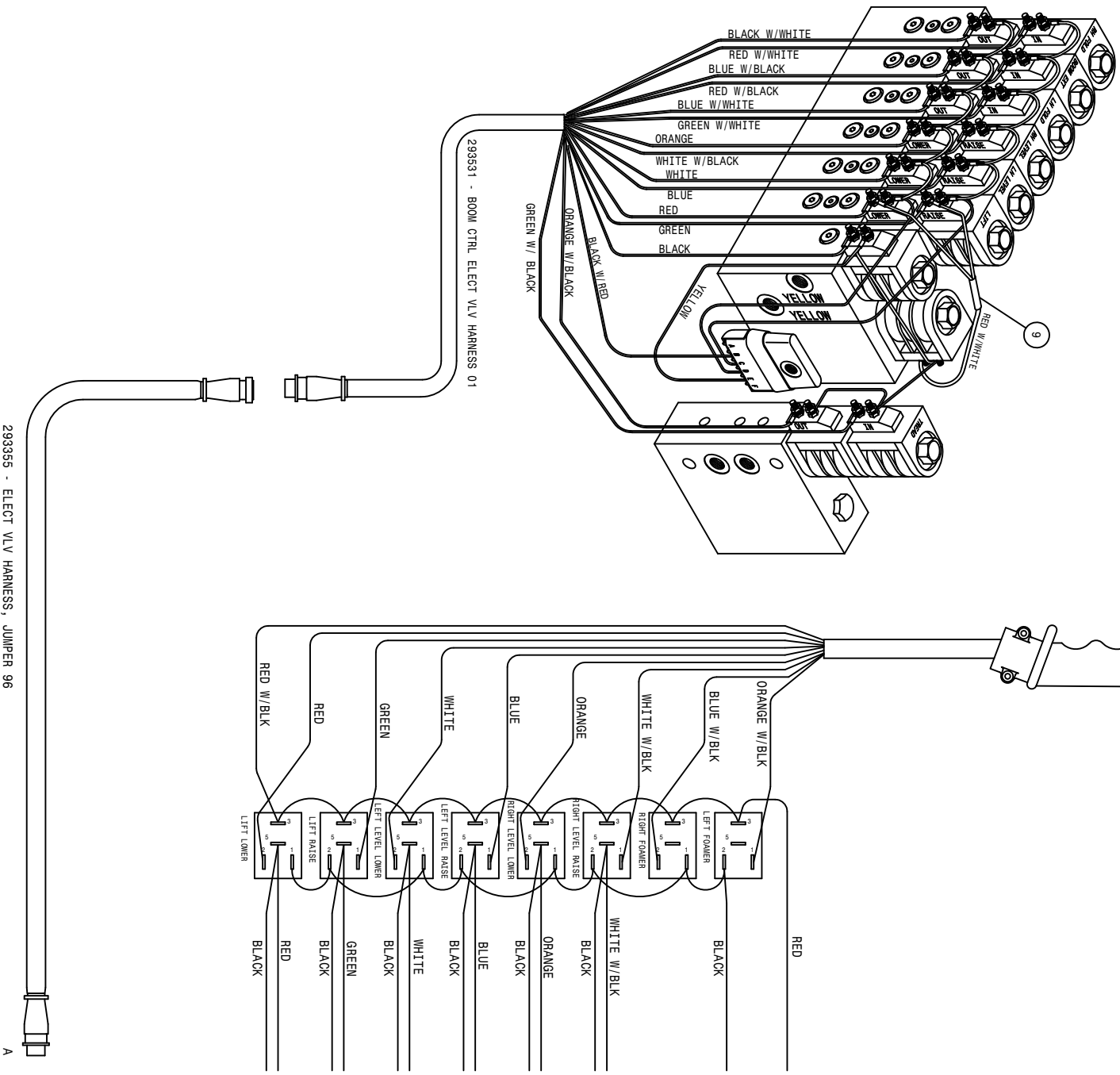

293355 - ELECT VLV HARNESS, JUMPER 96

293531 - BOOM CTRL ELECT VLV HARNESS 01

A

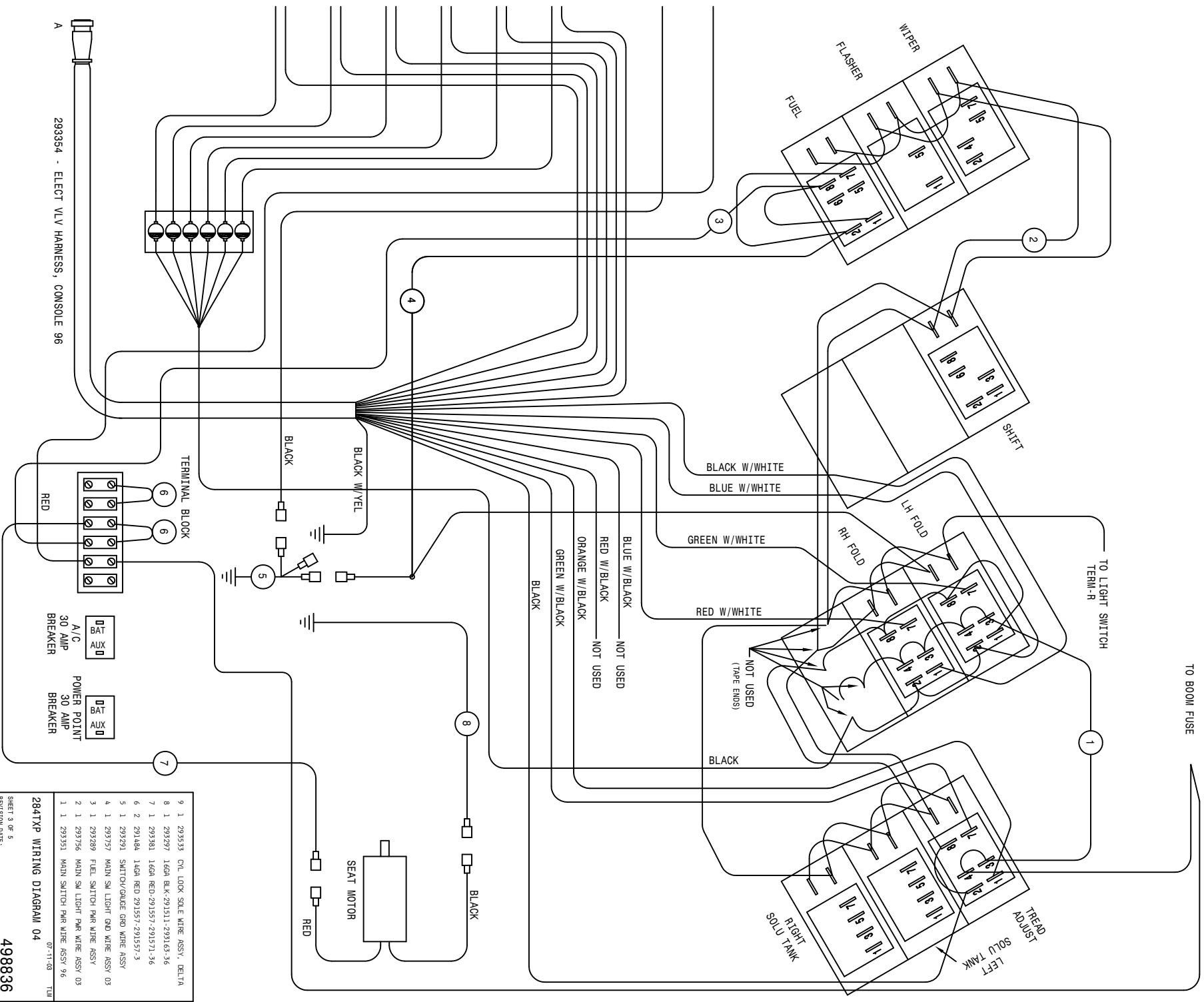

293354 - ELECT VLV HARNESS, CONSOLE 96

<b>2841XP WIRING DIAGRAM 04</b>			
SHEET 3 OF 5			
REVISION DATE: 07-11-08			
498836			

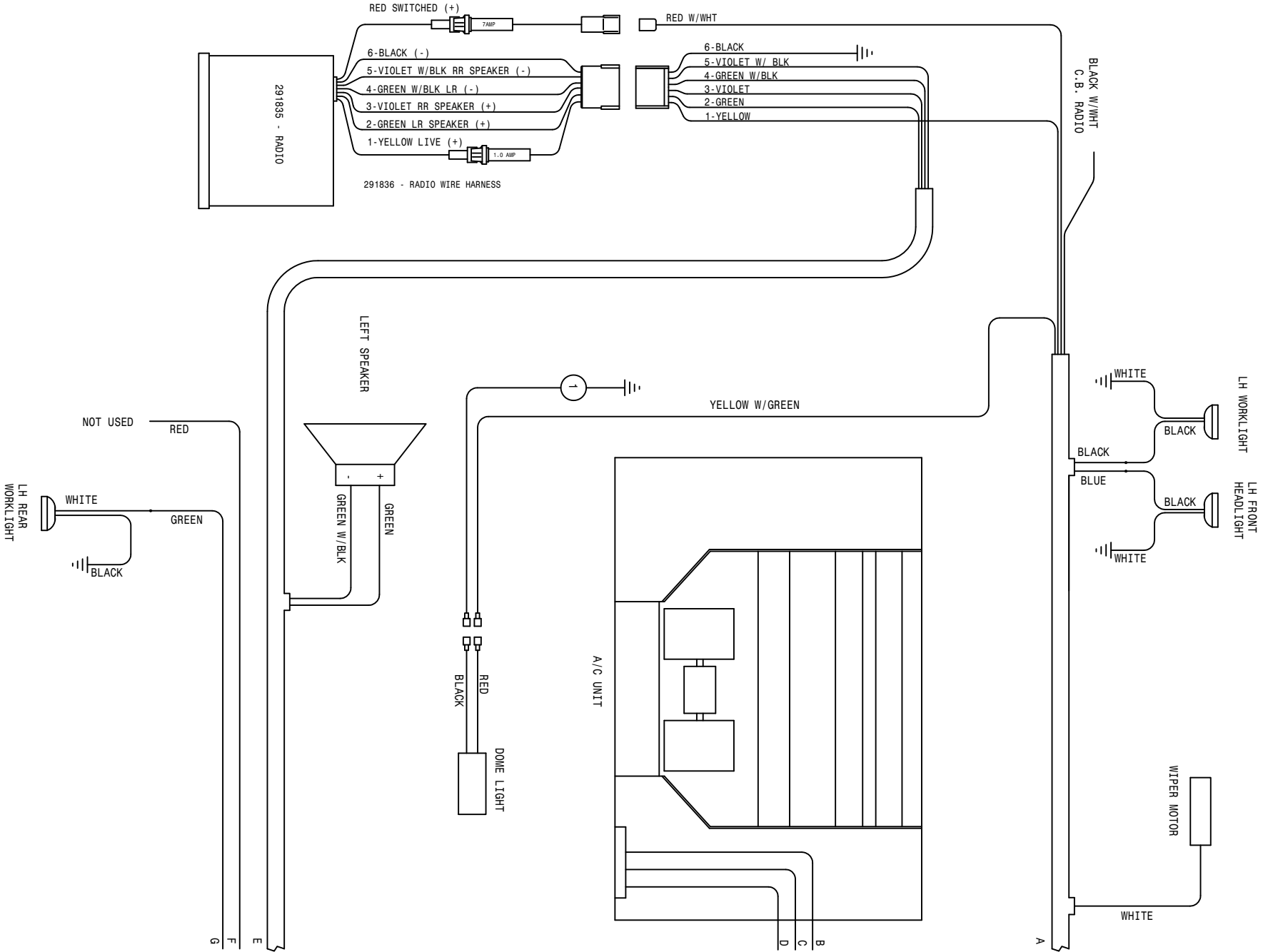

RH FRONT HEADLIGHT

RH WORKLIGHT

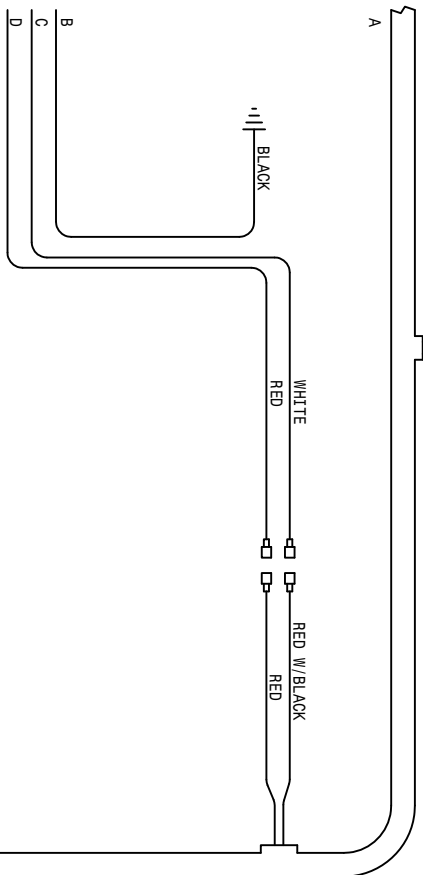

293655 - CAB WIRE HARNESS

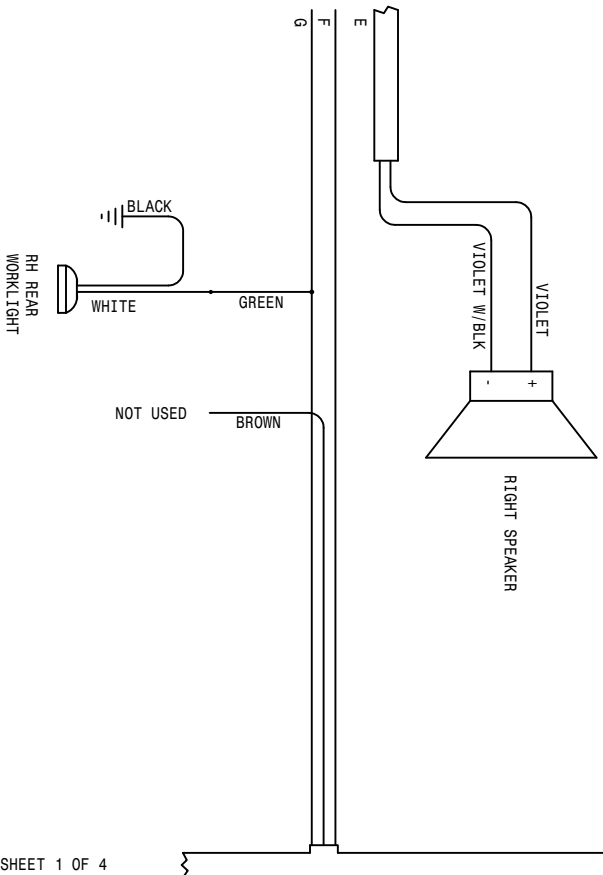

REFER TO SHEET 1 OF 4

1	1	293299	16GA BLK-291511-291571-30	07-11-08	TUN
284XP WIRING DIAGRAM 04					
SHEET 4 OF 5					
REVISION DATE:					
498836					

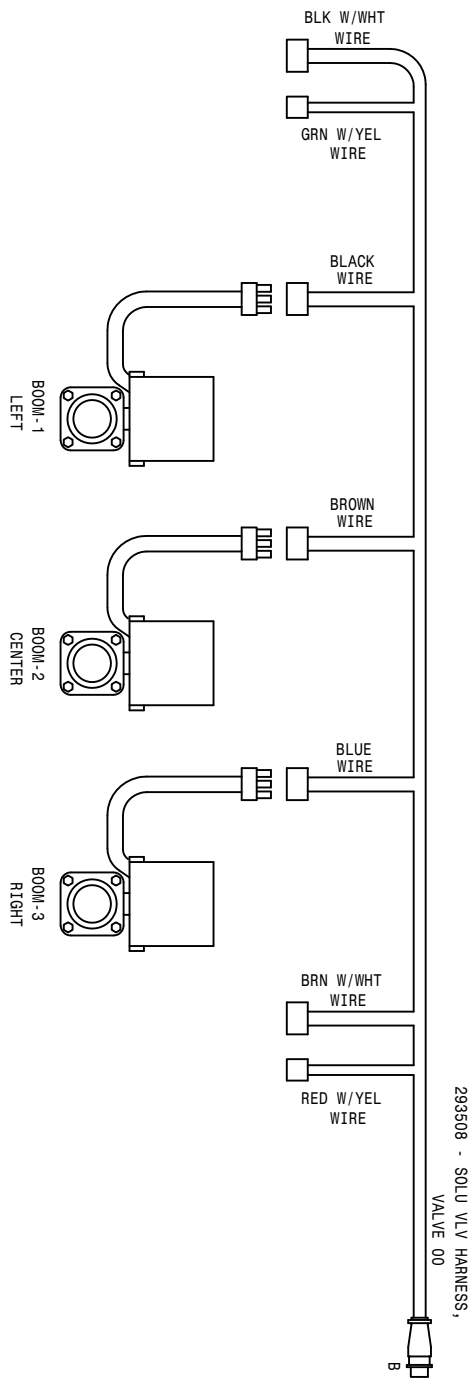
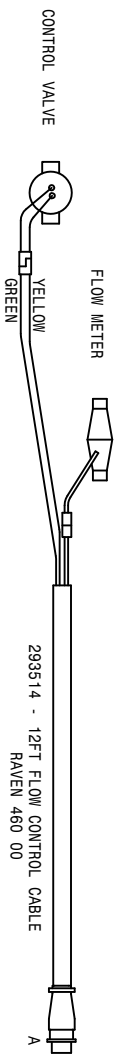

SOLUTION SOLENOID VALVES  
60 FOOT BOOM



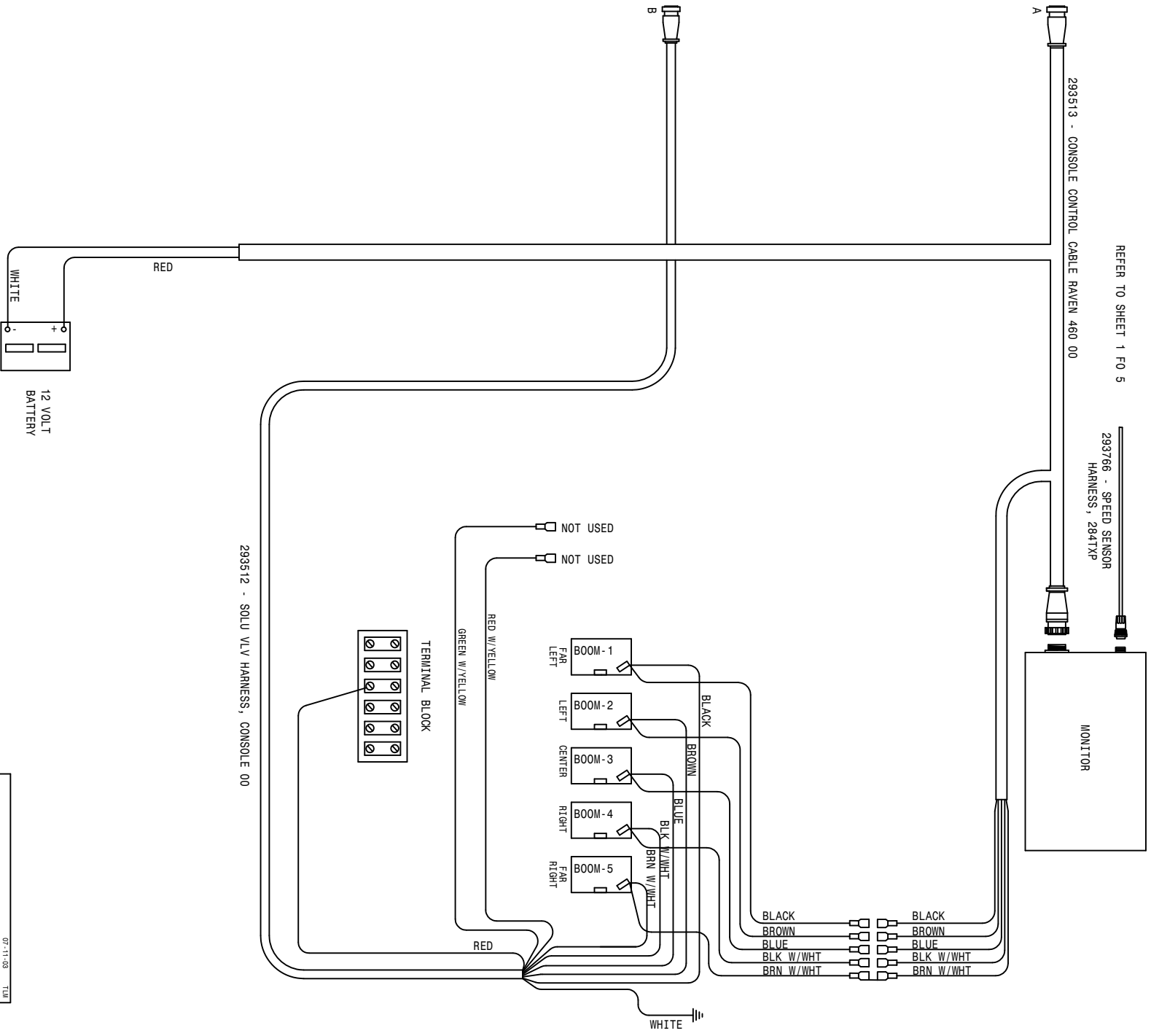

2841XP WIRING DIAGRAM 04  
 SHEET 5 OF 5  
 REVISION DATE: 07-29-03  
 493836  
 07-11-03 TLM

ABBREVIATIONS

A/C - AIR CONDITIONER	MT - MOUNT
ADPTR - ADAPTER	MTR - MOTOR
AGI - AGITATOR	P/N - PART NUMBER
ALT - ALTERNATOR	PLT - PLATE
ASSY - ASSEMBLY	QTY - QUANTITY
BRKT - BRACKET	RED - REDUCER
DET - DETAIL	REF - REFERENCE
DISPL - DISPLACEMENT	REST - RESTRICTOR
EL - ELBOW	REQ - REQUIRED
EXT - EXTENSION	SHFT - SHAFT
FLO - FLOW	SOL - SOLUTION
FNPT - FEMALE NATIONAL PIPE THREAD	STRG - STEERING
FOR - FEMALE O-RING	ST - STREET
FRT - FRONT	SWIV - SWIVEL
HYD - HYDRAULIC	UNC - UNIFIED NATIONAL COURSE
HYDRO - HYDROSTATIC	UNF - UNIFIED NATIONAL FINE
LG - LONG	V - VOLT
LWR - LOWER	W/ - WITH
MJIC - MALE J.I.C.	WHL - WHEEL
MOR - MALE O-RING	WLD - WELDMENT

INDEX

-A-

ABBREVIATIONS.....90  
 ACCUMULATOR CYLINDER.....60  
 ADJUSTMENT, TREAD.....66  
 AGITATOR  
   IMPELLER.....51,53  
   SHAFT.....51,53  
   SHIELD.....51,53  
   SOLUTION.....51,53  
 AIR CLEANER.....14  
   BAND.....14  
   FILTER.....14  
   HOOD.....14  
   HOSE.....14  
 AIR CONDITIONER  
   BLOWER MOUNT.....30  
   COMPRESSOR.....12  
   COMPRESSOR MOUNT.....12  
   CONDENSOR.....12  
   CONTROL.....30  
   DRYER.....12  
   FILTER.....30  
   AIR SEAT.....38  
   AIR TANK.....8,9  
   ANTENNA, RADIO.....30  
   ARM,  
   TANK SUPPORT.....49  
   WIPER.....28

-B-

BALL VALVE.....50,52  
 BAND,  
   AIR CLEANER.....14  
   FUEL TANK.....47  
   TANK.....50,52  
 BATTERY.....27  
   BOX.....27  
   CABLE.....27  
   BELT.....5,12  
   BINDING POST.....39  
   BLADE,  
   FAN.....5  
   WIPER.....28  
   BLOCK, TERMINAL.....35  
   BOOM.....64,65  
   CONTROL VALVE.....57  
   CRADLE.....43  
   PIVOT PIN.....59  
   SPRING.....64

BRACE,  
   LADDER.....46  
   LEG.....49  
 BRAKE SOLENOID.....41  
 BREAKAWAY.....59  
 BREAKER, CIRCUIT.....35  
 BREATHER.....16

-C-

CAB.....28  
   ROOF.....28  
 CABLE,  
   BATTERY.....27  
   CONTROL.....35,36,37,42  
   THROTTLE.....4  
 CAP,  
   FUEL.....47  
   RADIATOR.....13  
   STEERING.....32  
   CATWALK.....48  
   CIRCUIT BREAKER.....35  
   COMPRESSOR, A/C.....12  
   CONDENSOR.....12  
   MOUNT.....12  
   CONSOLE.....35  
   COVER.....34  
   CONTROL HANDLE.....36  
   COOLER, OIL.....13  
   CRADLE.....50,52  
   BOOM.....43  
   CROP GUIDE.....19,21,23,25  
   CYLINDER,  
   ACCUMULATOR.....60  
   FOLD.....63  
   LEVEL.....62  
   LIFT.....61  
   STEERING.....26  
   TREAD ADJUSTMENT.....68

-D-

DECALS.....72,73  
 DIAGRAM, WIRING.....80  
 DIFFUSER, LINE SUMP.....16  
 DIMMER SWITCH.....28  
 DIPSTICK.....16

DOOR.....29  
HANDLE.....29  
DRINK HOLDER.....35  
DRIVE ASSEMBLY.....4  
DRYER, A/C.....12

-E-

ENGINE.....4,5  
HOOD.....44  
MOUNTS.....4,5  
EXHAUST PIPE.....14

-F-

FAN  
BLADE.....5  
SPACER.....5  
FILTER,  
AIR CLEANER.....14  
AIR CONDITIONER.....30  
FUEL.....4  
HI-PRESS.....11  
INLINE HYDRAULIC.....57  
MICHIGAN.....16  
MINDER.....33  
OIL.....5,16  
FLASHER LIGHT.....43  
FLASHER SWITCH.....32  
FLOORMAT.....31  
FLOW CONTROL  
VALVE.....55  
VARIABLE.....42  
FLOW DIVIDER.....7  
FLOW METER.....55  
FLUSHING VALVE.....10  
FOAM.....13,31  
FOLD CYLINDER.....59,63  
FUEL  
CAP.....47  
GAUGE.....33  
SELECTOR VALVE.....47  
SENDER.....47  
TANK.....47  
FUSE.....34  
HOLDER.....34

-G-

GAUGE,  
FUEL.....33  
OIL PRESSURE.....33  
PRESSURE.....56  
SIGHT.....52

TEMPERATURE.....33  
GAS SPRING.....29  
GLASS.....28,29  
GLAND PACKING.....51,53  
GRAB HANDLE.....28  
GROUND STRAP.....4,15,28  
GUIDE, CROP.....19,21,23,25

-H-

HANDLE,  
CONTROL.....36  
DOOR.....29  
GRAB.....28  
HANDRAIL.....44,49  
HEADLIGHT.....28  
HEADLINER.....30  
HEAT SHIELD.....13  
HI-PRESS  
FILTER.....11  
HOLDER, DRINK.....35  
HOOD,  
AIR CLEANER.....14  
ENGINE.....44  
HOOK, RUBBER.....44  
HOSE, AIR CLEANER.....14  
HOSING, SOLUTION.....70  
HOUR METER.....33  
HUB, TORQUE.....19,21,23,25  
HYDRAULIC  
SCHEMATIC.....74  
TANK.....16  
TUBE.....15,19,21,23,25,58

-I-

IMPELLER.....51,53  
INDICATOR, MPH-RPM.....33  
INLINE HYDRAULIC FILTER.....57  
INTERIOR LIGHT.....30

-K-

KICK PANEL.....28  
KNOB.....34,35

-L-

LADDER.....46  
LEG,  
BRACE.....49  
FRONT.....18,19,20,21  
REAR.....22,23,24,25  
LEVEL CYLINDER.....59,62

LEVER,  
 HYDROSTATIC.....36  
 THROTTLE.....37  
 LID.....50,52  
 LIFTARM.....58  
 MOUNT.....58  
 LIFT CYLINDER.....58  
 LIGHT,  
 HEAD.....28  
 INTERIOR.....30  
 SWITCH.....34  
 TURN SIGNAL.....43  
 LINE SUMP DIFFUSER.....16

-M-

METER, HOUR.....33  
 MIRROR.....28  
 MOTOR  
 STEERING.....32  
 WHEEL.....19,21,23,25  
 WIPER.....28  
 MOUNT,  
 A/C BLOWER.....30  
 CONDENSOR.....12  
 ENGINE.....4,5  
 FLOW DIVIDER.....7  
 LIFTARM.....58  
 MONITOR.....40  
 RADIATOR.....13  
 RUBBER.....4,5,28  
 SOLUTION VFC.....42  
 TANK.....49  
 MUFFLER.....14  
 MULLION.....44

-N-

NOZZLE,  
 DROP.....69  
 NYLON SLEEVE.....18,20,22,24

-O-

OIL  
 COOLER.....13  
 FILTER.....5  
 PRESSURE GAUGE.....33  
 SENDER.....4  
 TANK.....16

-P-

PANEL, KICK.....28  
 PARK BRAKE SWITCH.....40  
 PIVOT PIN, BOOM.....59  
 PLATFORM, SERVICE.....48  
 POWER POINT.....40  
 PRESSURE GAUGE.....56  
 PUMP,  
 SOLUTION.....54  
 SUNDSTRAND.....6

-R-

RADIATOR.....13  
 CAP.....13  
 HOSE.....5  
 MOUNT.....13  
 SCREEN.....13  
 SHROUD.....13  
 RADIO.....30  
 RECOVERY.....13  
 RELAY.....36  
 RELIEF VALVE.....7  
 RIM.....17  
 ROOF, CAB.....28  
 RUBBER,  
 HOOK.....45  
 MOUNT.....4,5,28  
 WASHER.....7,41

-S-

SCHEMATIC, HYDRAULIC.....74  
 SCREEN.....45  
 RADIATOR.....13  
 SEAT.....39  
 SELECTOR VALVE, FUEL.....47  
 SENDER,  
 FUEL.....47  
 OIL.....4  
 TEMPERATURE.....5  
 SERVICE PLATFORM.....48  
 SHAFT, AGITATOR.....51,53  
 SHEETMETAL.....44,45  
 SHIELD,  
 AGITATOR.....51,53  
 HEAT.....13  
 SIDE.....45  
 TANK.....49  
 WHEEL MOTOR.....19,21,23,25  
 SHROUD, RADIATOR.....13

SIGHT GAUGE.....	50,52
SMV SIGN.....	48
SOLUTION	
AGITATOR.....	51,53
HOSING.....	70
PUMP.....	54
TANK.....	50,52
SPACER, FAN.....	5
SPEAKER.....	30
SPRING.....	37
BOOM.....	64
STALK GUIDE.....	19,21,23,25
STEERING	
ARM.....	18,20,22,24
CAB.....	32
CYLINDER.....	26
MOTOR.....	32
POST.....	32
WHEEL.....	32
STRAINER.....	50,52
STRAP, GROUND.....	4,15,28
SUNDSTRAND PUMP.....	6
SUPPORT ARM.....	49
SWITCH	
DIMMER.....	28
FLASHER.....	32
LIGHT.....	34
PARK BRAKE.....	40
TOGGLE.....	34

-T-

TAILLIGHT.....	48
TANK,	
AIR.....	8,9
BAND.....	50,52
FUEL.....	47
HYDRAULIC OIL.....	16
LID.....	50,52
MOUNTS.....	49
RECOVERY.....	13
SHIELD.....	49
SOLUTION.....	50,52
TEMPERATURE	
GAUGE.....	33
SENDER.....	5
TERMINAL BLOCK.....	35
THROTTLE	
CABLE.....	4
LEVER.....	37
TIRE.....	17

TOGGLE SWITCH.....	34
TORQUE HUB.....	19,21,23,25
TRANSOM.....	59
TREAD ADJUSTMENT.....	66
CYLINDER.....	68
TUBE,	
HYDRAULIC.....	58
4WD.....	41
TURN SIGNAL LIGHT.....	43
VALVE,	
BALL.....	50,52
BOOM CONTROL.....	55
ELECTRIC SOLUTION.....	50,52
FLOW CONTROL.....	55
FLUSHING.....	10
RELIEF.....	7
4WD.....	41
VARIABLE FLOW CONTROL.....	42
VOLTMETER.....	33

-W-

WEATHER STRIP, WINDOW.....	28,29
WHEEL MOTOR.....	19,21,23,25
SHIELD.....	19,21,23,25
WHEEL, STEERING.....	32
WINDSHIELD WASHER.....	40
WIPER	
ARM.....	28
BLADE.....	28
MOTOR.....	28
WIRING DIAGRAM.....	80



# PARTS ORDER FAX



Ph. 1 (800) 247-4885    Fx. 1 (515) 532-3553    Photocopy and fax to Hagie Customer Support Department

**ORDERED BY/BILL TO:**

Name \_\_\_\_\_  
Co. Name \_\_\_\_\_  
Street \_\_\_\_\_  
City, St, Zip \_\_\_\_\_  
Ph. \_\_\_\_\_ Fx. \_\_\_\_\_

**SHIP TO:**

Name \_\_\_\_\_  
Co. Name \_\_\_\_\_  
Street \_\_\_\_\_  
City, St, Zip \_\_\_\_\_  
Ph. \_\_\_\_\_ Fx. \_\_\_\_\_

HOW SHIP:    UPS Ground    Next Day    2 Day    3 Day    Other \_\_\_\_\_

If "HOW SHIP" is left blank, parts will be sent UPS ground service. If part is over 150 pounds, an independent motor freight company will be used.

**PAYMENT:**    Hagie Account #\*\*\* \_\_\_\_\_

C.O.D

American Express    Discover    Visa    Master Card  
Signature: \_\_\_\_\_  
name as appears on card: \_\_\_\_\_  
card no. \_\_\_\_\_ exp. date \_\_\_\_\_

Year and Model No. \_\_\_\_\_

Serial No. \_\_\_\_\_

Item Serial No. (if necessary): \_\_\_\_\_

Engine (include type) \_\_\_\_\_

Hydrostatic Pump (s) \_\_\_\_\_

Torque Hub \_\_\_\_\_       LF    RF    LR    RR

Wheel Motor \_\_\_\_\_       LF    RF    LR    RR

HAGIE Part No.	Qty.	Description

Check here if you want phone confirmation of parts order.

\* Orders received before 3:00 p.m., CST will be processed the same business day.

Regular business hours are Monday through Friday, 7:00 a.m. through 5:00 p.m..

\*\* If you do not have a Hagie account number, contact the Hagie Customer Support Department and you will be issued one.



# PARTS ORDER FAX



Ph. 1 (800) 247-4885    Fx. 1 (515) 532-3553

Photocopy and fax to Hagie Customer Support Department

**ORDERED BY/BILL TO:**

Name \_\_\_\_\_  
 Co. Name \_\_\_\_\_  
 Street \_\_\_\_\_  
 City, St, Zip \_\_\_\_\_  
 Ph. \_\_\_\_\_ Fx. \_\_\_\_\_

**SHIP TO:**

Name \_\_\_\_\_  
 Co. Name \_\_\_\_\_  
 Street \_\_\_\_\_  
 City, St, Zip \_\_\_\_\_  
 Ph. \_\_\_\_\_ Fx. \_\_\_\_\_

**HOW SHIP:**     UPS Ground     Next Day     2 Day     3 Day     Other \_\_\_\_\_

If "HOW SHIP" is left blank, parts will be sent UPS ground service. If part is over 150 pounds, an independent motor freight company will be used.

**PAYMENT:**     Hagie Account #\*\*\* \_\_\_\_\_

C.O.D

American Express     Discover     Visa     Master Card

Signature: \_\_\_\_\_  
 name as appears on card: \_\_\_\_\_  
 card no. \_\_\_\_\_ exp. date \_\_\_\_\_

Year and Model No. \_\_\_\_\_  
 Serial No. \_\_\_\_\_

Item Serial No. (if necessary): \_\_\_\_\_

Engine (include type) \_\_\_\_\_  
 Hydrostatic Pump (s) \_\_\_\_\_  
 Torque Hub \_\_\_\_\_  
 Wheel Motor \_\_\_\_\_

LF     RF     LR     RR  
 LF     RF     LR     RR

HAGIE Part No.	Qty.	Description

Check here if you want phone confirmation of parts order.

\* Orders received before 3:00 p.m., CST will be processed the same business day.  
 Regular business hours are Monday through Friday, 7:00 a.m. through 5:00 p.m..  
 \*\* If you do not have a Hagie account number, contact the Hagie Customer Support Department and you will be issued one.