



**PARTS MANUAL
FOR
HAGIE MODEL DTS 10C HI-TRACTOR
SPRAYER - DETASSELER
HAGIE MANUFACTURING COMPANY**

721 CENTRAL AVENUE WEST
BOX 273
CLARION, IOWA 50525-0273

COVERS MACHINE SERIAL NUMBERS: U1461331001 thru U1461331100

09-12 493568

07-13, 03-14, 01-18

To obtain the most current parts manual for your machine, please visit www.hagie.com.

© 2012-14, 2018 Hagie Manufacturing Company, Clarion, Iowa USA

SPRAYER IDENTIFICATION

Each Hagie sprayer is identified by means of a frame serial number. This serial number denotes the model, the year in which it was built, and the number of the sprayer. As for further identification, the engine has a serial number and the planetary hubs have identification plates that describe the type of mount and gear ratio. To insure prompt, efficient service when ordering parts or requesting service repairs from Hagie Manufacturing Company, record the serial and identification numbers in the space provided below.

NOTE: Reference to left hand and right hand used throughout this manual refers to the position when seated in the operator's seat facing forward.

SPRAYER SERIAL NUMBER

ENGINE SERIAL NUMBER

PLANETARY HUB IDENTIFICATION NUMBERS

FILTER QUICK REFERENCE

<u>QTY.</u>	<u>PART NO.</u>	<u>DESCRIPTION</u>
1	311543	ENGINE AIR FILTER, PRIMARY
1	311544	ENGINE AIR FILTER, SECONDARY
1	316372	OIL FILTER CUMM QSB
1	605602	PARKER FILTER ELEMENT, 10MICRON
1	605609	HYD FILTER ELEMENT, DONALDSON
1	657424	A/C PAPER AIR FILTER
1	657425	A/C CHARCOAL AIR FILTER

TABLE OF CONTENTS

ENGINE ASSEMBLY4-7
AIR TANK ASSEMBLY8-9
LOOP FLUSHING10-11
WHEEL MOTOR VALVES.12
VFC AND FLOW DIVIDER.13-18
RADIATOR AND OIL COOLER ASSEMBLY.19
OIL TANK ASSEMBLY20
TIRE ASSEMBLY21
LEG ASSEMBLY.22-29
STEERING CYLINDER30-31
CAB ASSEMBLY.32-36
CANTRAK ASSEMBLY.37
CONSOLE ASSEMBLY.38-40
SWITCH PANEL ASSEMBLY41
FUSE BOX AND SEAT42-43
SHEET METAL44-45
FOAM AIR REGULATOR.46
LADDER.47-48
FUEL TANK49
SERVICE PLATFORM.50
FRESH WATER TANK51
BOOM CRADLE52
BATTERY53
SOLUTION TANK54-58
SOLUTION SOLENOIDS.59-66
QUICK FILL AND FENCE ROW.67-69
REAR NOZZLE70
SOLUTION HOISING71-74
SOLUTION PUMP76
TRANSON, BOOM, AND LIFT COMPONENTS.77-90
RINSE91
FOAMER.92-93
TREAD ADJUSTMENT OPTION94-96
INJECTION PLATFORM AND FOAMER DIVERT VALVE OPTION97-98
FLOW MAX 110 MONITOR OPTION.99
WINDSHIELD WASHER.100
DETAISELER OPTION101-122
DEGALS.124-125
ELECTRICAL DIAGRAMS126-149
HYDRAULIC DIAGRAMS.150-175
ABBREVIATIONS176
INDEX177
PARTS ORDER FORM.180

ENGINE ASSEMBLY

DET. QTY PART NO. DESCRIPTION

1	8	520153	3.00 T-BOLT HOSE CLAMP (SPRNG)
2	4	311579	CAC HOSE, 3"
3	1	311577	CAC TUBE, COLD, MAI332-A
4	1	311578	CAC TUBE, HOT, MAI331-B
5	1	316867	EXHAUST STACK
6	1	470475	3" EXHAUST CLAMP
7	1	311093	RUBBER MT, 360LB LOAD 60272-2
8	1	311094	RUBBER MT, 860LB LOAD 60272-4
9	2	311095	SNUBBING WASH FOR 311093/094
10	1	316863	LH FRT ENG MT, MFM66-A
11	1	316865	LH REAR ENG MT, MRM103-A
12	1	316337	LH HYD TUBE MT, 2100 98
13	1	316338	REAR HYD TUBE MT, 2100 98
14	1	470274	TUBE CLAMP BODY, .750-.750
15	1	470275	TUBE CLAMP BODY, 1.000-1.000
16	2	470278	CLAMP WELD PLATE, SNGL, 2.75LG
17	1	473784	12MM LOCK WASHER
18	1	473818	10MM-1.50 X 40MM HEX BOLT GR8
19	1	900086	5/16UNC X 2 1/4 HEX BOLT
20	2	920501	5/16 LOCK WASHER
21	1	900069	5/16UNC X 2" HEX BOLT
22	1	473798	10MM LOCK WASHER
23	1	473782	12MM-1.75 X 18MM HEX BOLT GR8
24	1	316683	FUEL FILTER, ENG, TIER 3 07
25	1	316684	FILTER,PRE FUEL 25 MICRON
26	1	800511	PUMP DRIVE ASSY
27	1	800512	DRIVE PLATE

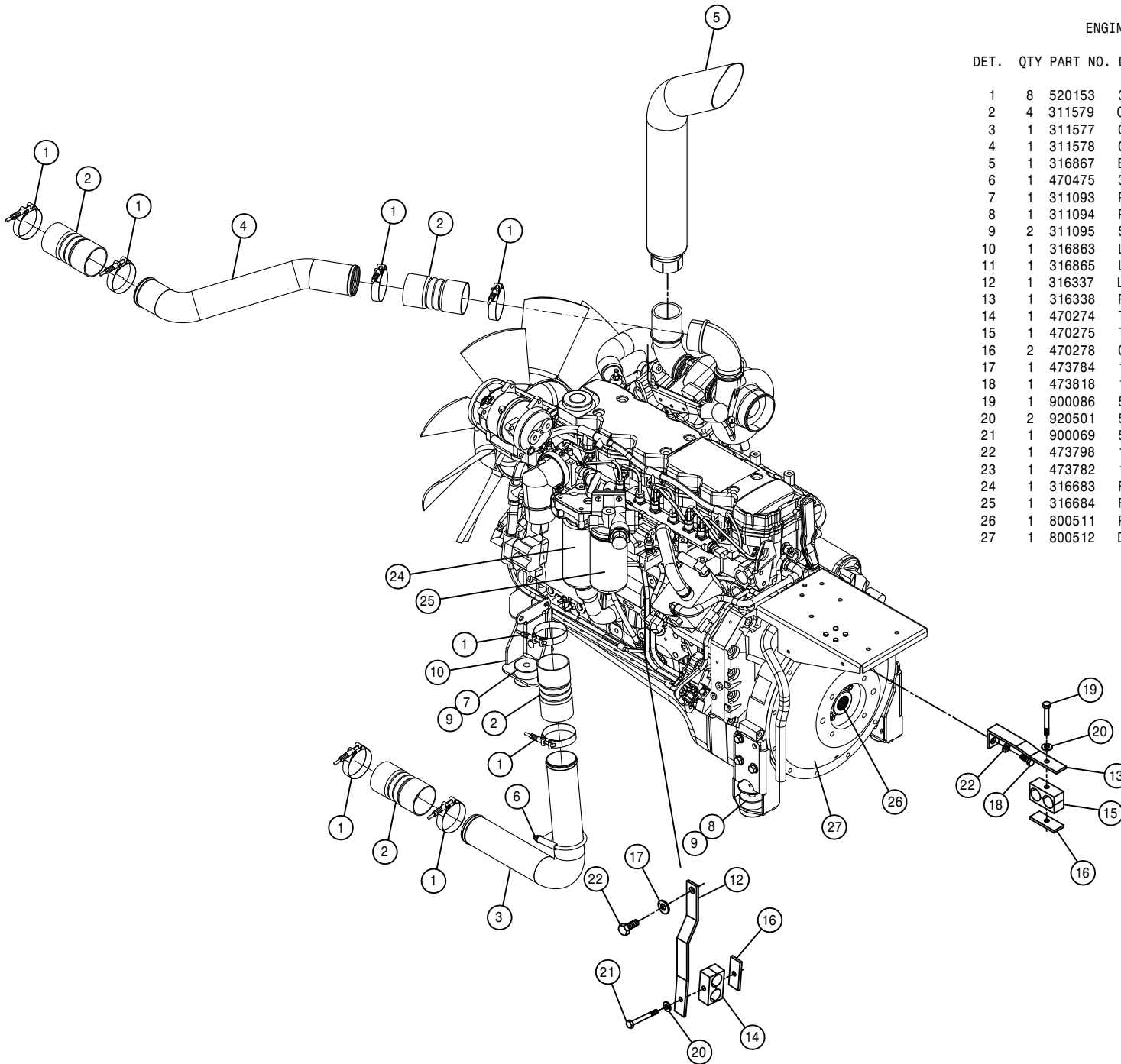

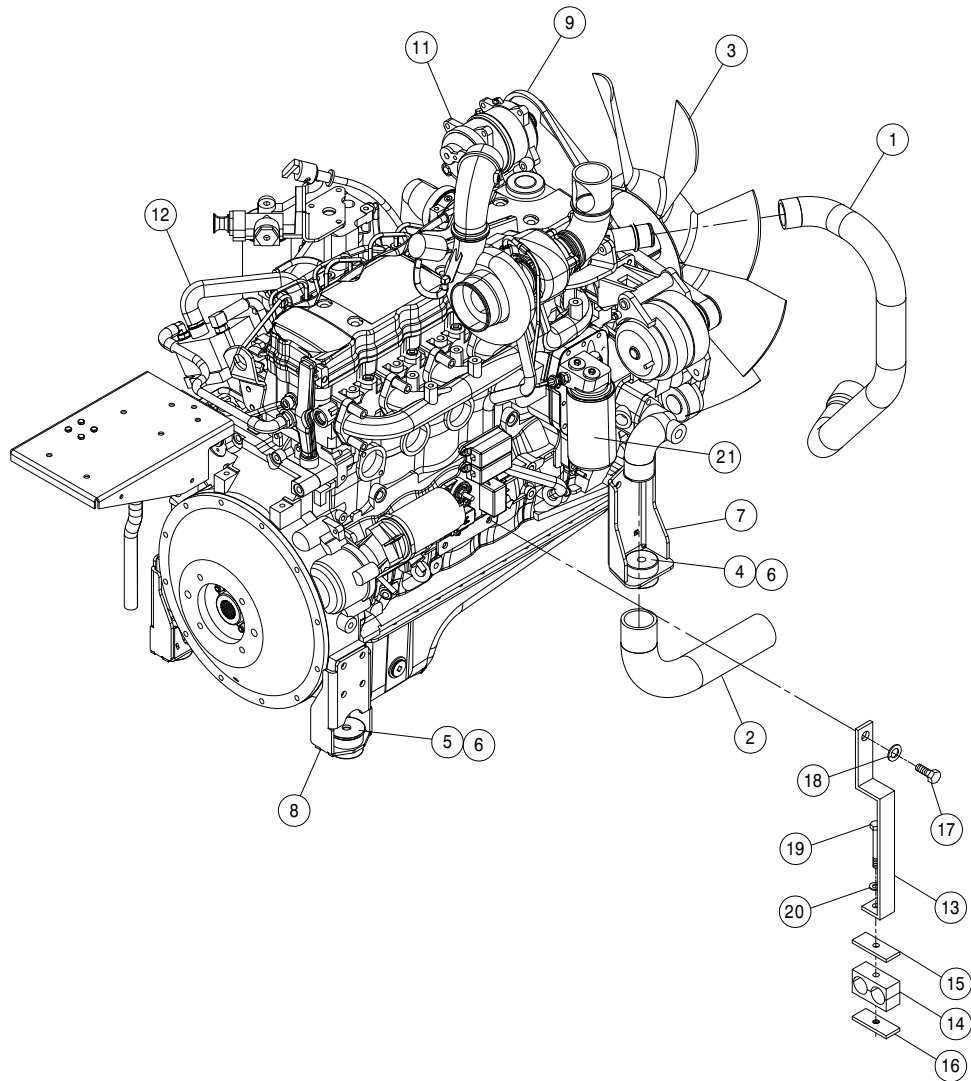

ENGINE ASSEMBLY

DET.	QTY	PART NO.	DESCRIPTION
1	1	311096	UPPER RED HOSE, MCA188-A
2	1	311097	LOWER RAD HOSE, MCA189-B
3	1	316866	27" FAN
4	1	311093	RUBBER MT, 360LB LOAD 60272-2
5	1	311094	RUBBER MT, 860LB LOAD 60272-4
6	2	311095	SNUBBING WASH FOR 311093/094
7	1	316862	RH FRT ENG MT, MFM67-A
8	1	316864	RH REAR ENG MT, MRM104-A
9	1	316851	BELT, GATES GREEN STRIPE 9447
10	1	316391	DELCO ALTERNATOR, 130 AMP 24SI
11	1	657403	A/C COMPSR, 180D PORTS TM15/12
12	1	316840	CUMMINS ENG, QSB6.7 T3 215HP 10
13	1	316336	RH HYD TUBE MT, 2100 98
14	1	470274	TUBE CLAMP BODY, .750-.750
15	1	470276	CLAMP COVER PLATE, SNGL, 2.55LG
16	1	470278	CLAMP WELD PLATE, SNGL, 2.75LG
17	1	473783	12MM-1.75 X 25MM HEX BOLT
18	1	473784	12MM LOCK WASHER
19	1	900086	5/16UNC X 2 1/4 HEX BOLT
20	1	920501	5/16 LOCK WASHER
21	1	316372	LUBE FILTER (CUMM ENG 316360)

AIR CLEANER ASSEMBLY

DET. QTY PART NO. DESCRIPTION

DET.	QTY	PART NO.	DESCRIPTION
1	1	311580	5"-4" HUMP HOSE
2	1	311581	7"-5" 90DEG REDU ELBOW,RUBBER
3	1	311582	7.00-6.00 ID REDUCER BUSHING
4	1	311576	CAC TUBE MAI330-A
5	1	311520	ENGINE PRE CLEANER
6	1	311541	AIR CLEANER,OPTIAIR 1300
7	2	311542	AIR CLEANER MT BAND FOR 311541
8	3	520150	7.38/7.69 T-BOLT HOSE CLAMP SS
9	2	520148	5.38/5.69 T-BOLT HOSE CLAMP SS
10	1	520134	4.31/4.59 T-BOLT HOSE CLAMP SS
11	1	311543	PRIMARY AIR FILTER FOR 311541
12	1	311544	SECONDARY FILTER FOR 311541
13	1	311565	COVER ASSEMBLY FOR 311541

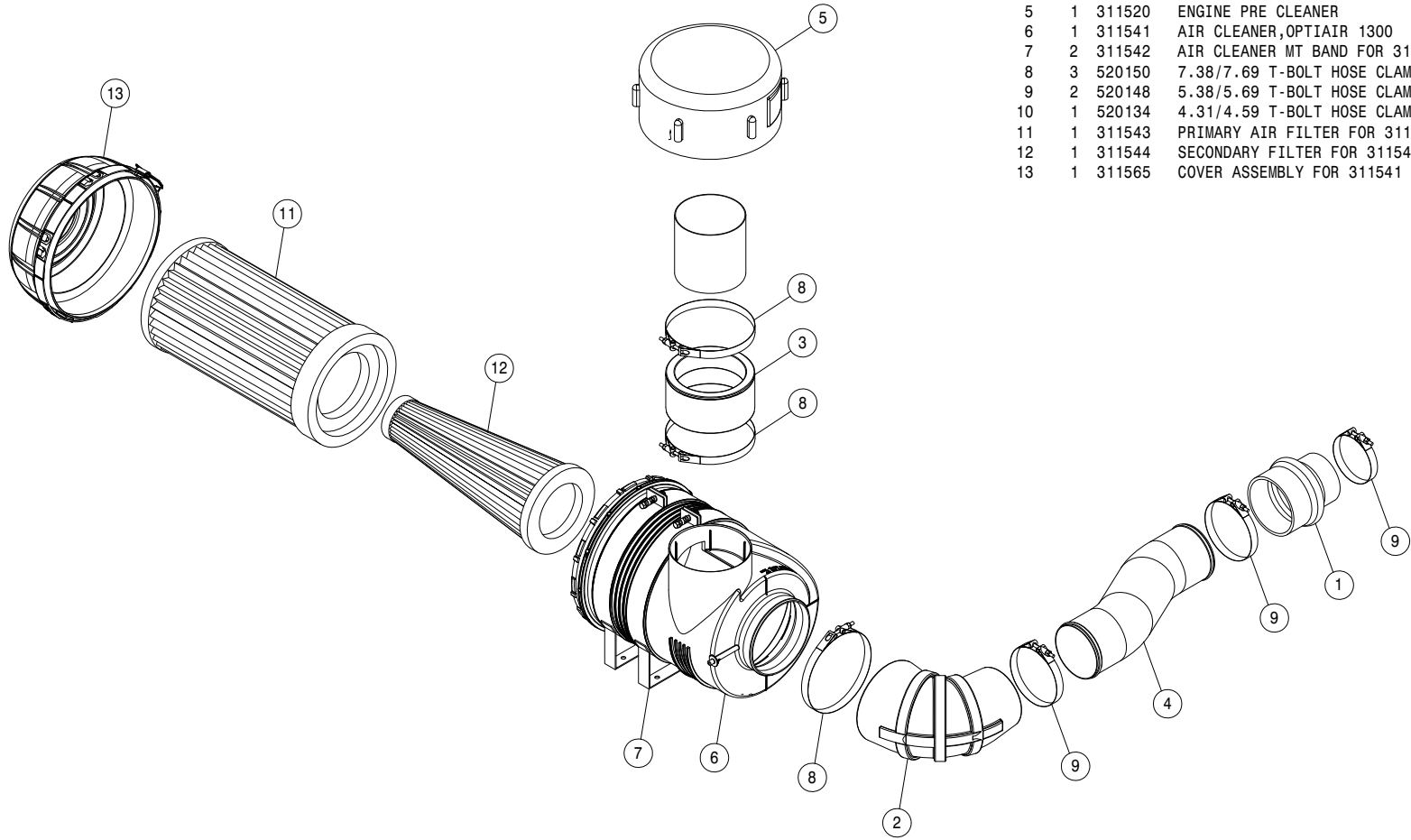

HYDROSTATIC PUMP ASSEMBLY

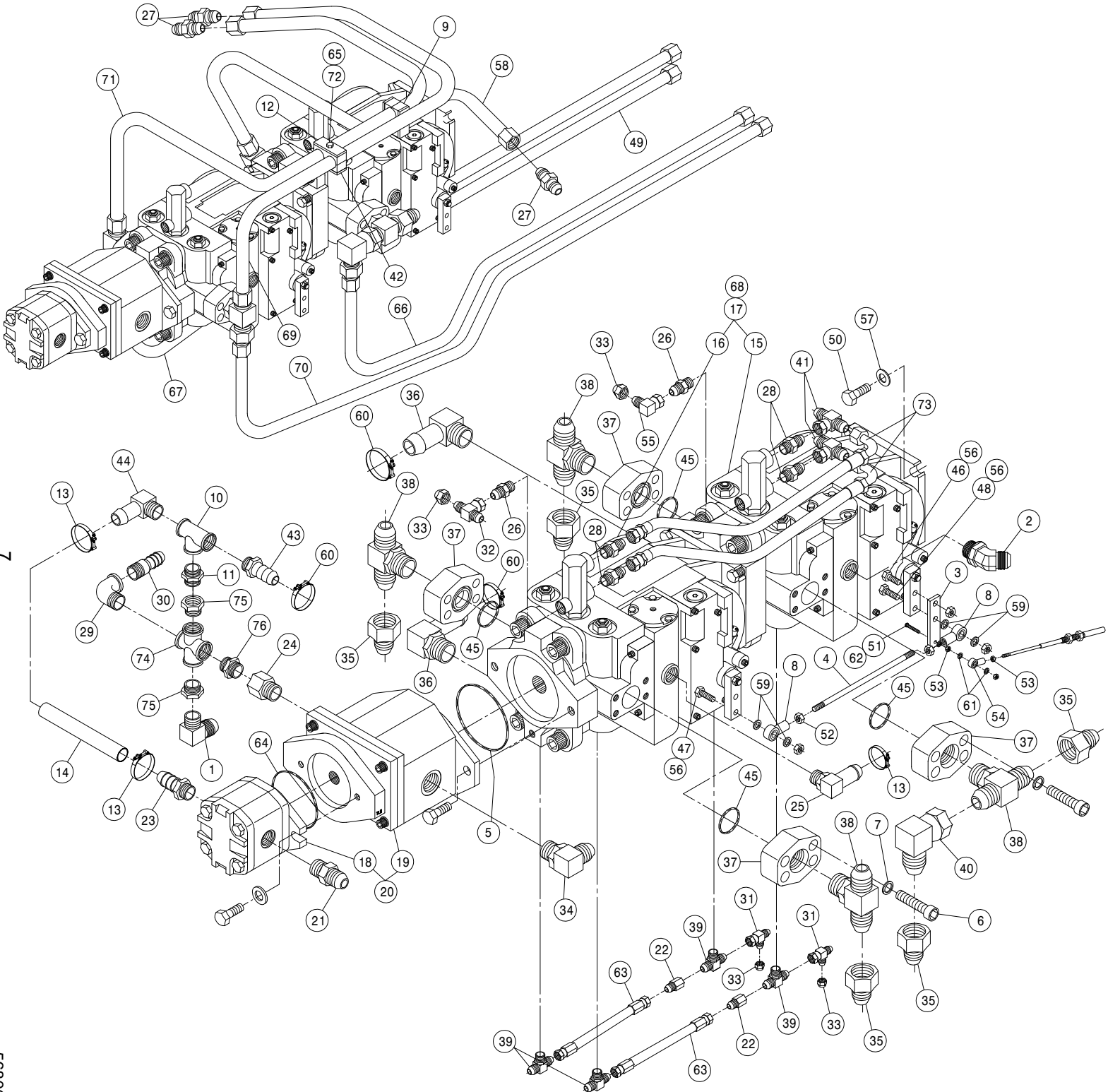

DET.	QTY	PART NO.	DESCRIPTION
1	1	618519	1 1/16MJIC-90-1MNPT LBO
2	1	618313	1 1/16MJIC-45-1 1/16MOR LBO
3	1	316160	PUMP CONT LEVER EXT 280 CUMM
4	1	316335	HYDST PUMP CTRL ROD, 2100 98
5	1	606357	O-RING, 3.737ID-.103CS-3.94 BMT
6	16	470188	7/16-14 X 1 3/4 SKTHD CAP SCR
7	16	470189	7/16 HC LOCK WASH FOR 618598
8	2	473998	BALL JOINT, 1/4-28 1/4BORE
9	2	470275	TUBE CLAMP BODY, 1.000-1.000
10	1	505101	BLK PIPE TEE 1.00NPT
11	1	505105	1MNPT HEX PIPE NIPPLE STL
12	2	470276	CLAMP COVER PLATE, SNGL, 2.55LG
13	3	520137	1.12/1.25 T-BOLT HOSE CLAMP
14	1	601399	HOSE, 3/4 X 13 1FBR-1SPI
15	1	606231	SUND 75CC PUMP, C/C MT (.022)
16	1	606234	SUND 75CC PUMP, C/B MT (.022)
17	1	606230	TANDEM PUMP, 606231/606234 .022
18	1	606929	SUND GEAR PUMP .66CI, SPLINED
19	1	606353	GEAR PUMP, 5.38CI SAUER
20	1	606352	TANDEM PUMP, 606353 & 606929
21	1	611126	7/8MJIC-7/8MOR ADPTR
22	2	618734	9/16JIC .047 ORIFICE ADPTR
23	1	618075	3/4 HOSE BARB-1 1/16MOR
24	1	618816	1 7/8MOR-1 1/4FNPT ADPTR
25	1	618118	3/4 HOSE BARB-90-1 1/16MOR
26	2	618126	9/16MJIC-9/16MOR ADPTR
27	3	618577	1 5/16MJIC UNION
28	4	618327	3/4MJIC-7/8MOR ADPTR
29	1	506410	BLK PIPE ST EL 90DEG 1.25NPT
30	1	715660	HOSE BARB 1 1/4NPT X 1 1/4
31	2	618486	9/16FJIC SW RUN TEE-9/16MJIC
32	1	618514	9/16FJ SW BRANCH TEE-9/16MJ
33	4	618531	9/16FJIC CAP NUT
34	1	618477	1 5/8MJIC-90-1 5/8MOR LBO
35	5	618541	1 5/16FJIC-1 1/16MJIC ADPTR
36	2	618564	1IN HOSE BARB-90-1 5/16MOR
37	4	618598	1" 4-BOLT FLG X 1 5/16 FOR
38	4	618599	1 5/16MOR BRANCH TEE-1 5/16MJ
39	4	618629	9/16MOR BRANCH TEE-9/16MJIC
40	1	618640	1 5/16MJ-90-1 5/16FJ SWIV LBO
41	2	618643	3/4FJ SW BRANCH TEE-3/4MJ
42	2	470278	CLAMP WELD PLATE, SNGL, 2.75LG
43	1	714560	1NPT X 1 HOSE BARB
44	1	716000	3/4 HOSE BARB-90-1MNPT
45	4	870219	BUNA ORING 1 5/16 X 1 9/16 90D
46	1	900003	1/4UNC X 1" HEX BOLT
47	1	900004	1/4UNC X 1 1/4 HEX BOLT
48	1	900005	1/4UNC X 1 1/2 HEX BOLT
49	1	615719	LH FRT PUMP LWR TUBEASSY210098
50	4	900265	1/2UNC X 1 1/2 HEX BOLT
51	1	903893	10-32 X 1" PHIL PAN MACH SCR
52	2	910001	1/4UNF HEX NUT
53	2	910027	10-32 HEX NUT
54	1	473921	BALL JOINT NO 10-32 THD
55	1	618618	9/16MJIC-90-9/16FJIC SWIV LBO
56	3	914000	1/4UNC HEX STOVER NUT
57	4	920004	1/2 SAE FLAT WASHER
58	1	615718	LH FRT PUMP UPR TUBEASSY210098
59	4	920500	1/4 LOCK WASHER
60	3	520138	1.38/1.56 T-BOLT HOSE CLAMP
61	3	920510	#10 LOCK WASHER
62	1	914027	10-32 HEX STOVER NUT
63	2	616252	04-381-06FJX-06FJX-13 H/A
64	1	606924	O-RING FOR SUND A-MT
65	2	920501	5/16 LOCK WASHER
66	1	615717	RH FRT PUMP LWR TUBEASSY210098
67	1	615723	LH REAR PUMP LWR TUBE ASSY 98
68	1	606950	O-RING, 4.739ID-.07CS-4.879 CMT
69	1	615720	RH REAR PUMP UPR TUBE ASSY 98
70	1	615721	RH REAR PUMP LWR TUBE ASSY 98
71	1	615722	LH REAR PUMP UPR TUBE ASSY 98
72	2	900086	5/16UNC X 2 1/4 HEX BOLT
73	2	614739	08-482TC-08FJX-08FJX90-16 H/A
74	1	506202	BLK PIPE CROSS 1.25NPT
75	2	506005	1 1/4 TO 1 RED BUSH BLK MAL
76	1	507026	1 1/4MNPT HEX PIPE NIPPLE STL

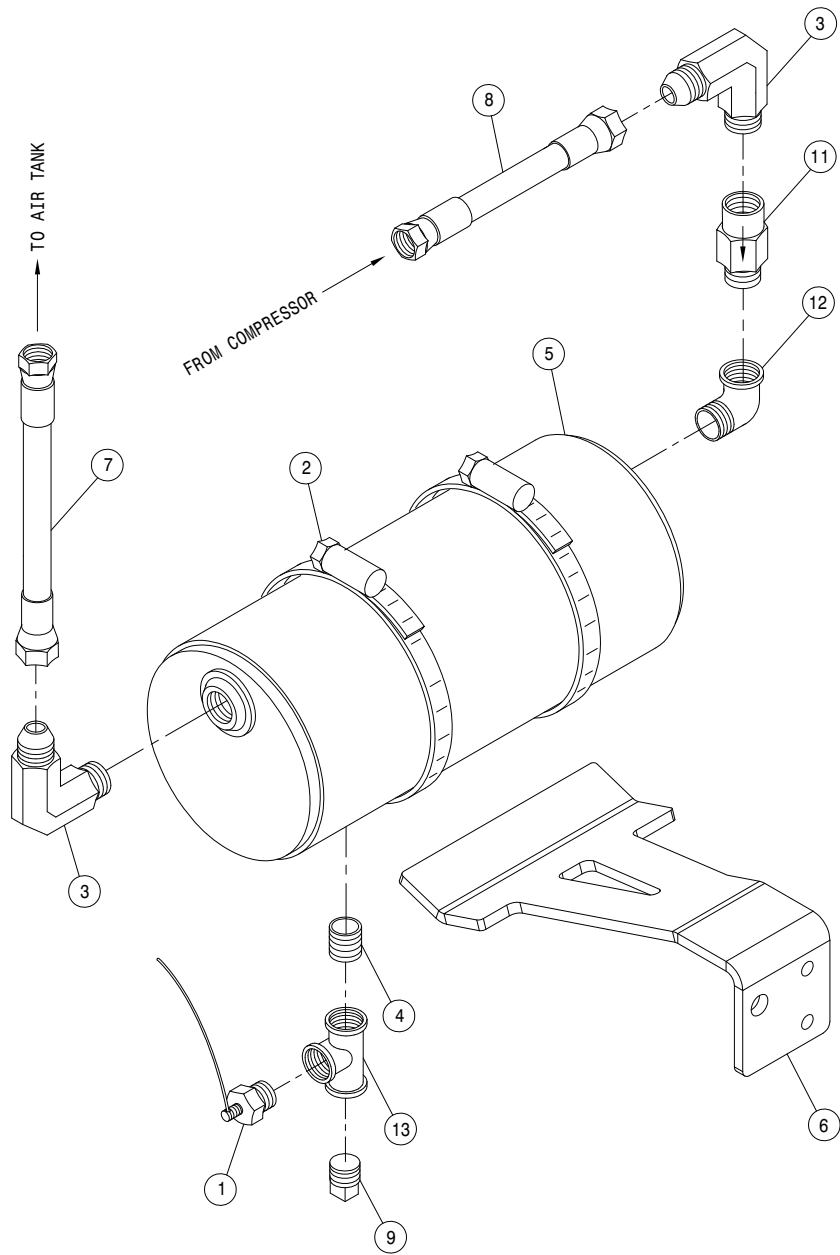

AIR WET TANK ASSEMBLY

DET. QTY PART NO. DESCRIPTION

1	1	470266	DRAIN VALVE KIT, 1/4NPT	
2	2	520086	HOSE CLAMP NO 88 STAINLESS	
3	2	611145	3/4MJIC-90-1/2MNPT LBO	
4	1	501601	CLOSE NIPPLE .25NPT	
5	1	701115	WET TANK WLD	98
6	1	316844	WET TANK MT BRKT, DTS10	'10
7	1	615624	06-482TC-08FJX-08FJX-28	H/A
8	1	611304	08P919-08FJX-10FJX-16	H/A
9	1	501102	1/4 PIPE PLUG	
10	1	501101	BLK PIPE TEE .25NPT	
11	1	711032	CHECK VALVE, 1/2"FNPT-1/2"MNPT	
12	1	503400	BLK PIPE ST EL 90DEG .50NPT	

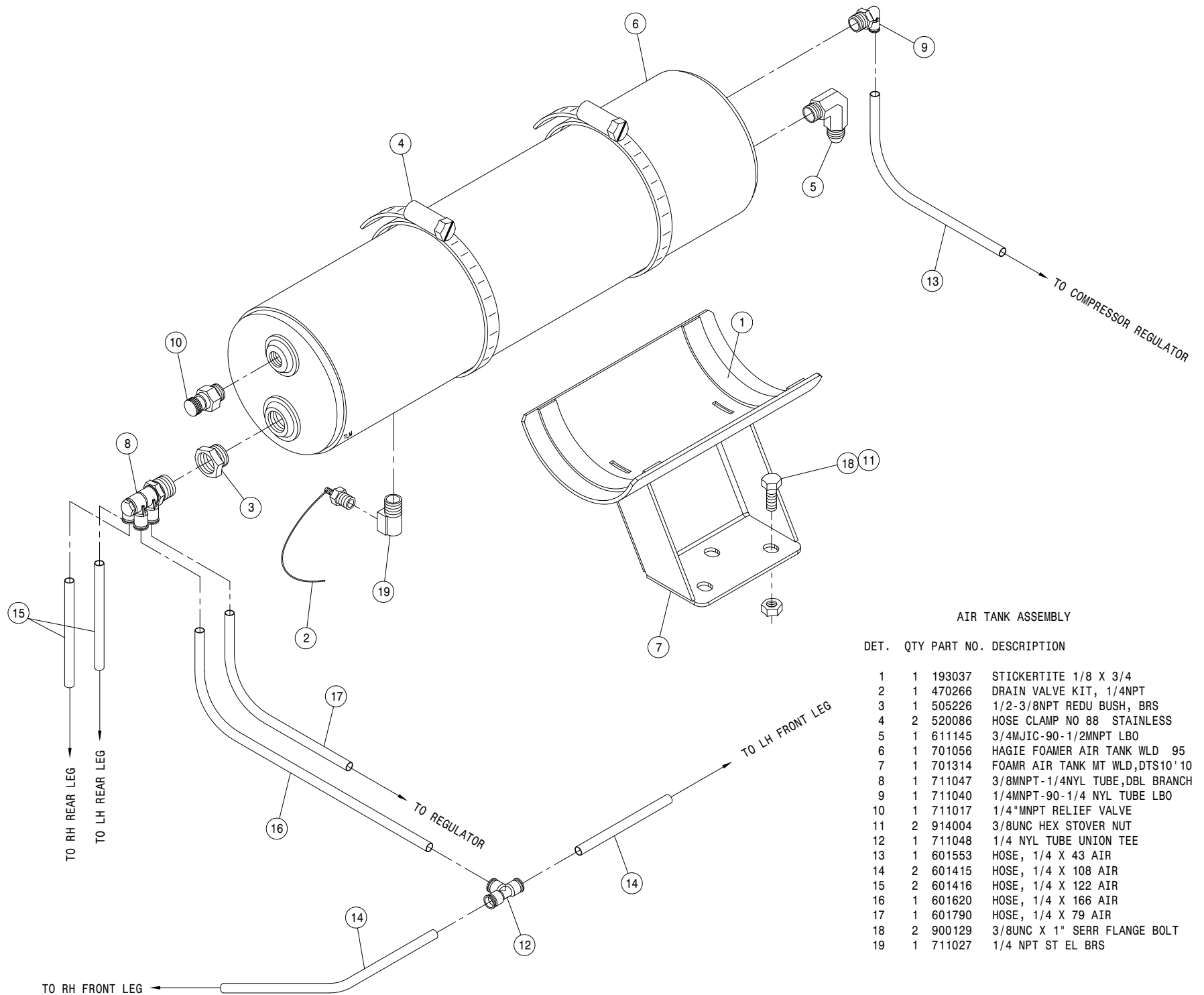

FRONT

REAR

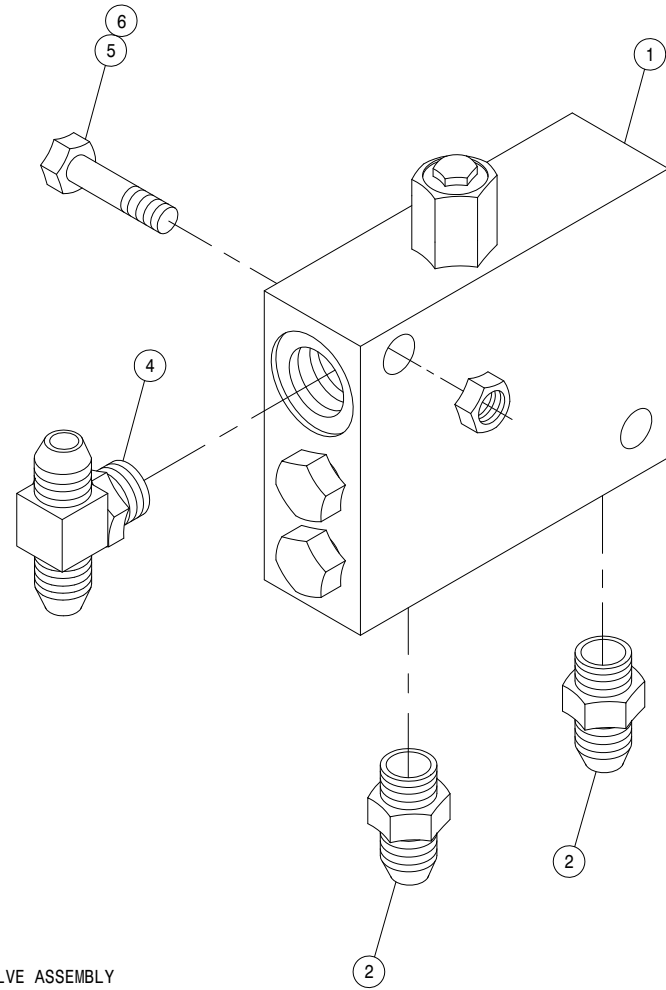
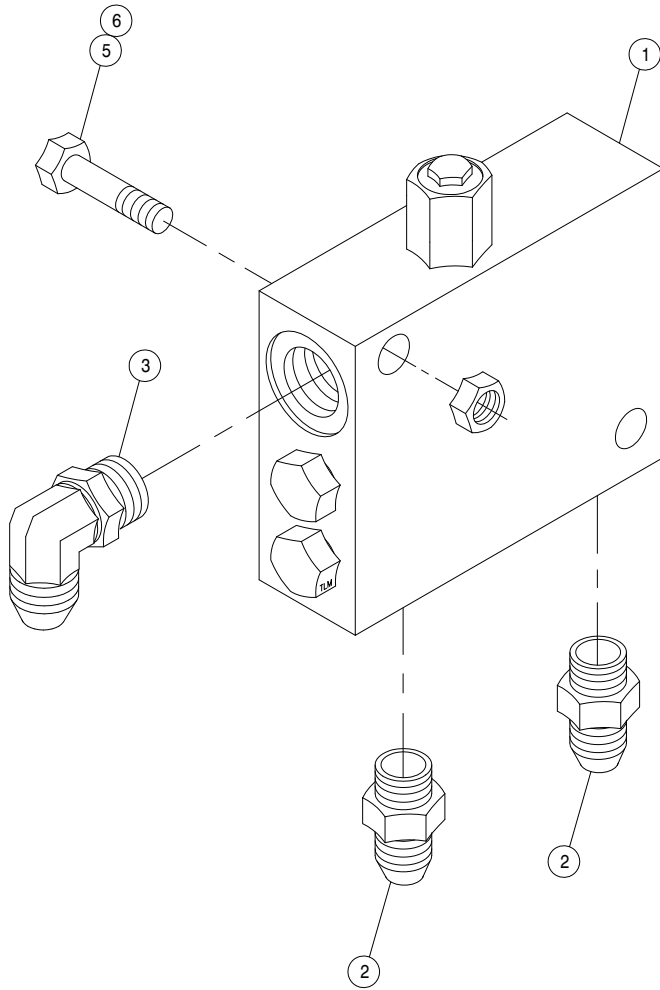

LOOP FLUSHING VALVE ASSEMBLY

DET. QTY PART NO. DESCRIPTION

1	2	610580	REMOTE FLUSHING VALVE, SUND
2	4	618126	9/16MJIC-9/16MOR ADPTR
3	1	618119	9/16MJIC-90-9/16MOR LBO
4	1	618629	9/16MOR BRANCH TEE-9/16MJIC
5	4	900133	3/8UNC X 2" SERR FLANGE BOLT
6	4	914004	3/8UNC HEX STOVER NUT

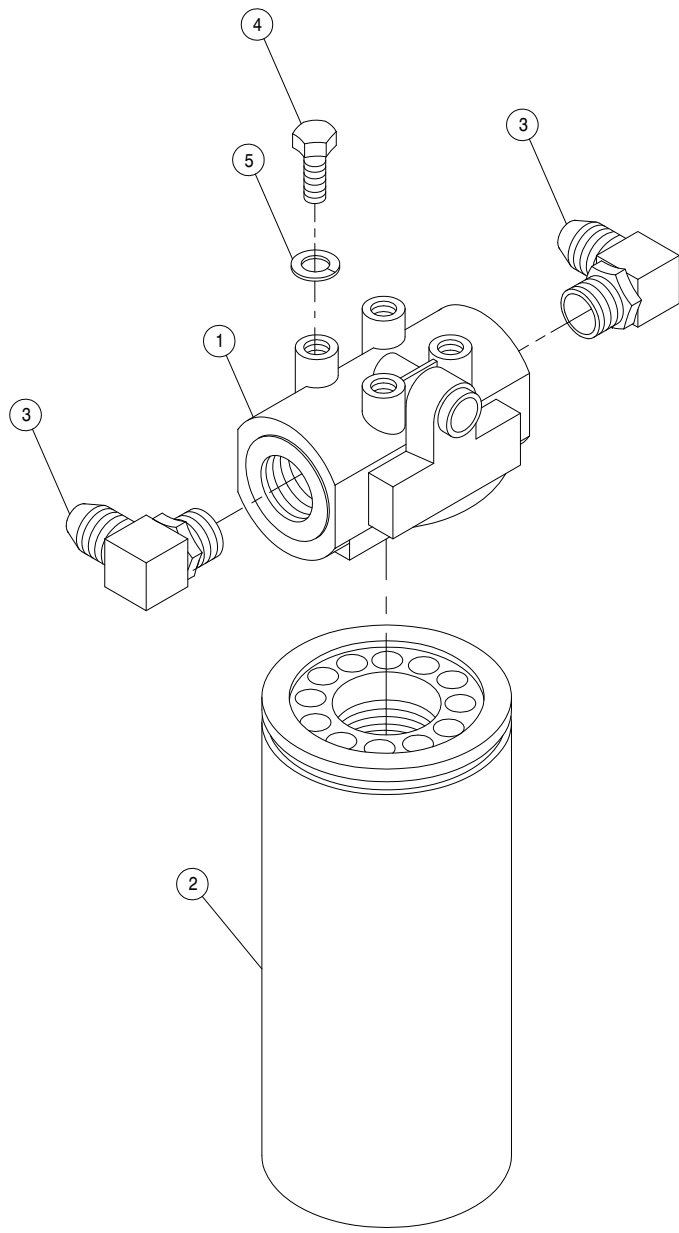

HI-PRESS FILTER ASSEMBLY

DET. QTY PART NO. DESCRIPTION

1	1	605608	HYD FILTER HEAD, DONALDSON
2	1	605609	HYD FILTER ELEMENT, DONALDSON
3	2	618474	3/4MJIC-90-1 1/16MOR LBO
4	4	900128	3/8UNC X 3/4 HEX BOLT
5	4	920502	3/8 LOCK WASHER

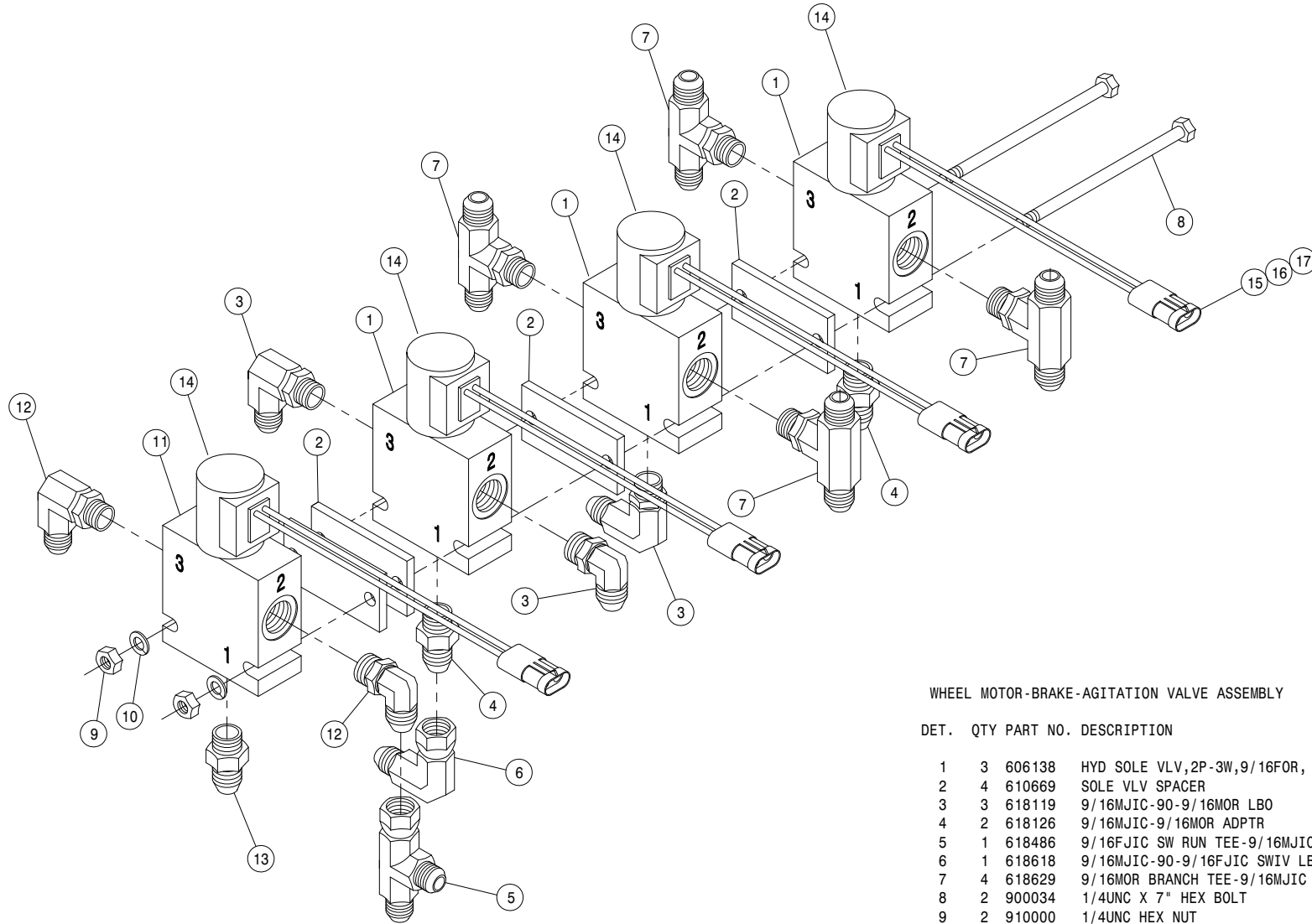

WHEEL MOTOR-BRAKE-AGITATION VALVE ASSEMBLY

DET.	QTY	PART NO.	DESCRIPTION
1	3	606138	HYD SOLE VLV,2P-3W,9/16FOR, WP
2	4	610669	SOLE VLV SPACER
3	3	618119	9/16MJIC-90-9/16MOR LBO
4	2	618126	9/16MJIC-9/16MOR ADPTR
5	1	618486	9/16FJIC SW RUN TEE-9/16MJIC
6	1	618618	9/16MJIC-90-9/16FJIC SWIV LBO
7	4	618629	9/16MOR BRANCH TEE-9/16MJIC
8	2	900034	1/4UNC X 7" HEX BOLT
9	2	910000	1/4UNC HEX NUT
10	2	920500	1/4 LOCK WASHER
11	1	606139	HYD SOLE VLV,2P3W,3/4FOR, WP
12	2	618115	9/16MJIC-90-3/4MOR LBO
13	1	618109	9/16MJIC-3/4MOR ADPTR
14	4	610016	COIL FOR HYD VLV 610318
15	4	291664	PED,RECP,WP,2W
16	8	291675	PED,TERM,M,WP,16-14GA
17	8	291620	PED,SEAL,GREEN,18-16GA

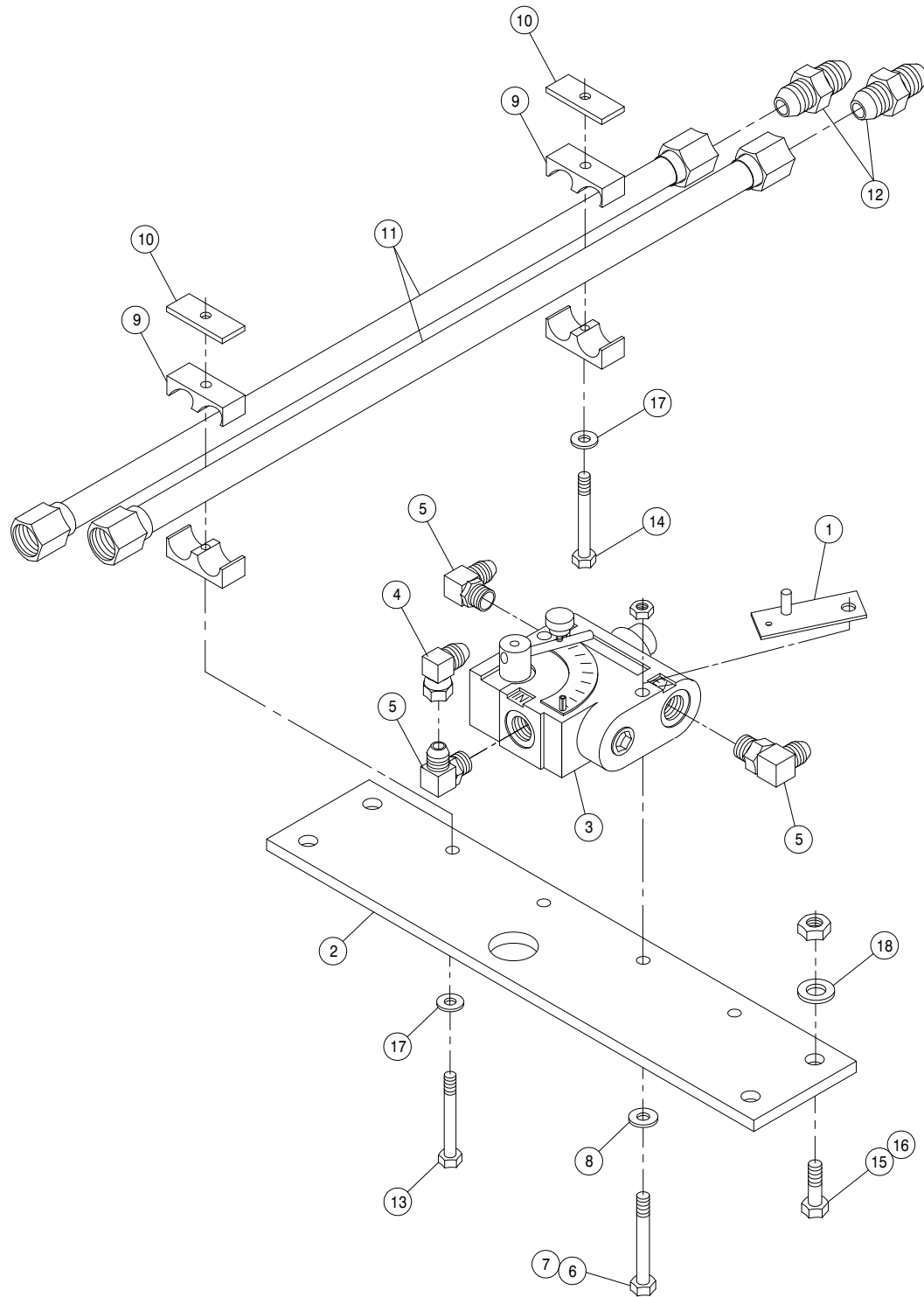

SOLUTION PUMP VARIABLE FLOW CONTROL ASSEMBLY

DET. QTY PART NO. DESCRIPTION

1	1	342306	SOLU PUMP VFC STOP WLD,9G 96
2	1	361477	TIE PLT, 2100 98
3	1	606818	FLO CONT FCR51 0-16GPM 7/8FOR
4	1	618301	7/8MJIC-90-7/8FJIC SWIV LBO
5	3	611128	7/8MJIC-90-7/8MOR LBO
6	2	900009	1/4UNC X 2 3/4 HEX BOLT
7	2	914000	1/4UNC HEX STOVER NUT
8	2	920000	1/4 SAE FLAT WASHER
9	4	470274	TUBE CLAMP BODY, .750-.750
10	4	470278	CLAMP WELD PLATE, SNGL, 2.75LG
11	4	615724	FRT MAIN HYD TUBE ASSY,2100 98
12	4	618177	1 1/16MJIC UNION
13	2	900069	5/16UNC X 2" HEX BOLT
14	2	900086	5/16UNC X 2 1/4 HEX BOLT
15	4	900265	1/2UNC X 1 1/2 HEX BOLT
16	4	914008	1/2UNC HEX STOVER NUT
17	4	920001	5/16 SAE FLAT WASHER
18	4	920004	1/2 SAE FLAT WASHER

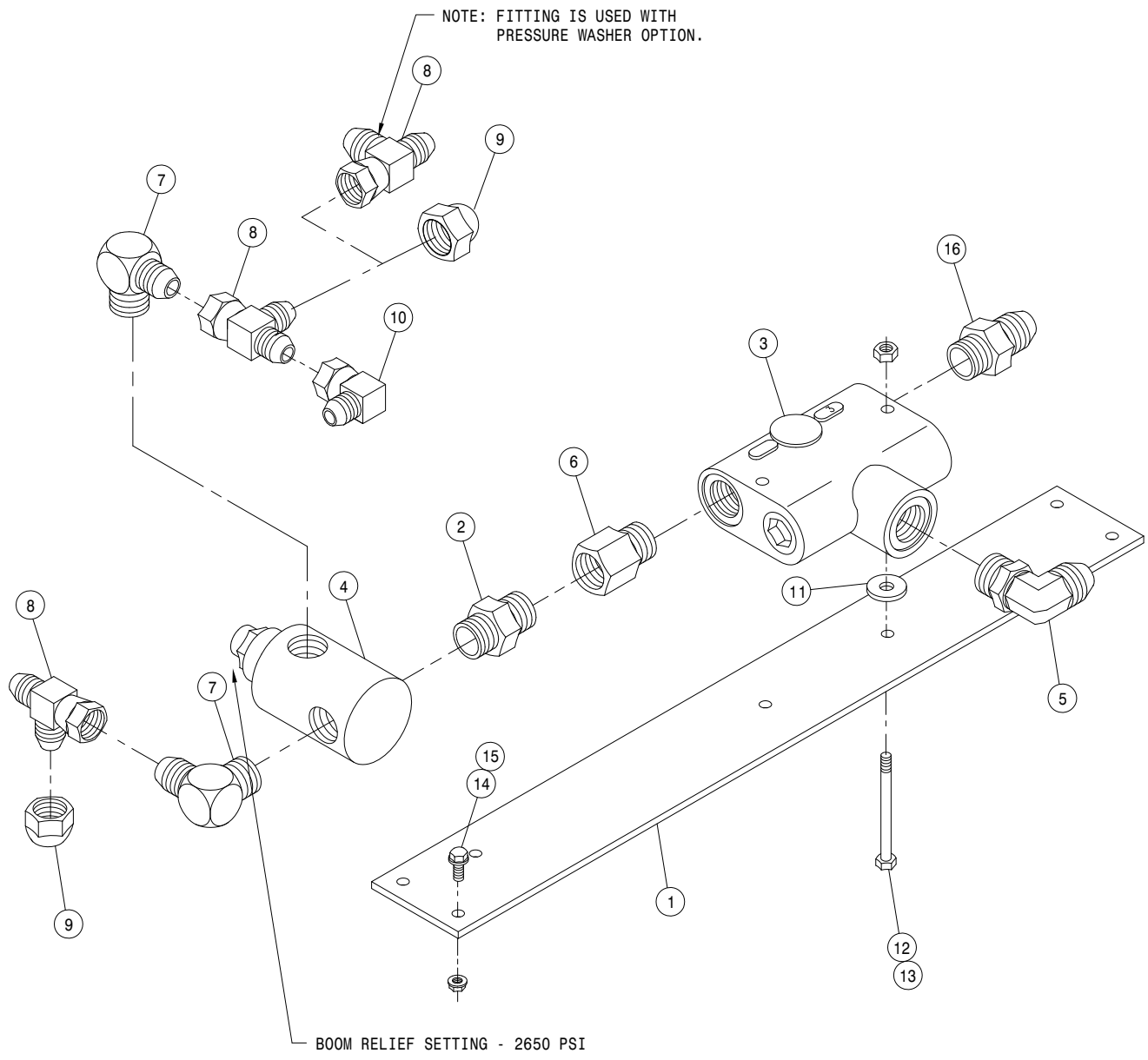

FLOW DIVIDER ASSEMBLY

DET.	QTY	PART NO.	DESCRIPTION
1	1	361478	REAR FLOW DIV PLT, 2100 98
2	1	500000	1/2MNPT HEX PIPE NIPPLE STL
3	1	610307	FLO DIV BG53 3GPM PRI 7/8FOR
4	1	607512	RELIEF VALVE, RL50, 1850 PSI
5	1	611128	7/8MJIC-90-7/8MOR LBO
6	1	618072	7/8MOR-1/2FNPT ADPTR
7	2	618107	9/16MJIC-90-1/2MNPT LBO
8	3	618486	9/16FJIC SW RUN TEE-9/16MJIC
9	2	618531	9/16FJIC CAP NUT
10	1	618618	9/16MJIC-90-9/16FJIC SWIV LBO
11	2	748500	RUBER WASH 3/8X1/4IDX1 1/2 OD
12	2	900009	1/4UNC X 2 3/4 HEX BOLT
13	2	914000	1/4UNC HEX STOVER NUT
14	4	470118	1/4UNC X 3/4 FLANGE HEX BOLT
15	4	470121	1/4UNC HEX FLANGE LOCK NUT
16	1	618310	9/16MJIC-7/8MOR ADPTR

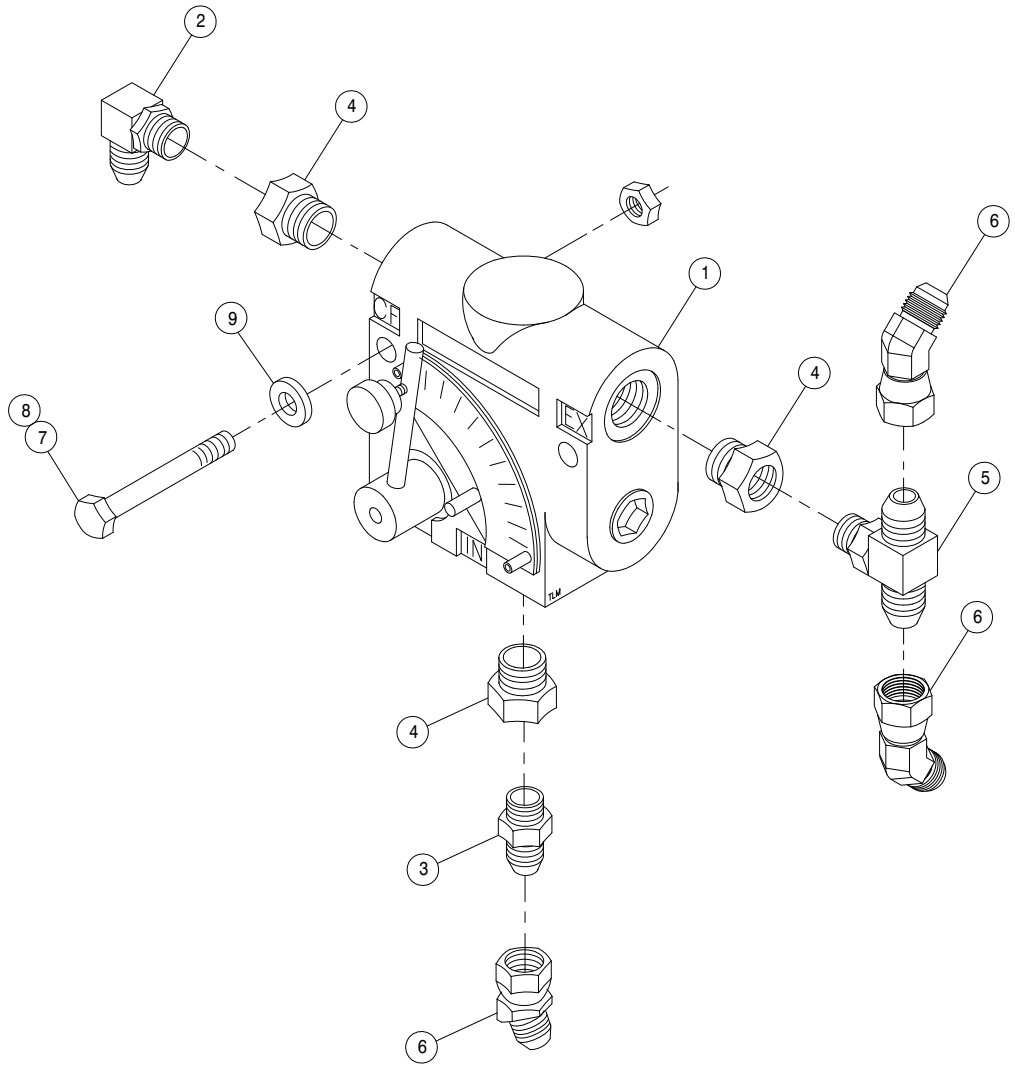

AGITATOR VARIABLE FLOW CONTROL ASSEMBLY

DET.	QTY	PART NO.	DESCRIPTION
1	1	606827	FLO CONT FC51 0-3 VARI 7/8FOR
2	1	618119	9/16MJIC-90-9/16MOR LBO
3	1	618126	9/16MJIC-9/16MOR ADPTR
4	3	618172	7/8MOR-9/16FOR ADPTR
5	1	618629	9/16MOR BRANCH TEE-9/16MJIC
6	6	618634	9/16MJIC-45-9/16FJIC SWIV LBO
7	2	900008	1/4UNC X 2 1/2 HEX BOLT
8	2	914000	1/4UNC HEX STOVER NUT
9	2	470212	1/4 BONDED SEALING WASH, SS

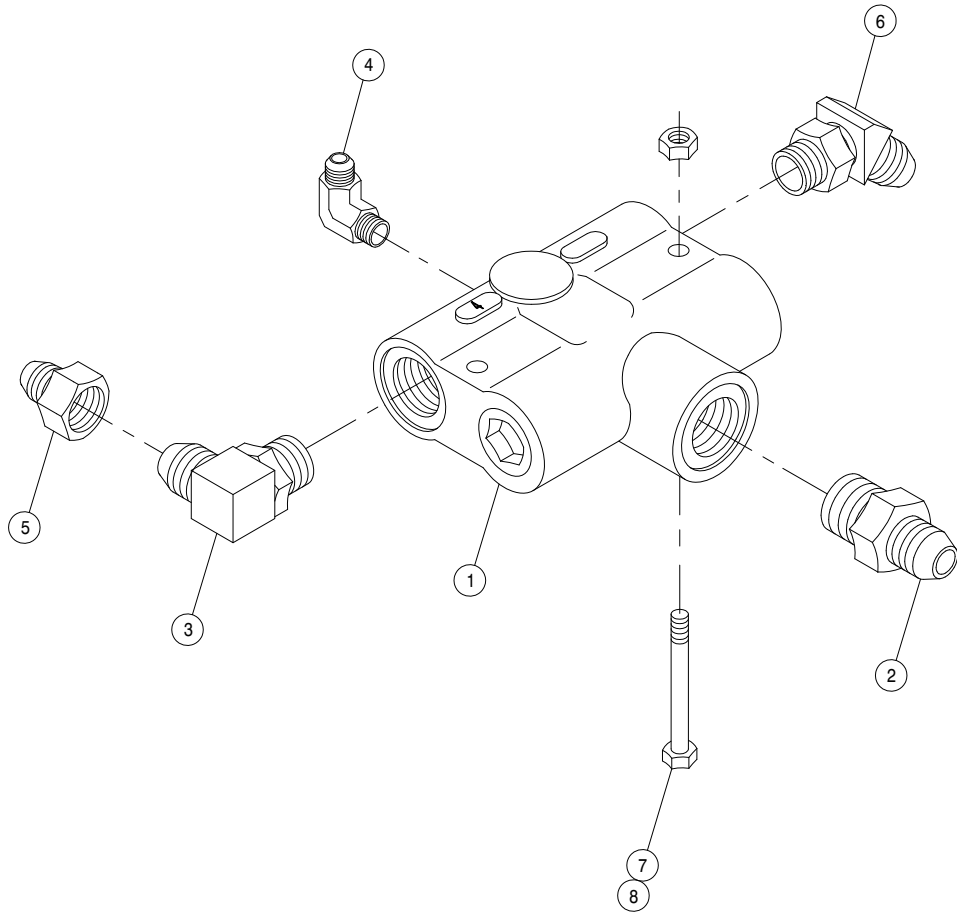

BGR56 FLOW DIVIDER ASSEMBLY

DET. QTY PART NO. DESCRIPTION

1	1	607528	FLO DIV BGR54 4GPM PRI 7/8FOR
2	1	611126	7/8MJIC-7/8MOR ADPTR
3	1	611128	7/8MJIC-90-7/8MOR LBO
4	1	618015	9/16MJIC-90-3/8MNPT LBO
5	1	618557	7/8FJIC-9/16MJIC ADPTR
6	1	618644	7/8MJIC-45-7/8MOR LBO
7	2	900008	1/4UNC X 2 1/2 HEX BOLT
8	2	914000	1/4UNC HEX STOVER NUT

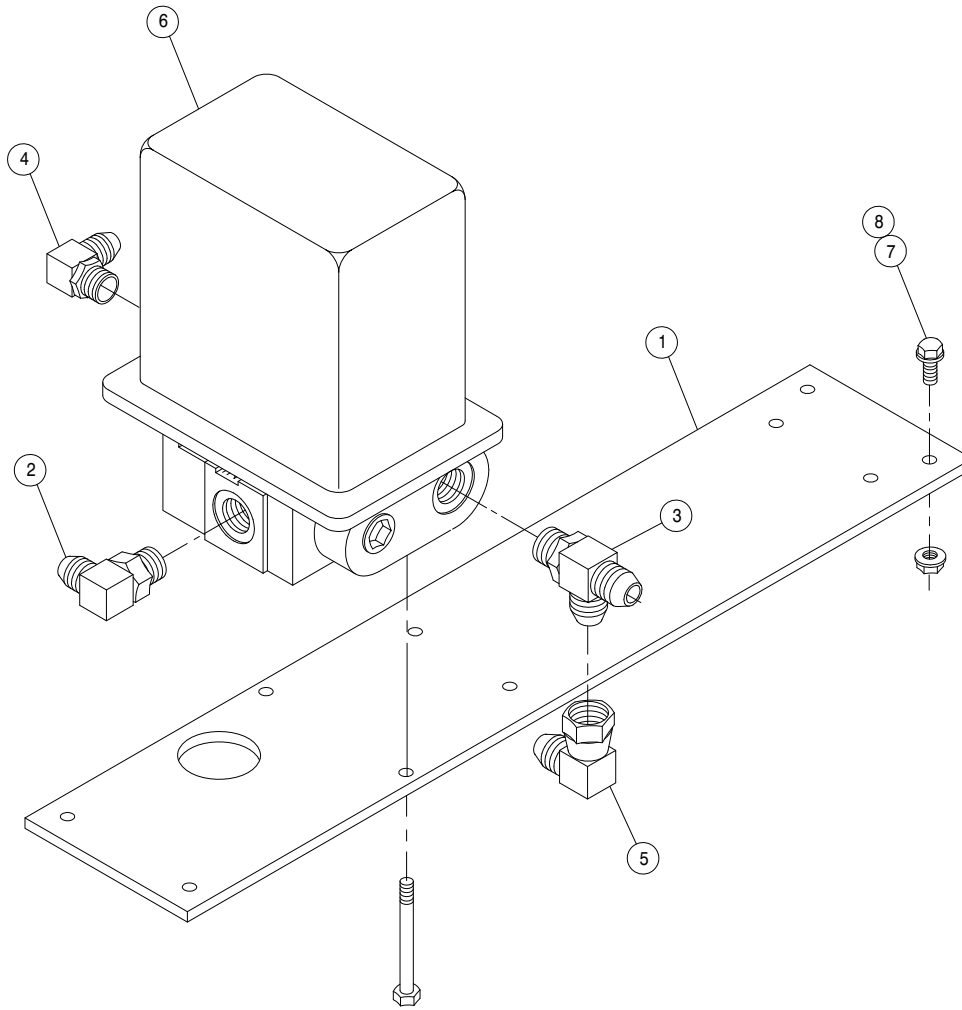

RAVEN HYDRAULIC CONTROL VALVE ASSEMBLY

DET. QTY PART NO. DESCRIPTION

1	1	361476	ELECT VLV MTG PLT, 2100	98
2	1	611128	7/8MJIC-90-7/8MOR LBO	
3	1	618130	7/8MOR RUN TEE-7/8MJIC	
4	1	618183	3/4MJIC-90-7/8MOR LBO	
5	1	618301	7/8MJIC-90-7/8FJIC SWIV LBO	
6	1	690621	VALVE HYD CTRL, 16GPM RAVEN	
7	4	470118	1/4UNC X 3/4 FLANGE HEX BOLT	
8	4	470121	1/4UNC HEX FLANGE LOCK NUT	

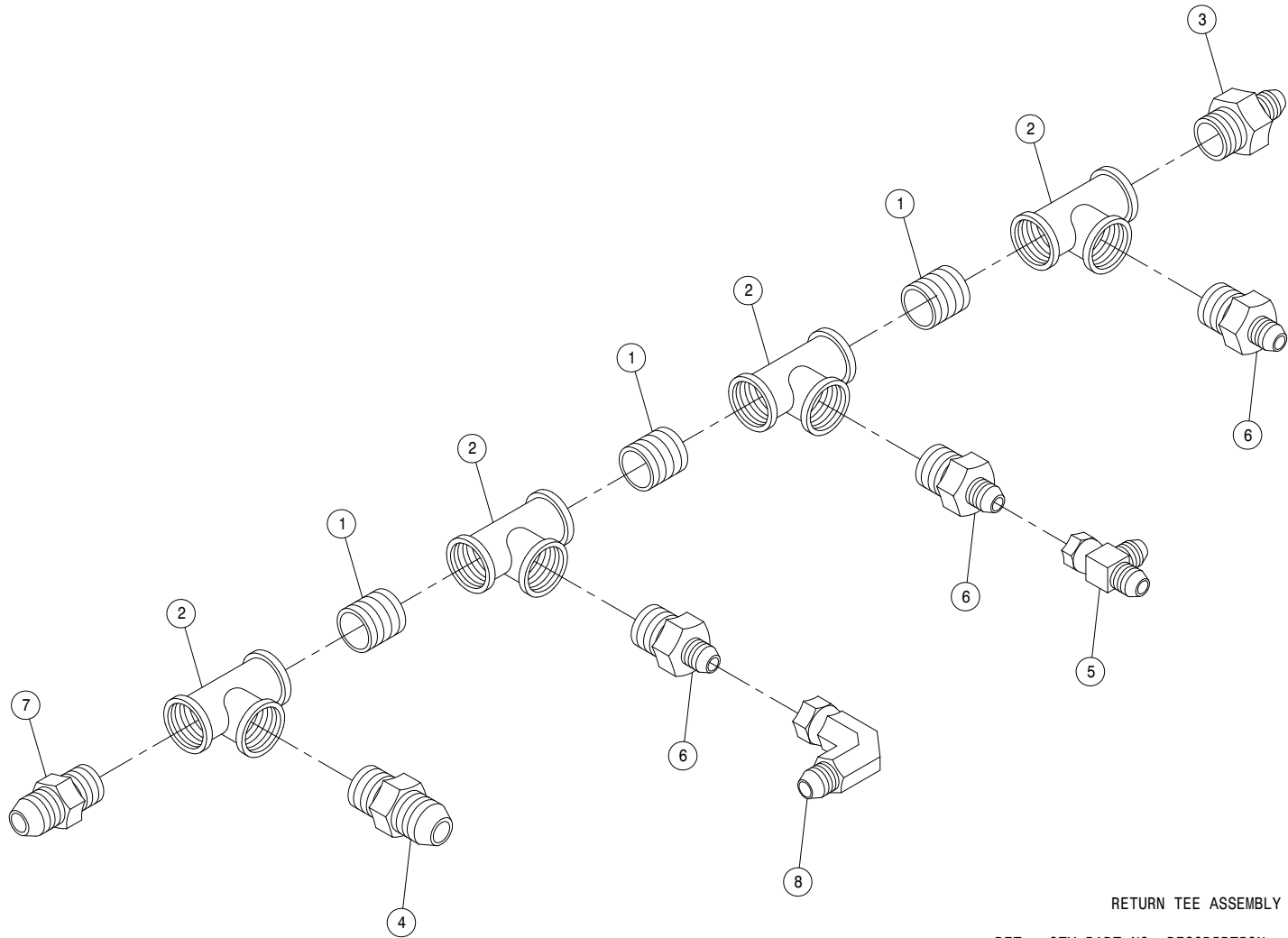

RETURN TEE ASSEMBLY

DET.	QTY	PART NO.	DESCRIPTION
	1	3	504702 CLOSE NIPPLE .75NPT
	2	4	504955 BLK PIPE TEE .75NPT
	3	1	610300 3/4MJC-3/4MNPT ADPTR
	4	1	618059 7/8MJC-3/4MNPT ADPTR
	5	1	618486 9/16FJIC SW RUN TEE-9/16MJC
	6	3	618642 9/16MJC-3/4MNPT ADPTR
	7	1	618108 1 1/16MJC-3/4MNPT ADPTR
	8	1	618618 9/16MJC-90-9/16FJIC SWIV LBO

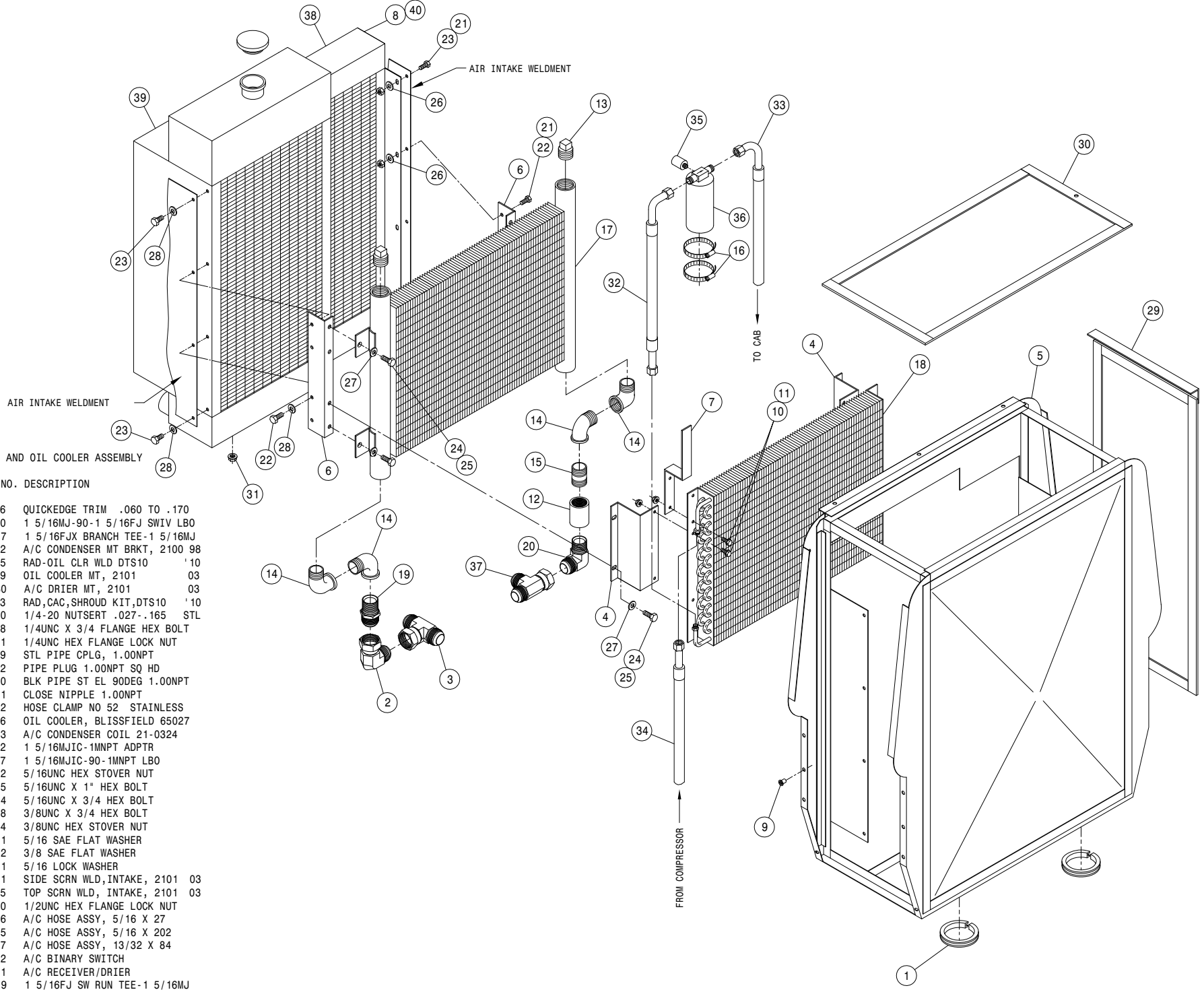

RADIATOR AND OIL COOLER ASSEMBLY

DET. QTY PART NO. DESCRIPTION

1	2	193016	QUICKEDGE TRIM .060 TO .170
2	1	618640	1 5/16MJ-90-1 5/16FJ SWIV LBO
3	1	618717	1 5/16FJX BRANCH TEE-1 5/16MJ
4	2	315022	A/C CONDENSER MT BRKT, 2100 98
5	1	315085	RAD-OIL CLR WLD DTS10 '10
6	2	315079	OIL COOLER MT, 2101 03
7	1	315080	A/C DRIER MT, 2101 03
8	1	315103	RAD,CAC,SHROUD KIT,DTS10 '10
9	16	470380	1/4-20 NUTSERT .027-.165 STL
10	6	470118	1/4UNC X 3/4 FLANGE HEX BOLT
11	6	470121	1/4UNC HEX FLANGE LOCK NUT
12	1	505109	STL PIPE CPLG, 1.00NPT
13	2	505102	PIPE PLUG 1.00NPT SQ HD
14	4	505200	BLK PIPE ST EL 90DEG 1.00NPT
15	1	505201	CLOSE NIPPLE 1.00NPT
16	2	520052	HOSE CLAMP NO 52 STAINLESS
17	1	618606	OIL COOLER, BLISSFIELD 65027
18	1	657423	A/C CONDENSER COIL 21-0324
19	1	618322	1 5/16MJIC-1MNPT ADPTR
20	1	618437	1 5/16MJIC-90-1MNPT LBO
21	4	914002	5/16UNC HEX STOVER NUT
22	4	900065	5/16UNC X 1" HEX BOLT
23	4	900064	5/16UNC X 3/4 HEX BOLT
24	8	900128	3/8UNC X 3/4 HEX BOLT
25	8	914004	3/8UNC HEX STOVER NUT
26	4	920001	5/16 SAE FLAT WASHER
27	8	920002	3/8 SAE FLAT WASHER
28	4	920501	5/16 LOCK WASHER
29	2	315071	SIDE SCR N WLD, INTAKE, 2101 03
30	1	315075	TOP SCR N WLD, INTAKE, 2101 03
31	2	470360	1/2UNC HEX FLANGE LOCK NUT
32	1	657416	A/C HOSE ASSY, 5/16 X 27
33	1	657465	A/C HOSE ASSY, 5/16 X 202
34	1	657417	A/C HOSE ASSY, 13/32 X 84
35	1	657422	A/C BINARY SWITCH
36	1	657421	A/C RECEIVER/DRIER
37	1	618619	1 5/16FJ SW RUN TEE-1 5/16MJ
38	1	315104	RADIATOR,DTS10 '10
39	1	315105	CHARGE AIR COOLER,DTS10 '10
40	1	315106	SHROUD, DTS10 '10

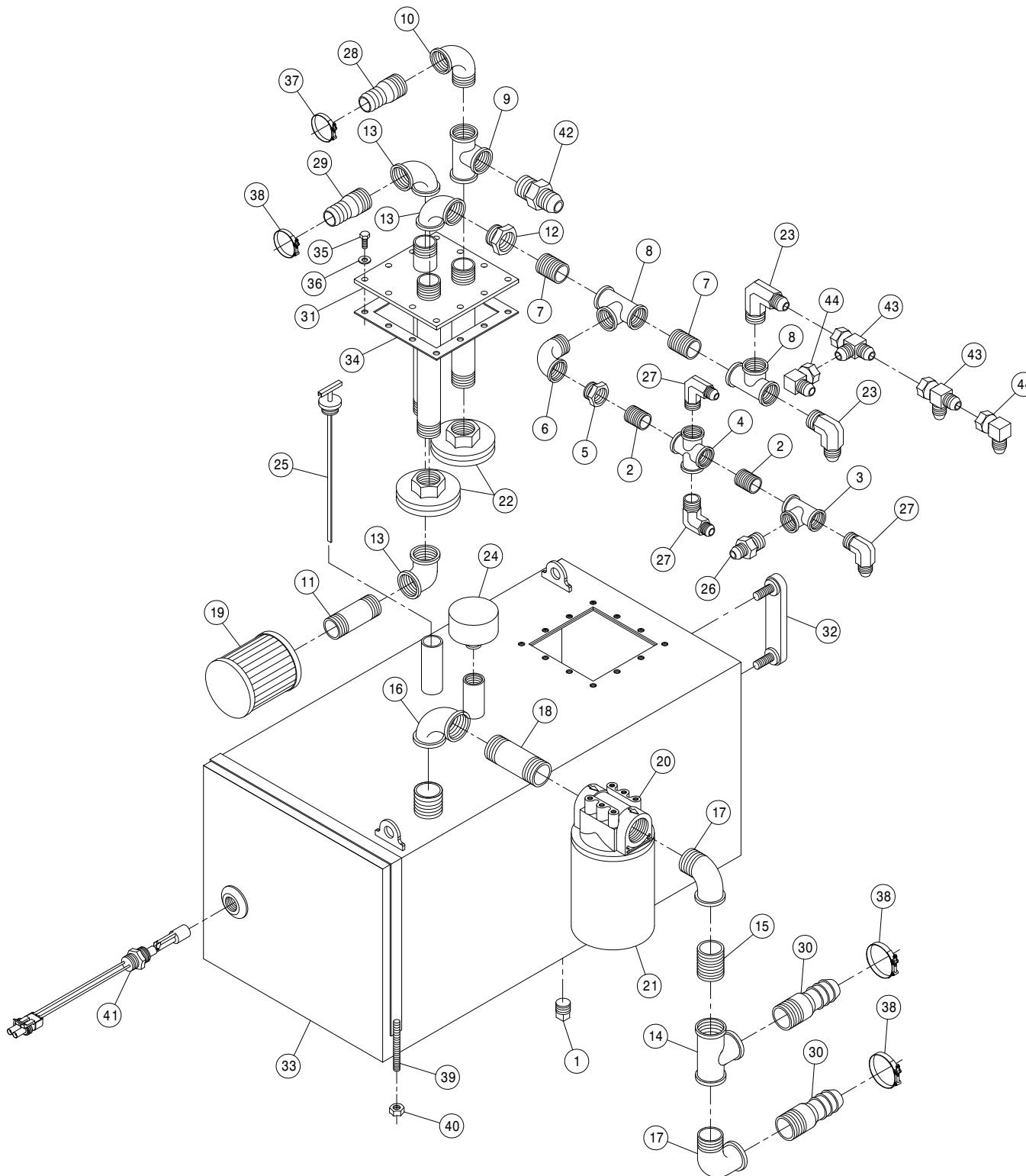

HYDRAULIC TANK ASSEMBLY

DET.	QTY	PART NO.	DESCRIPTION
	1	470308	1/2MNPT DRAIN PLUG,AL HD,MAG
	2	503600	CLOSE NIPPLE .50NPT
	3	503820	BLK PIPE TEE .50NPT
	4	503824	BLK PIPE CROSS .50NPT
	5	504210	RED BUSH 3/4 NPT X 1/2 NPT
	6	504610	BLK PIPE ST EL 90DEG .75NPT
	7	504702	CLOSE NIPPLE .75NPT
	8	504955	BLK PIPE TEE .75NPT
	9	505101	BLK PIPE TEE 1.00NPT
	10	505200	BLK PIPE ST EL 90DEG 1.00NPT
	11	505203	BLK PIPE NIPPLE 1.00NPT-4.00
	12	505213	RED BUSH 1 X 3/4 BLK MAL
	13	505300	BLK PIPE EL 90DEG 1.00NPT
	14	506105	BLK PIPE TEE 1.25NPT
	15	506200	CLOSE NIPPLE 1.25NPT
	16	506303	BLK PIPE EL 90DEG 1.25NPT
	17	506410	BLK PIPE ST EL 90DEG 1.25NPT
	18	506609	BLK PIPE NIPPLE 1.25NPT-6.00
	19	605600	TANK FILTER, 100 MESH,1"FNPT
	20	605601	PARKER FILTER ASSY,10M,1.25NPT
	21	605602	PARKER FILTER ELEMENT,10MICRON
	22	605603	LINE SUMP DIFFUSER
	23	610305	3/4MJIC-90-3/4MNPT LBO
	24	611052	FILLER BREATHER 3/4NPT
	25	614453	DIPSTICK, 8IN
	26	618018	9/16MJIC-1/2MNPT ADPTR
	27	618107	9/16MJIC-90-1/2MNPT LBO
	28	714331	1 NPT X 3/4 HOSE BARB
	29	714560	1NPT X 1 HOSE BARB
	30	715664	1 1/4 NPT X 1 HOSE BARB
	31	760090	RECEIVER PLT WLD 8240
	32	760177	SIGHT GAUGE W/TEMP, HYD TANK
	33	760268	HYD TANK WLD, 2100 2002
	34	763039	HYD MTR MTG PLT GSKT
	35	900064	5/16UNC X 3/4 HEX BOLT
	36	920001	5/16 SAE FLAT WASHER
	37	520137	1.12/1.25 T-BOLT HOSE CLAMP
	38	520138	1.38/1.56 T-BOLT HOSE CLAMP
	39	760212	HYD TANK STRAP WLD, 2100 98
	40	914004	3/8UNC HEX STOVER NUT
	41	470350	LIQUID LEVEL SWITCH ASSY,1/2NPT
	42	618322	1 5/16MJIC-1MNPT ADPTR
	43	618451	3/4FJIC SW RUN TEE-3/4MJIC
	44	618609	3/4MJIC-90-3/4FJIC SWIV LBO

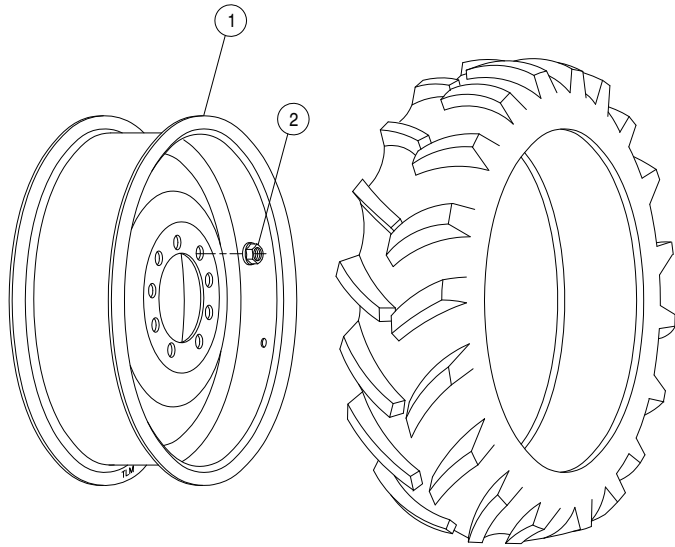

290/95R 34 *** RADIAL TIRE OPTION

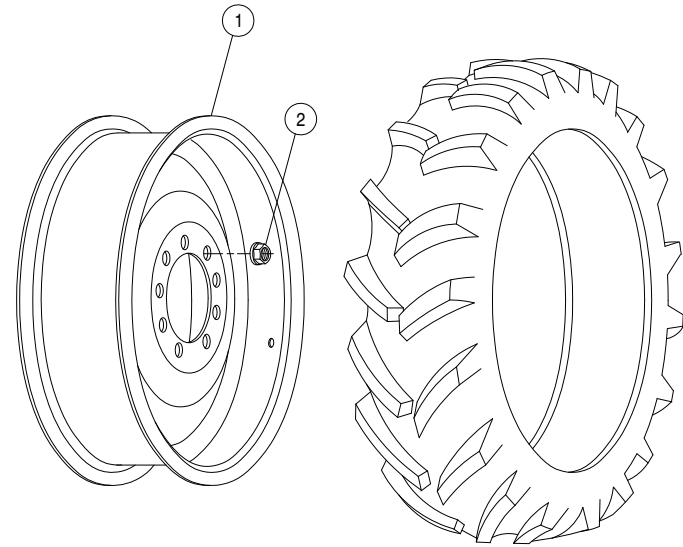

320/85R 34 *** RADIAL TIRE OPTION

TIRE AND RIM ASSEMBLIES

DET. QTY PART NO. DESCRIPTION

1	4	821042	RIM WLD, W10-34	98
2	36	470140	5/8UNF HEX SMTH FLANGE NUT PLT	

NOTE: QUANTITY SHOWN IS PER MACHINE

RIGHT FRONT LEG ASSEMBLY

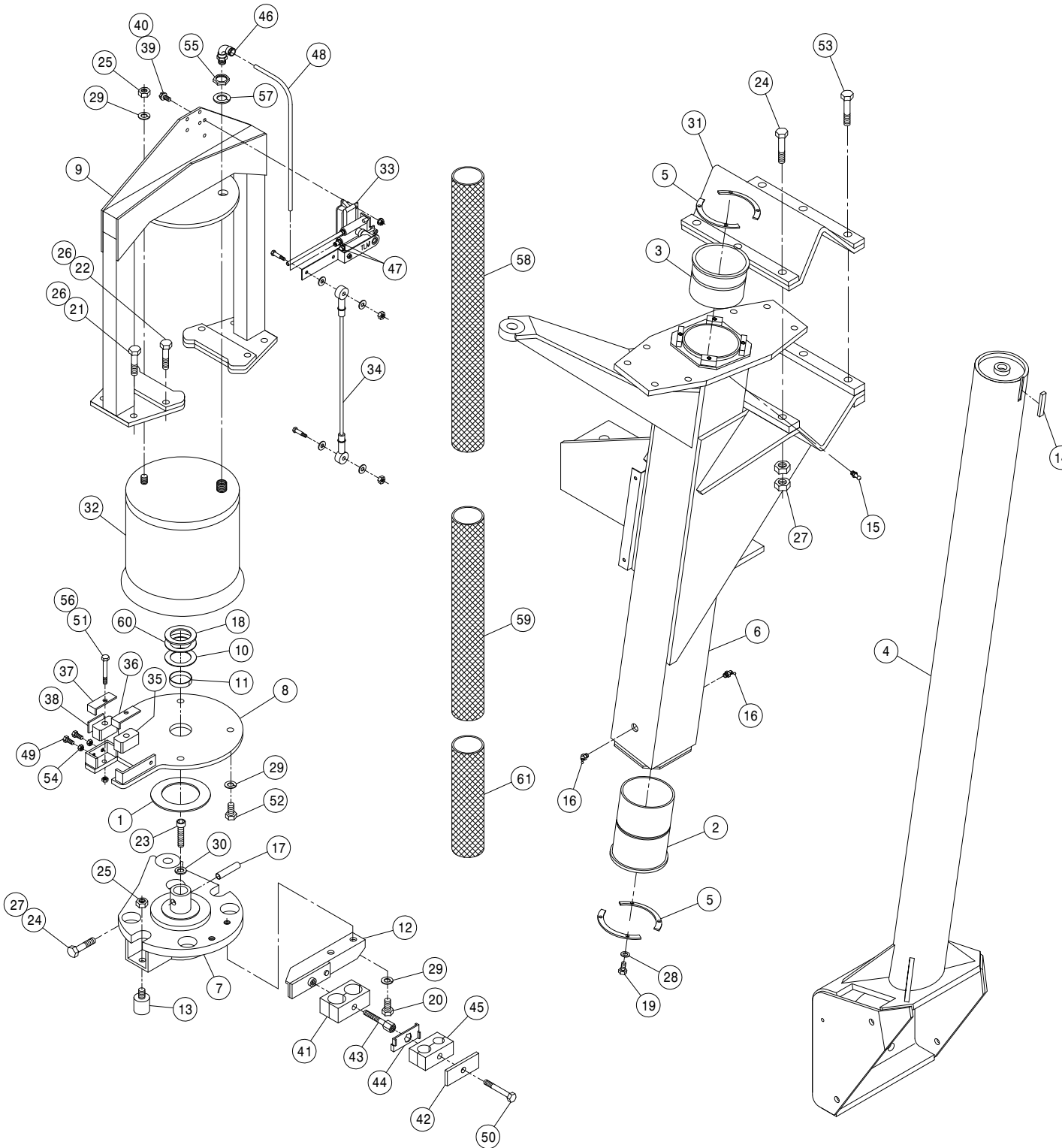

DET.	QTY	PART NO.	DESCRIPTION
1	1	127505	THRUST BEARING, FIBERGLIDE
2	1	358564	FRT LEG LWR NYL SLEEVE 280 89
3	1	358565	FRT LEG UPR NYL SLEEVE 280 89
4	1	359194	RF/LR INNER LEG WLD, 2100 02
5	4	358927	LWR BRG KPR, LEG 98
6	1	358954	RH FRT OUTER LEG WLD, 2100 99
7	1	358971	STEERING ARM WLD,RF/LR 2100 99
8	1	358980	AIR BAG MT WLD, RF/LR 2100 99
9	1	358985	AIR BAG ARCH WLD,RF/LR 2100 99
10	1	358994	LEG WASHER, NYLON 2100 99
11	1	358995	NYLON BEARING,LWR AB MT2100 99
12	1	358996	RH UPPER HOSE MT WELD, 2100 99
13	2	470259	URETHANE BUMPER,1.25D X 1.25L
14	1	470265	.250 X .375 CFFL X 1.88 C/L
15	1	471005	GREASE ZERK, 1/4 28 X 1/2
16	2	471023	GREASE ZERK 1/4-28 X 45
17	1	473906	ROLL PIN, 1/2 X 2 1/2 COILED
18	1	483061	WASH: 7GA X 1.66 X 2.50
19	8	900064	5/16UNC X 3/4 HEX BOLT
20	2	900263	1/2UNC X 1" HEX BOLT
21	4	900265	1/2UNC X 1 1/2 HEX BOLT
22	4	900267	1/2UNC X 2" HEX BOLT
23	1	900390	5/8UNC X 2 1/2 SOCKET CAP SCR
24	4	900836	5/8UNF X 3 1/4 HEX BOLT GR8
25	3	910008	1/2UNC HEX NUT
26	8	914008	1/2UNC HEX STOVER NUT
27	14	914811	5/8UNF HEX NUT GR8
28	8	920501	5/16 LOCK WASHER
29	7	920504	1/2 LOCK WASHER
30	1	920505	5/8 LOCK WASHER
31	1	358759	LEG MT V-PLT WLD, 284T 94
32	1	358831	AIRIDE SPRING 98
33	1	358832	AIRIDE SPRING CTRL VALVE 98
34	1	358839	AIRRIDE CTRL LINK KIT, 2100 99
35	2	358990	NYLON GUIDE, 2100 LEG 99
36	1	358991	INNER KEEPER,NYL GUIDE,2100 99
37	1	358992	OUTER KEEPER,NYL GUIDE,2100 99
38	1	358993	.125 X 1.000 HRST X 1.68 C/L
39	2	470118	1/4UNC X 3/4 FLANGE HEX BOLT
40	2	470121	1/4UNC HEX FLANGE LOCK NUT
41	1	470271	HOSE CLAMP BODY,1.181-1.181
42	1	470276	CLAMP COVER PLATE,SNGL, 2.55LG
43	1	470280	STACK BOLT, 5/16UNC X 1 3/4
44	1	470281	STACK BOLT SAFETY LOCK PLATE
45	1	470282	HOSE CLAMP BODY, .53-.78
46	1	711040	1/4MNPT-90-1/4 NYL TUBE LBO
47	2	711036	1/8MNPT-1/4 NYL TUBE FTG
48	1	601413	HOSE, 1/4 X 8 AIR
49	2	900065	5/16UNC X 1" HEX BOLT
50	1	900068	5/16UNC X 1 3/4 HEX BOLT
51	2	900069	5/16UNC X 2" HEX BOLT
52	4	900264	1/2UNC X 1 1/4 HEX BOLT
53	3	900837	5/8UNF X 3 1/2 HEX BOLT GR8
54	2	910002	5/16UNC HEX NUT
55	1	910013	3/4UNF HEX NUT
56	2	914002	5/16UNC HEX STOVER NUT
57	1	920506	3/4 LOCK WASHER
58	1	342828	NYL HOSE SLEEVE,3.34ID X 65.00
59	1	342848	NYL HOSE SLEEVE,2.96ID X 36.00
60	1	483063	WASH: 14GA X 1.66 X 2.50
61	1	342654	NYL HOSE SLEEVE,3.66ID X 24.00

RIGHT FRONT LEG ASSEMBLY

DET.	QTY	PART NO.	DESCRIPTION
1	1	359185	WHL MTR SHLD, XP/2100 2002
2	1	358926	FRT LEG HYD TUBE BRKT, 2100 98
3	2	900263	1/2UNC X 1" HEX BOLT
4	1	470272	TUBE CLAMP BODY, .375- .500
5	1	470275	TUBE CLAMP BODY, 1.000-1.000
6	1	470277	CLAMP WELD PLATE, SNGL, 2.15LG
7	1	470278	CLAMP WELD PLATE, SNGL, 2.75LG
8	1	471023	GREASE ZERK 1/4-28 X 45
9	1	610013	ZERK BOLT, 5/8 X 1 1/4 TORQ HUB
10	1	610800	TORQ HUB, 18.78:1 W/O BRAKE
11	1	610637	SUND HYD MOTOR, M46-4019
12	1	615708	LWR HYD TUBE ASSY, LEG 2100 98
13	1	615709	UPR HYD TUBE ASSY, LEG 2100 98
14	1	615710	RF/LR HYD DRN TUBE ASSY 2100 98
15	1	615712	RF/LR HYD CTRL TUBE ASSY 2100 98
16	1	618119	9/16MJIC-90-9/16MOR LBO
17	2	618178	1 5/16MJIC-90-1 5/16MOR LBO
18	1	618474	3/4MJIC-90-1 1/16MOR LBO
19	1	662256	STALK GUIDE WLD, 2100 2000
20	1	870045	O-RING 4 1/8 OD X 4 ID
21	1	900068	5/16UNC X 1 3/4 HEX BOLT
22	1	900070	5/16UNC X 2 1/2 BOLT
23	3	920004	1/2 SAE FLAT WASHER
24	3	900264	1/2UNC X 1 1/4 HEX BOLT
25	1	900265	1/2UNC X 1 1/2 HEX BOLT
26	2	900266P	1/2UNC X 1 3/4 HEX BOLT
27	5	900332P	5/8UNC X 1 1/4 HEX BOLT
28	2	914002	5/16UNC HEX STOVER NUT
29	6	914008	1/2UNC HEX STOVER NUT
30	2	920504P	1/2 LOCK WASHER
31	6	920505P	5/8 LOCK WASHER
32	2	618577	1 5/16MJIC UNION
33	1	618314	3/4MJIC UNION
34	1	619010	9/16MJIC UNION
35	9	470140	5/8UNF SMTH FLANGE HEX NUT GR8
36	1	359014	FRT HYD TUBE MTG PLT, 2100 00

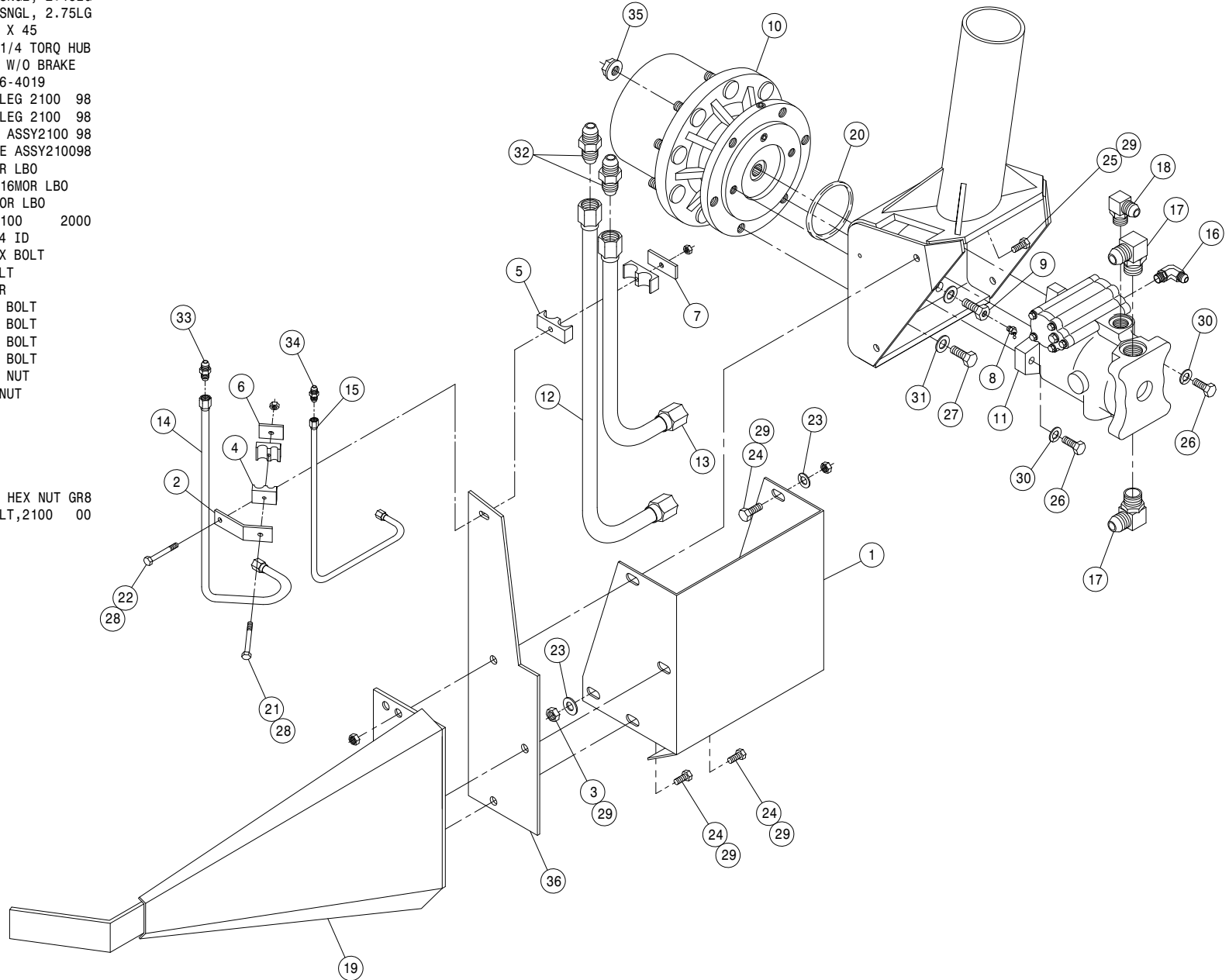

LEFT FRONT LEG ASSEMBLY

DET. QTY PART NO. DESCRIPTION

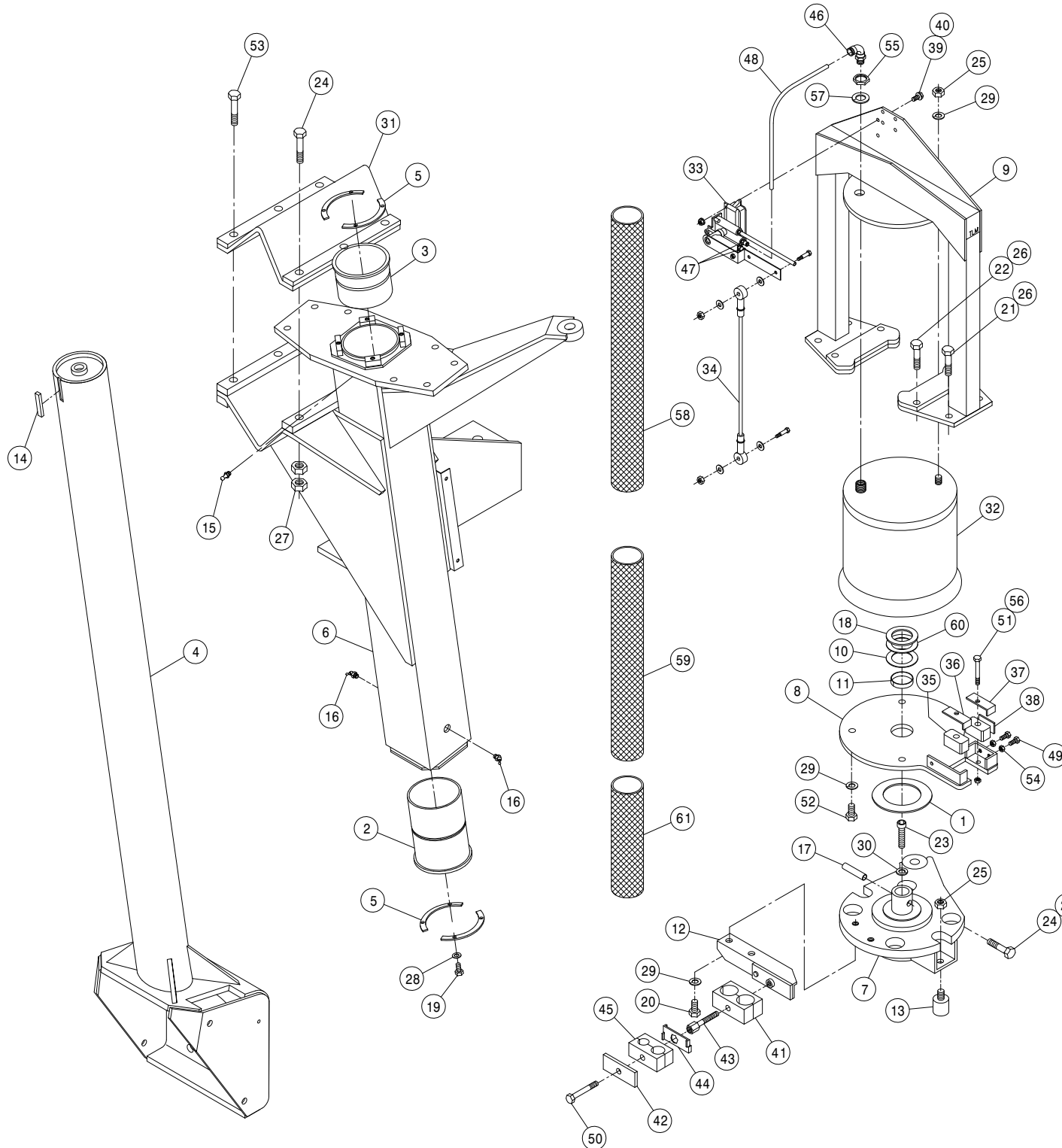

DET.	QTY	PART NO.	DESCRIPTION
1	1	127505	THRUST BEARING, FIBERGLIDE
2	1	358564	FRT LEG LWR NYL SLEEVE 280 89
3	1	358565	FRT LEG UPR NYL SLEEVE 280 89
4	1	359195	LF/RR INNER LEG WLD, 2100 02
5	4	358927	LWR BRG KPR, LEG 98
6	1	358955	LH FRT OUTER LEG WLD, 2100 99
7	1	358972	STEERING ARM WLD, LF/RR 2100 99
8	1	358981	AIR BAG MT WLD, LF/RR 2100 99
9	1	358986	AIR BAG ARCH WLD, LF/RR 2100 99
10	1	358994	LEG WASHER, NYLON 2100 99
11	1	358995	NYLON BEARING, LWR AB MT2100 99
12	1	358997	LH UPPER HOSE MT WELD, 2100 99
13	2	470259	URETHANE BUMPER, 1.25D X 1.25L
14	1	470265	.250 X .375 CFFL X 1.88 C/L
15	1	471005	GREASE ZERK, 1/4 28 X 1/2
16	2	471023	GREASE ZERK 1/4-28 X 45
17	1	473906	ROLL PIN, 1/2 X 2 1/2 COILED
18	1	483061	WASH: 7GA X 1.66 X 2.50
19	8	900064	5/16UNC X 3/4 HEX BOLT
20	2	900263	1/2UNC X 1" HEX BOLT
21	4	900265	1/2UNC X 1 1/2 HEX BOLT
22	4	900267	1/2UNC X 2" HEX BOLT
23	1	900390	5/8UNC X 2 1/2 SOCKET CAP SCR
24	4	900836	5/8UNF X 3 1/4 HEX BOLT GR8
25	3	910008	1/2UNC HEX NUT
26	8	914008	1/2UNC HEX STOVER NUT
27	14	914811	5/8UNF HEX NUT GR8
28	8	920501	5/16 LOCK WASHER
29	7	920504	1/2 LOCK WASHER
30	1	920505	5/8 LOCK WASHER
31	1	358759	LEG MT V-PLT WLD, 284T 94
32	1	358831	AIRIDE SPRING 98
33	1	358832	AIRIDE SPRING CTRL VALVE 98
34	1	358839	AIRIDE CTRL LINK KIT, 2100 99
35	2	358990	NYLON GUIDE, 2100 LEG 99
36	1	358991	INNER KEEPER, NYL GUIDE, 2100 99
37	1	358992	OUTER KEEPER, NYL GUIDE, 2100 99
38	1	358993	.125 X 1.000 HRST X 1.68 C/L
39	2	470118	1/4UNC X 3/4 FLANGE HEX BOLT
40	2	470121	1/4UNC HEX FLANGE LOCK NUT
41	1	470271	HOSE CLAMP BODY, 1.181-1.181
42	1	470276	CLAMP COVER PLATE, SNGL, 2.55LG
43	1	470280	STACK BOLT, 5/16UNC X 1 3/4
44	1	470281	STACK BOLT SAFETY LOCK PLATE
45	1	470282	HOSE CLAMP BODY, .53-.78
46	1	711040	1/4MNPT-90-1/4 NYL TUBE LBO
47	2	711036	1/8MNPT-1/4 NYL TUBE FTG
48	1	601413	HOSE, 1/4 X 8 AIR
49	2	900065	5/16UNC X 1" HEX BOLT
50	1	900068	5/16UNC X 1 3/4 HEX BOLT
51	2	900069	5/16UNC X 2" HEX BOLT
52	4	900264	1/2UNC X 1 1/4 HEX BOLT
53	3	900837	5/8UNF X 3 1/2 HEX BOLT GR8
54	2	910002	5/16UNC HEX NUT
55	1	910013	3/4UNF HEX NUT
56	2	914002	5/16UNC HEX STOVER NUT
57	1	920506	3/4 LOCK WASHER
58	1	342828	NYL HOSE SLEEVE, 3.34ID X 65.00
59	1	342848	NYL HOSE SLEEVE, 2.96ID X 36.00
60	1	483063	WASH: 14GA X 1.66 X 2.50
61	1	342654	NYL HOSE SLEEVE, 3.66ID X 24.00

LEFT FRONT LEG ASSEMBLY

DET.	QTY	PART NO.	DESCRIPTION
1	1	359185	WHL MTR SHLD, XP/2100 2002
2	1	358926	FRT LEG HYD TUBE BRKT, 2100 98
3	2	900263	1/2UNC X 1" HEX BOLT
4	1	470272	TUBE CLAMP BODY, .375-.500
5	1	470275	TUBE CLAMP BODY,1.000-1.000
6	1	470277	CLAMP WELD PLATE, SNGL, 2.15LG
7	1	470278	CLAMP WELD PLATE, SNGL, 2.75LG
8	1	471023	GREASE ZERK 1/4-28 X 45
9	1	610013	ZERK BOLT,5/8 X 1 1/4 TORQ HUB
10	1	610800	TORQ HUB, 18.78:1 W/O BRAKE
11	1	610637	SUND HYD MOTOR, M46-4019
12	1	615708	LWR HYD TUBE ASSY,LEG 2100 98
13	1	615808	UPR HYD TUBE ASSY,LEG 2100 03
14	1	615809	LF/RR HYD DRN TUBE ASSY2100 03
15	1	615713	LF/RR HYD CTRL TUBE ASSY210098
16	1	618119	9/16MJIC-90-9/16MOR LBO
17	2	618178	1 5/16MJIC-90-1 5/16MOR LBO
18	1	618474	3/4MJIC-90-1 1/16MOR LBO
19	1	662256	STALK GUIDE WLD, 2100 2000
20	1	870045	O-RING 4 1/8 OD X 4 ID
21	1	900068	5/16UNC X 1 3/4 HEX BOLT
22	1	900070	5/16UNC X 2 1/2 BOLT
23	3	920004	1/2 SAE FLAT WASHER
24	3	900264	1/2UNC X 1 1/4 HEX BOLT
25	1	900265	1/2UNC X 1 1/2 HEX BOLT
26	2	900266P	1/2UNC X 1 3/4 HEX BOLT
27	5	900332P	5/8UNC X 1 1/4 HEX BOLT
28	2	914002	5/16UNC HEX STOVER NUT
29	6	914008	1/2UNC HEX STOVER NUT
30	2	920504P	1/2 LOCK WASHER
31	6	920505P	5/8 LOCK WASHER
32	2	618577	1 5/16MJIC UNION
33	1	618314	3/4MJIC UNION
34	1	619010	9/16MJIC UNION
35	9	470140	5/8UNF SMTH FLANGE HEX NUT GR8
36	1	359014	FRT HYD TUBE MTG PLT,2100 00

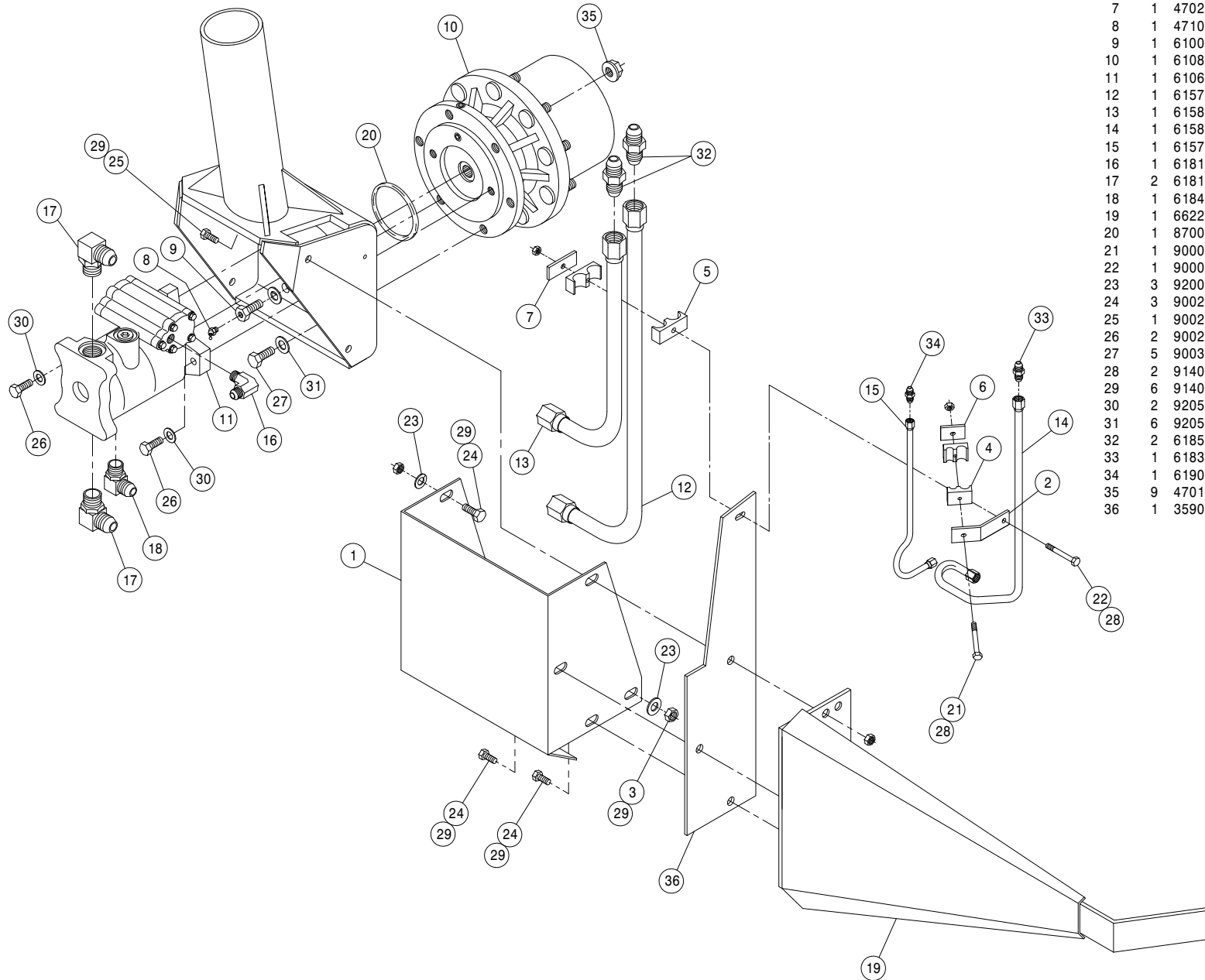

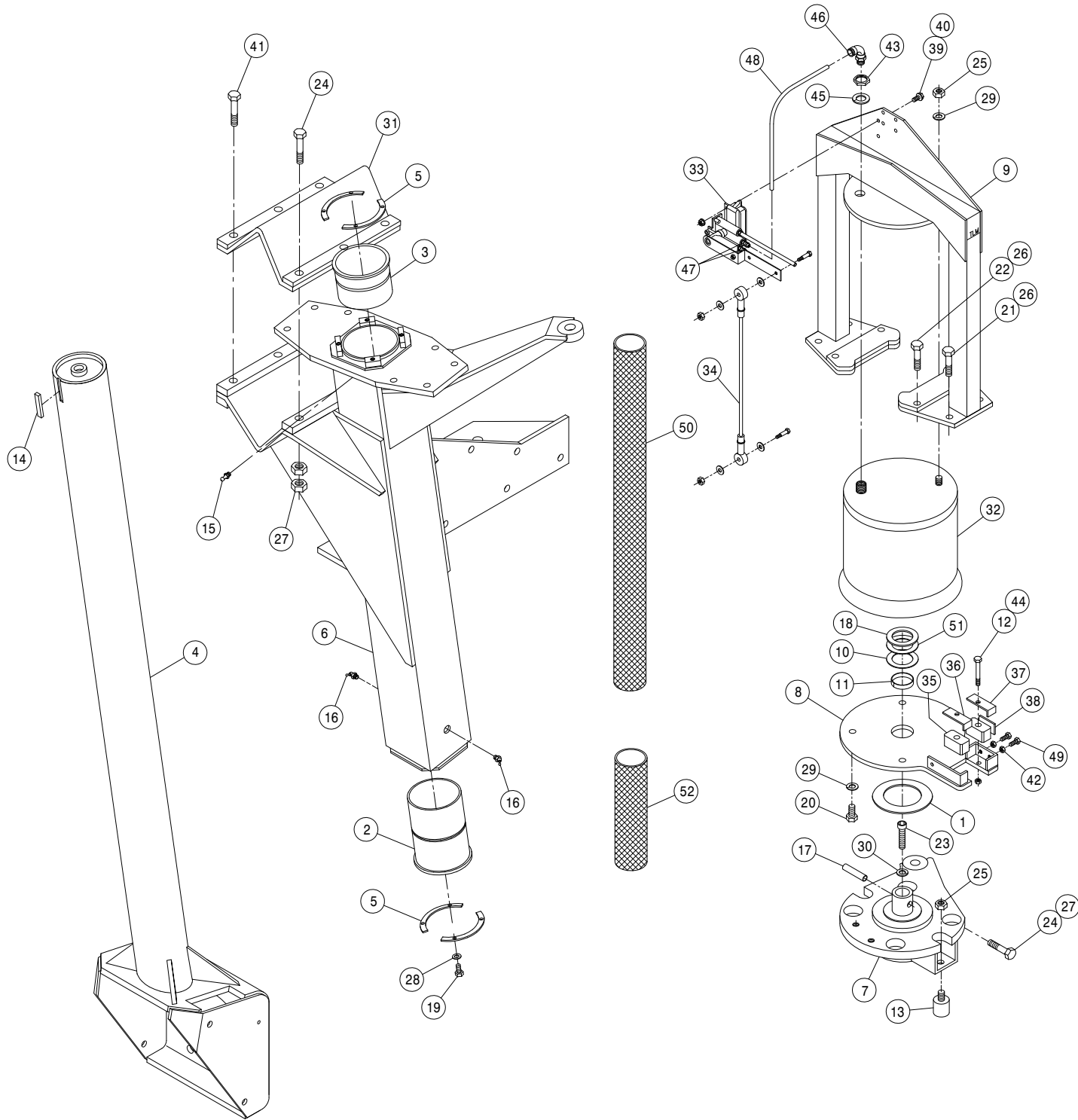

RIGHT REAR LEG ASSEMBLY

DET.	QTY	PART NO.	DESCRIPTION
1	1	483062	WASH: 11GA X 3.03 X 4.63
2	1	358564	FRT LEG LWR NYL SLEEVE 280 89
3	1	358565	FRT LEG UPR NYL SLEEVE 280 89
4	1	359195	LF/RR INNER LEG WLD, 2100 02
5	4	358927	LWR BRG KPR, LEG 98
6	1	358956	RH REAR OUTER LEG WLD,2100 99
7	1	358972	STEERING ARM WLD,LF/RR 2100 99
8	1	358981	AIR BAG MT WLD, LF/RR 2100 99
9	1	358986	AIR BAG ARCH WLD,LF/RR 2100 99
10	1	358994	LEG WASHER, NYLON 2100 99
11	1	358995	NYLON BEARING,LWR AB MT2100 99
12	2	900069	5/16UNC X 2" HEX BOLT
13	2	470259	URETHANE BUMPER,1.25D X 1.25L
14	1	470265	.250 X .375 CFLL X 1.88 C/L
15	1	471005	GREASE ZERK, 1/4 28 X 1/2
16	2	471023	GREASE ZERK 1/4-28 X 45
17	1	473906	ROLL PIN, 1/2 X 2 1/2 COILED
18	1	483061	WASH: 7GA X 1.66 X 2.50
19	8	900064	5/16UNC X 3/4 HEX BOLT
20	4	900264	1/2UNC X 1 1/4 HEX BOLT
21	4	900265	1/2UNC X 1 1/2 HEX BOLT
22	4	900267	1/2UNC X 2" HEX BOLT
23	1	900390	5/8UNC X 2 1/2 SOCKET CAP SCR
24	4	900836	5/8UNF X 3 1/4 HEX BOLT GR8
25	3	910008	1/2UNC HEX NUT
26	8	914008	1/2UNC HEX STOVER NUT
27	14	914811	5/8UNF HEX NUT GR8
28	8	920501	5/16 LOCK WASHER
29	5	920504	1/2 LOCK WASHER
30	1	920505	5/8 LOCK WASHER
31	1	358759	LEG MT V-PLT WLD, 284T 94
32	1	358831	AIRIDE SPRING 98
33	1	358832	AIRIDE SPRING CTRL VALVE 98
34	1	358839	AIRIDE CTRL LINK KIT, 2100 99
35	2	358990	NYLON GUIDE, 2100 LEG 99
36	1	358991	INNER KEEPER, NYL GUIDE,2100 99
37	1	358992	OUTER KEEPER,NYL GUIDE,2100 99
38	1	358993	.125 X 1.000 HRST X 1.68 C/L
39	2	470118	1/4UNC X 3/4 FLANGE HEX BOLT
40	2	470121	1/4UNC HEX FLANGE LOCK NUT
41	3	900837	5/8UNF X 3 1/2 HEX BOLT GR8
42	2	910002	5/16UNC HEX NUT
43	1	910013	3/4UNF HEX NUT
44	2	914002	5/16UNC HEX STOVER NUT
45	1	920506	3/4 LOCK WASHER
46	1	711040	1/4MNPT-90-1/4 NYL TUBE LBO
47	2	711036	1/8MNPT-1/4 NYL TUBE FTG
48	1	601413	HOSE, 1/4 X 8 AIR
49	2	900065	5/16UNC X 1" HEX BOLT
50	1	342828	NYL HOSE SLEEVE,3.34ID X 65.00
51	1	483063	WASH: 14GA X 1.66 X 2.50
52	1	342654	NYL HOSE SLEEVE,3.66ID X 24.00

RIGHT REAR LEG ASSEMBLY

DET.	QTY	PART NO.	DESCRIPTION
1	1	359185	WHL MTR SHLD, XP/2100 2002
2	1	358934	REAR LEG HYD TUBE BRKT,2100 98
3	1	618634	9/16MJIC-45-9/16FJIC SWIV LBO
4	1	470273	TUBE CLAMP BODY, .375-.375-.500
5	1	470275	TUBE CLAMP BODY,1.000-1.000
6	1	470277	CLAMP WELD PLATE, SNGL, 2.15LG
7	1	470278	CLAMP WELD PLATE, SNGL, 2.75LG
8	1	471023	GREASE ZERK 1/4-28 X 45
9	1	610013	ZERK BOLT,5/8 X 1 1/4 TORQ HUB
10	1	610803	TORQ HUB, 24.40:1 W/BRAKE
11	1	608000	SAUER HYD MOTOR, M46-4024
12	1	615708	LWR HYD TUBE ASSY,LEG 2100 98
13	1	615808	UPR HYD TUBE ASSY,LEG 2100 03
14	1	615809	LF/RR HYD DRN TUBE ASSY2100 03
15	1	615713	LF/RR HYD CTRL TUBE ASSY210098
16	1	618119	9/16MJIC-90-9/16MOR LBO
17	2	618178	1 5/16MJIC-90-1 5/16MOR LBO
18	1	618474	3/4MJIC-90-1 1/16MOR LBO
19	1	662256	STALK GUIDE WLD, 2100 2000
20	1	870045	O-RING 4 1/8 OD X 4 ID
21	1	900068	5/16UNC X 1 3/4 HEX BOLT
22	1	900070	5/16UNC X 2 1/2 BOLT
23	2	920004	1/2 SAE FLAT WASHER
24	6	900264	1/2UNC X 1 1/4 HEX BOLT
25	2	900263	1/2UNC X 1" HEX BOLT
26	2	900266P	1/2UNC X 1 3/4 HEX BOLT
27	5	900332P	5/8UNC X 1 1/4 HEX BOLT
28	2	914002	5/16UNC HEX STOVER NUT
29	8	914008	1/2UNC HEX STOVER NUT
30	2	920504P	1/2 LOCK WASHER
31	6	920505P	5/8 LOCK WASHER
32	2	618577	1 5/16MJIC UNION
33	1	618314	3/4MJIC UNION
34	2	619010	9/16MJIC UNION
35	9	470140	5/8UNF SMTH FLANGE HEX NUT GR8
36	1	359014	FRT HYD TUBE MTG PLT,2100 00
37	1	615815	RH HYD BRAKE TUBE ASSY,2101 04
38	1	618304	9/16MJIC-7/16MOR ADPTR

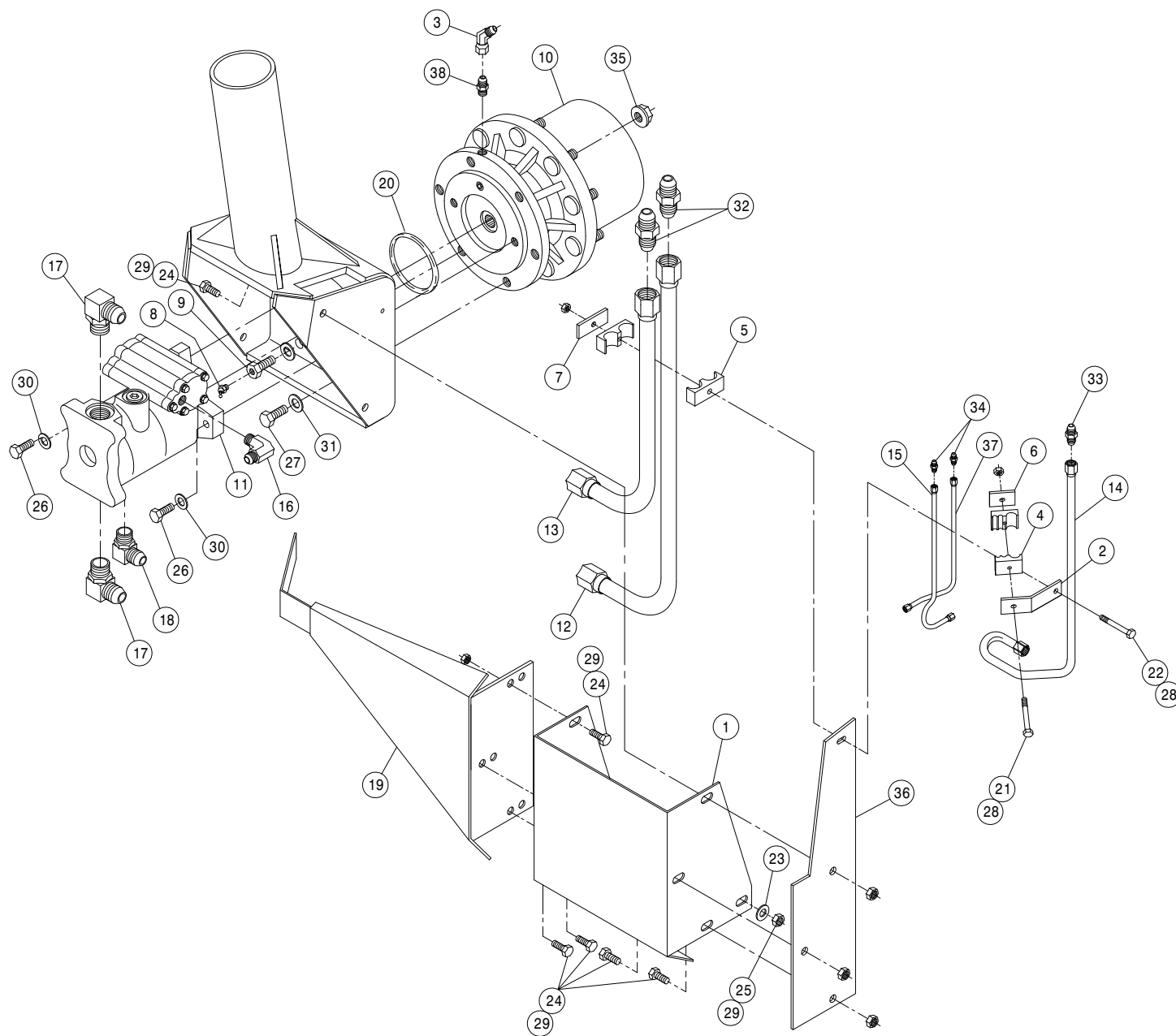

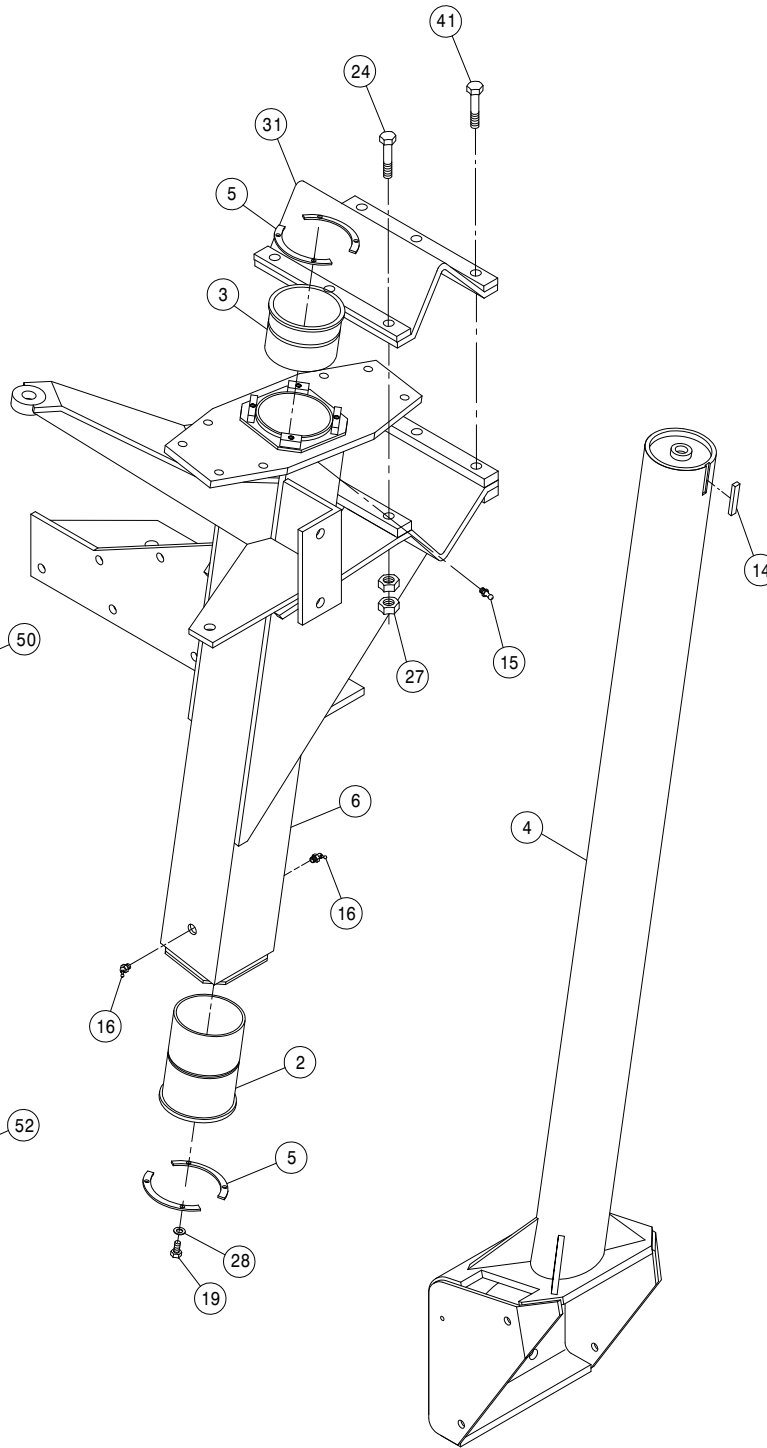
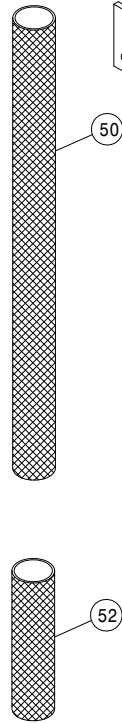
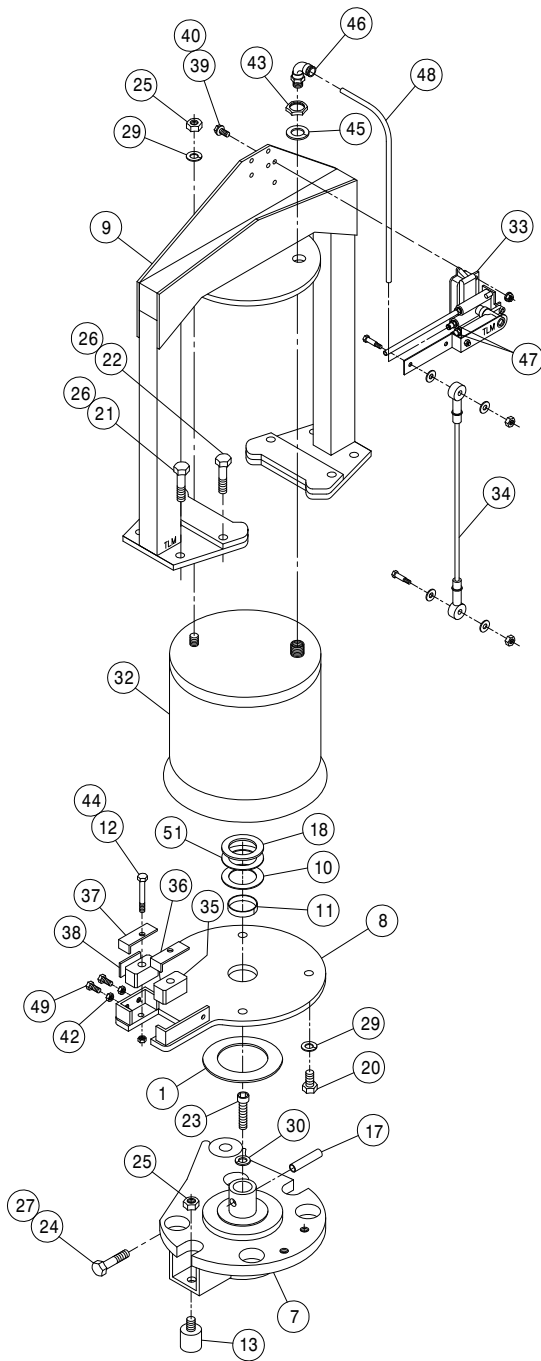

LEFT REAR LEG ASSEMBLY

DET.	QTY	PART NO.	DESCRIPTION
1	1	483062	WASH: 11GA X 3.03 X 4.63
2	1	358564	FRT LEG LWR NYL SLEEVE 280 89
3	1	358565	FRT LEG UPR NYL SLEEVE 280 89
4	1	359194	RF/LR INNER LEG WLD, 2100 02
5	4	358927	LWR BRG KPR, LEG 98
6	1	358957	LH REAR OUTER LEG WLD,2100 99
7	1	358971	STEERING ARM WLD,RF/LR 2100 99
8	1	358980	AIR BAG MT WLD, RF/LR 2100 99
9	1	358985	AIR BAG ARCH WLD,RF/LR 2100 99
10	1	358994	LEG WASHER, NYLON 2100 99
11	1	358995	NYLON BEARING,LWR AB MT2100 99
12	2	900069	5/16UNC X 2" HEX BOLT
13	2	470259	URETHANE BUMPER,1.25D X 1.25L
14	1	470265	.250 X .375 CFFL X 1.88 C/L
15	1	471005	GREASE ZERK, 1/4 28 X 1/2
16	2	471023	GREASE ZERK 1/4-28 X 45
17	1	473906	ROLL PIN, 1/2 X 2 1/2 COILED
18	1	483061	WASH: 7GA X 1.66 X 2.50
19	8	900064	5/16UNC X 3/4 HEX BOLT
20	4	900264	1/2UNC X 1 1/4 HEX BOLT
21	4	900265	1/2UNC X 1 1/2 HEX BOLT
22	4	900267	1/2UNC X 2" HEX BOLT
23	1	900390	5/8UNC X 2 1/2 SOCKET CAP SCR
24	4	900836	5/8UNF X 3 1/4 HEX BOLT GR8
25	3	910008	1/2UNC HEX NUT
26	8	914008	1/2UNC HEX STOVER NUT
27	14	914811	5/8UNF HEX NUT GR8
28	8	920501	5/16 LOCK WASHER
29	5	920504	1/2 LOCK WASHER
30	1	920505	5/8 LOCK WASHER
31	1	358759	LEG MT V-PLT WLD, 284T 94
32	1	358831	AIRIDE SPRING 98
33	1	358832	AIRIDE SPRING CTRL VALVE 98
34	1	358839	AIRIDE CTRL LINK KIT, 2100 99
35	2	358990	NYLON GUIDE, 2100 LEG 99
36	1	358991	INNER KEEPER,NYL GUIDE,2100 99
37	1	358992	OUTER KEEPER,NYL GUIDE,2100 99
38	1	358993	.125 X 1.000 HRST X 1.68 C/L
39	2	470118	1/4UNC X 3/4 FLANGE HEX BOLT
40	2	470121	1/4UNC HEX FLANGE LOCK NUT
41	3	900837	5/8UNF X 3 1/2 HEX BOLT GR8
42	2	910002	5/16UNC HEX NUT
43	1	910013	3/4UNF HEX NUT
44	2	914002	5/16UNC HEX STOVER NUT
45	1	920506	3/4 LOCK WASHER
46	1	711040	1/4MNPT-90-1/4 NYL TUBE LBO
47	2	711036	1/8MNPT-1/4 NYL TUBE FTG
48	1	601413	HOSE, 1/4 X 8 AIR
49	2	900065	5/16UNC X 1" HEX BOLT
50	1	342828	NYL HOSE SLEEVE,3.34ID X 65.00
51	1	483063	WASH: 14GA X 1.66 X 2.50
52	1	342654	NYL HOSE SLEEVE,3.66ID X 24.00

LEFT REAR LEG ASSEMBLY

DET. QTY PART NO. DESCRIPTION

1	1	359185	WHL MTR SHLD, XP/2100	2002
2	1	358934	REAR LEG HYD TUBE BRKT,2100	98
3	1	618634	9/16MJIC-45-9/16FJIC SWIV LBO	
4	1	470273	TUBE CLAMP BODY, .375-.375-.500	
5	1	470275	TUBE CLAMP BODY, 1.000-1.000	
6	1	470277	CLAMP WELD PLATE, SNGL, 2.15LG	
7	1	470278	CLAMP WELD PLATE, SNGL, 2.75LG	
8	1	471023	GREASE ZERK 1/4-28 X 45	
9	1	610013	ZERK BOLT, 5/8 X 1 1/4 TORQ HUB	
10	1	610803	TORQ HUB, 24.40:1 W/BRAKE	
11	1	608004	SAUER WHL MOTOR, M46-4194 W/SEN	
12	1	615708	LWR HYD TUBE ASSY, LEG 2100	98
13	1	615709	UPR HYD TUBE ASSY, LEG 2100	98
14	1	615710	RF/LR HYD DRN TUBE ASSY 2100	98
15	1	615712	RF/LR HYD CTRL TUBE ASSY 2100	98
16	1	618119	9/16MJIC-90-9/16MOR LBO	
17	2	618178	1 5/16MJIC-90-1 5/16MOR LBO	
18	1	618474	3/4MJIC-90-1 1/16MOR LBO	
19	1	662256	STALK GUIDE WLD, 2100	2000
20	1	870045	O-RING 4 1/8 OD X 4 ID	
21	1	900068	5/16UNC X 1 3/4 HEX BOLT	
22	1	900070	5/16UNC X 2 1/2 BOLT	
23	2	920004	1/2 SAE FLAT WASHER	
24	6	900264	1/2UNC X 1 1/4 HEX BOLT	
25	2	900263	1/2UNC X 1" HEX BOLT	
26	2	900266P	1/2UNC X 1 3/4 HEX BOLT	
27	5	900332P	5/8UNC X 1 1/4 HEX BOLT	
28	2	914002	5/16UNC HEX STOVER NUT	
29	8	914008	1/2UNC HEX STOVER NUT	
30	2	920504P	1/2 LOCK WASHER	
31	6	920505P	5/8 LOCK WASHER	
32	2	618577	1 5/16MJIC UNION	
33	1	618314	3/4MJIC UNION	
34	2	619010	9/16MJIC UNION	
35	9	470140	5/8UNF SMTH FLANGE HEX NUT GR8	
36	1	359014	FRT HYD TUBE MTG PLT, 2100	00
37	1	615814	LH HYD BRAKE TUBE ASSY, 2101	04
38	1	618304	9/16MJIC-7/16MOR ADPTR	
39	1	606192	SPEED SENSOR, WHEEL MTR	606183

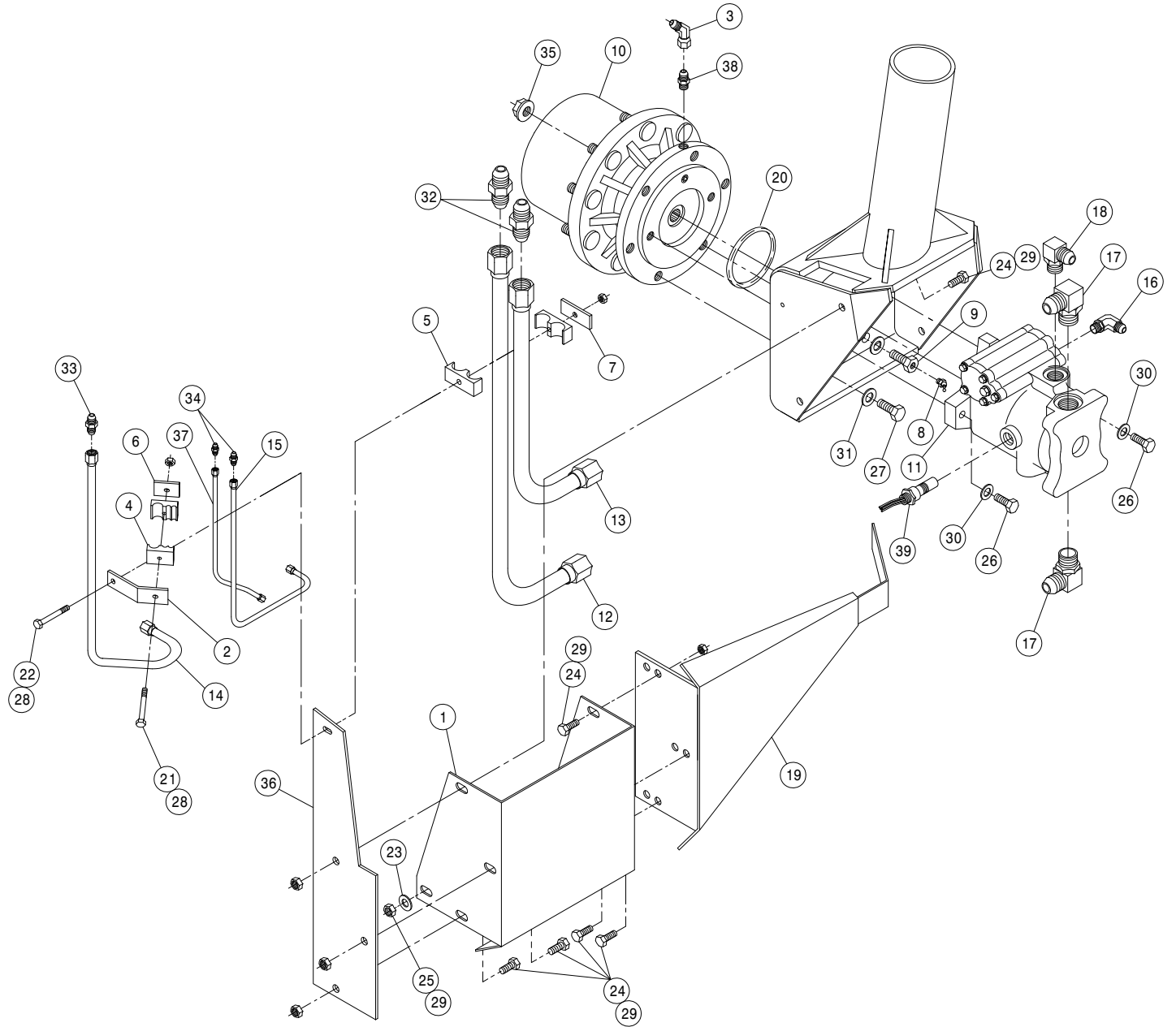

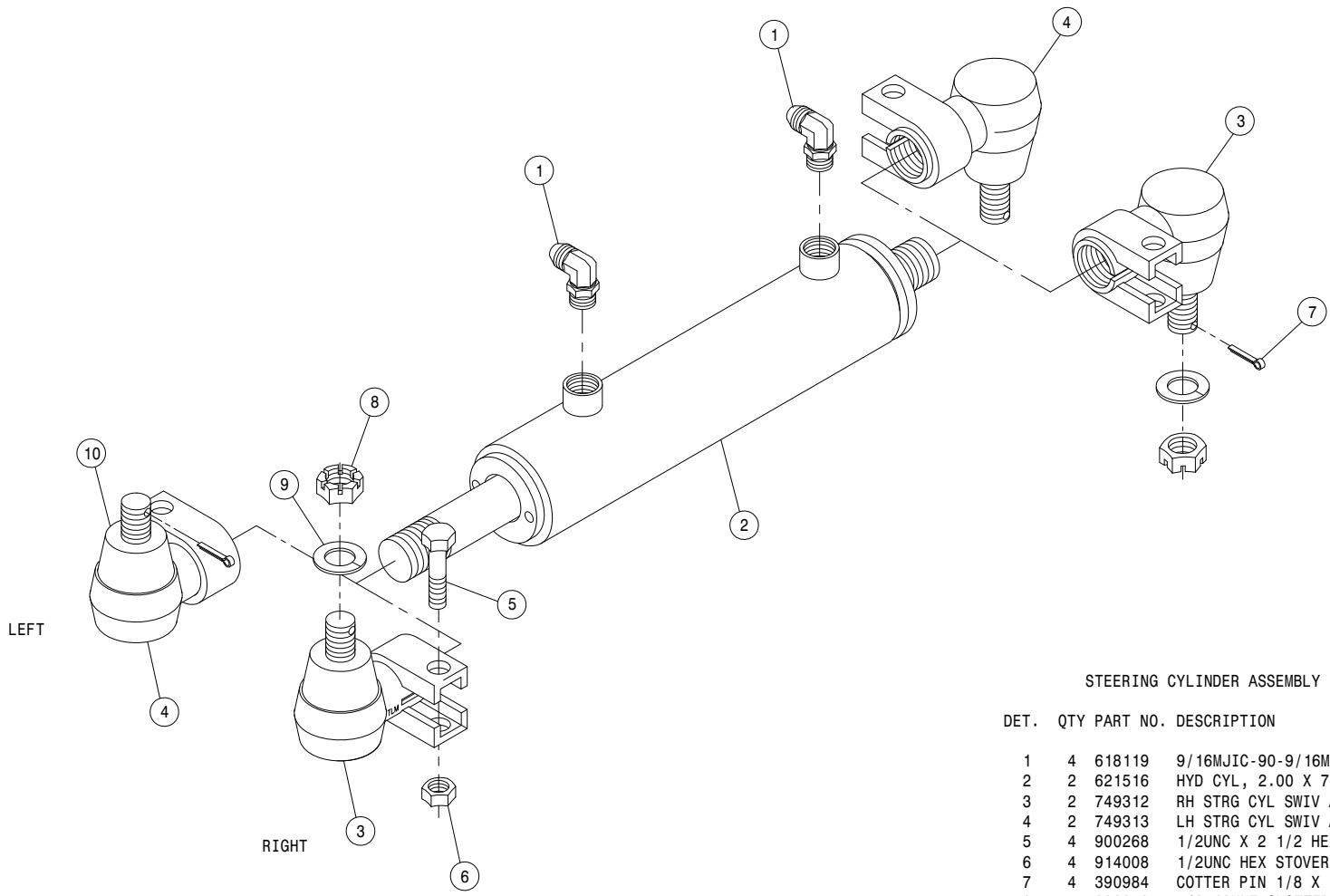

STEERING CYLINDER ASSEMBLY

DET.	QTY	PART NO.	DESCRIPTION
1	4	618119	9/16MJIC-90-9/16MOR LBO
2	2	621516	HYD CYL, 2.00 X 7.00 X 1.000
3	2	749312	RH STRG CYL SWIV ASSY
4	2	749313	LH STRG CYL SWIV ASSY
5	4	900268	1/2UNC X 2 1/2 HEX BOLT
6	4	914008	1/2UNC HEX STOVER NUT
7	4	390984	COTTER PIN 1/8 X 1 1/4
8	4	822040	5/8-18UNF SLOTTED HEX NUT
9	4	920505	5/8 LOCK WASHER
10	4	749330	RUBBER DUST SEAL, (749312/313)
11	2	621517	REPAIR KIT, HYD CYL 621516

NOTE: 1. 621205 - RH STEERING CYLINDER ASSEMBLY W/CYL SWIV DET.3
 2. 621206 - LH STEERING CYLINDER ASSEMBLY W/CYL SWIV DET.4

NOTE: QUANTITY SHOWN IS PER MACHINE

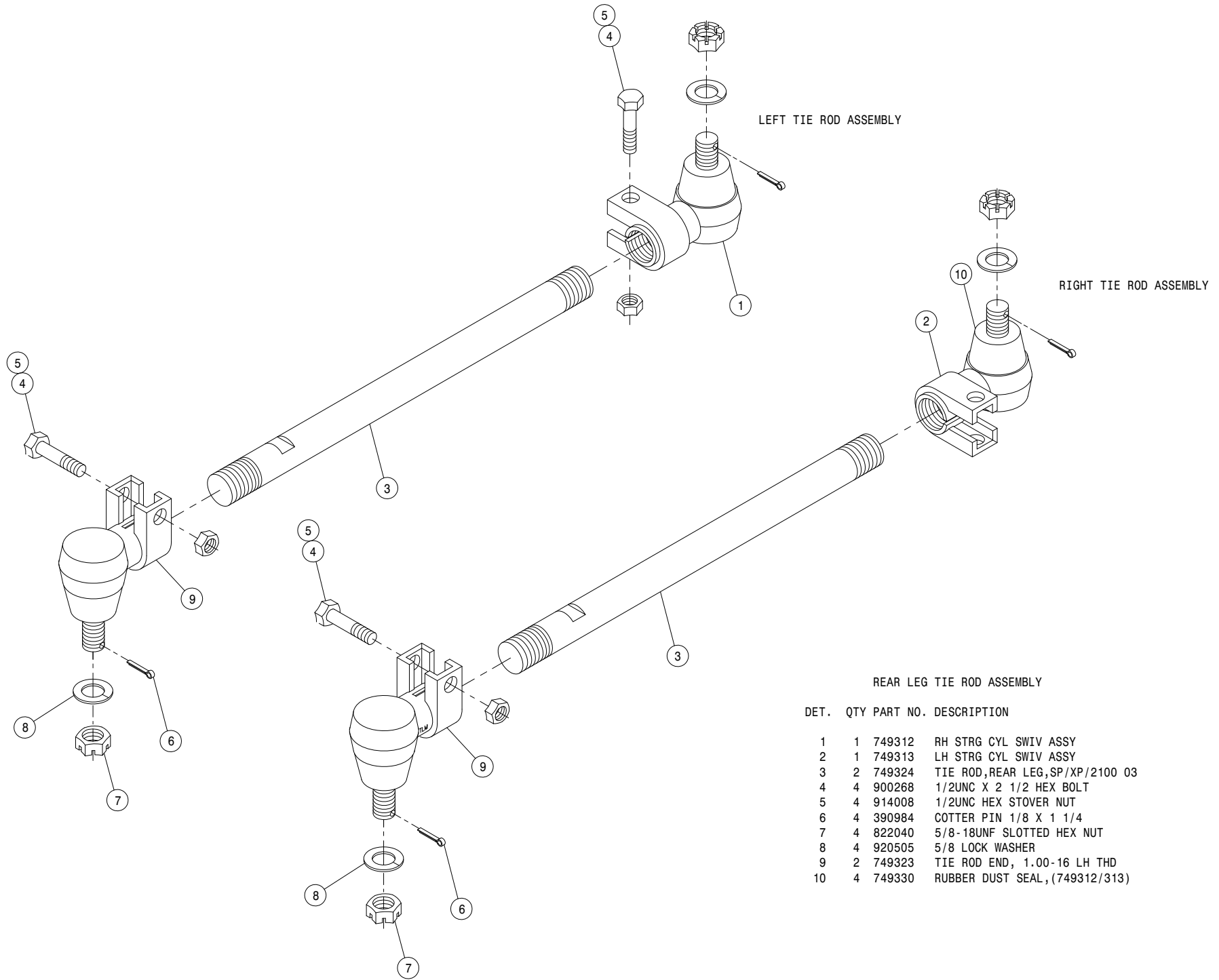

REAR LEG TIE ROD ASSEMBLY

DET.	QTY	PART NO.	DESCRIPTION
1	1	749312	RH STRG CYL SWIV ASSY
2	1	749313	LH STRG CYL SWIV ASSY
3	2	749324	TIE ROD, REAR LEG, SP/XP/2100 03
4	4	900268	1/2UNC X 2 1/2 HEX BOLT
5	4	914008	1/2UNC HEX STOVER NUT
6	4	390984	COTTER PIN 1/8 X 1 1/4
7	4	822040	5/8-18UNF SLOTTED HEX NUT
8	4	920505	5/8 LOCK WASHER
9	2	749323	TIE ROD END, 1.00-16 LH THD
10	4	749330	RUBBER DUST SEAL, (749312/313)

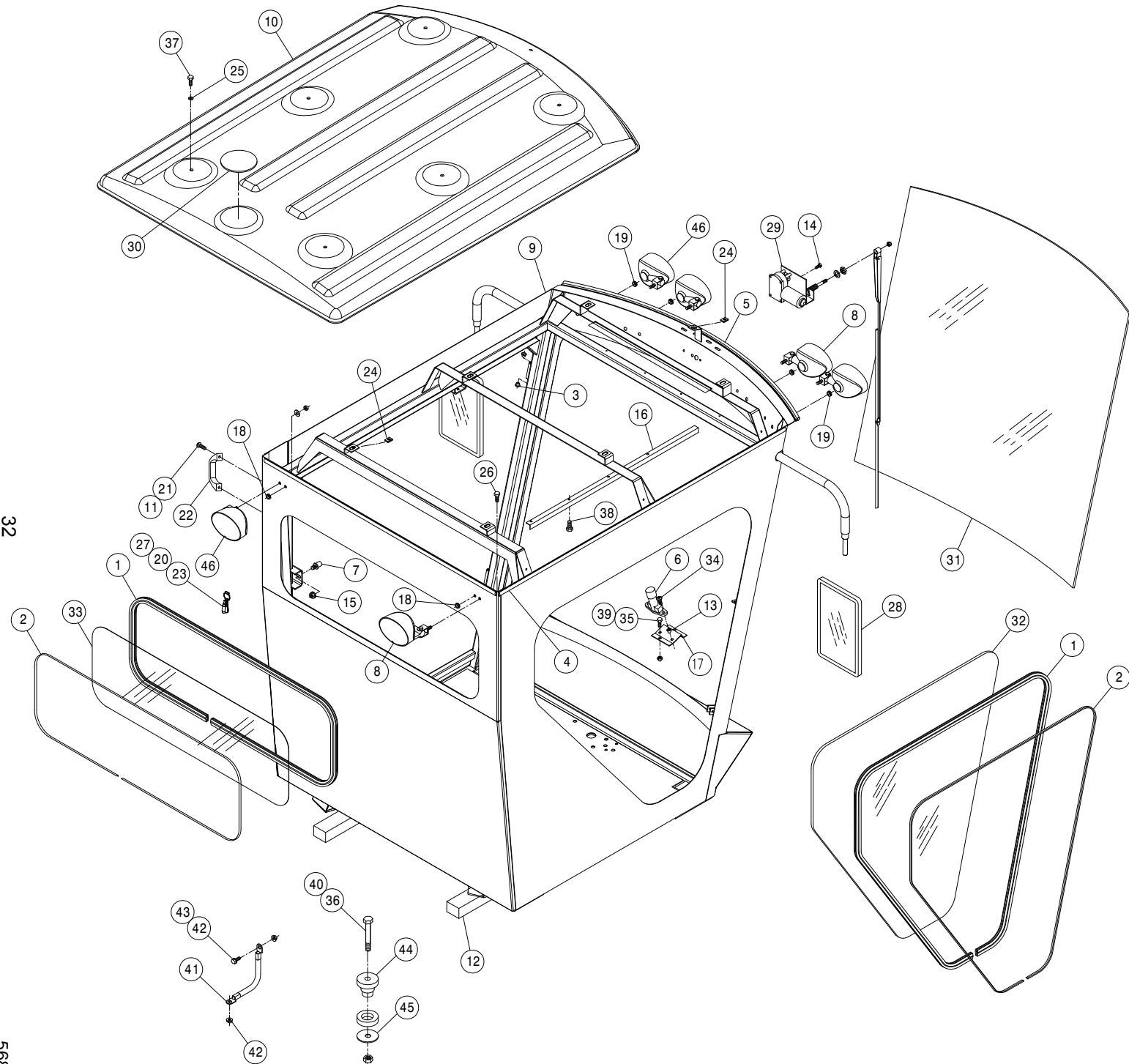

CAB ASSEMBLY

DET.	QTY	PART NO.	DESCRIPTION
1	26	193044	WINDOW WEATHERSTRIP
2	26	193045	LOCK STRIP FOR 193044
3	4	127502	NYLON FLANGE BRG
4	15	193062	SEAL, .592 X .750 D-SECT EPDM
5	5	193063	EDGE SEAL, EPDM G-7015
6	1	290412	DIMMER SWITCH
7	1	470417	STRIKER PIN ASSY
8	3	291902	RH WORKLIGHT, TRAPEZOID GLASS
9	1	343758	CAB FRAME WELD, DTS10 '10
10	1	343329	CAB ROOF, DTS 10 '05
11	2	903883	10-32 X 1/2 PHIL PAN MACH SCR
12	2	659704	FOAM, 2"THK X 2" WIDE X 42"LG
13	2	470380	1/4-20 NUTSERT .027-.165 STL
14	2	473862	1/4UNF X 5/8 HEX BOLT SS
15	1	470360	1/2UNC HEX FLANGE LOCK NUT
16	1	342420	HEAD LINER ANGLE, RH, 2100 98
17	1	342642	SOLU SWITCH ADPTR BRKT,2100 98
18	2	470067	GROMMET, .250ID .125GW .375GD
19	4	470070	GROMMET, .375ID .062GW .500GD
20	1	470398	BEAD CHAIN, #10 X 4" LONG
21	2	470175	10-32 HEX FLANGE LOCK NUT
22	1	470222	GRAB HANDLE, BLACK MOULDED
23	1	470397	RES-Q-ME TOOL
24	7	470261	3/8UNC U-NUT, .75 CLIP ON
25	7	470262	3/8 X 1" BONDED SEALING WASH
26	1	472349	1/4 X 3/4 20THD-IN TEK TYPE
27	1	470400	BEAD CHAIN CONNECTOR #10 WHITE
28	2	470348	MIRROR STS10 & STS12
29	1	470435	WINDSHIELD WIPER PKG DTS 10 05
30	1	343330	GPS MT PLATE, DTS 10 '05
31	1	658030	WINDSHIELD, GREEN DTS 10 '05
32	1	658023	SIDE CAB GLASS, GRAY 2100 98
33	1	658024	REAR CAB GLASS, GRAY 2100 98
34	2	903722	1/4UNC X3/4PHIL PANHD MACH SCR
35	2	900003	1/4UNC X 1" HEX BOLT
36	4	900829	5/8UNC X 4" HEX BOLT GR8
37	7	900129	3/8UNC X 1" SERR FLANGE BOLT
38	4	900263	1/2UNC X 1" HEX BOLT
39	2	914000	1/4UNC HEX STOVER NUT
40	4	914010	5/8UNC HEX STOVER NUT
41	1	290107	GROUND CABLE,8" X 4GA .406LUGS
42	2	470087	3/8UNC HEX FLANGE LOCK NUT
43	1	900128	3/8UNC X 3/4 HEX BOLT
44	4	311051	RUBBER MOUNT, RB3-350
45	4	311052	SNUBBING WASHER FOR 311051
46	3	291903	LH WORKLIGHT, TRAPEZOID GLASS

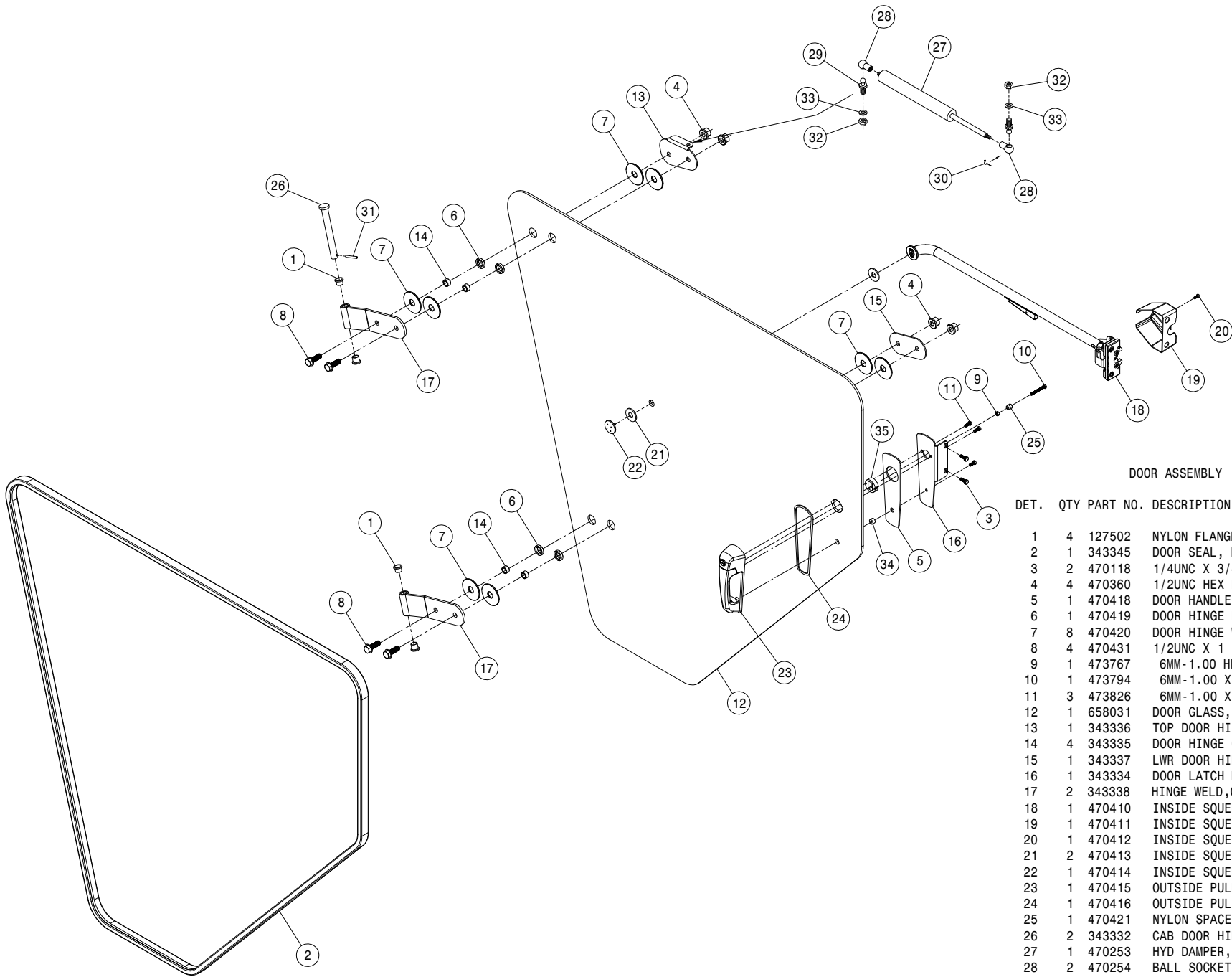

DOOR ASSEMBLY

DET.	QTY	PART NO.	DESCRIPTION
1	4	127502	NYLON FLANGE BRG
2	1	343345	DOOR SEAL, DTS 10 CAB 05
3	2	470118	1/4UNC X 3/4 FLANGE HEX BOLT
4	4	470360	1/2UNC HEX FLANGE LOCK NUT
5	1	470418	DOOR HANDLE MT GASKET, STS CAB
6	1	470419	DOOR HINGE BUSH, RUBBER STS 05
7	8	470420	DOOR HINGE WASH, RUBBER, STS 05
8	4	470431	1/2UNC X 1 1/2 FLANGE BOLT
9	1	473767	6MM-1.00 HEX NUT
10	1	473794	6MM-1.00 X 50MM HEX BOLT
11	3	473826	6MM-1.00 X 16MM HEX BOLT
12	1	658031	DOOR GLASS, GRAY DTS 10 05
13	1	343336	TOP DOOR HINGE PLT, DTS 10, 05
14	4	343335	DOOR HINGE GLASS BUSH, CAB 05
15	1	343337	LWR DOOR HINGE BACK PLT, 05
16	1	343334	DOOR LATCH BRKT PLT, CAB 05
17	2	343338	HINGE WELD, CAB 05
18	1	470410	INSIDE SQUEEZE LATCH ASSY
19	1	470411	INSIDE SQUEEZE LATCH COVER 05
20	1	470412	INSIDE SQUEEZE LATCH SCREWS
21	2	470413	INSIDE SQUEEZE LATCH GASKET
22	1	470414	INSIDE SQUEEZE LATCH CAP
23	1	470415	OUTSIDE PULL HANDLE ASSY
24	1	470416	OUTSIDE PULL HANDLE GASKET
25	1	470421	NYLON SPACER, SPHERICAL 6MMX12
26	2	343332	CAB DOOR HINGE PIN, SS 05
27	1	470253	HYD DAMPER, 100LB, 4" STROKE 1084
28	2	470254	BALL SOCKET, M6 THD X 10MM
29	2	470255	BALL STUD, 5/16-18 THD X 10MM
30	2	470256	SAFTY CLIP, 10MM BALL SOCKET
31	2	473928	ROLL PIN, 3/16 X 1
32	2	910002	5/16UNC HEX NUT
33	2	920501	5/16 LOCK WASHER
34	1	470496	SPACER, BTM, DOOR HANDLE 470415
35	1	470497	SPACER, TOP, DOOR HANDLE 470415

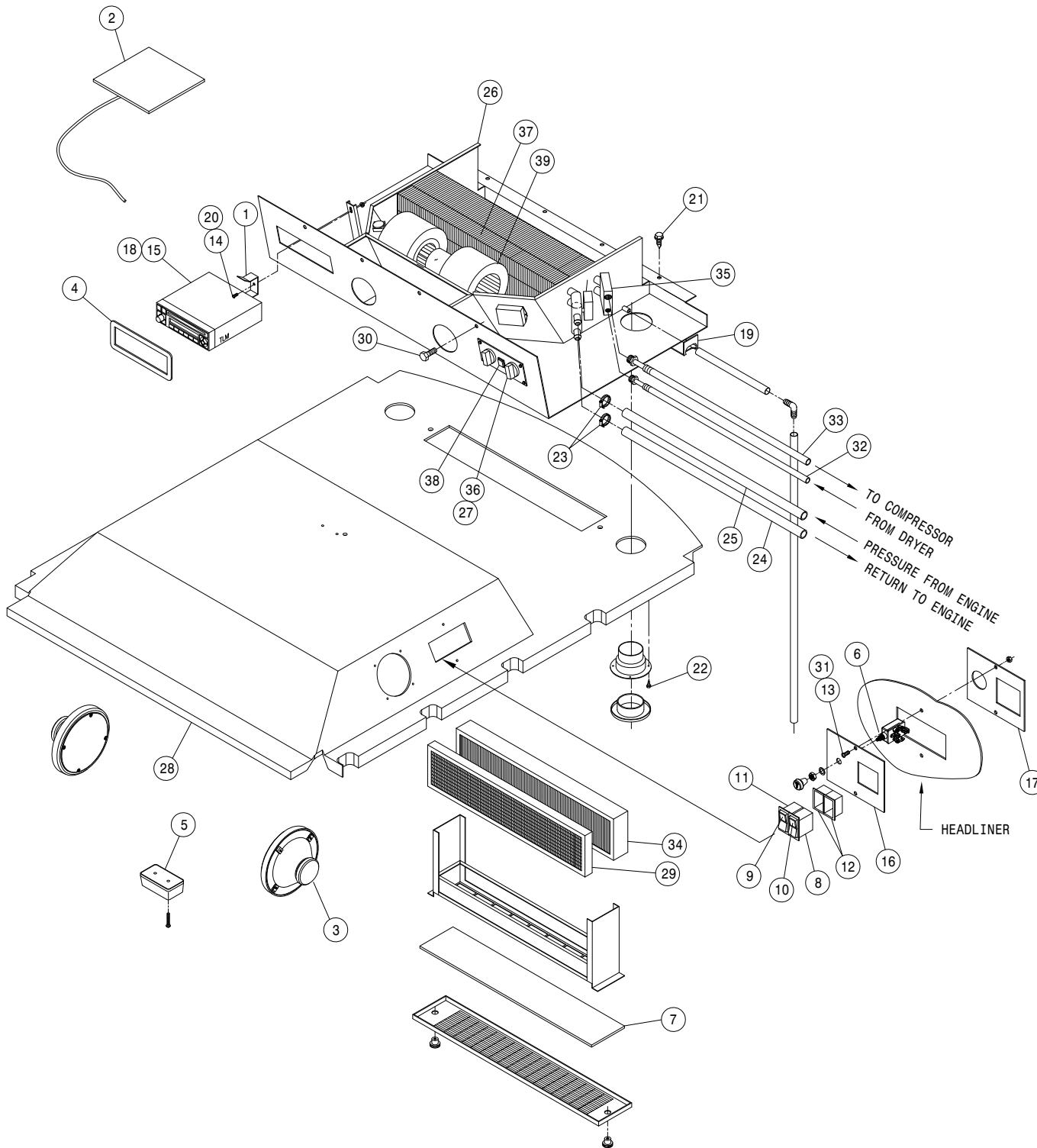

AIR CONDITIONER ASSEMBLY

DET.	QTY	PART NO.	DESCRIPTION
	1	291834	RADIO SUPPORT BRKT
	2	291924	ANTENNA AM/FM/WB HEADLINER MT
	3	291922	SPEAKERS,PAIR
	4	343331	RADIO BEZEL,CAB, BLK PLASIC 05
	5	291605	INTERIOR LIGHT W/SWITCH
	6	290074	LIGHT SWITCH
	7	657413	A/C FILTER,RECIRCULATION 30"
	8	291622	SWITCH,1P ON/OFF 511-003
	9	291630	LENS,WINDSHIELD WASHER,594-701
	10	291631	LENS, HAZARD 595-417
	11	291678	SWITCH, 511-115
	12	293246	END BEZEL, 594-802
	13	903710	10-32X5/8 PHIL PANHD MACH SCR
	14	903883	10-32 X 1/2 PHIL PAN MACH SCR
	15	291920	RADIO AM-FM WEATHERBAND CRW402
	16	342421	LIGHT SWITCH PANEL, 2100 98
	17	342633	LIGHT SWITCH PANEL KPR,2100 98
	18	291925	HARNES, RADIO CRW402 DTS 05
	19	342669	A/C DRAIN HOSE KEEPER
	20	470175	10-32 HEX FLANGE LOCK NUT
	21	472349	1/4 X 3/4 20THD-IN TEK TYPE
	22	473966	#6 X3/4 PHIL FLTHD SHT MTL SCR
	23	520055	HOSE CLAMP NO 12 STAINLESS
	24	601637	HOSE, 5/8 X 196 HEATER
	25	601638	HOSE, 5/8 X 254 HEATER
	26	657462	A/C-HTR BLOWER SYS, DTS10 05
	27	657415	A/C POTENTIOMETER ASSY
	28	658332	HEADLINER, DTS 10 05
	29	657425	A/C CHARCOAL AIR FILTER
	30	900128	3/8UNC X 3/4 HEX BOLT
	31	914027	10-32 HEX STOVER NUT
	32	657465	A/C HOSE ASSY, 5/16 X 202
	33	657466	A/C HOSE ASSY, 1/2 X 202
	34	657424	A/C PAPER AIR FILTER
	35	657411	A/C EXPANSION VALVE
	36	657409	A/C CONTROL KNOB
	37	657407	A/C HEATER COIL
	38	657410	A/C SWITCH, PUSH ON-OFF
	39	657448	A/C BLOWER ASSY, 12V KENWAY

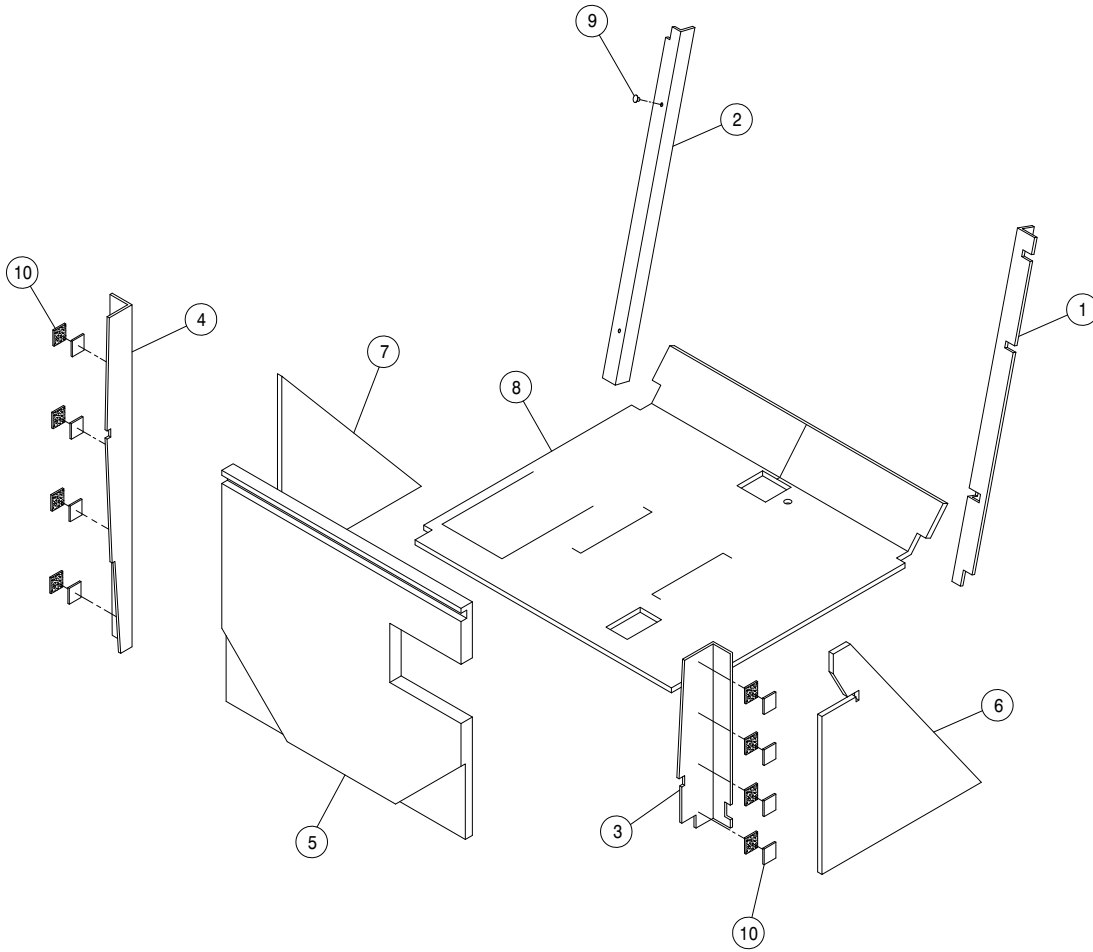

FOAM

DET. QTY PART NO. DESCRIPTION

1	1	658338	TORQ HUB MTG PLT REAR STR LEG
2	1	658320	POST COVER, LH FRONT 2100 98
3	1	658321	POST COVER, RH REAR 2100 98
4	1	658322	POST COVER, LH REAR 2100 98
5	1	658323	BACKPANEL, 2100 98
6	1	658324	SIDE PANEL, RH 2100 98
7	1	658325	SIDE PANEL, LH 2100 98
8	1	658326	FLOORMAT, 2100 98
9	2	470225	TRIM CLIP, 11/16 BLK NYL HEAD
10	8	471100	DUAL LOCK, 1.00 X 1.00 SJ3541

STEERING POST ASSEMBLY

DET.	QTY	PART NO.	DESCRIPTION
1	2	127502	NYLON FLANGE BRG
2	3	127503	NYLINER FLG BRG, .875 ID
3	1	291088	FLASHER / TURN SIGNAL SWITCH
4	1	342450	LWR STRG COLUMN WLD, 2100 98
5	1	342454	UPPER STRG COLUMN WLD, 2100 98
6	1	342461	STRG WHL MT WLD, 2100 98
7	1	342467	UPPER STRG COLUMN COVER, 2100 98
8	1	342468	CNTR STRG COLUMN COVER, 2100 98
9	1	342469	LWR STRG COLUMN SHLD
10	1	342470	STRG COLUMN PIVOT PIN, 2100 98
11	1	342471	STRG COL BRG HSNQ WLD, 2100 98
12	1	342474	UPPER STEERING SHAFT, 2100 98
13	1	470285	DOUBLE UNIVERSAL JOINT DRIVER
14	4	470346	GROMMET, .500ID .250GW, .812GD
15	4	920502	3/8 LOCK WASHER
16	1	342483	LWR STEERING SHAFT, 2100 98
17	1	342484	FOOT PEDAL PIV PIN WLD, 2100 98
18	1	342487	FOOT PEDAL WLD, 2100 98
19	1	342490	STRG PIVOT LOCK, 2100 98
20	1	342491	LWR AIR SHOCK PIVOT, 2100 98
21	2	342492	LWR AIR SHOCK PIV BUSH, 2100 98
22	2	390318	INDICATOR LIGHT, RED
23	10	470380	1/4-20 NUTSERT .027-.165 STL
24	1	470157	13/16-20UNEF HEX NUT STRG WHL
25	1	470252	GAS SPRING, 3.15 STROKE LOCKING
26	1	470257	ADJ HANDLE, 3/8-16 STUD, BLACK
27	1	470268	SPRING, EXTENSION, .50 X 1.75
28	2	470283	3/8UNC 1/2 SCKT SHLDR BOLT
29	2	473830	10MM-1.00 HEX JAM NUT
30	3	473928	ROLL PIN, 3/16 X 1
31	1	473936	ROLL PIN, 3/16 X 1 1/4
32	2	629525	RING, RETAINING, .50DIA SHAFT
33	2	629533	SNAP RING, 7/8 EXTRN
34	2	900065	5/16UNC X 1" HEX BOLT
35	1	900067	5/16UNC X 1 1/2 HEX BOLT
36	8	900128	3/8UNC X 3/4 HEX BOLT
37	10	903708	1/4UNC X 1/2PHIL PANHD MACH SCR
38	3	914002	5/16UNC HEX STOVER NUT
39	4	914004	3/8UNC HEX STOVER NUT
40	1	920002	3/8 SAE FLAT WASHER
41	1	920007	7/8 SAE FLAT WASHER
42	1	749294	STEERING WHEEL, VIP 14"
43	1	749295	STRG WHL CAP W/HAGIE EMBLEM
44	4	900267	1/2UNC X 2" HEX BOLT
45	4	914008	1/2UNC HEX STOVER NUT
46	4	920004	1/2 SAE FLAT WASHER
47	1	343211	STEERING MTR PLT, 284XP/2100 02
48	4	618109	9/16MJIC-3/4MOR ADPTR
49	1	749318	STRG MTR, 7.3CID, NON-LOAD 1031
50	2	483031	1 3/8 X 7/8 X 18GA MACH WASHER
51	1	470342	SNAP PLUG, BLK NYL, .375 DIA
52	4	470345	1/2UNC HEX SMTH FLNG LOCK NUT
53	4	470479	5" SAFETY LOCK WIRE, 304SS .051D

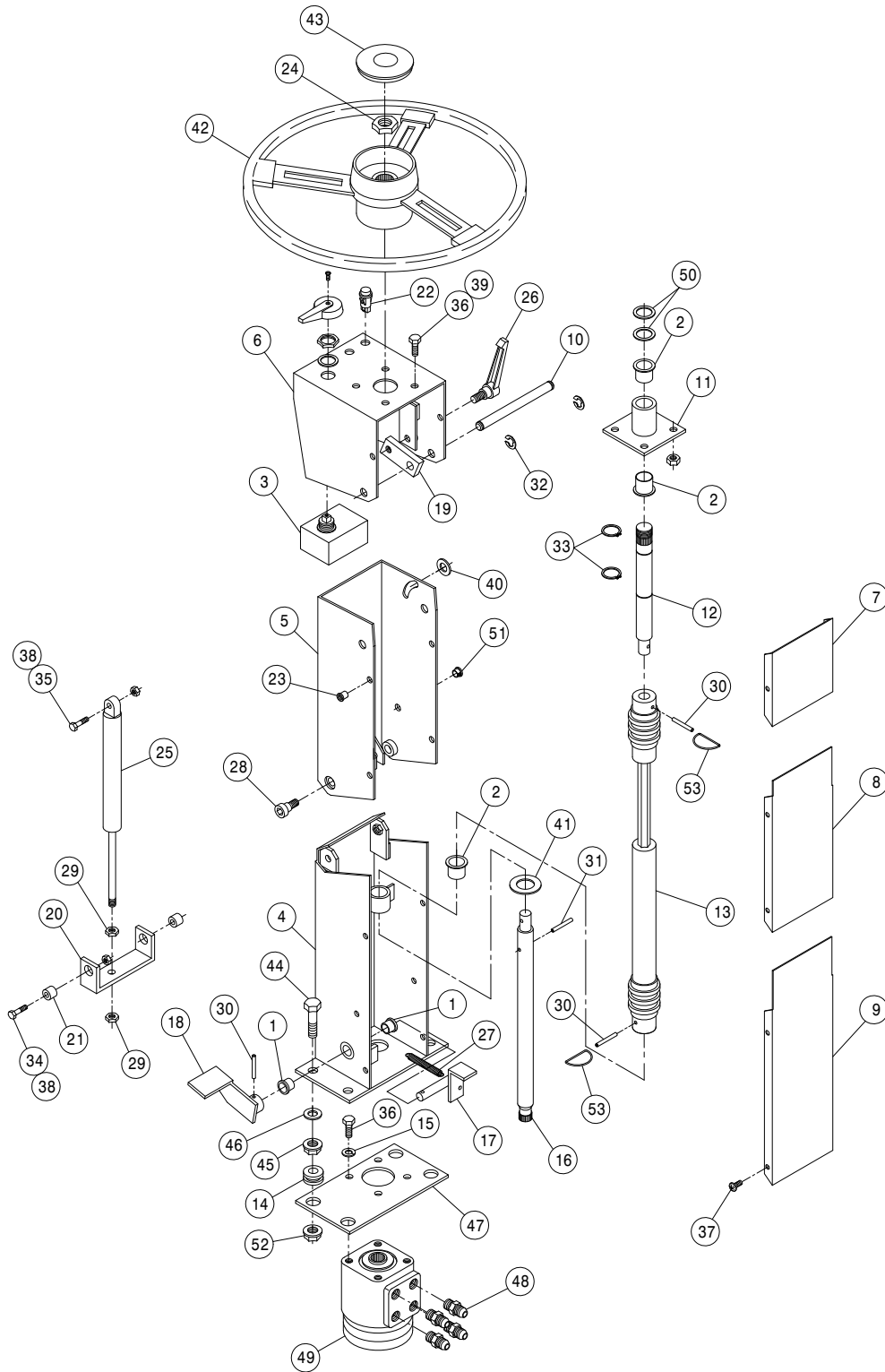

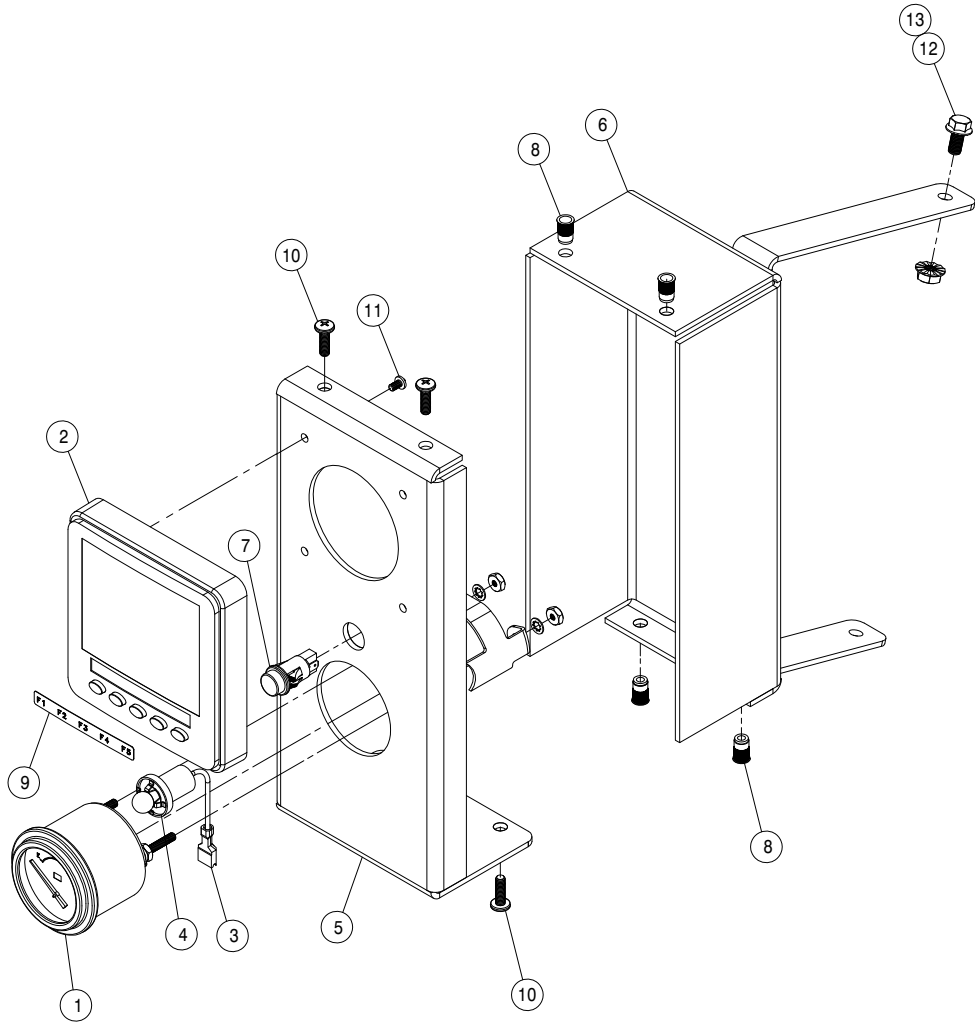

CANTRAK ASSEMBLY

DET. QTY PART NO. DESCRIPTION

1	1	290401	FUEL GAUGE FOR 2.125 DIA HOLE
2	1	291349	CANTRAK 2600 DISPLAY
3	1	291571	TYCO,FASTON,.250(16-14GA),FEM
4	1	291612	LIGHT KIT FOR 2" GAUGE
5	1	343088	FRT CANTRAK MNT, DTS10 '10
6	1	343091	CANTRAK MNT WLD, DTS10 '10
7	1	390318	INDICATOR LIGHT, RED
8	4	470384	10-32 NUTSERT .020-.130 STL
9	1	650270	DECAL,CANTRAK FUNCTION KEY
10	4	903710	10-32X5/8 PHIL PANHD MACH SCR
11	4	903804	6-32 X 1/4 PHIL PAN MACH SCR
12	2	470122	1/4UNC X 1/2 FLANGE HEX BOLT
13	2	470121	1/4UNC HEX FLANGE LOCK NUT

CONSOLE COVER ASSEMBLY

DET. QTY PART NO. DESCRIPTION

1	4	291627	SWITCH,2P(ON)OFF(ON)	511-058
2	5	291628	LENS, GREEN	596-650
3	1	291671	SWITCH,2P OFF/ONA/ONAB	511-138
4	2	293247	CENTER BEZEL,	594-801
5	1	343252	CONSOLE TOP WLD,	2101 03
6	1	342509	CONSOLE LID ASSY,	2100 98
7	4	473002	#6 X1/2 PHIL FLTHD SHT MTL SCR	
8	4	903710	10-32X5/8 PHIL PANHD MACH SCR	
9	2	293246	END BEZEL,	594-802

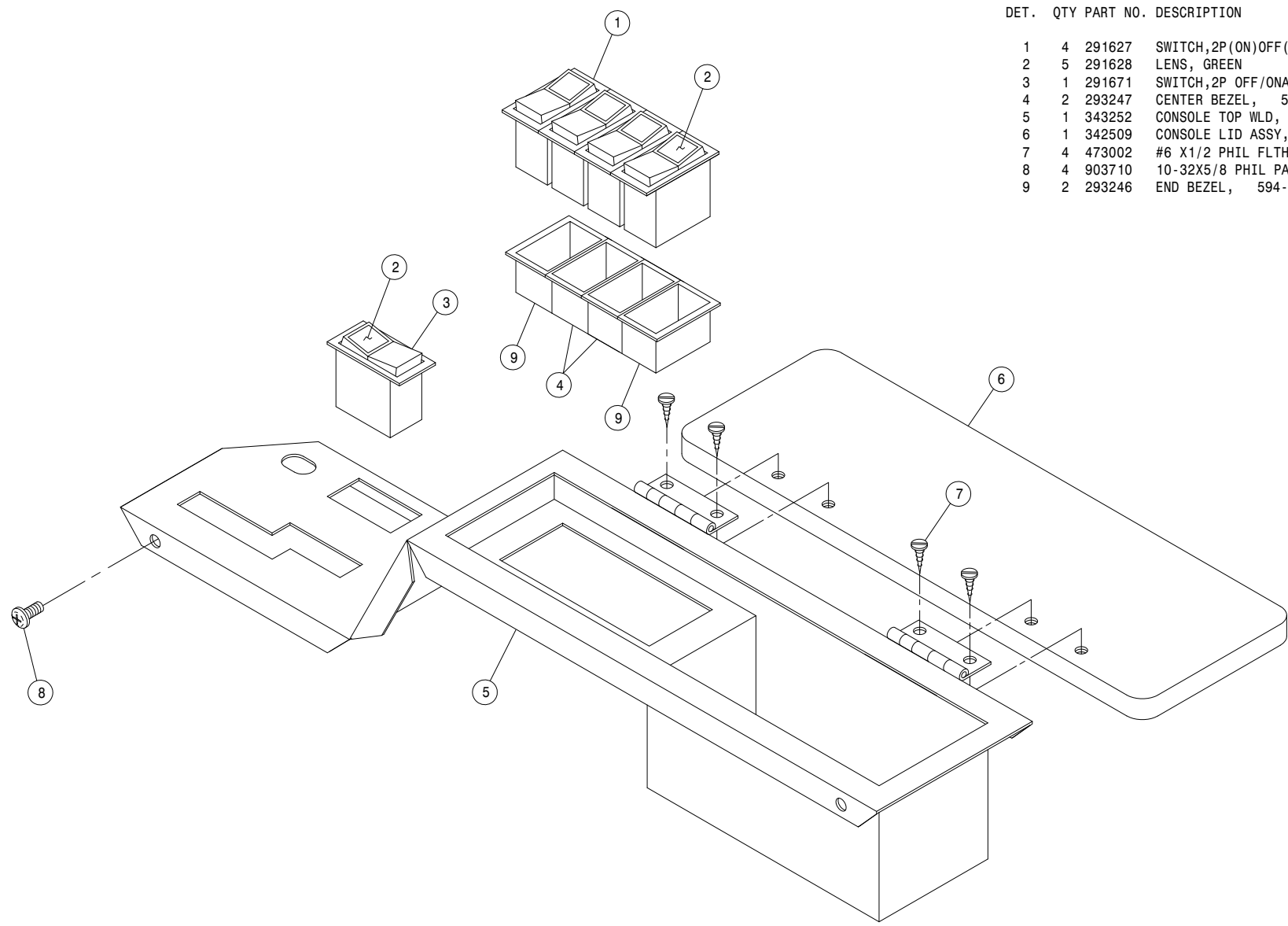

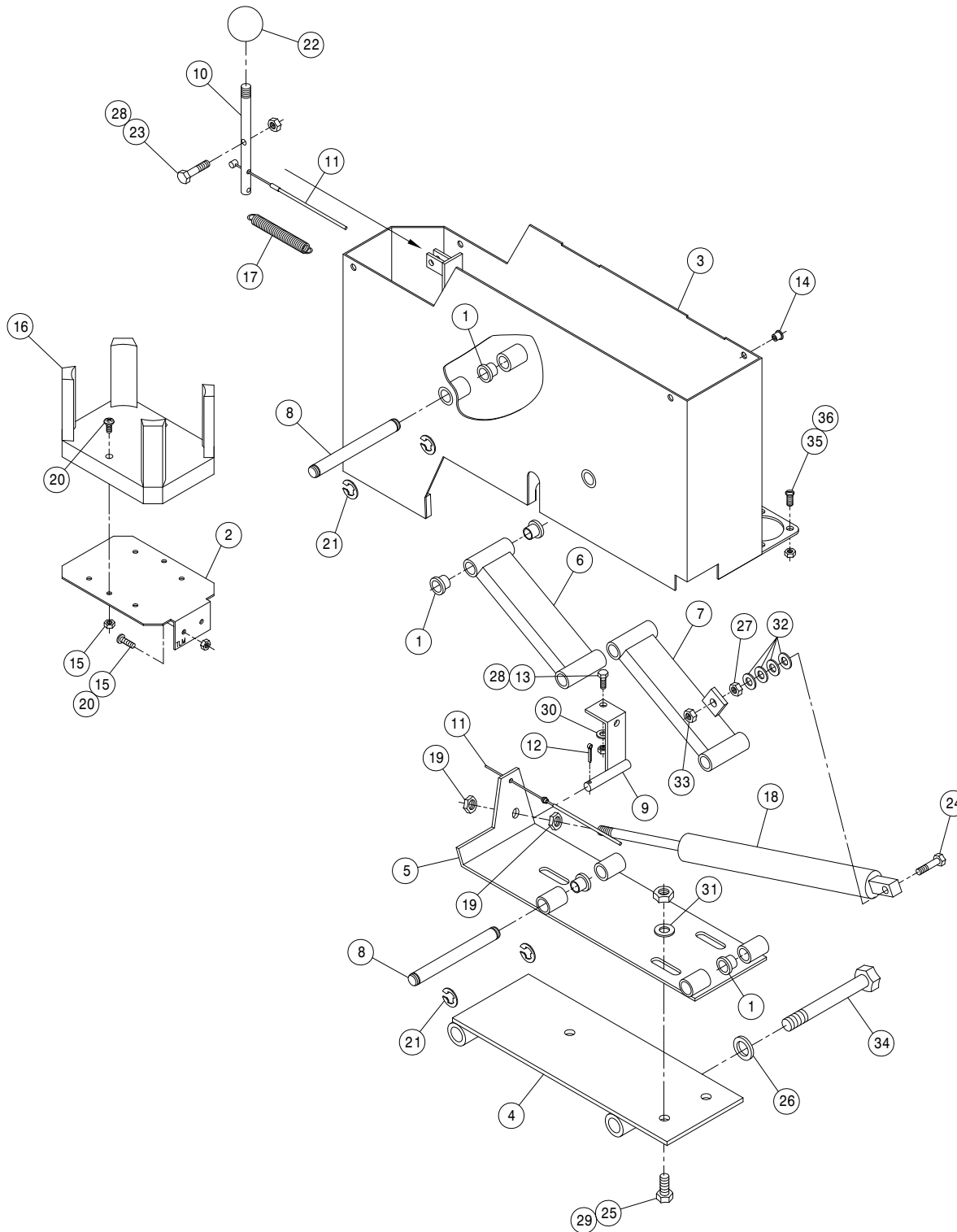

CONSOLE ASSEMBLY

DET. QTY PART NO. DESCRIPTION

1	16	127504	NYLINER FLG BRG, .500 ID	
2	1	342216	DRINK HOLDER MT BRKT	94
3	1	343254	CONSOLE WLD, 2101	03
4	1	342510	CONSOLE SEAT MT WLD, 2100	98
5	1	342513	LWR CONSOLE MTG PLT WLD2100	98
6	1	342516	FRT CONSOLE PIVOT BRKT WLD	98
7	1	342519	REAR CONSOLE PIVOT BRKT WLD	98
8	4	342522	CONSOLE PIN, 2100	98
9	1	342523	AIR SHOCK RELEASE WLD, 2100	98
10	1	342526	ADJ HANDLE, 2100	98
11	1	342527	CONSOLE ADJ CABLE ASSY,2100	98
12	1	470006	COTTER PIN 1/8 X 1	
13	1	470118	1/4UNC X 3/4 FLANGE HEX BOLT	
14	4	470384	10-32 NUTSERT .020-.130	STL
15	2	470175	10-32 HEX FLANGE LOCK NUT	
16	1	470214	SPILLMASTER DRINK HOLDER	
17	1	470248	SPRING,EXPANSION .438 X 3.00	
18	1	470251	GAS SPRING, LOCKING 0250N	
19	2	473830	10MM-1.00 HEX JAM NUT	
20	4	903710	10-32X5/8 PHIL PANHD MACH SCR	
21	8	629525	RING, RETAINING, .50DIA SHAFT	
22	1	659291	KNOB,1" RND,BLK, 3/8-16	
23	1	900003	1/4UNC X 1" HEX BOLT	
24	1	900067	5/16UNC X 1 1/2 HEX BOLT	
25	3	900129	3/8UNC X 1" SERR FLANGE BOLT	
26	2	920505	5/8 LOCK WASHER	
27	1	910002	5/16UNC HEX NUT	
28	2	914000	1/4UNC HEX STOVER NUT	
29	3	914004	3/8UNC HEX STOVER NUT	
30	1	920000	1/4 SAE FLAT WASHER	
31	3	920002	3/8 SAE FLAT WASHER	
32	4	920001	5/16 SAE FLAT WASHER	
33	1	914002	5/16UNC HEX STOVER NUT	
34	2	900345	5/8UNC X 5 1/2 HEX BOLT	
35	4	903812	6-32 X 1/2 PHIL PAN MACH SCR	
36	4	910022	6-32 HEX NUT	

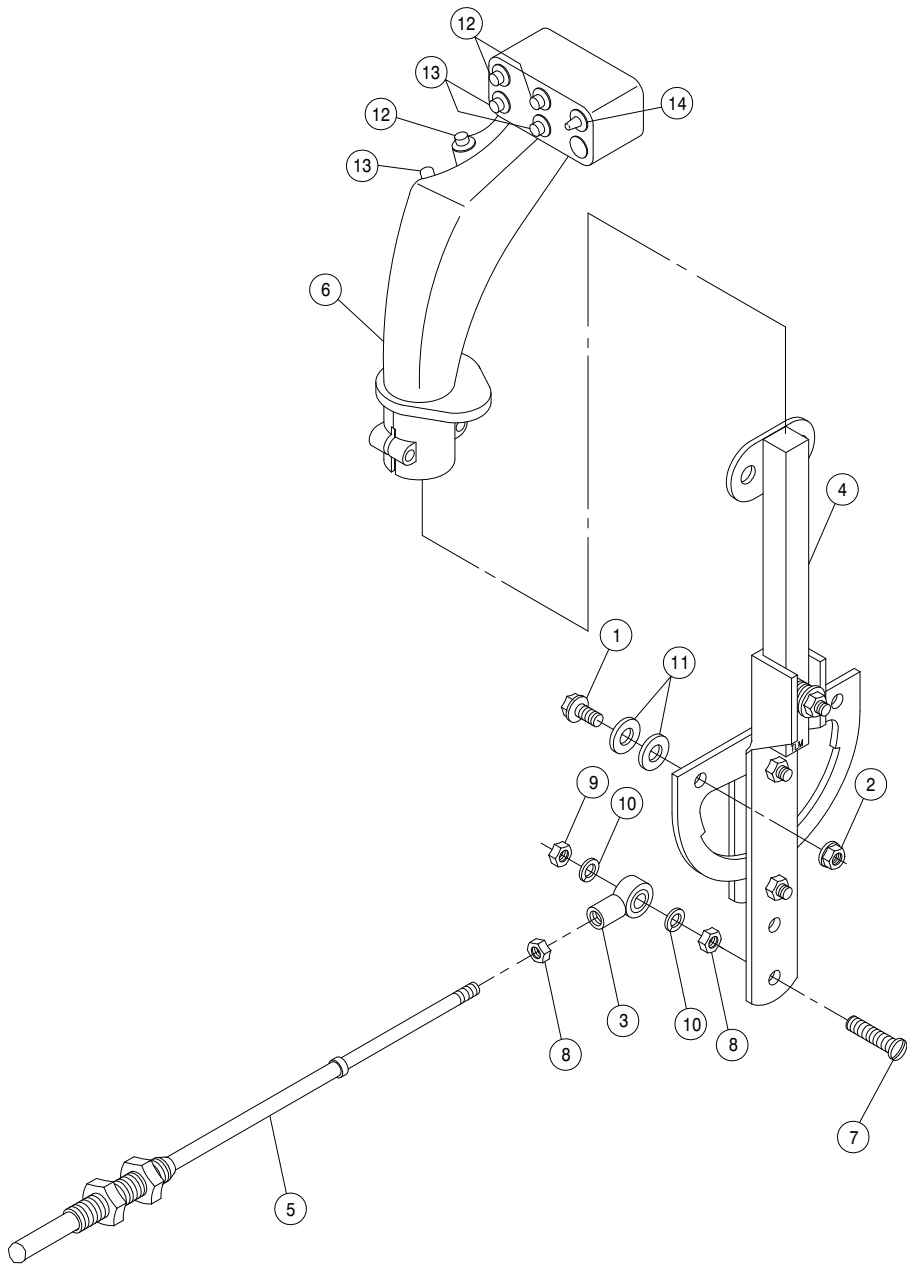

HYDROSTATIC LEVER ASSEMBLY

DET.	QTY	PART NO.	DESCRIPTION
	1	2 470118	1/4UNC X 3/4 FLANGE HEX BOLT
	2	2 470121	1/4UNC HEX FLANGE LOCK NUT
	3	1 473921	BALL JOINT NO 10-32 THD
	4	1 342528	HYDST CTRL LEVER ASSY, 2100 98
	5	1 785066	CTRL CABLE 10-32 4IN X 129 IN
	6	1 785086	FASSE CTRL HANDLE, C12L4T28
	7	1 903893	10-32 X 1" PHIL PAN MACH SCR
	8	2 910027	10-32 HEX NUT
	9	1 914027	10-32 HEX STOVER NUT
	10	2 920510	#10 LOCK WASHER
	11	4 920000	1/4 SAE FLAT WASHER
	12	3 291884	SWITCH,PB 3TRM MOM O, GRAY
	13	3 291883	SWITCH,PB 3TRM MOM O, RED
	14	1 291653	SWITCH, TOG SPDT 3POS STAT

SWITCH PANEL ASSEMBLY

DET.	QTY	PART NO.	DESCRIPTION	
1	3	291622	SWITCH,1P ON/OFF	511-003
2	1	291623	SWITCH,2P ON/OFF	511-015
3	7	291625	SWITCH,2P ON/ON	511-108
4	5	291627	SWITCH,2P(ON)OFF(OFF)	511-058
5	17	291628	LENS, GREEN	596-650
6	1	291638	INDICATOR LIGHT, GREEN	
7	1	291647	DUAL BINDING POSTS	
8	2	629768	CAPPLUGS CAP,.093 X .750 VINYL	
9	1	291775	SWITCH, LOCK OFF/ON	511-172
10	3	291776	BLANK COVER, 596-273	
11	8	293246	END BEZEL, 594-802	
12	13	293247	CENTER BEZEL, 594-801	
13	1	321021	IGN SWITCH, NON-SEALED	
14	1	342428	MONITOR BRKT, 2100	98
15	1	342532	BOOM SWITCH PANEL, 2100	98
16	1	343246	SWITCH PANEL, 2101	03
17	1	343256	SWITCH HOUSING WLD, 2101	03
18	1	390318	INDICATOR LIGHT, RED	
19	1	470070	GROMMET, .375ID .062GW .500GD	
20	14	470380	1/4-20 NUTSERT .027-.165 STL	
21	2	470118	1/4UNC X 3/4 FLANGE HEX BOLT	
22	4	470122	1/4UNC X 1/2 FLANGE HEX BOLT	
23	4	470339	SNAP PLUG, BLK NYL, .250 DIA	
24	1	690618	CONSOLE, RAVEN 460 W/GPS PORT	
25	2	900000	1/4UNC X 1/2 HEX BOLT	
26	10	903708	1/4UNC X1/2PHIL PANHD MACH SCR	
27	3	914000	1/4UNC HEX STOVER NUT	
28	1	342425	SWITCH HSG SUPP WLD, 2100	98
29	1	291626	SWITCH,2P ON/OFF/OFF	511-053
30	1	900005	1/4UNC X 1 1/2 HEX BOLT	
31	2	470121	1/4UNC HEX FLANGE LOCK NUT	
32	1	291005	LENS, RED	596-615

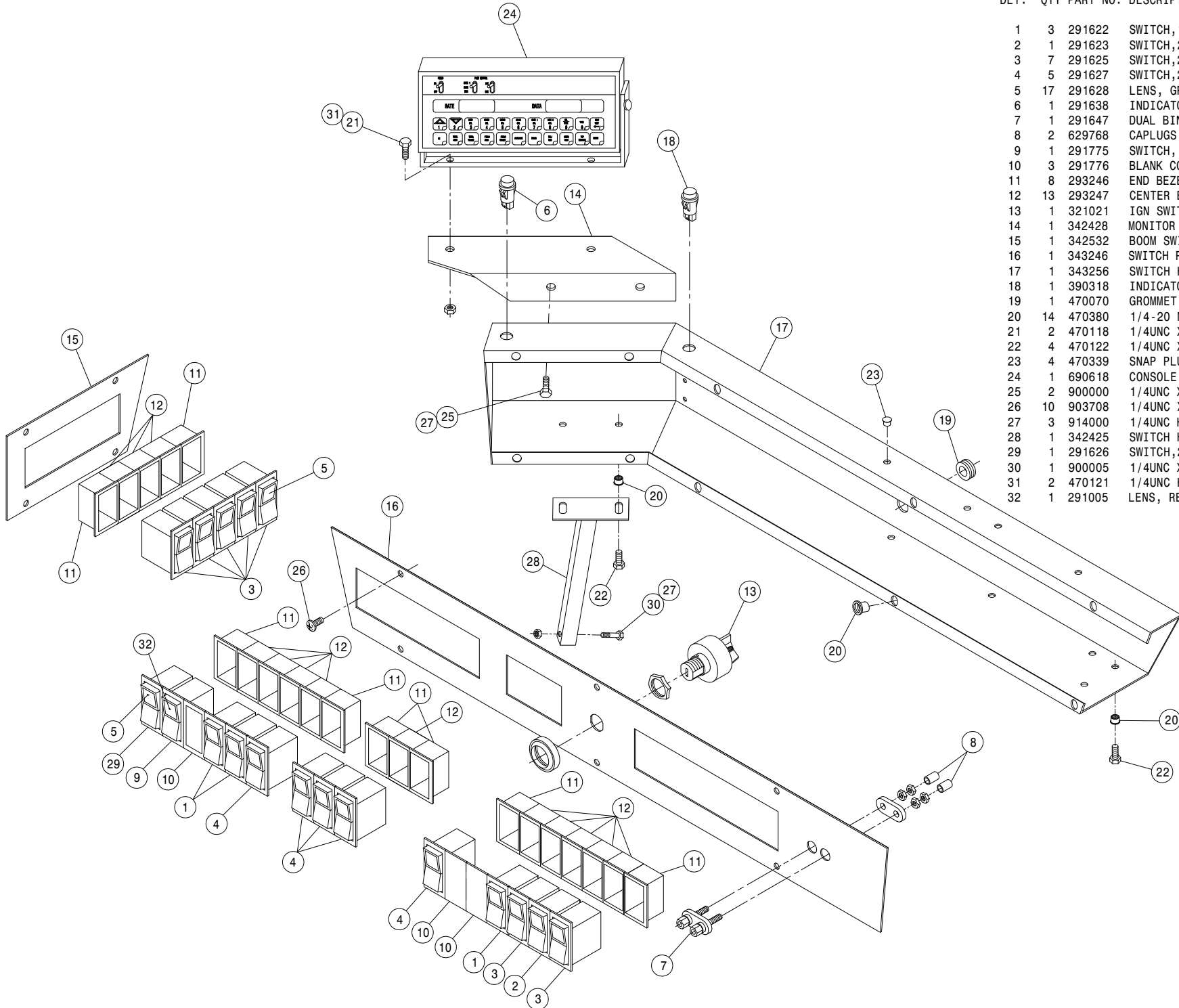

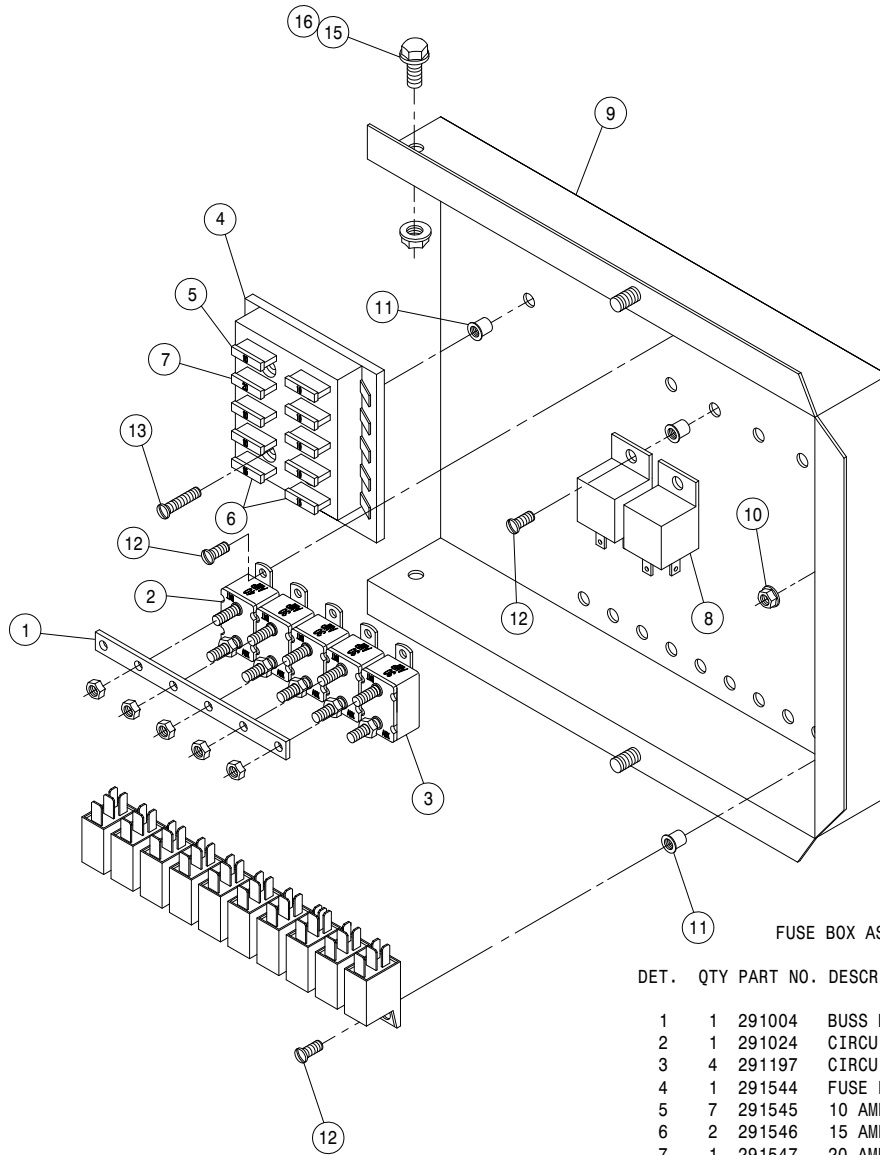
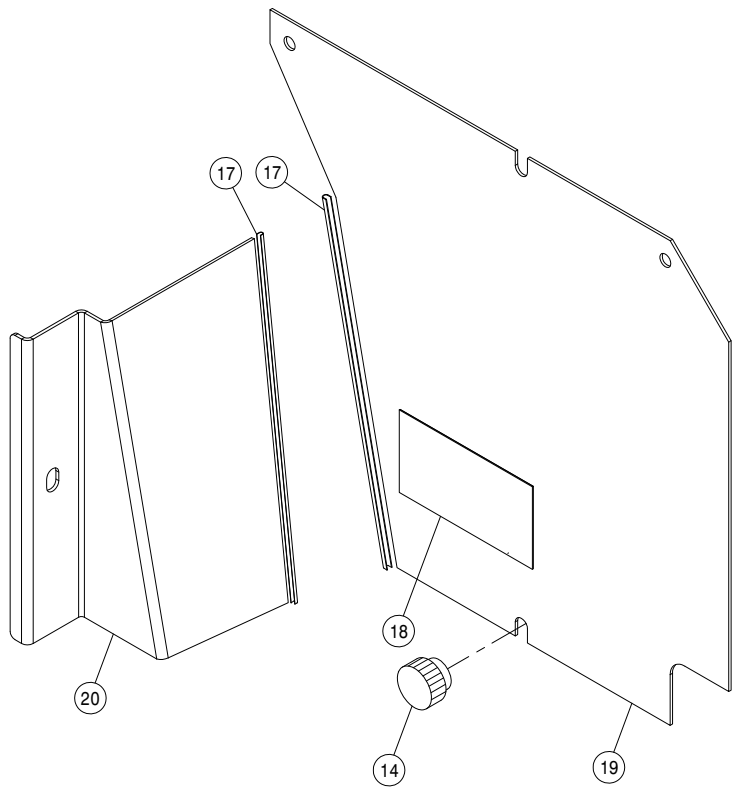

FUSE BOX ASSEMBLY

DET.	QTY	PART NO.	DESCRIPTION
1	1	291004	BUSS BAR,6 GANG CIRCUIT BREAKR
2	1	291024	CIRCUIT BREAKER,40AMP,INLINEMT
3	4	291197	CIRCUIT BREAKER,30AMP,INLINEMT
4	1	291544	FUSE PANEL,10 CIRCUIT,BLADE TP
5	7	291545	10 AMP FUSE,ATC,1/4"BLADE
6	2	291546	15 AMP FUSE,LED 1/4"BLADE,ATC
7	1	291547	20 AMP FUSE,LED 1/4"BLADE,ATC
8	2	291640	RELAY, 12V 20/30AMP BOSCH
9	1	343242	FUSE BOX WLD, 2101/2101C 03
10	1	470121	1/4UNC HEX FLANGE LOCK NUT
11	22	470384	10-32 NUTSERT .020-.130 STL
12	17	903884	10-32X3/8 PHIL PANHD MACH SCR
13	2	903893	10-32 X 1" PHIL PAN MACH SCR
14	3	470284	KNOB,.88 KNRLD,BLK,1/4-20
15	2	900000	1/4UNC X 1/2 HEX BOLT
16	2	914000	1/4UNC HEX STOVER NUT
17	2	193011	EDGE GUARD, BLK
18	1	650292	DECAL,ADDITIONAL FUSES, DTS10
19	1	343008	FUSE BOX COVER DTS10'12
20	1	343007	HARNESS COVER DTS10'12

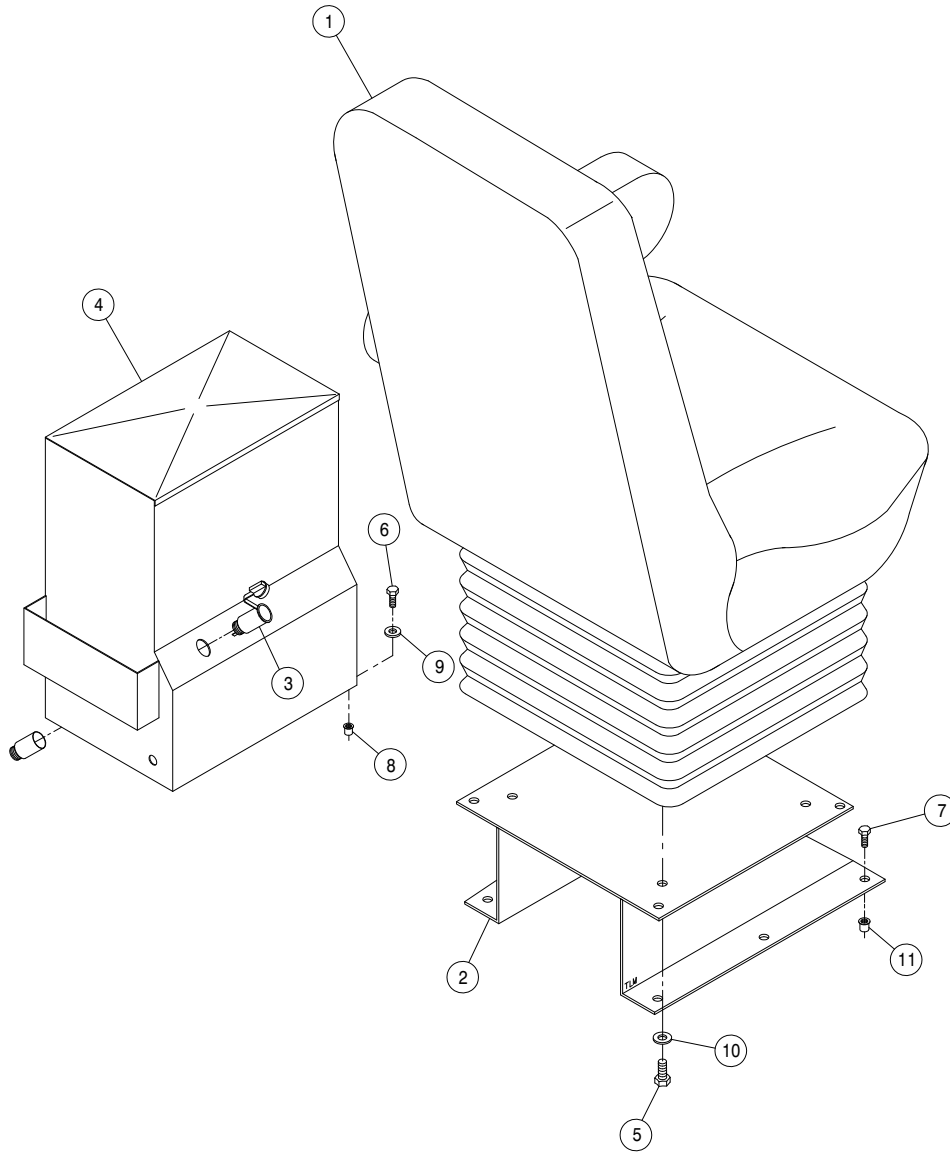

SEAT AND CONSOLE ASSEMBLY

DET. QTY PART NO. DESCRIPTION

1	1	330034	SEAT & AIR RIDE ASSY, STS	05
2	1	342090	SEAT MT WELD, 254/284	95
3	1	291648	POWER POINT RECEPTACLE	
4	1	342432	LH CONSOLE WLD, 2100	98
5	4	473827	8MM-1.25 X 20MM HEX BOLT	
6	4	900002	1/4UNC X 3/4 HEX BOLT	
7	4	900129	3/8UNC X 1" SERR FLANGE BOLT	
8	4	470380	1/4-20 NUTSERT .027-.165	STL
9	4	920000	1/4 SAE FLAT WASHER	
10	4	920501	5/16 LOCK WASHER	
11	6	470382	3/8-16 NUTSERT .027-.150	STL

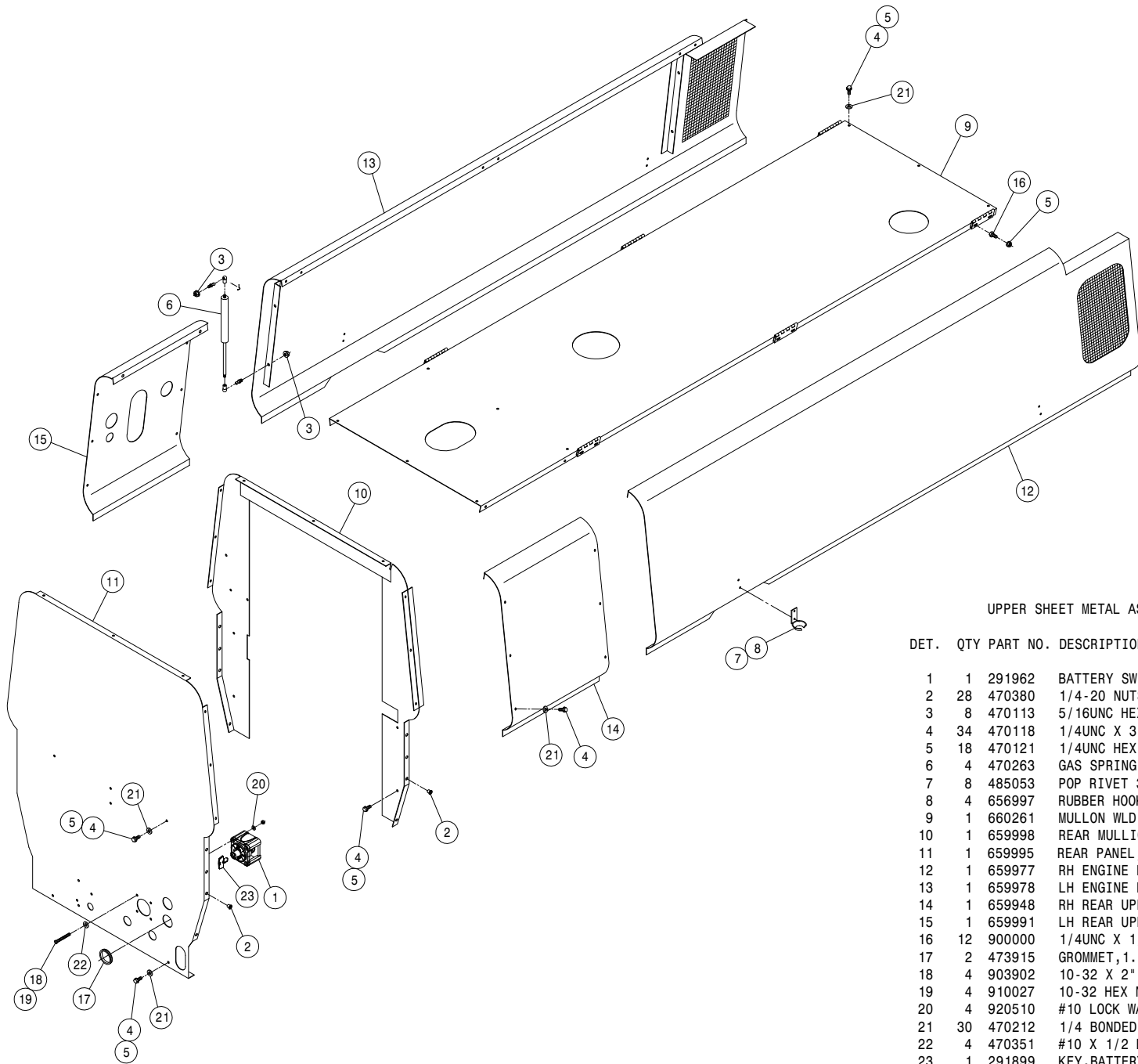

UPPER SHEET METAL ASSEMBLY

DET.	QTY	PART NO.	DESCRIPTION
	1	291962	BATTERY SWITCH,ON/OFF(KEY)6005
	28	470380	1/4-20 NUTSERT .027-.165 STL
	8	470113	5/16UNC HEX FLANGE LOCK NUT
	34	470118	1/4UNC X 3/4 FLANGE HEX BOLT
	18	470121	1/4UNC HEX FLANGE LOCK NUT
	4	470263	GAS SPRING, 4016 8.00 STROKE
	8	485053	POP RIVET 3/16 X 3/8
	4	656997	RUBBER HOOK BRKT
	1	660261	MULLON WLD, CUMM, DTS10, '10
	1	659998	REAR MULLION SUPP WLD,DTS10'10
	1	659995	REAR PANEL, 2101 03
	1	659977	RH ENGINE HOOD WLD, 2101 03
	1	659978	LH ENGINE HOOD WLD, 2101 03
	1	659948	RH REAR UPPER PANEL, 2100 98
	1	659991	LH REAR UPPER PANEL, 2101 03
	12	900000	1/4UNC X 1/2 HEX BOLT
	2	473915	GROMMET,1.500ID .062GW 1.750GD
	4	903902	10-32 X 2" PHIL PAN MACH SCR
	4	910027	10-32 HEX NUT
	4	920510	#10 LOCK WASHER
	30	470212	1/4 BONDED SEALING WASH, SS
	4	470351	#10 X 1/2 BONDED SEALING WASH
	1	291899	KEY,BATTERY SWITCH 291870

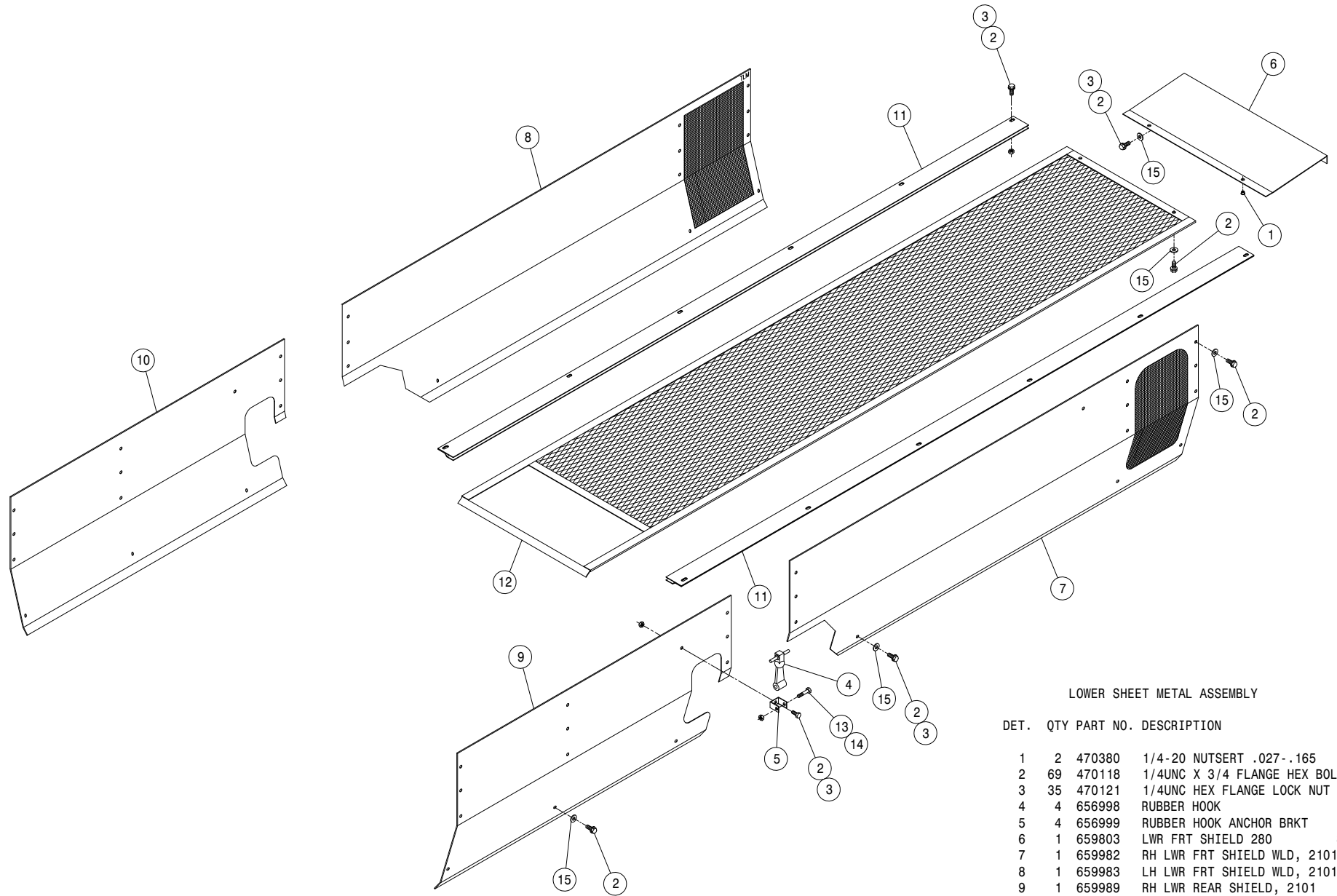

LOWER SHEET METAL ASSEMBLY

DET. QTY PART NO. DESCRIPTION

1	2	470380	1/4-20 NUTSERT .027-.165 STL
2	69	470118	1/4UNC X 3/4 FLANGE HEX BOLT
3	35	470121	1/4UNC HEX FLANGE LOCK NUT
4	4	656998	RUBBER HOOK
5	4	656999	RUBBER HOOK ANCHOR BRKT
6	1	659803	LWR FRT SHIELD 280 89
7	1	659982	RH LWR FRT SHIELD WLD, 2101 03
8	1	659983	LH LWR FRT SHIELD WLD, 2101 03
9	1	659989	RH LWR REAR SHIELD, 2101 03
10	1	659990	LH LWR REAR SHIELD, 2101 03
11	2	659957	LWR SCRN SLIDE WLD, 2100 98
12	1	659960	LWR SCRN WLD, 2100 98
13	4	900006	1/4UNC X 1 3/4 HEX BOLT
14	4	470089	1/4UNC HEX NYLOC NUT, 316 SS
15	53	470212	1/4 BONDED SEALING WASH, SS

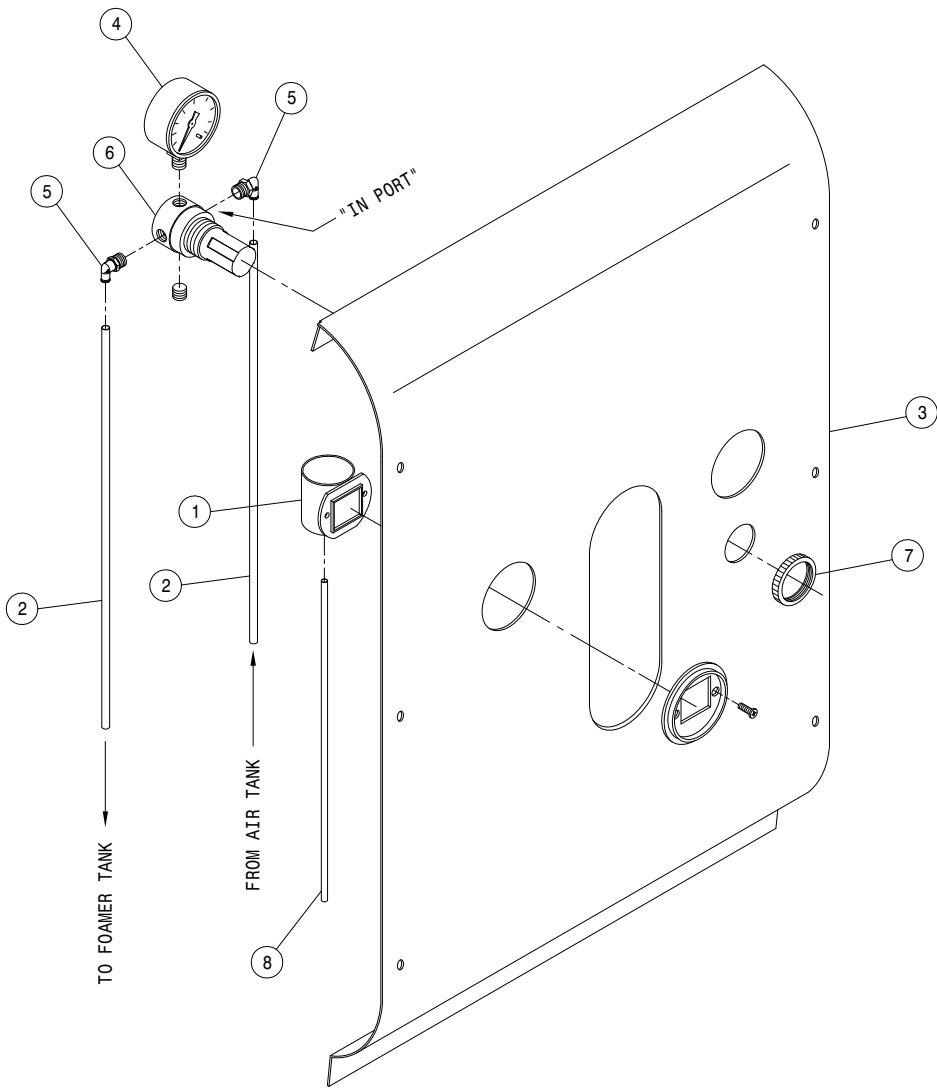

FOAMER AIR REGULATOR ASSEMBLY

DET. QTY PART NO. DESCRIPTION

1	1	314901	FILTER MINDER AIR RESTRICT GA
2	2	601790	HOSE, 1/4 X 79 AIR
3	1	659991	LH REAR UPPER PANEL, 2101 03
4	1	701310	AIR PRESS GAUGE, 1/8" BOT
5	2	711040	1/4MNPT-90-1/4 NYL TUBE LBO
6	1	711019	1/4"MNPT AIR REGULATOR
7	1	711021	1 1/4-18 NUT,AIR REGULATOR MT
8	1	195913	HOSE 7/64" WINDSHIELD WASHER

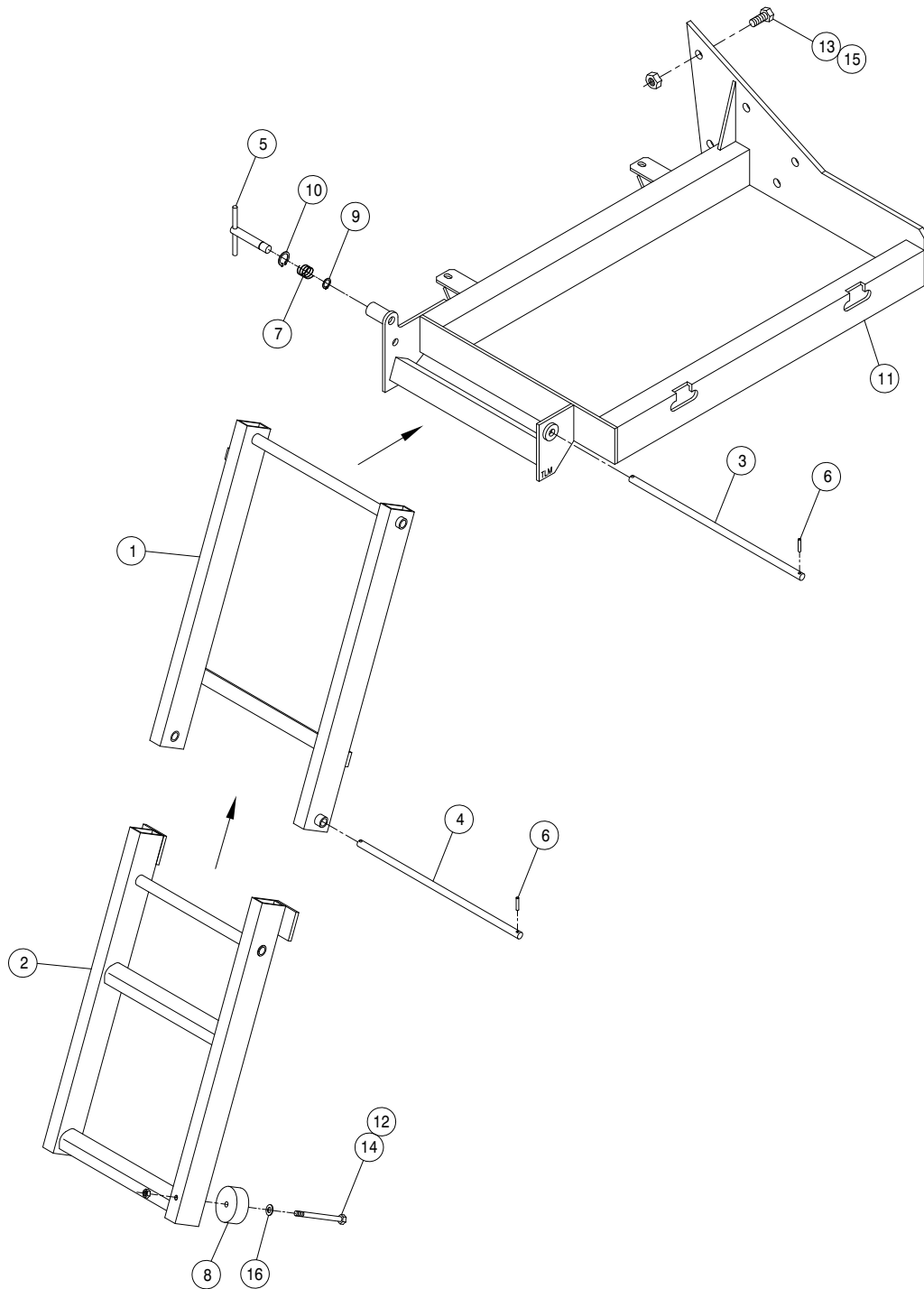

RIGHT FOLDING LADDER ASSEMBLY

DET. QTY PART NO. DESCRIPTION

1	1	342583	FOLD LDDR UPR SECT WLD,2100 98
2	1	342589	FOLD LDDR LWR SECT WLD,2100 98
3	1	342594	FOLD LADDER UPR PIVOT PIN 98
4	1	342595	FOLD LADDER LWR PIVOT PIN 98
5	1	342596	FOLD LDDR LOCK PIN WLD,2100 98
6	4	473928	ROLL PIN, 3/16 X 1
7	1	482131	3/4 X 1 3/4 COMPRSN SPRING
8	1	470098	RUBBER BUMPER 2.500D X .38ID
9	1	629534	SNAP RING, 9/16 EXTERNAL
10	1	629535	SNAP RING, 3/4 INTERNAL
11	1	760278	RH FUEL TANK MT WLD, 2101 03
12	1	900072	5/16UNC X 3" HEX BOLT
13	6	900334	5/8UNC X 1 3/4 HEX BOLT
14	1	910002	5/16UNC HEX NUT
15	6	914010	5/8UNC HEX STOVER NUT
16	1	920001	5/16 SAE FLAT WASHER

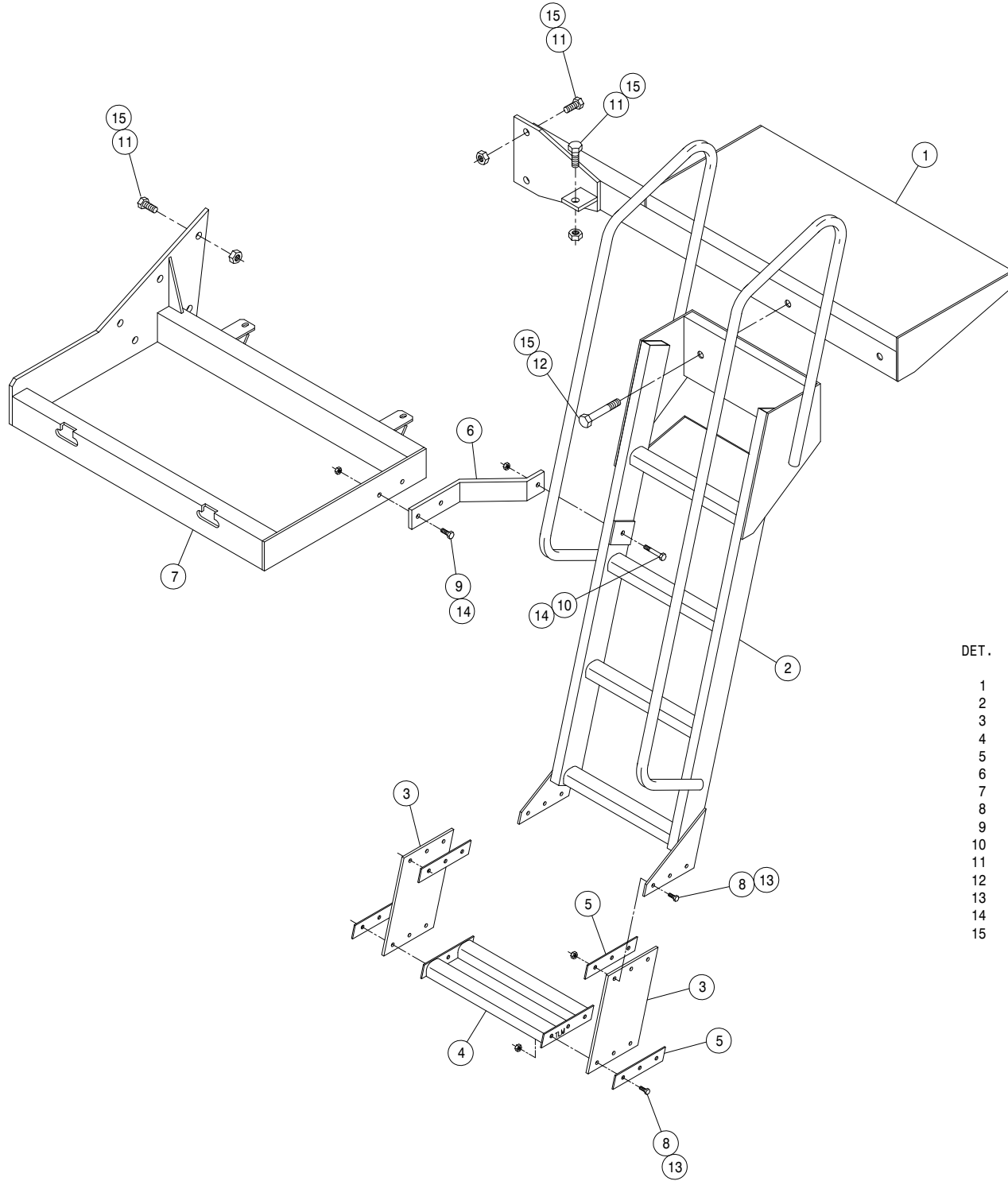

LEFT LADDER ASSEMBLY

DET. QTY PART NO. DESCRIPTION

1	1	342599	LH LADDER MT WLD, 2100	98
2	1	342605	LH LADDER WLD, 2100	98
3	2	342614	LADDER SIDE, LWR STEP, 2100	98
4	1	342615	LADDER STEP WLD, 2100	98
5	4	342616	LWR STEP SIDE KEEPER, 2100	98
6	1	342618	LH LADDER SUPP BRKT, 2100	98
7	1	760279	LH FUEL TANK MT WLD, 2101	03
8	12	900065	5/16UNC X 1" HEX BOLT	
9	2	900130	3/8UNC X 1 1/4 SER FLANGE BOLT	
10	1	900133	3/8UNC X 2" SERR FLANGE BOLT	
11	9	900334	5/8UNC X 1 3/4 HEX BOLT	
12	2	900829	5/8UNC X 4" HEX BOLT GR8	
13	12	914002	5/16UNC HEX STOVER NUT	
14	3	914004	3/8UNC HEX STOVER NUT	
15	11	914010	5/8UNC HEX STOVER NUT	

FUEL TANK ASSEMBLY

DET. QTY PART NO. DESCRIPTION

1	2	291428	FUEL SENDER 19 IN.
2	10	473902	#8 X 1/2 PHIL PAN HD MTL SCR
3	2	501102	1/4 PIPE PLUG
4	8	501451	BLK PIPE EL 90DEG .25NPT
5	4	501602	BLK PIPE NIPPLE .25NPT-1.50
6	2	760271	FUEL TANK WLD, 2101
7	1	760247	FUEL TANK SERV, 2101
8	2	783303	1/4 NPT X 5/16 HOSE BARB, BRS
9	2	783304	1/4 NPT X 3/8 HOSE BARB, BRS
10	4	760276	FUEL TANK BAND WLD, 2101
11	4	914004	3/8UNC HEX STOVER NUT
12	10	520120	HOSE CLAMP NO 4 STAINLESS
13	1	601731	HOSE, 5/16 X 32 FUEL LINE
14	1	601740	HOSE, 3/8 X 123 FUEL LINE
15	2	291464	GSKT FUEL SENDER, FOR 291428
16	1	601545	HOSE, 5/16 X 108 FUEL LINE
17	1	601739	HOSE, 3/8 X 115 FUEL LINE
18	1	601551	HOSE, 3/8 X 38 FUEL LINE
19	1	610529	FUEL SELECTOR VALVE W/RETURN
20	4	470121	1/4UNC HEX FLANGE LOCK NUT
21	2	900064	5/16UNC X 3/4 HEX BOLT
22	2	761200	GAS CAP

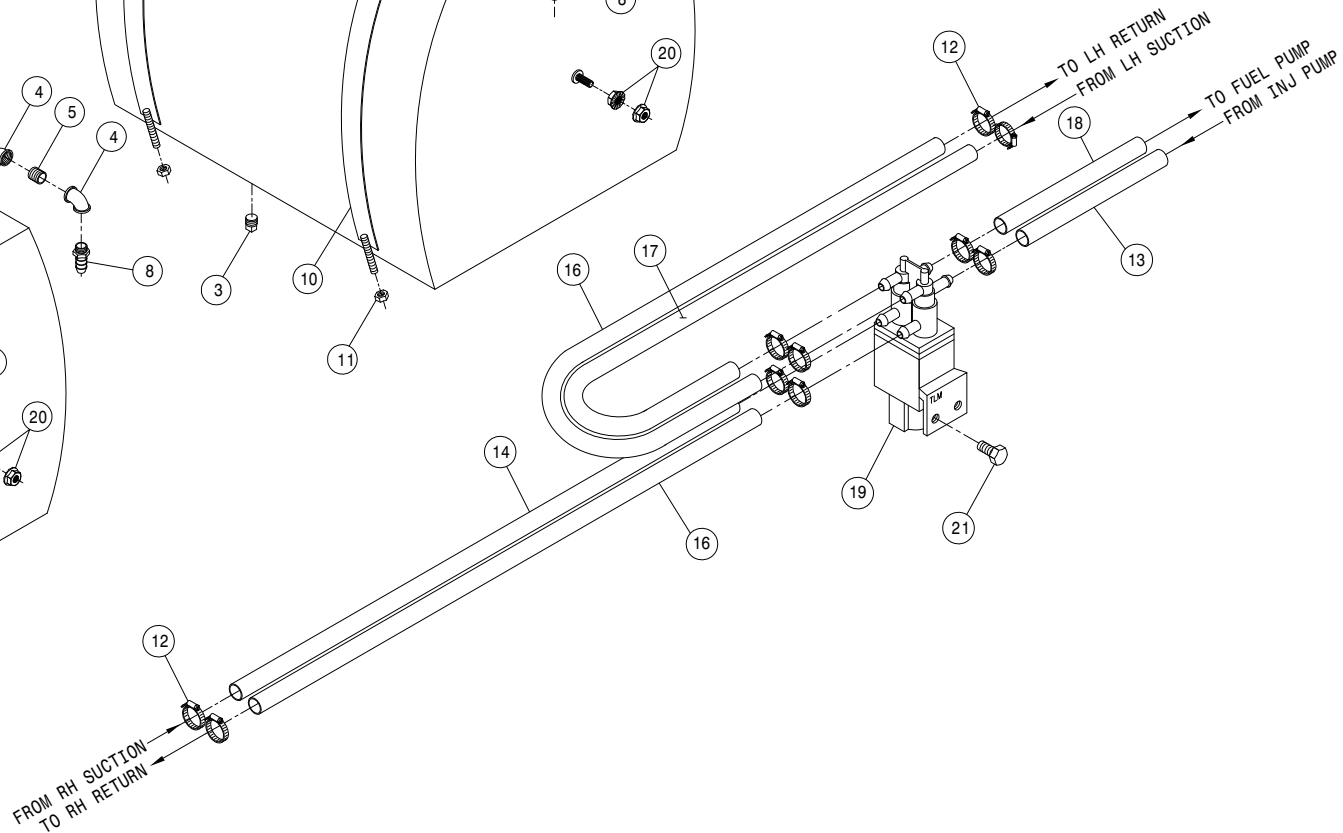
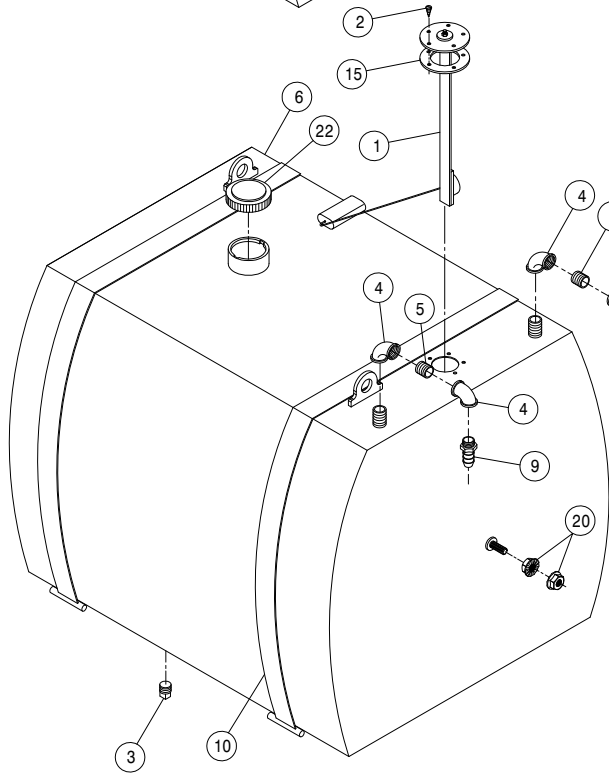
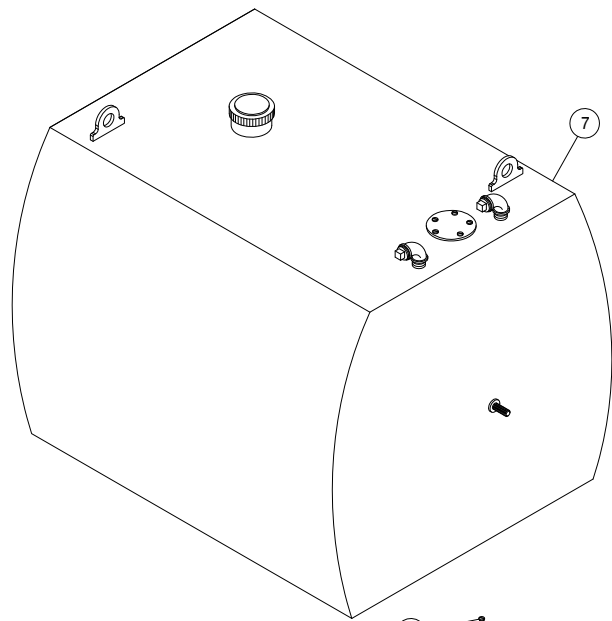

SERVICE PLATFORM ASSEMBLY

DET. QTY PART NO. DESCRIPTION

1	2	293403	TAIL/TURN LIGHT ASSY, 2100	98
2	2	341900	SERVICE PLATFORM MT KPR	90
3	1	342538	RH SERVICE PLATFORM WLD2100	98
4	1	342539	LH SERVICE PLATFORM WLD2100	98
5	1	343221	REAR SERV PLATFORM WLD,2100	03
6	2	342565	CNTR SERV PLTFRM MT PLT2100	98
7	1	342566	RH UPPER SIDE RAIL TUBE WLD	98
8	1	342567	LH UPPER SIDE RAIL TUBE WLD	98
9	1	342576	REAR HANDRAIL WLD, 2100	98
10	1	342628	RH TREAD ADJ GAUGE MT	98
11	1	342629	LH TREAD ADJ GAUGE MT	98
12	1	342641	REAR HANDRAIL EXT WLD, 2100	98
13	1	342645	STEP EXT WLD, 2100	98
14	1	342650	RH REAR TRD IND WLD, 2100	98
15	1	342651	LH REAR TRD IND WLD, 2100	98
16	2	470118	1/4UNC X 3/4 FLANGE HEX BOLT	
17	2	470121	1/4UNC HEX FLANGE LOCK NUT	
18	1	472251	MTG SOCKET FOR 472249 SMV SIGN	
19	1	656886	SLO MOVING VEHICLE SIGN ASSY	
20	10	920001	5/16 SAE FLAT WASHER	
21	1	900005	1/4UNC X 1 1/2 HEX BOLT	
22	4	900068	5/16UNC X 1 3/4 HEX BOLT	
23	10	900065	5/16UNC X 1" HEX BOLT	
24	24	900129	3/8UNC X 1" SERR FLANGE BOLT	
25	8	900266	1/2UNC X 1 3/4 HEX BOLT	
26	1	914000	1/4UNC HEX STOVER NUT	
27	14	914002	5/16UNC HEX STOVER NUT	
28	12	914008	1/2UNC HEX STOVER NUT	
29	24	914004	3/8UNC HEX STOVER NUT	
30	1	164364	RH LIFTARM V-PLT MT WLD2100	98
31	1	164365	LH LIFTARM V-PLT MT WLD2100	98
32	4	900265	1/2UNC X 1 1/2 HEX BOLT	
33	8	920004	1/2 SAE FLAT WASHER	

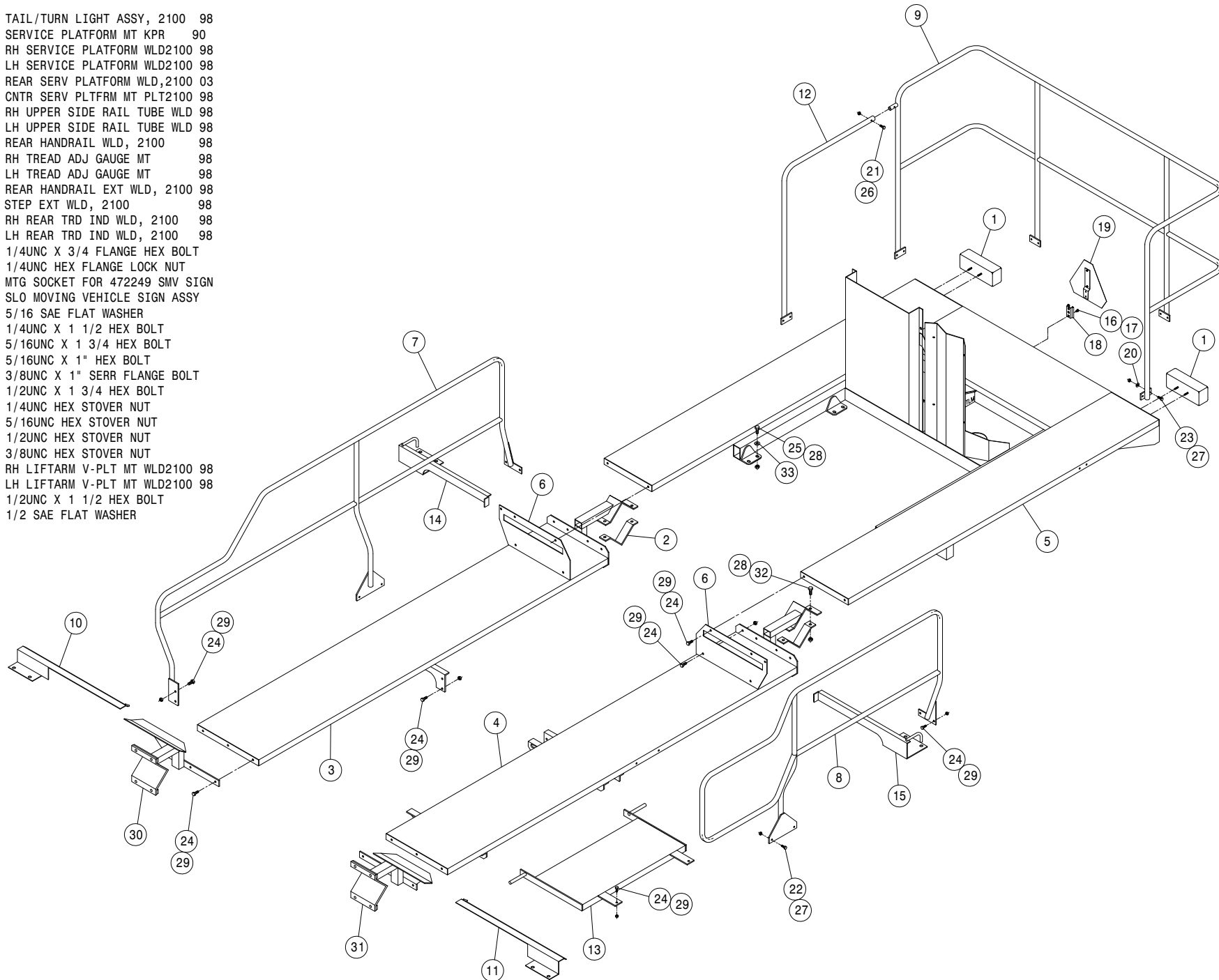

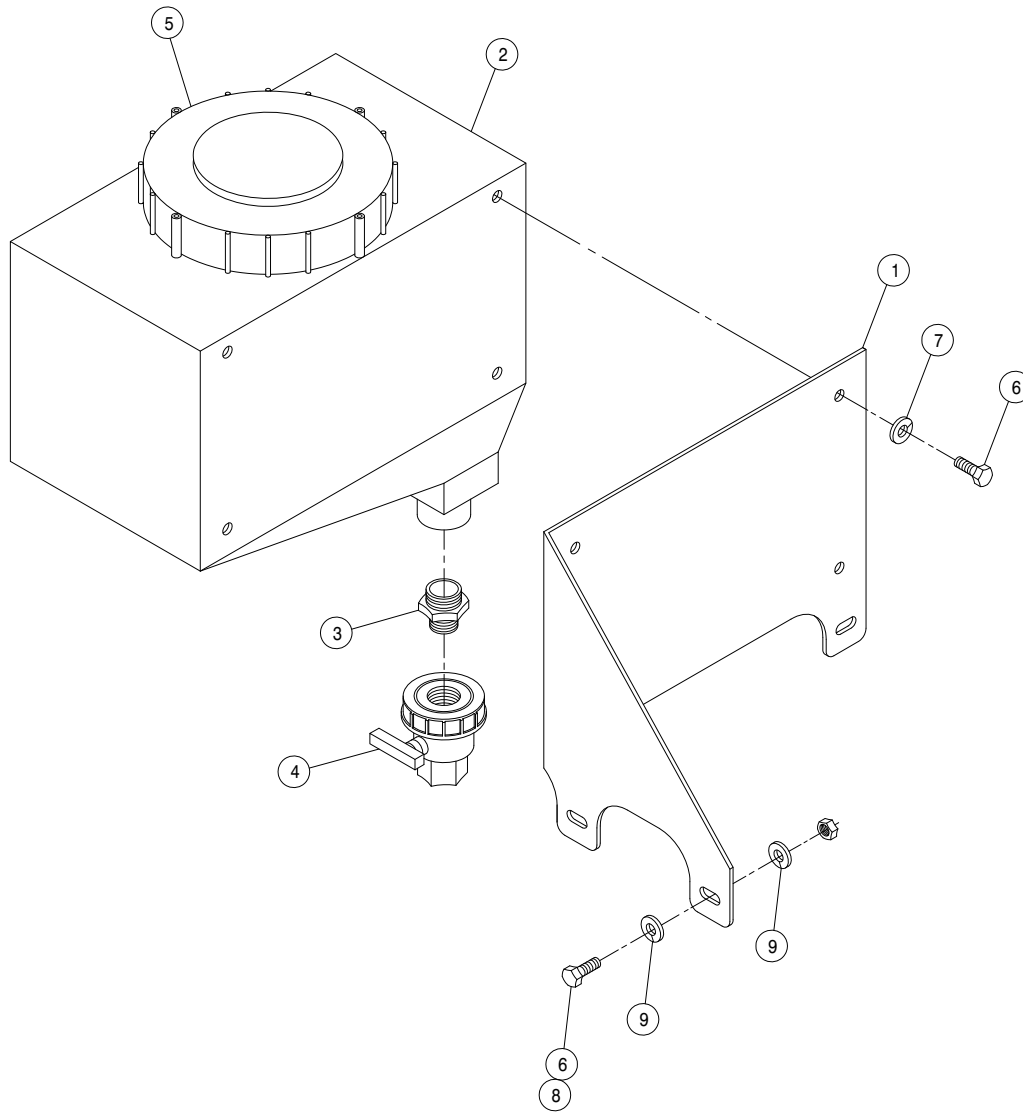

FRESH WATER TANK ASSEMBLY

DET. QTY PART NO. DESCRIPTION

1	1	343264	FRESH WATER TANK MT, 2101 04
2	1	470318	RINSE TANK, 3 GAL SQ SAFETY
3	1	500124	3/4 X 1/2NPT REDU NIPPLE, POLY
4	1	696005	BALL VLV, .500NPT, 100PSI, POLY
5	1	470337	6" LID FOR 3 GAL TANK 470318
6	7	900064	5/16UNC X 3/4 HEX BOLT
7	4	920501	5/16 LOCK WASHER
8	3	914002	5/16UNC HEX STOVER NUT
9	6	920001	5/16 SAE FLAT WASHER

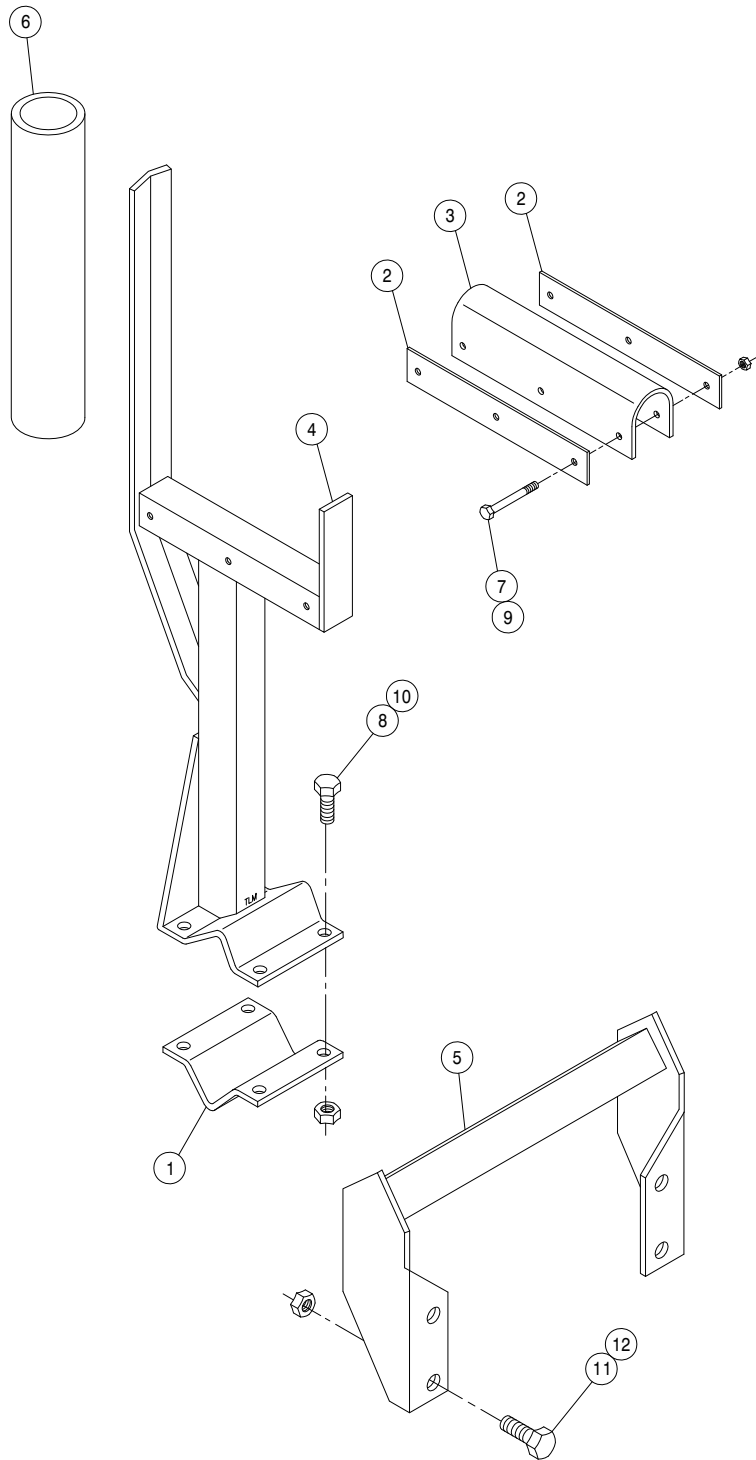

BOOM CRADLE ASSEMBLY

DET. QTY PART NO. DESCRIPTION

1	2	164253	BOOM CRADLE V-PLT KEEPER	96
2	4	164254	CRADLE CUSHION KEEPER	96
3	2	164256	BOOM CRADLE CUSHION	96
4	2	164372	BOOM CRADLE WLD, 2100	98
5	2	164376	BOOM CRADLE MT WLD, 2100	98
6	2	601184	HOSE, 1 1/2 X 14 2BR BLK EPDM	
7	6	900008	1/4UNC X 2 1/2 HEX BOLT	
8	8	900265	1/2UNC X 1 1/2 HEX BOLT	
9	6	914000	1/4UNC HEX STOVER NUT	
10	8	914008	1/2UNC HEX STOVER NUT	
11	8	900334	5/8UNC X 1 3/4 HEX BOLT	
12	8	914010	5/8UNC HEX STOVER NUT	

NOTE: QUANTITY LISTED IS FOR ONE MACHINE.

BATTERY BOX ASSEMBLY

DET. QTY PART NO. DESCRIPTION

1	1	291998	BATT CABLE,BLK 72"1/0.406-.406
2	1	291999	BATT CABLE,RED 74"1/0.406-.406
3	1	292522	BATT CABLE,RED 25"1/0.406-.406
4	1	292526	BATT CABLE,BLK 26"1/0.406-.406
5	1	291864	BATT CABLE,RED 16"1/0.406-.406
6	2	291196	BATTERY,12V 950CCA, SS STUD
7	4	291205	BATTERY NUT,3/8-16 SS CLSD CAP
8	1	291680	POSITIVE JUMPER STUD, RED
9	1	291681	NEGATIVE JUMPER STUD, BLACK
10	1	292548	BATT CBL,RED 46" 2GA .343-.406
11	1	316842	BATTERY TRAY, DTS10 '10
12	2	316843	BATTERY HOLD-DOWN, DTS10 '10
13	4	901129	3/8UNC X 1" CARR BOLT
14	9	470087	3/8UNC HEX FLANGE LOCK NUT
15	5	900128	3/8UNC X 3/4 HEX BOLT
16	1	292521	BATT CABLE,BLK 24"1/0.406-.406

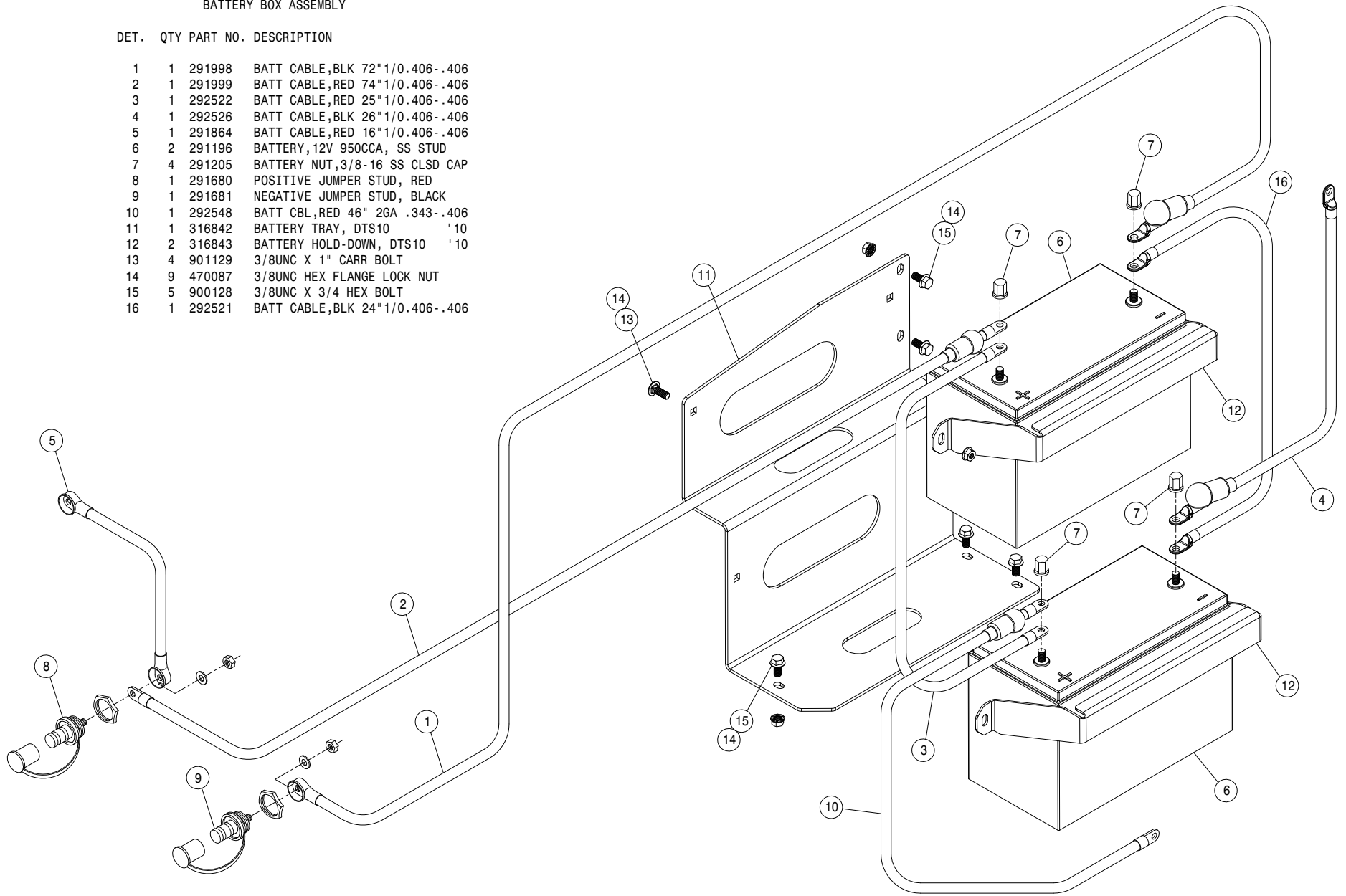

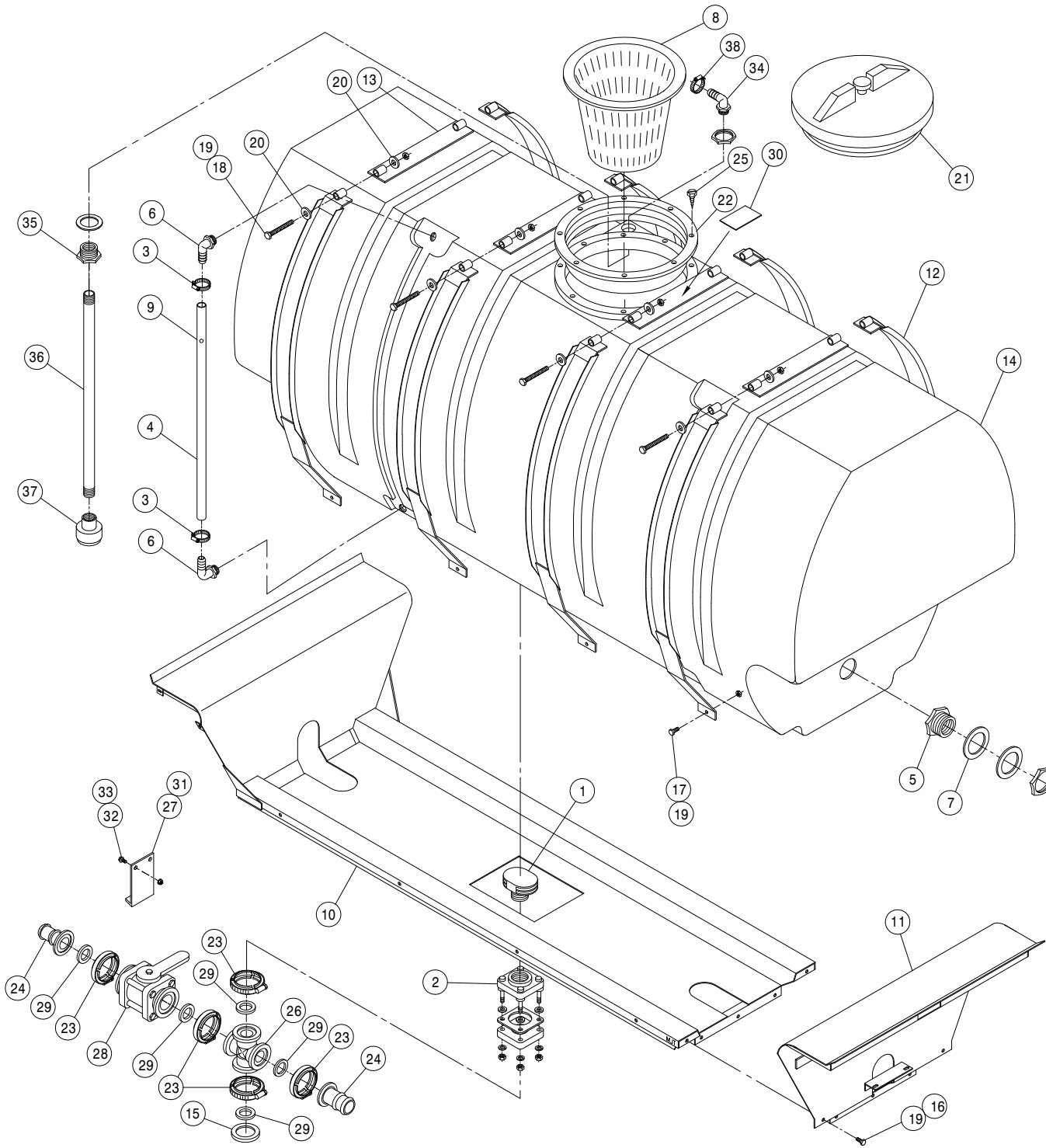

RIGHT POLY SOLUTION TANK ASSEMBLY

DET. QTY PART NO. DESCRIPTION

1	1	500077	VENT CAP, 2" W/O SCREEN,POLY
2	1	500179	2"FLG TANK FTG,BOTDRN BLT POLY
3	2	520069	HOSE CLAMP NO 6 STAINLESS
4	1	601245	HOSE, 1/2 X 42 CLEAR VINYL
5	2	618548	1.25 PLASTIC FTG ASSY POLYTNK
6	2	618556	1/4NPT-90-1/2 HOSE BARB,POLY
7	2	763430	1 1/4 TANK FLANGE RUBBER SEAL
8	1	763431	8" STRAINER BASKET, SOLU TANK
9	1	763446	RED POLYPROPYLENE BALL 25/64"
10	1	763652	POLY TANK CRADLE WLD, 2101 04
11	1	763502	REAR CRADLE MT WLD, 2100 98
12	8	763507	TANK BAND WLD, 2100 POLY 98
13	4	763511	TANK BAND TIE WLD, 2100 98
14	1	763513	500 GAL POLY SOLU TANK 98
15	1	500156	2" FLANGE CAP PLUG POLY
16	5	900129	3/8UNC X 1" SERR FLANGE BOLT
17	8	900130	3/8UNC X 1 1/4 SER FLANGE BOLT
18	8	906138	3/8UNC X 3 1/2 HEX BOLT FULL
19	21	914004	3/8UNC HEX STOVER NUT
20	16	920002	3/8 SAE FLAT WASHER
21	1	763408	LID, THD'D W/VENT, POLY TANK
22	1	763409	10" THD'D RING FOR TANK LID
23	5	500160	2" FLANGE CLAMP, S.S.
24	2	500162	2" FLANGE-1 1/2 HOSE BARB POLY
25	8	763410	S.S. SCREW FOR CAP RING
26	1	500176	2" FLANGE CROSS POLY
27	1	763363	SOLU HOSE SUPPORT 280 POLY 91
28	1	696142	BALL VLV, 2" FLANGE
29	5	500158	1 1/2" GASKET FOR 2" FLANGE
30	1	650850	DECAL,WARNING, DANGEROUS CHEM
31	1	470000	CABLE TIE, 1/2 X 28" BLACK NYL
32	2	470118	1/4UNC X 3/4 FLANGE HEX BOLT
33	2	470121	1/4UNC HEX FLANGE LOCK NUT
34	1	500054	3/4NPT-90-3/4 HOSE BARB, POLY
35	1	500110	3/4NPT BLKHD TANK FITTING POLY
36	1	504850	CPVC PIPE NIPPLE .75NPT-24.00
37	1	737873	ROTARY NOZZLE, TEFLON
38	1	520055	HOSE CLAMP NO 12 STAINLESS

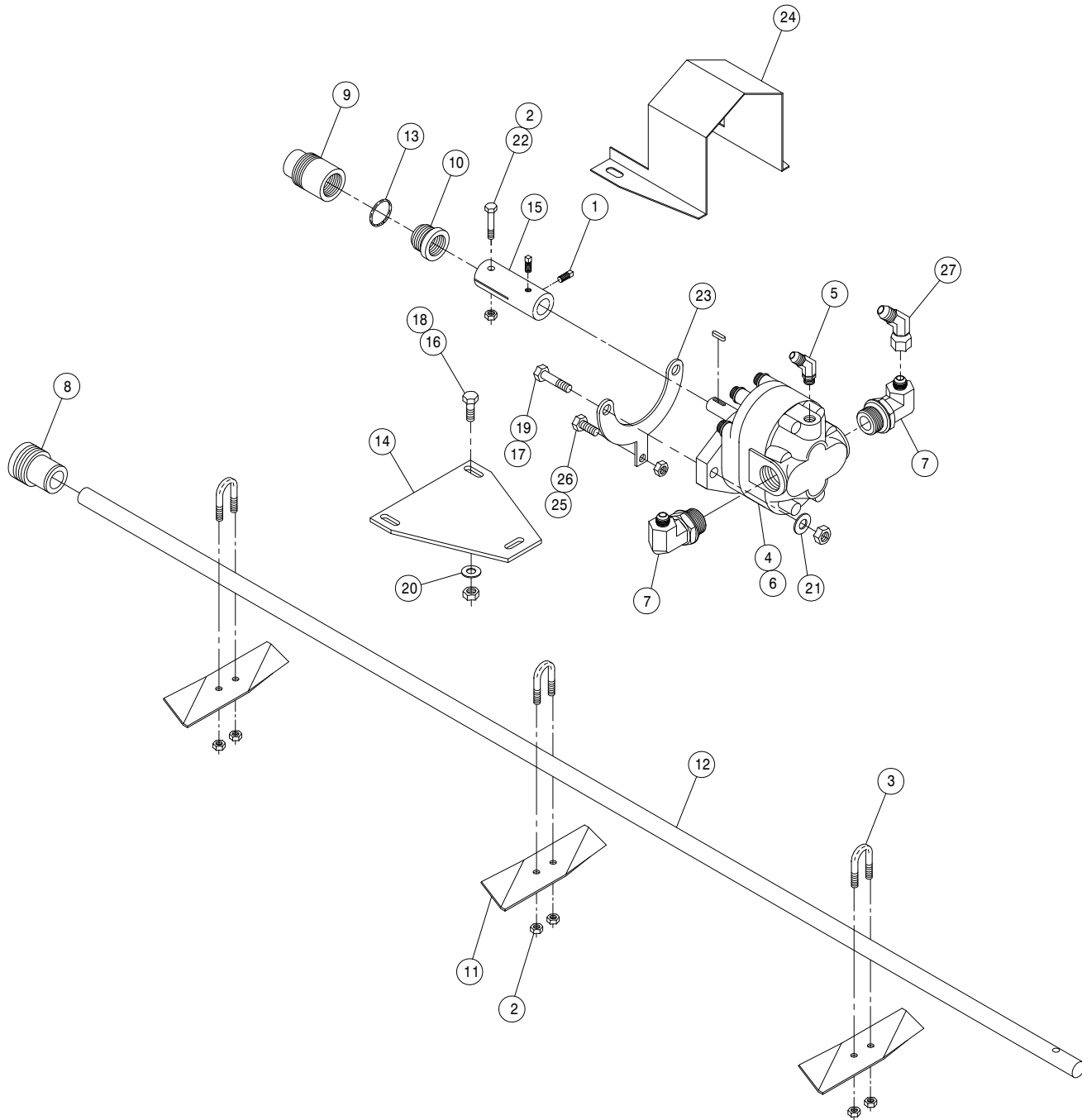

RIGHT AGITATOR ASSEMBLY

DET.	QTY	PART NO.	DESCRIPTION
1	2	470199	1/4UNC X 3/8 SQ HD CUP SET SCR
2	7	470089	1/4UNC HEX NYLOC NUT, 316 SS
3	3	470092	1/4UNC-3/4ID-1 1/4 U-BOLT SS
4	1	606324	GEAR MTR,1.41CI EATON
5	1	618425	9/16MJIC-45-9/16MOR LBO
6	1	606313	SHAFT SEAL FOR 606324
7	2	618813	9/16MJIC-90-1 1/16MOR LBO
8	1	706403	FRT AGIT SHFT BRG, NYLON
9	1	706401	REAR AGIT SHFT BRG, NYLON
10	1	706402	AGIT SHFT GLAND NUT, NYLON
11	3	763027	AGIT IMPELLER
12	1	763514	AGIT SHAFT, 2100 98
13	1	763217	GLAND PACKING, 13 IN. LONG
14	1	763357	AGIT MTR MT PLT CES 280 91
15	1	763359	AGIT MTR CPLR 280 91
16	2	900064	5/16UNC X 3/4 HEX BOLT
17	2	900130	3/8UNC X 1 1/4 SER FLANGE BOLT
18	2	914002	5/16UNC HEX STOVER NUT
19	2	914004	3/8UNC HEX STOVER NUT
20	2	920001	5/16 SAE FLAT WASHER
21	2	920002	3/8 SAE FLAT WASHER
22	1	470200	1/4UNC X 1 3/4 HEX BOLT SS
23	1	763358	AGIT MTR MT YOKE CES 280 91
24	1	763361	AGIT CPLR SHIELD 280 91
25	1	900000	1/4UNC X 1/2 HEX BOLT
26	1	914000	1/4UNC HEX STOVER NUT
27	1	618634	9/16MJIC-45-9/16FJIC SWIV LBO

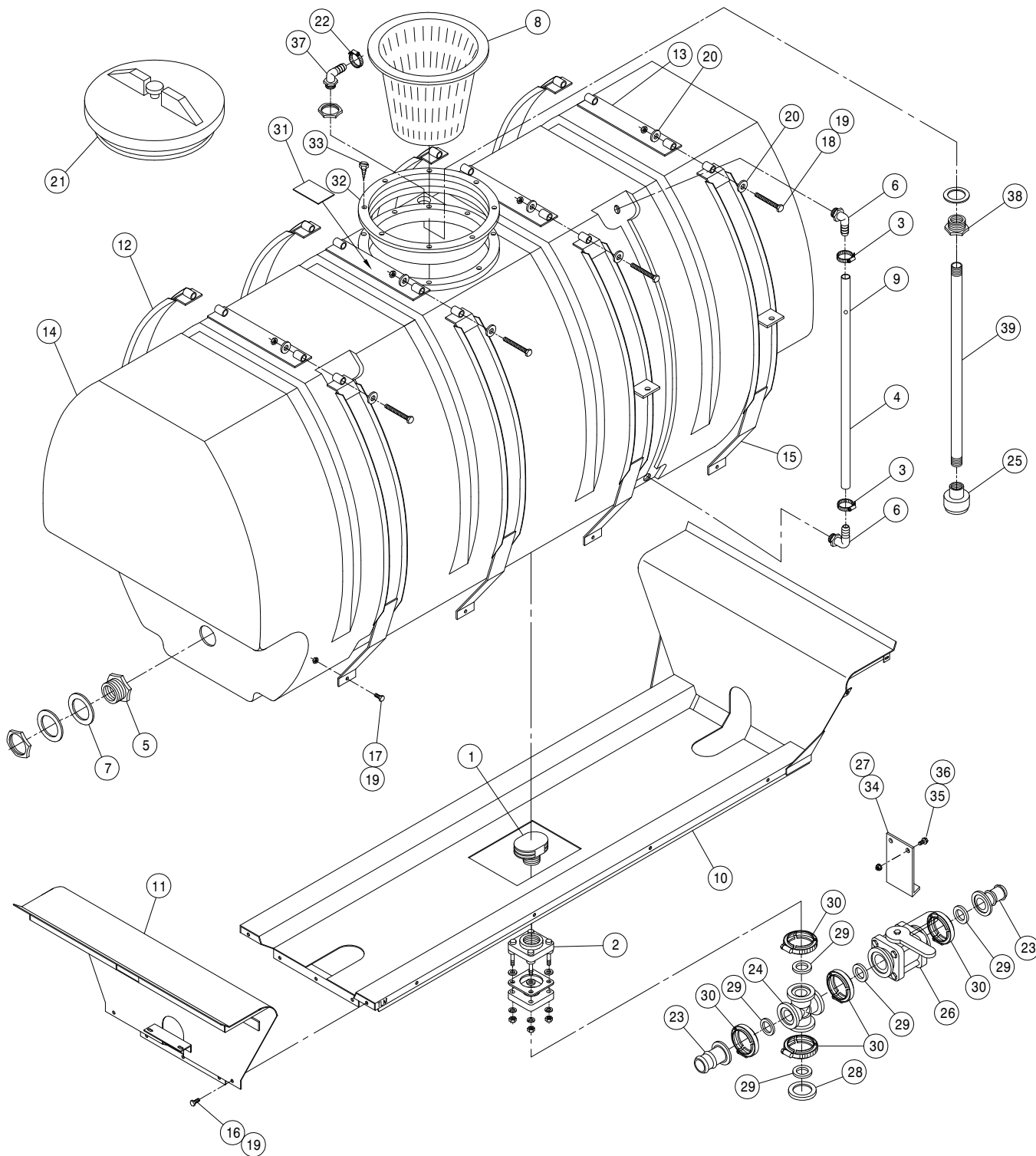

LEFT POLY SOLUTION TANK ASSEMBLY

DET. QTY PART NO. DESCRIPTION

DET.	QTY	PART NO.	DESCRIPTION
	1	500077	VENT CAP, 2" W/O SCREEN,POLY
	1	500179	2"FLG TANK FTG,BOTDRN BLT POLY
	2	520069	HOSE CLAMP NO 6 STAINLESS
	1	601245	HOSE, 1/2 X 42 CLEAR VINYL
	2	618548	1.25 PLASTIC FTG ASSY POLYTNK
	2	618556	1/4NPT-90-1/2 HOSE BARB,POLY
	2	763430	1 1/4 TANK FLANGE RUBBER SEAL
	1	763431	8" STRAINER BASKET, SOLU TANK
	1	763446	RED POLYPROPYLENE BALL 25/64"
	10	763652	POLY TANK CRADLE WLD, 2101 04
	1	763502	REAR CRADLE MT WLD, 2100 98
	6	763507	TANK BAND WLD, 2100 POLY 98
	4	763511	TANK BAND TIE WLD, 2100 98
	1	763513	500 GAL POLY SOLU TANK 98
	2	763515	TANK BAND W/TAB WLD, 2100 98
	5	900129	3/8UNC X 1" SERR FLANGE BOLT
	8	900130	3/8UNC X 1 1/4 SER FLANGE BOLT
	8	906138	3/8UNC X 3 1/2 HEX BOLT FULL
	21	914004	3/8UNC HEX STOVER NUT
	16	920002	3/8 SAE FLAT WASHER
	1	763408	LID, THD'D W/VENT, POLY TANK
	1	520055	HOSE CLAMP NO 12 STAINLESS
	2	500162	2" FLANGE-1 1/2 HOSE BARB POLY
	1	500176	2" FLANGE CROSS POLY
	1	737873	ROTARY NOZZLE, TEFLON
	1	696142	BALL VLV, 2" FLANGE
	1	470000	CABLE TIE, 1/2 X 28" BLACK NYL
	1	500156	2" FLANGE CAP PLUG POLY
	5	500158	1 1/2" GASKET FOR 2" FLANGE
	5	500160	2" FLANGE CLAMP, S.S.
	1	650850	DECAL,WARNING, DANGEROUS CHEM
	1	763409	10" THD'D RING FOR TANK LID
	8	763410	S.S. SCREW FOR CAP RING
	1	763363	SOLU HOSE SUPPORT 280 POLY 91
	2	470118	1/4UNC X 3/4 FLANGE HEX BOLT
	2	470121	1/4UNC HEX FLANGE LOCK NUT
	1	500054	3/4NPT-90-3/4 HOSE BARB, POLY
	1	500110	3/4NPT BLKHD TANK FITTING POLY
	1	504850	CPVC PIPE NIPPLE .75NPT-24.00

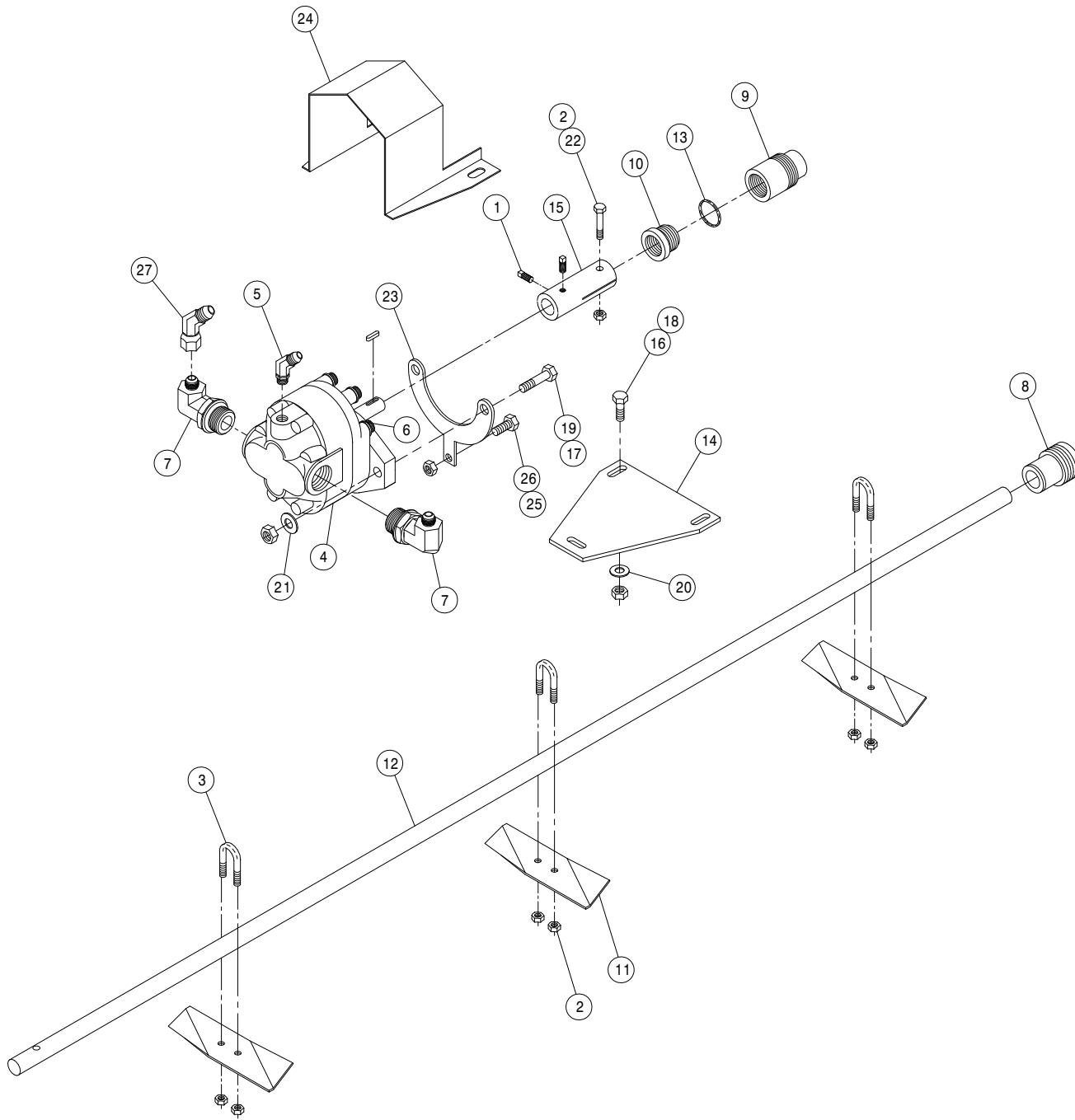

LEFT AGITATOR ASSEMBLY

DET. QTY PART NO. DESCRIPTION

1	2	470199	1/4UNC X 3/8 SQ HD CUP SET SCR	
2	7	470089	1/4UNC HEX NYLOC NUT, 316 SS	
3	3	470092	1/4UNC-3/4ID-1 1/4 U-BOLT SS	
4	1	606324	GEAR MTR, 1.41CI EATON	
5	1	618338	9/16MJIC-45-1/4MNPT LBO	
6	1	606313	SHAFT SEAL FOR 606324	
7	2	618107	9/16MJIC-90-1/2MNPT LBO	
8	1	706403	FRT AGIT SHFT BRG, NYLON	
9	1	706401	REAR AGIT SHFT BRG, NYLON	
10	1	706402	AGIT SHFT GLAND NUT, NYLON	
11	3	763027	AGIT IMPELLER	
12	1	763514	AGIT SHAFT, 2100	98
13	1	763217	GLAND PACKING, 13 IN. LONG	
14	1	763357	AGIT MTR MT PLT CES 280	91
15	1	763359	AGIT MTR CPLR 280	91
16	2	900064	5/16UNC X 3/4 HEX BOLT	
17	2	900130	3/8UNC X 1 1/4 SER FLANGE BOLT	
18	2	914002	5/16UNC HEX STOVER NUT	
19	2	914004	3/8UNC HEX STOVER NUT	
20	2	920001	5/16 SAE FLAT WASHER	
21	2	920002	3/8 SAE FLAT WASHER	
22	1	470200	1/4UNC X 1 3/4 HEX BOLT SS	
23	1	763358	AGIT MTR MT YOKE CES 280	91
24	1	763361	AGIT CPLR SHIELD 280	91
25	1	900000	1/4UNC X 1/2 HEX BOLT	
26	1	914000	1/4UNC HEX STOVER NUT	
27	1	618634	9/16MJIC-45-9/16FJIC SWIV LBO	

SOLUTION TANK MOUNTS AND SHIELDS

DET. QTY PART NO. DESCRIPTION

1	2	193016	QUICKEDGE TRIM .060 TO .170	
2	2	293402	HEADLIGHT ASSY, 2100	98
3	2	358958	LEG BRACE WLD, 2100	99
4	2	470100	3/8 INT TOOTH LOCK WASHER	
5	32	470118	1/4UNC X 3/4 FLANGE HEX BOLT	
6	34	470121	1/4UNC HEX FLANGE LOCK NUT	
7	2	473779	10MM-1.50 HEX NUT	
8	2	473971	1/4UNC-2"ID-3"RD U-BOLT	
9	1	659831	LWR FRONT SHIELD 280	89
10	1	659963	RH FRT TANK SHLD WLD 2100	98
11	1	659964	LH FRT TANK SHLD WLD 2100	98
12	2	659968	HEADLIGHT MT WLD, 2100	98
13	1	763476	RH FRT SOLU TNK MT WLD,2100	98
14	1	763477	LH FRT SOLU TNK MT WLD,2100	98
15	1	763478	RH REAR SOLU TNK MT WLD2100	98
16	1	763479	LH REAR SOLU TNK MT WLD2100	98
17	4	763490	SOLU TANK MT SUPP, 2100	98
18	12	900334	5/8UNC X 1 3/4 HEX BOLT	
19	8	900412	3/4UNC X 5" HEX BOLT	
20	2	910017	1-8 HEX NUT	
21	12	914010	5/8UNC HEX STOVER NUT	
22	10	914012	3/4UNC HEX STOVER NUT	
23	4	920008	1" SAE FLAT WASHER	
24	2	920508	1" LOCK WASHER	
25	2	358961	LEG BRACE CLEVIS WLD, 2100	99
26	2	900410	3/4UNC X 4" HEX BOLT	
27	2	900814	1" UNC X 4" HEX BOLT	GR8
28	26	470212	1/4 BONDED SEALING WASH, SS	
29	2	659919	FRT SHIELD EXT, D230 PUMP	

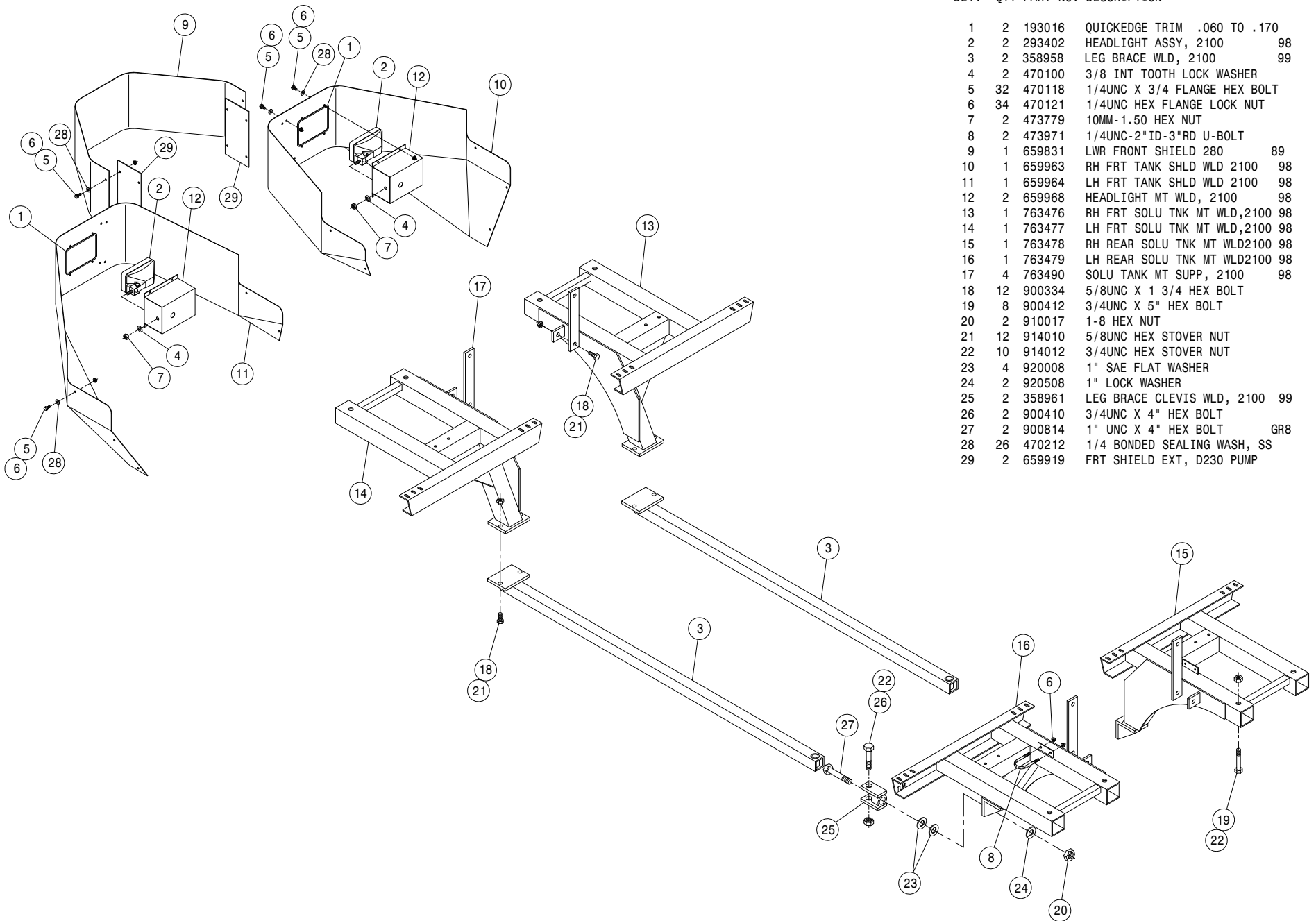

60' SOLUTION SOLENOID ASSEMBLY (STANDARD)

DET. QTY PART NO. DESCRIPTION

1	2	470121	1/4UNC HEX FLANGE LOCK NUT
2	3	520090	HOSE CLAMP NO 16 STAINLESS
3	1	601451	HOSE, 2 X 69 2F-1W EPDM
4	3	500173	1" FLANGE-90-1" HOSE BARB POLY
5	1	500154	2" FLANGE-2" HOSE BARB POLY
6	5	500157	1" FLANGE GASKET EPDM
7	5	500158	1 1/2" GASKET FOR 2" FLANGE
8	5	500159	1" FLANGE CLAMP, S.S.
9	5	500160	2" FLANGE CLAMP, S.S.
10	4	914004	3/8UNC HEX STOVER NUT
11	2	470136	3/8UNC-3 1/16ID-3 SQ U-BOLT
12	1	500180	2"FLANGE-90-2"FLANGE LBO POLY
13	1	500181	2" FLANGE PLUG W/1/4"FNPT POLY
14	1	690359	PRESSURE GA GLYCERI 100 PSI
15	1	696266	VALVE,3-SECT KZCO FLG, PACKARD
16	1	500119	1/2"NPT BR TEE-1/2"HBARB, POLY
17	1	500151	2" FLANGE TEE POLY
18	1	500175	1" FLANGE TEE POLY
19	3	520141	2.31/2.62 T-BOLT HOSE CLAMP SS
20	2	500058	2"NPT X 2" H BARB, POLY
21	1	601450	HOSE, 2 X 84 2F-1W EPDM
22	2	520056	HOSE CLAMP NO 56 STAINLESS
23	2	470118	1/4UNC X 3/4 FLANGE HEX BOLT
24	1	690529	RFM 100 FLOW METER, RAVEN
25	1	500224	2" FLANGE PLUG W/1/2"FNPT POLY
26	1	500226	1" FLANGE PLUG W/1/4"FNPT POLY
27	1	618556	1/4NPT-90-1/2 HOSE BARB,POLY
28	3	696273	VALVE,REPLCMNT SECT FOR 696266
29	4	696254	O-RING, KZCO FLANGED VALVES

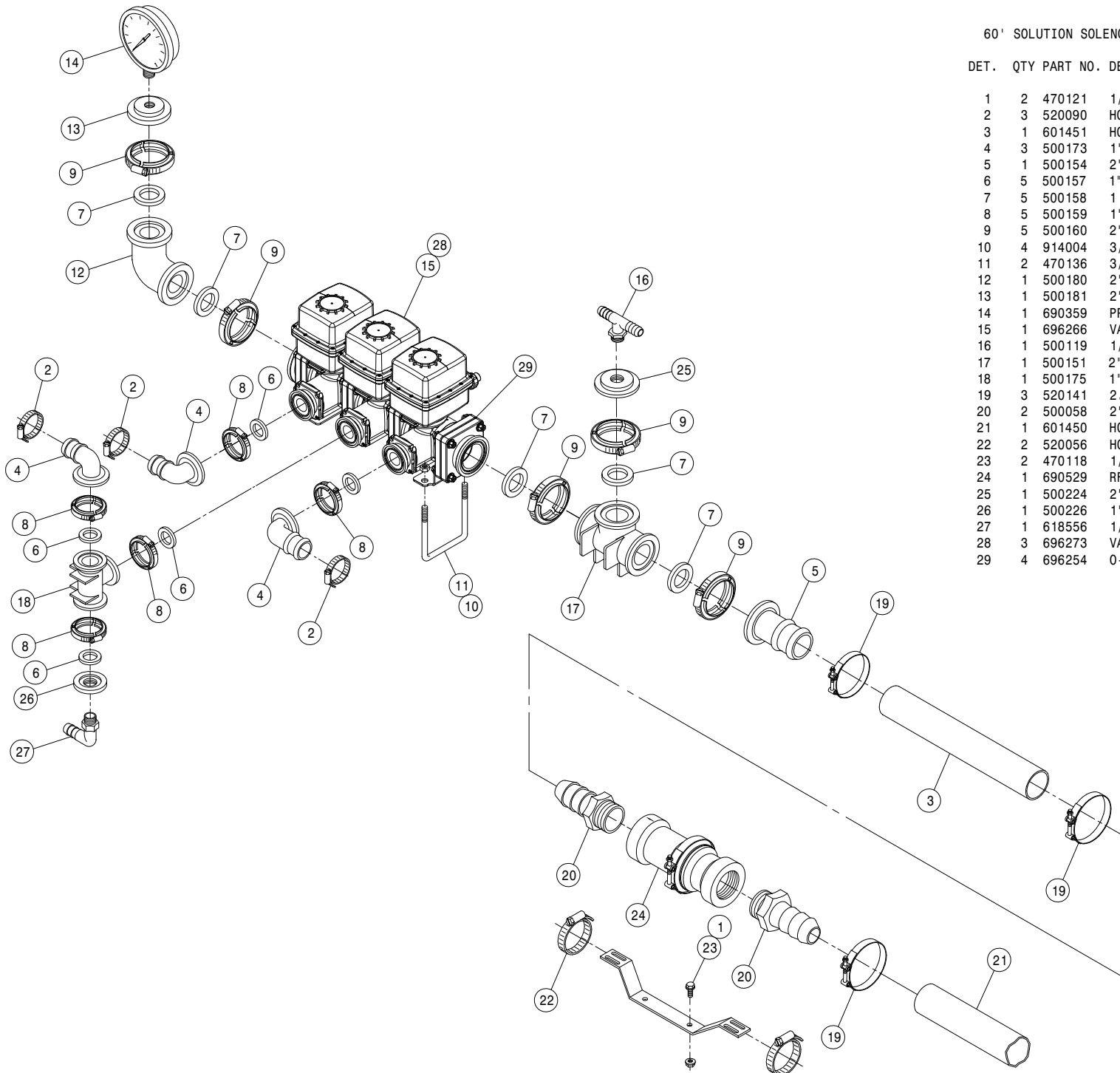

80' -90' SOLUTION SOLENOID ASSEMBLY (STANDARD)

DET. QTY PART NO. DESCRIPTION

DET.	QTY	PART NO.	DESCRIPTION
1	2	470121	1/4UNC HEX FLANGE LOCK NUT
2	5	520090	HOSE CLAMP NO 16 STAINLESS
3	2	500151	2" FLANGE TEE POLY
4	3	500173	1" FLANGE-90-1" HOSE BARB POLY
5	1	500154	2" FLANGE-2" HOSE BARB POLY
6	5	500157	1" FLANGE GASKET EPDM
7	7	500158	1 1/2" GASKET FOR 2" FLANGE
8	5	500159	1" FLANGE CLAMP, S.S.
9	7	500160	2" FLANGE CLAMP, S.S.
10	4	914004	3/8UNC HEX STOVER NUT
11	2	500172	2" FLANGE-1" HOSE BARB POLY
12	1	500180	2"FLANGE-90-2"FLANGE LBO POLY
13	1	500181	2" FLANGE PLUG W/1/4"FNPT POLY
14	1	690359	PRESSURE GA GLYCERI 100 PSI
15	1	696266	VALVE,3-SECT KZCO FLG, PACKARD
16	1	500175	1" FLANGE TEE POLY
17	1	500226	1" FLANGE PLUG W/1/4"FNPT POLY
18	1	618556	1/4NPT-90-1/2 HOSE BARB,POLY
19	3	520141	2.31/2.62 T-BOLT HOSE CLAMP SS
20	2	500058	2"NPT X 2" H BARB, POLY
21	1	601450	HOSE, 2 X 84 2F-1W EPDM
22	2	520056	HOSE CLAMP NO 56 STAINLESS
23	2	470118	1/4UNC X 3/4 FLANGE HEX BOLT
24	1	690529	RFM 100 FLOW METER, RAVEN
25	1	601451	HOSE, 2 X 69 2F-1W EPDM
26	2	470136	3/8UNC-3 1/16ID-3 SQ U-BOLT
27	3	696273	VALVE,REPLCMNT SECT FOR 696266
28	4	696254	O-RING, KZCO FLANGED VALVES

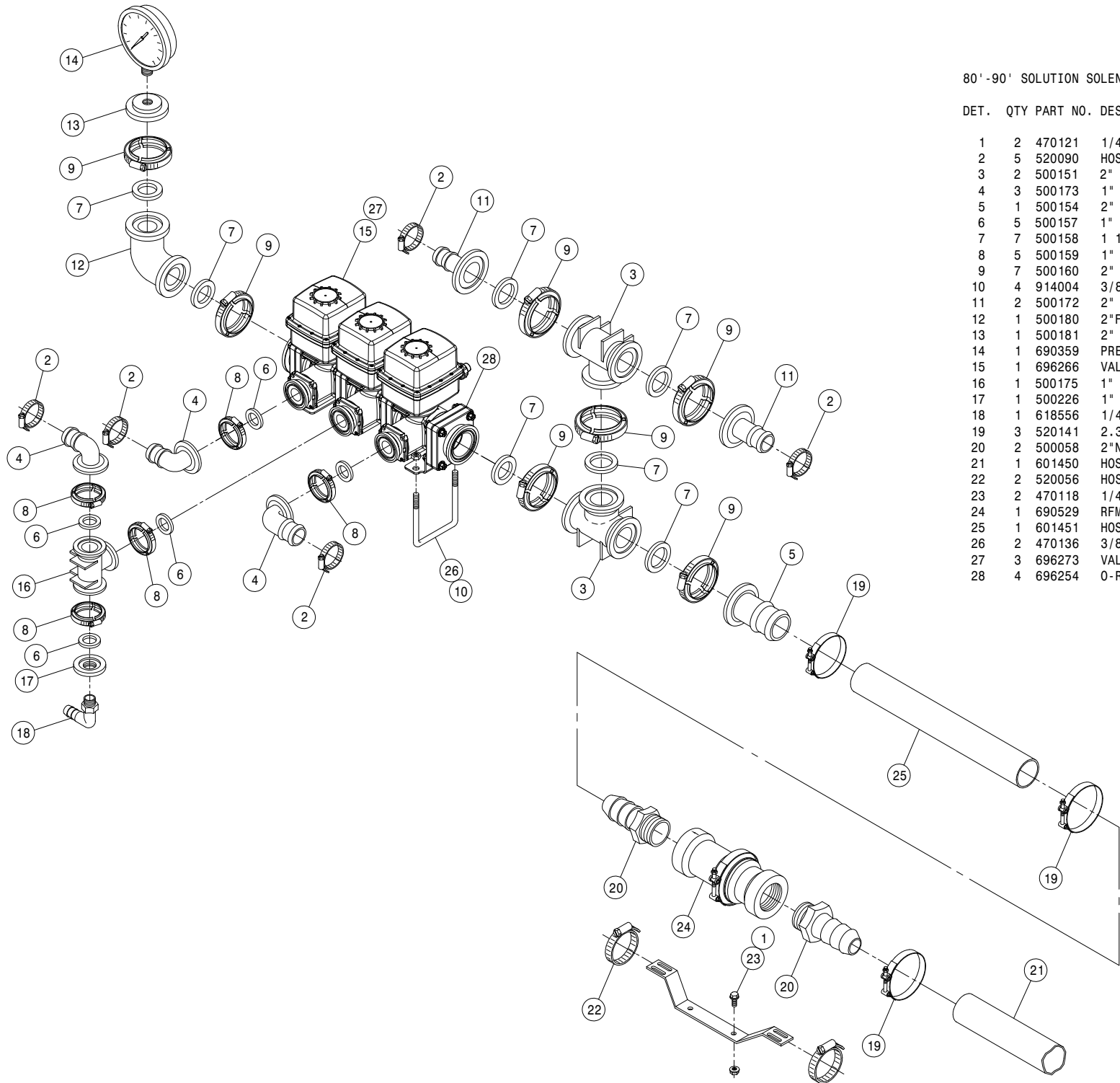

RIGHT 80'-90' OUTER BOOM VALVE (STANDARD)

DET. QTY PART NO. DESCRIPTION

1	2	470121	1/4UNC HEX FLANGE LOCK NUT
2	2	470118	1/4UNC X 3/4 FLANGE HEX BOLT
3	2	520090	HOSE CLAMP NO 16 STAINLESS
4	4	500157	1" FLANGE GASKET EPDM
5	4	500159	1" FLANGE CLAMP, S.S.
6	1	500171	1" FLANGE-1" HOSE BARB POLY
7	1	500173	1" FLANGE-90-1" HOSE BARB POLY
8	1	696282	VALVE,KZCO C2E 1"FLG ELEC W/WP
9	1	500226	1" FLANGE PLUG W/1/4"FNPT POLY
10	1	618556	1/4NPT-90-1/2 HOSE BARB,POLY
11	1	500175	1" FLANGE TEE POLY

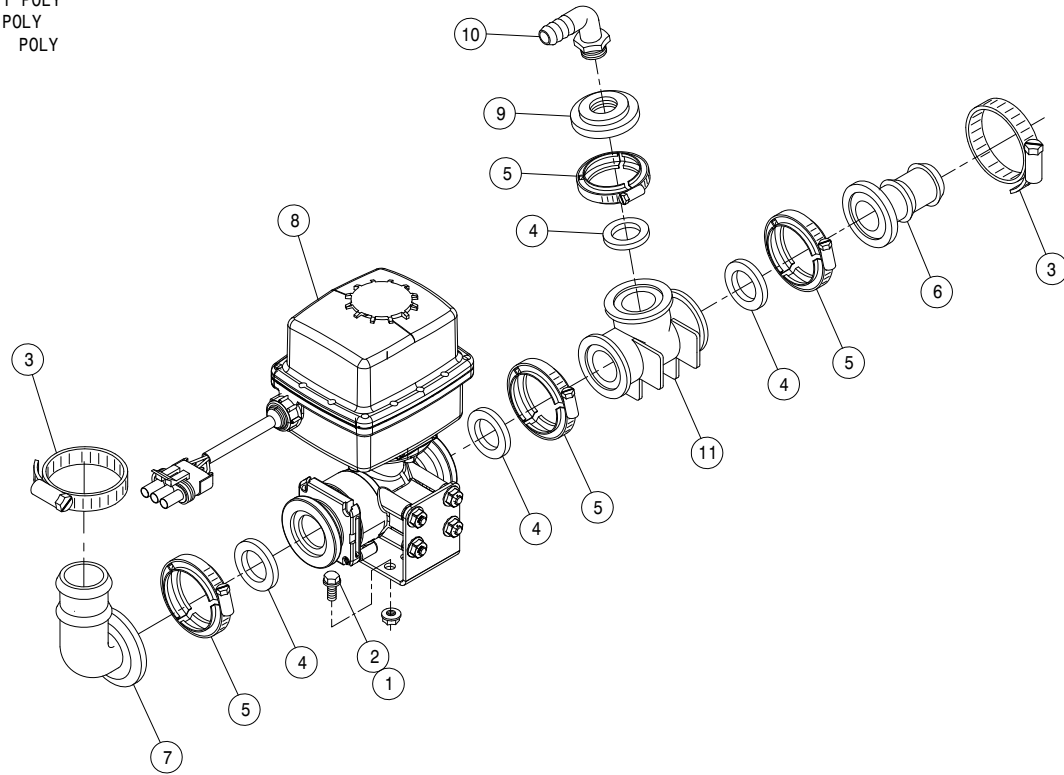

LEFT 80'-90' OUTER BOOM VALVE (STANDARD)

DET. QTY PART NO. DESCRIPTION

1	2	470121	1/4UNC HEX FLANGE LOCK NUT
2	2	470118	1/4UNC X 3/4 FLANGE HEX BOLT
3	2	520090	HOSE CLAMP NO 16 STAINLESS
4	4	500157	1" FLANGE GASKET EPDM
5	4	500159	1" FLANGE CLAMP, S.S.
6	1	500171	1" FLANGE-1" HOSE BARB POLY
7	1	500173	1" FLANGE-90-1" HOSE BARB POLY
8	1	696282	VALVE,KZCO C2E 1"FLG ELEC W/WP
9	1	500226	1" FLANGE PLUG W/1/4"FNPT POLY
10	1	618556	1/4NPT-90-1/2 HOSE BARB,POLY
11	1	500175	1" FLANGE TEE POLY

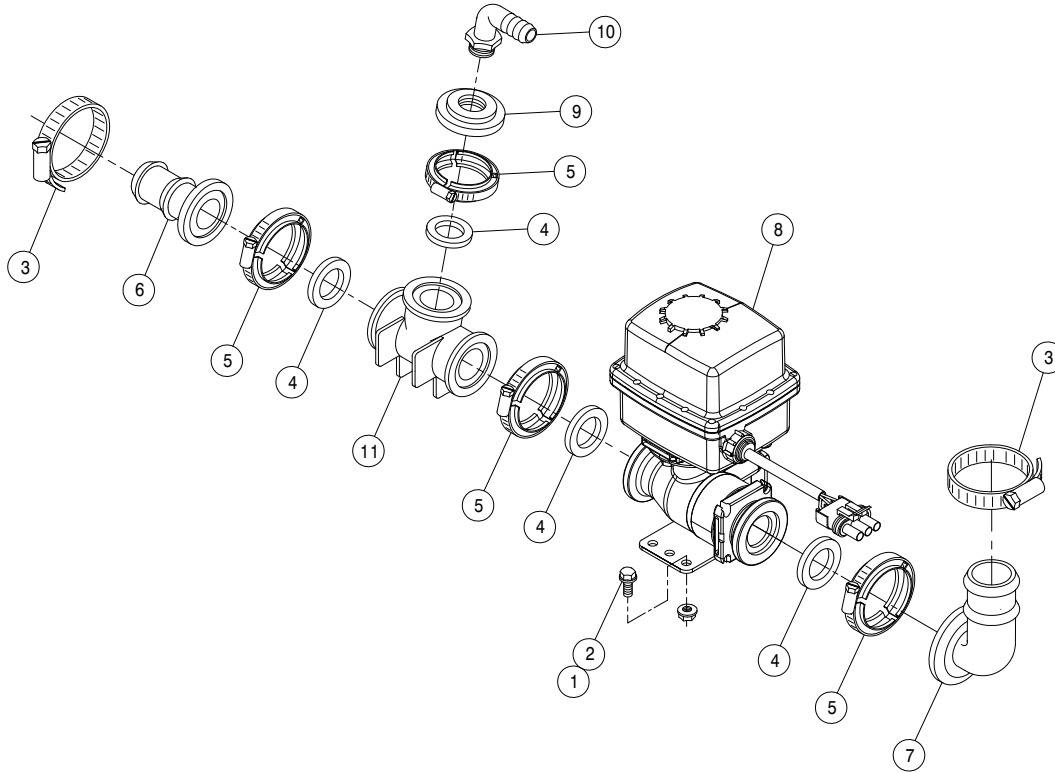

60' SOLUTION SOLENOID ASSEMBLY (HI-VOLUME)

DET. QTY PART NO. DESCRIPTION

1	2	470121	1/4UNC HEX FLANGE LOCK NUT
2	3	520067	HOSE CLAMP NO 28 STAINLESS
3	2	470136	3/8UNC-3 1/16ID-3 SQ U-BOLT
4	3	500153	2" FLANGE-90-1 1/2 HBARB POLY
5	1	500154	2" FLANGE-2" HOSE BARB POLY
6	5	500157	1" FLANGE GASKET EPDM
7	8	500158	1 1/2" GASKET FOR 2" FLANGE
8	5	500159	1" FLANGE CLAMP, S.S.
9	8	500160	2" FLANGE CLAMP, S.S.
10	3	500161	2"FLANGE-1"FLANGE COUPLER,POLY
11	4	914004	3/8UNC HEX STOVER NUT
12	1	500180	2"FLANGE-90-2"FLANGE LBO POLY
13	1	500181	2" FLANGE PLUG W/1/4"FNPT POLY
14	1	690359	PRESSURE GA GLYCERI 100 PSI
15	1	696266	VALVE,3-SECT KZCO FLG, PACKARD
16	1	500119	1/2"NPT BR TEE-1/2"HBARB, POLY
17	1	500151	2" FLANGE TEE POLY
18	1	500175	1" FLANGE TEE POLY
19	3	520141	2.31/2.62 T-BOLT HOSE CLAMP SS
20	2	500058	2"NPT X 2" H BARB, POLY
21	1	601450	HOSE, 2 X 84 2F-1W EPDM
22	2	520056	HOSE CLAMP NO 56 STAINLESS
23	2	470118	1/4UNC X 3/4 FLANGE HEX BOLT
24	1	690529	RFM 100 FLOW METER, RAVEN
25	1	601451	HOSE, 2 X 69 2F-1W EPDM
26	1	500224	2" FLANGE PLUG W/1/2"FNPT POLY
27	1	500226	1" FLANGE PLUG W/1/4"FNPT POLY
28	1	618556	1/4NPT-90-1/2 HOSE BARB,POLY
29	3	696273	VALVE,REPLCMNT SECT FOR 696266
30	4	696254	O-RING, KZCO FLANGED VALVES

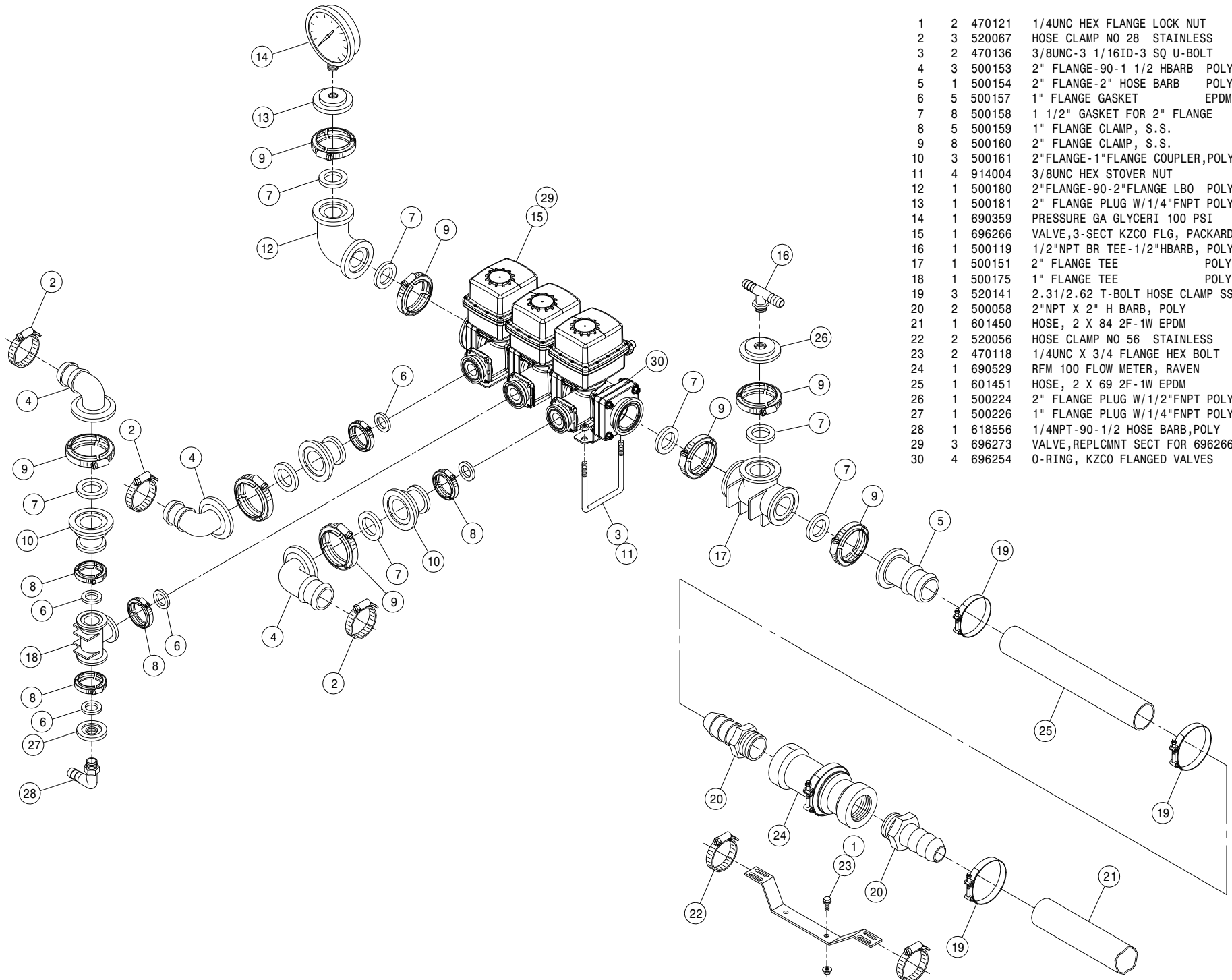

80'-90' SOLUTION SOLENOID (HI-VOLUME)

DET. QTY PART NO. DESCRIPTION

DET.	QTY	PART NO.	DESCRIPTION
1	2	470121	1/4UNC HEX FLANGE LOCK NUT
2	5	520067	HOSE CLAMP NO 28 STAINLESS
3	2	500151	2" FLANGE TEE POLY
4	3	500153	2" FLANGE-90-1 1/2 HBARB POLY
5	1	500154	2" FLANGE-2" HOSE BARB POLY
6	5	500157	1" FLANGE GASKET EPDM
7	10	500158	1 1/2" GASKET FOR 2" FLANGE
8	5	500159	1" FLANGE CLAMP, S.S.
9	10	500160	2" FLANGE CLAMP, S.S.
10	3	500161	2"FLANGE-1"FLANGE COUPLER,POLY
11	2	500162	2" FLANGE-1 1/2 HOSE BARB POLY
12	1	500180	2"FLANGE-90-2"FLANGE LBO POLY
13	1	500181	2" FLANGE PLUG W/1/4"FNPT POLY
14	1	690359	PRESSURE GA GLYCERI 100 PSI
15	1	696266	VALVE,3-SECT KZCO FLG, PACKARD
16	1	500175	1" FLANGE TEE POLY
17	1	500226	1" FLANGE PLUG W/1/4"FNPT POLY
18	1	618556	1/4NPT-90-1/2 HOSE BARB,POLY
19	3	520141	2.31/2.62 T-BOLT HOSE CLAMP SS
20	2	500058	2"NPT X 2" H BARB, POLY
21	1	601450	HOSE, 2 X 84 2F-1W EPDM
22	2	520056	HOSE CLAMP NO 56 STAINLESS
23	2	470118	1/4UNC X 3/4 FLANGE HEX BOLT
24	1	690529	RFM 100 FLOW METER, RAVEN
25	1	601451	HOSE, 2 X 69 2F-1W EPDM
26	2	470136	3/8UNC-3 1/16ID-3 SQ U-BOLT
27	4	914004	3/8UNC HEX STOVER NUT
28	3	696273	VALVE,REPLCMNT SECT FOR 696266
29	4	696254	O-RING, KZCO FLANGED VALVES

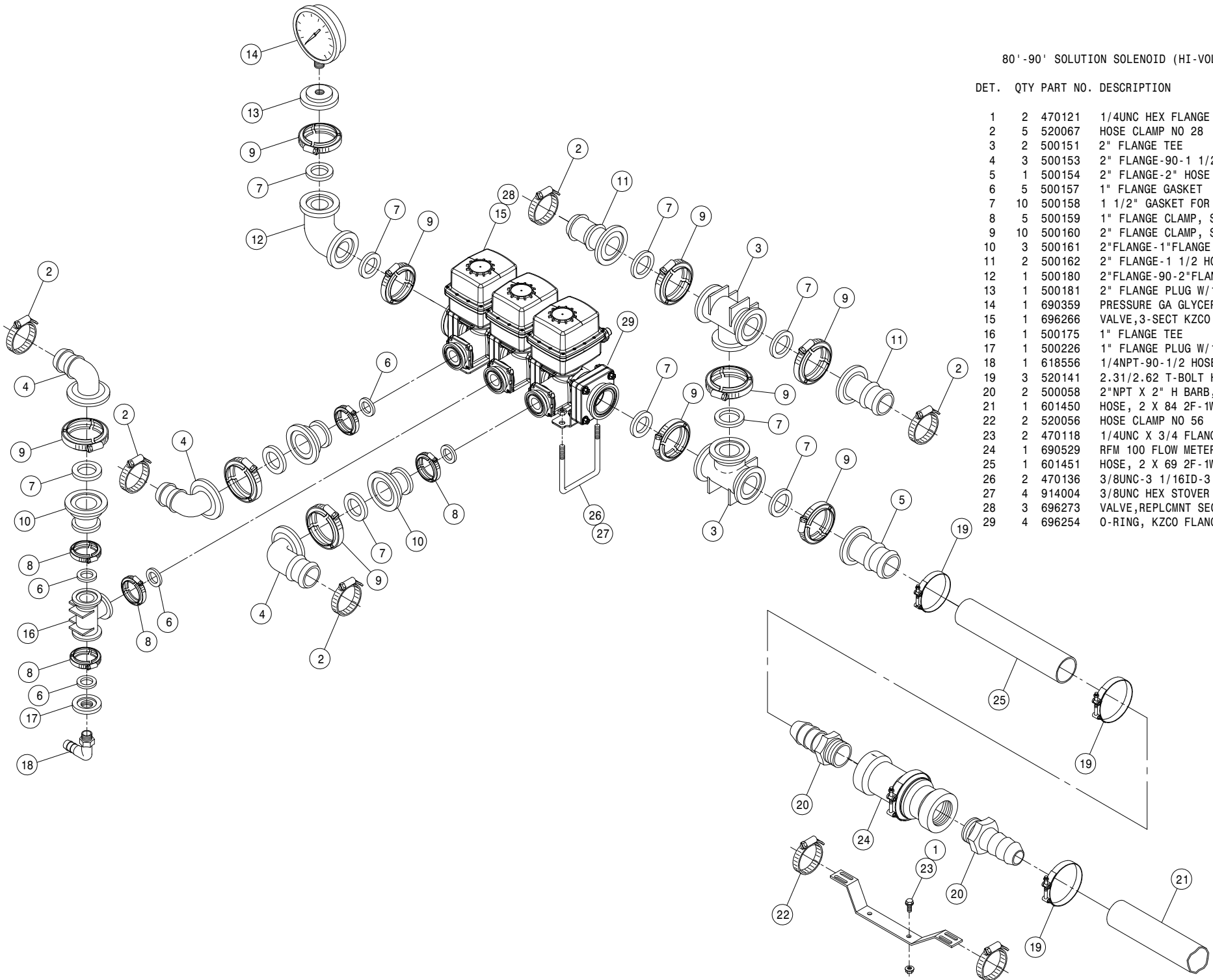

RH 80' -90' OUTER BOOM VALVE (HI-VOLUME)

DET. QTY PART NO. DESCRIPTION

1	4	500157	1" FLANGE GASKET	EPDM
2	4	500059	1 1/2"NPT X 2" HOSE BARB,POLY	
3	1	500162	2" FLANGE-1 1/2 HOSE BARB POLY	
4	1	500173	1" FLANGE-90-1" HOSE BARB POLY	
5	1	696282	VALVE,KZCO C2E 1"FLG ELEC W/WP	
6	1	500158	1 1/2" GASKET FOR 2" FLANGE	
7	1	500160	2" FLANGE CLAMP, S.S.	
8	1	500161	2"FLANGE-1"FLANGE COUPLER,POLY	
9	1	520067	HOSE CLAMP NO 28 STAINLESS	
10	1	500175	1" FLANGE TEE	POLY
11	1	500226	1" FLANGE PLUG W/1/4"FNPT POLY	
12	1	618556	1/4NPT-90-1/2 HOSE BARB,POLY	
13	1	520090	HOSE CLAMP NO 16 STAINLESS	
14	2	470121	1/4UNC HEX FLANGE LOCK NUT	
15	2	470118	1/4UNC X 3/4 FLANGE HEX BOLT	

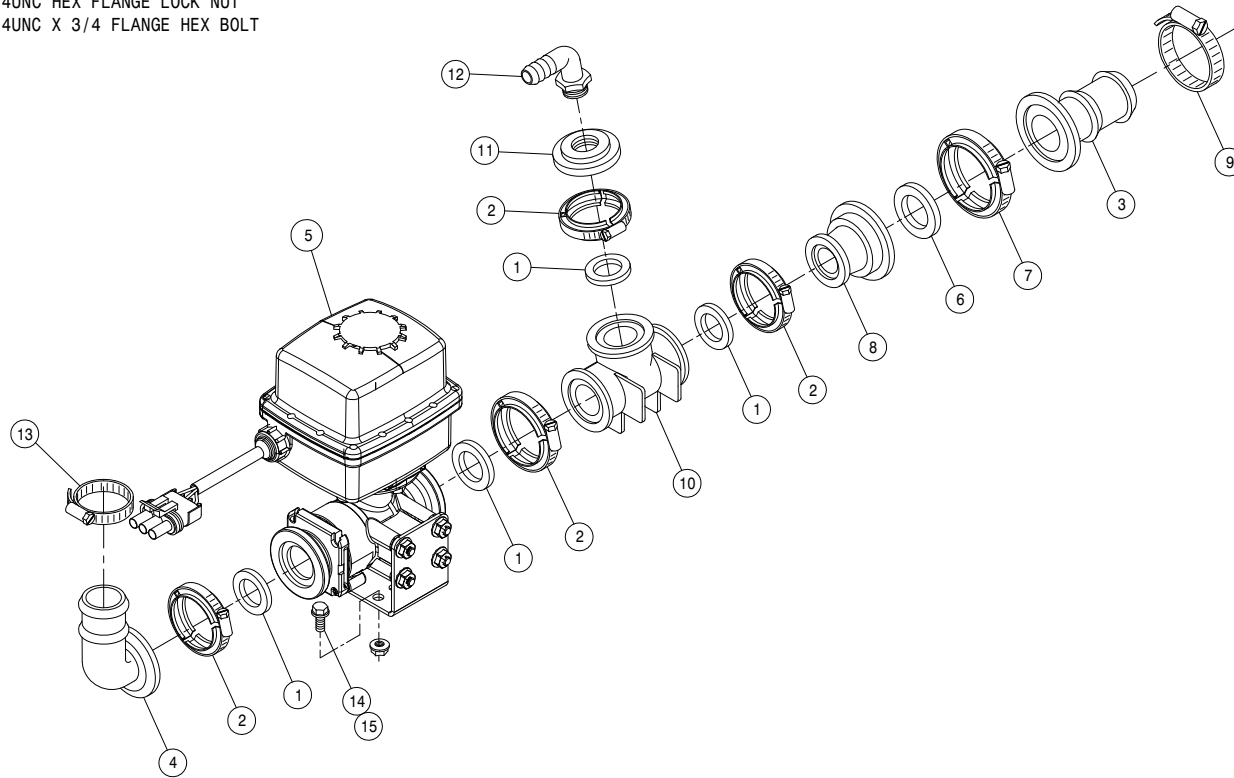

LH 80' -90' OUTER BOOM VALVE (HI-VOLUME)

DET. QTY PART NO. DESCRIPTION

1	4	500157	1" FLANGE GASKET	EPDM
2	4	500159	1" FLANGE CLAMP, S.S.	
3	1	500162	2" FLANGE-1 1/2 HOSE BARB POLY	
4	1	500173	1" FLANGE-90-1" HOSE BARB POLY	
5	1	696282	VALVE,KZCO C2E 1"FLG ELEC W/WP	
6	1	500158	1 1/2" GASKET FOR 2" FLANGE	
7	1	500160	2" FLANGE CLAMP, S.S.	
8	1	500161	2"FLANGE-1"FLANGE COUPLER,POLY	
9	1	520067	HOSE CLAMP NO 28 STAINLESS	
10	1	500175	1" FLANGE TEE	POLY
11	1	500226	1" FLANGE PLUG W/1/4"FNPT POLY	
12	1	618556	1/4NPT-90-1/2 HOSE BARB,POLY	
13	1	520090	HOSE CLAMP NO 16 STAINLESS	
14	2	470121	1/4UNC HEX FLANGE LOCK NUT	
15	2	470118	1/4UNC X 3/4 FLANGE HEX BOLT	

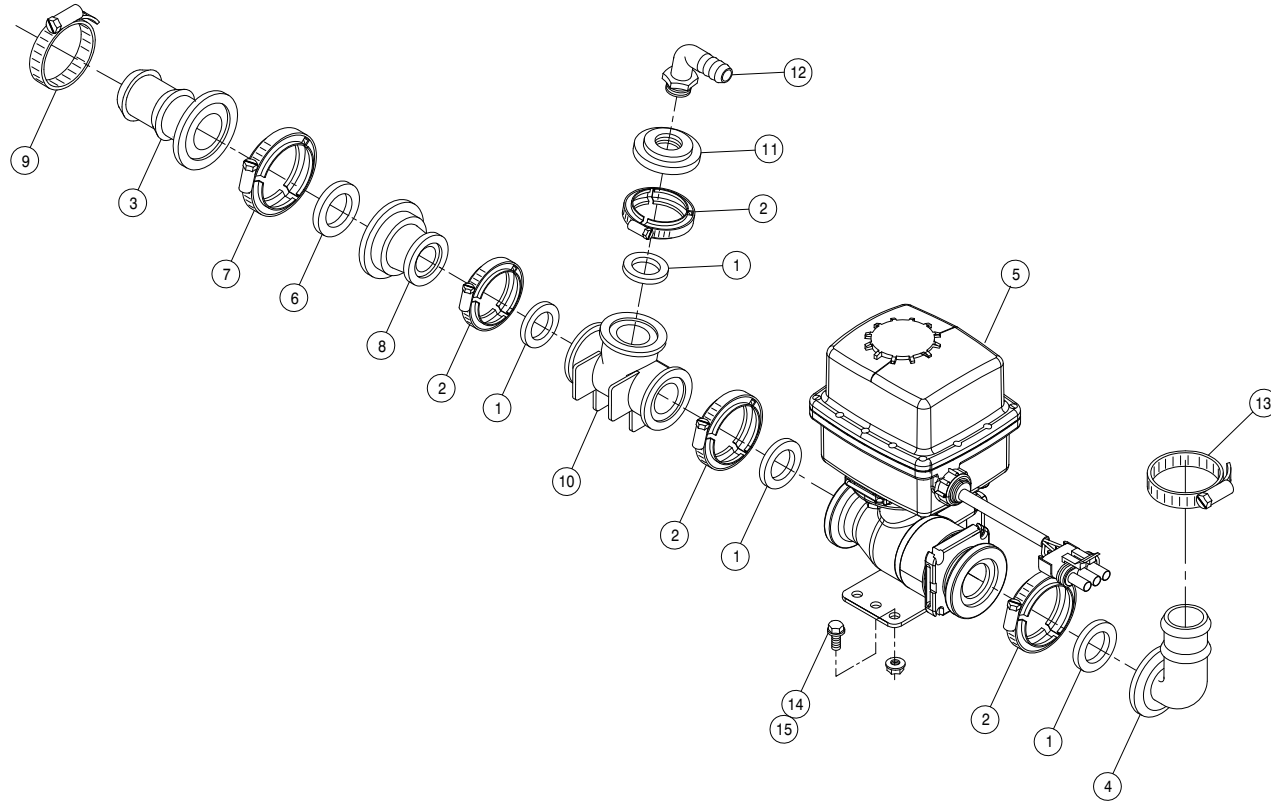

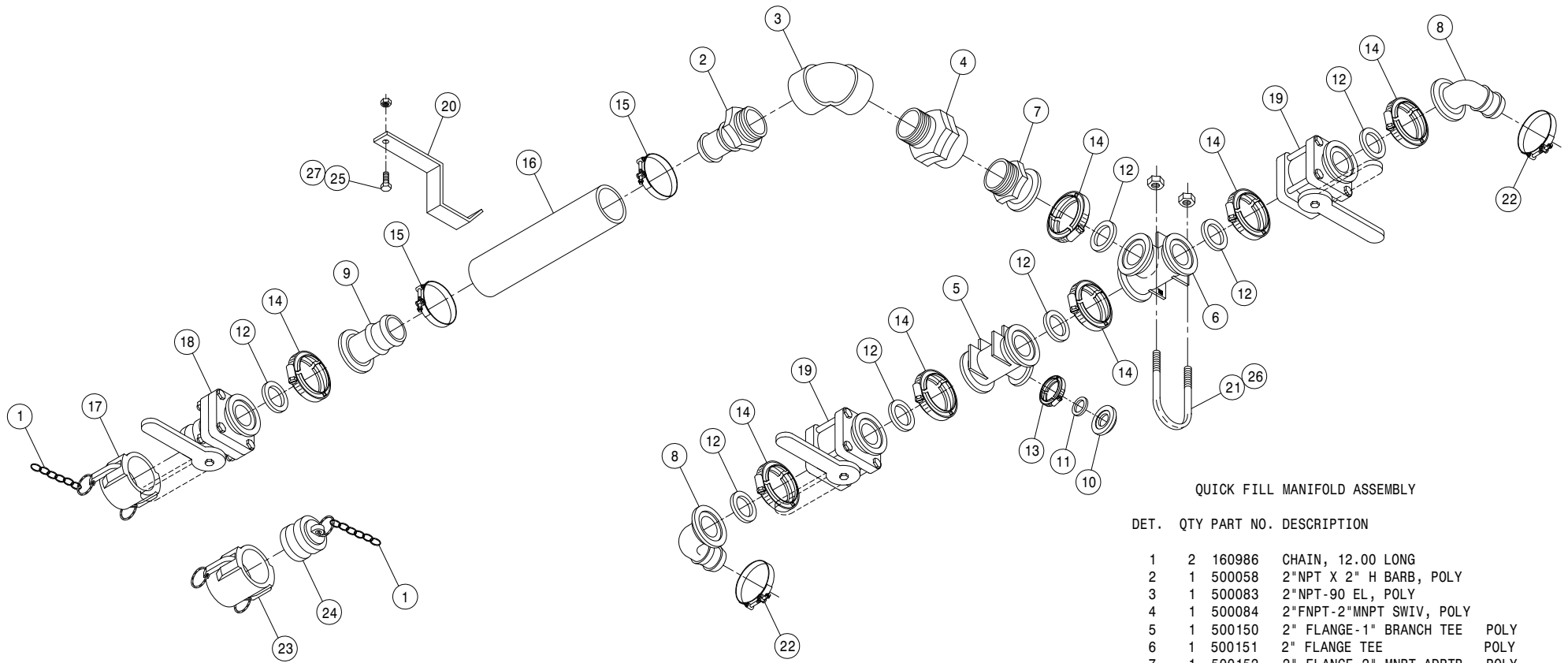

QUICK FILL MANIFOLD ASSEMBLY

DET. QTY PART NO. DESCRIPTION

1	2	160986	CHAIN, 12.00 LONG
2	1	500058	2"NPT X 2" H BARB, POLY
3	1	500083	2"NPT-90 EL, POLY
4	1	500084	2"FNPT-2"MNPT SWIV, POLY
5	1	500150	2" FLANGE-1" BRANCH TEE POLY
6	1	500151	2" FLANGE TEE POLY
7	1	500152	2" FLANGE-2" MNPT ADPTR POLY
8	2	500153	2" FLANGE-90-1 1/2 HBARB POLY
9	1	500154	2" FLANGE-2" HOSE BARB POLY
10	1	500155	1" FLANGE CAP PLUG POLY
11	1	500157	1" FLANGE GASKET EPDM
12	7	500158	1 1/2" GASKET FOR 2" FLANGE
13	1	500159	1" FLANGE CLAMP, S.S.
14	7	500160	2" FLANGE CLAMP, S.S.
15	2	520141	2.31/2.62 T-BOLT HOSE CLAMP SS
16	1	601438	HOSE, 2 X 10 2F-1W EPDM
17	1	690623	CAP FOR 2.00 MALE COUPLER POLY
18	1	696141	BALL VLV, 2"FLANGE/2"MALE ADPTR
19	2	696142	BALL VLV, 2" FLANGE
20	1	342620	QUICK FILL HOSE HANGER
21	2	472195	5/16UNC-2 11/16ID-3 9/16U-BOLT
22	2	520133	1.81/2.06 T-BOLT HOSE CLAMP SS
23	1	690390	2.00FNPT-FEMALE COUPLER POLY
24	1	690392	PLUG FOR 2.00 FEMALE COUPLER
25	1	900129	3/8UNC X 1" SERR FLANGE BOLT
26	4	914002	5/16UNC HEX STOVER NUT
27	1	914004	3/8UNC HEX STOVER NUT

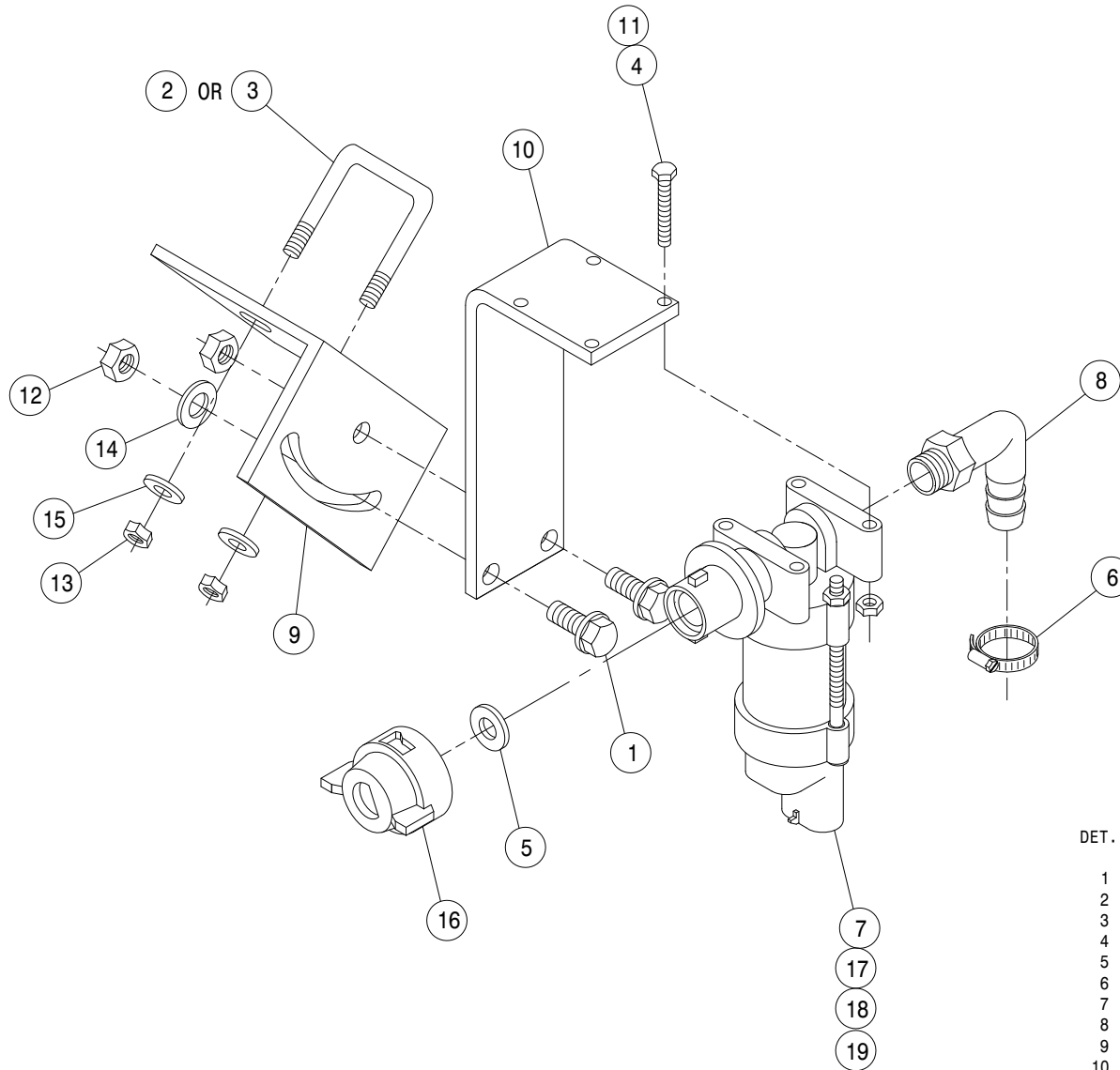

RIGHT FENCE ROW NOZZLE ASSEMBLY

DET.	QTY	PART NO.	DESCRIPTION
	1	2 470118	1/4UNC X 3/4 FLANGE HEX BOLT
	2	1 473973	5/16UNC-1 5/16ID-2"SQ U-BOLTSS
	3	1 473980	.31UNC-1.06ID-1.75SQ U-BOLT SS
	4	4 473993	6-32 X 1 1/4 HH MACH SCR
	5	1 737824	QUICK TEEJET SEAT GASKET
	6	1 520070	HOSE CLAMP NO 8 STAINLESS
	7	1 737875	NOZZLE BODY VALVE, 12VDC
	8	1 618556	1/4NPT-90-1/2 HOSE BARB,POLY
	9	1 737886	FENCE-ROW NOZZLE MT,284 01
	10	1 737906	FENCE ROW NOZL BRKT
	11	4 910022	6-32 HEX NUT
	12	2 914000	1/4UNC HEX STOVER NUT
	13	2 914002	5/16UNC HEX STOVER NUT
	14	1 920000	1/4 SAE FLAT WASHER
	15	2 920001	5/16 SAE FLAT WASHER
	16	1 737822	CAP SET, YELLOW QUICK TEEJET
	17	1 737877	.75 ELECT FENCE ROW NOZL ASSY
	18	1 737888	O-RING, .014 VITON, VLV 737875
	19	1 737889	VALVE BODY, .148ORIF,VLV 737875

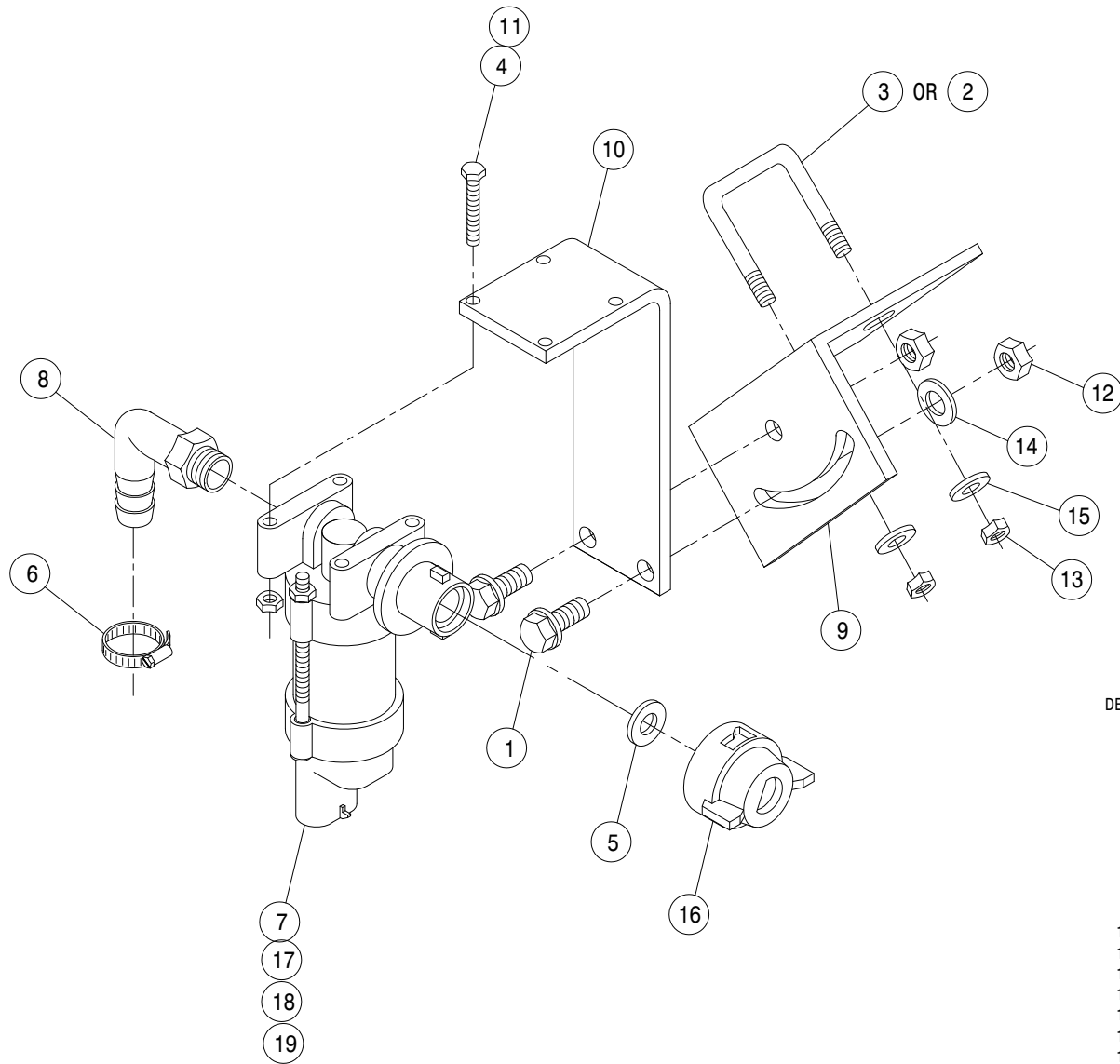

LEFT FENCE ROW NOZZLE ASSEMBLY

DET.	QTY	PART NO.	DESCRIPTION
	1	2	470118 1/4UNC X 3/4 FLANGE HEX BOLT
	1	2	473973 5/16UNC-1 5/16ID-2"SQ U-BOLTSS
	1	3	473980 .31UNC-1.06ID-1.75SQ U-BOLT SS
	4	4	473993 6-32 X 1 1/4 HH MACH SCR
	1	5	737824 QUICK TEEJET SEAT GASKET
	1	6	520070 HOSE CLAMP NO 8 STAINLESS
	1	7	737875 NOZZLE BODY VALVE, 12VDC
	1	8	618556 1/4NPT-90-1/2 HOSE BARB,POLY
	1	9	737886 FENCE-ROW NOZZLE MT,284 01
	1	10	737906 FENCE ROW NOZL BRKT
	4	11	910022 6-32 HEX NUT
	2	12	914000 1/4UNC HEX STOVER NUT
	2	13	914002 5/16UNC HEX STOVER NUT
	1	14	920000 1/4 SAE FLAT WASHER
	2	15	920001 5/16 SAE FLAT WASHER
	1	16	737822 CAP SET, YELLOW QUICK TEEJET
	1	17	737887 PLUNGER W/SEAT, VLV 737875
	1	18	737888 O-RING, .014 VITON, VLV 737875
	1	19	737889 VALVE BODY, .148ORIF,VLV 737875

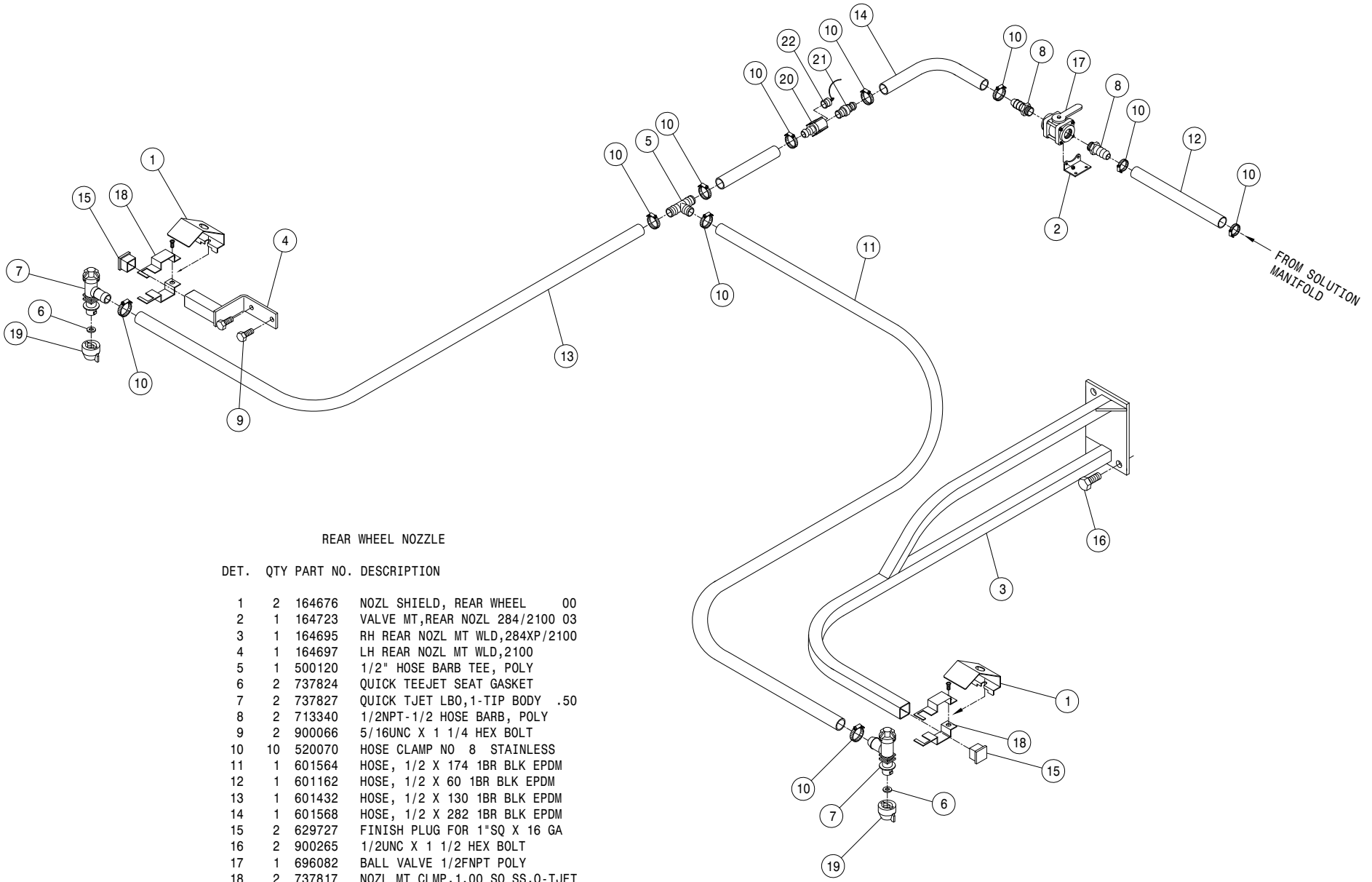

REAR WHEEL NOZZLE

DET.	QTY	PART NO.	DESCRIPTION
1	2	164676	NOZL SHIELD, REAR WHEEL 00
2	1	164723	VALVE MT,REAR NOZL 284/2100 03
3	1	164695	RH REAR NOZL MT WLD,284XP/2100
4	1	164697	LH REAR NOZL MT WLD,2100
5	1	500120	1/2" HOSE BARB TEE, POLY
6	2	737824	QUICK TEEJET SEAT GASKET
7	2	737827	QUICK TJET LBO,1-TIP BODY .50
8	2	713340	1/2NPT-1/2 HOSE BARB, POLY
9	2	900066	5/16UNC X 1 1/4 HEX BOLT
10	10	520070	HOSE CLAMP NO 8 STAINLESS
11	1	601564	HOSE, 1/2 X 174 1BR BLK EPDM
12	1	601162	HOSE, 1/2 X 60 1BR BLK EPDM
13	1	601432	HOSE, 1/2 X 130 1BR BLK EPDM
14	1	601568	HOSE, 1/2 X 282 1BR BLK EPDM
15	2	629727	FINISH PLUG FOR 1"SQ X 16 GA
16	2	900265	1/2UNC X 1 1/2 HEX BOLT
17	1	696082	BALL VALVE 1/2FNPT POLY
18	2	737817	NOZL MT CLMP,1.00 SQ SS,Q-TJET
19	2	737822	CAP SET, YELLOW QUICK TEEJET
20	1	696233	.50 HOSE BARB-FEMALE COUPLER
21	1	696234	.50 HOSE BARB-MALE COUPLER
22	1	696204	PLUG FOR .50/.75 FEM COUPLER

SOLUTION HOISING FOR 60' BOOM (STANDARD)

DET. QTY PART NO. DESCRIPTION

DET.	QTY	PART NO.	DESCRIPTION
1	1	601451	HOSE, 2 X 69 2F-1W EPDM
2	1	601428	HOSE, 1 1/2 X 125 2F-1W EPDM
3	1	601429	HOSE, 1 1/2 X 143 2F-1W EPDM
4	2	601430	HOSE, 1 1/2 X 183 2F-1W EPDM
5	1	601456	HOSE, 3/4 X 117 1BR BLK EPDM
6	1	601457	HOSE, 3/4 X 130 1BR BLK EPDM
7	1	601425	HOSE, 1 X 192 2F-1W EPDM
8	1	601450	HOSE, 2 X 84 2F-1W EPDM
9	1	601438	HOSE, 2 X 10 2F-1W EPDM
10	2	690412	HOSE SPRING GUARD 2IN X 12 LG
11	1	601458	HOSE, 1 X 51 1BR BLK EPDM
12	1	601460	HOSE, 1 X 248 1BR BLK EPDM
13	1	601461	HOSE, 1 X 262 1BR BLK EPDM
14	2	342635	NYL HOSE SLEEVE, 2.64ID X 60.00
15	3	342638	NYL HOSE SLEEVE, 2.96ID X 65.00
16	2	601571	HOSE, 1/2 X 420 1BR BLK EPDM

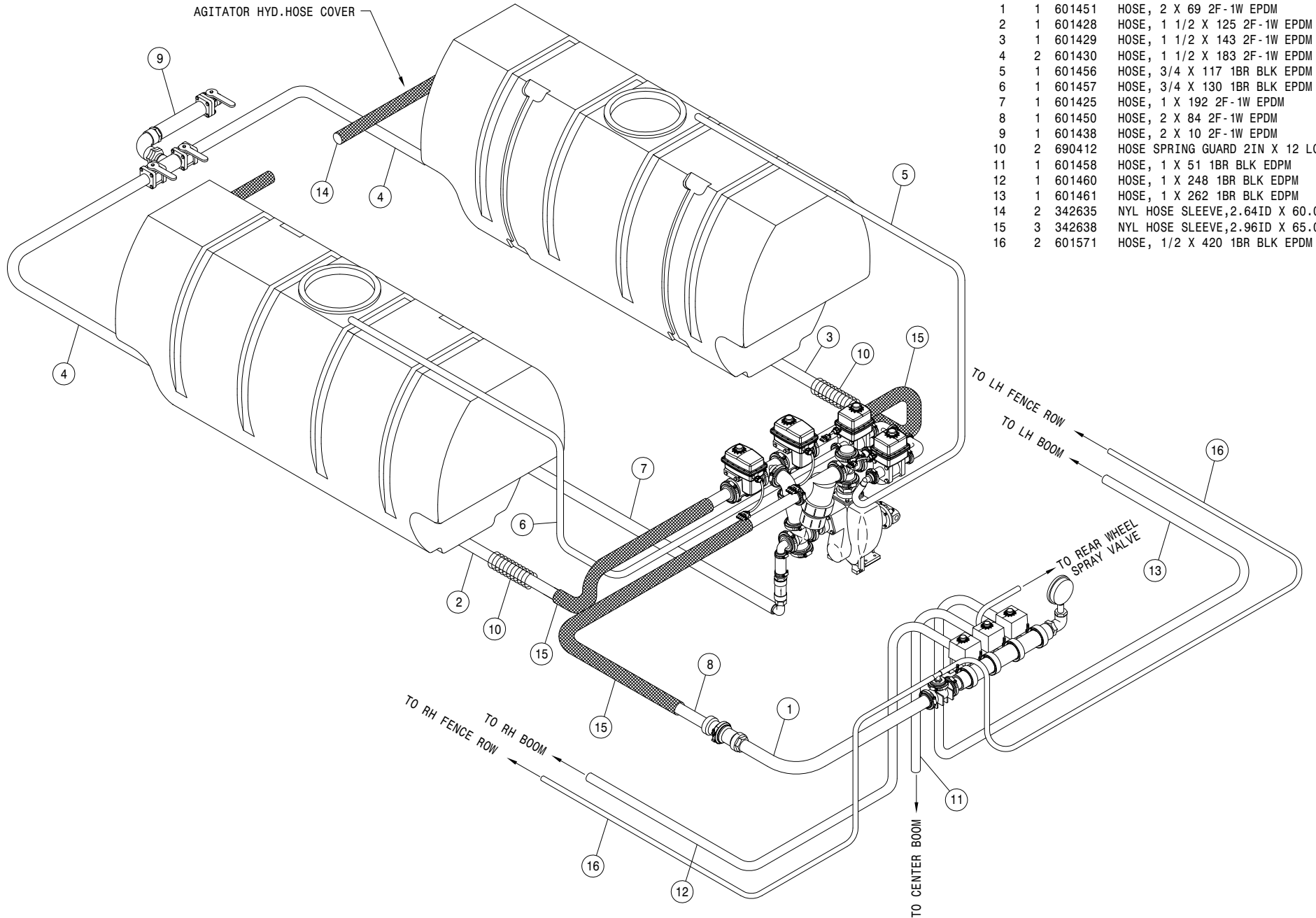

AGITATOR HYD. HOSE COVER

9

14

4

5

4

3

10

15

7

6

2

10

15

8

15

1

11

TO RH FENCE ROW
TO RH BOOM

TO LH FENCE ROW
TO LH BOOM

TO REAR WHEEL
SPRAY VALVE

TO CENTER BOOM

16

12

13

16

SOLUTION HOISING FOR 80' -90' BOOM (STANDARD)

DET. QTY PART NO. DESCRIPTION

DET.	QTY	PART NO.	DESCRIPTION
1	1	601451	HOSE, 2 X 69 2F-1W EPDM
2	1	601428	HOSE, 1 1/2 X 125 2F-1W EPDM
3	1	601429	HOSE, 1 1/2 X 143 2F-1W EPDM
4	2	601430	HOSE, 1 1/2 X 183 2F-1W EPDM
5	1	601456	HOSE, 3/4 X 117 1BR BLK EPDM
6	1	601457	HOSE, 3/4 X 130 1BR BLK EPDM
7	1	601425	HOSE, 1 X 192 2F-1W EPDM
8	1	601450	HOSE, 2 X 84 2F-1W EPDM
9	1	601438	HOSE, 2 X 10 2F-1W EPDM
10	2	690412	HOSE SPRING GUARD 2IN X 12 LG
11	1	601458	HOSE, 1 X 51 1BR BLK EDPM
12	1	601460	HOSE, 1 X 248 1BR BLK EDPM
13	1	601461	HOSE, 1 X 262 1BR BLK EDPM
14	2	342635	NYL HOSE SLEEVE, 2.64ID X 60.00
15	3	342638	NYL HOSE SLEEVE, 2.96ID X 65.00
16	2	601570	HOSE, 1/2 X 236 1BR BLK EPDM
17	2	601167	HOSE, 1/2 X 300 1BR BLK EPDM
18	2	601390	HOSE, 1 X 160 1BR BLK EPDM
19	1	601459	HOSE, 1 X 245 1BR BLK EDPM
20	1	601462	HOSE, 1 X 294 1BR BLK EDPM

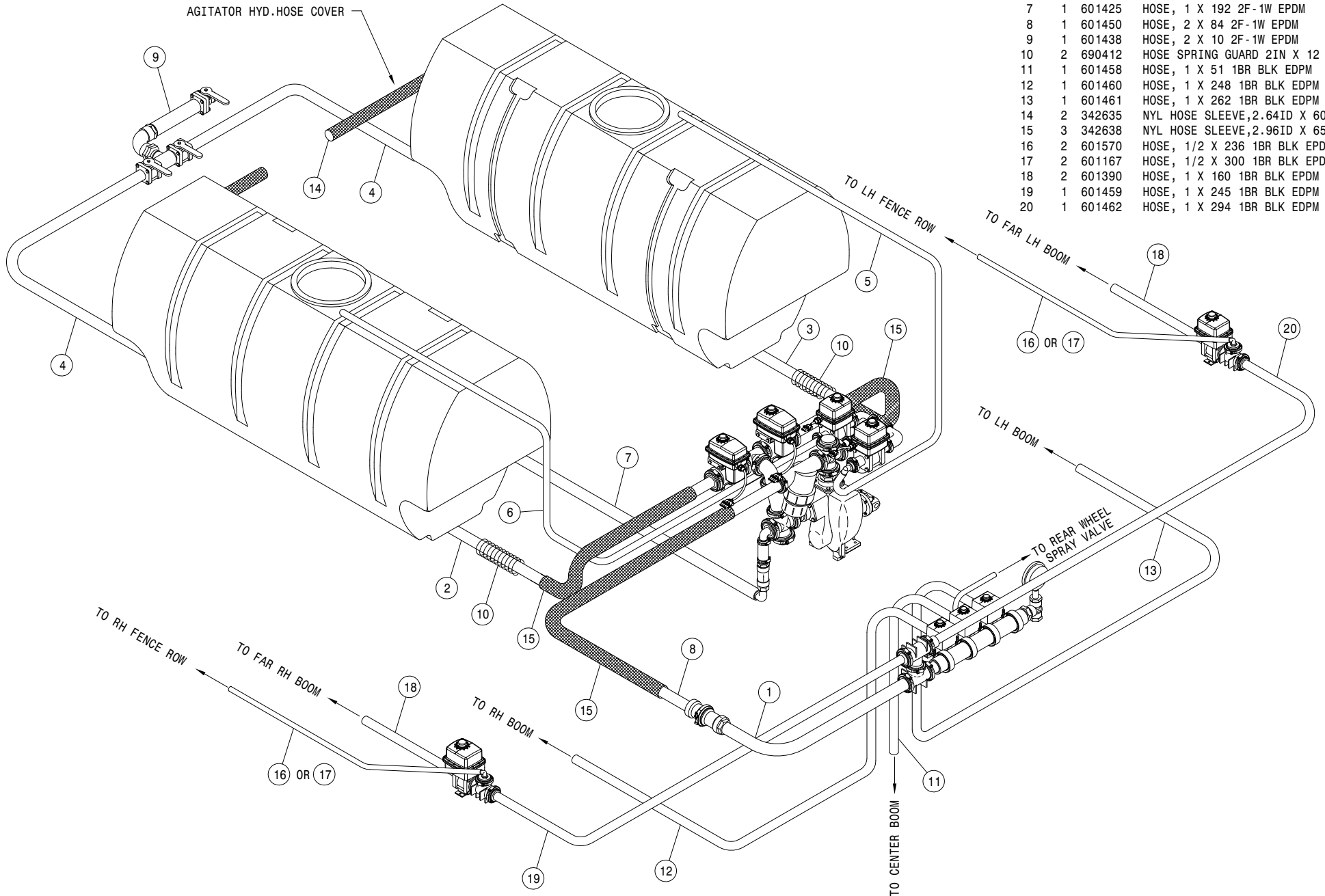

SOLUTION HOISING FOR 60' BOOM (HI-VOLUME)

DET. QTY PART NO. DESCRIPTION

1	1	601451	HOSE, 2 X 69 2F-1W EPDM
2	1	601428	HOSE, 1 1/2 X 125 2F-1W EPDM
3	1	601429	HOSE, 1 1/2 X 143 2F-1W EPDM
4	2	601430	HOSE, 1 1/2 X 183 2F-1W EPDM
5	1	601456	HOSE, 3/4 X 117 1BR BLK EPDM
6	1	601457	HOSE, 3/4 X 130 1BR BLK EPDM
7	1	601425	HOSE, 1 X 192 2F-1W EPDM
8	1	601450	HOSE, 2 X 84 2F-1W EPDM
9	1	601438	HOSE, 2 X 10 2F-1W EPDM
10	2	690412	HOSE SPRING GUARD 2IN X 12 LG
11	1	601538	HOSE, 1 1/2 X 51 2BR BLK EPDM
12	1	601540	HOSE, 1 1/2 X 248 2BR BLK EPDM
13	1	601541	HOSE, 1 1/2 X 262 2BR BLK EPDM
14	2	342635	NYL HOSE SLEEVE, 2.64ID X 60.00
15	3	342638	NYL HOSE SLEEVE, 2.96ID X 65.00
16	2	601571	HOSE, 1/2 X 420 1BR BLK EPDM

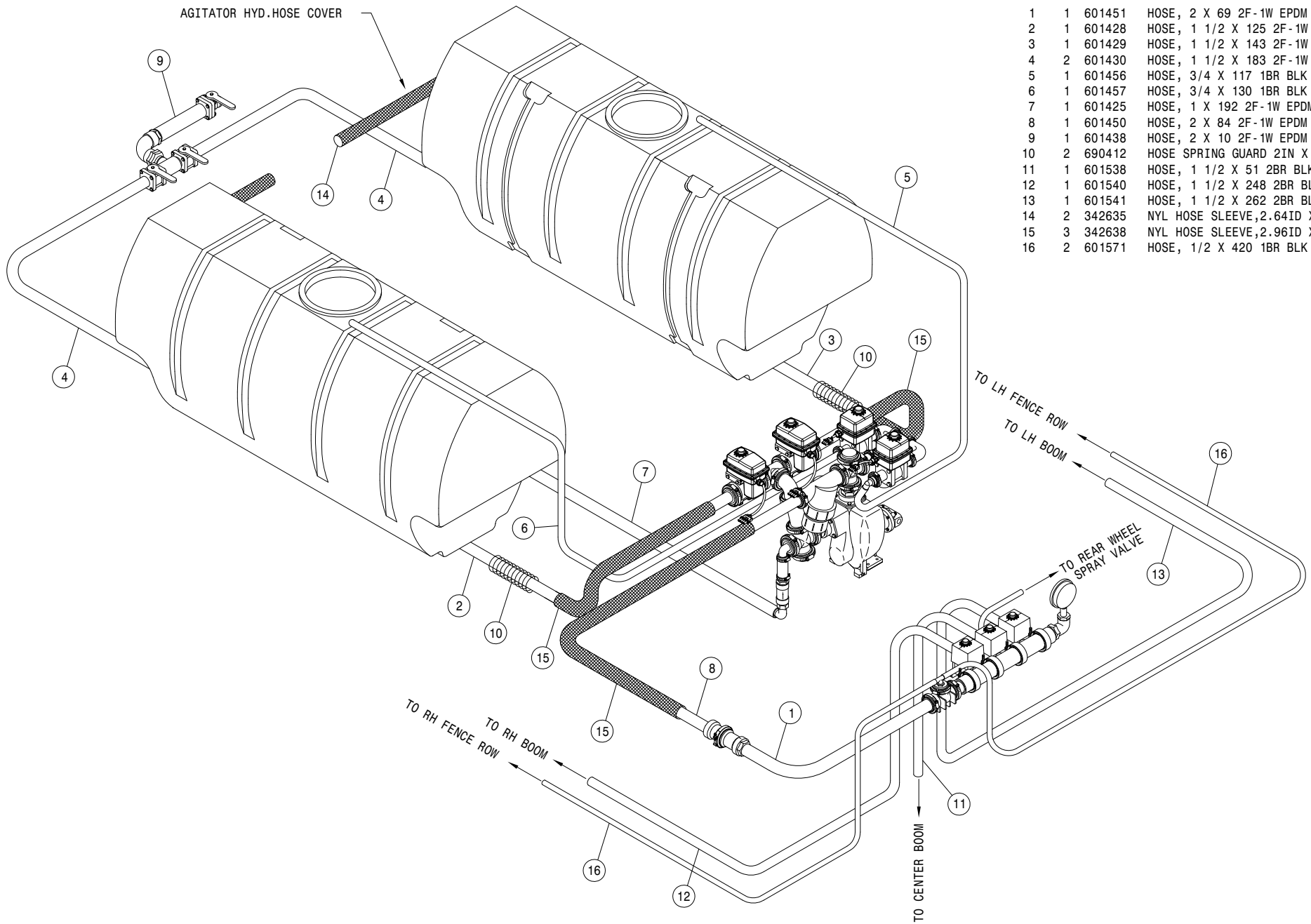

SOLUTION HOISING FOR 80'-90' BOOM (HI-VOLUME)

DET. QTY PART NO. DESCRIPTION

DET.	QTY	PART NO.	DESCRIPTION
1	1	601451	HOSE, 2 X 69 2F-1W EPDM
2	1	601428	HOSE, 1 1/2 X 125 2F-1W EPDM
3	1	601429	HOSE, 1 1/2 X 143 2F-1W EPDM
4	2	601430	HOSE, 1 1/2 X 183 2F-1W EPDM
5	1	601456	HOSE, 3/4 X 117 1BR BLK EPDM
6	1	601457	HOSE, 3/4 X 130 1BR BLK EPDM
7	1	601425	HOSE, 1 X 192 2F-1W EPDM
8	1	601450	HOSE, 2 X 84 2F-1W EPDM
9	1	601438	HOSE, 2 X 10 2F-1W EPDM
10	2	690412	HOSE SPRING GUARD 2IN X 12 LG
11	1	601538	HOSE, 1 1/2 X 51 2BR BLK EPDM
12	1	601540	HOSE, 1 1/2 X 248 2BR BLK EPDM
13	1	601541	HOSE, 1 1/2 X 262 2BR BLK EPDM
14	2	342635	NYL HOSE SLEEVE, 2.64ID X 60.00
15	3	342638	NYL HOSE SLEEVE, 2.96ID X 65.00
16	2	601570	HOSE, 1/2 X 236 1BR BLK EPDM
17	2	601167	HOSE, 1/2 X 300 1BR BLK EPDM
18	2	601390	HOSE, 1 X 160 1BR BLK EPDM
19	1	601539	HOSE, 1 1/2 X 245 2BR BLK EPDM
20	1	601542	HOSE, 1 1/2 X 294 2BR BLK EPDM

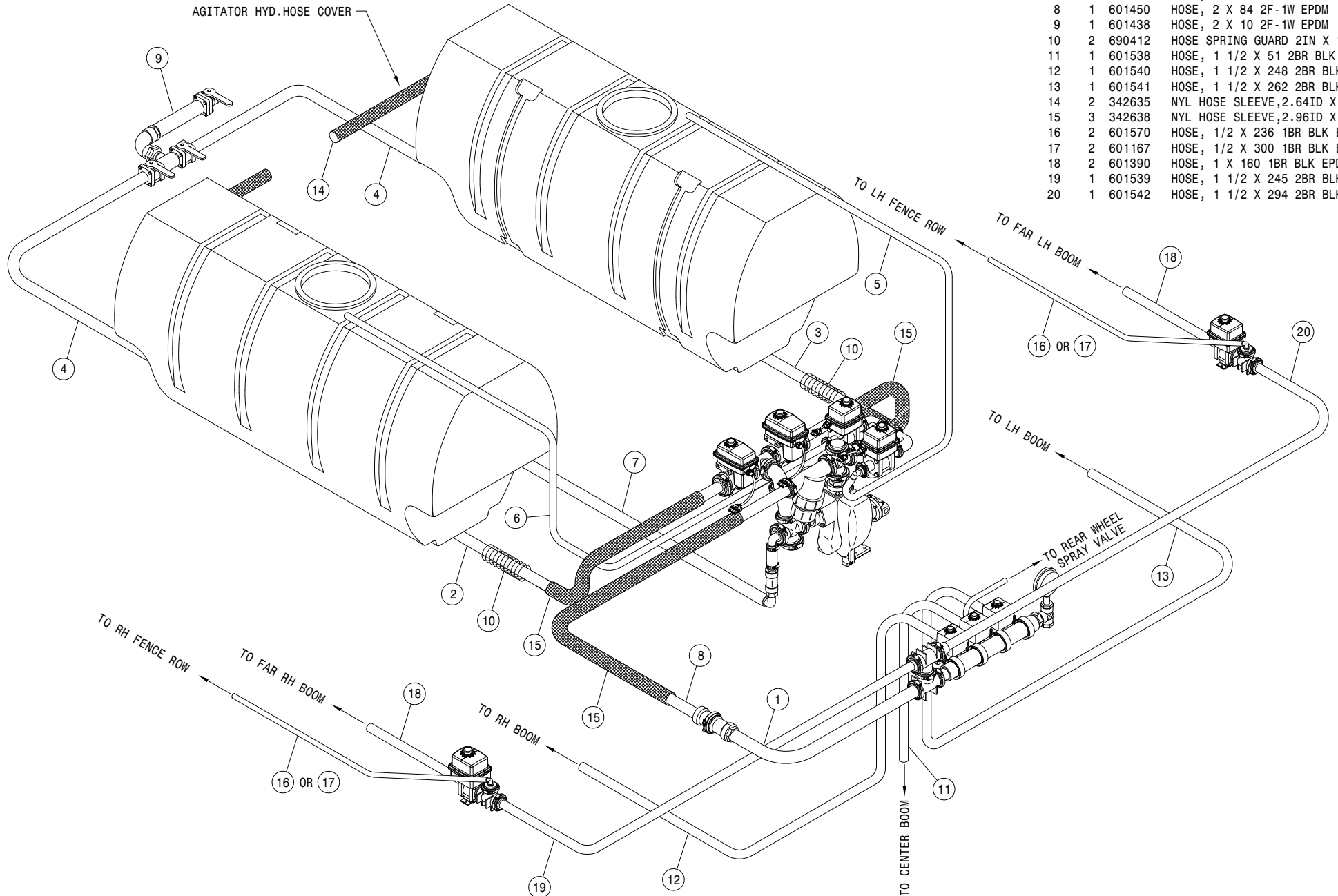

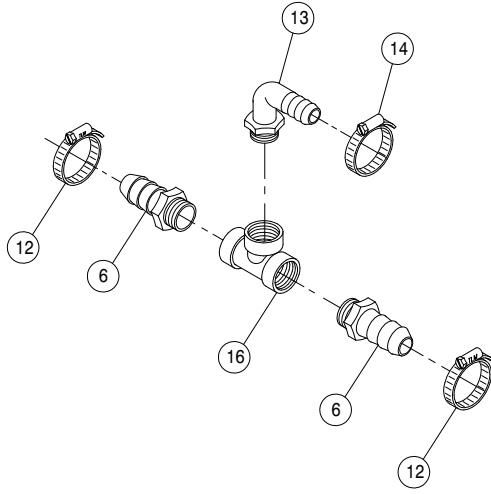

FEEDER TEE ASSEMBLY (STANDARD VOLUME)

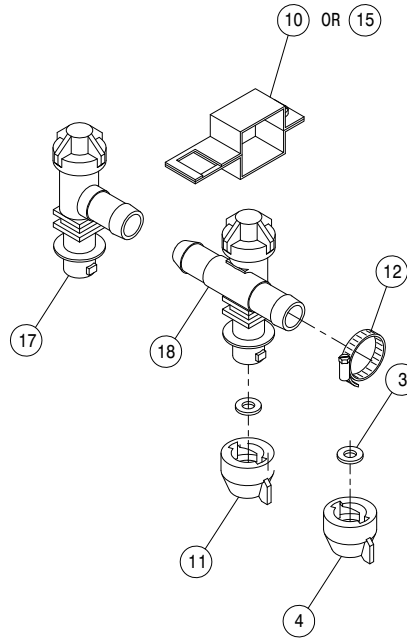

SINGLE TIP NOZZLE SPACING

BOOM FEEDER TEE ASSEMBLY

DET.	QTY	PART NO.	DESCRIPTION
1	2	500108	1"NPT-3/4" HOSE BARB POLY
2	1	500117	1"NPT-90-1 1/2"HOSE BARB, POLY
3	4	737824	QUICK TEEJET SEAT GASKET
4	2	737825	QUICK SHUT-OFF CAP
5	1	520067	HOSE CLAMP NO 28 STAINLESS
6	2	500022	3/4NPT-3/4HOSE BARB, POLY
7	1	500075	1" NPT PIPE TEE, POLY
8	1	737833	QUICK TJET LBO,3-TIP BODY .75
9	1	737834	QUICK TJET TEE,3-TIP BODY .75
10	2	737817	NOZL MT CLMP,1.00 SQ SS,Q-TJET
11	2	737822	CAP SET, YELLOW QUICK TEEJET
12	6	520055	HOSE CLAMP NO 12 STAINLESS
13	1	500026	3/4NPT-90-1"HOSE BARB, POLY
14	1	520090	HOSE CLAMP NO 16 STAINLESS
15	2	737832	NOZL MT CLMP,1.25 SQ,SS Q-TJET
16	1	505218	3/4 NPT PIPE TEE, POLY
17	1	737829	QUICK TJET LBO,1-TIP BODY .75
18	1	737830	QUICK TJET TEE,1-TIP BODY .75

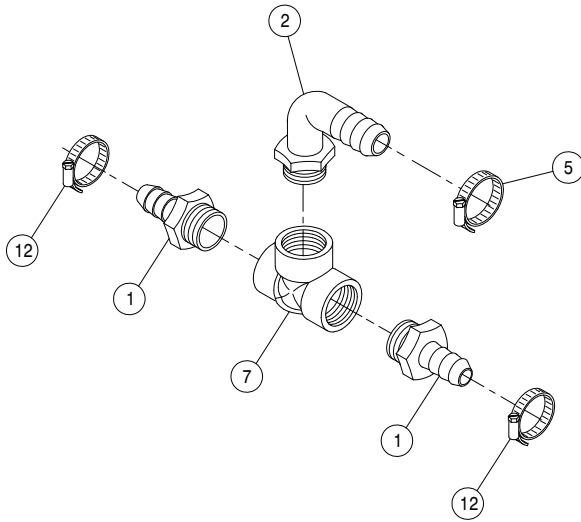

FEEDER TEE ASSEMBLY (HIGH VOLUME)

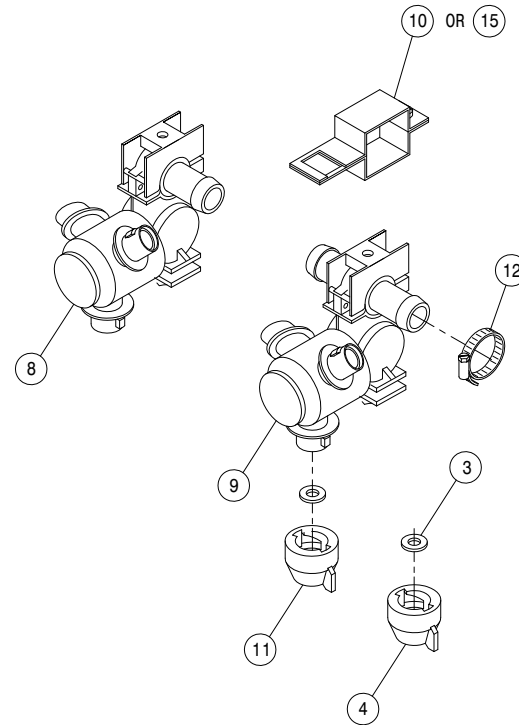

TRIPLE TIP NOZZLE SPACING

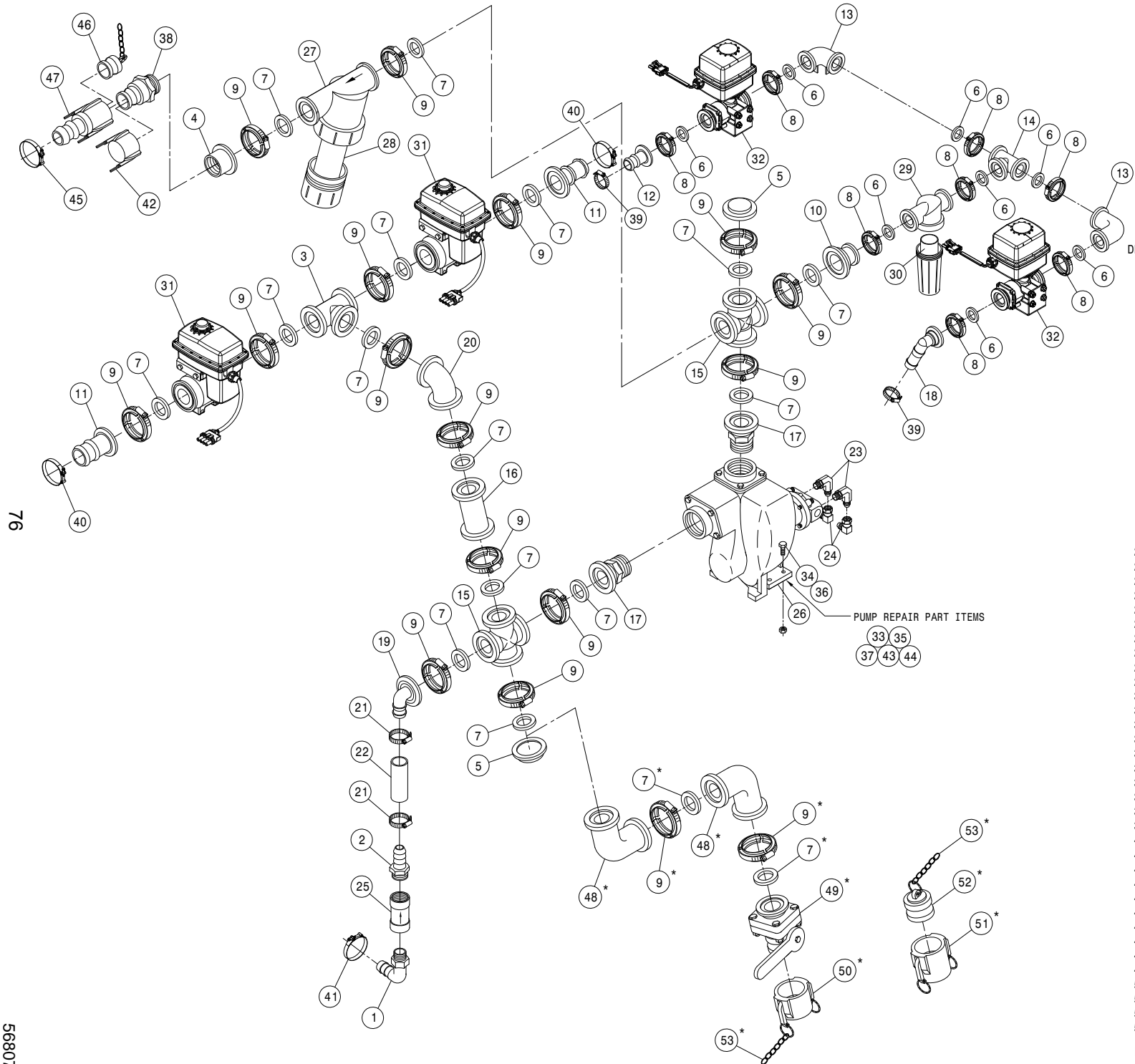

SOLUTION PUMP ASSEMBLY

DET.	QTY	PART NO.	DESCRIPTION
1	1	500024	1"NPT-90-1"HOSE BARB, POLY
2	1	500074	1"NPT-1" HOSE BARB, POLY
3	1	500151	2" FLANGE TEE POLY
4	1	500183	2" FLANGE-2" FNPT ADPTR POLY
5	2	500156	2" FLANGE CAP PLUG POLY
6	8	500157	1" FLANGE GASKET EPDM
7	17	500158	1 1/2" GASKET FOR 2" FLANGE
8	8	500159	1" FLANGE CLAMP, S.S.
9	17	500160	2" FLANGE CLAMP, S.S.
10	1	500161	2"FLANGE-1"FLANGE COUPLER,POLY
11	2	500162	2" FLANGE-1 1/2 HOSE BARB POLY
12	1	500170	1" FLANGE-3/4" HOSE BARB POLY
13	2	500174	1" FLANGE-90-1" FLANGE LBOPOLY
14	1	500175	1" FLANGE TEE POLY
15	2	500176	2" FLANGE CROSS POLY
16	1	500177	2" FLANGE-2" FLANGE CPLR POLY
17	2	500182	2" FLANGE-2"MNPT ADPTR S.S.
18	1	500185	1"FLANGE-90-3/4"HOSE BARB POLY
19	1	500189	2" FLANGE-90-1" HOSE BARB POLY
20	1	500225	2"FLANGE-45-2"FLANGE LBO POLY
21	2	520087	HOSE CLAMP NO 20 STAINLESS
22	1	601741	HOSE, 1 X 7 2BR BLK EPDM
23	2	618241	3/4MJIC-90-3/4MOR LBO
24	2	618609	3/4MJIC-90-3/4FJIC SWIV LBO
25	1	690488	1.00 CHECK VLV, SPRING LOADED
26	1	690552	FLOMAX 8, 2" PUMP
27	1	690628	LINE "Y" STRAINER, 2" FLANGE
28	1	690629	50 MESH SCREEN FOR 690628
29	1	690660	LINE T-STRAINER,1"FLG,W/O SCRIN
30	1	690661	50 MESH SCREEN FOR 690660
31	2	696265	VALVE,KZCO 2"SPF ELEC W/WP
32	2	696282	VALVE,KZCO C2E 1"FLG ELEC W/WP
33	1	690570	FLAPPER ASSY, BUNA, FLOMAX 8
34	4	900066	5/16UNC X 1 1/4 HEX BOLT
35	1	690571	WEAR PLATE, STEEL
36	4	914002	5/16UNC HEX STOVER NUT
37	1	690565	IMPELLER, CAST IRON 4.8DIA
38	1	696201	ADAPTER, 2IN MALE FOR 690390
39	2	520055	HOSE CLAMP NO 12 STAINLESS
40	2	520133	1.81/2.06 T-BOLT HOSE CLAMP SS
41	1	520138	1.38/1.56 T-BOLT HOSE CLAMP
42	1	690623	CAP FOR 2.00 MALE COUPLER POLY
43	1	695939	SEAL ASSY, VITON, FLOMAX PUMP
44	1	695919	GASKET FLOMAX PUMP
45	1	520141	2.31/2.62 T-BOLT HOSE CLAMP SS
46	1	690392	PLUG FOR 2.00 FEMALE COUPLER
47	1	696210	2.00 HOSE BARB-FEMALE COUPLER
48	2	500150	2" FLANGE-1" BRANCH TEE POLY
49	1	696141	BALL VLV,2"FLANGE/2"MALE ADPTR
50	1	690623	CAP FOR 2.00 MALE COUPLER POLY
51	1	690390	2.00FNPT-FEMALE COUPLER POLY
52	1	690392	PLUG FOR 2.00 FEMALE COUPLER
53	2	160986	CHAIN, 12.00 LONG

NOTE: ITEMS WITH A (*) ARE USE WITH THE FRONT FILL OPTION.

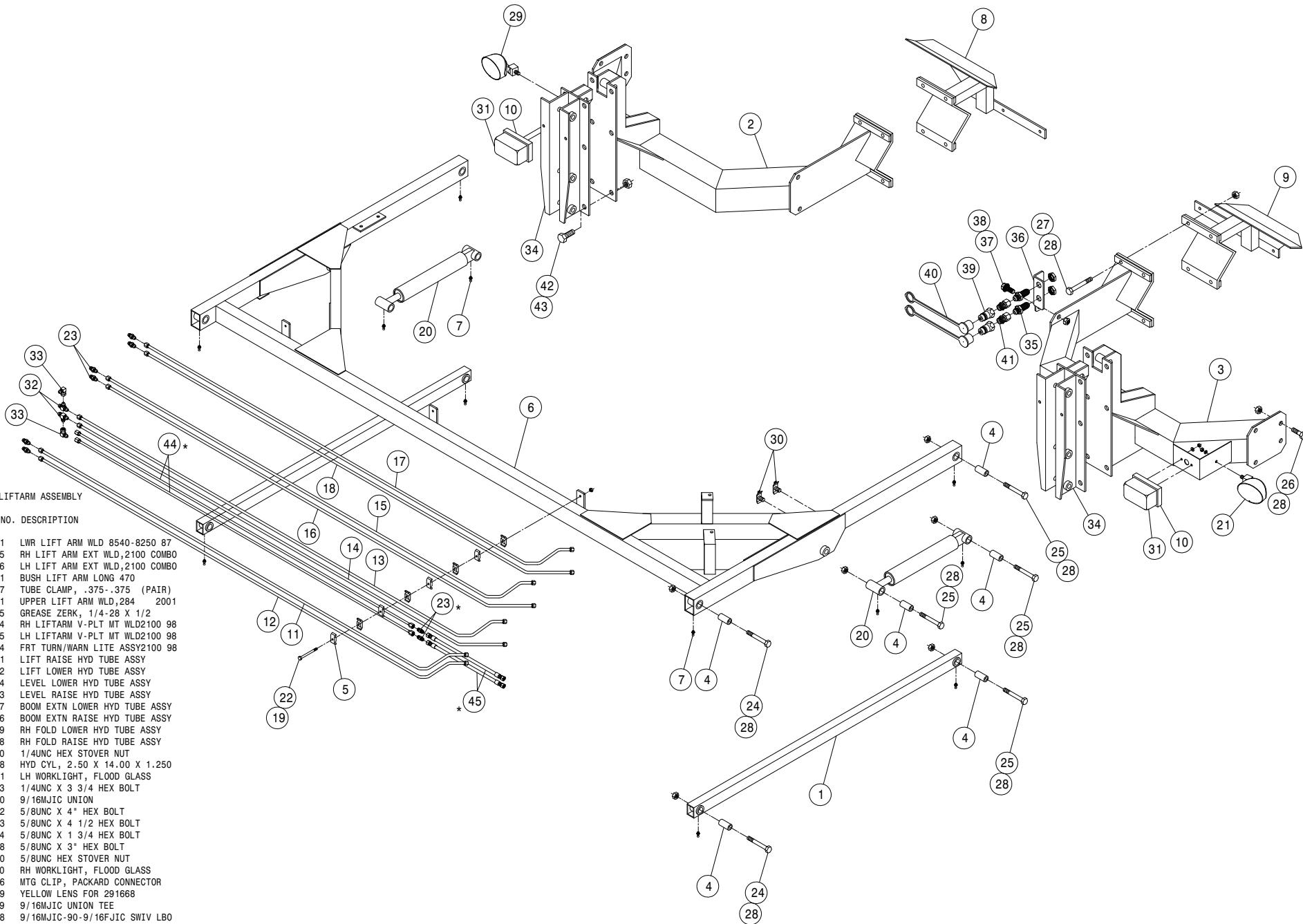

LIFTARM ASSEMBLY

DET. QTY PART NO. DESCRIPTION

1	2	160471	LWR LIFT ARM WLD 8540-8250 87
2	1	164405	RH LIFT ARM EXT WLD,2100 COMBO
3	1	164406	LH LIFT ARM EXT WLD,2100 COMBO
4	12	160691	BUSH LIFT ARM LONG 470
5	12	470287	TUBE CLAMP, .375-.375 (PAIR)
6	1	164651	UPPER LIFT ARM WLD,284 2001
7	12	471005	GREASE ZERK, 1/4-28 X 1/2
8	1	164364	RH LIFTARM V-PLT MT WLD2100 98
9	1	164365	LH LIFTARM V-PLT MT WLD2100 98
10	2	293404	FRT TURN/WARN LITE ASSY2100 98
11	1	615761	LIFT RAISE HYD TUBE ASSY
12	1	615762	LIFT LOWER HYD TUBE ASSY
13	1	615764	LEVEL LOWER HYD TUBE ASSY
14	1	615763	LEVEL RAISE HYD TUBE ASSY
15	1	615767	BOOM EXTN LOWER HYD TUBE ASSY
16	1	615766	BOOM EXTN RAISE HYD TUBE ASSY
17	1	615769	RH FOLD LOWER HYD TUBE ASSY
18	1	615768	RH FOLD RAISE HYD TUBE ASSY
19	3	914000	1/4UNC HEX STOVER NUT
20	2	621518	HYD CYL, 2.50 X 14.00 X 1.250
21	1	291901	LH WORKLIGHT, FLOOD GLASS
22	3	900013	1/4UNC X 3 3/4 HEX BOLT
23	8	619010	9/16MJIC UNION
24	4	900342	5/8UNC X 4" HEX BOLT
25	8	900343	5/8UNC X 4 1/2 HEX BOLT
26	8	900334	5/8UNC X 1 3/4 HEX BOLT
27	8	900338	5/8UNC X 3" HEX BOLT
28	28	914010	5/8UNC HEX STOVER NUT
29	1	291900	RH WORKLIGHT, FLOOD GLASS
30	2	470356	MTG CLIP, PACKARD CONNECTOR
31	2	291669	YELLOW LENS FOR 291668
32	2	618019	9/16MJIC UNION TEE
33	2	618618	9/16MJIC-90-9/16FJIC SWIV LBO
34	2	164444	OUTER CYL PLT SHIM
35	2	618349	3/4MJIC-3/4MJIC BLKHD UNION
36	1	164759	QUICK ATTACH BRKT,DTS10C '10
37	1	900264	1/2UNC X 1 1/4 HEX BOLT
38	1	914008	1/2UNC HEX STOVER NUT
39	2	618697	HYD COUPLER,MALE 1/2B, 3/4FOR
40	2	618636	RUBBER DUST CAP, 618622/697
41	2	618669	3/4FJIC SWIV-3/4MOR ADPTR
42	12	900403	3/4UNC X 2" HEX BOLT
43	12	914012	3/4UNC HEX STOVER NUT
44	2	615813	LEVEL HYD TUBE ASSY
45	2	614033	O4-482TC-06FJX-06FJX-17 H/A

NOTE: ITEMS MARKED WITH A (*) ARE MID YEAR CHANGES.

TRANSOM ASSEMBLY

DET. QTY PART NO. DESCRIPTION

1	2	160429	FEEDER HOSE SUPPORT SPRING MT
2	2	160691	
3	2	164123	1.250 SQ X 14GA X 132.00 C/L
4	2	164125	NOZL MT TUBE HANGER CHAN 96
5	2	164823	BRKAWAY PIVOT BUSH,DTS 8/10 05
6	2	164128	LEVEL CYL PIVOT BRKT WLD 96
7	2	164824	BOOM BREAKAWAY WLD,284/2101 05
8	2	900848	5/8UNC X 4 3/4 HEX BOLT GR8
9	2	470136	3/8UNC-3 1/16ID-3 SQ U-BOLT
10	4	164264	5/8UNC X 3" EYE BOLT
11	6	471005	GREASE ZERK, 1/4 28 X 1/2
12	4	473973	5/16UNC-1 5/16ID-2"SQ U-BOLTSS
13	2	900852	1"UNC 4 3/4 HBOLT,1 1/4THD GR8
14	4	910010	5/8UNC HEX NUT
15	8	914002	5/16UNC HEX STOVER NUT
16	4	914004	3/8UNC HEX STOVER NUT
17	1	164820	TRANSOM WLD, DTS 8/DTS 10 05
18	10	914010	5/8UNC HEX STOVER NUT
19	4	920005	5/8 SAE FLAT WASHER
20	4	483032	1 1/2 X 1" X .134TH MACH WASH
21	2	164830	BOOM PIVOT PIN,1.00 X 13.31 05
22	4	470117	COTTER PIN 3/16 1 3/4 SQ CUT
23	2	482000	SPRING, .930D X 8.5LG, .072WIRE
24	2	520126	CUSH CLAMP,#32 2IN X 5/8W
25	2	621522	HYD CYL, 2.00 X 10.00 X 1.000
26	2	621520	HYD CYL, 2.00 X 10.00 X 1.000
27	4	900829	5/8UNC X 4" HEX BOLT GR8
28	2	900844	5/8UNC X 2 3/4 HEX BOLT GR8
29	2	471023	GREASE ZERK 1/4-28 X 45
30	4	520099	HOSE CLAMP NO 40 STAINLESS
31	2	621211	ACCUMULATOR CYL ASSY,60 BOOM
32	2	621212	ACCUMULATOR CYL ASSY,80/90BOOM
33	4	629735	CAPPLUGS 1 1/4" SQ, BLACK POLY
34	2	470118	1/4UNC X 3/4 FLANGE HEX BOLT
35	2	470121	1/4UNC HEX FLANGE LOCK NUT
36	2	914016	1-8 HEX STOVER NUT

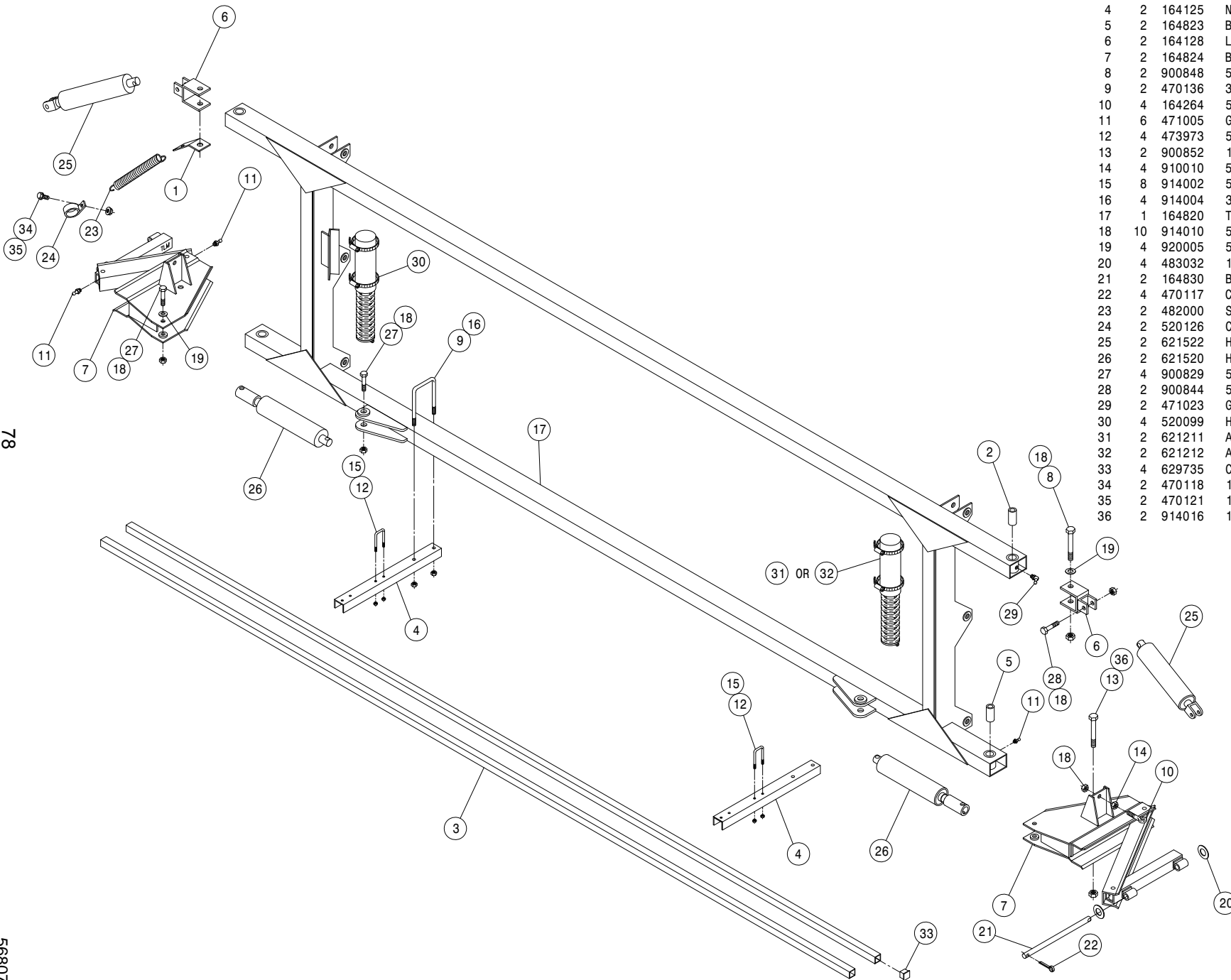

BOOM CONTROL VALVE ASSEMBLY

DET. QTY PART NO. DESCRIPTION

1	2	192514	1.00 ID CORRGTD LOOM, BLK POLY
2	16	291621	PACKARD CONNECT CAVITY PLUG
3	2	291746	PACKARD CONNECT,22WIRE TOWER
4	4	291747	PACKARD CONNECTOR COMB,22WIRE
5	2	342827	HARNESS CONNECTOR BRKT,2101 03
6	8	470121	1/4UNC HEX FLANGE LOCK NUT
7	1	605615	HYD FILTER,INLINE 25M 9/16FOR
8	1	606104	BOOM CTRL VLV, STS PWRSYS 03
9	1	618115	9/16MJIC-90-3/4MOR LBO
10	5	618119	9/16MJIC-90-9/16MOR LBO
11	5	618126	9/16MJIC-9/16MOR ADPTR
12	1	618241	3/4MJIC-90-3/4MOR LBO
13	3	618444	9/16MOR RUN TEE-9/16MJIC
14	2	618618	9/16MJIC-90-9/16FJIC SWIV LBO
15	1	618692	3/4FJIC SWIV-9/16MOR ADPTR
16	1	618486	9/16FJIC SW RUN TEE-9/16MJIC
17	2	614763	9/16MJIC-9/16MOR, .042ORF ADPTR
18	2	900146	3/8UNC X 5 3/4 HEX BOLT
19	2	914004	3/8UNC HEX STOVER NUT
20	4	470118	1/4UNC X 3/4 FLANGE HEX BOLT
21	1	605616	ELEMENT,25M HYD FILTER 605615
22	1	605617	SPRING KIT, HYD FILTER 605615
23	1	610462	GASKET FOR 610447 ARROW FILT
24	1	606109	COIL, #10 12VDC, LEADS & DIODE
25	1	606147	MAIN #10 SOLENOID FOR 606102
26	1	606169	SEAL KIT FOR 606147 SOLENOID
27	13	606143	COIL, #08, 12VDC, LEADS & DIODE
28	1	606146	MAIN #8 SOLENOID FOR 606102
29	1	606167	SEAL KIT FOR 606146 SOLENOID
30	6	606145	SOLENOID, 4W3P #08, (606103/104)
31	6	606168	SEAL KIT FOR 606145 SOLENOID
32	6	606148	#10 CHECK VALVE FOR 606103

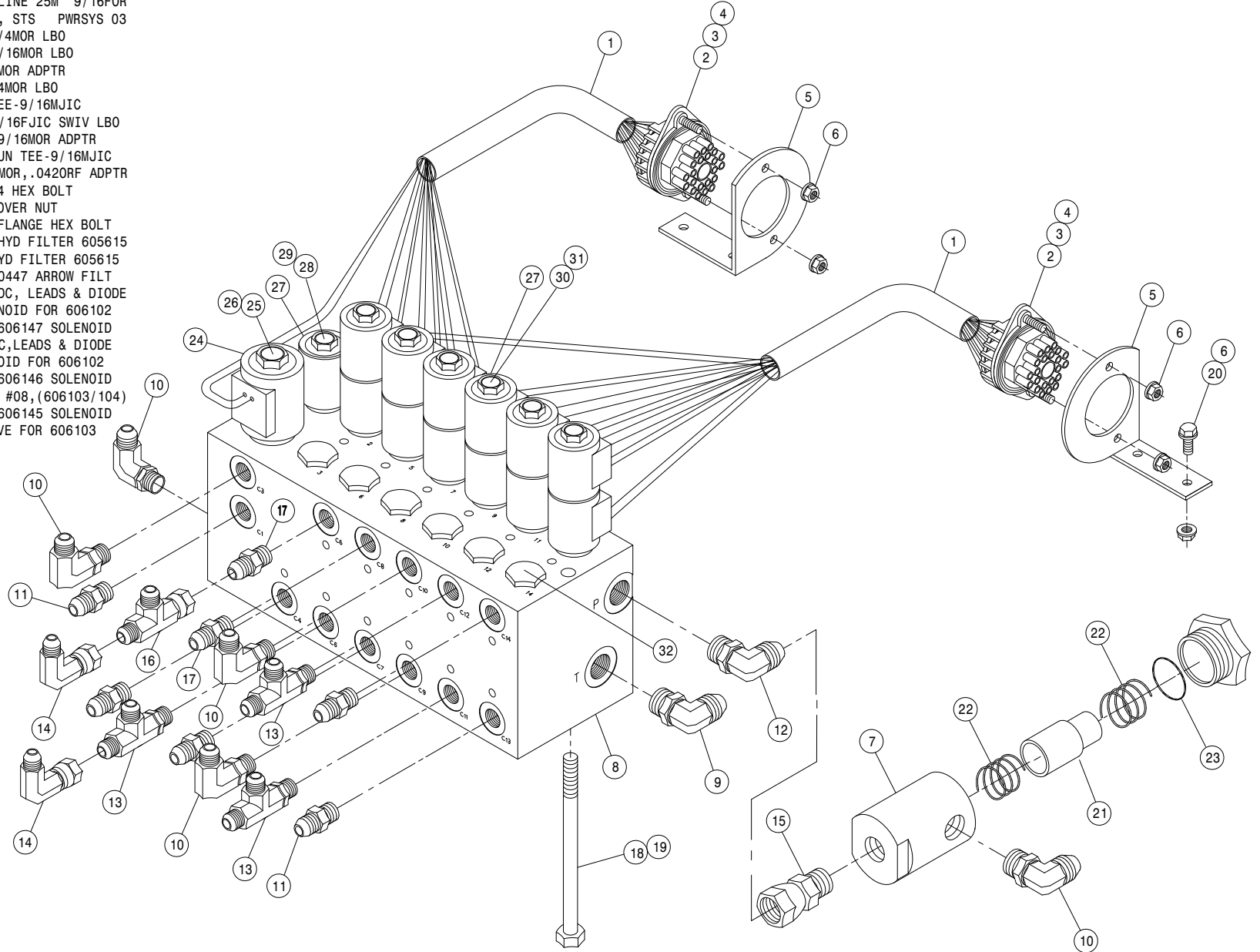

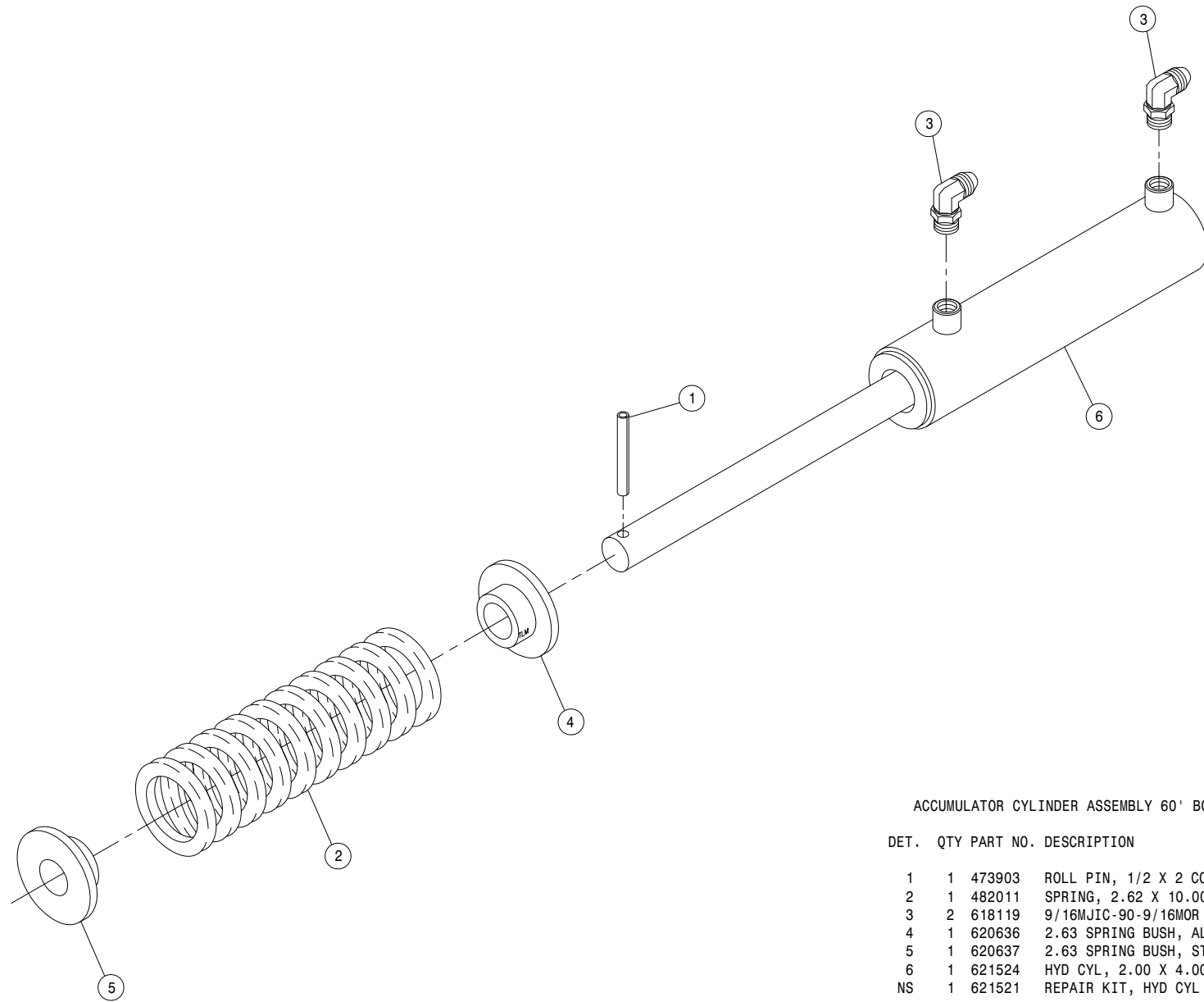

ACCUMULATOR CYLINDER ASSEMBLY 60' BOOM

DET. QTY PART NO. DESCRIPTION

1	1	473903	ROLL PIN, 1/2 X 2 COILED
2	1	482011	SPRING, 2.62 X 10.00 COMPRSN
3	2	618119	9/16MJIC-90-9/16MOR LBO
4	1	620636	2.63 SPRING BUSH, ALUM 96
5	1	620637	2.63 SPRING BUSH, STEEL 96
6	1	621524	HYD CYL, 2.00 X 4.00 X 1.000
NS	1	621521	REPAIR KIT, HYD CYL 621520

NOTE: 621211 - ACCUMULATOR CYLINDER ASSEMBLY

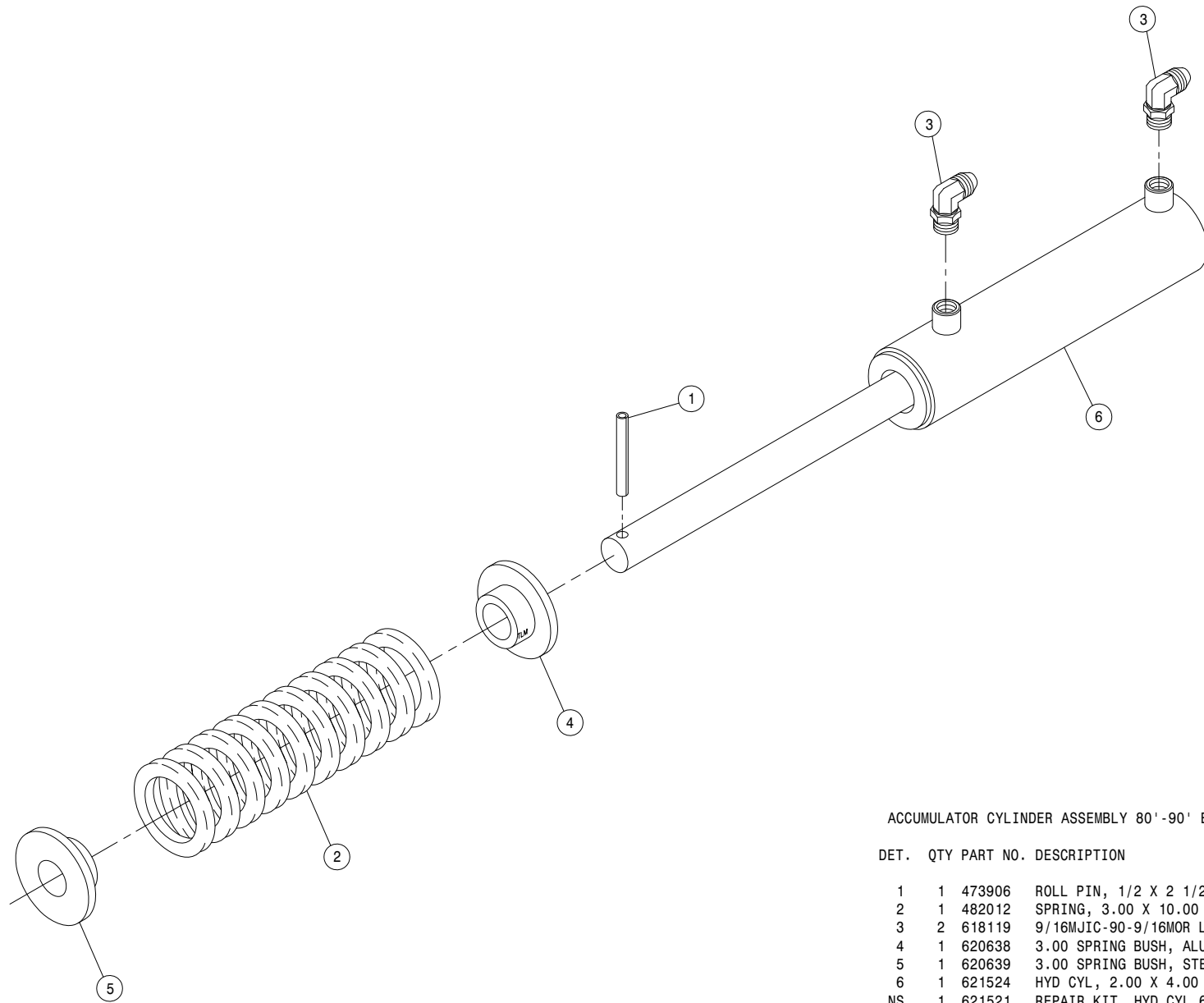

ACCUMULATOR CYLINDER ASSEMBLY 80' -90' BOOM

DET. QTY PART NO. DESCRIPTION

1	1	473906	ROLL PIN, 1/2 X 2 1/2 COILED
2	1	482012	SPRING, 3.00 X 10.00 COMPRSN
3	2	618119	9/16MJIC-90-9/16MOR LBO
4	1	620638	3.00 SPRING BUSH, ALUM 96
5	1	620639	3.00 SPRING BUSH, STEEL 96
6	1	621524	HYD CYL, 2.00 X 4.00 X 1.000
NS	1	621521	REPAIR KIT, HYD CYL 621520

NOTE: 621212 - ACCUMULATOR CYLINDER ASSEMBLY

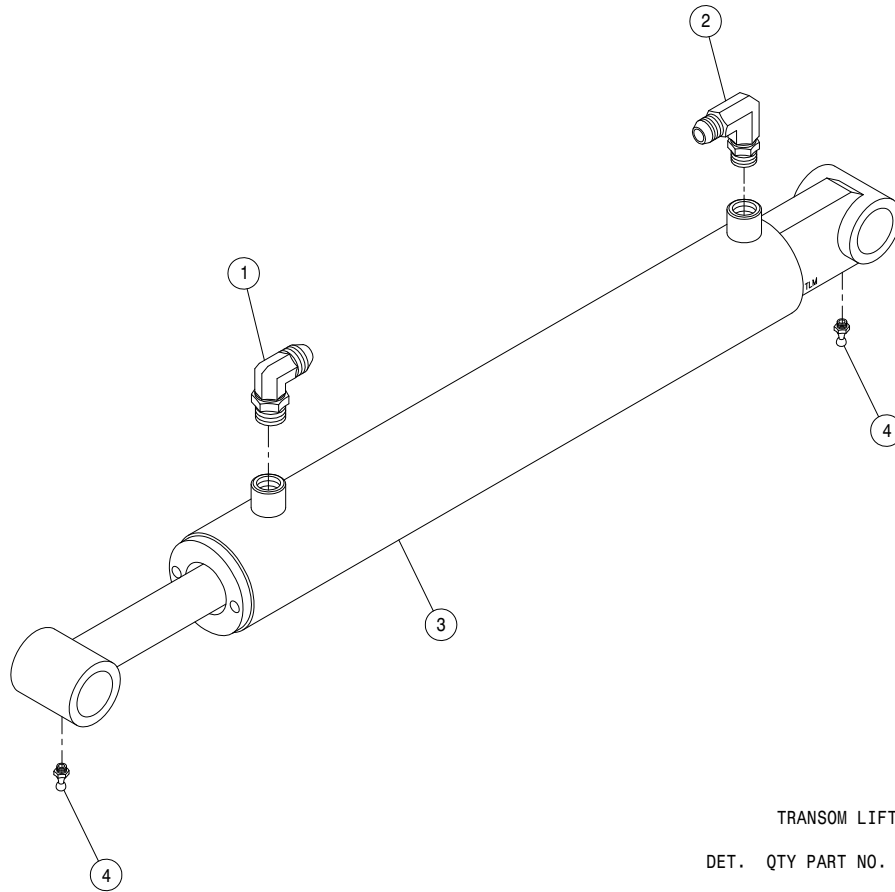

TRANSOM LIFT CYLINDER ASSEMBLY

DET.	QTY	PART NO.	DESCRIPTION
1	1	618119	9/16MJIC-90-9/16MOR LBO
2	1	618689	9/16MJ-90-9/16MOR .042 CHK VLV
3	1	621518	HYD CYL, 2.50 X 14.00 X 1.250
4	2	471005	GREASE ZERK, 1/4 28 X 1/2
NS	1	621519	REPAIR KIT, HYD CYL 621518

NOTE: 621207 - TRANSOM LIFT CYLINDER ASSEMBLY WITH FITTINGS

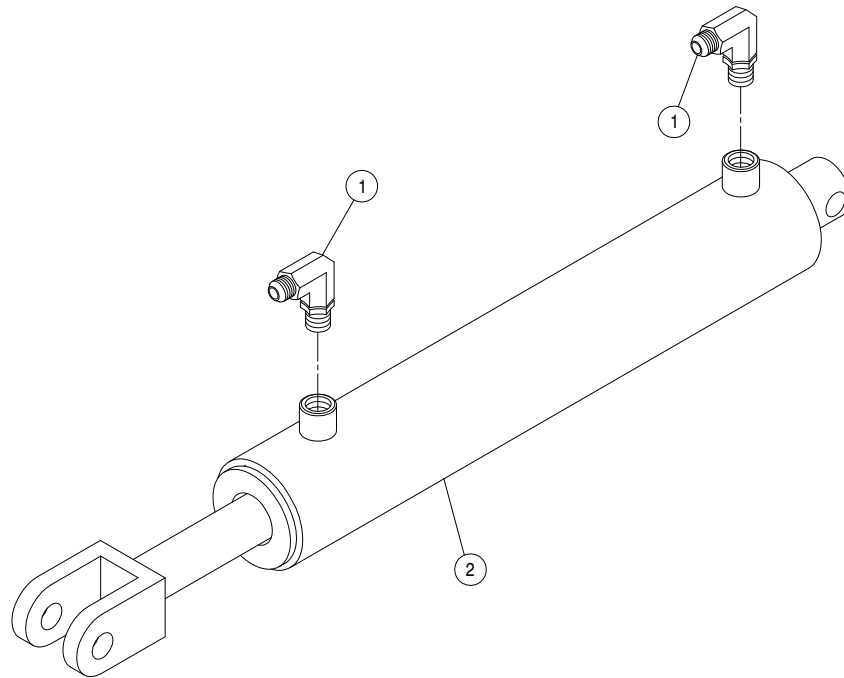

BOOM LEVEL CYLINDER ASSEMBLY

DET. QTY PART NO. DESCRIPTION

1	2	618119	9/16MJIC-90-9/16MOR LBO
2	1	621522	HYD CYL, 2.00 X 10.00 X 1.000
NS	1	621521	REPAIR KIT, HYD CYL 621520

NOTE: 621210 - BOOM LEVEL CYLINDER ASSEMBLY WITH FITTINGS

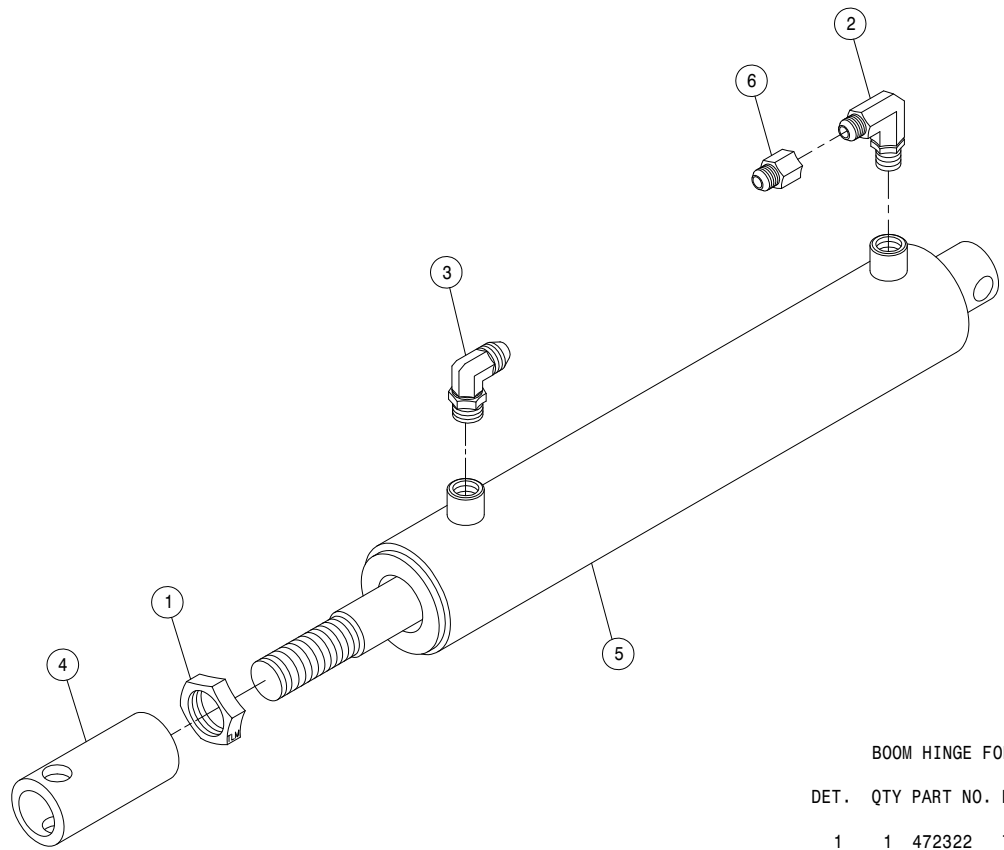

BOOM HINGE FOLD CYLINDER ASSEMBLY

DET.	QTY	PART NO.	DESCRIPTION
1	1	472322	7/8-14 UNF HEX JAM NUT
2	1	618119	9/16MJIC-90-9/16MOR LBO
3	1	618688	9/16MJ-90-9/16MOR .025 CHK VLV
4	1	620653	FOLD CYL ADJ SLEEVE 97
5	1	621520	HYD CYL, 2.00 X 10.00 X 1.000
6	1	618733	9/16JIC .042 ORIFICE ADPTR
NS	1	621521	REPAIR KIT, HYD CYL 621520

NOTE: 621208 - BOOM HINGE FOLD CYLINDER ASSEMBLY WITH FITTINGS

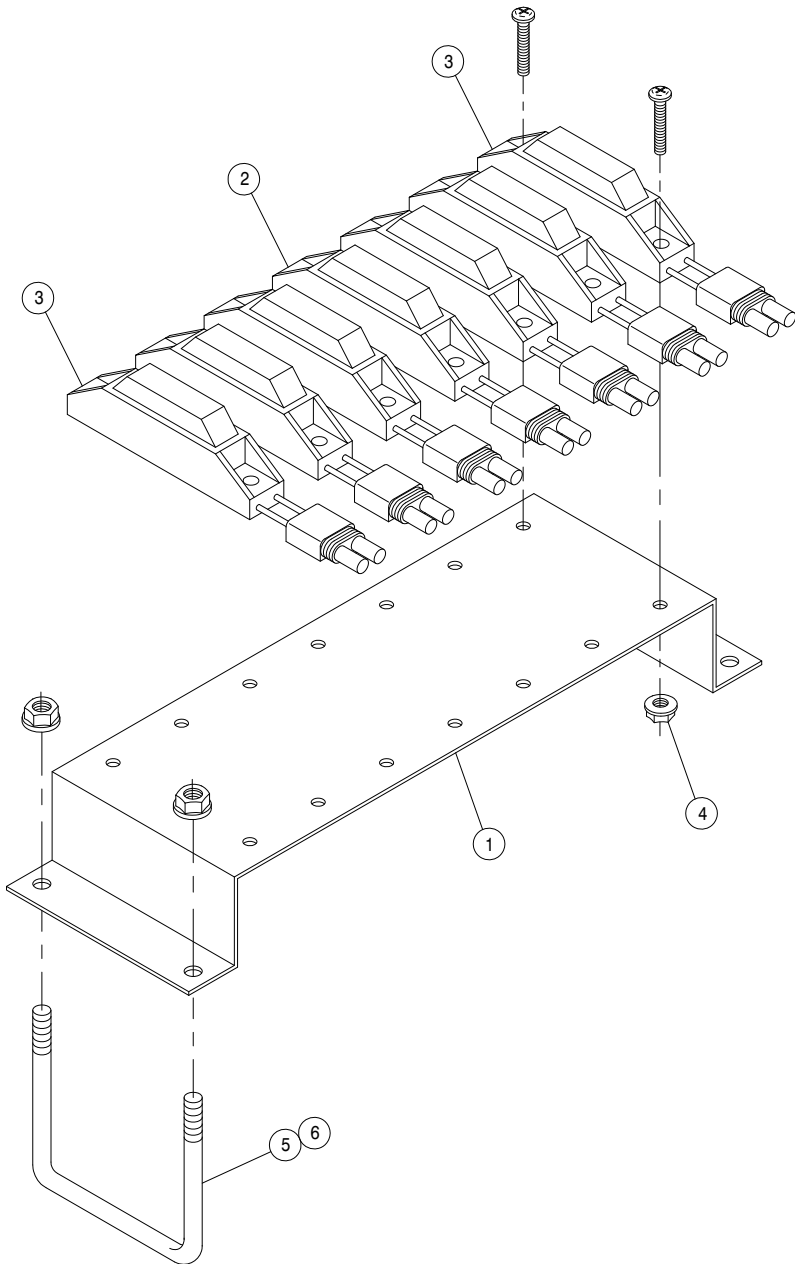

BOOM SECTION LIGHT ASSEMBLY

DET. QTY PART NO. DESCRIPTION

1	1	164386	BOOM SECT ID LIGHT BRKT2100 98
2	5	291661	LAMP KIT, RED 12V
3	2	291662	LAMP KIT, YELLOW 12V
4	14	470175	10-32 HEX FLANGE LOCK NUT
5	2	473970	1/4UNC-1 1/16ID-2 3/4 U-BOLTSQ
6	4	470121	1/4UNC HEX FLANGE LOCK NUT

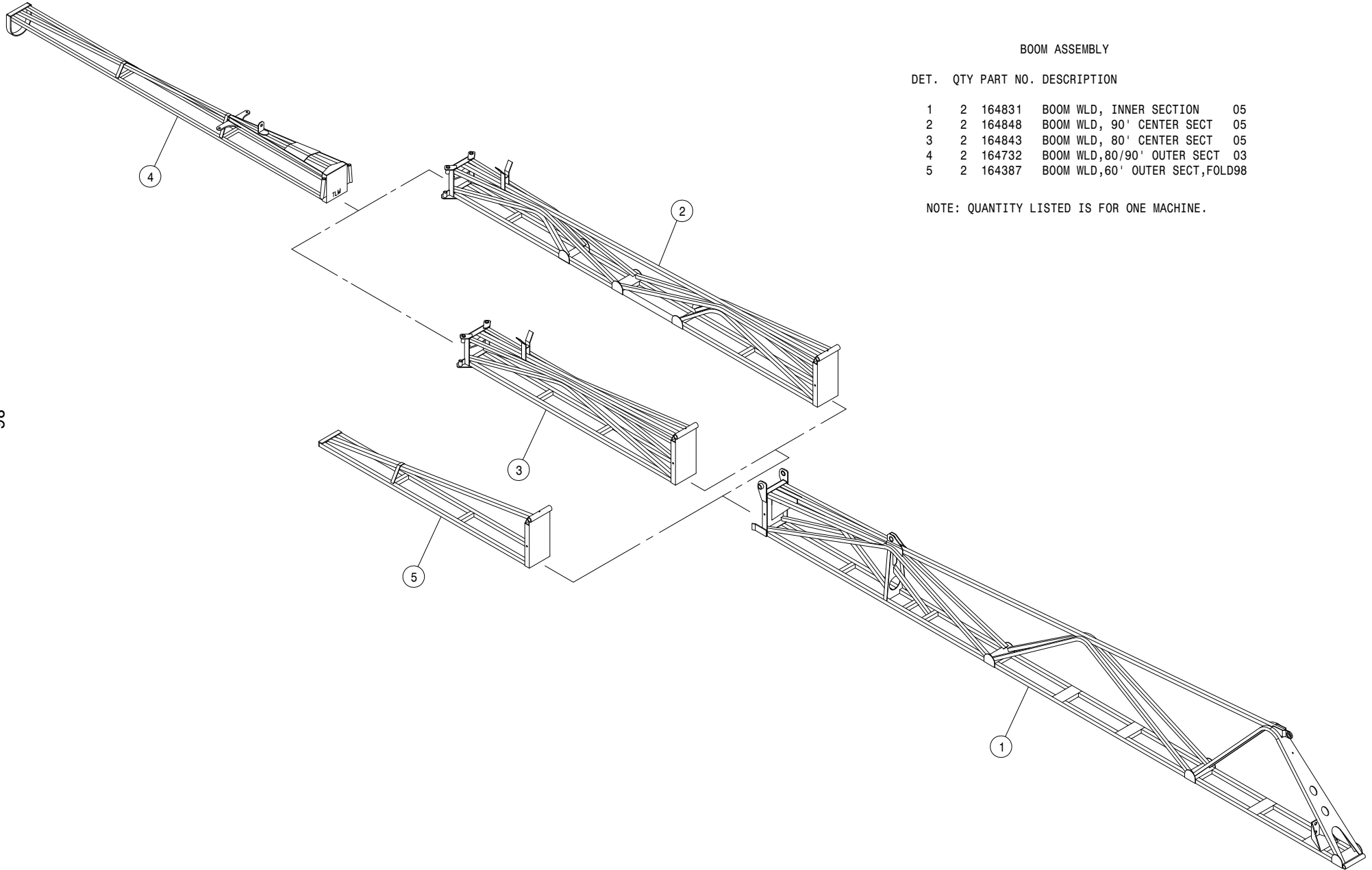

BOOM ASSEMBLY

DET. QTY PART NO. DESCRIPTION

1	2	164831	BOOM WLD, INNER SECTION	05
2	2	164848	BOOM WLD, 90' CENTER SECT	05
3	2	164843	BOOM WLD, 80' CENTER SECT	05
4	2	164732	BOOM WLD, 80/90' OUTER SECT	03
5	2	164387	BOOM WLD, 60' OUTER SECT, FOLD98	

NOTE: QUANTITY LISTED IS FOR ONE MACHINE.

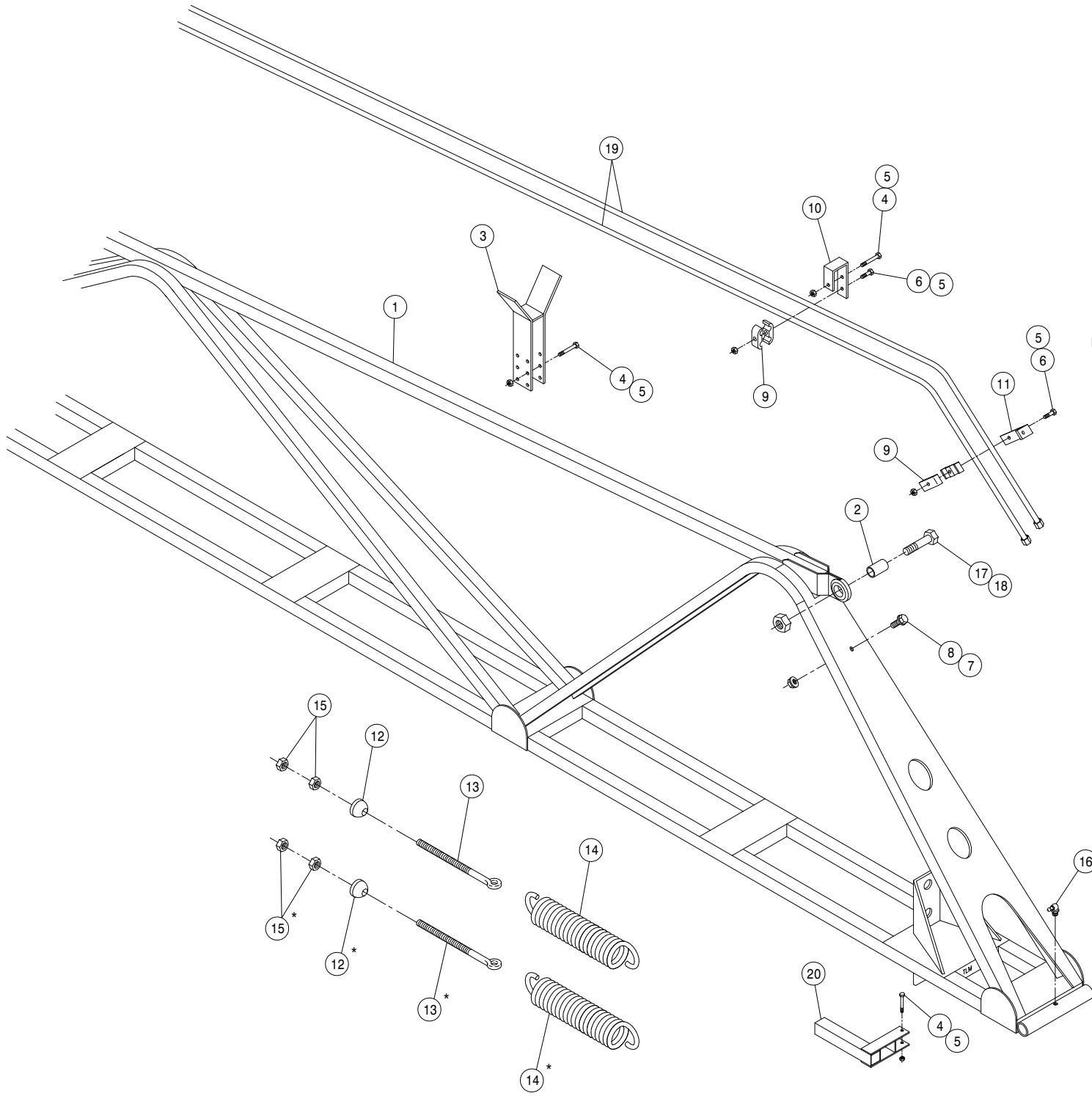

INNER BOOM ASSEMBLY

DET.	QTY	PART NO.	DESCRIPTION	
1	2	164831	BOOM WLD, INNER SECTION	05
2	2	164227	.750 OD X 17GA X 1.25	C/L
3	2	164266	OUTER BOOM SUPP WLD,80/90' 96	
4	18	900007	1/4UNC X 2" HEX BOLT	
5	28	914000	1/4UNC HEX STOVER NUT	
6	10	900004	1/4UNC X 1 1/4 HEX BOLT	
7	2	470121	1/4UNC HEX FLANGE LOCK NUT	
8	2	470118	1/4UNC X 3/4 FLANGE HEX BOLT	
9	10	470287	TUBE CLAMP, .375-.375 (PAIR)	
10	8	164242	HYD TUBE HANGER CLEVIS,BOOM96	
11	2	164243	HYD TUBE HANGER ANGLE,BOOM 96	
12	4	164263	SWIVEL, 5/8 BOOM EYEBOLT	
13	4	164265	5/8UNC X 7 1/2 EYE BOLT	
14	4	482014	SPRING,3.25 X 11.50 EXTENSION	
15	8	910010	5/8UNC HEX NUT	
16	2	471028	GREASE ZERK, 1/4-28 90DEG	
17	2	900844	5/8UNC X 2 3/4 HEX BOLT GR8	
18	2	914010	5/8UNC HEX STOVER NUT	
19	4	615684	HYD TUBE ASSY,BOOM EXT FOLD96	
20	2	164275	NOZL MT WLD	96

NOTE: 1. QUANTITY LISTED IS FOR ONE MACHINE.
 2. (*) 60 FOOT BOOM USES ONE SPRING SETUP.

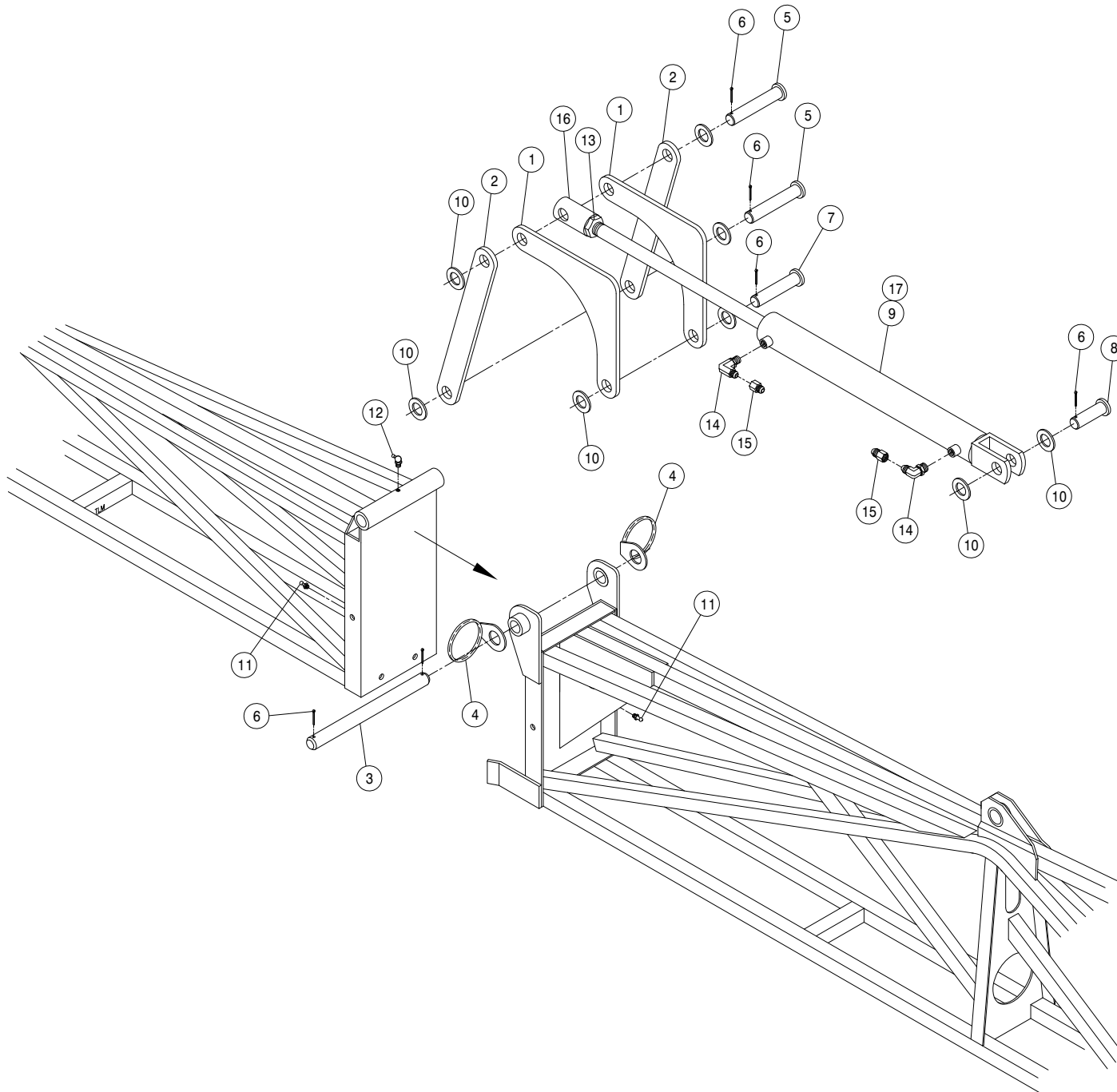

80'-90' BOOM HINGE PIVOT ASSEMBLY

DET. QTY PART NO. DESCRIPTION

1	4	164228	FOLDING LINK, INNER BOOM	96
2	4	164229	FOLDING LINK, BOOM CNTR SECT96	
3	2	164231	BOOM PIN, 1.00 X 11.75	96
4	4	438302	HOSE SUPPORT RING WLD	
5	4	470155	CLEVIS PIN, 1.00 X 4.00	PLT
6	12	470162	COTTER PIN 3/16 X 1 1/2	SQCUT
7	2	472012	CLEVIS PIN, 1.00 X 3.25	PLT
8	2	472270	CLEVIS PIN, 1.00 X 2.50	PLT
9	2	621526	HYD CYL, 2.50 X 16.94 X 1.250	
10	16	920008	1" SAE FLAT WASHER	
11	4	471005	GREASE ZERK, 1/4 28 X 1/2	
12	2	471028	GREASE ZERK, 1/4-28 90DEG	
13	2	472328	1-12 HEX JAM NUT	
14	4	618119	9/16MJIC-90-9/16MOR LBO	
15	4	618733	9/16JIC .042 ORIFICE ADPTR	
16	2	620681	CENTER FOLD CYL ADJ SLEEVE	12T
17	2	621527	REPAIR KIT, HYD CYL 621526	

NOTE: QUANTITY LISTED IS FOR ONE MACHINE.

80'-90' OUTER BOOM HINGE ASSEMBLY

DET. QTY PART NO. DESCRIPTION

1	2	160351	BOOM PIVOT PIN, .625 X 11.50
2	2	160979	1/2UNC X 9" EYE BOLT
3	2	160981	SWIVEL, 1/2" BOOM EYEBOLT
4	2	164732	BOOM WLD,80/90' OUTER SECT 03
5	2	164734	CYL MT ARM WLD,80/90 CNTR SECT
6	2	164737	BOOM SPRING PIN WLD 03
7	2	164666	OUTER BOOM SUPPORT WLD 00
8	6	470162	COTTER PIN 3/16 X 1 1/2 SQ CUT
9	2	482013	SPRING,2.50 X 17.00 EXTENSION
10	8	900007	1/4UNC X 2" HEX BOLT
11	4	910008	1/2UNC HEX NUT
12	8	914000	1/4UNC HEX STOVER NUT
13	4	920005	5/8 SAE FLAT WASHER
14	2	471005	GREASE ZERK, 1/4 28 X 1/2
15	2	473895	1/4 X 1 3/4 LINCHPIN
16	2	621554	HYD CYL, 1.50 X 12.25 X .750
17	2	616042	04-482TC-06FJX-06FJX-13 H/A
18	2	618119	9/16MJIC-90-9/16MOR LBO
19	2	618689	9/16MJ-90-9/16MOR .042 CHK VLV
20	6	900266	1/2UNC X 1 3/4 HEX BOLT
21	8	914008	1/2UNC HEX STOVER NUT
22	2	900267	1/2UNC X 2" HEX BOLT
23	2	621555	REPAIR KIT, HYD CYL 621554
24	2	470098	RUBBER BUMPER 2.500D X .38ID
25	2	483043	3/8 REGULAR FLAT WASHER
26	1	900131	3/8UNC X 1 1/2 HEX BOLT
27	1	914004	3/8UNC HEX STOVER NUT

NOTE: 1. QUANTITY LISTED IS FOR ONE MACHINE.

2. PARTS MARKED WITH (*) ARE USED ON THE LH SIDE OF THE 90' BOOM OPTION.

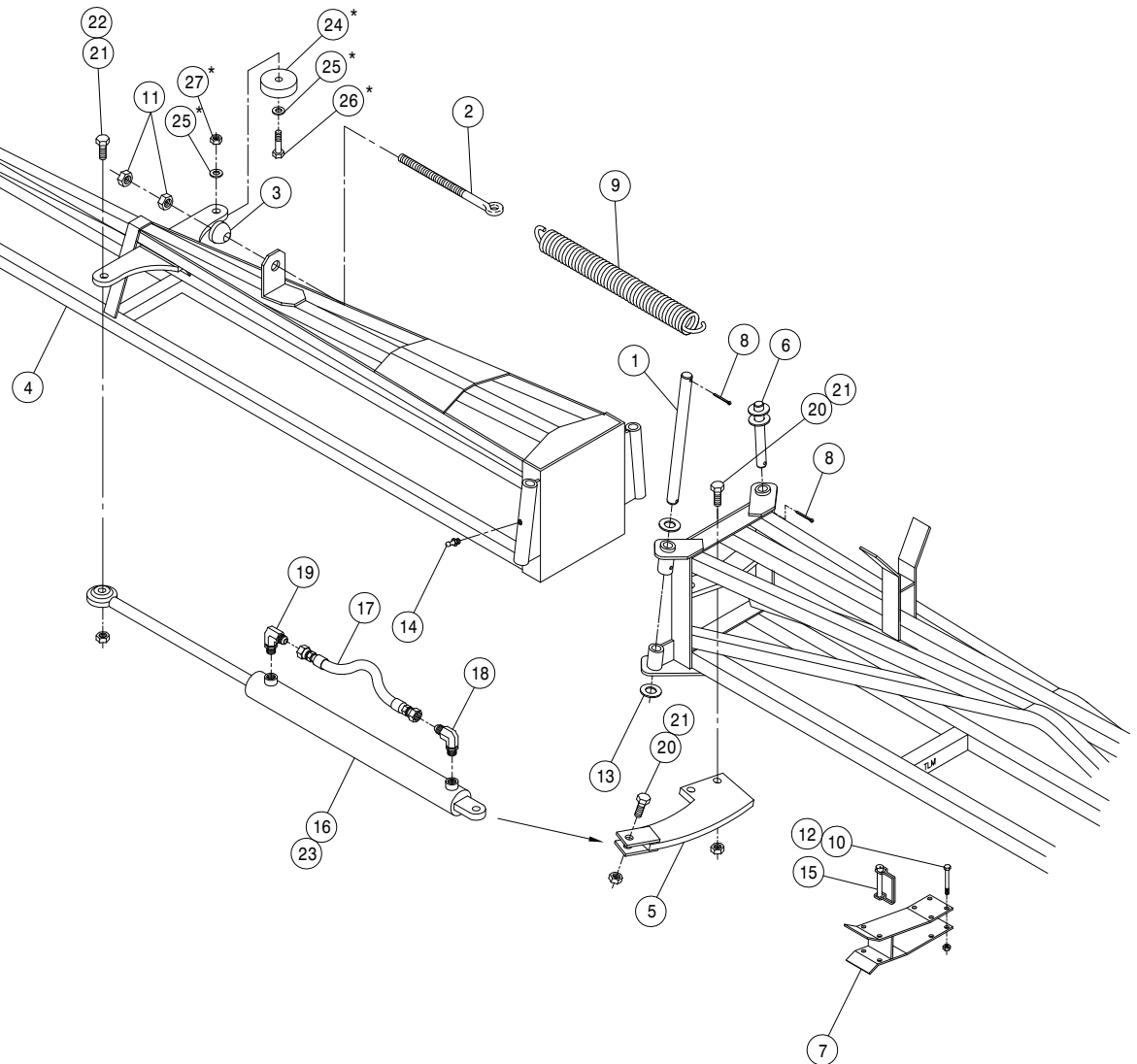

60' BOOM HINGE PIVOT ASSEMBLY

DET. QTY PART NO. DESCRIPTION

1	2	164387	BOOM WLD,60' OUTER SECT,FOLD98
2	2	164231	BOOM PIN, 1.00 X 11.75 96
3	12	470162	COTTER PIN 3/16 X 1 1/2 SQCUT
4	2	164388	OUTER BOOM SUPP WLD,60'FOLD 98
5	4	900007	1/4UNC X 2" HEX BOLT
6	4	914000	1/4UNC HEX STOVER NUT
7	4	438302	HOSE SUPPORT RING WLD
8	4	471005	GREASE ZERK, 1/4 28 X 1/2
9	2	471028	GREASE ZERK, 1/4-28 90DEG
10	4	164228	FOLDING LINK, INNER BOOM 96
11	4	164229	FOLDING LINK,BOOM CNTR SECT96
12	4	470155	CLEVIS PIN, 1.00 X 4.00 PLT
13	2	472012	CLEVIS PIN, 1.00 X 3.25 PLT
14	2	472270	CLEVIS PIN, 1.00 X 2.50 PLT
15	2	621526	HYD CYL, 2.50 X 16.94 X 1.250
16	16	920008	1" SAE FLAT WASHER
17	2	472328	1-12 HEX JAM NUT
18	4	618119	9/16MJIC-90-9/16MOR LBO
19	4	618733	9/16JIC .042 ORIFICE ADPTR
20	2	620681	CENTER FOLD CYL ADJ SLEEVE 12T
21	2	621527	REPAIR KIT, HYD CYL 621526

NOTE: QUANTITY LISTED IS FOR ONE MACHINE.

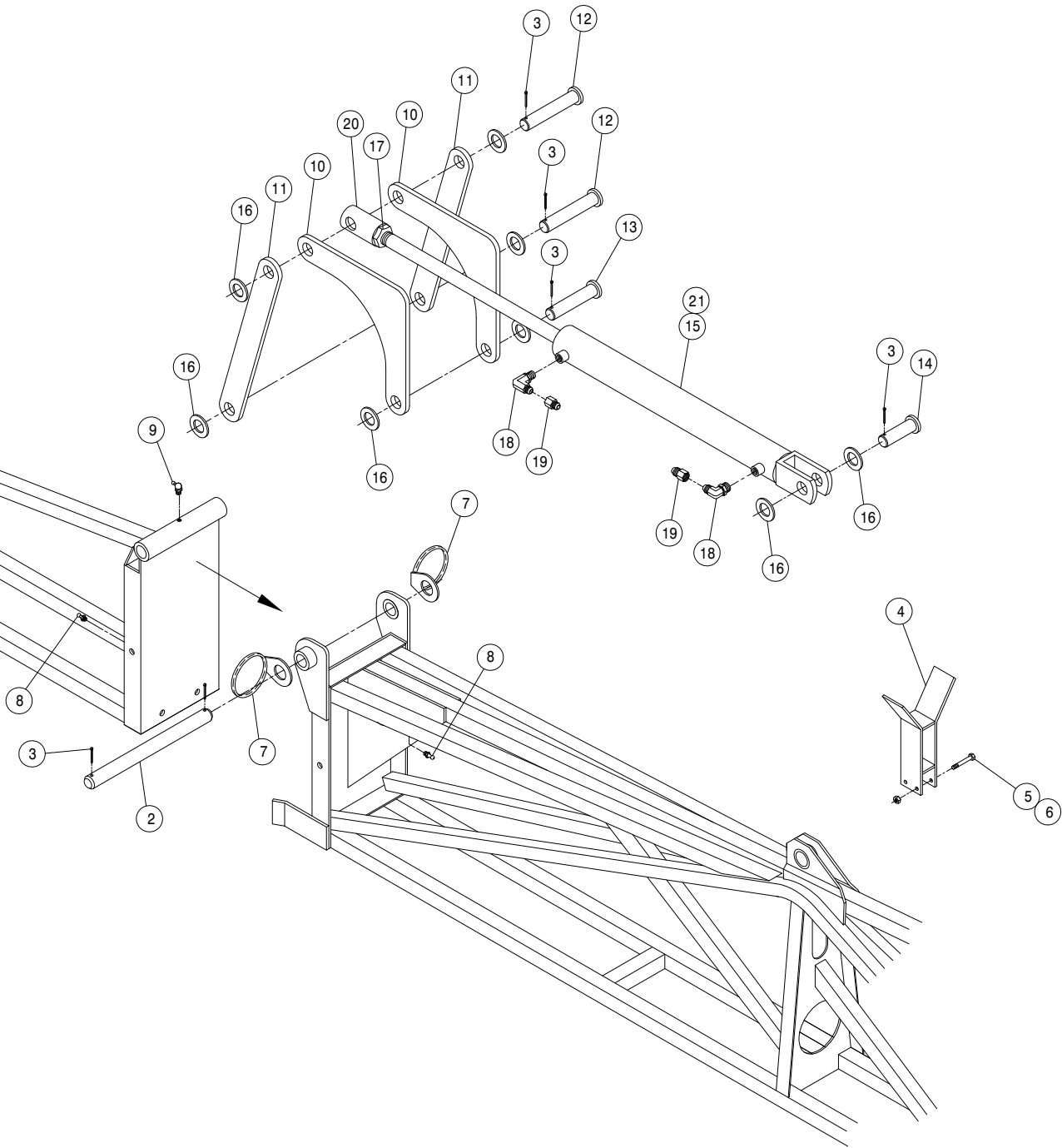

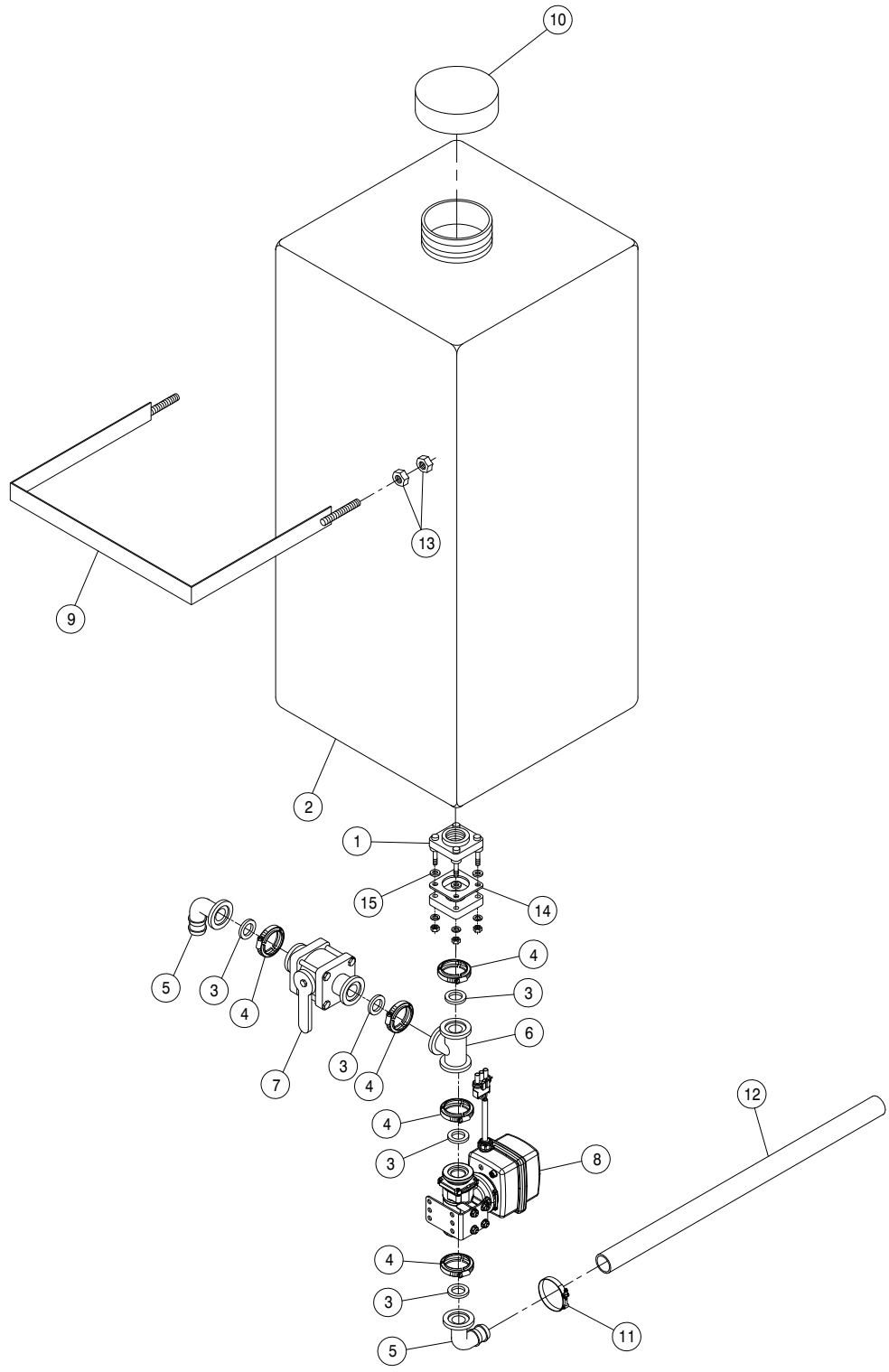

RINSE TANK ASSEMBLY

DET.	QTY	PART NO.	DESCRIPTION
	1	500178	1"FLG TANK FTG,BOTDRN BLT POLY
	1	763475	55 GAL TANK, RECTANGLE VERTICL
	5	500157	1" FLANGE GASKET EPDM
	5	500159	1" FLANGE CLAMP, S.S.
	2	500173	1" FLANGE-90-1" HOSE BARB POLY
	1	500175	1" FLANGE TEE POLY
	1	696147	BALL VLV, 1" FLANGE
	1	696282	VALVE,KZCO C2E 1"FLG ELEC W/WP
	1	342621	RINSE TANK BAND WLD, 2100 98
	1	763474	LID, 55 GAL RINSE TANK 763475
	1	520138	1.38/1.56 T-BOLT HOSE CLAMP
	1	601425	HOSE, 1 X 192 2F-1W EPDM
	4	910008	1/2UNC HEX NUT
	1	500221	FULL GASKET,1" TANK FTG 500178
	4	500222	FOOT GASKET,1" TANK FTG 500178

FOAM MARKER TANK ASSEMBLY

NOTE: 1. DETAIL 28 AND 29 ARE USED WITH THE 60 FT BOOM.
 2. DETAIL 30 AND 31 ARE USED WITH THE 80 FT BOOM.
 3. DETAIL 32 AND 33 ARE USED WITH THE 90 FT BOOM.

DET. QTY PART NO. DESCRIPTION

1	2	500043	3/4NPT PIPE PLUG, POLY
2	2	701214	1/2NPT-90-3/4HBARB,1/4TAP,POLY
3	1	507728	REDU BUSH 1/2MNPT X 1/4FNPT,SS
4	1	505205	BLK PIPE NIPPLE 1.00NPT-5.00
5	1	505211	3/8-1/4NPT REDU BUSH, BRS
6	3	520120	HOSE CLAMP NO 4 STAINLESS
7	1	601419	HOSE, 3/8 X 30 CLEAR VINYL
8	1	601420	HOSE, 3/8 X 48 CLEAR VINYL
9	1	618571	1/4MNPT-90-1/4MNPT LBO
10	1	695900	BALL VALVE 1IN FNPT POLY
11	2	696120	BALL VALVE, 1/4NPT, STEEL
12	1	696134	BALL VALVE 2IN FNPT POLY
13	2	696181	3/4" ELECT SOLU SOLE VALVE 02
14	1	701143	FOAMER AIR TUBE FTG
15	1	701112	FOAMER MARKER TANK, 36 GAL SS
16	1	711049	1/4 NYL TUBE-1/4MNPT FTG
17	1	711052	1/4"NPT CHECK VALVE,SWING,2600
18	1	783304	1/4 NPT X 3/8 HOSE BARB, BRS
19	4	193002	SPIRAL PROTECTIVE WRAP, BLACK
20	2	342333	NYL HOSE SLEEVE,2.64ID X 12.00
21	4	342623	FOAMER TANK BAND WLD, 2100 98
22	2	696209	CAP FOR .75 MALE COUPLER POLY
23	6	520055	HOSE CLAMP NO 12 STAINLESS
24	2	900138	3/8UNC X 3 1/2 HEX BOLT
25	6	914004	3/8UNC HEX STOVER NUT
26	2	920002	3/8 SAE FLAT WASHER
27	2	195908	HOSE 3/4ID-1/8W CLEAR VINYL
28	1	195908	HOSE 3/4ID-1/8W CLEAR VINYL
29	1	195908	HOSE 3/4ID-1/8W CLEAR VINYL
30	1	195908	HOSE 3/4ID-1/8W CLEAR VINYL
31	1	195908	HOSE 3/4ID-1/8W CLEAR VINYL
32	1	195908	HOSE 3/4ID-1/8W CLEAR VINYL
33	1	195908	HOSE 3/4ID-1/8W CLEAR VINYL
34	1	601790	HOSE, 1/4 X 79 AIR
35	1	507021	SS PIPE NIPPLE, 1/8NPT X 6"
36	1	500223	SS PIPE CPLG, 1/8NPT
37	1	701144	FOAMER AIR NOZZLE
38	1	342658	FOAMER TANK SUPP WLD, 2100 98
39	1	910008	1/2UNC HEX NUT
40	2	920504	1/2 LOCK WASHER
41	1	914008	1/2UNC HEX STOVER NUT
42	2	701215	1/4PIPE PLUG, .187 ORIFICE,POLY
43	1	501450	BLK PIPE ST EL 90DEG .25NPT
44	2	500079	3/4NPT-90 EL, POLY
45	2	696207	.75 HOSE BARB-FEMALE COUPLER
46	2	696208	.75 HOSE BARB-MALE COUPLER
47	2	696204	PLUG FOR .50/.75 FEM COUPLER

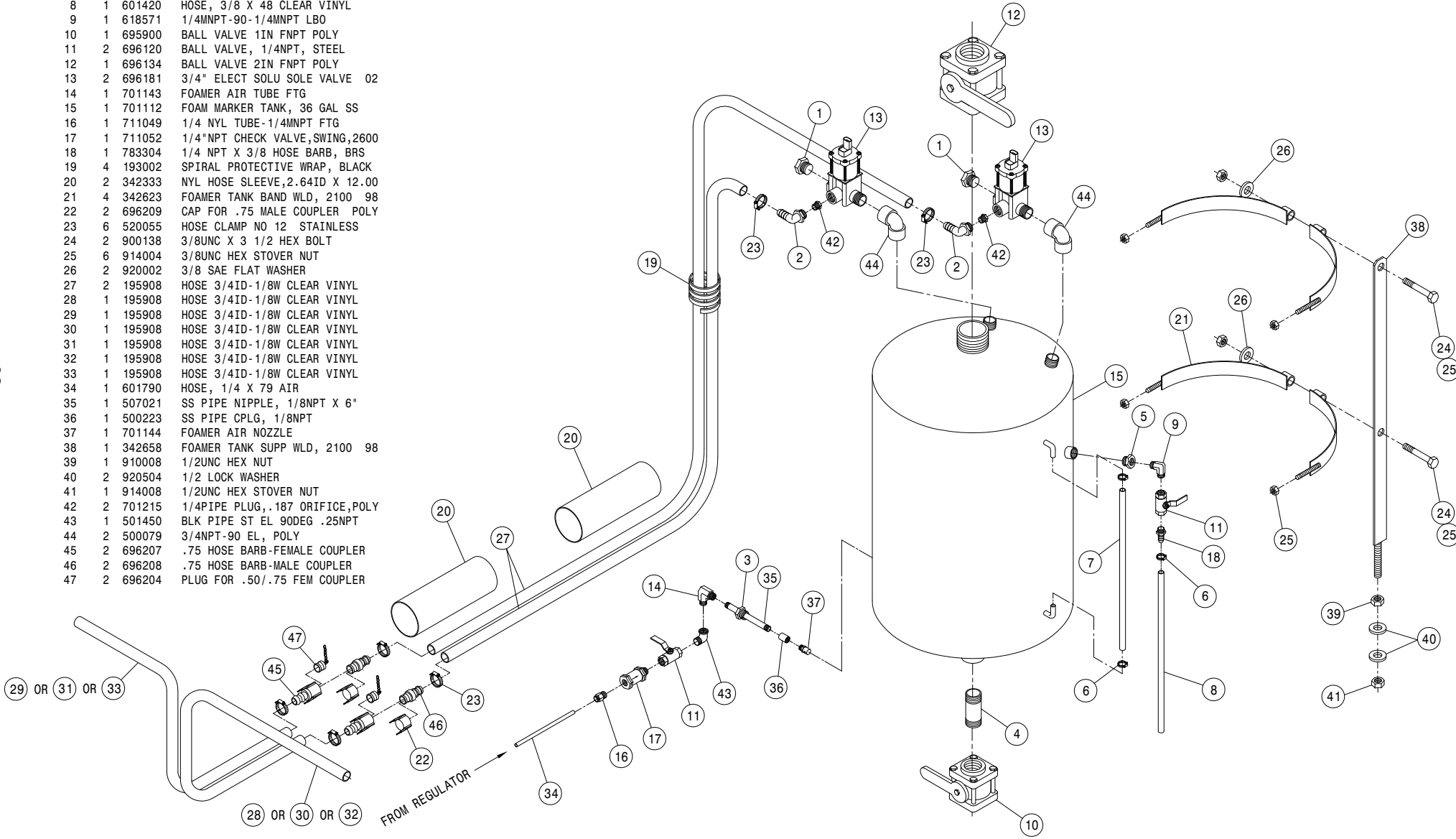

92

568092

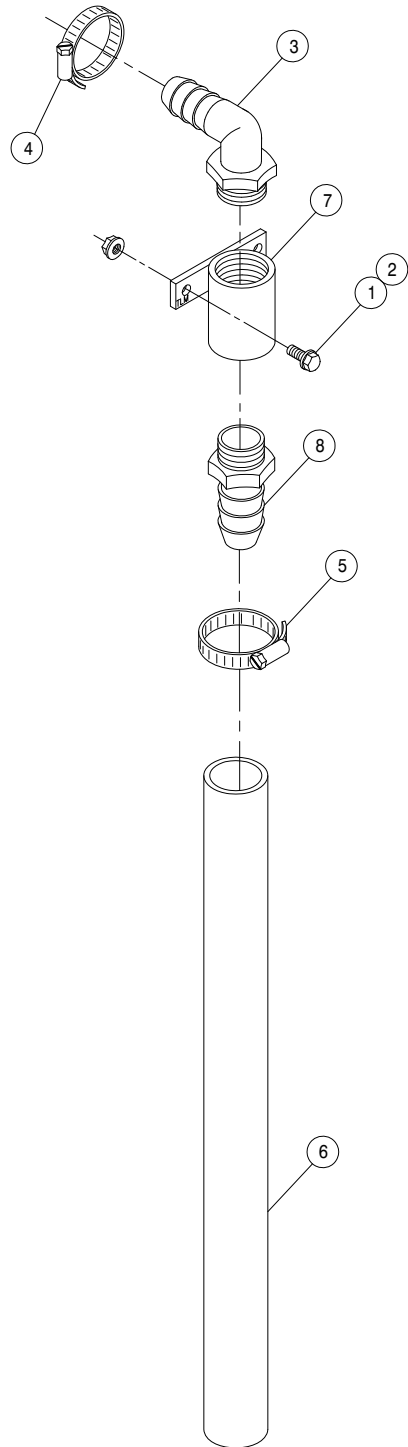

FOAMER DROP END ASSEMBLY

DET. QTY PART NO. DESCRIPTION

1	4	470118	1/4UNC X 3/4 FLANGE HEX BOLT
2	4	470121	1/4UNC HEX FLANGE LOCK NUT
3	2	500067	1 NPT-90-3/4 HOSE BARB, POLY
4	2	520055	HOSE CLAMP NO 12 STAINLESS
5	2	520085	HOSE CLAMP NO 24 STAINLESS
6	2	601367	HOSE, 1 1/4 X 24 2BR BLK EPDM
7	2	701102	FOAM MARKER DROP CPLR WELD
8	2	714561	1.00NPT-1.25 HOSE BARB

NOTE: QUANTITY LISTED IS FOR ONE MACHINE.

TREAD ADJUST HYDRAULIC VALVE ASSEMBLY

DET. QTY PART NO. DESCRIPTION

1	4	291621	PED,SEAL,CAVITY PLUG,GREEN
2	1	291746	PED,PLUG,WP,22W
3	2	291747	PACKARD CONNECTOR COMB,22WIRE
4	1	342827	HARNESS CONNECTOR BRKT,2101 03
5	1	361487	TREAD ADJ VLV BRKT, 2100 2000
6	2	470118	1/4UNC X 3/4 FLANGE HEX BOLT
7	4	470121	1/4UNC HEX FLANGE LOCK NUT
8	1	605615	HYD FILTER,INLINE 25M 9/16FOR
9	1	606107	TREAD ADJ VLV,2101 PWRSYS 03
10	1	611125	3/4MJIC-3/4MOR ADPTR
11	1	618109	9/16MJIC-3/4MOR ADPTR
12	9	618115	9/16MJIC-90-3/4MOR LBO
13	1	618609	3/4MJIC-90-3/4FJIC SWIV LBO
14	4	900129	3/8UNC X 1" SERR FLANGE BOLT
15	1	618692	3/4FJIC SWIV-9/16MOR ADPTR
16	2	900145	3/8UNC X 5 SOCKET HD CAP SCR
17	6	914004	3/8UNC HEX STOVER NUT
18	8	920002	3/8 SAE FLAT WASHER
19	4	606148	#10 CHECK VALVE FOR 606103
20	4	606145	SOLENOID,4W3P #08, (606103/104)
21	8	606143	COIL,#08,12VDC,LEADS & DIODE
22	1	610462	GASKET FOR 610447 ARROW FILT
23	2	605617	SPRING KIT, HYD FILTER 605615
24	1	605616	ELEMENT,25M HYD FILTER 605615

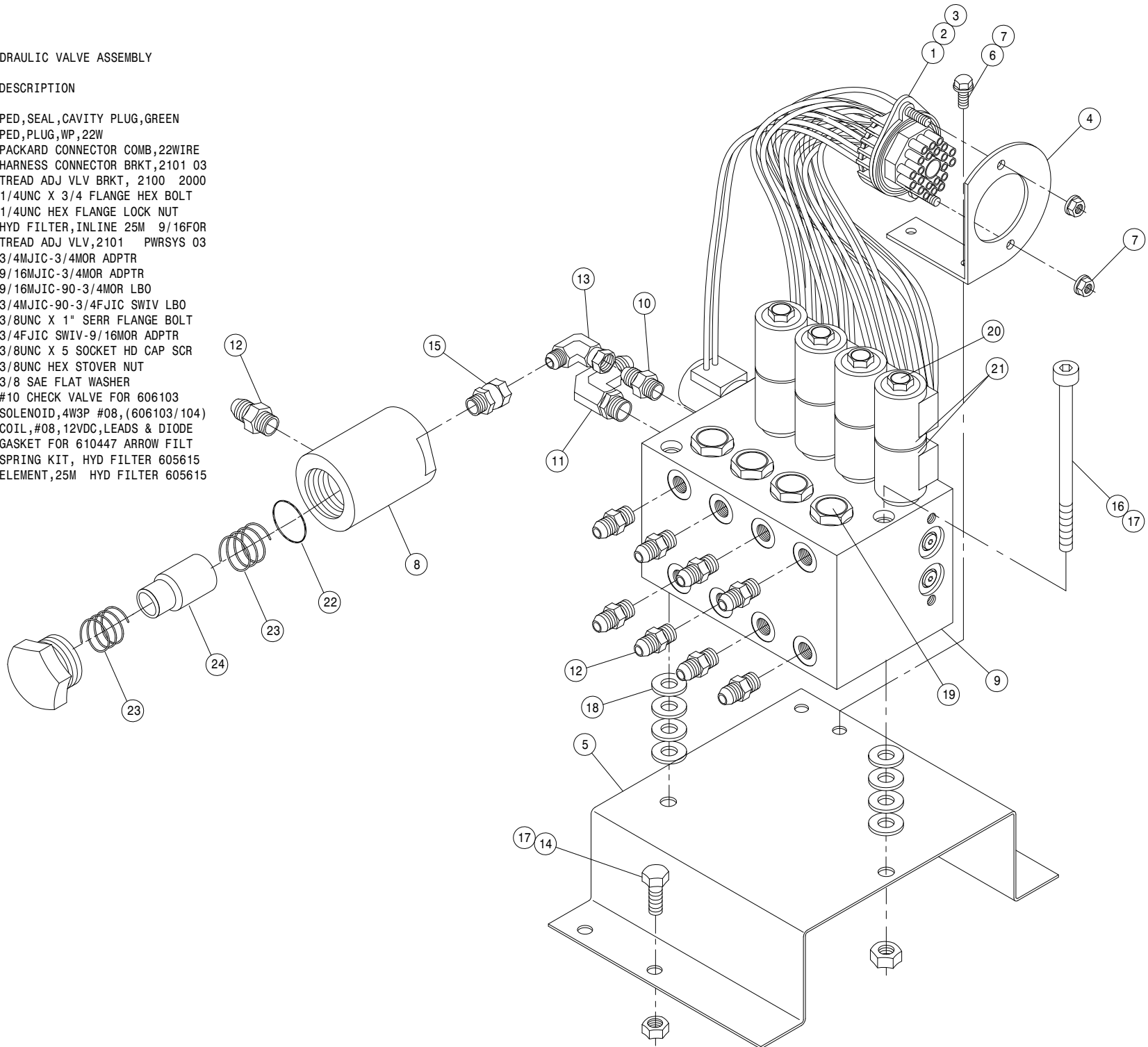

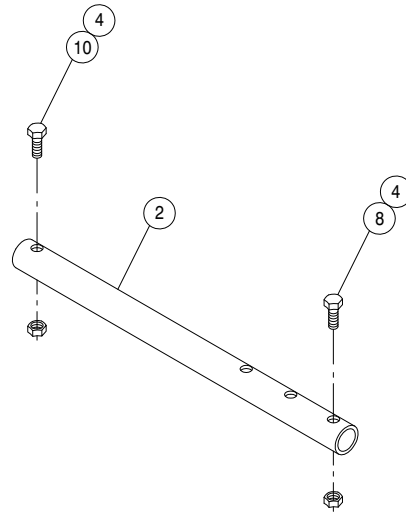
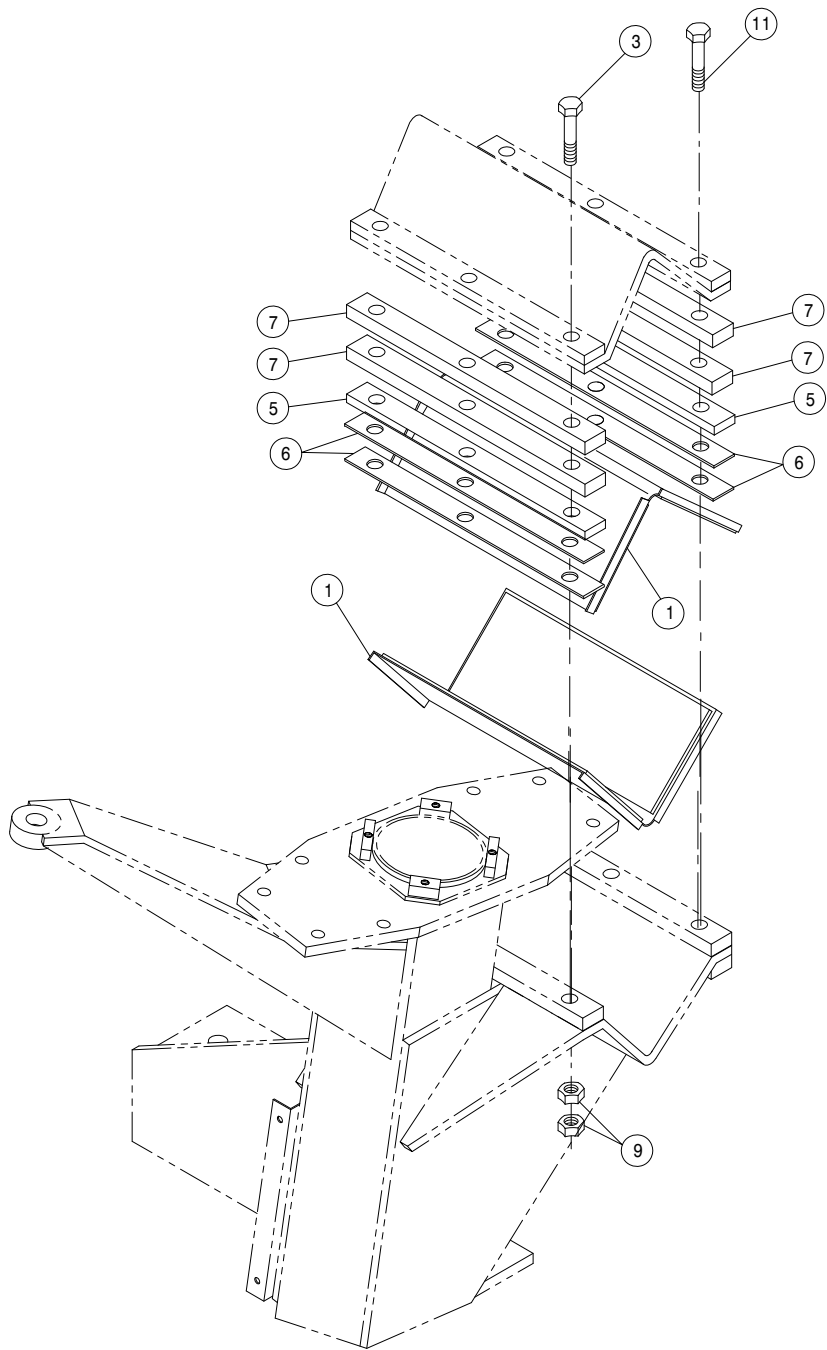

TREAD ADJUSTMENT ASSEMBLY

DET.	QTY	PART NO.	DESCRIPTION	
1	8	359294	TREAD ADJ XMBR BEARING ASSY 05	
2	4	358939	TREAD ADJ CYL EXT, 144" 2100 98	
3	12	900838	5/8UNF X 4" HEX BOLT GR8	
4	8	914008	1/2UNC HEX STOVER NUT	
5	8	358769	.250 LEG MT SHIM, 284T	94
6	16	358768	.037 LEG MT SHIM, 284T	94
7	16	358766	.375 LEG MT SPACER, 284T	94
8	4	900268	1/2UNC X 2 1/2 HEX BOLT	
9	48	914811	5/8UNF HEX NUT GR8	
10	4	900267	1/2UNC X 2" HEX BOLT	
11	12	900853	5/8UNF X 4 1/2 HEX BOLT GR8	

NOTE: QUANTITY LISTED IS FOR ONE MACHINE.

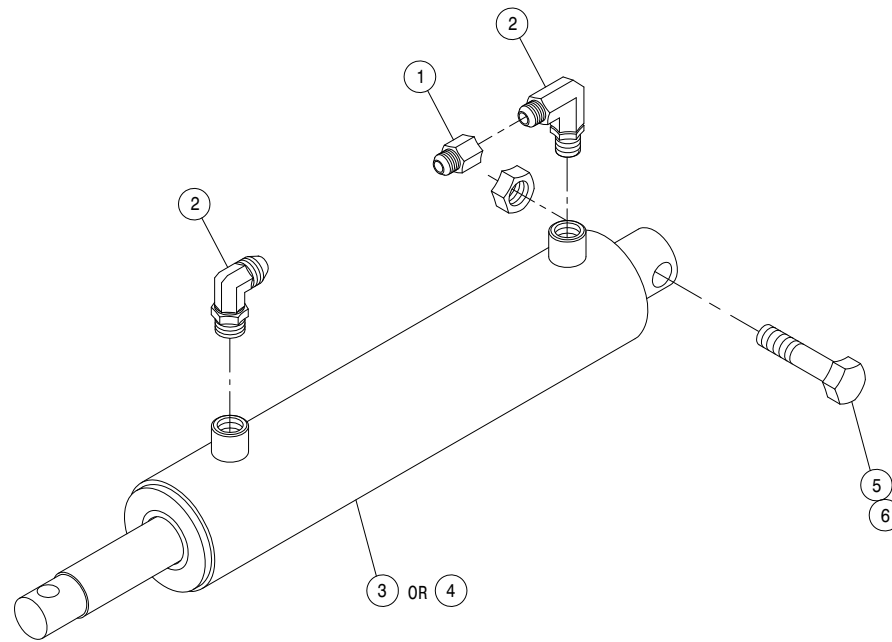

144" TREAD ADJUSTMENT LEG CYLINDER ASSEMBLY

DET. QTY PART NO. DESCRIPTION

1	1	618731	9/16JIC .025 ORIFICE ADPTR
2	2	618119	9/16MJIC-90-9/16MOR LBO
3	1	621536	HYD CYL, 2.50 X 12.00 X 1.250
4	1	621534	HYD CYL, 2.50 X 12.00 X 1.250
5	1	900268	1/2UNC X 2 1/2 HEX BOLT
6	1	914008	1/2UNC HEX STOVER NUT
NS	1	621527	REPAIR KIT, HYD CYL 621526

NOTE: 1. 621217 - RH LEG 144" TREAD ADJ CYLINDER ASSEMBLY WITH FITTINGS
 2. 621216 - LH LEG 144" TREAD ADJ CYLINDER ASSEMBLY WITH FITTINGS

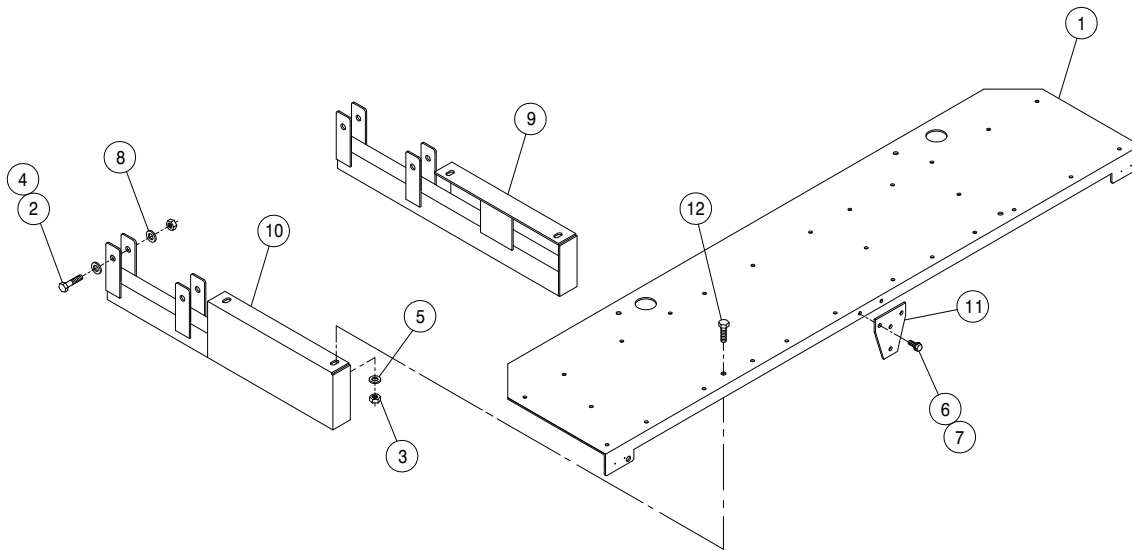

INJECTION SYSTEM PLATFORM OPTION

DET. QTY PART NO. DESCRIPTION

1	1	690637	INJ SYS PLATFORM WLD, 2100 99
2	4	900340	5/8UNC X 3 1/2 HEX BOLT
3	4	914008	1/2UNC HEX STOVER NUT
4	4	914010	5/8UNC HEX STOVER NUT
5	4	920004	1/2 SAE FLAT WASHER
6	2	470118	1/4UNC X 3/4 FLANGE HEX BOLT
7	2	470121	1/4UNC HEX FLANGE LOCK NUT
8	8	483037	5/8 REGULAR FLAT WASHER
9	1	690921	RH INJ PLATFORM MT WLD,2101 04
10	1	690922	LH INJ PLATFORM MT WLD,2101 04
11	1	690928	SMV BRKT,INJ PLATFORM, 2101 04
12	4	900264	1/2UNC X 1 1/4 HEX BOLT

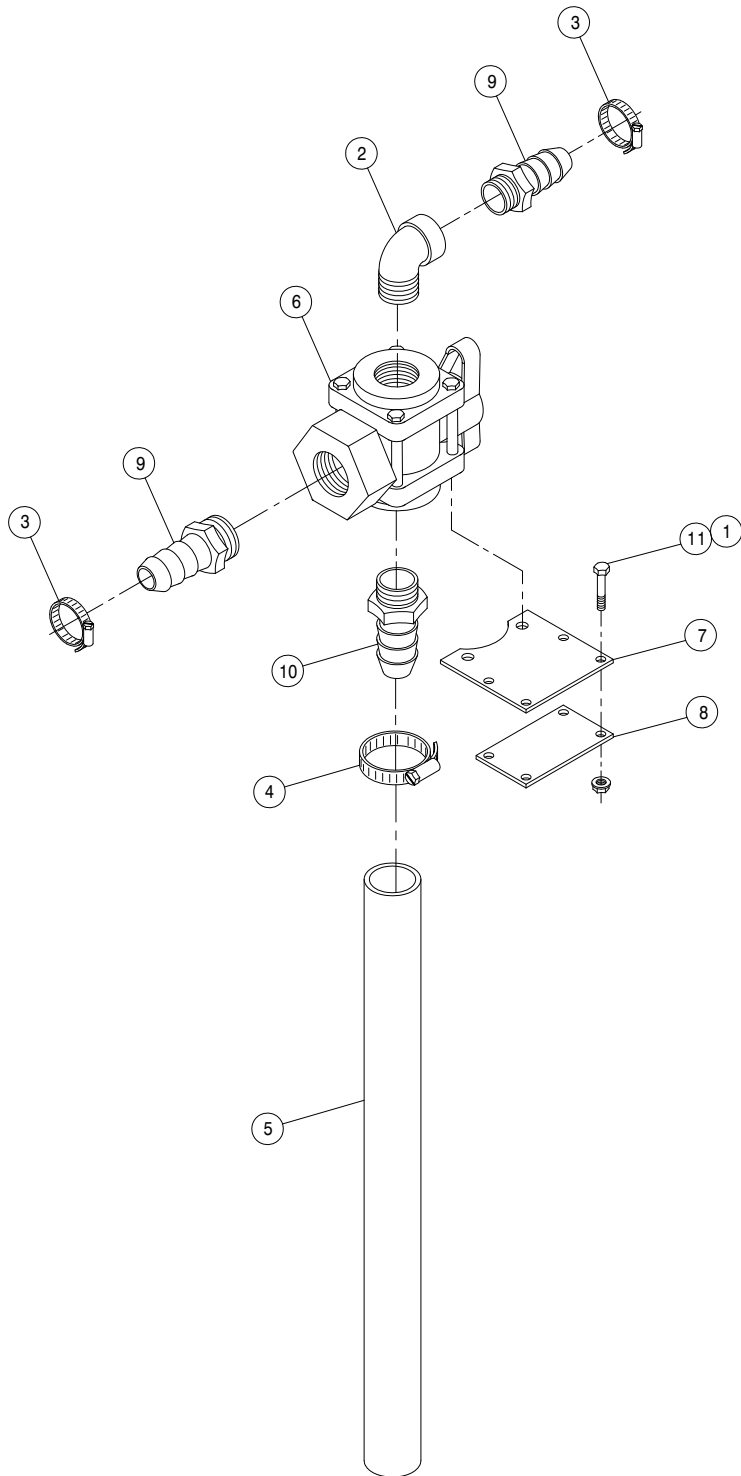

60' -80' FOAMER DIVERT VALVE OPTION

DET. QTY PART NO. DESCRIPTION

1	8	470121	1/4UNC HEX FLANGE LOCK NUT
2	2	500014	1"NPT-90 ST EL, POLY
3	4	520055	HOSE CLAMP NO 12 STAINLESS
4	2	520085	HOSE CLAMP NO 24 STAINLESS
5	2	601367	HOSE, 1 1/4 X 24 2BR BLK EPDM
6	2	696133	BALL VLV,1.00NP 3WAY-BOTT POLY
7	2	701152	FOAMER DIVERTER VALVE MT BRKT
8	2	701153	FOAMER DIVERTER VLV BRKT KEEPR
9	4	714331	1 NPT X 3/4 HOSE BARB
10	2	714561	1.00NPT-1.25 HOSE BARB
11	8	900007	1/4UNC X 2" HEX BOLT

NOTE: QUANTITY LISTED IS FOR ONE MACHINE.

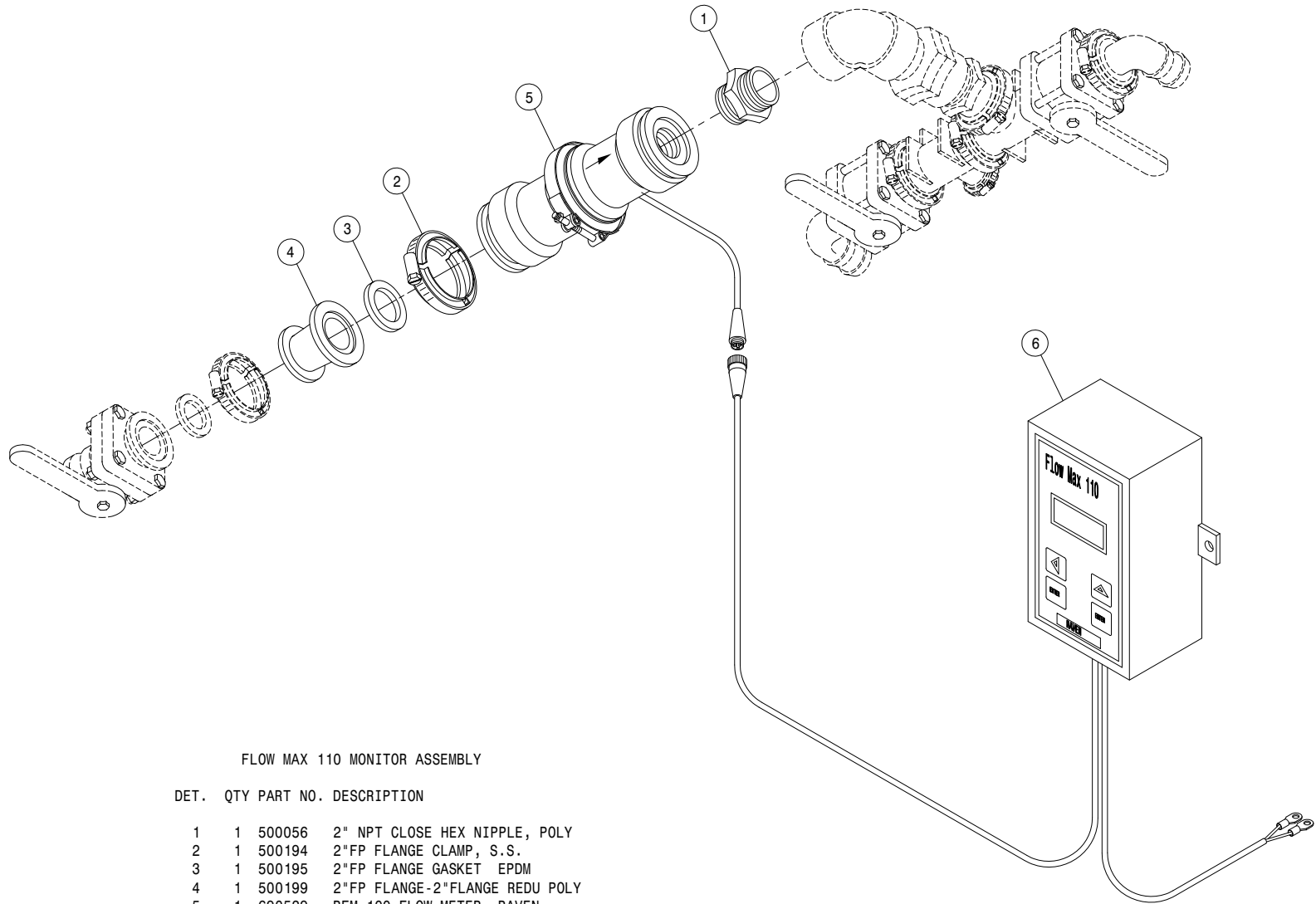

FLOW MAX 110 MONITOR ASSEMBLY

DET. QTY PART NO. DESCRIPTION

1	1	500056	2" NPT CLOSE HEX NIPPLE, POLY
2	1	500194	2"FP FLANGE CLAMP, S.S.
3	1	500195	2"FP FLANGE GASKET EPDM
4	1	500199	2"FP FLANGE-2"FLANGE REDU POLY
5	1	690529	RFM 100 FLOW METER, RAVEN
6	1	690804	FLOW MAX 110 CONSOLE, RAVEN

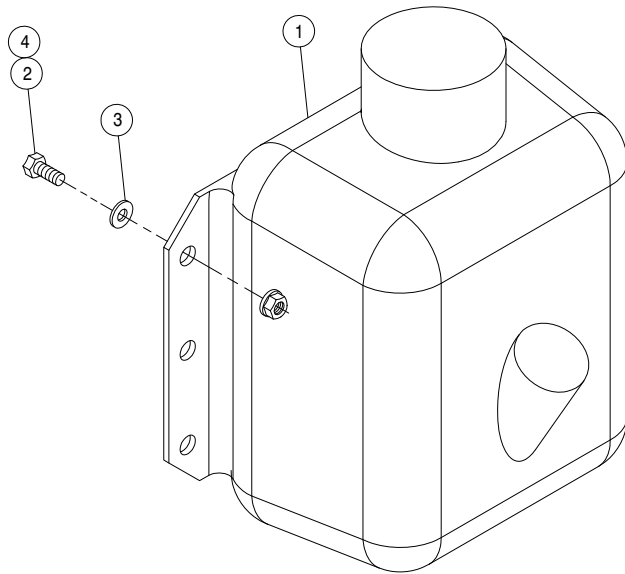

WINDSHIELD WASHER ASSEMBLY

DET. QTY PART NO. DESCRIPTION

1	1	470435	WINDSHIELD WIPER PKG DTS 10 05
2	4	900002	1/4UNC X 3/4 HEX BOLT
3	4	470212	1/4 BONDED SEALING WASH, SS
4	4	470121	1/4UNC HEX FLANGE LOCK NUT

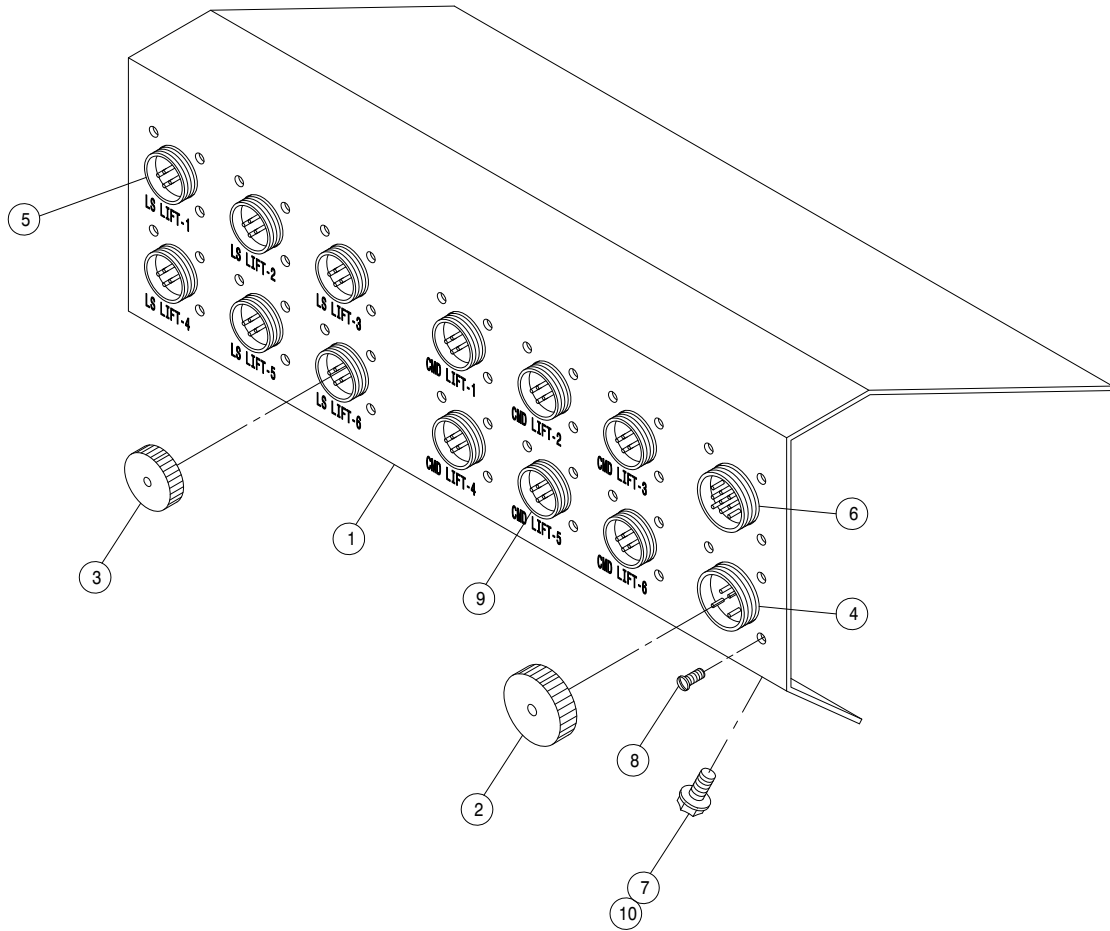

COMBO LS/DEPTH COMMAND RECEPTACLE ASSEMBLY

DET.	QTY	PART NO.	DESCRIPTION
1	1	002926	LS RECEPTACLE MT, 2100 COMBO
2	2	291688	AMP,COVER,SIZE 13
3	12	293046	AMP,COVER,SIZE 11
4	1	294007	5-6LS ELECT VLV HARNESS,DTS10C
5	6	293484	LS JUMPER WIRE ASSY,2100 COMBO
6	1	293485	MAIN LS ELECT VLV WIRE ASSY
7	3	470122	1/4UNC X 1/2 FLANGE HEX BOLT
8	56	473932	6-32 X 3/8 PAN SELF TAP SCR
9	6	293479	129" WIRE ASSY,DEPTH CMD JUMPR
10	3	470086	1/4UNC NUTSERT .020-.100 ALUM

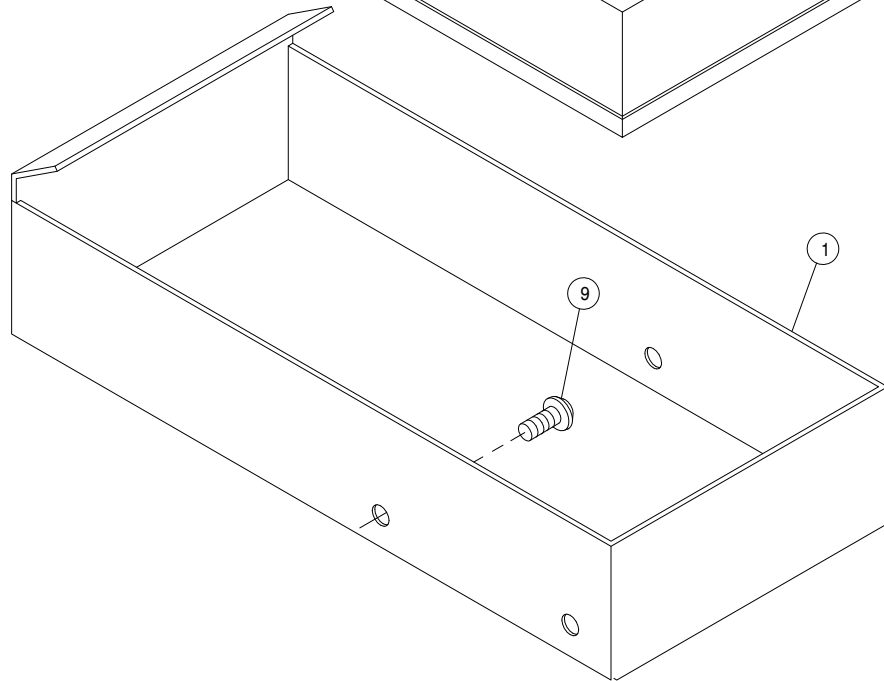
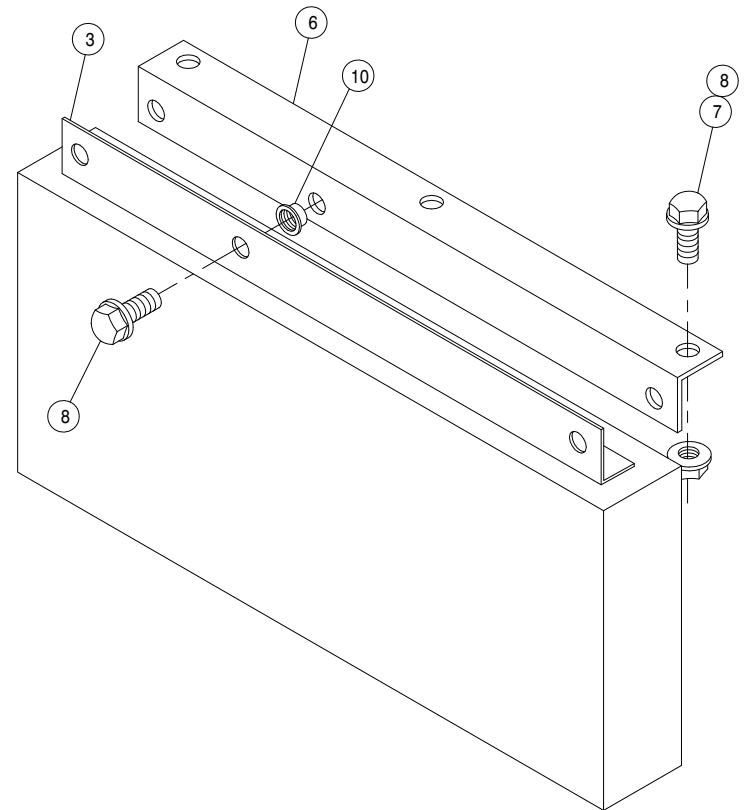
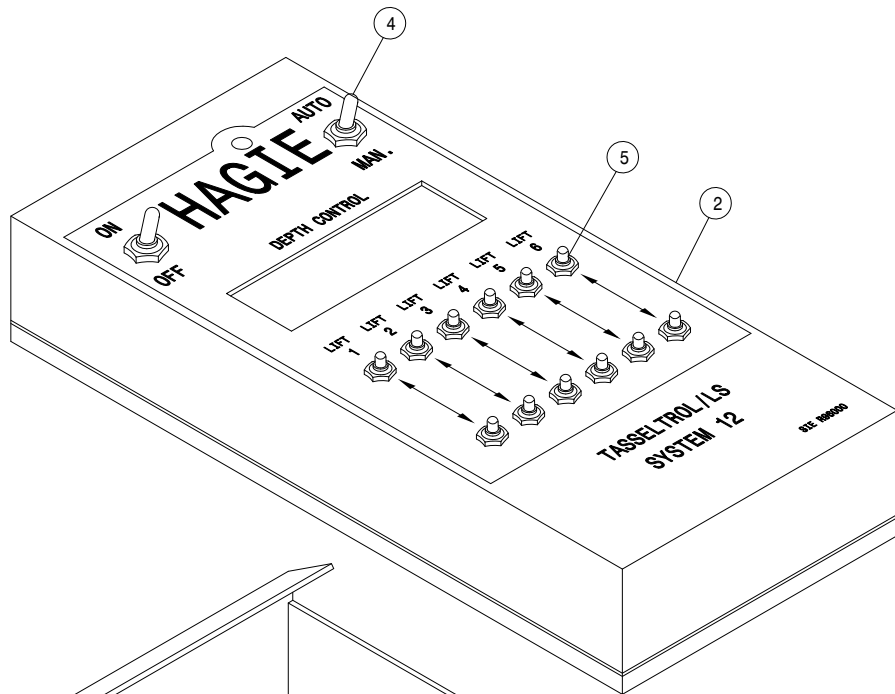

LS CONTROL BOX ASSEMBLY

DET. QTY PART NO. DESCRIPTION

1	1	002903	LS CTRL 6L DISPLAY MT
2	1	293373	LS CTRL 6L DISPLAY BOX ASSY
3	1	293906	TASSELTROL CABLE BOX ASSY 2008
4	2	470001	RUBBER BOOT W NUT FOR 298012
5	12	293255	SWITCH BOOT,PUSHBUTTON,1/4-40
6	1	002925	LS CTRL BOX MT, 2100 COMBO
7	3	470121	1/4UNC HEX FLANGE LOCK NUT
8	6	470122	1/4UNC X 1/2 FLANGE HEX BOLT
9	2	903708	1/4UNC X1/2PHIL PANHD MACH SCR
10	3	470086	1/4UNC NUTSERT .020-.100 ALUM

COMBO MOTOR CONTROL VALVE SWITCH ASSEMBLY

DET. QTY PART NO. DESCRIPTION

1	1	002924	SW BOX MT,6L DEPTH CMD2100CMBO
2	1	003208	MTR CTRL VLV SW BOX,DTS10C '10
3	1	298004	FUSE,AGC,20A GLASS
4	7	298012	TOGGLE SWITCH,ON-OFF,SPST,15A
5	1	298011	FUSE HOLDER
6	7	470001	RUBBER BOOT W NUT FOR 298012
7	4	473829	3MM-0.50 X 16MM PANHEAD SCREW
8	1	473914	GROMMET, .562ID .062GW .812GD
9	1	650273	DECAL,MASTER SWITCH,DTS10C '10
10	2	470122	1/4UNC X 1/2 FLANGE HEX BOLT
11	2	470121	1/4UNC HEX FLANGE LOCK NUT

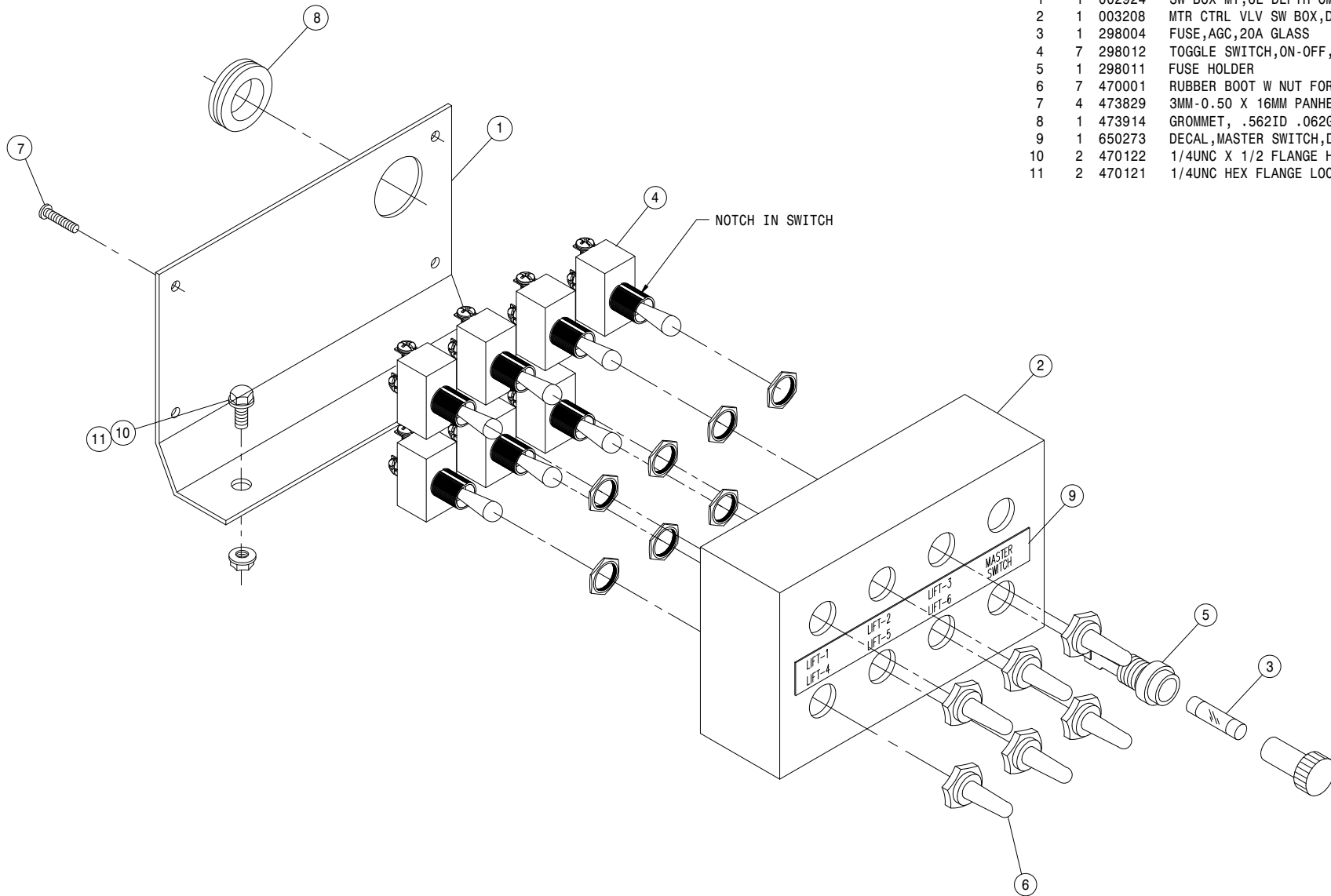

DEPTH COMMAND CONTROL BOX ASSEMBLY

DET. QTY PART NO. DESCRIPTION

DET.	QTY	PART NO.	DESCRIPTION
1	1	002896	SWITCH BOX, 5/6L DEPTH CMD 96
2	1	002924	SW BOX MT,6L DEPTH CMD2100CMB0
3	1	291602	FUSE,AGC,10A GLASS
4	6	293172	TOGGLE SWITCH DPDT W/JUMPERS
5	1	298011	FUSE HOLDER
6	6	470001	RUBBER BOOT W NUT FOR 298012
7	4	473829	3MM-0.50 X 16MM PANHEAD SCREW
8	1	473914	GROMMET, .562ID .062GW .812GD
9	1	650338	DECAL,DEPTH CMD 6-LIFT
10	2	470122	1/4UNC X 1/2 FLANGE HEX BOLT
11	2	470121	1/4UNC HEX FLANGE LOCK NUT

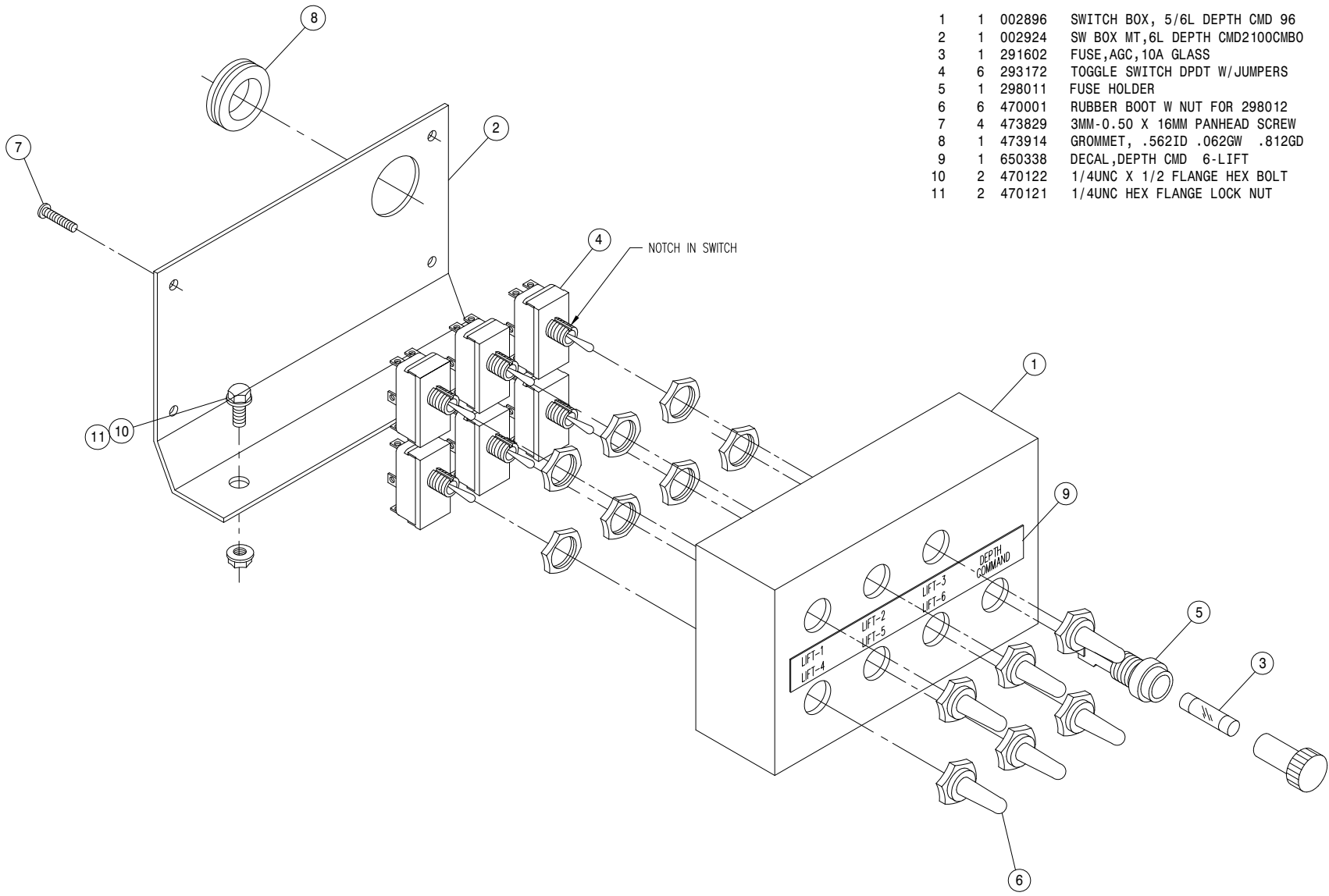

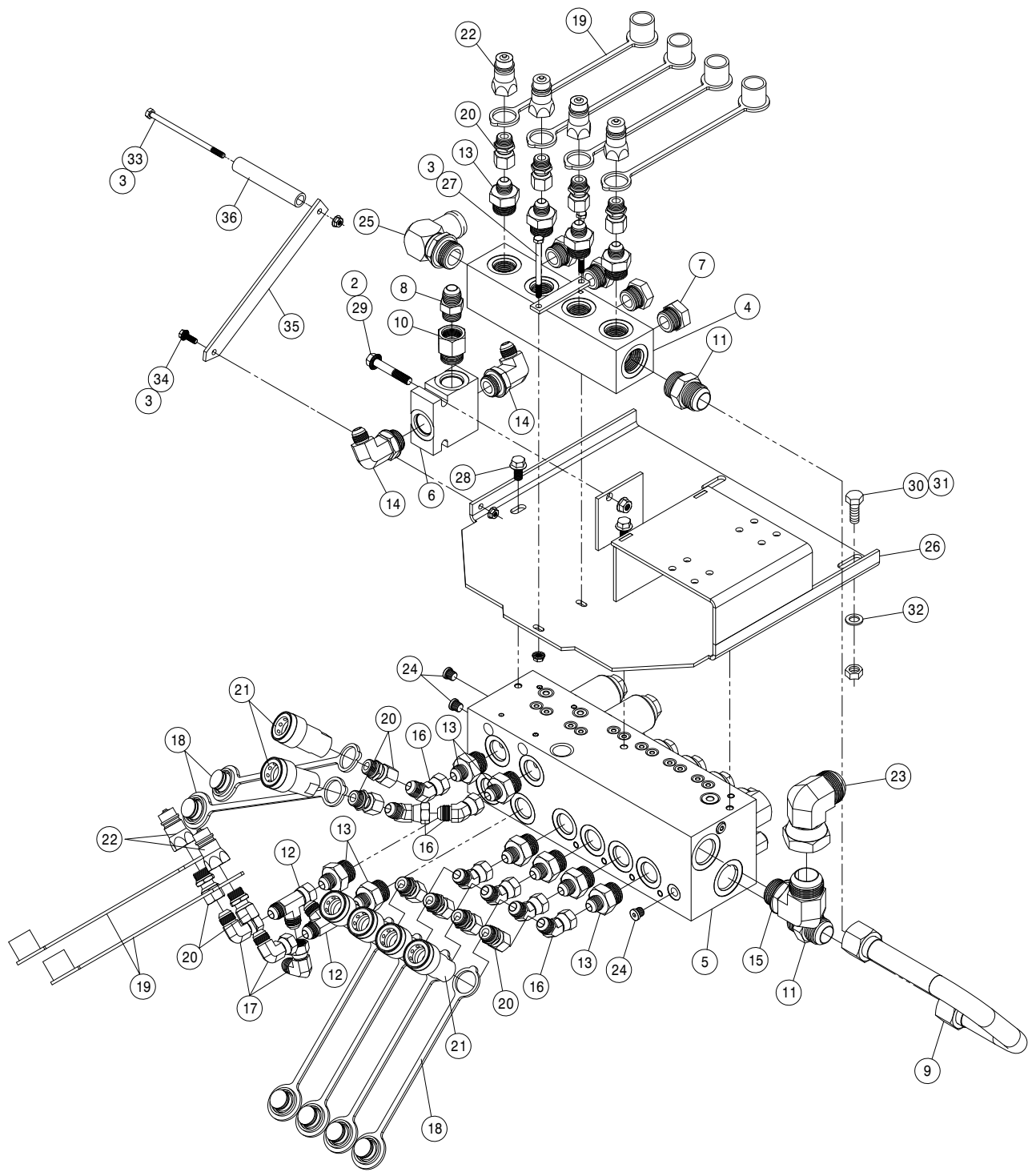

MOTOR CONTROL VALVE ASSEMBLY

DET.	QTY	PART NO.	DESCRIPTION
1	1	439116	MTR CTRL VLV MT KEEPER, 204 07
2	1	470087	3/8UNC HEX FLANGE LOCK NUT
3	4	470121	1/4UNC HEX FLANGE LOCK NUT
4	1	606029	RETURN MANIFOLD BLOCK, STS 03
5	1	606262	MTR CONTROL ELECT VLV, SAUER 07
6	1	606356	1 1/16FOR MANIFOLD, 3 #12PORTS
7	4	610186	1 1/16MOR PLUG, HEX HEAD
8	1	611126	7/8MJIC-7/8MOR ADPTR
9	1	615812	MTR CTRL RET TUBE ASSY, DTS10
10	1	618132	1 1/16MOR-7/8FOR ADPTR
11	2	618186	1 5/16MJIC-1 5/16MOR ADPTR
12	2	618451	3/4FJIC SW RUN TEE-3/4MJIC
13	12	618469	3/4MJIC-1 1/16MOR ADPTR
14	2	618474	3/4MJIC-90-1 1/16MOR LBO
15	1	618476	1 5/8MJIC-90-1 5/16MOR LBO
16	7	618590	3/4MJIC-45-3/4FJIC SWIV LBO
17	3	618609	3/4MJIC-90-3/4FJIC SWIV LBO
18	6	618635	RUBBER DUST PLUG, 618621/696
19	6	618636	RUBBER DUST CAP, 618622/697
20	12	618669	3/4FJIC SWIV-3/4MOR ADPTR
21	6	618696	HYD COUPLER, FEM 1/2B, 3/4FOR
22	6	618697	HYD COUPLER, MALE 1/2B, 3/4FOR
23	1	618721	1 5/8MJ-90-1 5/8FJ SWIV LBO
24	3	618753	7/16MOR PLUG, HEX SOCKET
25	1	618772	1 1/4 HOSE BARB-90-1 5/16MOR
26	1	691102	SOLU PUMP MT PLT WLD, DTS10C '10
27	2	900011	1/4UNC X 3 1/4 HEX BOLT
28	3	900128	3/8UNC X 3/4 HEX BOLT
29	1	900170	3/8UNC X 2 1/4 SER FLANGE BOLT
30	3	900129	3/8UNC X 1" SERR FLANGE BOLT
31	3	914004	3/8UNC HEX STOVER NUT
32	3	920002	3/8 SAE FLAT WASHER
33	1	900027	1/4UNC X 5" HEX BOLT
34	1	470118	1/4UNC X 3/4 FLANGE HEX BOLT
35	1	691107	SOL PUMP WLD STRAP DTS10C '10
36	1	691108	.750 OD X 11GA X 4.33 C/L

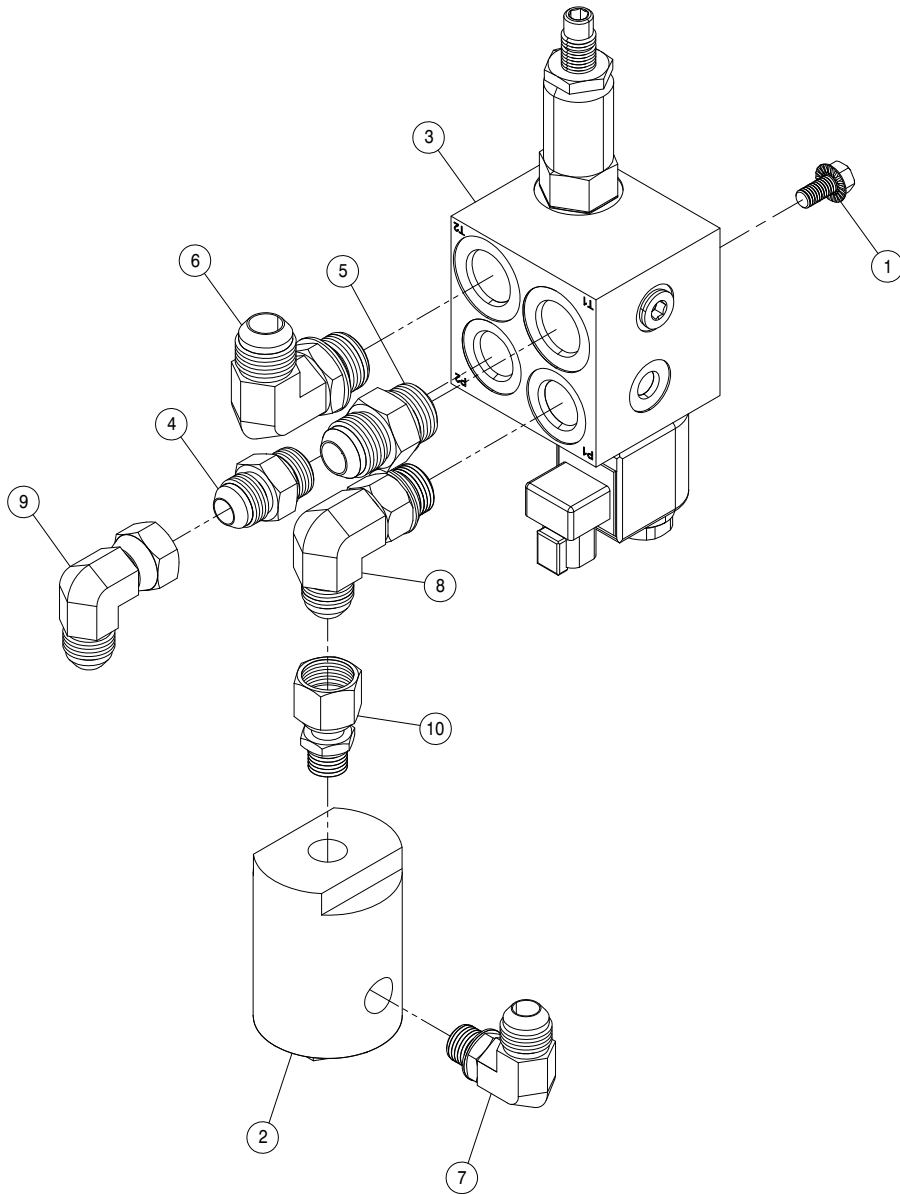

DUMP VALVE ASSEMBLY

DET.	QTY	PART NO.	DESCRIPTION
1	2	900128	3/8UNC X 3/4 HEX BOLT
2	1	605615	HYD FILTER, INLINE 25M 9/16FOR
3	1	606330	DUMP MANIF VALVE SAUER
4	1	611125	3/4MJIC-3/4MOR ADPTR
5	1	611126	7/8MJIC-7/8MOR ADPTR
6	1	611128	7/8MJIC-90-7/8MOR LBO
7	1	618249	3/4MJIC-90-9/16MOR LBO
8	1	618464	3/4MJIC-90-3/4MOR LG LBO
9	1	618609	3/4MJIC-90-3/4FJIC SWIV LBO
10	1	618692	3/4FJIC SWIV-9/16MOR ADPTR

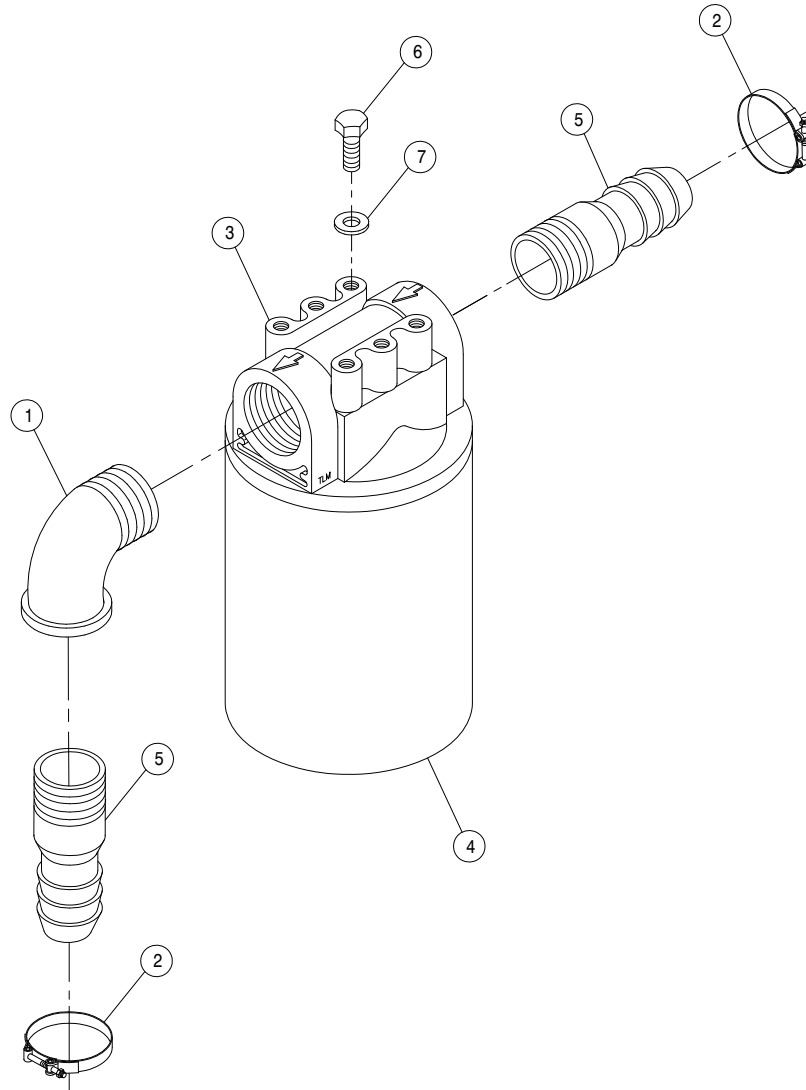

DETASSELER OPTION FILTER ASSEMBLY

DET.	QTY	PART NO.	DESCRIPTION
	1	506410	BLK PIPE ST EL 90DEG 1.25NPT
	2	520132	1.62/1.87 T-BOLT HOSE CLAMP SS
	3	605633	PARKER FILTER ASSY,25M,1.25NPT
	4	605634	PARKER FILTER ELEMENT,25MICRON
	5	715660	HOSE BARB 1 1/4NPT X 1 1/4
	6	900062	5/16UNC X 1/2 HEX BOLT
	7	920501	5/16 LOCK WASHER

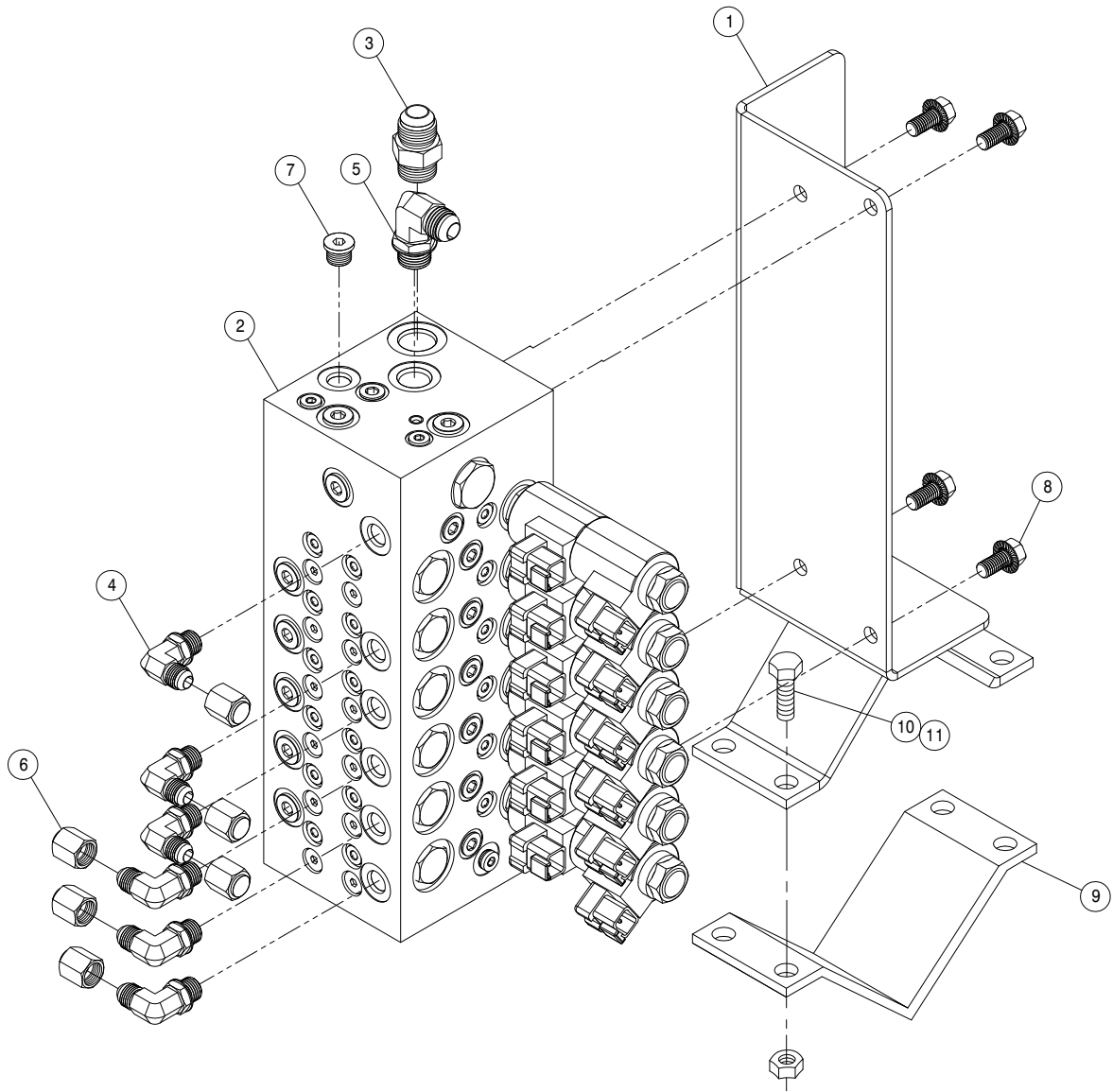

LIFT VALVE ASSEMBLY

DET.	QTY	PART NO.	DESCRIPTION
1	1	003115	LIFT VLV MT WLD,DTS10 COMBO'10
2	1	606285	LIFT VALVE,STS COMBO,SAUER
3	1	611126	7/8MJIC-7/8MOR ADPTR
4	6	618119	9/16MJIC-90-9/16MOR LBO
5	1	618241	3/4MJIC-90-3/4MOR LBO
6	6	618531	9/16FJIC CAP NUT
7	1	618754	9/16MOR PLUG, HEX SOCKET
8	4	900128	3/8UNC X 3/4 HEX BOLT
9	1	438324	75IN OUTRGR BRACE CLAMP
10	4	900265	1/2UNC X 1 1/2 HEX BOLT
11	4	914008	1/2UNC HEX STOVER NUT

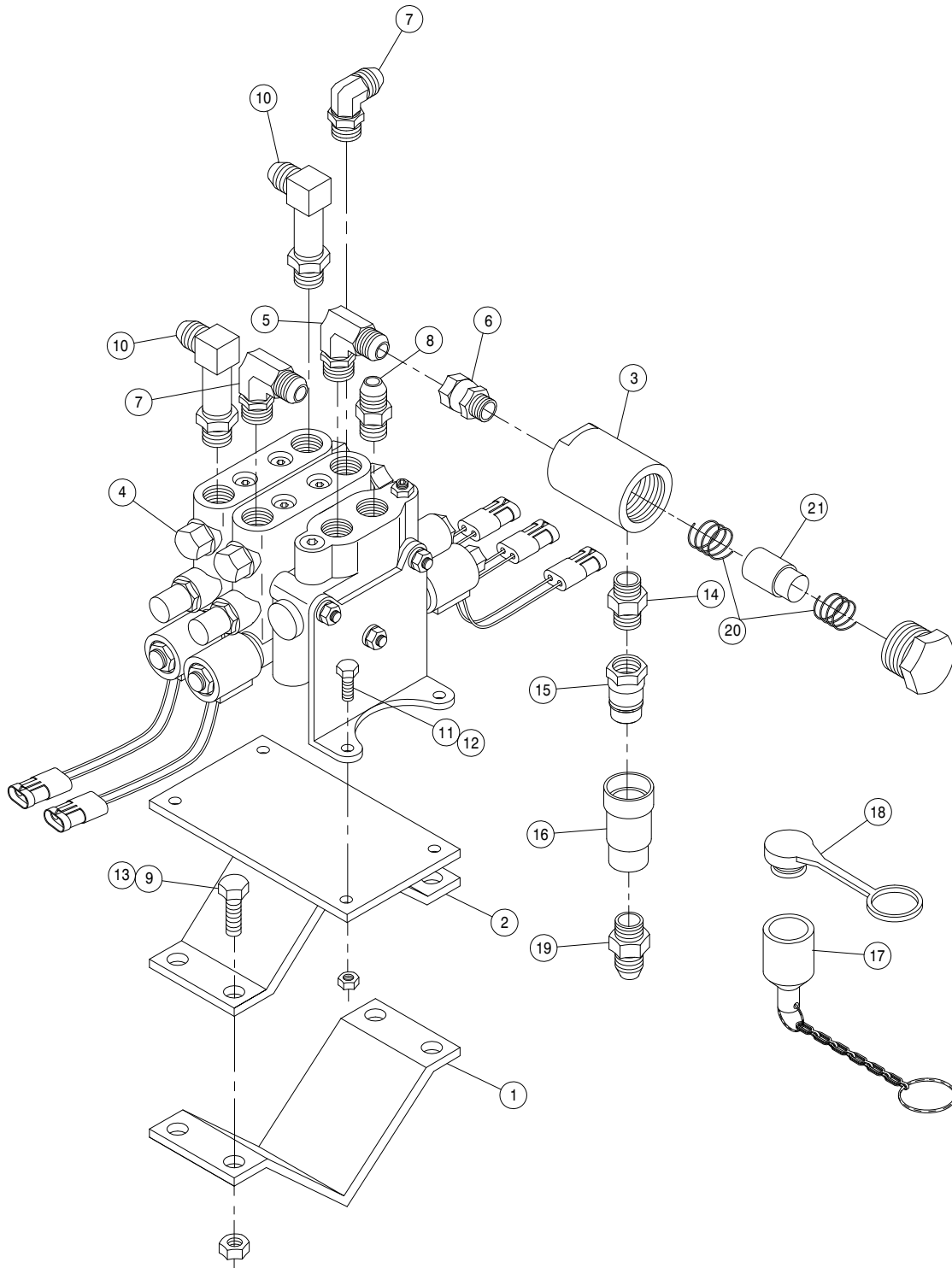

OUTRIGGER FOLD VALVE ASSEMBLY

DET.	QTY	PART NO.	DESCRIPTION
	1	438324	75IN OUTRGR BRACE CLAMP
	1	438724	OUTRGR FOLD VLV MT WLD2100/STS
	1	605615	HYD FILTER, INLINE 25M 9/16FOR
	1	606090	BRAND HYD VALVE, 2-SECT SER 36
	1	618183	3/4MJIC-90-7/8MOR LBO
	1	618692	3/4FJIC SWIV-9/16MOR ADPTR
	2	618115	9/16MJIC-90-3/4MOR LBO
	1	618327	3/4MJIC-7/8MOR ADPTR
	4	900265	1/2UNC X 1 1/2 HEX BOLT
	2	618709	9/16MJIC-90-3/4MOR EX LG LBO
	4	900065	5/16UNC X 1" HEX BOLT
	4	914002	5/16UNC HEX STOVER NUT
	4	914008	1/2UNC HEX STOVER NUT
	1	618345	9/16MOR-3/8MNPT ADPTR
	1	618646	HYD QUICK CPLR, MALE .375NPS
	1	618645	HYD QUICK CPLR, FEMALE .375NPS
	1	618648	RUBBER DUST CAP, 3/8 (618646)
	1	618647	RUBBER DUST PLUG, 3/8 (618645)
	1	618011	9/16MJIC-3/8MNPT ADPTR
	1	605616	ELEMENT, 25M HYD FILTER 605615
	1	605617	SPRING KIT, HYD FILTER 605615

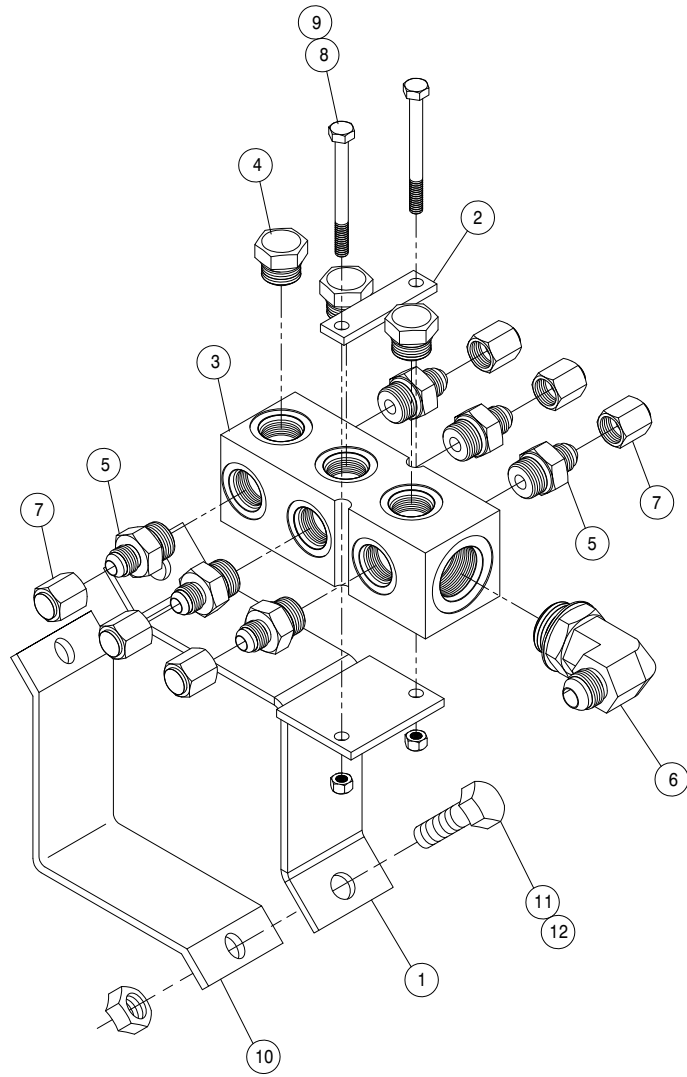

CASE DRAIN MANIFOLD ASSEMBLY

DET.	QTY	PART NO.	DESCRIPTION
1	1	438726	CUTTER RETURN MANIFOLD MT WLD
2	1	438729	CUTTER RETURN MANIF MT KEEPER
3	1	606021	HYD RETURN MANIF,3/4FOR,9-PORT
4	3	611159	3/4MOR PLUG, HEX HEAD
5	6	618109	9/16MJIC-3/4MOR ADPTR
6	1	618474	3/4MJIC-90-1 1/16MOR LBO
7	6	618531	9/16FJIC CAP NUT
8	2	900009	1/4UNC X 2 3/4 HEX BOLT
9	2	914000	1/4UNC HEX STOVER NUT
10	1	438727	CUTTER RETURN MANIF MT V-PLT
11	2	900264	1/2UNC X 1 1/4 HEX BOLT
12	2	914008	1/2UNC HEX STOVER NUT

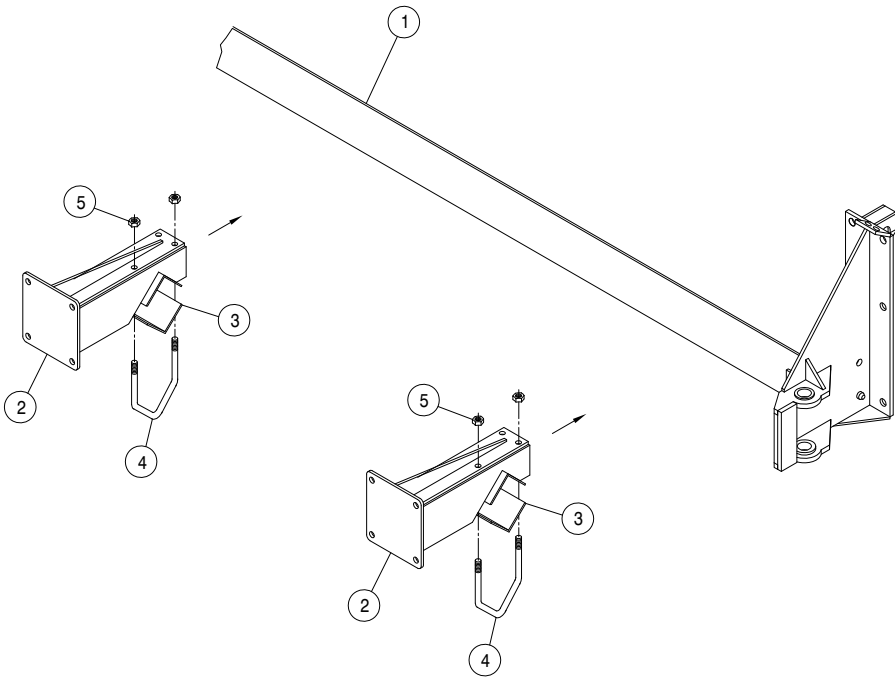

4-ROW 2-LIFT COMBO OUTRIGGER ASSEMBLY

DET. QTY PART NO. DESCRIPTION

1	1	438695	TOOLBAR WLD, 2100-ST512 COMBO
2	2	438762	16"HOIST COL ADPTR WLD, 204 04
3	2	438292	TOOL BAR V-PLT WLD 8200 86
4	4	438293	5/8UNC X 6 1/4 CTR U-BOLT TRI
5	8	914010	5/8UNC HEX STOVER NUT

NOTE: QUANTITY LISTED IS FOR ONE MACHINE.

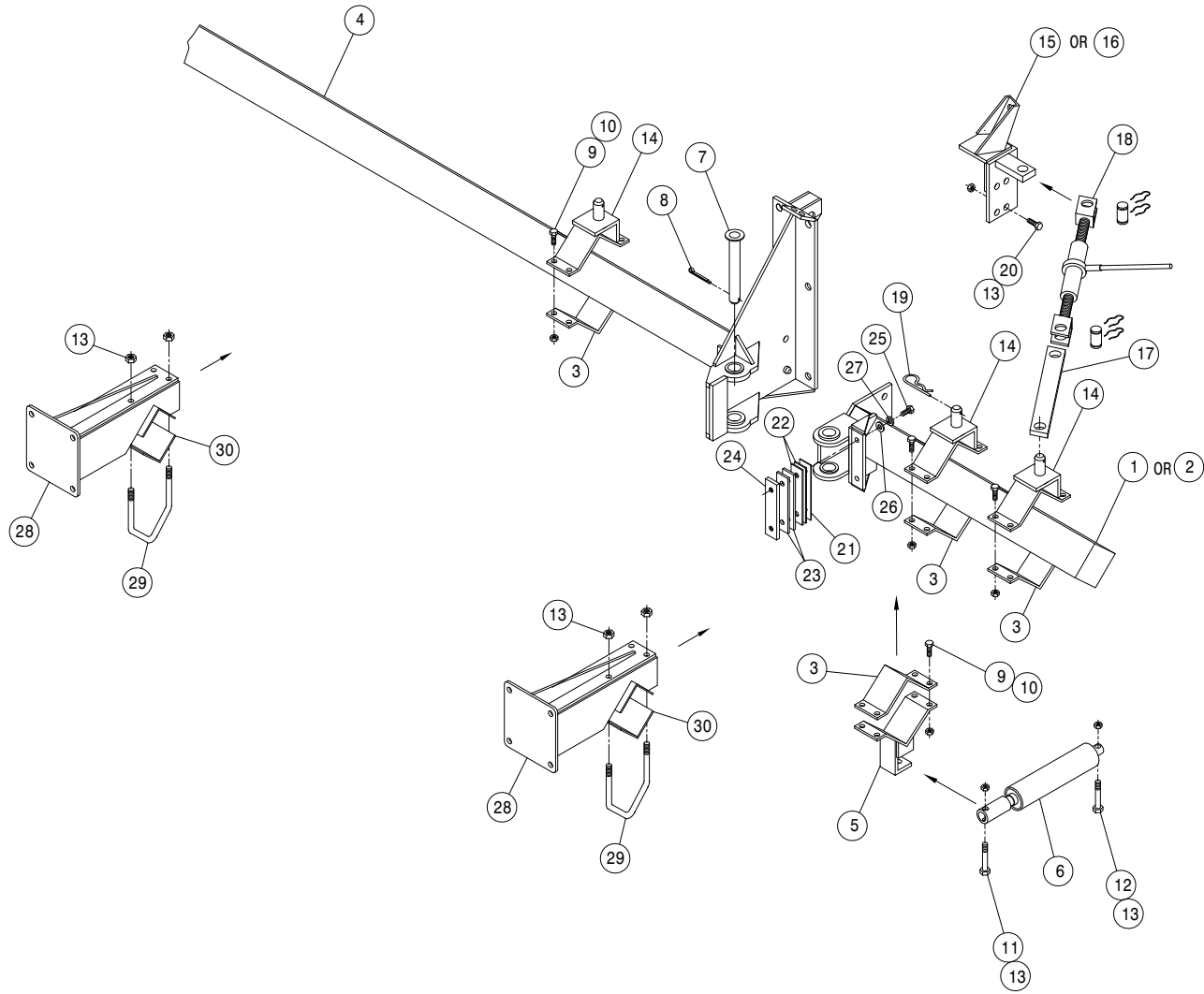

6-ROW 3-LIFT COMBO OUTRIGGER ASSEMBLY

DET.	QTY	PART NO.	DESCRIPTION
1	1	438705	RH 32IN OUTGR WLD 2100-ST512
2	1	438706	LH 32IN OUTGR WLD 2100-ST512
3	8	438324	75IN OUTGR BRACE CLAMP
4	1	438695	TOOLBAR WLD, 2100-ST512 COMBO
5	2	438610	OUTGR CYL MT WLD, 2100 COMBO
6	2	621209	OUTGR FOLD CYL ASSY,2100C 04
7	2	438283	OUTGR PIVOT PIN WLD 8200 86
8	2	470117	COTTER PIN 3/16 1 3/4 SQ CUT
9	32	900265	1/2UNC X 1 1/2 HEX BOLT
10	32	914008	1/2UNC HEX STOVER NUT
11	2	900338	5/8UNC X 3" HEX BOLT
12	2	900343	5/8UNC X 4 1/2 HEX BOLT
13	20	914010	5/8UNC HEX STOVER NUT
14	6	438397	STABILIZER PIN MT WLD 90
15	1	438651	RH OUTGR SUPP MT WLD,2100CMB0
16	1	438652	LH OUTGR SUPP MT WLD,2100CMB0
17	1	438656	OUTGR TRANSPORT BAR,2100COMBO
18	1	470299	RATCHET JACK LOAD-BINDER
19	4	611016	HAIR PIN #6
20	4	900334	5/8UNC X 1 3/4 HEX BOLT
21	2	438700	TOOLBAR STOP SHIM, 16GA (.060)
22	4	438701	TOOLBAR STOP SHIM, 14GA (.075)
23	4	438702	TOOLBAR STOP SHIM, 11GA (.120)
24	2	438703	TOOLBAR STOP, 2100-ST512 COMBO
25	4	900130	3/8UNC X 1 1/4 SER FLANGE BOLT
26	4	920002	3/8 SAE FLAT WASHER
27	4	920502	3/8 LOCK WASHER
28	3	438762	16"HOIST COL ADPTR WLD, 204 04
29	6	438293	5/8UNC X 6 1/4 CTR U-BOLT TRI
30	3	438292	TOOL BAR V-PLT WLD 8200 86

NOTE: QUANTITY LISTED IS FOR ONE MACHINE.

8-10 ROW 4-LIFT COMBO OUTRIGGER ASSEMBLY

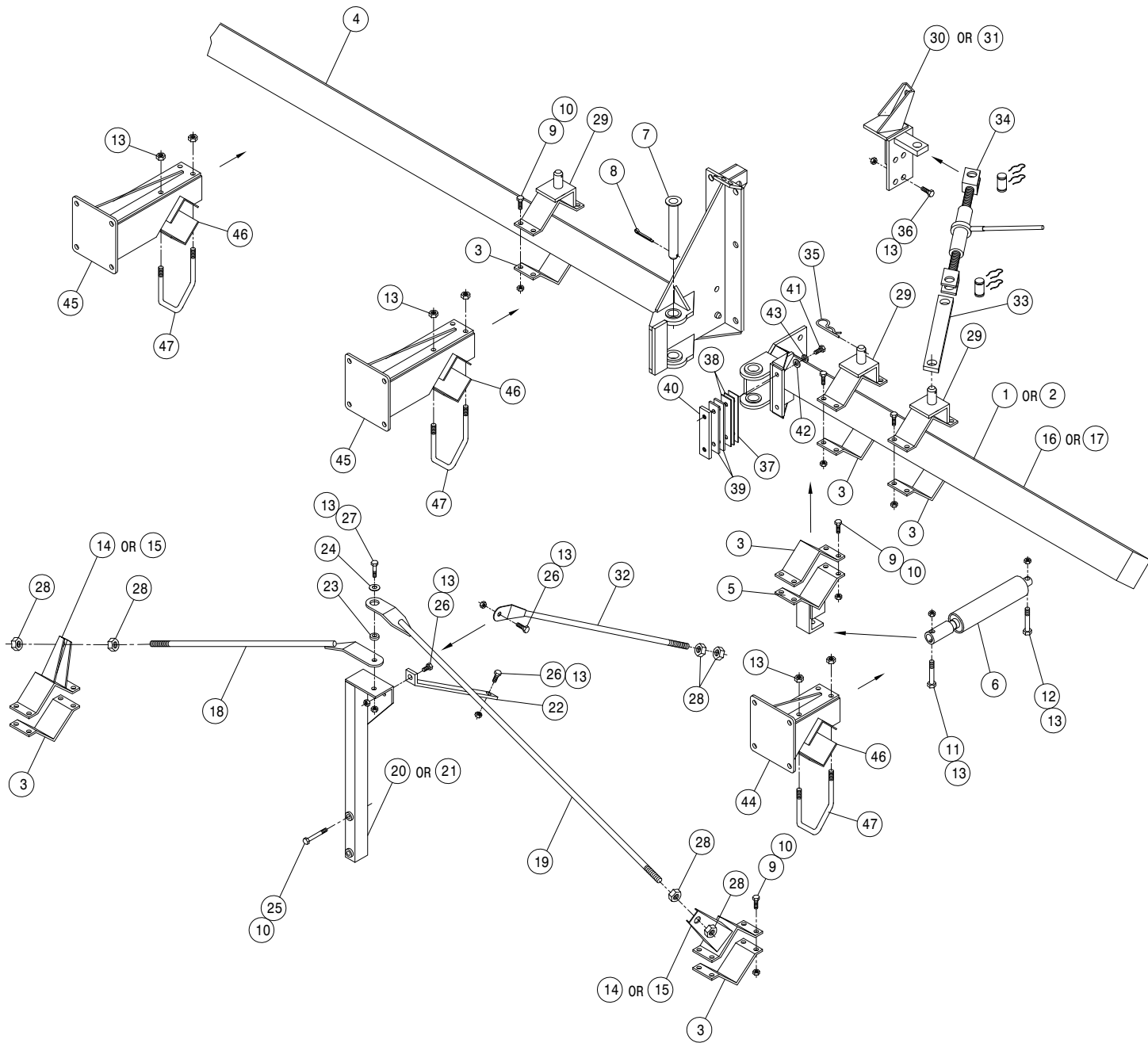

DET.	QTY	PART NO.	DESCRIPTION
1	1	438707	RH 75IN OUTGR WLD 2100-ST512
2	1	438708	LH 75IN OUTGR WLD 2100-ST512
3	12	438324	75IN OUTGR BRACE CLAMP
4	1	438695	TOOLBAR WLD, 2100-ST512 COMBO
5	2	438610	OUTGR CYL MT WLD, 2100 COMBO
6	2	621209	OUTGR FOLD CYL ASSY,2100C 04
7	2	438283	OUTGR PIVOT PIN WLD 8200 86
8	2	470117	COTTER PIN 3/16 1 3/4 SQ CUT
9	48	900265	1/2UNC X 1 1/2 HEX BOLT
10	52	914008	1/2UNC HEX STOVER NUT
11	2	900338	5/8UNC X 3" HEX BOLT
12	2	900343	5/8UNC X 4 1/2 HEX BOLT
13	32	914010	5/8UNC HEX STOVER NUT
14	2	438362	RH OUTGR CLAMP WLD 200 89
15	2	438363	LH OUTGR CLAMP WLD 200 89
16	1	438709	RH 101IN OUTGR WLD 2100-ST512
17	1	438710	LH 101IN OUTGR WLD 2100-ST512
18	2	438664	OUTGR TIE BAR WLD 72"2100/STS
19	2	438544	OUTGR SUPP ROD WLD 50"10/12R
20	1	438595	RH OUTGR SUPP POST WLD284C 97
21	1	438596	LH OUTGR SUPP POST WLD284C 97
22	2	438609	OUTGR SUPP BRACE, 2100 COMBO
23	2	438541	BUSH,1.00 OD- .656 ID- .53 LG
24	2	483037	5/8 REGULAR FLAT WASHER
25	4	900271	1/2UNC X 3 1/4 HEX BOLT
26	6	900333	5/8UNC X 1 1/2 HEX BOLT
27	2	900352	5/8UNC X 2 1/4 HEX BOLT
28	12	910012	3/4UNC HEX NUT
29	6	438397	STABILIZER PIN MT WLD 90
30	1	438651	RH OUTGR SUPP MT WLD,2100CMBO
31	1	438652	LH OUTGR SUPP MT WLD,2100CMBO
32	2	438654	TOOLBAR SUPP ROD WLD,2100COMBO
33	2	438656	OUTGR TRANSPORT BAR,2100COMBO
34	2	470299	RATCHET JACK LOAD-BINDER
35	4	611016	HAIR PIN #6
36	4	900334	5/8UNC X 1 3/4 HEX BOLT
37	2	438700	TOOLBAR STOP SHIM, 16GA (.060)
38	4	438701	TOOLBAR STOP SHIM, 14GA (.075)
39	4	438702	TOOLBAR STOP SHIM, 11GA (.120)
40	2	438703	TOOLBAR STOP, 2100-ST512 COMBO
41	4	900130	3/8UNC X 1 1/4 SER FLANGE BOLT
42	4	920002	3/8 SAE FLAT WASHER
43	4	920502	3/8 LOCK WASHER
44	2	438757	8" HOIST COL ADPTR WLD, 204 04
45	2	438762	16"HOIST COL ADPTR WLD, 204 04
46	4	438292	TOOL BAR V-PLT WLD 8200 86
47	8	438293	5/8UNC X 6 1/4 CTR U-BOLT TRI

NOTE: QUANTITY LISTED IS FOR ONE MACHINE.

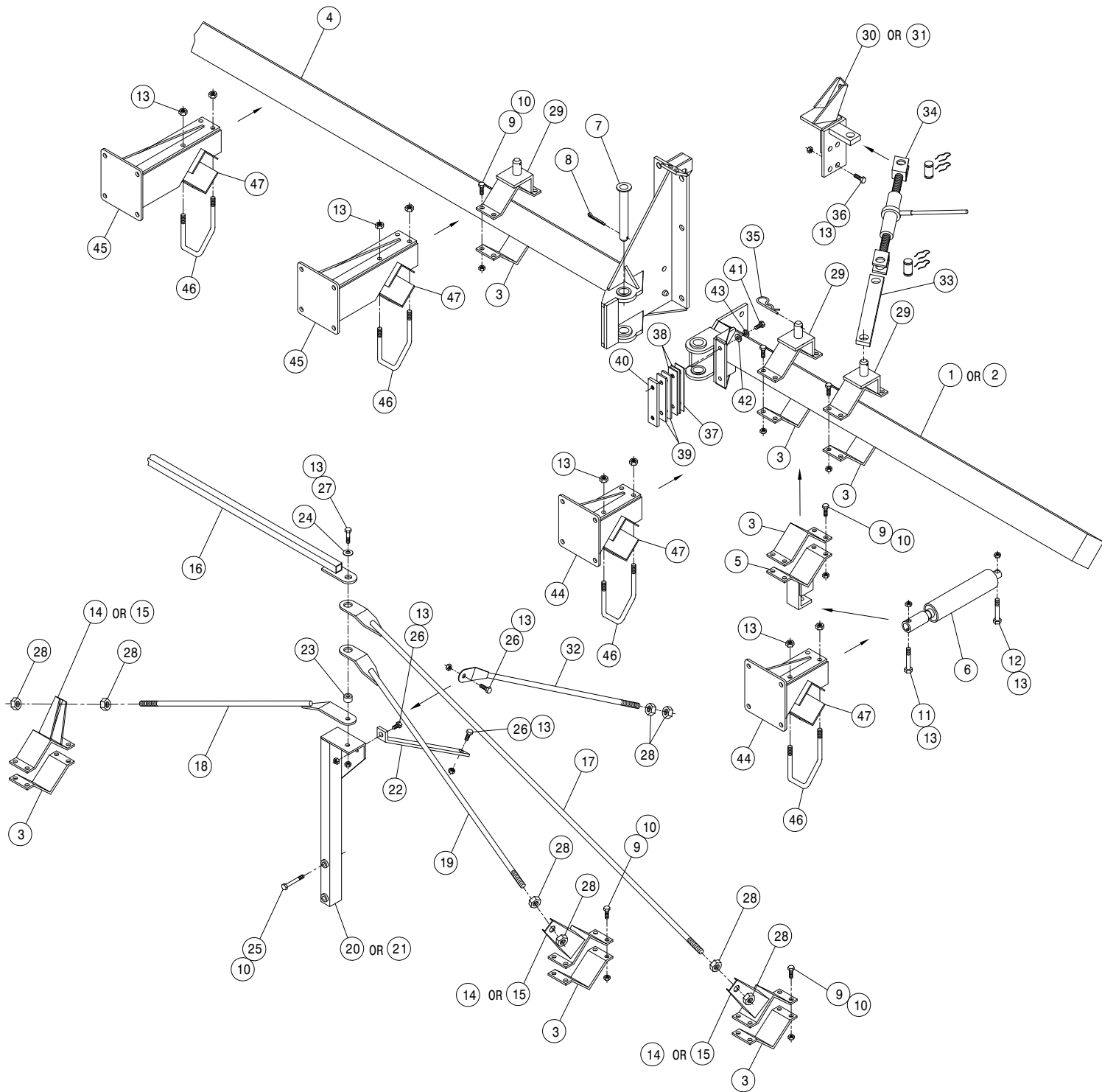

12-ROW 6-LIFT COMBO OUTRIGGER ASSEMBLY

DET.	QTY	PART NO.	DESCRIPTION
1	1	438711	RH 133IN OUTGR WLD 2100-ST512
2	1	438712	LH 133IN OUTGR WLD 2100-ST512
3	14	438324	75IN OUTGR BRACE CLAMP
4	1	438695	TOOLBAR WLD, 2100-ST512 COMBO
5	2	438610	OUTGR CYL MT WLD, 2100 COMBO
6	2	621209	OUTGR FOLD CYL ASSY,2100C 04
7	2	438283	OUTGR PIVOT PIN WLD 8200 86
8	2	470117	COTTER PIN 3/16 1 3/4 SQ CUT
9	56	900265	1/2UNC X 1 1/2 HEX BOLT
10	60	914008	1/2UNC HEX STOVER NUT
11	2	900338	5/8UNC X 3" HEX BOLT
12	2	900343	5/8UNC X 4 1/2 HEX BOLT
13	40	914010	5/8UNC HEX STOVER NUT
14	3	438362	RH OUTGR CLAMP WLD 200 89
15	3	438363	LH OUTGR CLAMP WLD 200 89
16	1	438547	204 TIE TUBE WLD, 10/12R 96
17	2	438471	OUTGR SUPP ROD WLD 10-12R
18	2	438664	OUTGR TIE BAR WLD 72"2100/STS
19	2	438544	OUTGR SUPP ROD WLD 50"10/12R
20	1	438595	RH OUTGR SUPP POST WLD284C 97
21	1	438596	LH OUTGR SUPP POST WLD284C 97
22	2	438609	OUTGR SUPP BRACE, 2100 COMBO
23	2	438541	BUSH, 1.00 OD- .656 ID- .53 LG
24	2	483037	5/8 REGULAR FLAT WASHER
25	4	900271	1/2UNC X 3 1/4 HEX BOLT
26	6	900333	5/8UNC X 1 1/2 HEX BOLT
27	2	900352	5/8UNC X 2 1/4 HEX BOLT
28	16	910012	3/4UNC HEX NUT
29	6	438397	STABILIZER PIN MT WLD 90
30	1	438651	RH OUTGR SUPP MT WLD,2100CMBO
31	1	438652	LH OUTGR SUPP MT WLD,2100CMBO
32	2	438654	TOOLBAR SUPP ROD WLD,2100CMBO
33	2	438656	OUTGR TRANSPORT BAR,2100CMBO
34	2	470299	RATCHET JACK LOAD-BINDER
35	2	611016	HAIR PIN #6
36	4	900334	5/8UNC X 1 3/4 HEX BOLT
37	2	438700	TOOLBAR STOP SHIM, 16GA (.060)
38	4	438701	TOOLBAR STOP SHIM, 14GA (.075)
39	4	438702	TOOLBAR STOP SHIM, 11GA (.120)
40	2	438703	TOOLBAR STOP, 2100-ST512 COMBO
41	4	900130	3/8UNC X 1 1/4 SER FLANGE BOLT
42	4	920002	3/8 SAE FLAT WASHER
43	4	920502	3/8 LOCK WASHER
44	4	438757	8" HOIST COL ADPTR WLD, 204 04
45	2	438762	16"HOIST COL ADPTR WLD, 204 04
46	12	438293	5/8UNC X 6 1/4 CTR U-BOLT TRI
47	6	438292	TOOL BAR V-PLT WLD 8200 86

NOTE: QUANTITY LISTED IS FOR ONE MACHINE.

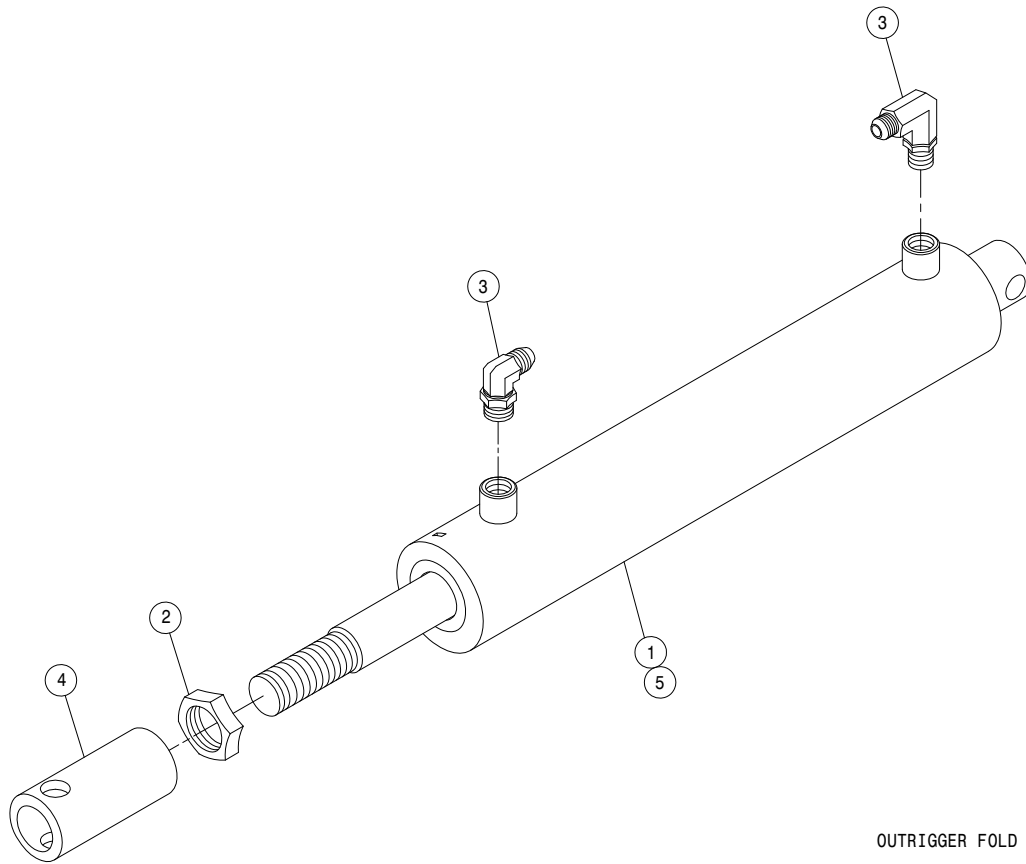

OUTRIGGER FOLD CYLINDER ASSEMBLY

DET. QTY PART NO. DESCRIPTION

1	1	621520	HYD CYL, 2.00 X 10.00 X 1.000
2	1	472322	7/8-14 UNF HEX JAM NUT
3	2	614747	.025 ELBOW ASSY,9/16MOR 90D
4	1	620653	FOLD CYL ADJ SLEEVE 97
5	1	621521	REPAIR KIT, HYD CYL 621520

NOTE: 621209 - OUTRIGGER FOLD CYLINDER ASSEMBLY WITH FITTINGS

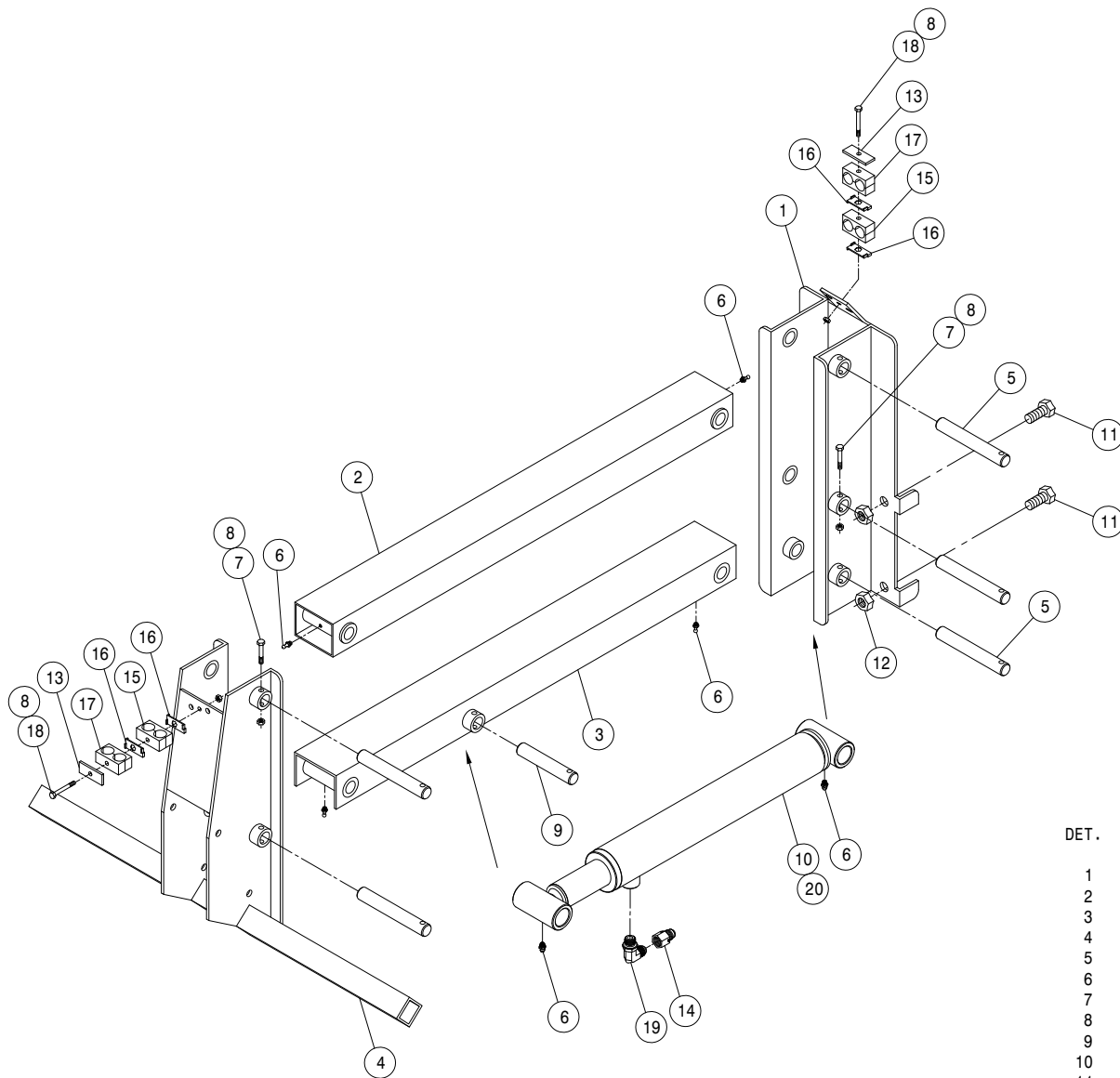

2-HEAD LIFT ASSEMBLY

DET.	QTY	PART NO.	DESCRIPTION
1	1	439136	TOOLBAR MT BRKT WLD, STSC 03
2	1	439143	UPPER LIFTARM WLD, STS COMBO 03
3	1	439146	LWR LIFTARM WLD, STS COMBO 03
4	1	439151	50" HEAD TOOLBAR WLD, STSC 03
5	5	439158	LIFT ARM PIVOT PIN, STSC 03
6	6	471005	GREASE ZERK, 1/4 28 X 1/2
7	6	900069	5/16UNC X 2" HEX BOLT
8	8	914002	5/16UNC HEX STOVER NUT
9	1	439156	LWR CYL MT PIN, STS COMBO 03
10	1	621564	HYD CYL, 2.00 X 11.00 X 1.50 1W
11	4	900401	3/4UNC X 1 1/2 HEX BOLT
12	4	914012	3/4UNC HEX STOVER NUT
13	2	470276	CLAMP COVER PLATE, SNGL, 2.55LG
14	1	618733	9/16JIC .042 ORIFICE ADPTR
15	2	470274	TUBE CLAMP BODY, .750-.750
16	4	470281	STACK BOLT SAFETY LOCK PLATE
17	2	470270	HOSE CLAMP BODY, .530-.680
18	2	900075	5/16UNC X 3 3/4 HEX BOLT
19	1	618119	9/16MJIC-90-9/16MOR LBO
20	1	621507	REPAIR KIT, HYD CYL 621506

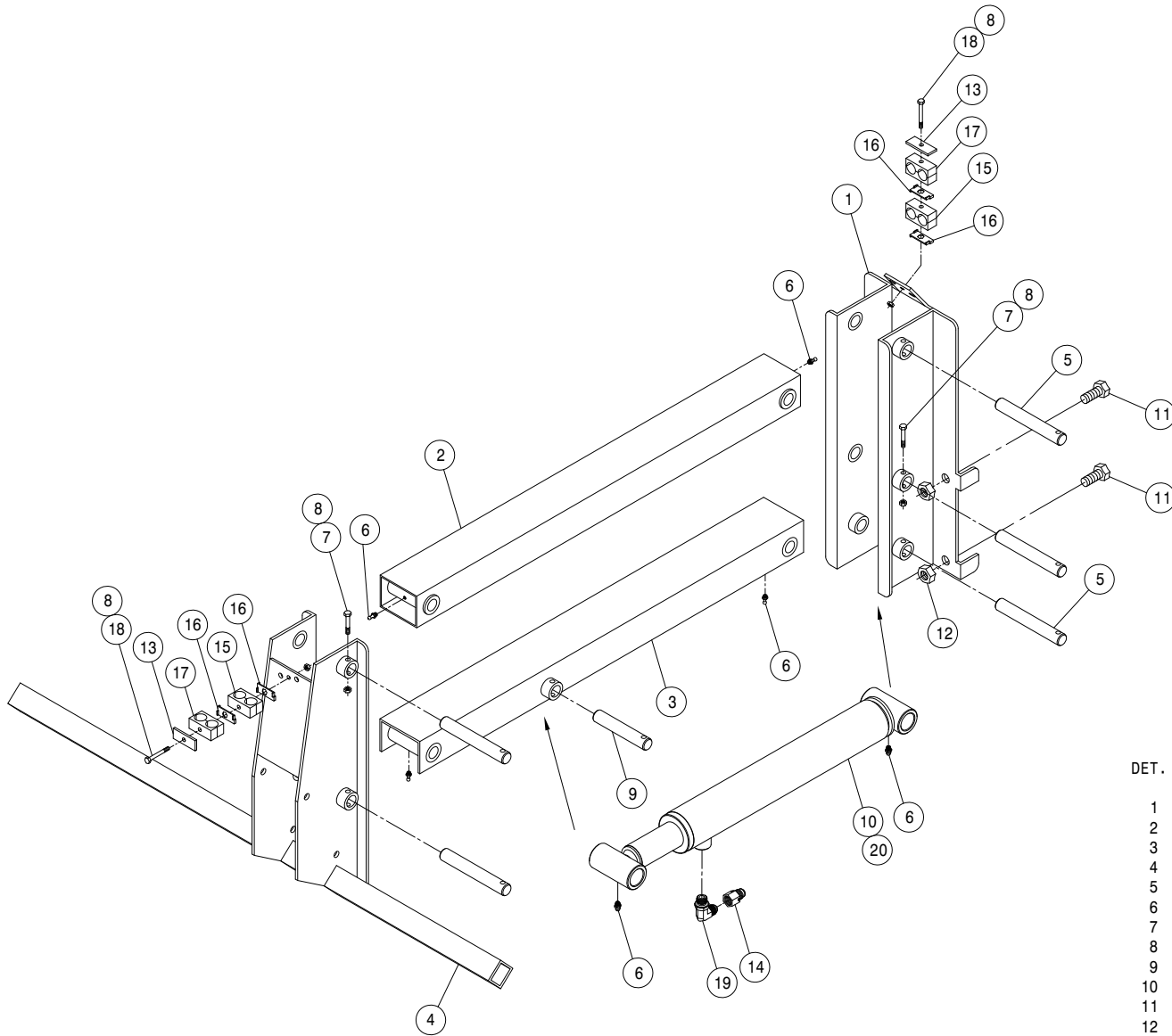

RIGHT 3-HEAD LIFT ASSEMBLY

DET.	QTY	PART NO.	DESCRIPTION	
1	1	439136	TOOLBAR MT BRKT WLD, STSC	03
2	1	439143	UPPER LIFTARM WLD, STS COMBO	03
3	1	439146	LWR LIFTARM WLD, STS COMBO	03
4	1	439163	80"RH HEAD TOOLBAR WLD, STSC	03
5	5	439158	LIFT ARM PIVOT PIN, STSC	03
6	6	471005	GREASE ZERK, 1/4 28 X 1/2	
7	6	900069	5/16UNC X 2" HEX BOLT	
8	8	914002	5/16UNC HEX STOVER NUT	
9	1	439156	LWR CYL MT PIN, STS COMBO	03
10	1	621564	HYD CYL, 2.00 X 11.00 X 1.50 1W	
11	4	900401	3/4UNC X 1 1/2 HEX BOLT	
12	4	914012	3/4UNC HEX STOVER NUT	
13	2	470276	CLAMP COVER PLATE, SNGL, 2.55LG	
14	1	618733	9/16JIC .042 ORIFICE ADPTR	
15	2	470274	TUBE CLAMP BODY, .750-.750	
16	4	470281	STACK BOLT SAFETY LOCK PLATE	
17	2	470270	HOSE CLAMP BODY, .530-.680	
18	2	900075	5/16UNC X 3 3/4 HEX BOLT	
19	1	618119	9/16MJIC-90-9/16MOR LBO	
20	1	621507	REPAIR KIT, HYD CYL 621506	

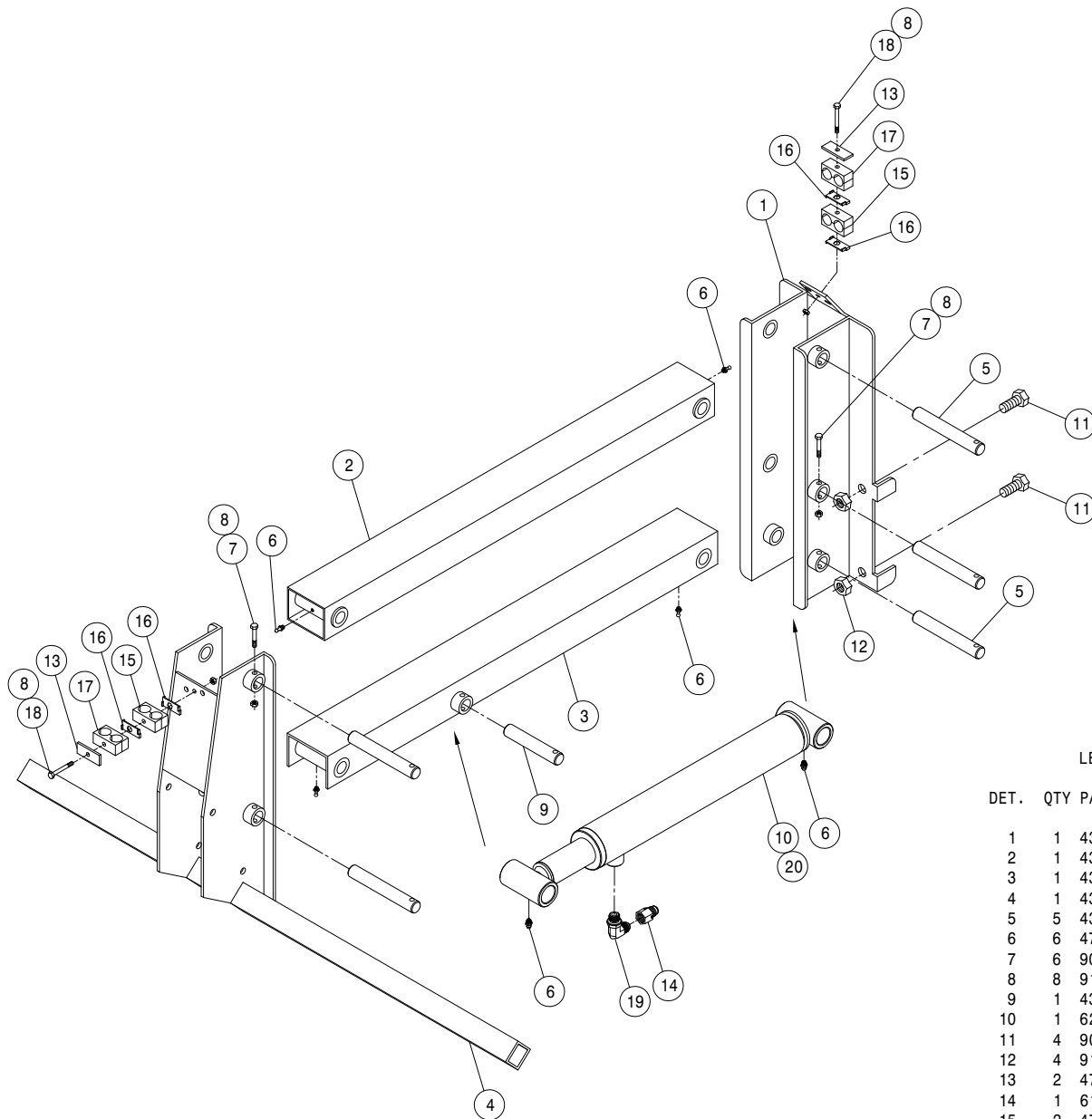

LEFT 3-HEAD LIFT ASSEMBLY

DET.	QTY	PART NO.	DESCRIPTION	
1	1	439136	TOOLBAR MT BRKT WLD, STSC	03
2	1	439143	UPPER LIFTARM WLD,STS COMBO	03
3	1	439146	LWR LIFTARM WLD, STS COMBO	03
4	1	439164	80"LH HEAD TOOLBAR WLD,STSC	03
5	5	439158	LIFT ARM PIVOT PIN, STSC	03
6	6	471005	GREASE ZERK, 1/4 28 X 1/2	
7	6	900069	5/16UNC X 2" HEX BOLT	
8	8	914002	5/16UNC HEX STOVER NUT	
9	1	439156	LWR CYL MT PIN, STS COMBO	03
10	1	621564	HYD CYL,2.00 X 11.00 X 1.50 1W	
11	4	900401	3/4UNC X 1 1/2 HEX BOLT	
12	4	914012	3/4UNC HEX STOVER NUT	
13	2	470276	CLAMP COVER PLATE,SNGL, 2.55LG	
14	1	618733	9/16JIC .042 ORIFICE ADPTR	
15	2	470274	TUBE CLAMP BODY,.750-.750	
16	4	470281	STACK BOLT SAFETY LOCK PLATE	
17	2	470270	HOSE CLAMP BODY,.530-.680	
18	2	900075	5/16UNC X 3 3/4 HEX BOLT	
19	1	618119	9/16MJIC-90-9/16MOR LBO	
20	1	621507	REPAIR KIT, HYD CYL 621506	

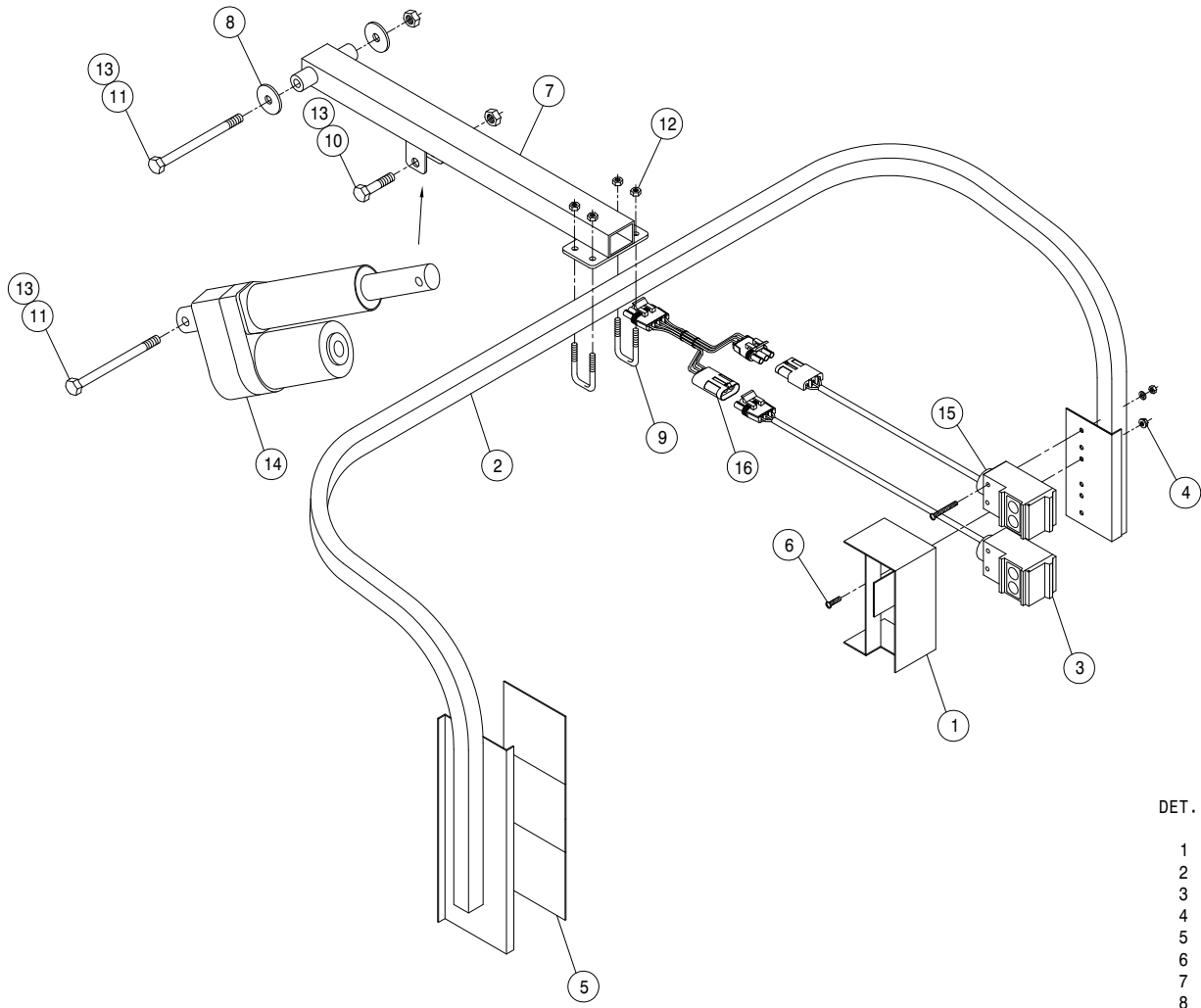

LS SENSOR ASSEMBLY

DET.	QTY	PART NO.	DESCRIPTION
	1	002841	LS 42GRU SENSOR SHIELD WLD
	1	003033	LS SENSOR MT WLD,57" STSC 03
	1	293258	LWR LS 9200 SENSOR ASSY, FEM
	2	473004	10-32 FLANGE NYLOC NUT
	3	650297	REFLECTIVE TAPE,4 X 4, RTC4-4C
	2	903883	10-32 X 1/2 PHIL PAN MACH SCR
	1	003028	LS SENSOR MT SUPP WLD, STSC 03
	2	002815	SENSOR ARM WASH, NYL
	2	473980	.31UNC-1.06ID-1.75SQ U-BOLT SS
	10	900267	1/2UNC X 2" HEX BOLT
	11	900278	1/2UNC X 6" HEX BOLT
	12	914002	5/16UNC HEX STOVER NUT
	13	914008	1/2UNC HEX STOVER NUT
	14	291634	LINEAR ACTUATOR, KODIAK K2
	15	293259	UPR LS 9200 SENSOR ASSY, MALE
	16	293188	SENSOR CONNECTOR WIRE ASSY

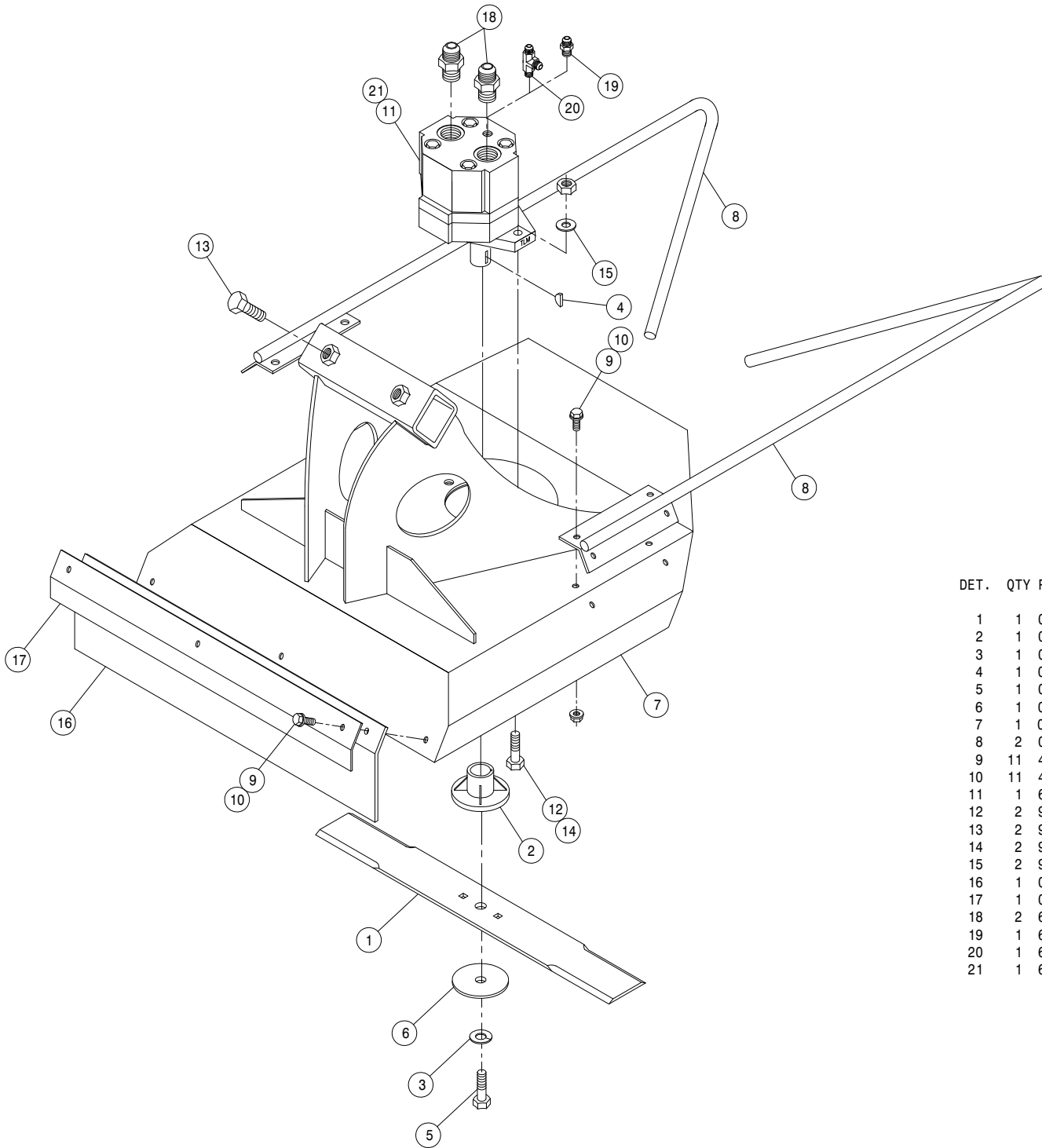

CUTTER HEAD ASSEMBLY

DET.	QTY	PART NO.	DESCRIPTION
	1	002103	CUTR BLADE 18 IN
	1	002104	CUTTER BLADE ADAPTER,RD LUG
	1	002105	3/8 LOCK WASHER ZINC PLT
	1	002106	WOODRUFF KEY # 6, .156 X .625
	1	002107	3/8UNF X 1 1/2 HEX BOLT CUTR
	1	002108	STEEL WASHER CUTTER BLADE
	1	002251	19" CUTTER DECK WLD 04
	2	002258	19" CUTR STALK GUIDE WLD 04
	11	470118	1/4UNC X 3/4 FLANGE HEX BOLT
	11	470121	1/4UNC HEX FLANGE LOCK NUT
	1	610755	BARNES HYD MOTOR, D-SERIES 01
	2	900130	3/8UNC X 1 1/4 SER FLANGE BOLT
	2	900265	1/2UNC X 1 1/2 HEX BOLT
	2	914004	3/8UNC HEX STOVER NUT
	2	920002	3/8 SAE FLAT WASHER
	1	002256	19" REAR CUTR DECK EXT FLAP 04
	1	002257	19" REAR CUTR DECK FLAP KPR 04
	2	611125	3/4MJIC-3/4MOR ADPTR
	1	618530	9/16MJIC-1/8MNPT ADPTR
	1	618546	1/8MNPT RUN TEE-9/16MJIC
	1	610756	SEAL, OUTER FOR 610755

TWO HEAD ASSEMBLY

THREE HEAD ASSEMBLY

LEFT SIDE OF OPERATOR

RIGHT SIDE OF OPERATOR

LEFT SIDE OF OPERATOR

RIGHT SIDE OF OPERATOR

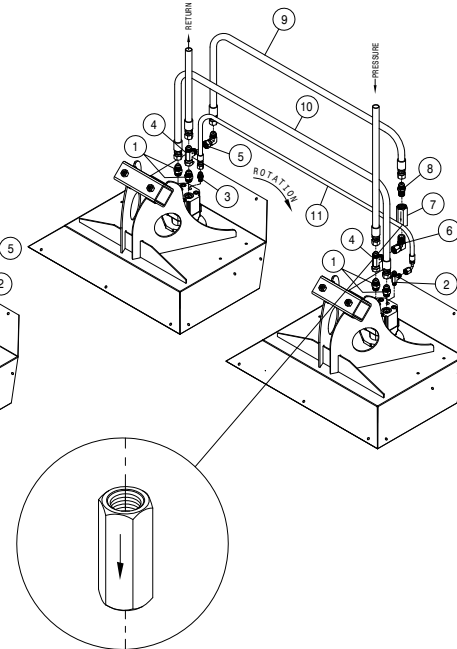
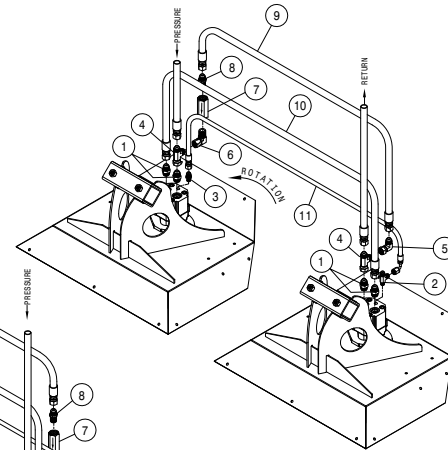
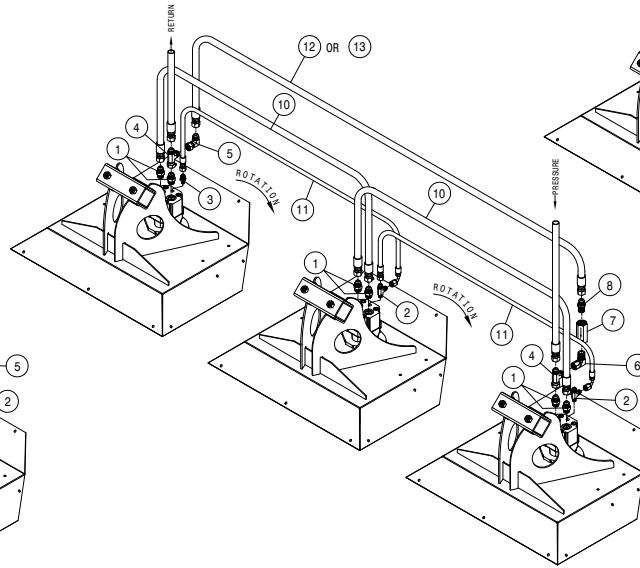
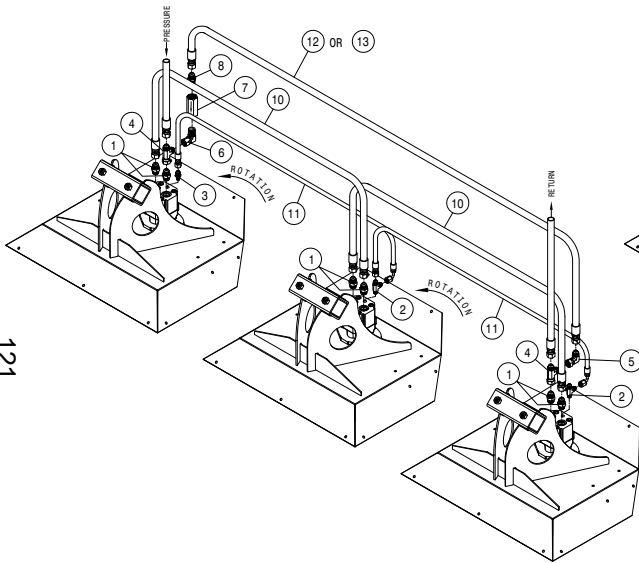

121

HYD SCHEM, CUTTER CHECK VLV 204 07

DET. QTY PART NO. DESCRIPTION

1	611125	3/4MJIC-3/4MOR ADPTR	
2	618546	1/8MNPT RUN TEE-9/16MJIC	
3	618530	9/16MJIC-1/8MNPT ADPTR	
4	618451	3/4FJIC SW RUN TEE-3/4MJIC	
5	618609	3/4MJIC-90-3/4FJIC SWIV LBO	
6	618620	3/4FJX-90-1/2MNPT ADPTR	
7	690338	LINE CHECK VALVE HYD .50NPT	
8	611147	3/4MJIC-1/2MNPT ADPTR	
9	616025	08C1T-08FJX-08FJX-50	H/A
10	614368	08C1T-08FJX-08FJX-60	H/A
11	616422	04C1T-06FJX-06FJX90-50	H/A
12	616031	08C1T-08FJX-08FJX-83	H/A
13	614662	08C1T-08FJX-08FJX-72	H/A

DET REQ	DESCRIPTION
HAGIE HAGIE MANUFACTURING COMPANY CLARION, IOWA 50525	
REMOVE ALL SHARP CORNERS & BURRS	
TOLERANCE UNLESS OTHERWISE SPECIFIED	
FRACTION ±1/32	DECIMALS X.XX ±.03 X.XXX ±.005
ANGLES ±1°	
DESCRIPTION HYD SCHEM, CUTTER CHECK VLV 204 07	
DRAWN BY T. MARKER	SCALE FULL
CHECKED BY	APPROVED BY
DATE 05-16-07	DRAWING NUMBER 498929
SHEET OF	

568121

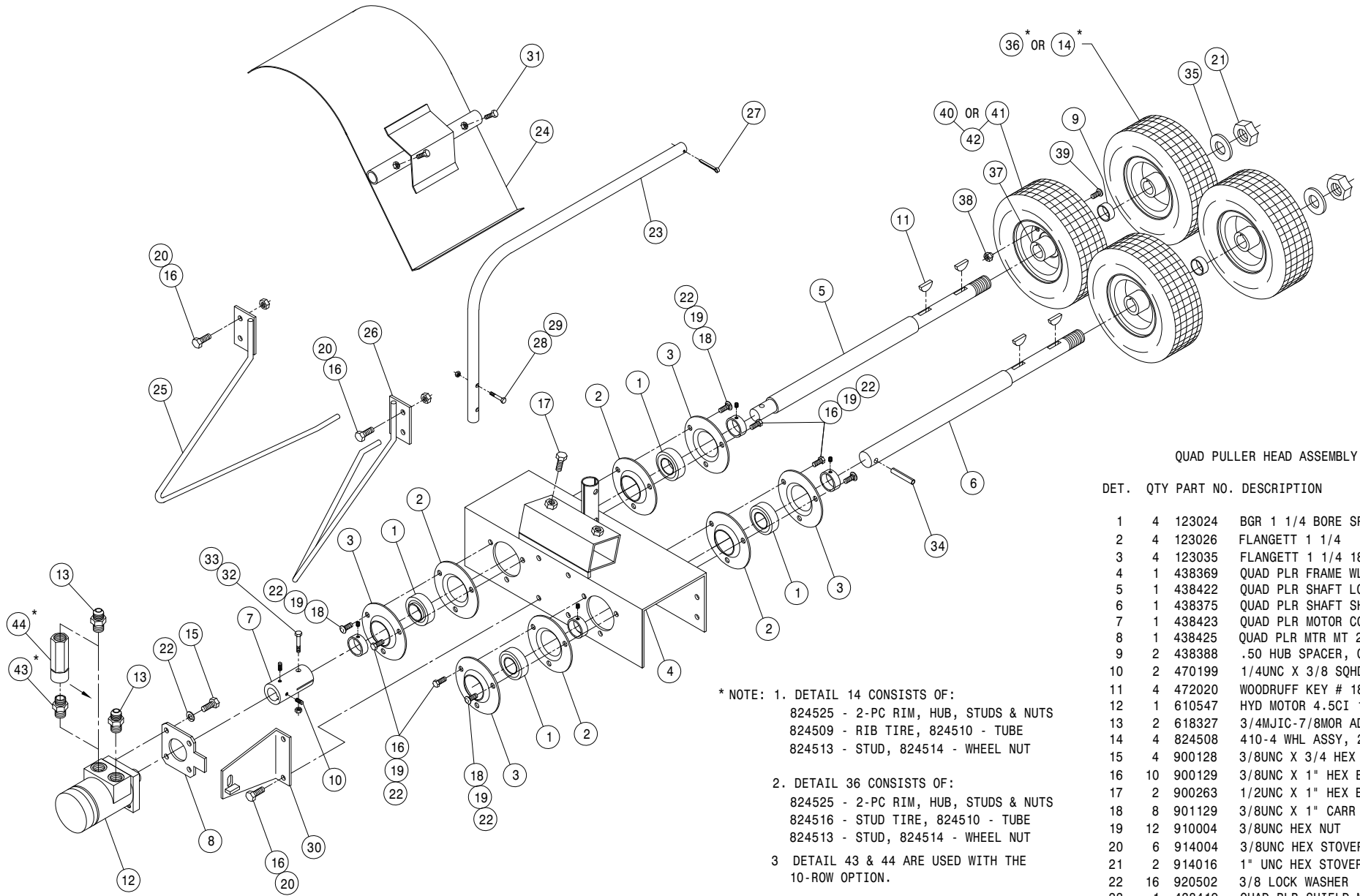

QUAD PULLER HEAD ASSEMBLY

DET.	QTY	PART NO.	DESCRIPTION
1	4	123024	BGR 1 1/4 BORE SPHERICL RELUB
2	4	123026	FLANGETT 1 1/4
3	4	123035	FLANGETT 1 1/4 180 DEG ZERK
4	1	438369	QUAD PLR FRAME WLD 200 90
5	1	438422	QUAD PLR SHAFT LONG 200 91
6	1	438375	QUAD PLR SHAFT SHORT 200 90
7	1	438423	QUAD PLR MOTOR COUPLER 200 91
8	1	438425	QUAD PLR MTR MT 200 91
9	2	438388	.50 HUB SPACER, QUAD PLR
10	2	470199	1/4UNC X 3/8 SQHD CUP SET SCR
11	4	472020	WOODRUFF KEY # 18 1/4 X 1 1/8
12	1	610547	HYD MOTOR 4.5CI 1IN SHFT
13	2	618327	3/4MJIC-7/8MOR ADPTR
14	4	824508	410-4 WHL ASSY, 2P STUD
15	4	900128	3/8UNC X 3/4 HEX BOLT
16	10	900129	3/8UNC X 1" HEX BOLT
17	2	900263	1/2UNC X 1" HEX BOLT
18	8	901129	3/8UNC X 1" CARR BOLT
19	12	910004	3/8UNC HEX NUT
20	6	914004	3/8UNC HEX STOVER NUT
21	2	914016	1" UNC HEX STOVER NUT
22	16	920502	3/8 LOCK WASHER
23	1	438419	QUAD PLR SHIELD MT TUBE 91
24	1	438415	QUAD PLR SHIELD WLD 200 91
25	1	438381	RH QUAD PLR STALK GUIDE WLD90
26	1	438384	LH QUAD PLR STALK GUIDE WLD90
27	1	390984	COTTER PIN 1/8 X 1 1/4
28	2	900004	1/4UNC X 1 1/4 HEX BOLT
29	2	914000	1/4UNC HEX STOVER NUT
30	1	438424	QUAD PLR MTR MT PLT WLD
31	2	900064	5/16UNC X 3/4 HEX BOLT
32	1	900830	5/16UNC X 2" HEX BOLT GR8
33	1	914002	5/16UNC HEX STOVER NUT
34	1	473805	ROLL PIN, 1/4 X 1 1/2
35	2	483032	1 1/2 X 1" X .134TH MACH WASH
36	4	824515	410-4 WHL ASSY, 2P SAWTOOTH
37	4	824525	4 X 2.25 WHEEL & HUB
38	16	824514	WHL NUT, 4-BOLT HUB
39	16	824513	STUD, 4-BOLT HUB
40	4	824509	4.10/3.50-4 2PLY STUD TIRE
41	4	824516	4.10/3.50 2P SAWTOOTH TIRE
42	4	824510	4.10/3.50-4 BENT STEM TUBE
43	1	618586	7/8MOR UNION
44	1	607522	FLOW REGULATOR, 8GPM VONBERG

* NOTE: 1. DETAIL 14 CONSISTS OF:
 824525 - 2-PC RIM, HUB, STUDS & NUTS
 824509 - RIB TIRE, 824510 - TUBE
 824513 - STUD, 824514 - WHEEL NUT

2. DETAIL 36 CONSISTS OF:
 824525 - 2-PC RIM, HUB, STUDS & NUTS
 824516 - STUD TIRE, 824510 - TUBE
 824513 - STUD, 824514 - WHEEL NUT

3. DETAIL 43 & 44 ARE USED WITH THE 10-ROW OPTION.

DET.	QTY	PART NO.	DESCRIPTION
36	4	824515	410-4 WHL ASSY, 2P SAWTOOTH
37	4	824525	4 X 2.25 WHEEL & HUB
38	16	824514	WHL NUT, 4-BOLT HUB
39	16	824513	STUD, 4-BOLT HUB
40	4	824509	4.10/3.50-4 2PLY STUD TIRE
41	4	824516	4.10/3.50 2P SAWTOOTH TIRE
42	4	824510	4.10/3.50-4 BENT STEM TUBE
43	1	618586	7/8MOR UNION
44	1	607522	FLOW REGULATOR, 8GPM VONBERG

This Page Intentionally Blank

NOTICE

The following page contains decals for the DTS10 Combo.

These decals can be obtained from Hagie Mfg. Co. and should be used whenever your machine is repainted or when the decals become worn, weathered, or faded.

Special attention should be paid to decals involving personal safety. They have been attached for your protection.

KEEP THEM IN PLACE.

Contact: Hagie Manufacturing Co.
721 Central Ave West
Box 273
Clarion, Iowa 50525-0273

DTS 10 COMBO DECALS

QTY.	PART NO.	DESCRIPTION	LOCATION
1	650108	MAIN SPRAY POWER DECAL	ON SWITCH PANEL HOUSING
1	650109	LOW HYDRAULIC OIL DECAL	ON SWITCH PANEL HOUSING
1	650154	PATENTS,HAGIE UPPRONT DECAL	ON LOWER LEFT REAR OF MAINFRAME
1	650175	EMERGENCY EXIT DECAL	ON THE LOWER LEFT ON REAR WINDOW
1	650176	CAUTION, CAB CHEM EXPOSOR DECAL	ON THE LOWER LEFT FRONT WINDSHIELD
1	650270	CANTRAK DECAL	ON CANTRAK
1	650273	MASTER SWITCH DECAL	ON MOTOR CONTROL VALVE SWITCH BOX
1	650274	QUICK CONNECT DECAL	ON FRONT RETURN HOSE BRACKET
1	650303	CUTTER ROTATION DECAL	ON THE LOWER LEFT OF FRONT WINDOW
1	650336	FOLD BOOM WARNING DECAL	ON RH SIDE WINDOW
1	650337	ELECTROCUITION HAZARD DECAL	ON RH SIDE WINDOW
1	650338	DEPTH CMD 6-LIFT DECAL	ON DEPTH COMMAND BOX
1	650339	HYDRAULIC OIL IND. DECAL	ON STEERING POST
1	650340	PARK BRAKE DECAL	NEAR PARK SWITCH
1	650343	HYDROSTATIC CONTROL DECAL	ON CONSOLE
1	650345	BOOM CONTROL PANEL DECAL	ON SWITCH PANEL COVER
1	650347	NOTICE-R134A CHARGE DECAL	ON ENGINE NEAR A/C COMPRESSOR
1	650348	NOTICE-DRAIN AIR TANK DECAL	ON AIR TANK
1	650349	LIGHT SWITCH PANEL DECAL	ON SWITCH PANEL IN HEADLINER
1	650350	CAUTION, BOOSTER TERMINAL DECAL	ON LOWER BACK SHEET METAL
1	650351	AGITATION VFC DECAL	ON LOWER BACK SHEET METAL
2	650352	RH TREAD ADJ INDICATOR DECAL	1-ON RH FRONT INDICATOR MOUNT 1-ON LH REAR INDICATOR MOUNT
2	650353	LH TREAD ADJ INDICATOR DECAL	1-ON LH FRONT INDICATOR MOUNT 1-ON RH REAR INDICATOR MOUNT
1	650357	LS DEPTH CTRL DECAL	ON RECEPTACLE MOUNT
1	650367	AIR FILTER INSTRUCTION DECAL	ON ENGINE AIR FILTER END CAP
1	650369	FUSE BOX DECAL	ON FUSE BOX COVER
1	650370	SWITCH PANEL DECAL	ON SWITCH PANEL COVER
1	650371	TREAD ADJUST DECAL	ON CONSOLE
1	650372	MAIN ELECTRIC DISCONNECT DECAL	NEAR DISCONNECT SWITCH
1	650819	DANGER, CUTTING BLADES DRCAL	2-ON EACH CUTTER HEAD
1	650820	CAUTION, MOVING PARTS DECAL	1-ON EACH QUAD HEAD
1	650822	SOLUTION PUMP DECAL	ON FRONT MAINFRAME SHIELD
1	650831	EMERGENCY STOP DECAL	ON STEERING POST
1	650847	NO PASSENGER DECAL	ON LH REAR ON CAB
2	650848	SLIP OR FALL DECAL	ON BACK OF FUEL TANKS
2	650849	ENGINE FUEL DECAL	NEAR EACH FUEL TANK NECK
2	650850	CHEMICAL DECAL	ON TANK BAND TIE
2	650851	SHIELDS DECAL	ON LOWER REAR OF MAINFRAME
1	650852	READ MANUAL DECAL	ON LEFT CONSOLE TOP
1	650931	1 3/4 X 4 HAGIE DECAL	1-ON EACH QUAD HEAD
1	650954	DIESEL DECAL	NEAR EACH FUEL NECK
1	650955	SLOW ENGINE TO IDLE DECAL	ON THE LOWER LEFT OF FRONT WINDOW
1	650981	COOLING SYSTEM DECAL	NEAR RADIATOR CAP
1	650982	ELECTRICAL DECAL	ON ENGINE HOOD ABOVE BATTERY
4	650985	WHEEL BOLT TORQUE DECAL	ON EACH WHEEL RIM
1	KDC400	DTS 10 DECAL KIT	ON ENGINE HOOD, SOLUTION TANK
1	650214	DECAL SET,DTS10 RH TANK MOLDIN	ON RIGHT SIDE OF SOLUTION TANK
1	650215	DECAL SET,DTS10 LH TANK MOLDIN	ON LEFT SIDE OF SOLUTION TANK

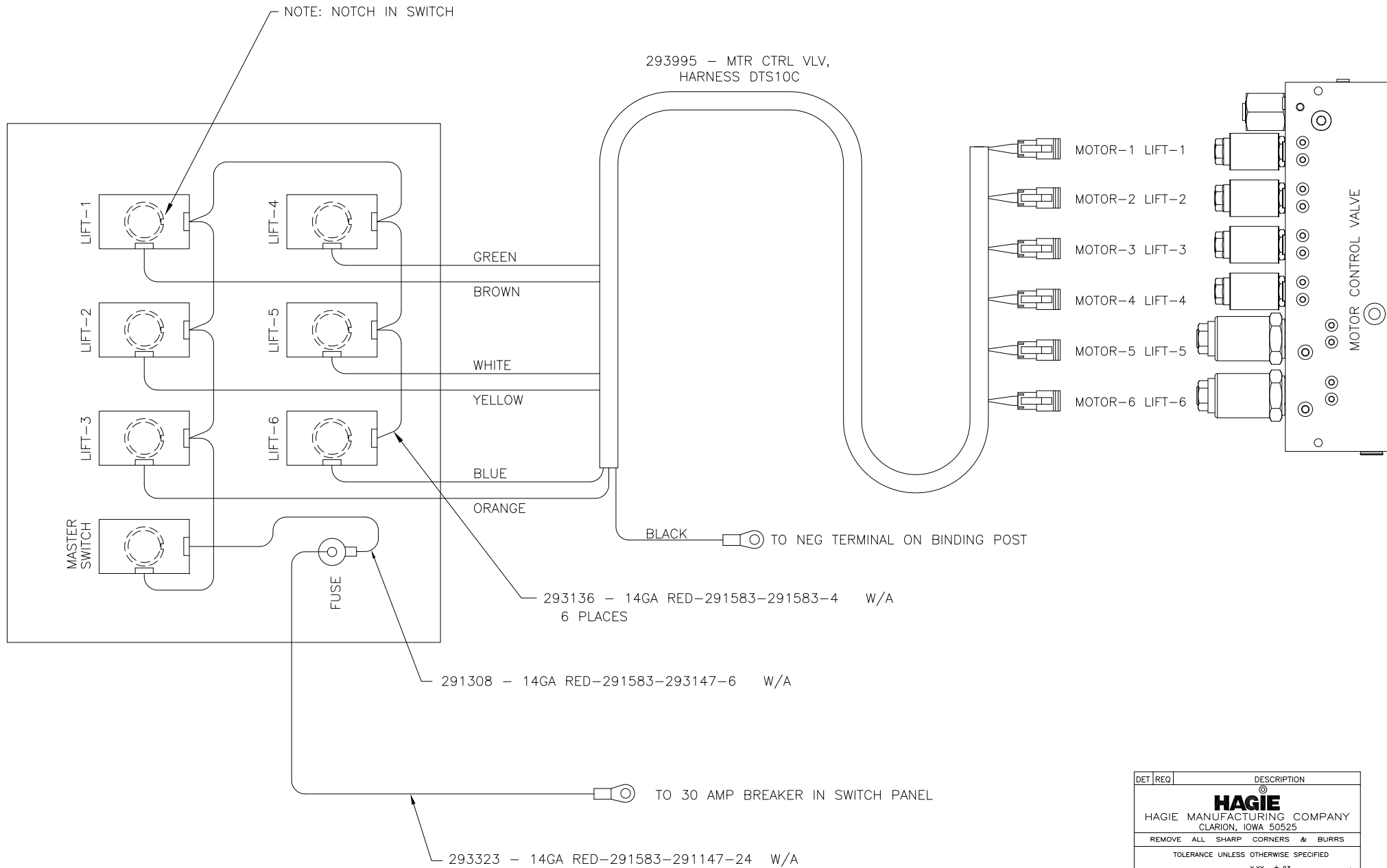

DET	REQ	DESCRIPTION
		 HAGIE HAGIE MANUFACTURING COMPANY CLARION, IOWA 50525
REMOVE ALL SHARP CORNERS & BURRS		
TOLERANCE UNLESS OTHERWISE SPECIFIED		
FRACTION ±1/32	DECIMALS X.XX ±.03 X.XXX ±.005	ANGLES ±1°
DESCRIPTION		
MTR CTRL VLV SW ASSY,DTS10C*10		
DRAWN BY	T. MARKER	SCALE NONE
CHECKED BY		APPROVED BY
DATE	DRAWING NUMBER	
03-23-10	003207	
SHEET 2 OF 2		

NOTE: NOTCH IN SWITCH

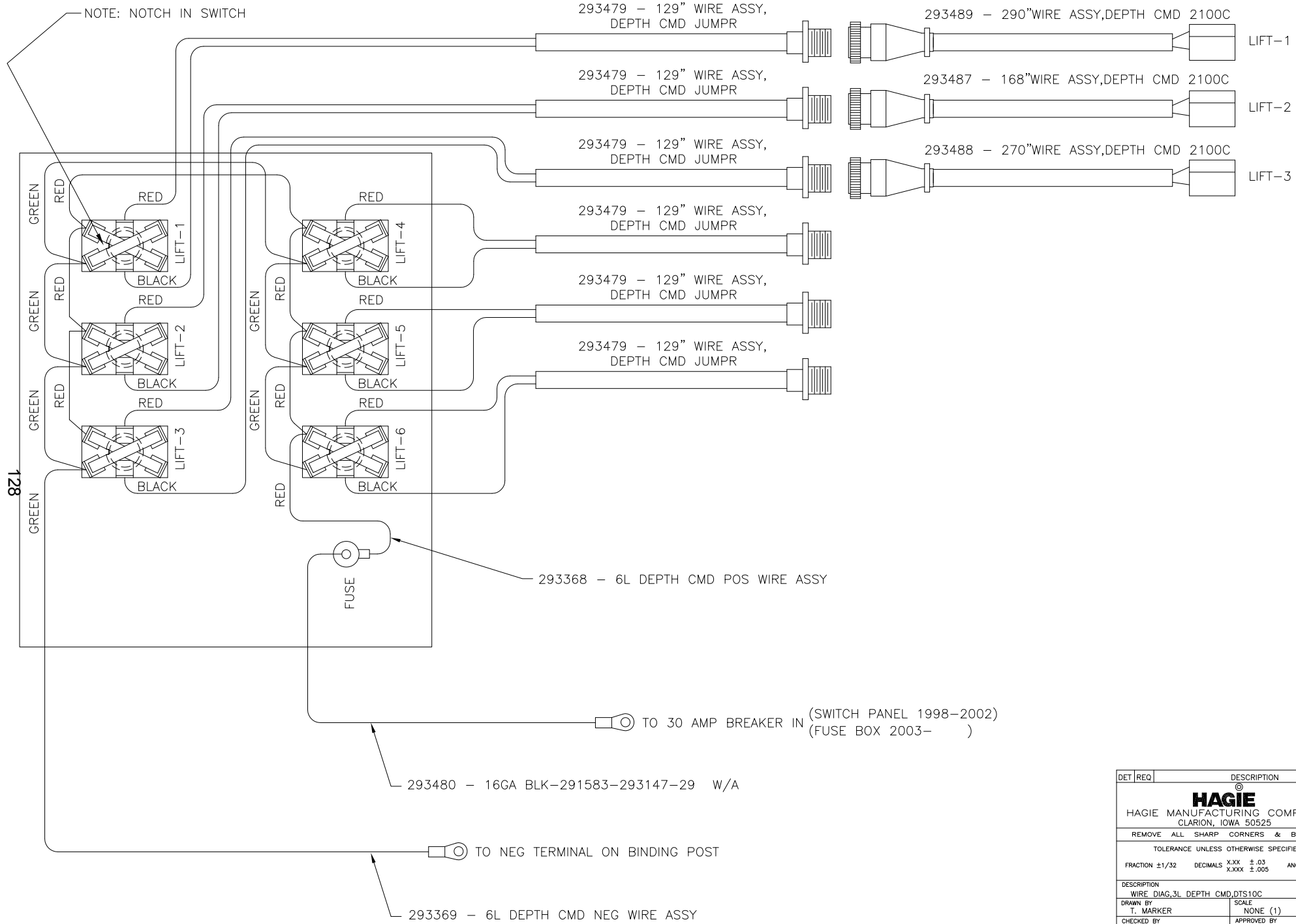

DET	REQ	DESCRIPTION
		HAGIE HAGIE MANUFACTURING COMPANY CLARION, IOWA 50525
REMOVE ALL SHARP CORNERS & BURRS		
TOLERANCE UNLESS OTHERWISE SPECIFIED		
FRACTION ±1/32		DECIMALS X.XX ±.03 X.XXX ±.005
ANGLES ±1°		
DESCRIPTION WIRE DIAG, 3L DEPTH CMD, DTS10C		
DRAWN BY T. MARKER	CHECKED BY	SCALE NONE (1) APPROVED BY
DATE 12-29-98	DRAWING NUMBER 498572	
SHEET	OF	

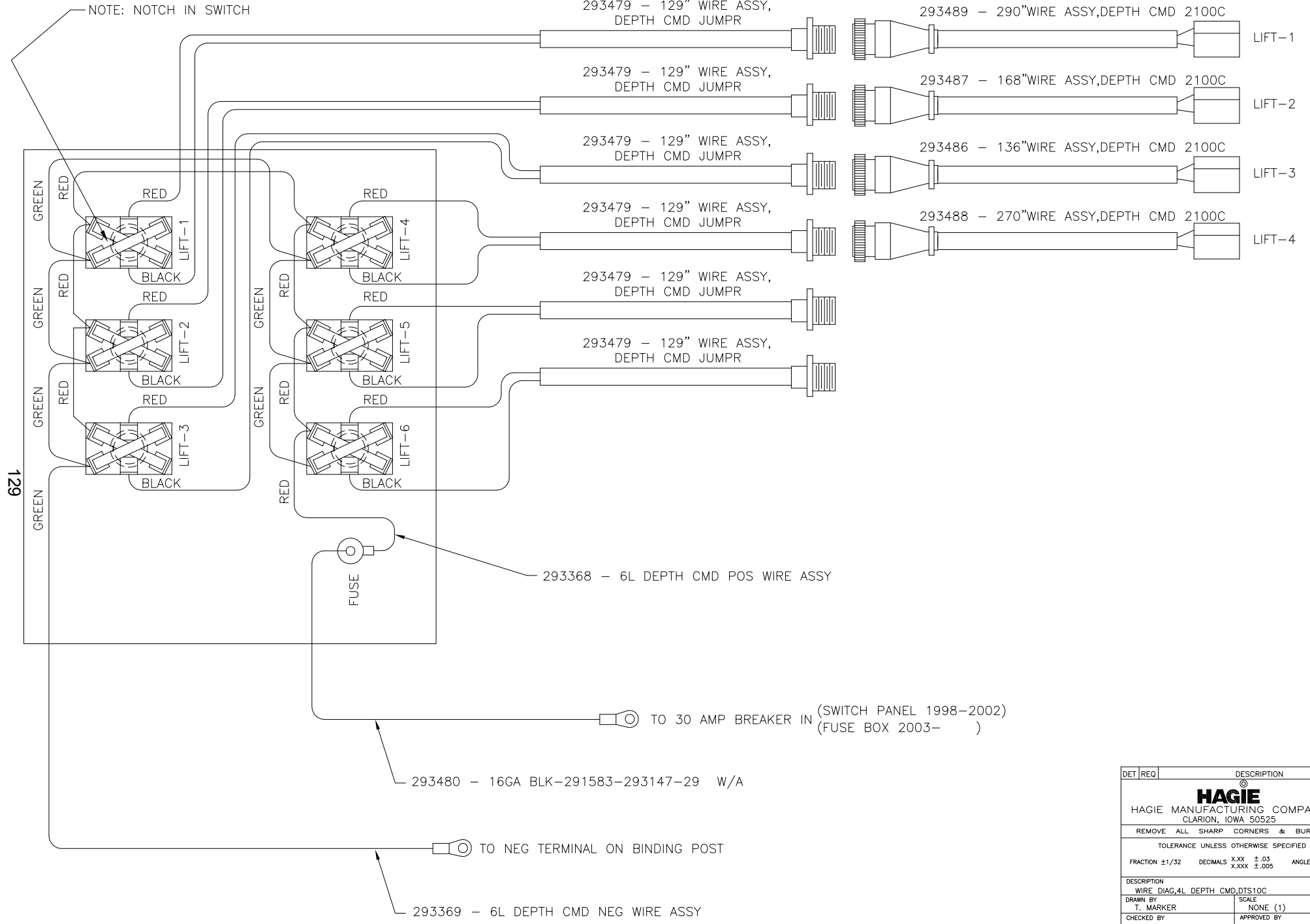

DET	REQ	DESCRIPTION
		HAGIE
		HAGIE MANUFACTURING COMPANY CLARION, IOWA 50525
		REMOVE ALL SHARP CORNERS & BURRS
		TOLERANCE UNLESS OTHERWISE SPECIFIED
		FRACTION ±1/32 DECIMALS X.XX ±.03 X.XXX ±.005 ANGLES ±1°
		DESCRIPTION WIRE DIAG, 4L DEPTH CMD, DTS10C
		DRAWN BY T. MARKER SCALE NONE (1)
		CHECKED BY APPROVED BY
		DATE 12-29-98 DRAWING NUMBER 498573
		SHEET OF

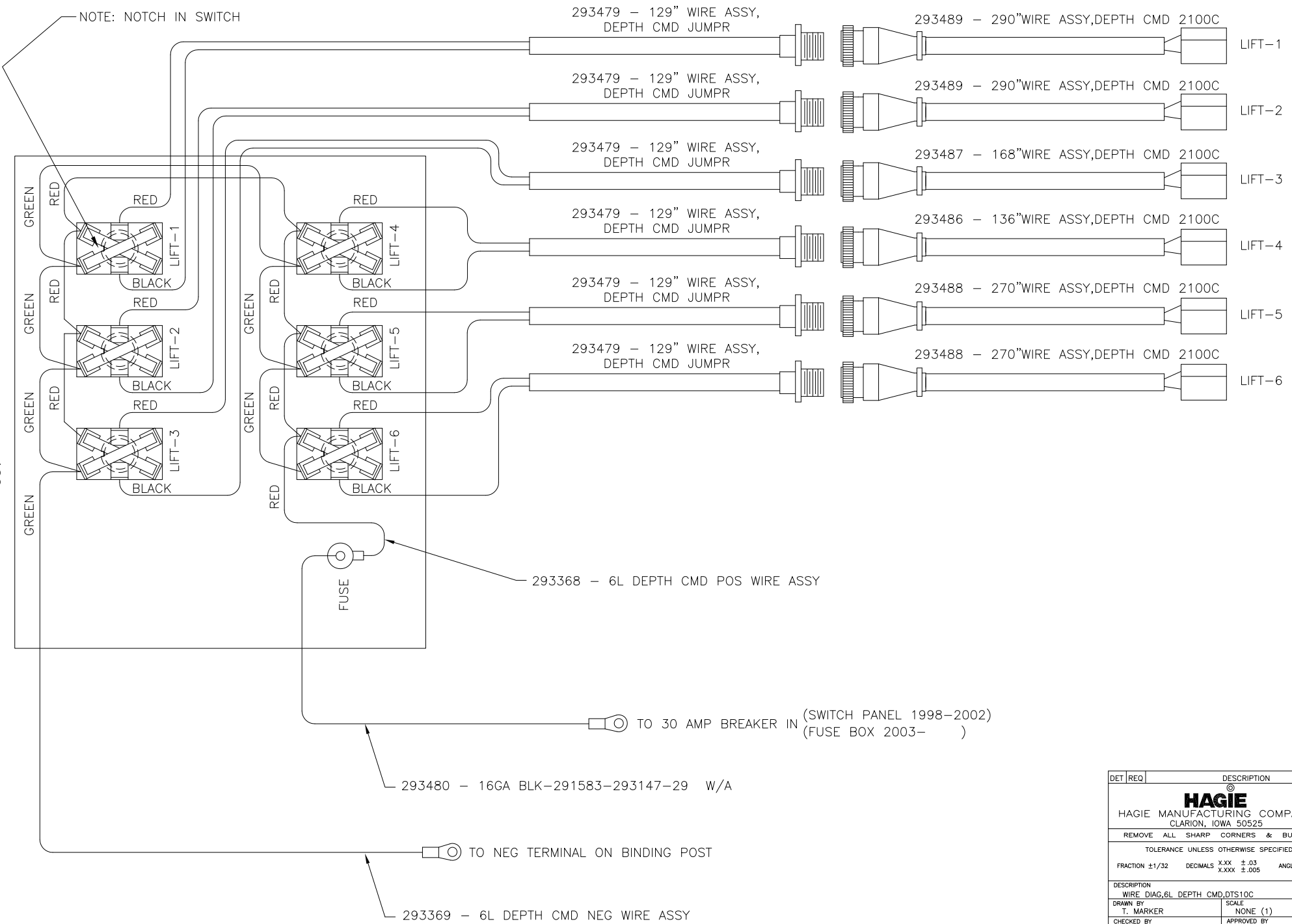

DET	REQ	DESCRIPTION
HAGIE		
HAGIE MANUFACTURING COMPANY CLARION, IOWA 50525		
REMOVE ALL SHARP CORNERS & BURRS		
TOLERANCE UNLESS OTHERWISE SPECIFIED		
FRACTION ±1/32	DECIMALS X.XX ±.03 X.XXX ±.005	ANGLES ±1°
DESCRIPTION WIRE DIAG, 6L DEPTH CMD, DTS10C		
DRAWN BY T. MARKER	SCALE NONE (1)	
CHECKED BY	APPROVED BY	
DATE 12-29-98	DRAWING NUMBER 498574	
SHEET	OF	

This Page Intentionally Blank

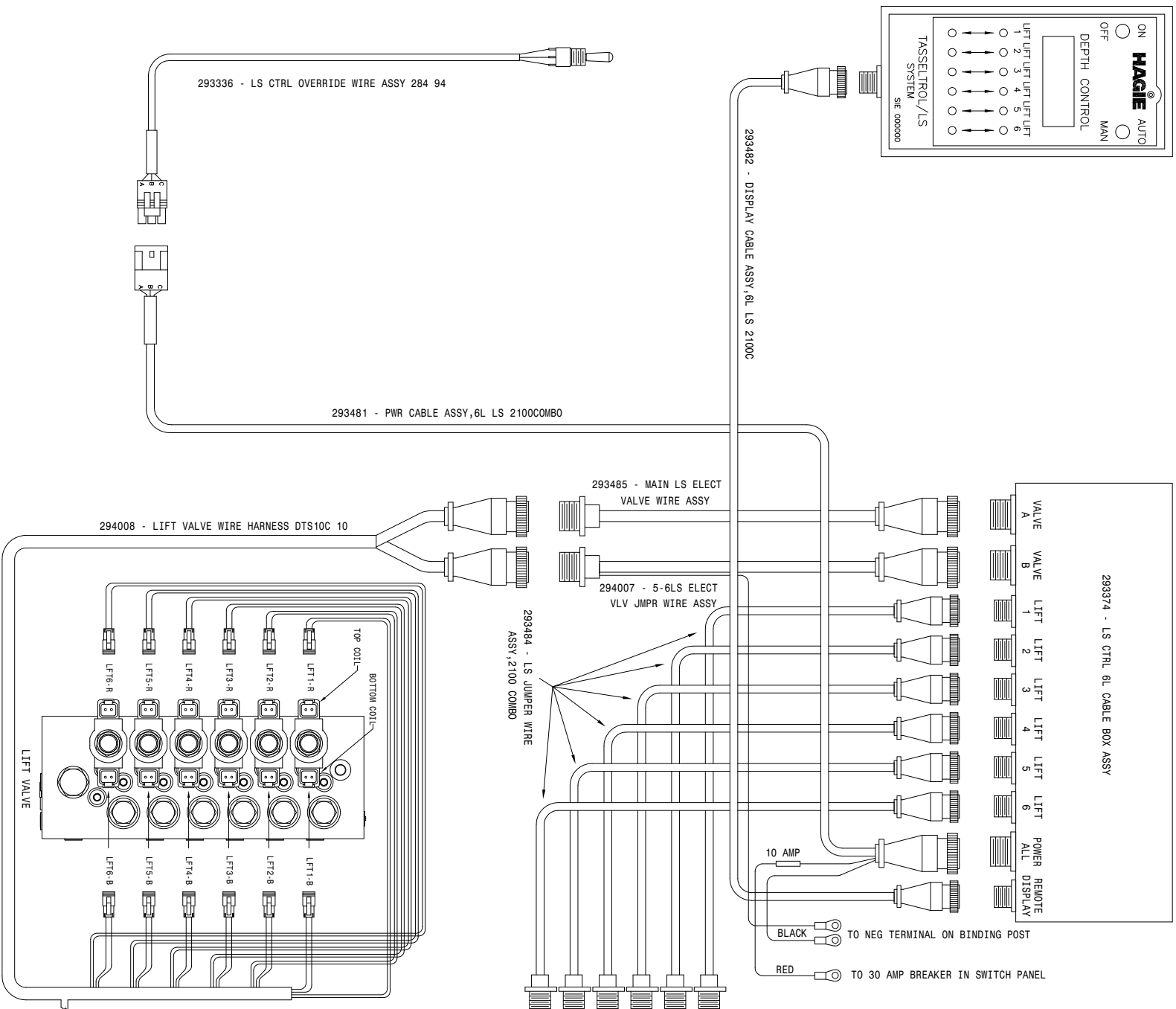

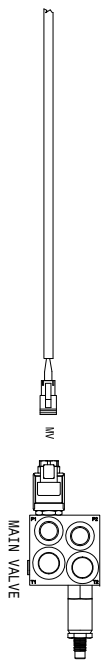
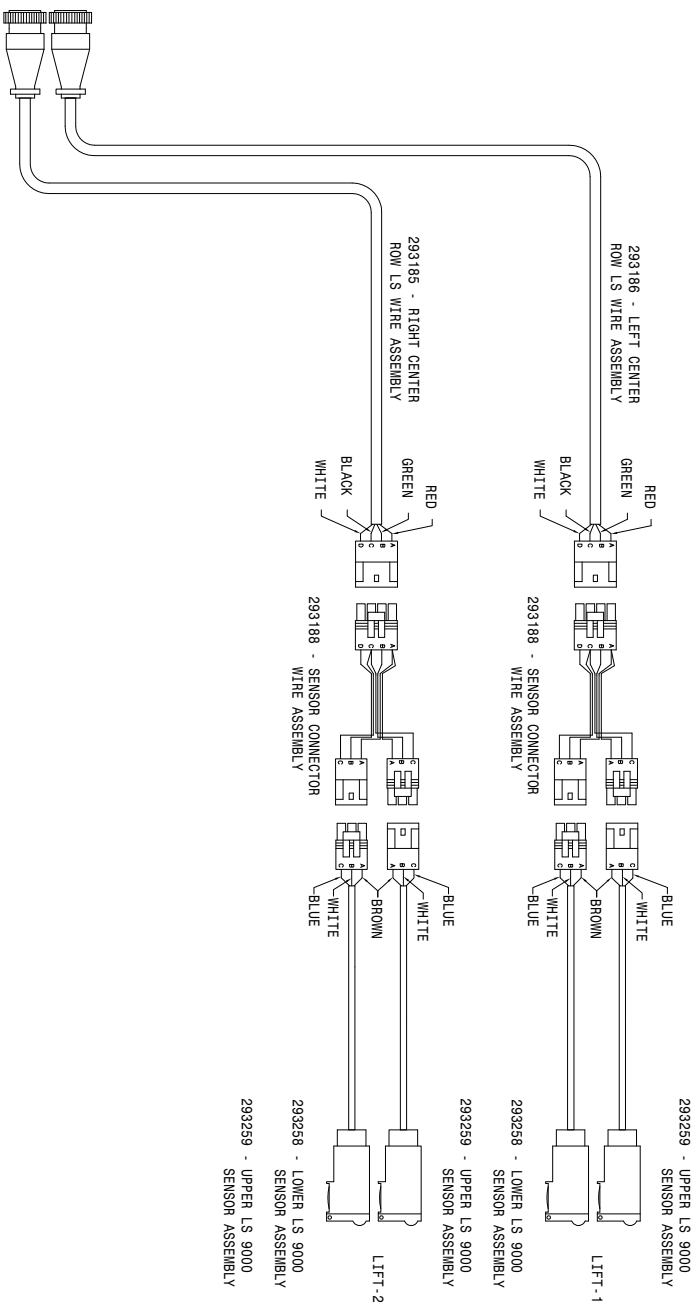

DET/REV	DESCRIPTION
	HAGIE HAGIE MANUFACTURING COMPANY CLARION, IOWA 50525
	REMOVE ALL SHARP CORNERS & BURRS
	TOLERANCE UNLESS OTHERWISE SPECIFIED
	FRACTION 1/12 DECIMALS XXX ±.03 ANGLES ±1°
DESCRIPTION	
	LS 975 2-LIFT WIRE DIAG/DTS/OC 10
DESIGNED BY	SCALE
DRAWN BY	DATE
CHECKED BY	APPROVED BY
DATE 10-12-10	DRAWING NUMBER
SHEET 08	499197

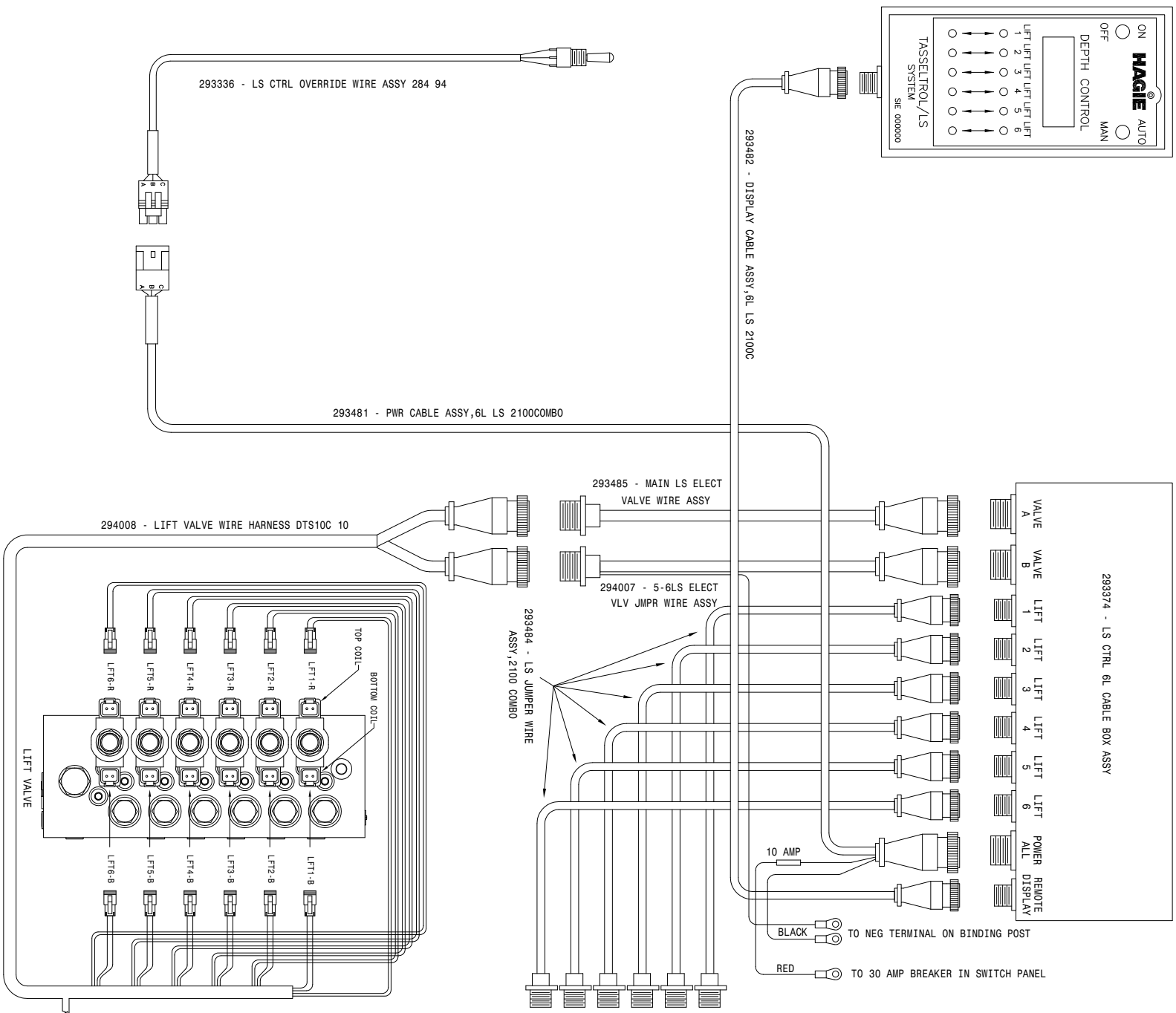

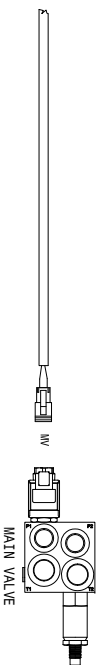
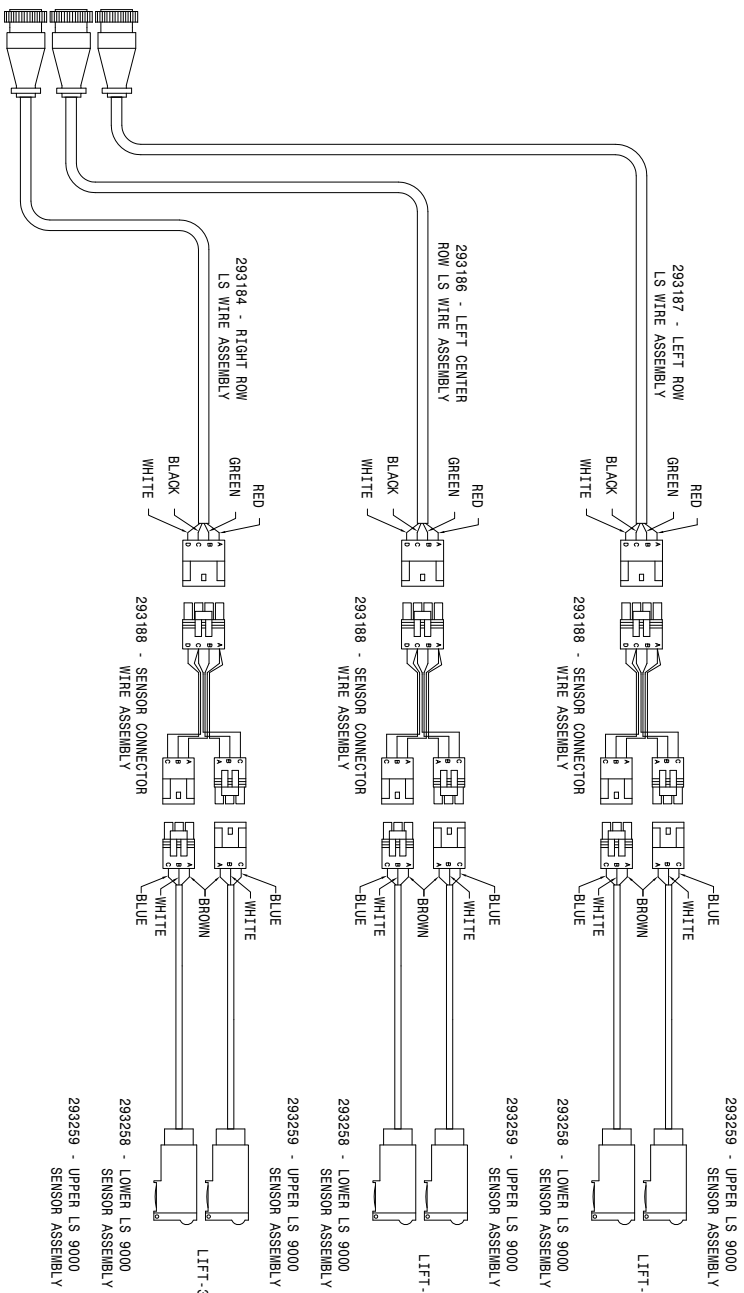

DET	REQ	DESCRIPTION
		HAGIE
		HAGIE MANUFACTURING COMPANY
		CLAYTON, IOWA 50525
		REMOVE ALL SHARP CORNERS & BURRS
		TOLERANCE UNLESS OTHERWISE SPECIFIED
		FRACTION 1/32 DECIMALS XXX ± .005 ANGLES ± °
		DESCRIPTION
		LS SYS 3-LIFT WIRE DIAG/DTS/DOC 10
		DRAWN BY
		SCALE
		CHECKED BY
		APPROVED BY
		DATE
		10-12-10
		DRAWING NUMBER
		499198
		SHEET
		OF

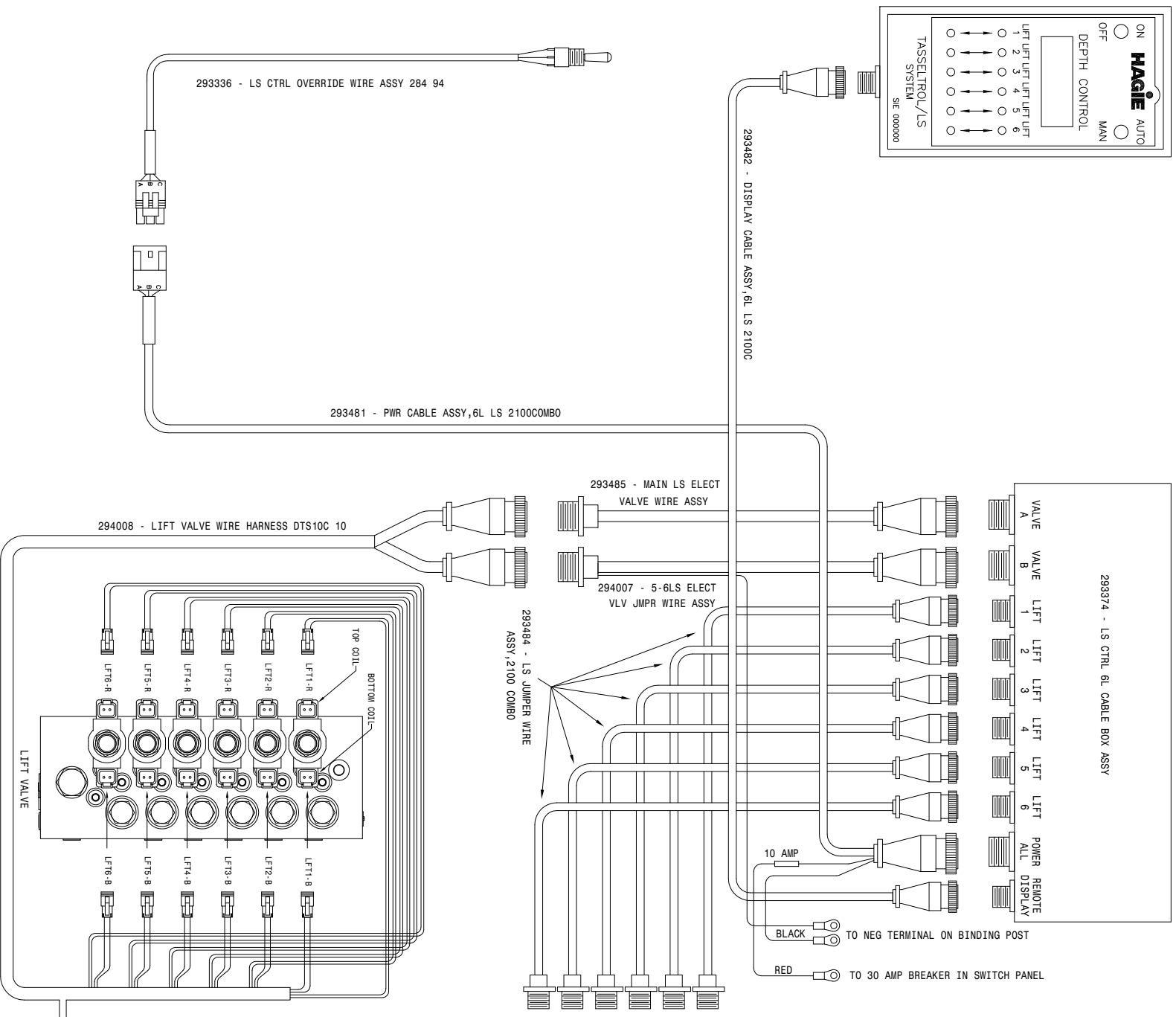

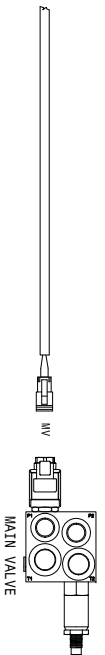
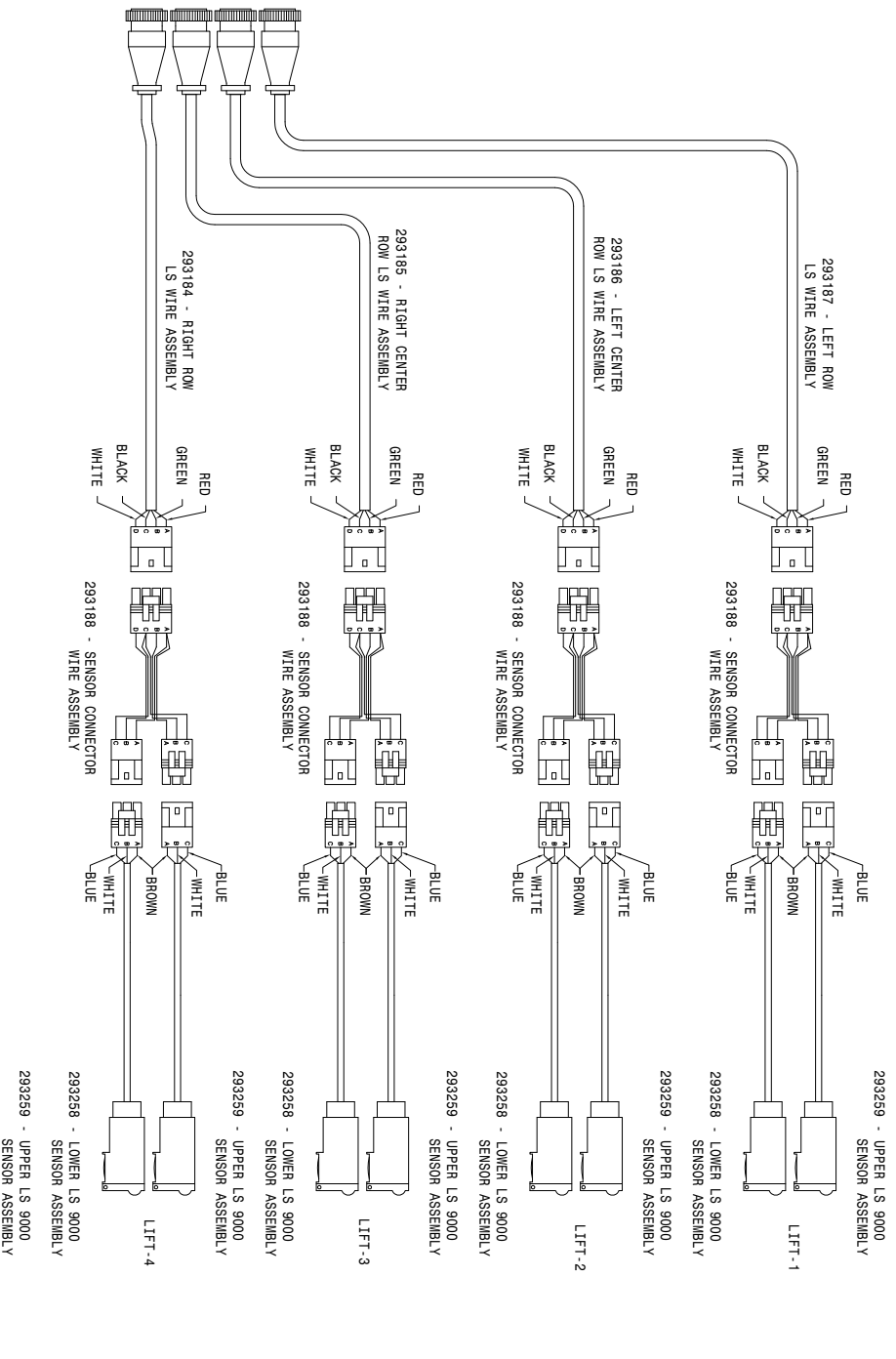

DET/REV	DESCRIPTION
	HAGIE
	HAGIE MANUFACTURING COMPANY
	CLAYTON, IOWA, 50525
	REMOVE ALL SHARP CORNERS & BURRS
	TOLERANCE UNLESS OTHERWISE SPECIFIED
	FINISH 2/1/32 DECIMALS XXX ±.03 ANGLES 2°
	FINISH XXXX ±.005
	DESCRIPTION
	LS STR 4-LIFT WIRE DIAGNOSTICS 10
	DATE 10-12-10
	DRAWN BY H.A.F
	CHECKED BY APPROVED BY
	SHEET 5 th
	499199

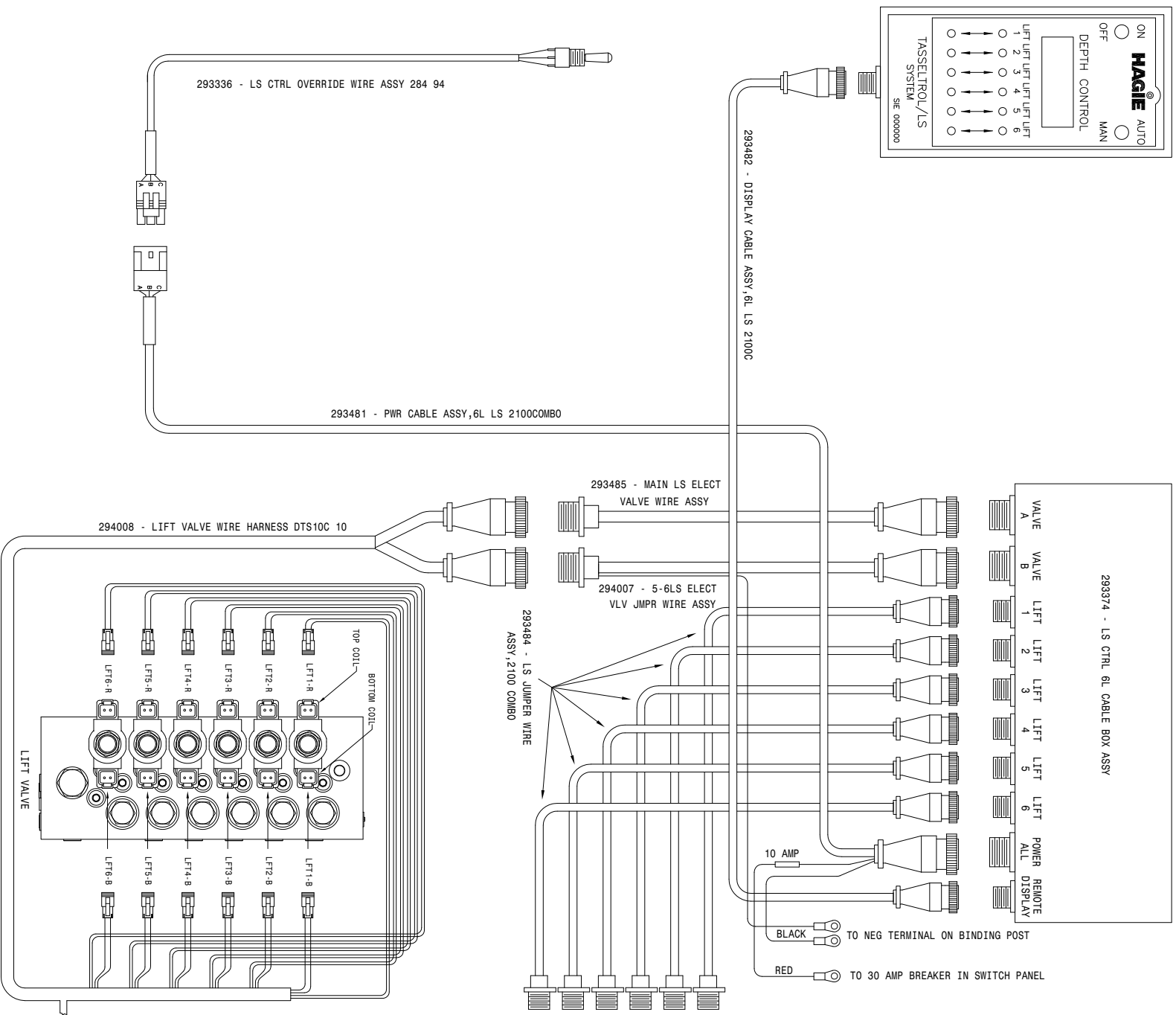

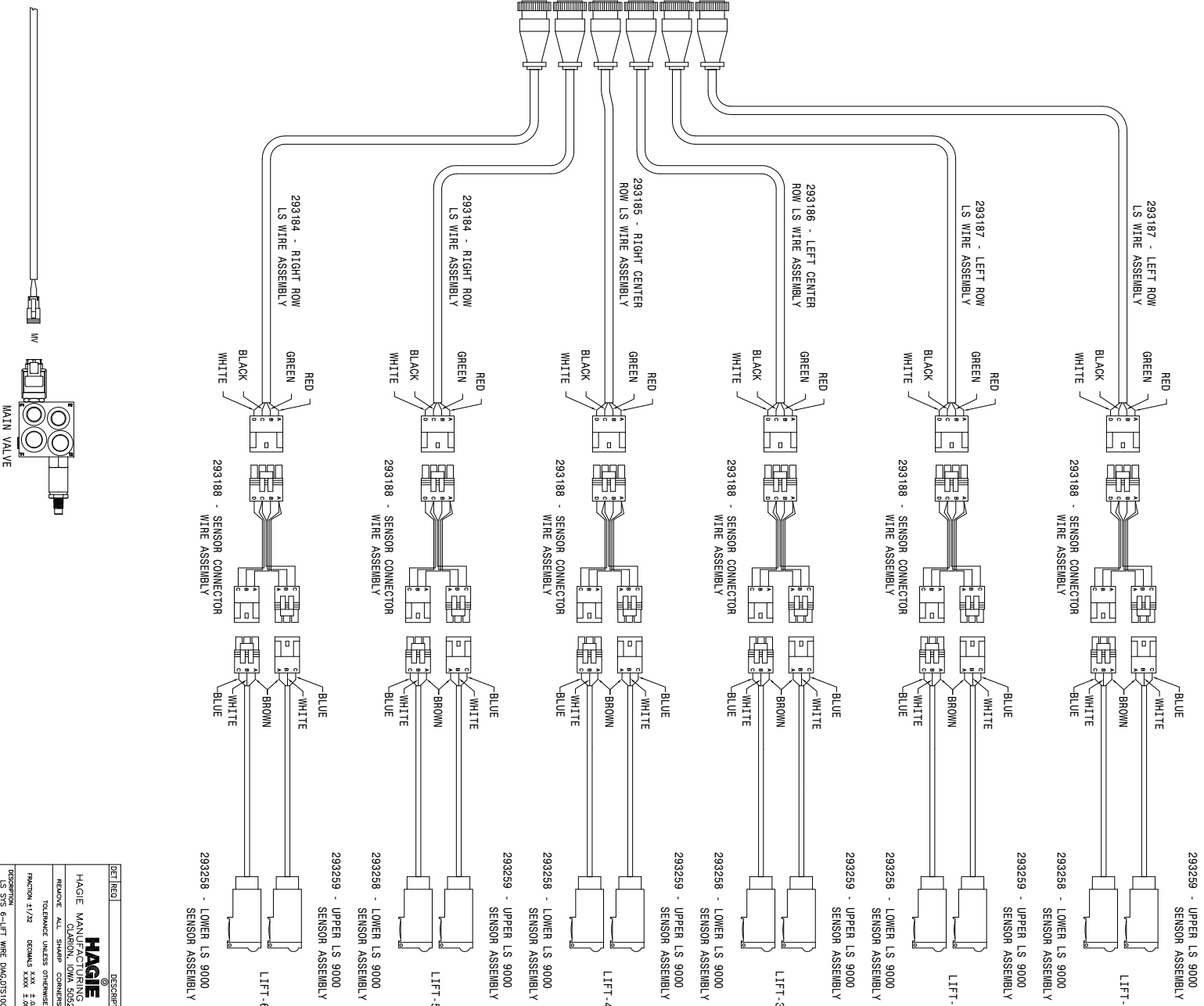

LEFT	RIGHT	DESCRIPTION
		HAGIE
		HAGIE MANUFACTURING COMPANY
		CLARION, IOWA 50525
		REMOVE ALL SHARP CORNERS & BURNS
		TOLERANCE UNLESS OTHERWISE SPECIFIED
		FRACTION 1/32 DECIMALS XXX ±.03 ANGLES 1°
		DESCRIPTION: LS 9000 & LIFT WIRE DIAG/STUD 10
		DESIGNED BY: T. LAMCKER
		SCALE: 1/16" = 1"
		DRAWN BY: T. LAMCKER
		APPROVED BY:
DATE: 07-10		DRAWING NUMBER: 499200
SHEET: 07-10		OF: 1

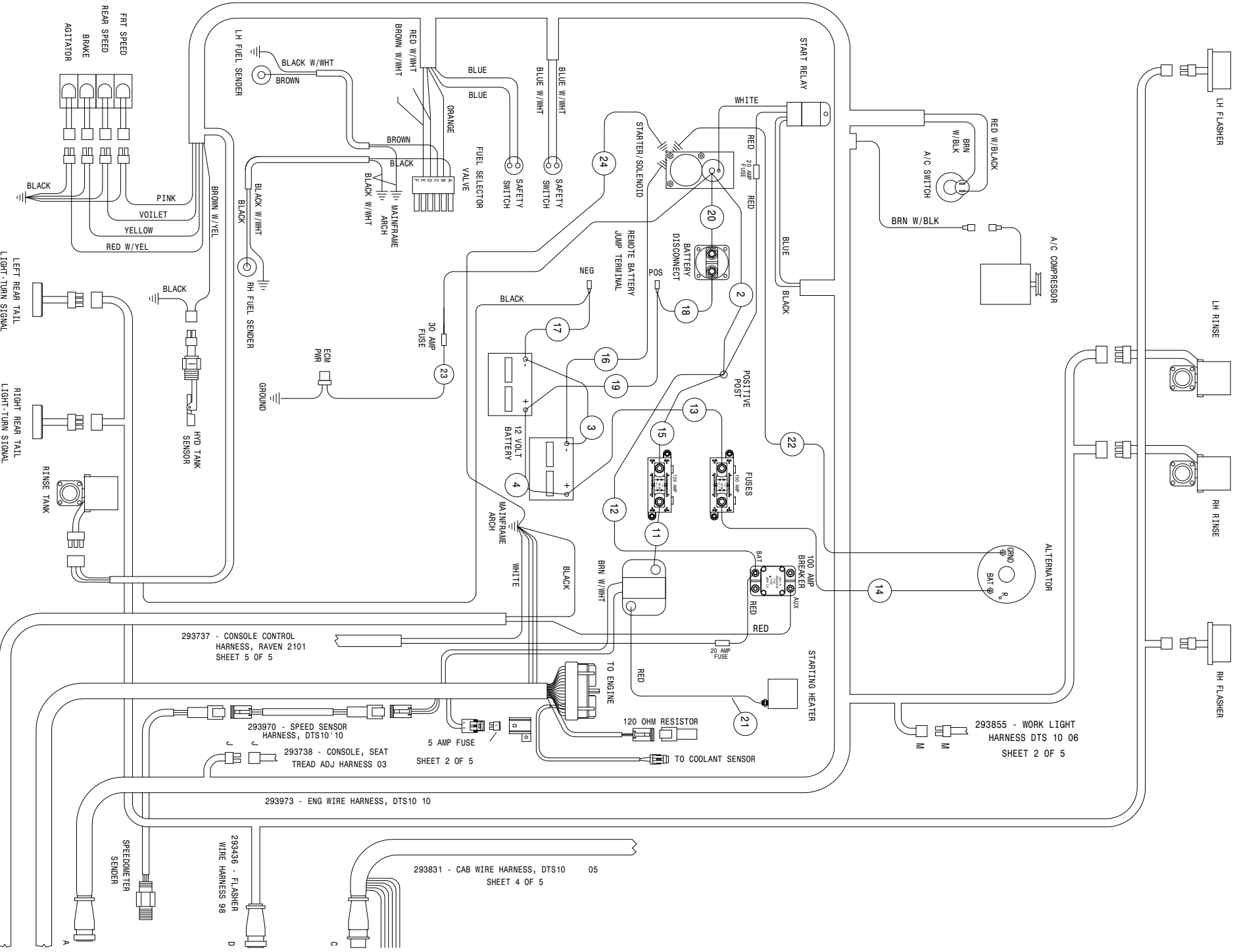

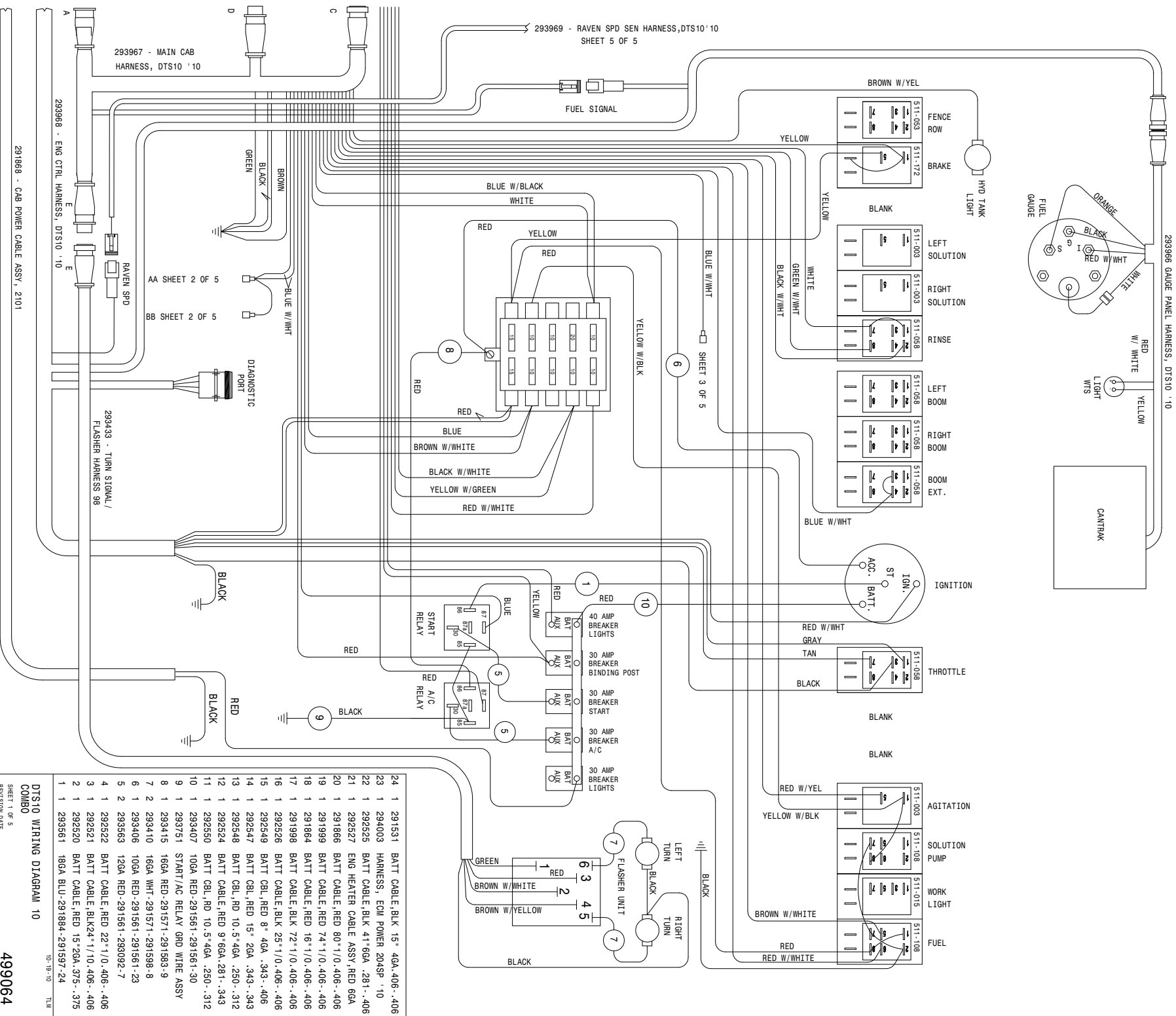

24	1	291531	BATT CABLE, BLK 15" 40A-406-.406
23	1	294003	HARNESS, ECM POWER 2049P '10
22	1	292525	BATT CABLE, BLK 41" 6GA .281-.406
21	1	292527	ENG HEATER CABLE ASSY, RED 6GA
20	1	291866	BATT CABLE, RED 80"1/0, 406-.406
19	1	291999	BATT CABLE, RED 74"1/0, 406-.406
18	1	291864	BATT CABLE, RED 16"1/0, 406-.406
17	1	291998	BATT CABLE, BLK 72"1/0, 406-.406
16	1	292526	BATT CABLE, BLK 25"1/0, 406-.406
15	1	292549	BATT CBL, RED 8" 4GA .343-.406
14	1	292547	BATT CBL, RED 15" 2GA .343-.343
13	1	292548	BATT CBL, RD 10.5" 4GA .250-.312
12	1	292524	BATT CABLE, RED 9" 6GA .281-.343
11	1	292550	BATT CBL, RD 10.5" 4GA .250-.312
10	1	293407	10GA RED-291561-291561-30
9	1	293751	START/AC RELAY GRD WIRE ASSY
8	1	293415	16GA RED-291571-291583-9
7	2	293410	16GA WHT-291571-291598-8
6	1	293406	10GA RED-291561-291561-23
5	2	293563	12GA RED-291561-293092-7
4	1	292522	BATT CABLE, RED 22"1/0, 406-.406
3	1	292521	BATT CABLE, BLK 24"1/10, 406-.406
2	1	292520	BATT CABLE, RED 15" 2GA .375-.375
1	1	293561	18GA BLU-291884-291597-24

DTS10 WIRING DIAGRAM 10
SHEET 1 OF 5
REVISION DATE
COMBO
499064
10-18-'10 TLB

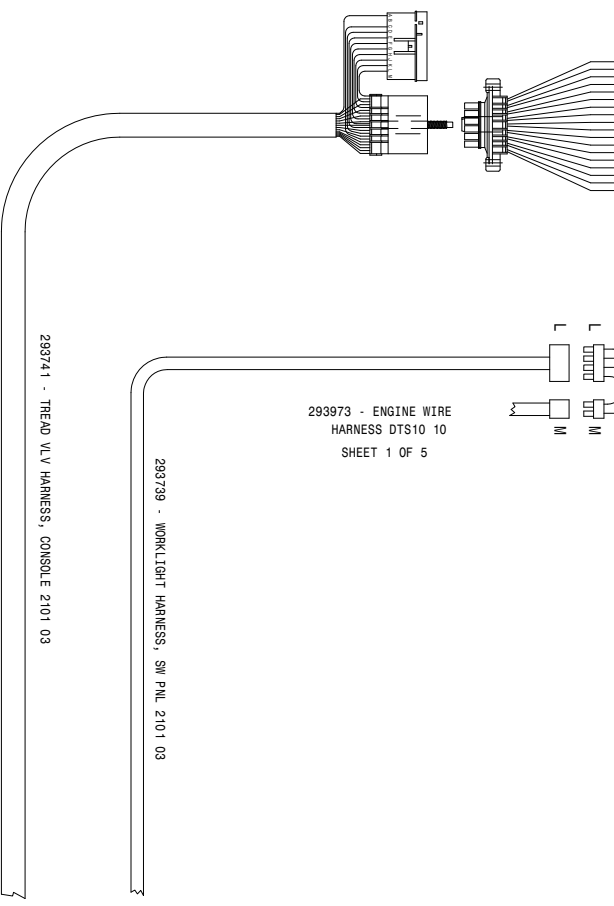
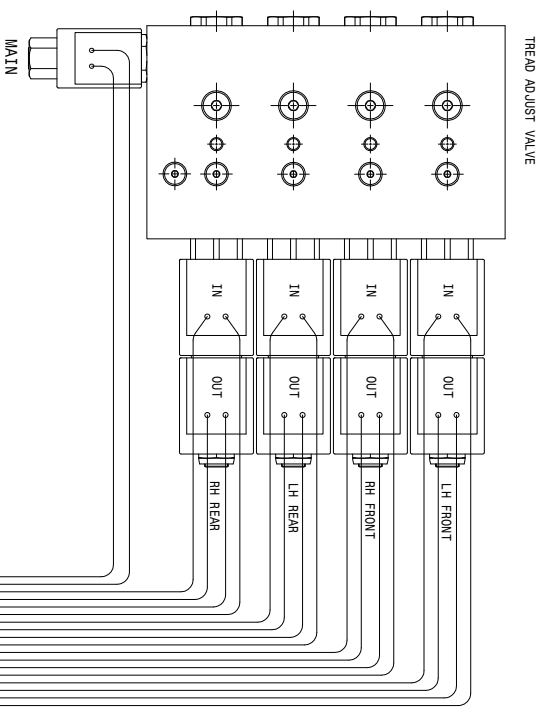
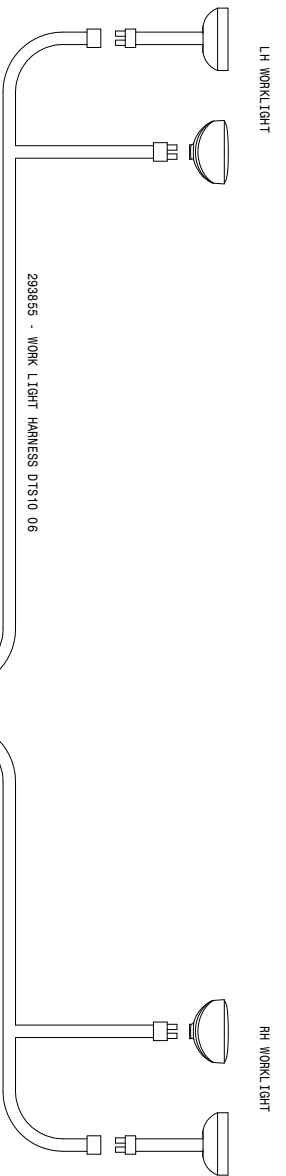

293973 - ENGINE WIRE
HARNESS DTS10 10
SHEET 1 OF 5

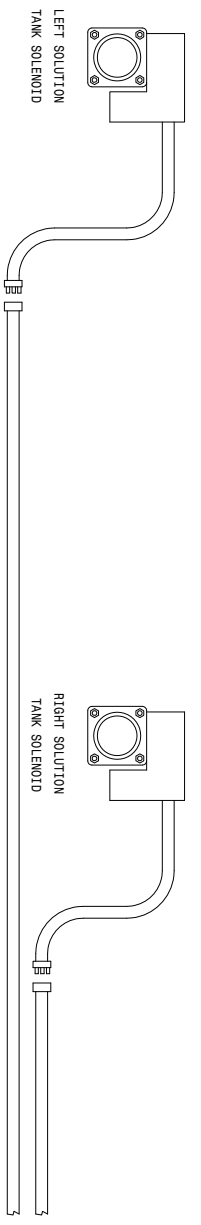

293704 - SOLU TANK VLV WIRE ASSY 03

293741 - TREAD VLV HARNESS, CONSOLE 2101 03

TO SOLUTION SWITCH
SHEET 5 OF 5

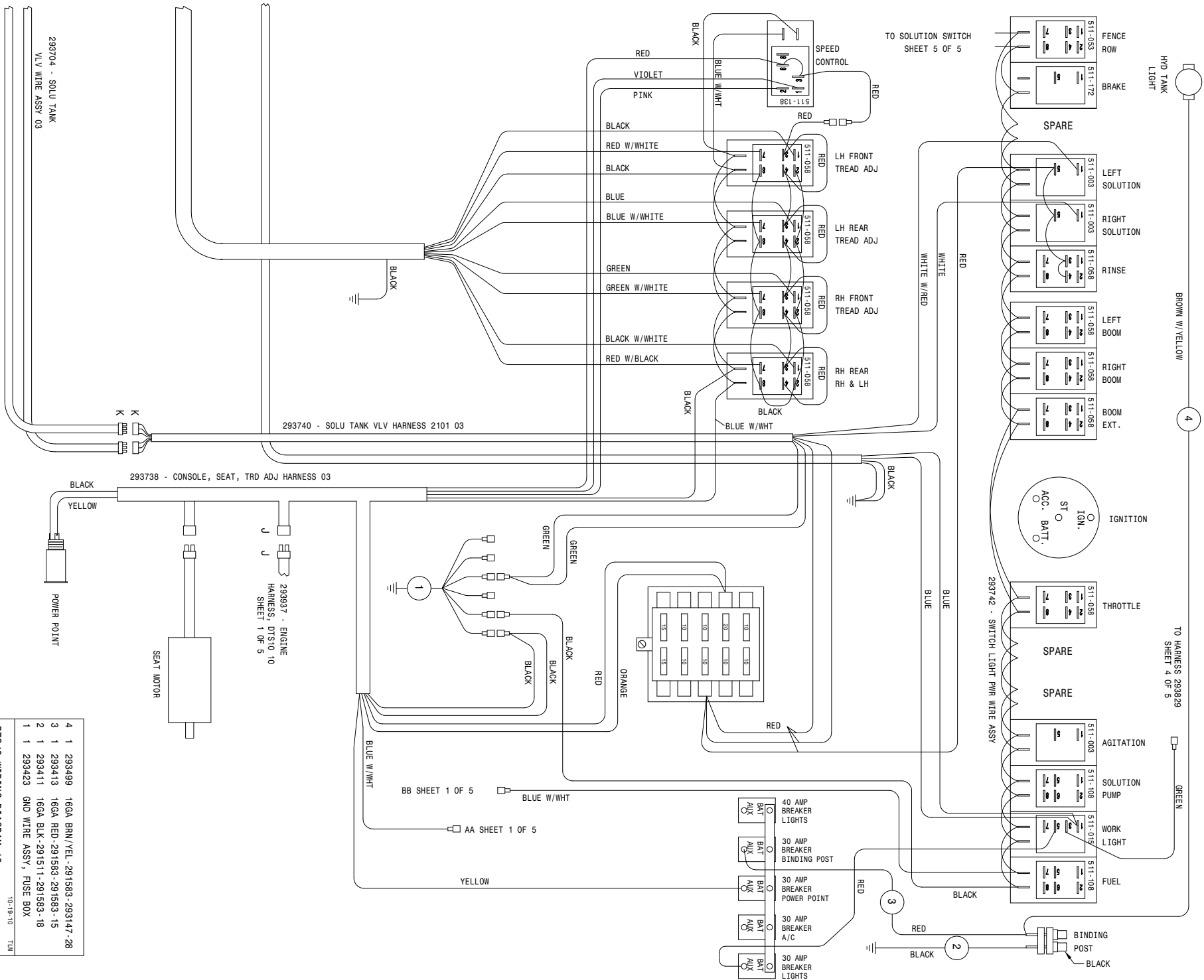

4	1	293499	166A	BRN/YEL-291583-29347-28
3	1	293413	166A	RED-291583-291583-15
2	1	293411	166A	BLK-291511-291583-18
1	1	293423	GND	WIRE ASSY, FUSE BOX

DTS10 WIRING DIAGRAM 10
COMBO
SHEET 2 OF 5
REVISION DATE: 10-19-10 TLM
499064

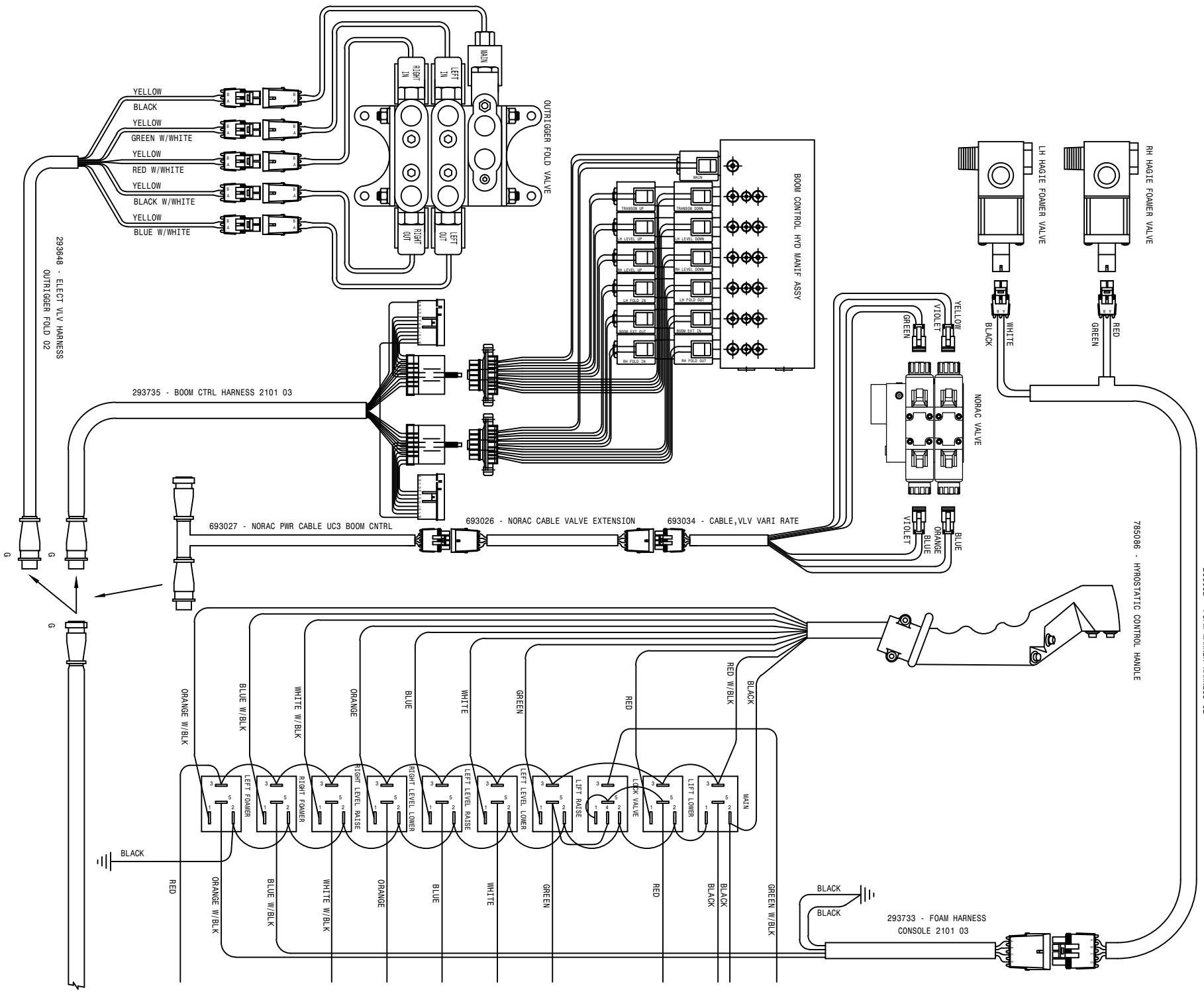

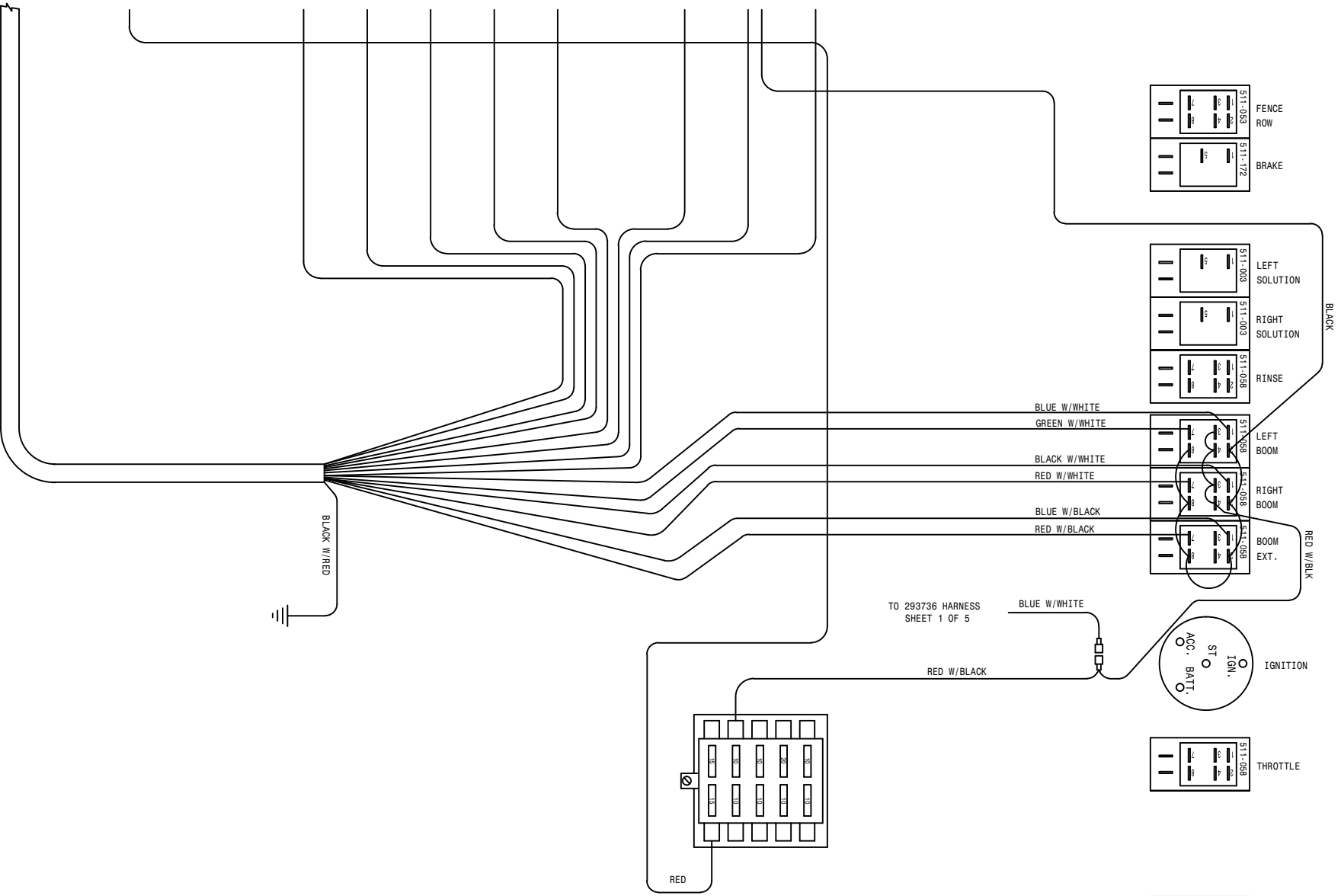

293734 - BOOM CRTL HARNESS, PNL, 2101

- 40 AMP BREAKER LIGHTS
- 30 AMP BREAKER BINDING POST
- 30 AMP BREAKER POWER POINT
- 30 AMP BREAKER A/C
- 30 AMP BREAKER LIGHTS

DTS10 WIRING DIAGRAM 1.0
 COMBO
 SHEET 3 OF 5
 REVISION DATE: 02-13-12
 499064

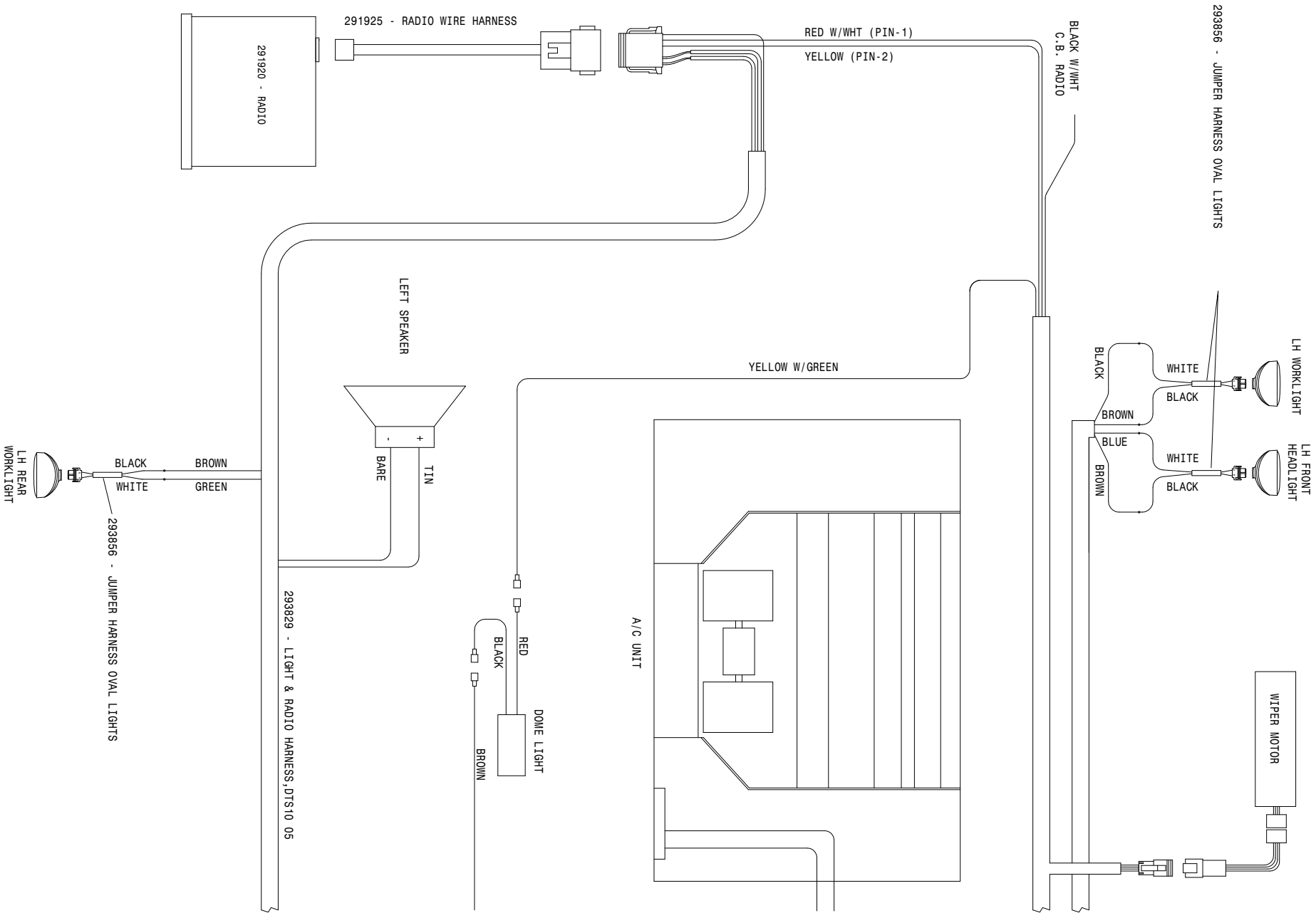

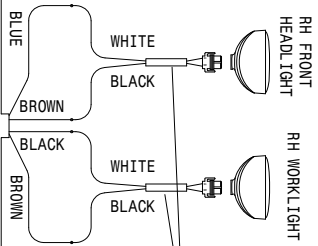

293856 - JUMPER HARNESS OVAL LIGHTS

WINDSHIELD WASHER UNIT

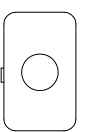

293828 - WINDSHLD WASH HARNESS, DTS10 05

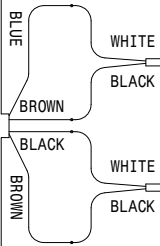

294148 - DTS10 LIGHT RELAY KIT 11

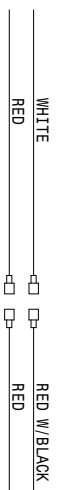

293831 - CAB WIRE HARNESS, DTS10 05

293830 - HEADLIGHT HARNESS, DTS10 05

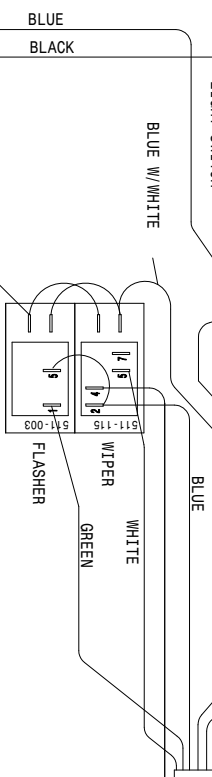

293831 - CAB WIRE HARNESS, DTS10 05

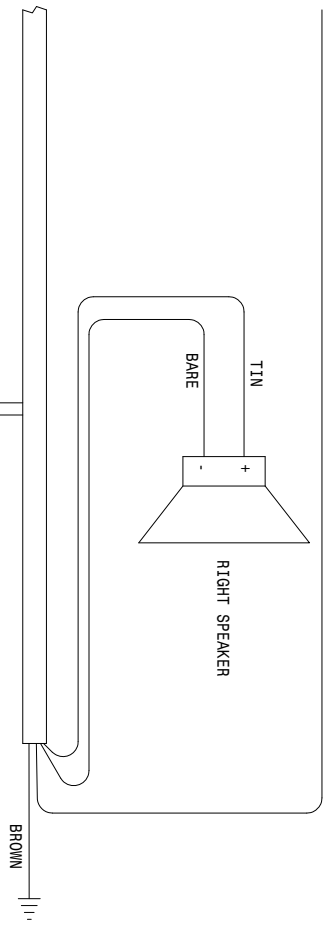

293856 - JUMPER HARNESS OVAL LIGHTS

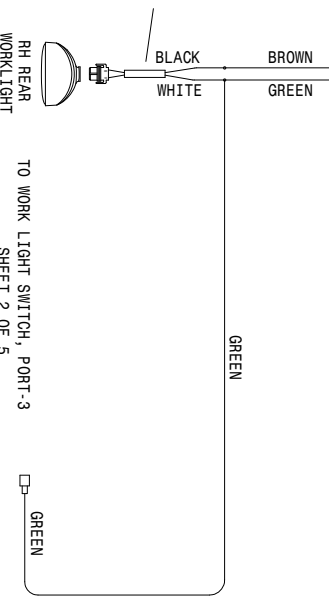

TO WORK LIGHT SWITCH, PORT-3 SHEET 2 OF 5

REFER TO SHEET 1 OF 5

DTS10 WIRING DIAGRAM 10
 COMBO
 SHEET 4 OF 5
 DIVISION DATE: 10-19-10
 499064

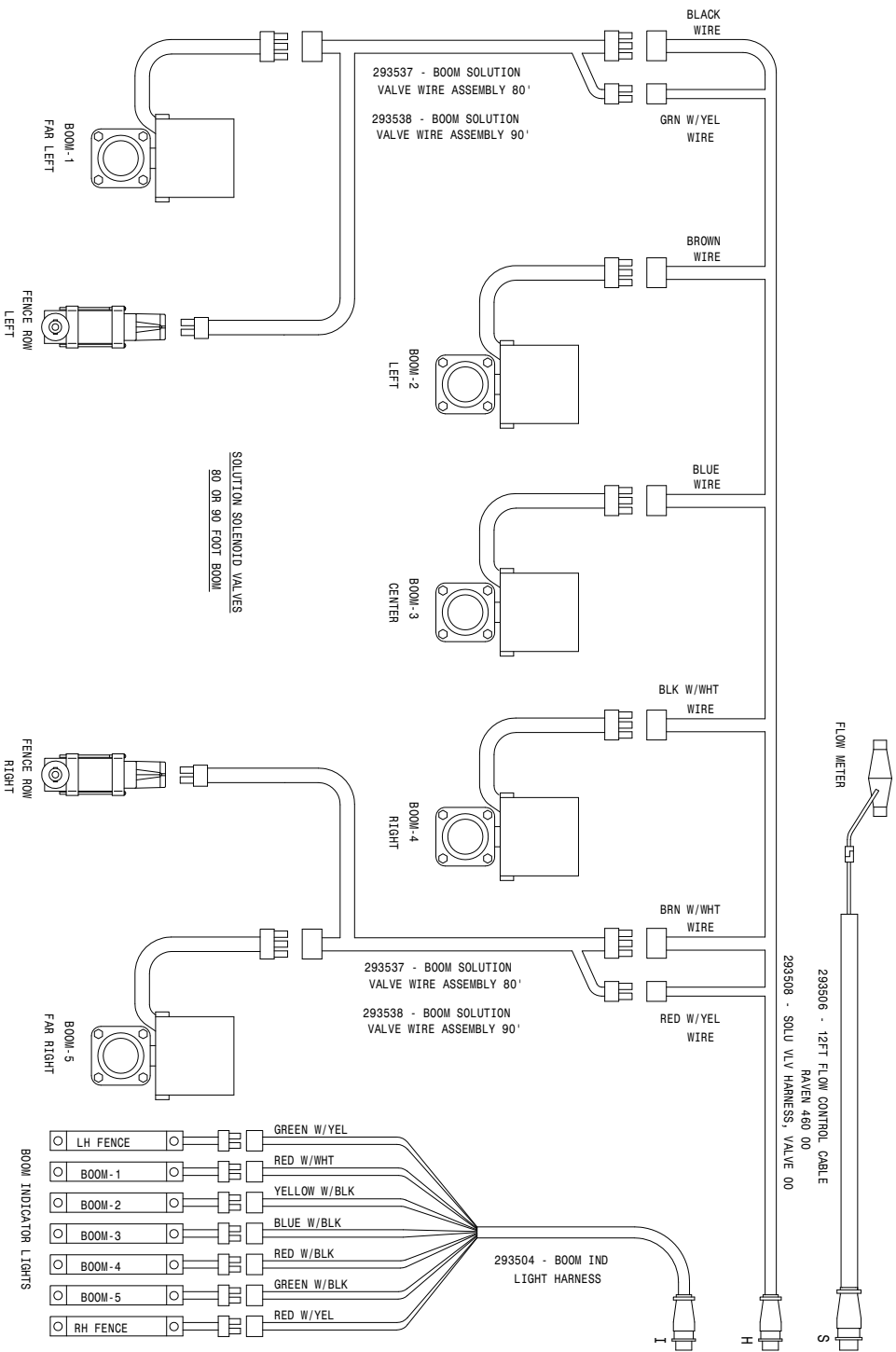
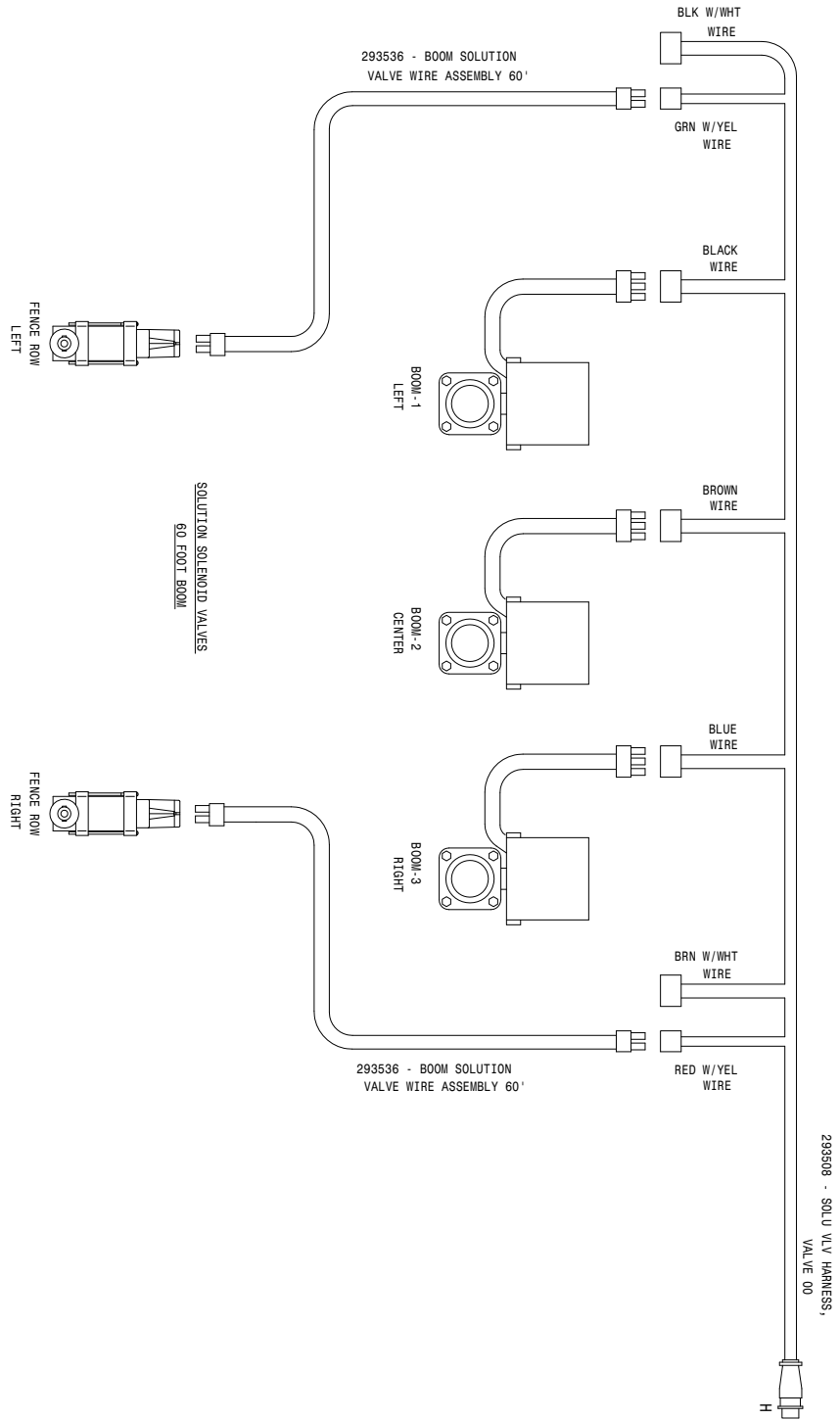

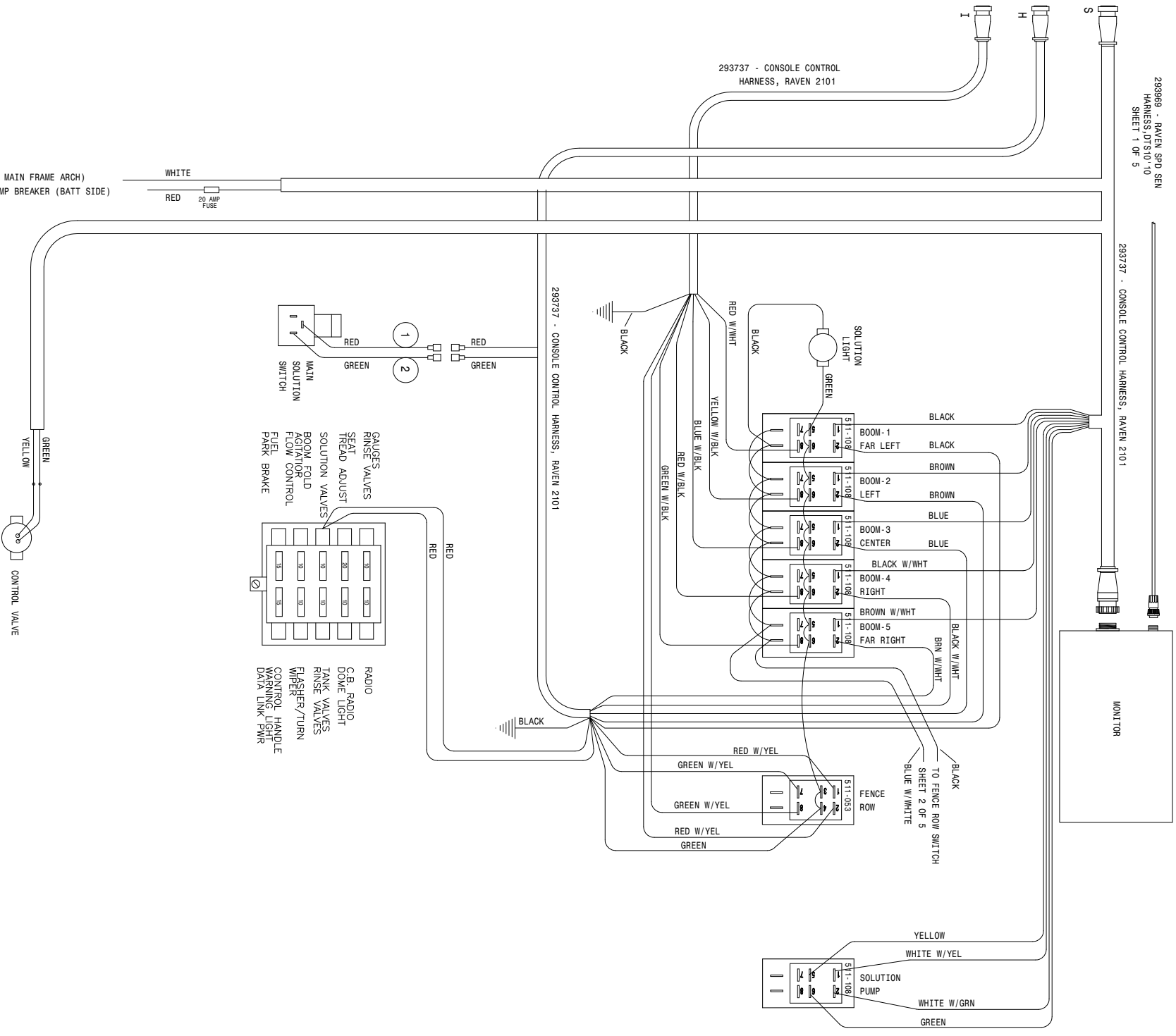

GROUND (MAIN FRAME ARCH)
TO 100 AMP BREAKER (BATT SIDE)

WHITE

RED

20 AMP FUSE

SHEET 1 OF 5

2	1	293669	1694	REV-291571-291571-45
1	1	293662	1694	REV-291571-291571-45
DTS10 WIRING DIAGRAM 10				
COMBO				
REVISION DATE: 10-19-10 TLM				
4990064				

DTS10 COMBO HYDRAULIC SCHEMATIC 2010
REFERENCE DRAWING NO. 49906551

DET.	QTY	PART NO.	DESCRIPTION	DET.	QTY	PART NO.	DESCRIPTION
1	1	606929	SUND GEAR PUMP .66CI, SPLINED	74	2	618311	3/4MJC UNION TEE
2	1	606353	GEAR PUMP,5.38CI	75	1	470308	1/2MNP DRAIN PLUG,AL HD,MAG
3	1	606231	SUND 75CC PUMP,C/C MT (.022)	76	2	503600	CLOSE NIPPLE .50NPT
4	1	606234	SUND 75CC PUMP, C/B MT (.022)	77	1	503820	BLK PIPE TEE .50NPT
5	2	610637	SUND HYD MOTOR, M46-4019	78	1	503824	BLK PIPE CROSS .50NPT
6	1	608000	SAUER HYD MOTOR, M46-4024	79	1	504210	RED BUSH 3/4 NPT X 1/2 NPT
7	1	608004	SAUER WHL MOTOR, M46-4194	80	1	504610	BLK PIPE ST EL 90DEG .75NPT
8	2	610803	TORQ HUB,7HBA 24.40:1 W/BRAKE	81	2	504702	CLOSE NIPPLE .75NPT
9	1	618606	OIL COOLER, BLISSFIELD 65027	82	2	504955	BLK PIPE TEE .75NPT
10	1	605600	TANK FILTER, 100 MESH,1"FNPT	83	1	505213	RED BUSH 1 X 3/4 BLK MAL
11	1	605601	PARKER FILTER ASSY, 10M,1.25NPT	84	3	505300	BLK PIPE EL 90DEG 1.00NPT
12	2	610505	LINE SUMP DIFUSER	85	1	506105	BLK PIPE TEE 1.25NPT
13	1	611452	FILLER BREATHER 3/4NPT	86	1	506200	CLOSE NIPPLE 1.25NPT
14	1	614453	DIPSTICK, 8IN	87	1	506303	BLK PIPE EL 90DEG 1.25NPT
15	1	760090	RECEIVER PLT WLD 8240	88	3	506410	BLK PIPE ST EL 90DEG 1.25NPT
16	1	760268	HYD TANK WLD, 2100 2002	89	1	506609	BLK PIPE NIPPLE 1.25NPT-6.00
17	1	605608	HYD FILTER HEAD, DONALDSON	90	2	610305	3/4MJC-90-3/4NPT LBO
18	1	605609	HYD FILTER ELEMENT, DONALDSON	91	1	618018	9/16MJC-1/2MNP ADPTR
19	2	610580	REMOTE FLUSHING VALVE, SUND	92	3	618107	9/16MJC-90-1/2MNP LBO
20	3	606138	HYD SOLE VLV,2P-3W,9/16FOR, WP	93	1	615737	08-381-08F3X-08F3X90-198
21	4	615724	FRT MAIN HYD TUBE ASSY,2100 98	94	1	616254	04-381-06F3X-06F3X-26
22	1	615718	RH FRT PUMP LMR TUBEASSY210098	95	2	715664	1 1/4 NPT X 1 HOSE BARB
23	1	615717	LH FRT PUMP UPR TUBEASSY210098	96	2	611262	04-4821C-06F3X-06F3X-182
24	1	615719	LH FRT PUMP LMR TUBEASSY210098	97	2	614152	04-4821C-06F3X-06F3X-114
25	1	615720	RH REAR PUMP UPR TUBE ASSY 98	98	4	614157	04-4821C-06F3X-06F3X-101
26	1	615721	RH REAR PUMP LMR TUBE ASSY 98	99	2	614546	08-4821C-08F3X-08F3X-115
27	1	615722	LH REAR PUMP UPR TUBE ASSY 98	100	2	614688	08-4821C-08F3X-08F3X-108
28	1	615723	LH REAR PUMP LMR TUBE ASSY 98	101	1	614713	04-4821C-06F3X-06F3X-24
29	4	615708	LMR HYD TUBE ASSY,LEG 2100 98	102	4	614734	12-721-12M3-12M3-16
30	2	615709	UPR HYD TUBE ASSY,LEG 2100 98	103	1	616026	04-4821C-06F3X-06F3X-37
31	2	615710	RF/LR HYD DRN TUBE ASSY2100 98	104	1	614383	08-4821C-08F3X-08F3X-26
32	2	615712	LF/RR HYD CTRL TUBE ASSY210098	105	2	616255	04-381-06F3X-06F3X-29
33	2	615809	LF/RR HYD CTRL TUBE ASSY210098	106	1	616039	04C1T-06F3X-06F3X-19
34	2	615713	RH HYD BRAKE TUBE ASSY,2101 04	107	2	616253	04-381-06F3X-06F3X-23
35	1	615815	LH HYD BRAKE TUBE ASSY,2101 04	108	3	616056	04-4821C-06F3X-06F3X-32
36	1	615814	9/16MJC-90-9/16MOR LBO	109	4	618314	3/4MJC UNION
37	8	618119	9/16MJC-45-9/16FJIC SWIV LBO	110	6	619010	9/16MJC UNION
38	2	618634	1 5/16MJC-90-1 5/16MOR LBO	111	4	618177	1 1/16MJC UNION
39	8	618178	3/4MJC-90-1 1/16MOR LBO	112	3	614735	12-721-16F3X-16F3X-75
40	6	618474	9/16MJC-7/16MOR ADPTR	113	1	614736	12-721-16F3X-12F3X90-75
41	2	618304	PIPE PLUG,1.00NPT SQ HD	114	2	614737	12-721-16F3X-12F3X90-99
42	2	505102	BLK PIPE ST EL 90DEG 1.00NPT	115	2	614738	12-721-16F3X-12F3X90-114
43	5	505200	BLK PIPE NIPPLE 1.00NPT-4.00	116	2	615626	08-4821C-08F3X-08F3X-15
44	1	714331	1 NPT X 3/4 HOSE BARB	117	2	616252	04-381-06F3X-06F3X-13
45	1	601599	HOSE, 1 X 32 1FBR-1SPI	118	2	614739	08-4821C-08F3X-08F3X90-16
46	1	505101	BLK PIPE TEE 1.00NPT	119	1	614712	04-4821C-06F3X-06F3X-20
47	2	507026	1 1/4MNP TEE PIPE NIPPLE STL	120	2	615725	04-4821C-06F3X-06F3X-10
48	1	611126	7/8MJC-7/8MOR ADPTR	121	1	601384	HOSE, 3/4 X 40 1FBR-1SPI
49	2	618734	9/16JIC .047 ORIFICE ADPTR	122	1	601384	HOSE, 1 X 39 1FBR-1SPI
50	1	618816	1 7/8MOR-1 1/4FNPT ADPTR	123	1	601384	HOSE, 1 X 48 1FBR-1SPI
51	1	618118	3/4 HOSE BARB-90-1 1/16MOR	124	1	616858	12-881-16F3X-12F3X90-67
52	1	618227	9/16MOR BRANCH TEE-9/16MJC	125	1	618619	1 5/16F3 SW RUN TEE-1 5/16MJC
53	9	618327	3/4MJC-7/8MOR ADPTR	126	1	601377	HOSE, 1 X 48 1FBR-1SPI
54	4	618629	BLK PIPE CROSS 1.25NPT	127	1	616860	16-881-16F3X-16F3X-108
55	4	618531	9/16FJIC CAP NUT	128	1	616857	12-881-12F3X-16F3X90-92
56	4	505105	1MNP HEX PIPE NIPPLE STL	129	1	615465	08-4821C-08F3X-08F3X-33
57	1	618477	1 5/8MJC-90-1 5/8MOR LBO	130	1	616859	12-881-12F3X-16F3X-33
58	1	618126	9/16F3 SW BRANCH TEE-9/16MJC	131	2	615808	UPR HYD TUBE ASSY,LEG 2100 03
59	8	618514	1" 4-BOLT FLG X 1 5/16 FOR	132	2	606139	HYD SOLE VLV,2P3W,3/4FOR, WP
60	1	618598	1 5/16MOR BRANCH TEE-1 5/16MJC	133	2	618115	9/16MJC-90-3/4MOR LBO
61	4	618599	1 5/16MOR BRANCH TEE-1 5/16MJC	134	1	618109	9/16MJC-3/4MOR ADPTR
62	4	618541	1 5/16MJC-1 1/16MJC ADPTR	135	2	618322	1 5/16MJC-1MNP ADPTR
63	5	618640	1 5/16MJC-90-1 5/16F3 SWIV LBO	136	1	618717	1 5/16F3X BRANCH TEE-1 5/16MJC
64	2	618075	3/4 HOSE BARB-1 1/16MOR	137	1	505109	STL PIPE BRG, 1.00NPT
65	1	618643	3/4F3 SW BRANCH TEE-3/4MJC	138	1	505201	CLOSE NIPPLE 1.00NPT
66	2	618577	1 5/16MJC UNION	139	1	618437	1 5/16MJC-90-1MNP LBO
67	11	618486	9/16FJIC SW RUN TEE-9/16MJC	140	1	618519	1 1/16MJC-90-1MNP LBO
68	3	618564	1IN HOSE BARB-90-1 5/16MOR	141	1	618313	1 1/16MJC-45-1 1/16MOR LBO
69	2	714560	1NPT X 1 HOSE BARB	142	2	506005	1 1/4 TO 1 RED BUSH BLK MAL
70	2	716000	3/4 HOSE BARB-90-1MNP	143	1	715660	HOSE BARB 1 1/4NPT X 1 1/4
71	1	618618	9/16MJC-90-9/16FJIC SWIV LBO	144	2	618451	3/4FJIC SW RUN TEE-3/4MJC
72	2	618019		145	2	618609	3/4MJC-90-3/4FJIC SWIV LBO
73	3	618019					

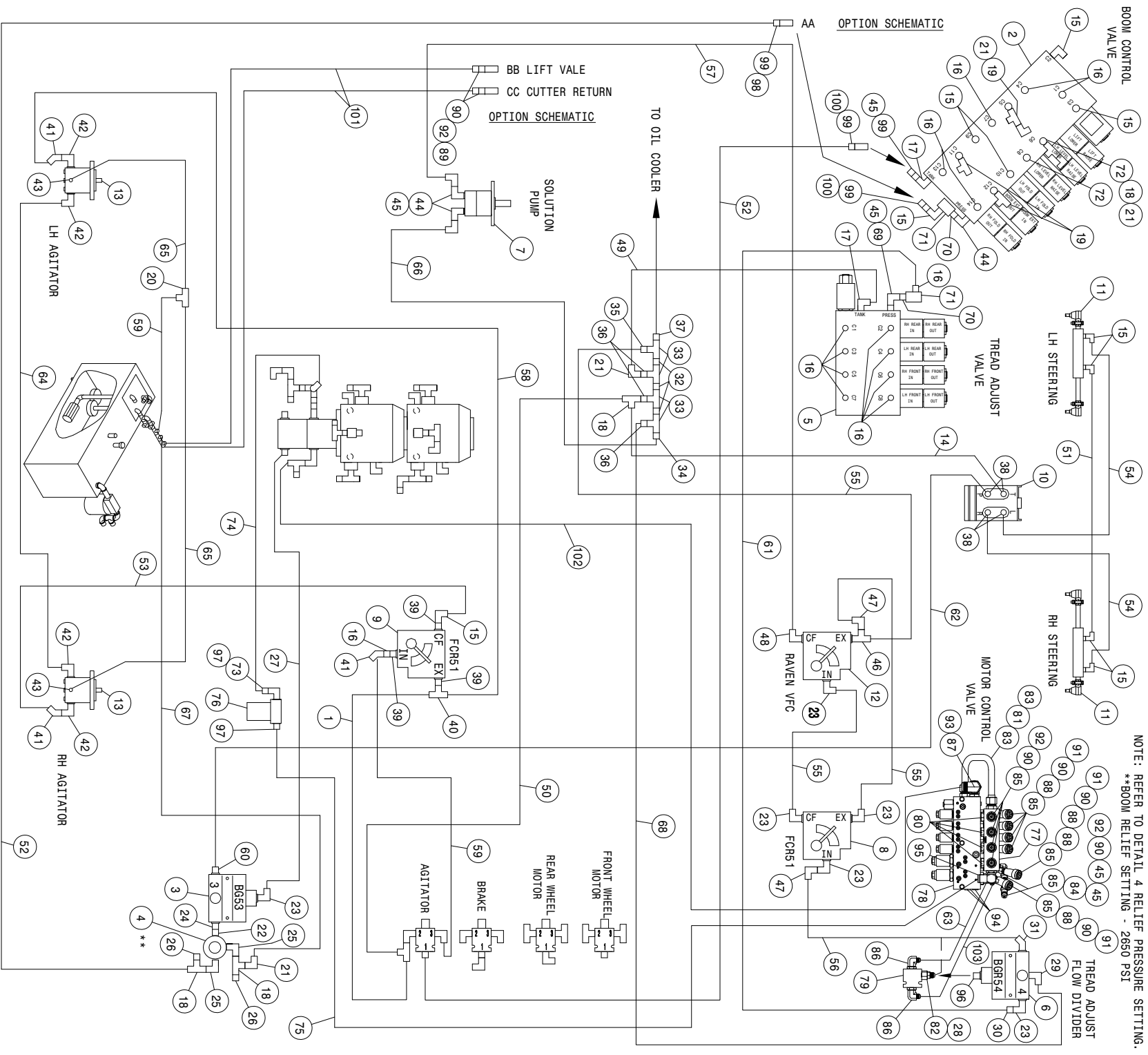

NOTE: REFER TO DETAIL 4 RELIEF PRESSURE SETTING.
 **BOOM RELIEF SETTING - 2650 PSI

DTS10 COMBO HYDRAULIC SCHEMATIC 2010
REFERENCE DRAWING NO. 49906552

DET.	QTY	PART NO.	DESCRIPTION	DET.	QTY	PART NO.	DESCRIPTION	
1	1	615621	06-482TC-06FJX-06FJX-24	H/A	53	614549	06-482TC-06FJX-06FJX-140	H/A
2	1	606104	BOOM CTRL VLV, STS PMSYS 03	54	2	614639	04-482TC-06FJX-06FJX-126	H/A
3	1	610307	FLO DIV BG53 36PM PRI 7/8FOR	55	3	614732	10-381-10FJX-10FJX-29	H/A
4	1	607512	RELIEF VALVE, RL50, 1850 PSI	56	1	616940	10-381-10FJX-10FJX-104	H/A
5	1	606107	TREAD ADJ VLV,2101 PMSYS 03	57	1	616057	08-482TC-08FJX-08FJX-88	H/A
6	1	607528	FLO DIV BGR54 4GPM PRI 7/8FOR	58	1	615348	06-482TC-06FJX-06FJX-127	H/A
7	1	690573	HYD MOTOR, FLOMAX HI-SPEED	59	2	615401	06-482TC-06FJX-06FJX-22	H/A
8	1	606818	FLO CONT FCR51 0-16GPM 7/8FOR	60	1	618310	9/16MJIC-7/8MOR ADPTR	H/A
9	1	606827	FLO CONT FCS1 0-3 VARI 7/8FOR	61	1	615728	04-482TC-06FJX-06FJX-80	H/A
10	1	749318	STRG MTR, 7.3CID, NON-LOAD 1031	62	1	615730	04-482TC-06FJX-06FJX-150	H/A
11	2	621516	HYD CYL, 2.00 X 7.00 X 1.000	63	1	616192	08-482TC-08FJX-08FJX-21	H/A
12	1	690621	VALVE HYD CTRL,16GPM RAVEN	64	1	615732	06-482TC-06FJX-06FJX-194	H/A
13	2	606324	GEAR MTR,1.4ICI EATON	65	2	615733	06-482TC-06FJX-06FJX-101	H/A
14	1	616049	04-482TC-06FJX-06FJX-26	H/A	66	615736	08-381-08FJX-08FJX-46	H/A
15	10	618119	9/16MJIC-90-9/16MOR LBO	67	1	615442	04-482TC-06FJX-06FJX-55	H/A
16	15	618126	9/16MJIC-9/16MOR ADPTR	68	1	616172	04-482TC-06FJX-06FJX-60	H/A
17	2	618115	9/16MJIC-90-3/4MOR LBO	69	1	611125	3/4MJIC-3/4MOR ADPTR	H/A
18	4	618486	9/16FJIC SW RUN TEE-9/16MJIC	70	2	618692	3/4FJIC SWIV-9/16MOR ADPTR	H/A
19	3	618444	9/16MOR RUN TEE-9/16MJIC	71	2	605615	HYD FILTER,INLINE 25M 9/16FOR	H/A
20	1	618019	9/16MJIC UNION TEE	72	2	614763	9/16MJIC-9/16MOR, .0420RF ADPTR	H/A
21	4	618618	9/16MJIC-90-9/16FJIC SWIV LBO	73	1	506410	BLK PIPE ST EL 90DEG 1.25NPT	H/A
22	1	500000	1/2MNPT HEX PIPE NIPPLE STL	74	1	601744	HOSE, 1 1/4 X 29 1FBR-1SPI	H/A
23	5	611128	7/8MJIC-90-7/8MOR LBO	75	1	601745	HOSE, 1 1/4 X 165 1FBR-1SPI	H/A
24	1	618072	7/8MOR-1/2FNPT ADPTR	76	1	605633	PARKER FILTER ASSY,25M,1.25NPT	H/A
25	2	618107	9/16MJIC-90-1/2MNPT LBO	77	1	606029	RETURN MANIFOLD BLOCK, STS 03	H/A
26	2	618531	9/16FJIC CAP NUT	78	1	606262	MTR CONTROL ELECT VLV, SAUER 07	H/A
27	1	614744	10-381-10FJX-10FJX-18	H/A	79	606356	1 1/16FOR MANIFOLD,3 #12PORTS	H/A
28	1	611126	7/8MJIC-7/8MOR ADPTR	80	4	610186	1 1/16MOR PLUG, HEX HEAD	H/A
29	1	618015	9/16MJIC-90-3/8MNPT LBO	81	1	615812	MTR CTRL RET TUBE ASSY,DTS10	H/A
30	1	618557	7/8FJIC-9/16MJIC ADPTR	82	1	618132	1 1/16MOR-7/8FOR ADPTR	H/A
31	1	618644	7/8MJIC-45-7/8MOR LBO	83	2	618186	1 5/16MJIC-1 5/16MOR ADPTR	H/A
32	3	504702	CLOSE NIPPLE .75NPT	84	2	618451	3/4FJIC SW RUN TEE-3/4MJIC	H/A
33	4	504955	BLK PIPE TEE .75NPT	85	12	618469	3/4MJIC-1 1/16MOR ADPTR	H/A
34	1	610300	3/4MJIC-3/4MNPT ADPTR	86	2	618474	3/4MJIC-90-1 1/16MOR LBO	H/A
35	1	618509	7/16MOR RUN TEE-7/16MJIC	87	1	618476	1 5/8MJIC-90-1 5/16MOR LBO	H/A
36	3	618642	9/16MJIC-3/4MNPT ADPTR	88	7	618590	3/4MJIC-45-3/4FJIC SWIV LBO	H/A
37	1	618108	1 1/16MJIC-3/4MNPT ADPTR	89	2	618349	3/4MJIC-3/4MJIC BLKHD UNION	H/A
38	4	618109	9/16MJIC-3/4MOR ADPTR	90	14	618669	3/4FJIC SWIV-3/4MOR ADPTR	H/A
39	3	618172	7/8MOR-9/16FOR ADPTR	91	6	618696	HYD COUPLER,FEM 1/2B, 3/4FOR	H/A
40	1	618629	9/16MOR BRANCH TEE-9/16MJIC	92	6	618697	HYD COUPLER,MALE 1/2B, 3/4FOR	H/A
41	3	618634	9/16MJIC-45-9/16FJIC SWIV LBO	93	1	618721	1 5/8MOR-90-1 5/8FJ SWIV LBO	H/A
42	4	618813	9/16MJIC-90-1 1/16MOR LBO	94	3	618753	7/16MOR PLUG, HEX SOCKET	H/A
43	2	618425	9/16MJIC-45-9/16MOR LBO	95	1	618772	1 1/4 HOSE BARB-90-1 5/16MOR	H/A
44	3	618241	3/4MJIC-90-3/4MOR LBO	96	1	618594	7/8FJIC SWIV-7/8MOR ADPTR	H/A
45	6	618609	3/4MJIC-90-3/4FJIC SWIV LBO	97	2	715660	HOSE BARB 1 1/4NPT X 1 1/4	H/A
46	1	618130	7/8MOR RUN TEE-7/8MJIC	98	2	618645	HYD QUICK CPLR,FEMALE .375NPS	H/A
47	1	618301	7/8MJIC-90-7/8FJIC SWIV LBO	99	4	618011	9/16MJIC-3/8MNPT ADPTR	H/A
48	1	618183	3/4MJIC-90-7/8MOR LBO	100	2	618646	HYD QUICK CPLR, MALE .375NPS	H/A
49	1	616037	04-482TC-06FJX-06FJX-29	H/A	101	614746	08-482TC-08FJX-08FJX-228	H/A
50	1	614693	06-482TC-06FJX-06FJX-168	H/A	102	616941	20-381-20FJX-20FJX-176	H/A
51	1	611262	04-482TC-06FJX-06FJX-182	H/A	103	615385	08-482TC-08FJX-08FJX-29	H/A
52	2	615735	06-482TC-06FJX-06FJX-300	H/A				H/A

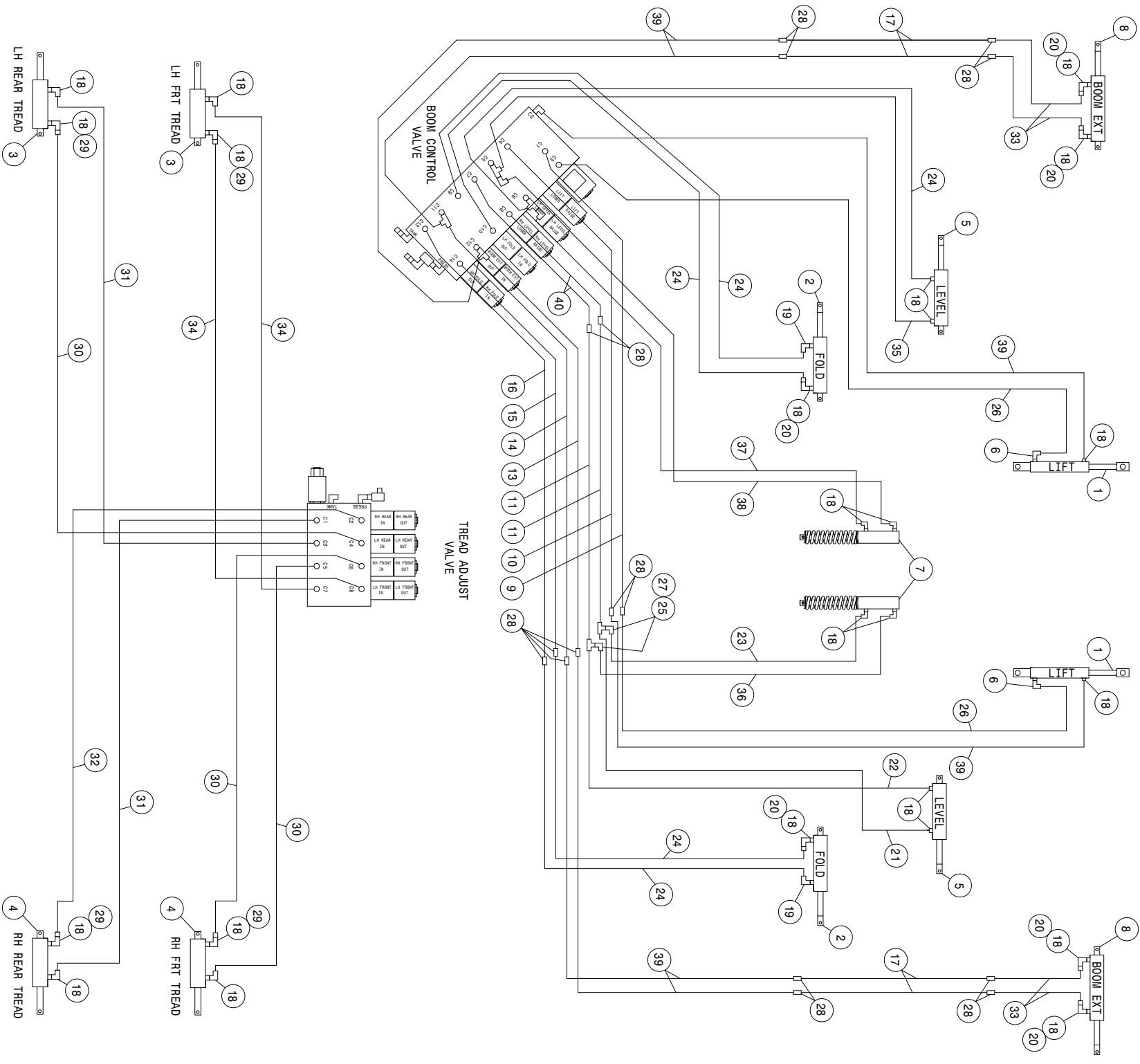

DTS10 COMBO HYDRAULIC SCHEMATIC 2010
REFERENCE DRAWING NO. 49906553

DET.	QTY	PART NO.	DESCRIPTION	DET.	QTY	PART NO.	DESCRIPTION
1	2	621518	HYD CYL, 2.50 X 14.00 X 1.250	21	1	616028	04-482TC-06FJX-06FJX-47
2	2	621520	HYD CYL, 2.00 X 10.00 X 1.000	22	1	614714	04-482TC-06FJX-06FJX-34
3	2	621534	HYD CYL, 2.50 X 12.00 X 1.250	23	1	616049	04-482TC-06FJX-06FJX-26
4	2	621536	HYD CYL, 2.50 X 12.00 X 1.250	24	5	615442	04-482TC-06FJX-06FJX-55
5	2	621522	HYD CYL, 2.00 X 10.00 X 1.000	25	2	618618	9/16MJIC-90-9/16FJIC SWIV LBO
6	2	618689	9/16MJ-90-9/16MOR .042 CHK VLV	26	2	616174	04-482TC-06FJX-06FJX-70
7	2	621524	HYD CYL, 2.00 X 4.00 X 1.000	27	2	618019	9/16MJIC UNION TEE
8	2	621526	HYD CYL, 2.50 X 16.94 X 1.250	28	16	619010	9/16MJIC UNION
9	1	615761	LIFT RAISE HYD TUBE ASSY	29	4	618731	9/16JIC .025 ORIFICE ADPTR
10	1	615762	LIFT LOWER HYD TUBE ASSY	30	3	611204	04-482TC-06FJX-06FJX-78
11	2	615813	LEVEL HYD TUBE ASSY	31	2	614077	04-482TC-06FJX-06FJX-88
12	1	615764	LEVEL LOWER HYD TUBE ASSY	32	1	615726	04-482TC-06FJX-06FJX-73
13	1	615766	BOOM EXTN RAISE HYD TUBE ASSY	33	4	616043	04-482TC-06FJX-06FJX-23
14	1	615767	BOOM EXTN LOWER HYD TUBE ASSY	34	2	615729	04-482TC-06FJX-06FJX-84
15	1	615768	RH FOLD RAISE HYD TUBE ASSY	35	1	614715	04-482TC-06FJX-06FJX-43
16	1	615769	RH FOLD LOWER HYD TUBE ASSY	36	1	614712	04-482TC-06FJX-06FJX-20
17	4	615684	HYD TUBE ASSY,BOOM EXT FOLD96	37	1	614713	04-482TC-06FJX-06FJX-24
18	24	618119	9/16MJIC-90-9/16MOR LBO	38	1	616037	04-482TC-06FJX-06FJX-29
19	2	618688	9/16MJ-90-9/16MOR .025 CHK VLV	39	6	616040	04-482TC-06FJX-06FJX-67
20	6	618733	9/16JIC .042 ORIFICE ADPTR	40	2	614033	04-482TC-06FJX-06FJX-17

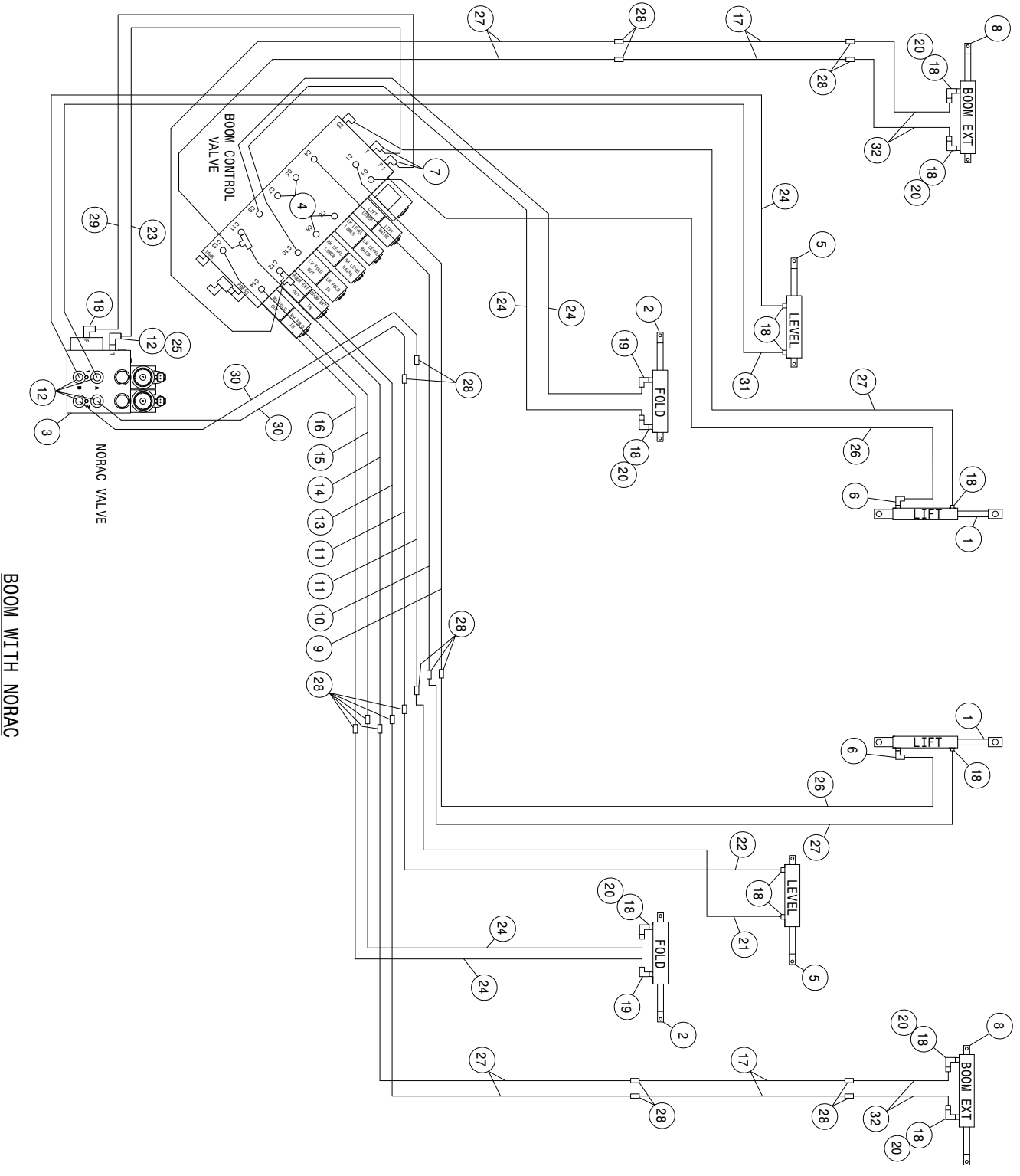

BOOM WITH NORAC

DTS10 COMBO HYDRAULIC SCHEMATIC 2010
REFERENCE DRAWING NO. 499065S4

DET.	QTY	PART NO.	DESCRIPTION	DET.	QTY	PART NO.	DESCRIPTION
1	2	621518	HYD CYL, 2.50 X 14.00 X 1.250	17	4	615684	HYD TUBE ASSY, BOOM EXT FOLD96
2	2	621520	HYD CYL, 2.00 X 10.00 X 1.000	18	13	618119	9/16MJIC-90-9/16MOR LBO
3	1	606455	NORAC HYD VALVE (44963D)	19	2	618688	9/16MJ-90-9/16MOR .025 CHK VLV
4	4	618185	3/8MNPT-1/4FNPSM SWIV ADPTR	20	6	618733	9/16JIC .042 ORIFICE ADPTR
5	2	621522	HYD CYL, 2.00 X 10.00 X 1.000	21	1	616028	04-482TC-06FJX-06FJX-47
6	2	618689	9/16MJ-90-9/16MOR .042 CHK VLV	22	1	614714	04-482TC-06FJX-06FJX-34
7	2	618115	9/16MJIC-90-3/4MOR LBO	23	1	616049	04-482TC-06FJX-06FJX-26
8	2	621526	HYD CYL, 2.50 X 16.94 X 1.250	24	5	615442	04-482TC-06FJX-06FJX-55
9	1	615761	LIFT RAISE HYD TUBE ASSY	25	1	618618	9/16MJIC-90-9/16FJIC SWIV LBO
10	1	615762	LIFT LOWER HYD TUBE ASSY	26	2	616174	04-482TC-06FJX-06FJX-70
11	2	615813	LEVEL HYD TUBE ASSY	27	6	616040	04-482TC-06FJX-06FJX-67
12	5	618126	9/16MJIC-9/16MOR ADPTR	28	18	619010	9/16MJIC UNION
13	1	615766	BOOM EXTN RAISE HYD TUBE ASSY	29	1	614713	04-482TC-06FJX-06FJX-24
14	1	615767	BOOM EXTN LOWER HYD TUBE ASSY	30	2	614033	04-482TC-06FJX-06FJX-17
15	1	615768	RH FOLD RAISE HYD TUBE ASSY	31	1	614715	04-482TC-06FJX-06FJX-43
16	1	615769	RH FOLD LOWER HYD TUBE ASSY	32	4	616043	04-482TC-06FJX-06FJX-23

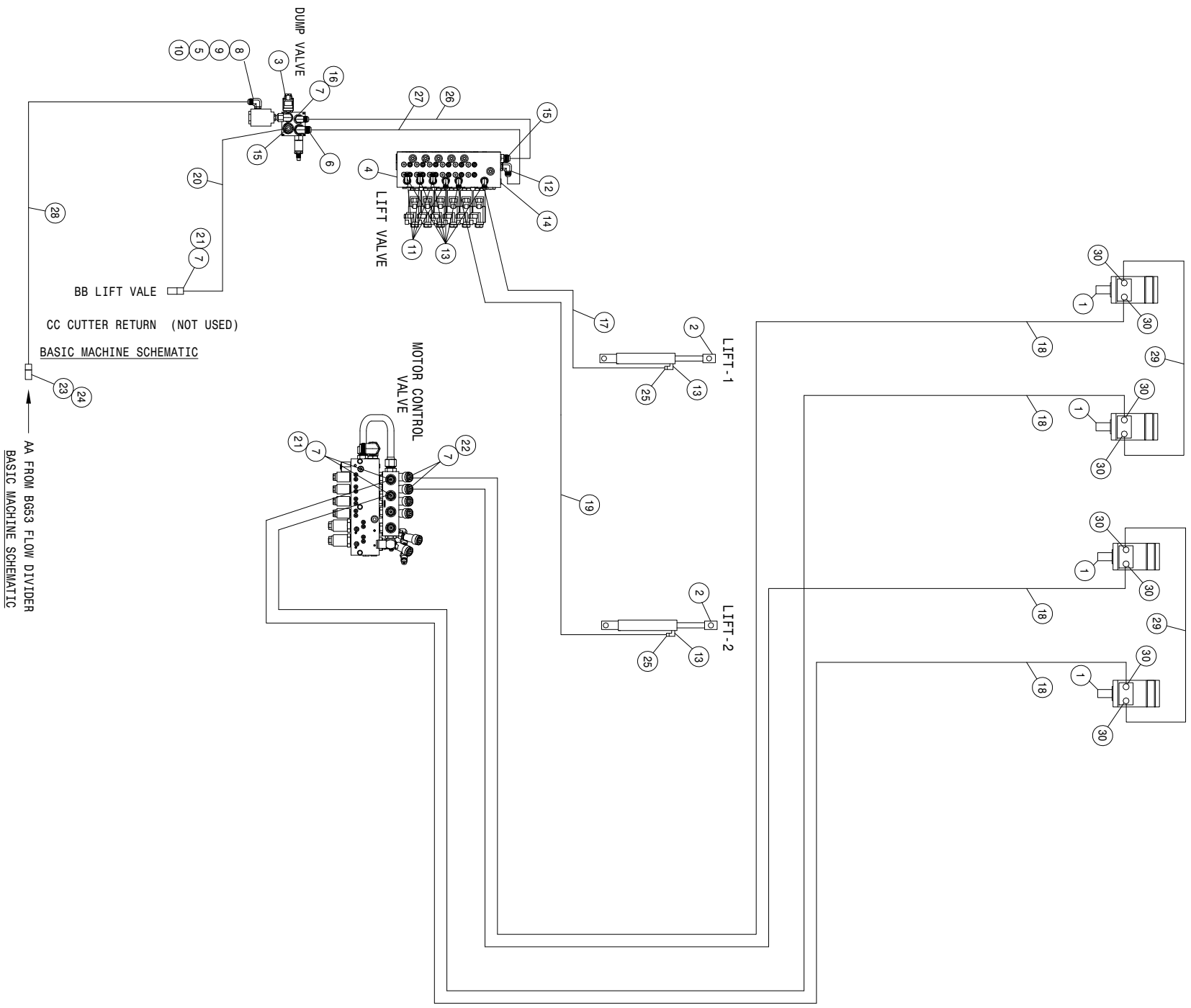

DTS10C 4R QUAD 2L LS HYD SCHEM 2010
REFERENCE DRAWING NO. 499202

DET.	QTY	PART NO.	DESCRIPTION	DET.	QTY	PART NO.	DESCRIPTION
1	4	610547	HYD MOTOR 4.5CI 1IN SHFT	16	1	618609	3/4MJIC-90-3/4FJIC SWIV LBO
2	2	621564	HYD CYL,2.00 X 11.00 X 1.50 1W	17	1	615729	04-482TC-06FJX-06FJX-84
3	1	606330	DUMP MANIF VALVE SAUER	18	4	616168	08-482TC-08FJX-08FJX-139
4	1	606285	LIFT VALVE,STS COMBO,SAUER	19	1	614101	04-482TC-06FJX-06FJX-133
5	1	605615	HYD FILTER,INLINE 25M 9/16FOR	20	1	616006	08-482TC-08FJX-10FJX-33
6	1	611128	7/8MJIC-90-7/8MOR LBO	21	3	618696	HYD COUPLER,FEM 1/2B, 3/4FOR
7	6	611125	3/4MJIC-3/4MOR ADPTR	22	2	618697	HYD COUPLER,MALE 1/2B, 3/4FOR
8	1	618464	3/4MJIC-90-3/4MOR LG LBO	23	1	618011	9/16MJIC-3/8MNP ADPTR
9	1	618692	3/4FJIC SWIV-9/16MOR ADPTR	24	1	618646	HYD QUICK CPLR, MALE .375NPS
10	1	618249	3/4MJIC-90-9/16MOR LBO	25	2	618733	9/16JIC .042 ORIFICE ADPTR
11	4	618531	9/16FJIC CAP NUT	26	1	616938	06C1T-08FJX-06FJX90-25
12	1	618241	3/4MJIC-90-3/4MOR LBO	27	1	616939	08C1T-08FJX-10FJX-27
13	8	618119	9/16MJIC-90-9/16MOR LBO	28	1	616937	06-482TC-06FJX-08FJX-27
14	1	618754	9/16MOR PLUG, HEX SOCKET	29	2	616025	08-482TC-08FJX-08FJX-50
15	2	611126	7/8MJIC-7/8MOR ADPTR	30	8	618327	3/4MJIC-7/8MOR ADPTR

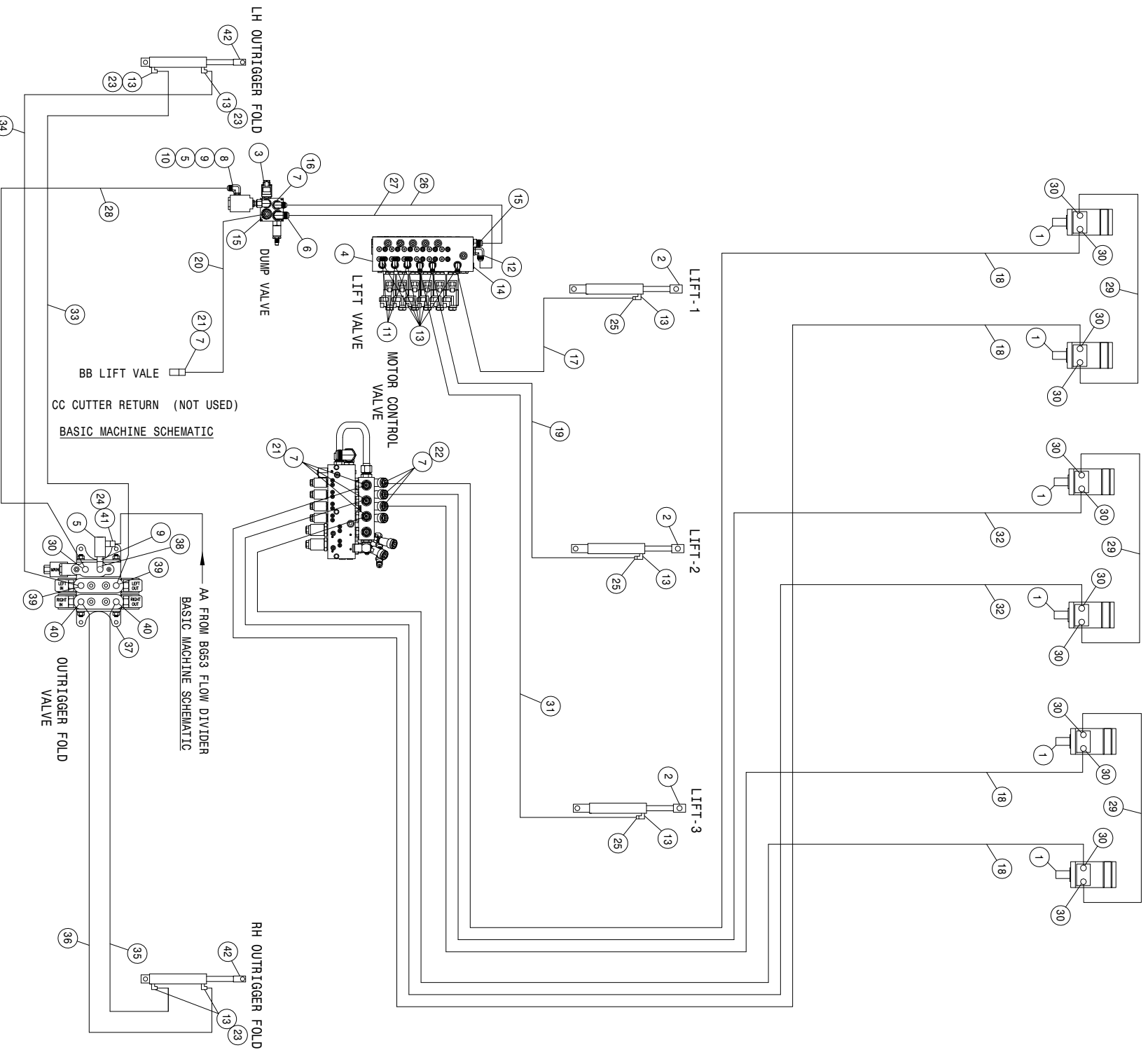

DTS10C 6R QUAD 3L LS HYD SCHEM 2010
REFERENCE DRAWING NO. 499203

DET.	QTY	PART NO.	DESCRIPTION	DET.	QTY	PART NO.	DESCRIPTION
1	6	610547	HYD MOTOR 4.5CI 1IN SHFT	22	3	618697	HYD COUPLER, MALE 1/2B, 3/4FOR
2	3	621564	HYD CYL, 2.00 X 11.00 X 1.50 1W	23	4	618731	9/16JIC .025 ORIFICE ADPTR
3	1	606330	DUMP MANIF VALVE	24	1	618646	HYD QUICK CPLR, MALE .375NPS
4	1	606285	LIFT VALVE, STS COMBO, SAUER	25	3	618733	9/16JIC .042 ORIFICE ADPTR
5	2	605615	HYD FILTER, INLINE 25M 9/16FOR	26	1	616938	06CIT-08FJX-06FJX90-25
6	1	611128	7/8MJIC-90-7/8MOR LBO	27	1	616939	08CIT-08FJX-10FJX-27
7	8	611125	3/4MJIC-3/4MOR ADPTR	28	1	616937	06-482TC-06FJX-08FJX-27
8	1	618464	3/4MJIC-90-3/4MOR LG LBO	29	3	616025	08-482TC-08FJX-08FJX-50
9	2	618692	3/4FJIC SWIV-9/16MOR ADPTR	30	13	618327	3/4MJIC-7/8MOR ADPTR
10	1	618249	3/4MJIC-90-9/16MOR LBO	31	1	611210	04-482TC-06FJX-06FJX-156
11	3	618531	9/16FJIC CAP NUT	32	2	614689	08-482TC-08FJX-08FJX-120
12	1	618241	3/4MJIC-90-3/4MOR LBO	33	1	615616	04-482TC-06FJX-06FJX-65
13	13	618119	9/16MJIC-90-9/16MOR LBO	34	1	615314	04-482TC-06FJX-06FJX-50
14	1	618754	9/16MOR PLUG, HEX SOCKET	35	1	616636	04-482TC-06FJX-06FJX-143
15	2	611126	7/8MJIC-7/8MOR ADPTR	36	1	616191	04-482TC-06FJX-06FJX-138
16	1	618609	3/4MJIC-90-3/4FJIC SWIV LBO	37	1	606090	BRAND HYD VALVE, 2-SECT SER 36
17	1	614308	04-482TC-06FJX-06FJX-109	38	1	618183	3/4MJIC-90-7/8MOR LBO
18	4	614690	08-482TC-08FJX-08FJX-192	39	2	618115	9/16MJIC-90-3/4MOR LBO
19	1	614152	04-482TC-06FJX-06FJX-114	40	2	618709	9/16MJIC-90-3/4MOR EX LG LBO
20	1	616006	08-482TC-08FJX-10FJX-33	41	1	618345	9/16MOR-3/8MNPT ADPTR
21	4	618696	HYD COUPLER, FEM 1/2B, 3/4FOR	42	2	621520	HYD CYL, 2.00 X 10.00 X 1.000

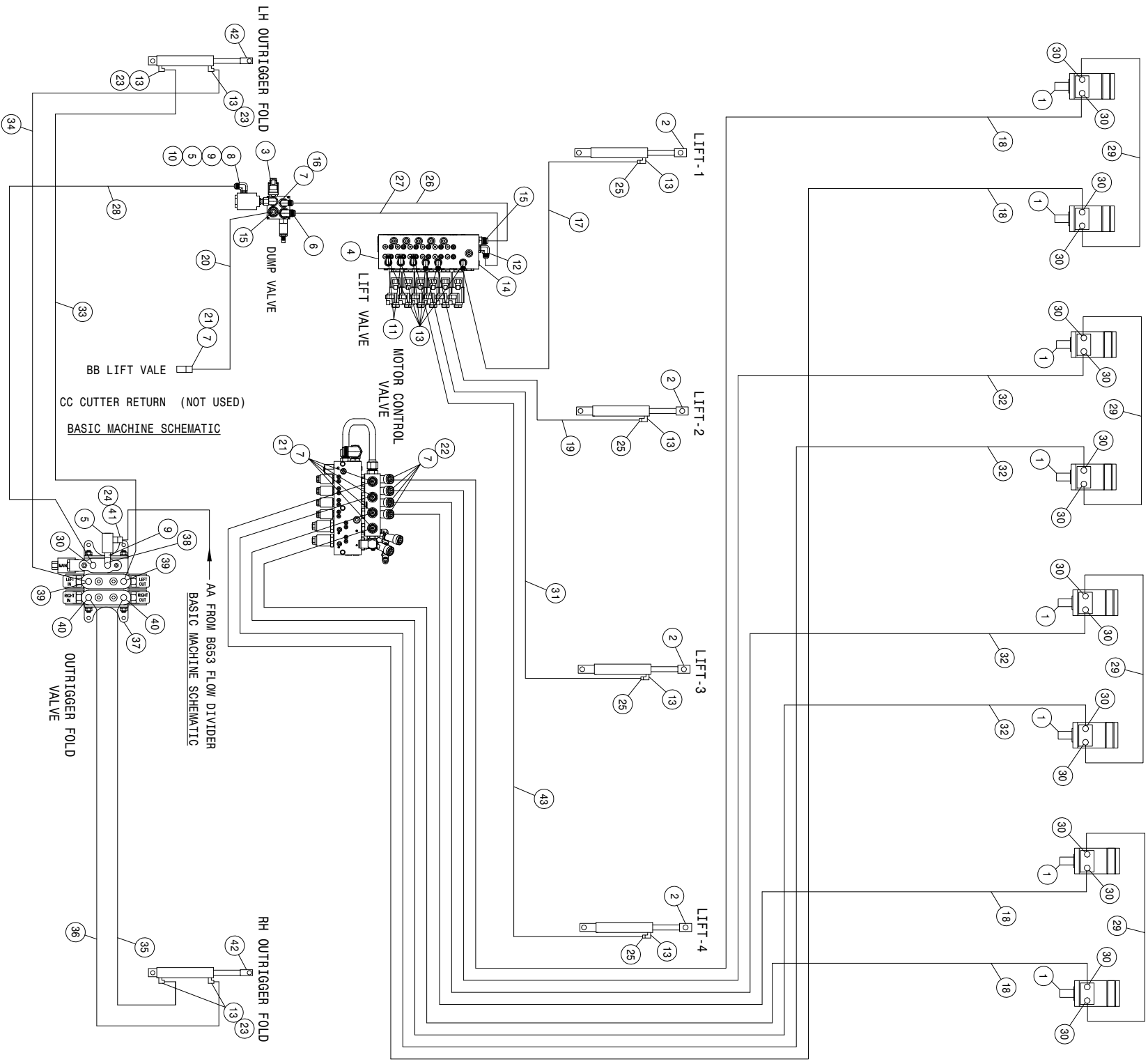

DTS10C 8R QUAD 4L LS HYD SCHEM 2010
REFERENCE DRAWING NO. 499204

DET.	QTY	PART NO.	DESCRIPTION	DET.	QTY	PART NO.	DESCRIPTION
1	8	610547	HYD MOTOR 4.5CI 1IN SHFT	23	4	618731	9/16JIC .025 ORIFICE ADPTR
2	4	621564	HYD CYL,2.00 X 11.00 X 1.50 1W	24	1	618646	HYD QUICK CPLR, MALE .375NPS
3	1	606330	DUMP MANIF VALVE SAUER	25	4	618733	9/16JIC .042 ORIFICE ADPTR
4	1	606285	LIFT VALVE,STS COMBO,SAUER	26	1	616938	06C1T-.08FJX-.06FJX90-.25
5	2	605615	HYD FILTER,INLINE 25M 9/16FOR	27	1	616939	08C1T-.08FJX-.10FJX-.27
6	1	611128	7/8MJIC-90-7/8MOR LBO	28	1	616937	06-482TC-.06FJX-.08FJX-.27
7	10	611125	3/4MJIC-3/4MOR ADPTR	29	4	616025	08-482TC-.08FJX-.08FJX-.50
8	2	618464	3/4MJIC-90-3/4MOR LG LBO	30	17	618327	3/4MJIC-.7/8MOR ADPTR
9	1	618692	3/4FJIC SMIV-9/16MOR ADPTR	31	1	614308	04-482TC-.06FJX-.06FJX-.109
10	1	618249	3/4MJIC-90-9/16MOR LBO	32	4	616168	08-482TC-.08FJX-.08FJX-.139
11	2	618531	9/16FJIC CAP NUT	33	1	615616	04-482TC-.06FJX-.06FJX-.65
12	1	618241	3/4MJIC-90-3/4MOR LBO	34	1	615314	04-482TC-.06FJX-.06FJX-.50
13	14	618119	9/16MJIC-90-9/16MOR LBO	35	1	616636	04-482TC-.06FJX-.06FJX-.143
14	1	618754	7/8MJIC-7/8MOR ADPTR	36	1	616191	04-482TC-.06FJX-.06FJX-.138
15	2	611126	3/4MJIC-90-3/4FJIC SMIV LBO	37	1	606090	BRAND HYD VALVE, 2-SECT SER 36
16	1	618609	04-482TC-.06FJX-.06FJX-.156	38	1	618183	3/4MJIC-90-7/8MOR LBO
17	1	611210	08-482TC-.08FJX-.08FJX-.237	39	2	618115	9/16MJIC-90-3/4MOR LBO
18	4	614384	04-482TC-.06FJX-.06FJX-.84	40	2	618709	9/16MJIC-90-3/4MOR EX LG LBO
19	1	615729	08-482TC-.08FJX-.10FJX-.33	41	1	618345	9/16MOR-3/8MNPT ADPTR
20	1	616006	HYD COUPLER,FEM 1/2B, 3/4FOR	42	2	621520	HYD CYL, 2.00 X 10.00 X 1.000
21	5	618696	HYD COUPLER,MALE 1/2B, 3/4FOR	43	1	616419	04-482TC-.06FJX-.06FJX-.204
22	4	618697					

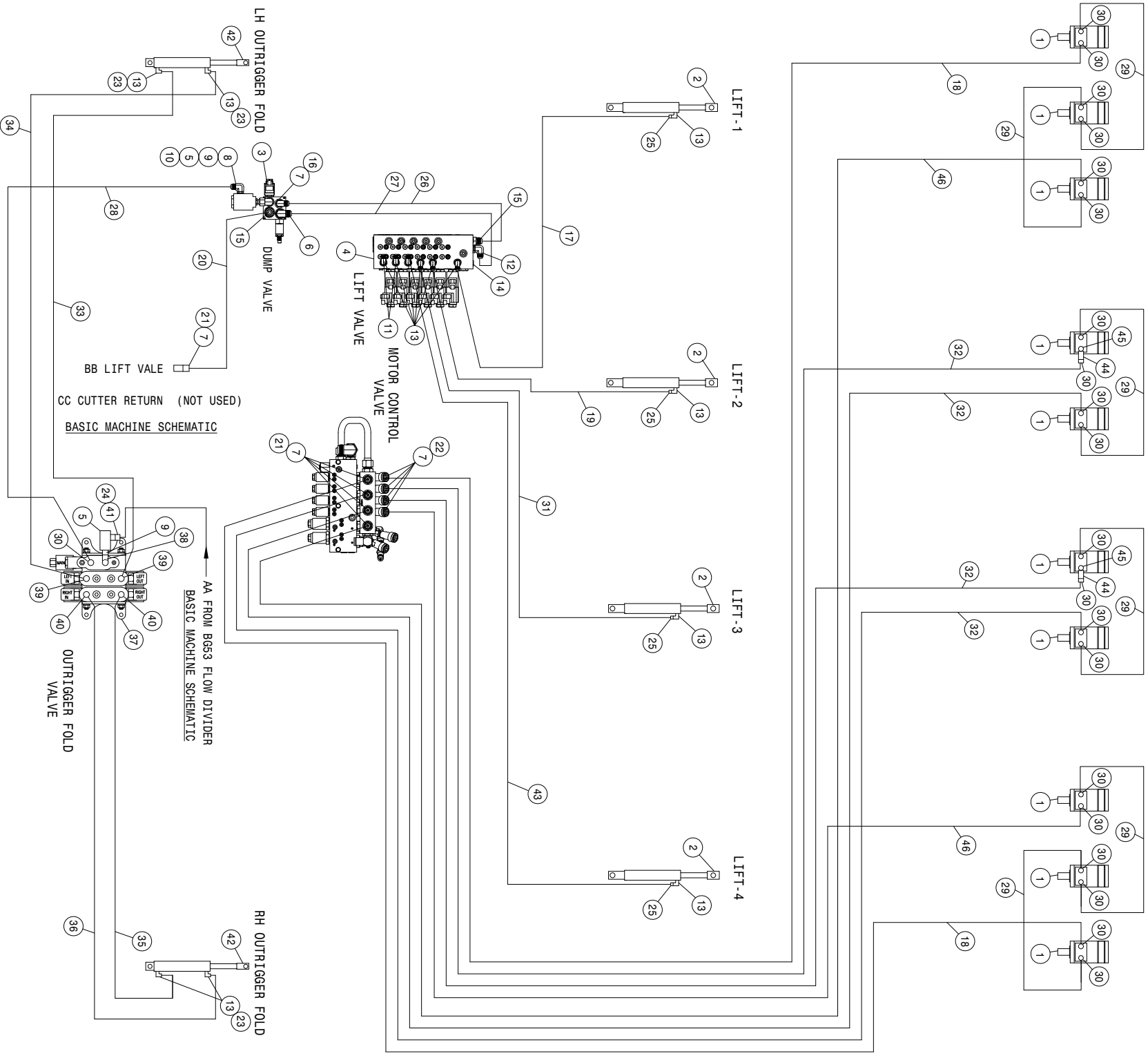

DTS10C 10R QUAD 4L LS HYD SCHEM 2010
REFERENCE DRAWING NO. 499205

DET.	QTY	PART NO.	DESCRIPTION	DET.	QTY	PART NO.	DESCRIPTION
1	10	610547	HYD MOTOR 4.5CI 1IN SHFT	24	1	618646	HYD QUICK CPLR, MALE .375NPS
2	4	621564	HYD CYL, 2.00 X 11.00 X 1.50 1W	25	4	618733	9/16JIC .042 ORIFICE ADPTR
3	1	606330	DUMP MANIF VALVE	26	1	616938	06C1T-08FJX-06FJX90-25
4	1	606285	LIFT VALVE, STS COMBO, SAUER	27	1	616939	08C1T-08FJX-10FJX-27
5	2	605615	HYD FILTER, INLINE 25M 9/16FOR	28	1	616937	06-4822TC-06FJX-08FJX-27
6	1	611128	7/8MJIC-90-7/8MOR LBO	29	6	616025	08-4822TC-08FJX-08FJX-50
7	10	611125	3/4MJIC-3/4MOR ADPTR	30	21	618327	3/4MJIC-7/8MOR ADPTR
8	1	618464	3/4MJIC-90-3/4MOR LG LBO	31	1	614152	04-4822TC-06FJX-06FJX-114
9	2	618692	3/4FJIC SWIV-9/16MOR ADPTR	32	4	616168	08-4822TC-08FJX-08FJX-139
10	1	618249	3/4MJIC-90-9/16MOR LBO	33	1	615616	04-4822TC-06FJX-06FJX-65
11	2	618531	9/16FJIC CAP NUT	34	1	615314	04-4822TC-06FJX-06FJX-50
12	1	618241	3/4MJIC-90-3/4MOR LBO	35	1	616636	04-4822TC-06FJX-06FJX-143
13	14	618119	9/16MJIC-90-9/16MOR LBO	36	1	616191	04-4822TC-06FJX-06FJX-138
14	1	618754	9/16MOR PLUG, HEX SOCKET	37	1	606090	BRAND HYD VALVE, 2-SECT SER 36
15	2	611126	7/8MJIC-7/8MOR ADPTR	38	1	618183	3/4MJIC-90-7/8MOR LBO
16	1	618609	3/4MJIC-90-3/4FJIC SWIV LBO	39	2	618115	9/16MJIC-90-3/4MOR LBO
17	1	611246	04-4822TC-06FJX-06FJX-174	40	2	618709	9/16MJIC-90-3/4MOR EX LG LBO
18	2	614387	08-4822TC-08FJX-08FJX-267	41	1	618345	9/16MOR-3/8MNPT ADPTR
19	1	615729	04-4822TC-06FJX-06FJX-84	42	2	621520	HYD CYL, 2.00 X 10.00 X 1.000
20	1	616006	08-4822TC-08FJX-10FJX-33	43	1	616421	04-4822TC-06FJX-06FJX-228
21	5	618696	HYD COUPLER, FEM 1/2B, 3/4FOR	44	2	607522	FLOW REGULATOR, 8GPM VONBERG
22	4	618697	HYD COUPLER, MALE 1/2B, 3/4FOR	45	2	618586	7/8MOR UNION
23	4	618731	9/16JIC .025 ORIFICE ADPTR	46	2	614384	08-4822TC-08FJX-08FJX-237

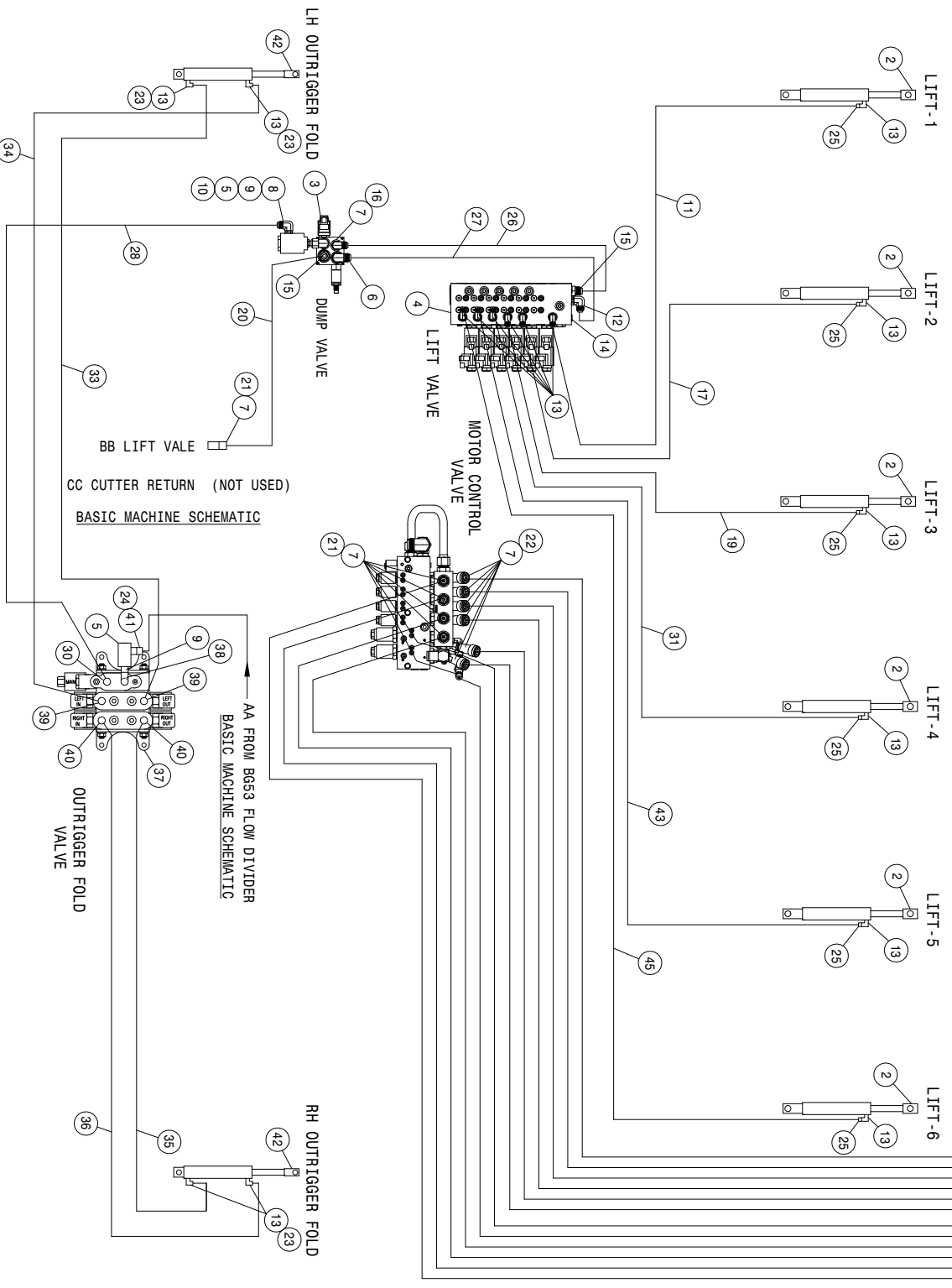
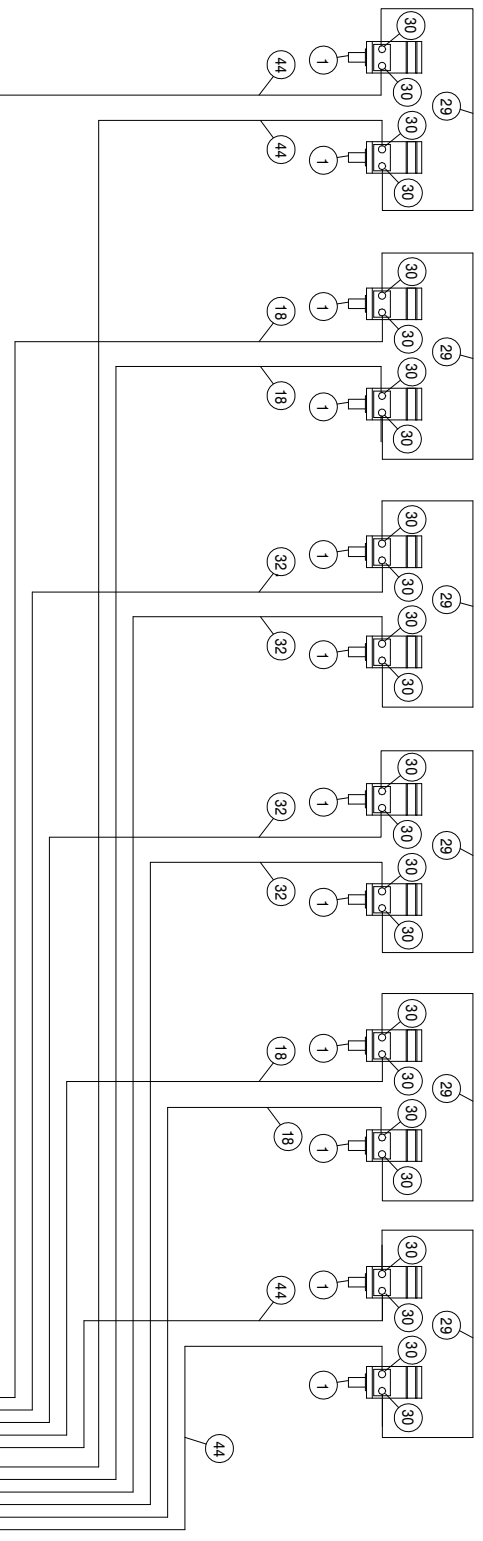

DTS10C 12R QUAD 6L LS HYD SCHEM 2010
REFERENCE DRAWING NO. 4992206

DET.	QTY	PART NO.	DESCRIPTION	DET.	QTY	PART NO.	DESCRIPTION
1	12	610547	HYD MOTOR 4.5CI 1IN SHFT	24	1	618646	HYD QUICK CPLR, MALE .375NPS
2	6	621564	HYD CYL,2.00 X 11.00 X 1.50 1W	25	6	618733	9/16JIC .042 ORIFICE ADPTR
3	1	606330	DUMP MANIF VALVE	26	1	616938	06C1T-08FJX-06FJX90-25
4	1	606285	LIFT VALVE,STS COMBO,SAUER	27	1	616939	08C1T-08FJX-10FJX-27
5	2	605615	HYD FILTER,INLINE 25M 9/16FOR	28	1	616937	06-482TC-06FJX-08FJX-27
6	1	611128	7/8MJIC-90-7/8MOR LBO	29	6	616025	08-482TC-08FJX-08FJX-50
7	14	611125	3/4MJIC-3/4MOR ADPTR	30	25	618327	3/4MJIC-7/8MOR ADPTR
8	1	618464	3/4MJIC-90-3/4MOR LG LBO	31	1	614308	04-482TC-06FJX-06FJX-109
9	2	618692	3/4FJIC SWIV-9/16MOR ADPTR	32	4	616168	08-482TC-08FJX-08FJX-139
10	1	618249	3/4MJIC-90-9/16MOR LBO	33	1	615616	04-482TC-06FJX-06FJX-65
11	1	614303	04-482TC-06FJX-06FJX-234	34	1	615314	04-482TC-06FJX-06FJX-50
12	1	618241	3/4MJIC-90-3/4MOR LBO	35	1	616636	04-482TC-06FJX-06FJX-143
13	16	618119	9/16MJIC-90-9/16MOR LBO	36	1	616191	04-482TC-06FJX-06FJX-138
14	1	618754	9/16MOR PLUG, HEX SOCKET	37	1	606090	BRAND HYD VALVE, 2-SECT SER 36
15	2	611126	7/8MJIC-7/8MOR ADPTR	38	1	618183	3/4MJIC-90-7/8MOR LBO
16	1	618609	3/4MJIC-90-3/4FJIC SWIV LBO	39	2	618115	9/16MJIC-90-3/4MOR LBO
17	1	611210	04-482TC-06FJX-06FJX-156	40	2	618709	9/16MJIC-90-3/4MOR EX LG LBO
18	4	614384	08-482TC-08FJX-08FJX-237	41	1	618345	9/16MOR-3/8MNP ADPTR
19	1	615729	04-482TC-06FJX-06FJX-84	42	2	621520	HYD CYL, 2.00 X 10.00 X 1.000
20	1	616006	08-482TC-08FJX-10FJX-33	43	1	616419	04-482TC-06FJX-06FJX-204
21	7	618696	HYD COUPLER,FEM 1/2B, 3/4FOR	44	4	616170	08-482TC-08FJX-08FJX-295
22	6	618697	HYD COUPLER,MALE 1/2B, 3/4FOR	45	1	615731	04-482TC-06FJX-06FJX-290
23	4	618731	9/16JIC .025 ORIFICE ADPTR				

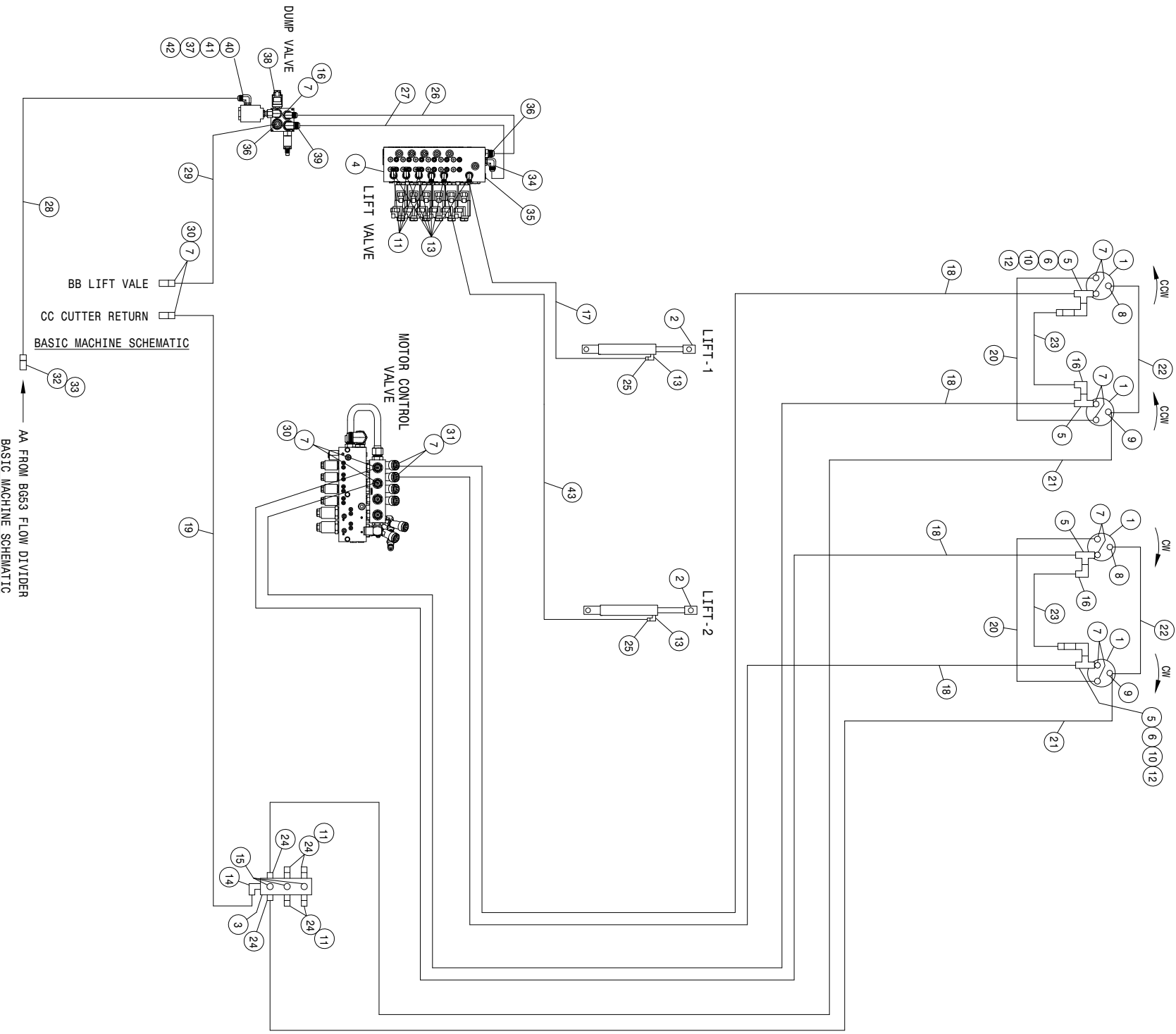

DTS10C 4R CUTTER 2L LS HYD SCHEM 2010
REFERENCE DRAWING NO. 499208

DET.	QTY	PART NO.	DESCRIPTION	DET.	QTY	PART NO.	DESCRIPTION
1	4	610755	BARNES HYD MOTOR, D-SERIES 01	23	2	616025	08-482TC-08FJX-08FJX-50 H/A
2	2	621564	HYD CYL, 2.00 X 11.00 X 1.50 1W	24	6	618109	9/16MJIC-3/4MOR ADPTR
3	1	606021	HYD RETURN MANIF. 3/4FOR, 9-PORT	25	2	618733	9/16JIC .042 ORIFICE ADPTR
4	1	606285	LIFT VALVE, STS COMBO, SAUER	26	1	616938	06C1T-08FJX-06FJX90-.25 H/A
5	4	618451	3/4FJIC SW RUN TEE-3/4MJIC	27	1	616939	08C1T-08FJX-10FJX-27 H/A
6	2	618620	3/4FJX-90-1/2MNPT ADPTR	28	1	616937	06-482TC-06FJX-08FJX-27 H/A
7	15	611125	3/4MJIC-3/4MOR ADPTR	29	1	616006	08-482TC-08FJX-10FJX-33 H/A
8	2	618530	9/16MJIC-1/8MNPT ADPTR	30	4	618696	HYD COUPLER, FEM 1/2B, 3/4FOR
9	2	618546	1/8MNPT RUN TEE-9/16MJIC	31	2	618697	HYD COUPLER, MALE 1/2B, 3/4FOR
10	2	690338	LINE CHECK VALVE HYD .50NPT	32	1	618011	9/16MJIC-3/8MNPT ADPTR
11	8	618531	9/16FJIC CAP NUT	33	1	618646	HYD QUICK CPLR, MALE .375NPS
12	2	611147	3/4MJIC-1/2MNPT ADPTR	34	1	618241	3/4MJIC-90-3/4MOR LBO
13	8	618119	9/16MJIC-90-9/16MOR LBO	35	1	618754	9/16MOR PLUG, HEX SOCKET
14	1	618474	3/4MJIC-90-1 1/16MOR LBO	36	2	611126	7/8MJIC-7/8MOR ADPTR
15	3	611159	3/4MOR PLUG, HEX HEAD	37	1	605615	HYD FILTER, INLINE 25M 9/16FOR
16	3	618609	3/4MJIC-90-3/4FJIC SWIV LBO	38	1	606330	DUMP MANIF VALVE SAUER
17	1	615729	04-482TC-06FJX-06FJX-84 H/A	39	1	611128	7/8MJIC-90-7/8MOR LBO
18	4	616168	08-482TC-08FJX-08FJX-139 H/A	40	1	618464	3/4MJIC-90-3/4MOR LG LBO
19	1	616135	08-451TC-08FJX-08FJX-50 H/A	41	1	618692	3/4FJIC SWIV-9/16MOR ADPTR
20	2	614368	08-482TC-08FJX-08FJX-60 H/A	42	1	618249	3/4MJIC-90-9/16MOR LBO
21	2	611202	04-482TC-06FJX-06FJX-136 H/A	43	1	614101	04-482TC-06FJX-06FJX-133 H/A
22	2	616422	04-482TC-06FJX-06FJX90-.50 H/A				

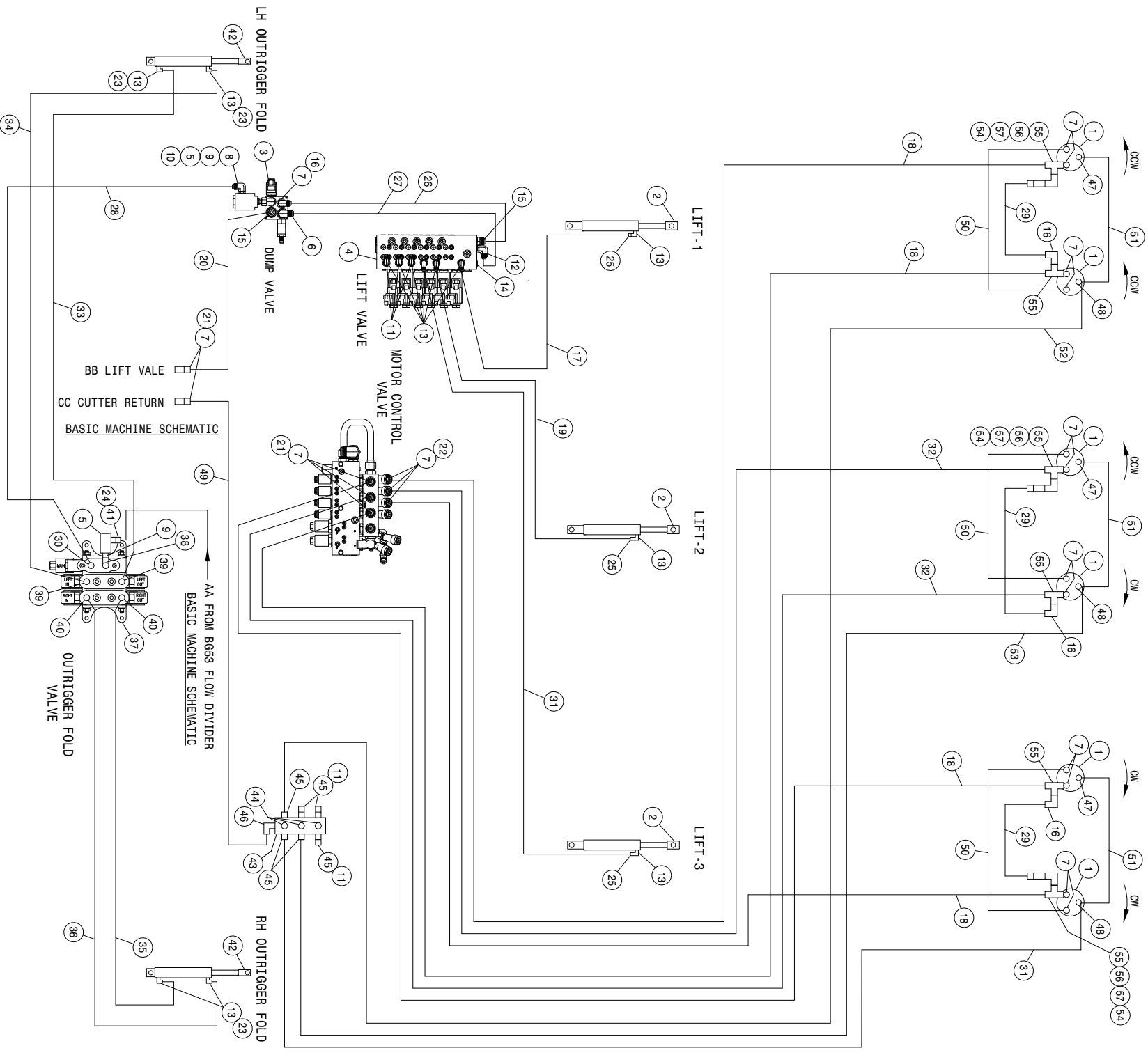

DTS10C 6R CUTR 3L LS HYD SCHEM 2010
REFERENCE DRAWING NO. 499209

DET.	QTY	PART NO.	DESCRIPTION	DET.	QTY	PART NO.	DESCRIPTION
1	6	610755	BARNES HYD MOTOR, D-SERIES 01	30	1	618327	3/4MJIC-7/8MOR ADPTR
2	3	621564	HYD CYL,2.00 X 11.00 X 1.50 1W	31	2	611210	04-482TC-06FJX-06FJX-156
3	1	606330	DUMP MANIF VALVE SAUER	32	2	614689	08-482TC-08FJX-08FJX-120
4	1	606285	LIFT VALVE,STS COMBO,SAUER	33	1	615616	04-482TC-06FJX-06FJX-65
5	2	605615	HYD FILTER, INLINE 25M 9/16FOR	34	1	615314	04-482TC-06FJX-06FJX-50
6	1	611128	7/8MJIC-90-7/8MOR LBO	35	1	616636	04-482TC-06FJX-06FJX-143
7	21	611125	3/4MJIC-3/4MOR ADPTR	36	1	616191	04-482TC-06FJX-06FJX-138
8	1	618464	3/4MJIC-90-3/4MOR LG LBO	37	1	606090	BRAND HYD VALVE, 2-SECT SER 36
9	2	618692	3/4FJIC SMIV-9/16MOR ADPTR	38	1	618183	3/4MJIC-90-7/8MOR LBO
10	1	618249	3/4MJIC-90-9/16MOR LBO	39	2	618115	9/16MJIC-90-3/4MOR LBO
11	6	618531	9/16FJIC CAP NUT	40	2	618709	9/16MJIC-90-3/4MOR EX LG LBO
12	1	618241	3/4MJIC-90-3/4MOR LBO	41	1	618345	9/16MOR-3/8MNPT ADPTR
13	13	618119	9/16MJIC-90-9/16MOR LBO	42	2	621520	HYD CYL, 2.00 X 10.00 X 1.000
14	1	618754	9/16MOR PLUG, HEX SOCKET	43	1	606021	HYD RETURN MANIF, 3/4FOR, 9-PORT
15	2	611126	7/8MJIC-7/8MOR ADPTR	44	3	611159	3/4MOR PLUG, HEX HEAD
16	4	618609	3/4MJIC-90-3/4FJIC SMIV LBO	45	6	618109	9/16MJIC-3/4MOR ADPTR
17	1	614308	04-482TC-06FJX-06FJX-109	46	1	618474	3/4MJIC-90-1 1/16MOR LBO
18	4	614690	08-482TC-08FJX-08FJX-192	47	3	618530	9/16MJIC-1/8MNPT ADPTR
19	1	614152	04-482TC-06FJX-06FJX-114	48	3	618546	1/8MNPT RUN TEE-9/16MJIC
20	1	616006	08-482TC-08FJX-10FJX-35	49	3	616135	08-451TC-08FJX-08FJX-50
21	5	618696	HYD COUPLER, FEM 1/2B, 3/4FOR	50	3	614368	08-482TC-08FJX-08FJX-60
22	3	618697	HYD COUPLER, MALE 1/2B, 3/4FOR	51	3	616422	04-482TC-06FJX-06FJX90-50
23	4	618731	9/16JIC .025 ORIFICE ADPTR	52	1	614102	04-482TC-06FJX-06FJX-191
24	1	618646	HYD QUICK CPLR, MALE .375NPS	53	1	614101	04-482TC-06FJX-06FJX-133
25	3	618733	9/16JIC .042 ORIFICE ADPTR	54	3	611147	3/4MJIC-1/2MNPT ADPTR
26	1	616938	06C1T-08FJX-06FJX90-25	55	6	618451	3/4FJIC SW RUN TEE-3/4MJIC
27	1	616939	08C1T-08FJX-10FJX-27	56	3	618620	3/4FJX-90-1/2MNPT ADPTR
28	1	616937	06-482TC-06FJX-08FJX-27	57	3	690338	LINE CHECK VALVE HYD .50NPT
29	3	616025	08-482TC-08FJX-08FJX-50				

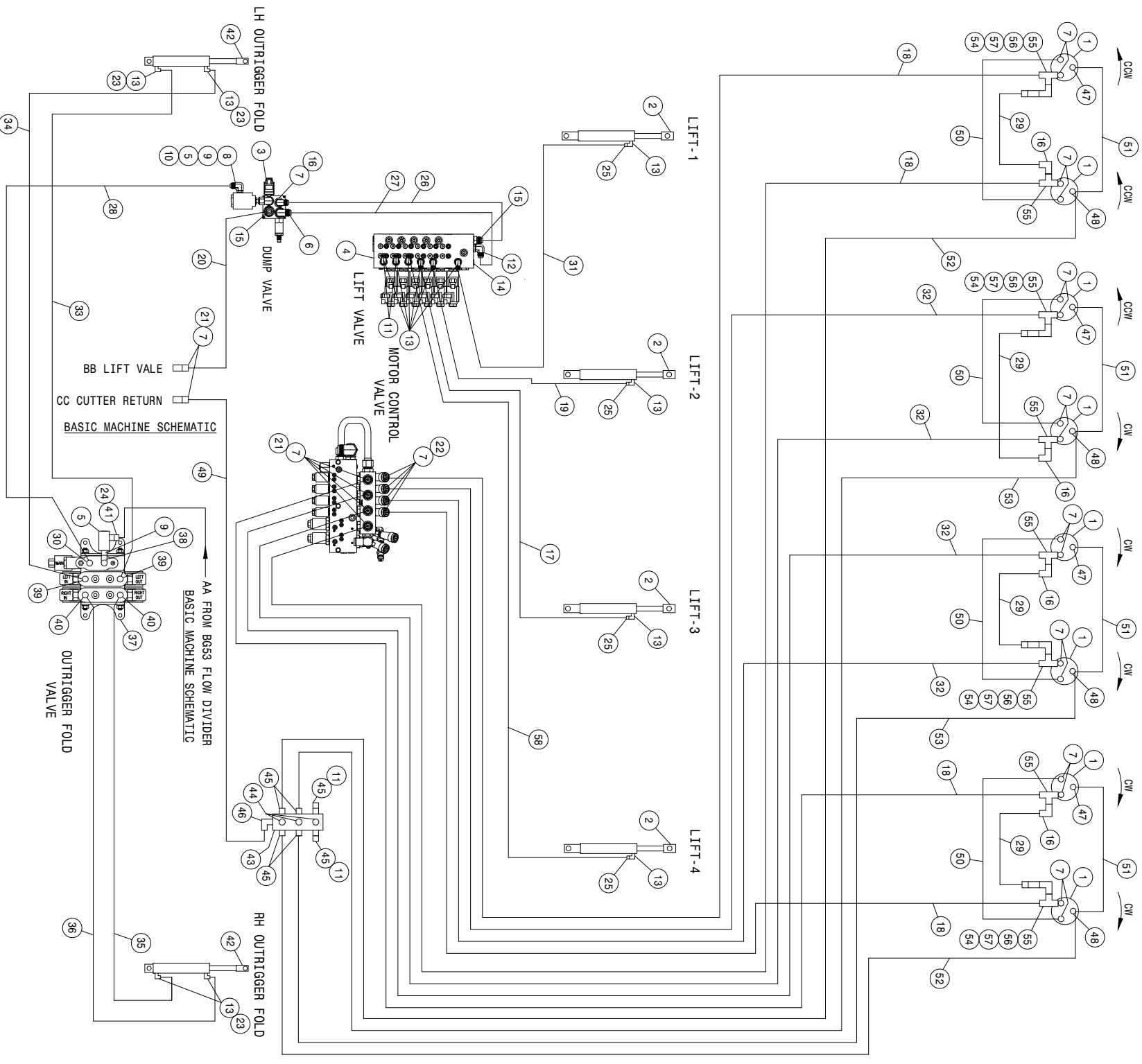

DTS10C 8R CUTR 4L LS HYD SCHEM 2010
REFERENCE DRAWING NO. 499210

DET.	QTY	PART NO.	DESCRIPTION	DET.	QTY	PART NO.	DESCRIPTION
1	8	610755	BARNES HYD MOTOR, D-SERIES 01	30	1	618327	3/4MJIC-7/8MOR ADPTR
2	4	621564	HYD CYL,2.00 X 11.00 X 1.50 1W	31	1	611210	04-482TC-06FJX-06FJX-156
3	1	606330	DUMP MANIF VALVE SAUER	32	2	616168	08-482TC-08FJX-08FJX-139
4	1	606285	LIFT VALVE,STS COMBO,SAUER	33	1	615616	04-482TC-06FJX-06FJX-65
5	2	605615	HYD FILTER,INLINE 25M 9/16FOR	34	1	615314	04-482TC-06FJX-06FJX-50
6	1	611128	7/8MJIC-90-7/8MOR LBO	35	1	616636	04-482TC-06FJX-06FJX-143
7	27	611125	3/4MJIC-90-3/4MOR ADPTR	36	1	616191	04-482TC-06FJX-06FJX-138
8	1	618464	3/4MJIC-90-3/4MOR LG LBO	37	1	606090	BRAND HYD VALVE, 2-SECT SER 36
9	2	618692	3/4FJIC SMIV-9/16MOR ADPTR	38	1	618183	3/4MJIC-90-7/8MOR LBO
10	1	618249	3/4MJIC-90-9/16MOR ADPTR	39	2	618115	9/16MJIC-90-3/4MOR LBO
11	4	618531	9/16FJIC CAP NUT	40	2	618709	9/16MJIC-90-3/4MOR EX LG LBO
12	1	618241	3/4MJIC-90-3/4MOR LBO	41	1	618345	9/16MJIC-90-3/4MOR EX LG LBO
13	14	618119	9/16MJIC-90-9/16MOR LBO	42	2	621520	HYD CYL, 2.00 X 10.00 X 1.000
14	1	618754	9/16MOR PLUG, HEX SOCKET	43	1	606021	HYD RETURN MANIF,3/4FOR,9-PORT
15	2	611126	7/8MJIC-7/8MOR ADPTR	44	3	611159	3/4MOR PLUG, HEX HEAD
16	5	618609	3/4MJIC-90-3/4FJIC SMIV LBO	45	6	618109	9/16MJIC-3/4MOR ADPTR
17	1	614308	04-482TC-06FJX-06FJX-109	46	1	618474	3/4MJIC-90-1 1/16MOR LBO
18	4	614384	08-482TC-08FJX-08FJX-237	47	4	618530	9/16MJIC-1/8MNPT ADPTR
19	1	615729	04-482TC-06FJX-06FJX-84	48	4	618546	1/8MNPT RUN TEE-9/16MJIC
20	1	616006	08-482TC-08FJX-10FJX-33	49	1	616135	08-451TC-08FJX-08FJX-50
21	7	618696	HYD COUPLER,FEM 1/2B, 3/4FOR	50	4	614368	08-482TC-08FJX-08FJX-60
22	4	618697	HYD COUPLER,MALE 1/2B, 3/4FOR	51	4	616422	04-482TC-06FJX-06FJX90-50
23	4	618731	9/16JIC .025 ORIFICE ADPTR	52	2	614303	04-482TC-06FJX-06FJX-234
24	1	618646	HYD QUICK CPLR, MALE .375NPS	53	2	611202	04-482TC-06FJX-06FJX-136
25	4	618733	9/16JIC .042 ORIFICE ADPTR	54	4	611147	3/4MJIC-1/2MNPT ADPTR
26	1	616938	06C1T-08FJX-06FJX90-25	55	8	618451	3/4FJIC SW RUN TEE-3/4MJIC
27	1	616939	08C1T-08FJX-10FJX-27	56	4	618620	3/4FJIC-90-1/2MNPT ADPTR
28	1	616937	06-482TC-06FJX-08FJX-27	57	4	690338	LINE CHECK VALVE HYD .50NPT
29	4	616025	08-482TC-08FJX-08FJX-50	58	1	616419	04-482TC-06FJX-06FJX-204

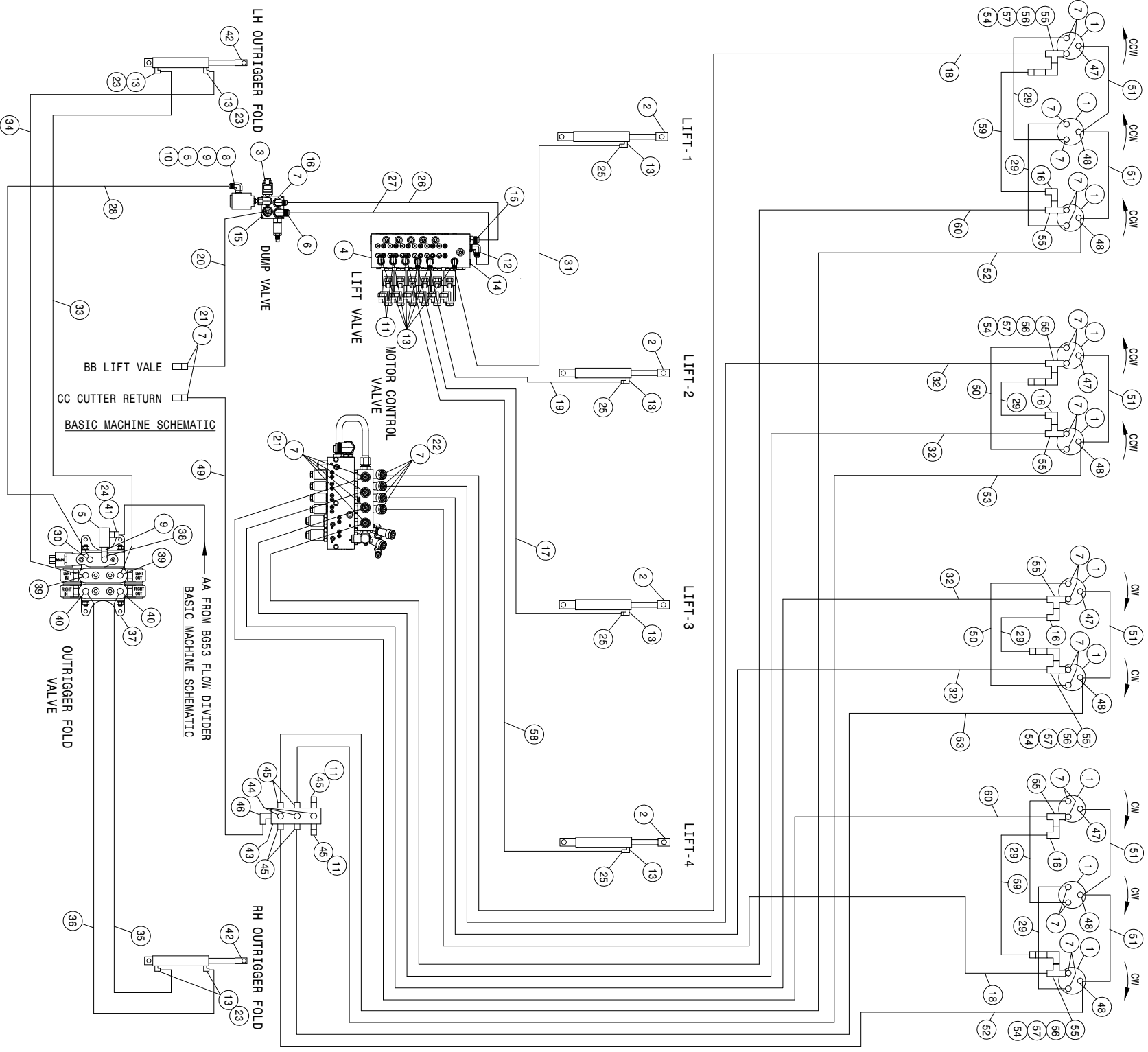

DTS10C 10R CUTR 4L LS HYD SCHEM 2010
REFERENCE DRAWING NO. 499211

DET.	QTY	PART NO.	DESCRIPTION	DET.	QTY	PART NO.	DESCRIPTION
1	10	610755	BARNES HYD MOTOR, D-SERIES 01	31	1	611246	04-482TC-06FJX-06FJX-174
2	4	621564	HYD CYL,2.00 X 11.00 X 1.50 1W	32	4	616168	08-482TC-08FJX-08FJX-139
3	1	606330	DUMP MANIF VALVE SAUER	33	1	615616	04-482TC-06FJX-06FJX-65
4	1	606285	LIFT VALVE,STS COMBO,SAUER	34	1	615314	04-482TC-06FJX-06FJX-50
5	2	605615	HYD FILTER,INLINE 25M 9/16FOR	35	1	616636	04-482TC-06FJX-06FJX-143
6	1	611128	7/8MJIC-90-7/8MOR LBO	36	1	616191	04-482TC-06FJX-06FJX-138
7	1	611125	3/4MJIC-3/4MOR ADPTR	37	1	606090	BRAND HYD VALVE, 2-SECT SER 36
8	1	618464	3/4MJIC-90-3/4MOR LG LBO	38	1	618183	3/4MJIC-90-7/8MOR LBO
9	2	618692	3/4FJIC SWIV-9/16MOR ADPTR	39	2	618115	9/16MJIC-90-3/4MOR LBO
10	1	618249	3/4MJIC-90-9/16MOR LBO	40	2	618709	9/16MJIC-90-3/4MOR EX LG LBO
11	4	618531	9/16FJIC CAP NUT	41	1	618345	9/16MOR-3/8MNP ADPTR
12	1	618241	3/4MJIC-90-3/4MOR LBO	42	2	621520	HYD CYL, 2.00 X 10.00 X 1.000
13	14	618119	9/16MJIC-90-9/16MOR LBO	43	1	606021	HYD RETURN MANIF,3/4FOR,9-PORT
14	1	618754	9/16MOR PLUG, HEX SOCKET	44	3	611159	3/4MOR PLUG, HEX HEAD
15	2	611126	7/8MJIC-7/8MOR ADPTR	45	6	618109	9/16MJIC-3/4MOR ADPTR
16	5	618609	3/4MJIC-90-3/4FJIC SWIV LBO	46	1	618474	3/4MJIC-90-1 1/16MOR LBO
17	1	614152	04-482TC-06FJX-06FJX-114	47	4	618530	9/16MJIC-1/8MNP ADPTR
18	2	614387	08-482TC-08FJX-08FJX-267	48	6	618546	1/8MNP RUN TEE-9/16MJIC
19	1	615729	04-482TC-06FJX-06FJX-84	49	1	616135	08-451TC-08FJX-08FJX-50
20	1	616006	08-482TC-08FJX-10FJX-33	50	2	614368	08-482TC-08FJX-08FJX-60
21	6	618696	HYD COUPLER,FEM 1/2B, 3/4FOR	51	6	616422	04-482TC-06FJX-06FJX90-50
22	4	618697	HYD COUPLER,MALE 1/2B, 3/4FOR	52	2	614377	04-482TC-06FJX-06FJX-258
23	4	618731	9/16JIC-.025 ORIFICE ADPTR	53	2	611202	04-482TC-06FJX-06FJX-136
24	1	618646	HYD QUICK CPLR, MALE .375NPS	54	4	611147	3/4MJIC-1/2MNP ADPTR
25	4	618733	9/16JIC-.042 ORIFICE ADPTR	55	8	618451	3/4FJIC SW RUN TEE-3/4MJIC
26	1	616938	06C1T-08FJX-06FJX90-25	56	4	618620	3/4FJX-90-1/2MNP ADPTR
27	1	616939	08C1T-08FJX-10FJX-27	57	4	690338	LINE CHECK VALVE HYD .50NPT
28	1	616937	06-482TC-06FJX-08FJX-27	58	1	616421	04-482TC-06FJX-06FJX-228
29	6	616025	08-482TC-08FJX-08FJX-50	59	2	616031	08-482TC-08FJX-08FJX-83
30	1	618327	3/4MJIC-7/8MOR ADPTR	60	2	614384	08-482TC-08FJX-08FJX-237

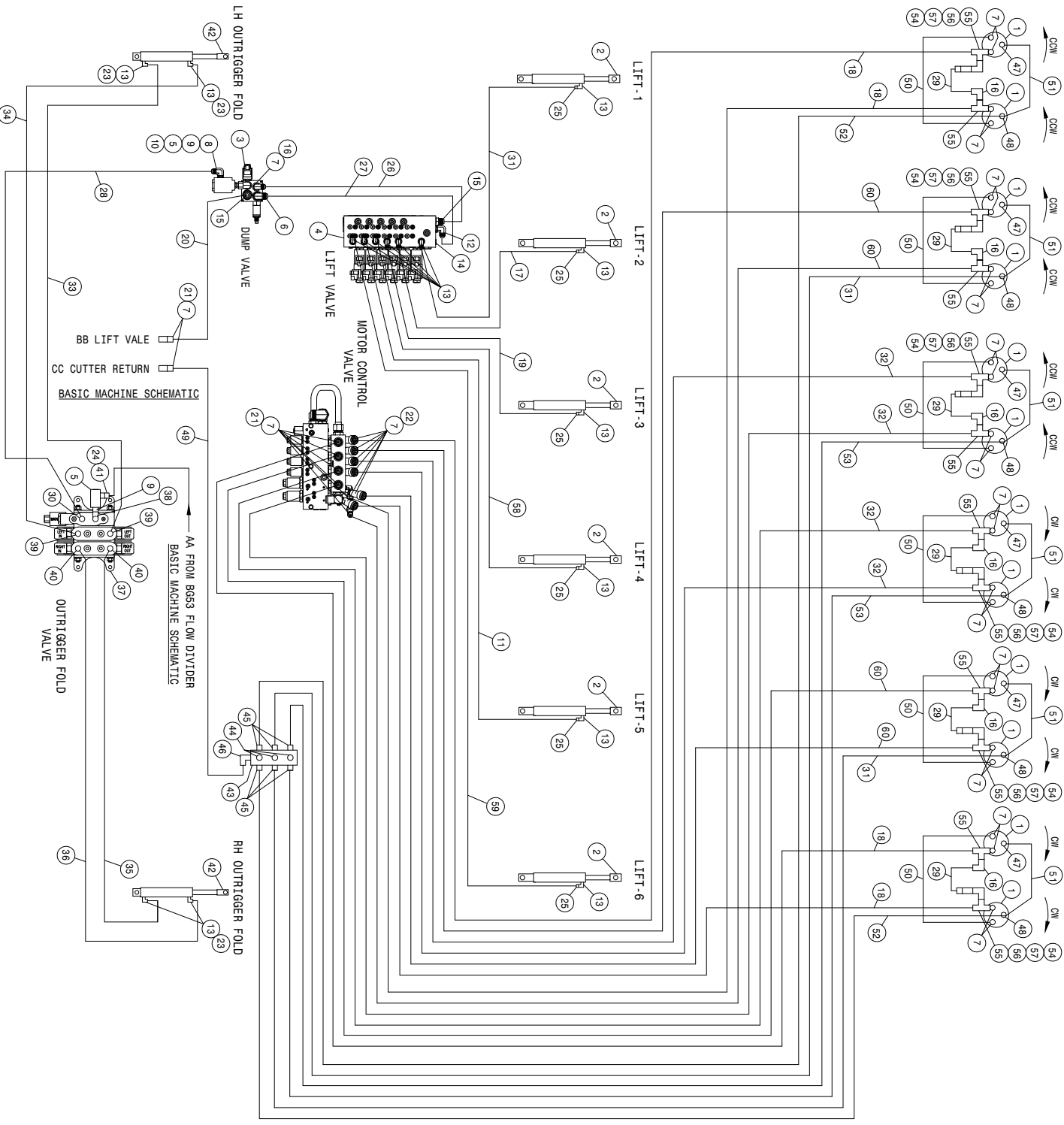

DTS10C 12R CUTR 6L LS HYD SCHEM 2010
REFERENCE DRAWING NO. 499212

DET.	QTY	PART NO.	DESCRIPTION	DET.	QTY	PART NO.	DESCRIPTION
1	12	610755	BARNES HYD MOTOR, D-SERIES	01	31		
2	6	621564	HYD CYL, 2.00 X 11.00 X 1.50 1W	32	4	616168	08-4821TC-08FJX-08FJX-139
3	1	606330	DUMP MANIF VALVE	33	1	615616	04-4821TC-06FJX-06FJX-65
4	1	606285	LIFT VALVE, STS COMBO, SAUER	34	1	615314	04-4821TC-06FJX-06FJX-50
5	2	605615	HYD FILTER, INLINE 25M 9/16FOR	35	1	616636	04-4821TC-06FJX-06FJX-143
6	1	611128	7/8MJIC-90-7/8MOR LBO	36	1	616191	04-4821TC-06FJX-06FJX-138
7	1	611125	3/4MJIC-3/4MOR ADPTR	37	1	606090	BRAND HYD VALVE, 2-SECT SER 36
8	1	618464	3/4MJIC-90-3/4MOR LG LBO	38	1	618183	3/4MJIC-90-7/8MOR LBO
9	2	618692	3/4FJIC SWIV-9/16MOR ADPTR	39	2	618115	9/16MJIC-90-3/4MOR LBO
10	1	618249	3/4MJIC-90-9/16MOR LBO	40	2	618709	9/16MJIC-90-3/4MOR EX LG LBO
11	1	616419	04-4821TC-06FJX-06FJX-204	41	1	618345	9/16MOR-3/8MNPT ADPTR
12	1	618241	3/4MJIC-90-3/4MOR LBO	42	2	621520	HYD CYL, 2.00 X 10.00 X 1.000
13	16	618119	9/16MJIC-90-9/16MOR LBO	43	1	606021	HYD RETURN MANIF, 3/4FOR, 9-PORT
14	1	618754	9/16MOR PLUG, HEX SOCKET	44	3	611159	3/4MOR PLUG, HEX HEAD
15	2	611126	7/8MJIC-7/8MOR ADPTR	45	6	618109	9/16MJIC-3/4MOR ADPTR
16	7	618609	3/4MJIC-90-3/4FJIC SWIV LBO	46	1	618474	3/4MJIC-90-1 1/16MOR LBO
17	1	611210	04-4821TC-06FJX-06FJX-156	47	6	618530	9/16MJIC-1/8MNPT ADPTR
18	4	616170	08-4821TC-08FJX-08FJX-295	48	6	618546	1/8MNPT RUN TEE-9/16MJIC
19	1	615729	04-4821TC-06FJX-06FJX-84	49	1	616135	08-451TC-08FJX-08FJX-50
20	1	616006	08-4821TC-08FJX-10FJX-33	50	6	614368	08-4821TC-08FJX-08FJX-60
21	8	618696	HYD COUPLER, FEM 1/2B, 3/4FOR	51	6	616422	04-4821TC-06FJX-06FJX-90-50
22	6	618697	HYD COUPLER, MALE 1/2B, 3/4FOR	52	2	614504	04-4821TC-06FJX-06FJX-301
23	4	618731	9/16JIC .025 ORIFICE ADPTR	53	2	611202	04-4821TC-06FJX-06FJX-136
24	1	618646	HYD QUICK CPLR, MALE .375NPS	54	6	611147	3/4MJIC-1/2MNPT ADPTR
25	6	618733	9/16JIC .042 ORIFICE ADPTR	55	12	618451	3/4FJIC SW RUN TEE-3/4MJIC
26	1	616938	06C1T-08FJX-06FJX-25	56	6	618620	3/4FJX-90-1/2MNPT ADPTR
27	1	616939	08C1T-08FJX-10FJX-27	57	6	690338	LINE CHECK VALVE HYD .50NPT
28	1	616937	06-4821TC-06FJX-08FJX-27	58	1	614308	04-4821TC-06FJX-06FJX-109
29	6	616025	08-4821TC-08FJX-08FJX-50	59	1	615731	04-4821TC-06FJX-06FJX-290
30	1	618327	3/4MJIC-7/8MOR ADPTR	60	4	614384	08-4821TC-08FJX-08FJX-237

ABBREVIATIONS

A/C - AIR CONDITIONER	MT - MOUNT
ADPTR - ADAPTER	MTR - MOTOR
AGI - AGITATOR	P/N - PART NUMBER
ALT - ALTERNATOR	PLT - PLATE
ASSY - ASSEMBLY	QTY - QUANTITY
BRKT - BRACKET	RED - REDUCER
DET - DETAIL	REF - REFERENCE
DISPL - DISPLACEMENT	REST - RESTRICTOR
EL - ELBOW	REQ - REQUIRED
EXT - EXTENSION	SHFT - SHAFT
FLO - FLOW	SOL - SOLUTION
FNPT - FEMALE NATIONAL PIPE THREAD	STRG - STEERING
FOR - FEMALE O-RING	ST - STREET
FRT - FRONT	SWIV - SWIVEL
HYD - HYDRAULIC	UNC - UNIFIED NATIONAL COURSE
HYDRO - HYDROSTATIC	UNF - UNIFIED NATIONAL FINE
LG - LONG	V - VOLT
LWR - LOWER	W/ - WITH
MJIC - MALE J.I.C.	WHL - WHEEL
MOR - MALE O-RING	WLD - WELDMENT

INDEX

-A-

ABBREVIATIONS..... 178
ACCUMULATOR CYLINDER..... 78, 80, 81
AGITATOR
 IMPELLER..... 55, 57
 SHAFT..... 55, 57
 SHIELD..... 55, 57
 SOLUTION..... 55, 57
 VARIABLE FLOW CONTROL..... 15
AIR BAG..... 22, 24, 26, 28
AIR CLEANER..... 6
 BAND..... 6
 FILTER..... 6
 HOOD..... 6
 HOSE..... 6
AIR CONDITIONER..... 34
 BLOWER..... 34
 COMPRESSOR..... 11
 CONDENSOR..... 19
 DRYER..... 19
 EVAPORATOR..... 34
 FILTER..... 34
AIR INTAKE..... 19
AIR LINE..... 9, 46
AIR REGULATOR..... 46
AIR SEAT..... 43
AIR TANK..... 8, 9
ANTENNA..... 34

-B-

BATTERY..... 53
 BOX..... 53
 CABLE..... 53
 HOLD DOWN..... 53
BEARING, LEG..... 22, 24, 26, 28
BELT..... 4, 5
 BINDING POST..... 41
 BLADE, WIPER..... 32
 BLOWER MOTOR..... 34
BOOM..... 86, 87, 88, 89, 90
 CONTROL VALVE..... 79
 CRADLE..... 52
 HINGE..... 88, 90
 LIGHTS..... 85
 SOLENOID..... 59, 60, 61, 62, 63, 65, 66
 SPRING..... 80, 81
BOX FUSE..... 42
BREAKAWAY..... 78
BREAKER CIRCUIT..... 42
BUMPER, LEG..... 22, 24, 26, 28

-C-

CAB..... 32
 LIGHTS..... 32, 34
CABLE,
 BATTERY..... 53
 GROUND..... 53
 HYDROSTATIC..... 40
 CANTRAK..... 37
 CASE DRAIN MANIFOLD..... 110
 CIRCUIT BREAKER..... 42
 CLAMP,
 AIR CLEANER..... 6
 MUFFLER..... 5
 CONDENSOR..... 19
 CONSOLE..... 38, 43
 CRADLE
 BOOM..... 52
 SOLUTION TANK..... 54, 56
 CROP GUIDE..... 23, 25, 27, 29
 CUTTER HEAD..... 120
 CYLINDER
 ACCUMULATOR..... 86, 87
 FOLD..... 78, 84
 LEVEL..... 83
 LIFT..... 82
 STEERING..... 30
 TREAD ADJUST..... 96

-D-

DECALS..... 124, 125
DEPTH COMMAND..... 104
DIAGRAMS, WIRING..... 126
DOOR..... 33
 LATCH..... 33
DRAIN VALVE..... 8, 9
DRINK HOLDER..... 39
DRIVE DISK..... 5
DUMP VALVE..... 106
DYER, A/C..... 19
BELT..... 11

-E-

ENGINE..... 4, 5
 HOOD..... 44
EXHAUST STACK..... 5

-F-

FAN..... 5
 SPACER..... 5
FEEDER TEE..... 78

FENCE ROW.....68,69
 FILTER,
 AIR CLEANER.....6
 AIR CONDITIONER.....34
 ENGINE.....4
 FUEL.....5
 HYDRAULIC.....11
 MINDER.....46
 OPTION.....107
 FLOW DIVIDER.....14,16
 FLOW METER.....59,60,63,64
 FLUSHING VALVE.....10
 FOAM.....32,35
 FOAMER TANK.....92
 FOAMER VALVE.....98
 FOLD CYLINDER.....78,84,115
 FRESH WATER TANK.....51
 FUEL,
 GAUGE.....37
 SELECTOR VALVE.....49
 TANK.....49
 TANK MOUNT.....53,54
 FUSE.....42
 BOX.....42

-G-

GAS SPRING.....36,39,44
 GAUGE
 AIR REGULATOR.....46
 PRESSURE.....46,59,60,63,64
 TREAD ADJUST.....50
 GRAB HANDLE.....32
 GLASS.....32,33
 GROUND CABLE.....56
 GROUND STRAP.....32
 GUIDE, STALK.....23,25,27,29

-H-

HANDLE,
 DOOR.....33
 GRAB.....32
 HANDRAIL.....50
 HEADLIGHT.....32,58,83
 HEADLINER.....34
 HEATER COIL.....34
 HINGE, BOOM.....94,90
 HOOD,
 AIR CLEANER.....6
 ENGINE.....44
 HOOK, RUBBER.....45
 HOSE, RADIATOR.....5
 HOISING, SOLUTION.....71,72,73,74
 HOUR METER.....37
 HUB, TORQUE.....23,25,27,29

HYDRAULIC
 DAMPER.....33
 FILTER.....11
 SOLENOID VALVE.....12
 SCHEMATIC.....150
 TANK.....20
 HYDROSTATIC
 CABLE.....40
 LEVER.....40

-I-

IGNITION SWITCH.....41
 INJECTION PLATFORM.....104
 INSTRUMENT PANEL.....37

-L-

LADDER.....47,48
 LATCH, DOOR.....33
 LEG,
 BEARING.....22,24,26,28
 BRACE.....58
 BUMPER.....22,24,26,28
 FRONT.....22,24
 REAR.....26,28
 LEVEL CYLINDER.....78
 LEVER,
 HYDROSTATIC.....40
 LIFTARM.....77
 LIFT CYLINDER.....82
 LIFT VALVE.....108
 LIGHT,
 BOOM.....85
 CAB.....32,34
 SWITCH.....34
 LS CONTROL.....102

-M-

MIRROR.....32
 MONITOR, FLOW MAX 110.....99
 MOTOR
 BLOWER.....34
 STEERING.....36
 WHEEL.....23,25,27,29
 WIPER.....32
 MOUNT,
 CAB.....34
 MOTOR.....4,5
 PUMP.....7
 MUFFLER.....5
 CLAMP.....5
 MULLION.....44

-N-

NOZZLE, REAR WHEEL.....70

-0-
 OIL
 COOLER.....19
 PRESSUR.....37
 TANK.....20
 OUTRIGGER.....111,112,113,114

-P-
 PAD, RADIATOR.....19
 PANEL, SWITCH.....41
 PLATFORM, INJECTION.....97
 POWER POINT.....43
 PRESSURE
 GAUGE.....41,59,60,63,64
 PUMP,
 SOLUTION.....76
 SUNDSTRAND.....7

-Q-
 QUAD PULLER.....122
 QUICK FILL.....67

-R-
 RADIATOR.....19
 HOSE.....5
 PAD.....19
 SHROUD.....19
 RADIO.....34
 RAVEN, VFC.....17
 REAR WHEEL NOZZLE.....70
 RECEPTACLE BRACKET.....101
 RELAY.....42
 RELIEF VALVE.....14
 RETURN TEE ASSEMBLY.....18
 RIM.....21
 RINSE
 TANK.....91
 RUBBER,
 HOOK.....45
 MOUNT.....4,5,7,32

-S-
 SCHEMATIC, HYDRAULIC.....150
 SEAT.....43
 SERVICE PLATFORM.....50
 SHEET METAL.....44,45
 SHIELD, TANK.....58
 SHROUD, RADIATOR.....19
 SIDERAIL.....50
 SMV SIGN.....50
 SOLENOID, BOOM.....59,60,61,62,63,64
 SOLUTION
 HOISING.....71,72,73,74

PUMP.....76
 TANK CRADLE.....54,56
 SPACER, FAN.....5
 SPEAKER.....34
 SPRING, GAS.....36,39,44
 STALK GUIDE.....23,25,27,29
 STEERING
 COLUMN.....36
 CYLINDER.....30
 MOTOR.....36
 WHEEL.....36
 STRAINER,
 SOLUTION.....54,56
 STRAP, GROUND.....32
 SUNDSTRAND PUMP.....7
 SWITCH,
 IGNITION.....41
 LIGHT.....41
 PANEL.....41
 SOLUTION.....32

-T-
 TAILLIGHT.....50
 TANK,
 AIR.....8,9
 FOAMER.....92
 FRESH WATER.....51
 HYDRAULIC.....20
 MOUNTS.....58
 RINSE.....91
 SHIELD.....58
 SOLUTION.....54,56
 TEE, FEEDER.....75
 TEMPERATURE
 GAUGE.....37

TIE PLATE.....13
 TIE ROD.....31
 TIRE.....21
 TRANSOM.....78
 TREAD ADJUST.....95
 CYLINDER.....96
 GAUGE.....50
 VALVE.....94
 TORQUE, HUB.....23,25,27,29

-V-
 VALVE,
 AIRBAG.....22,24,26,28
 DIVERT, FOAMER.....98
 DRAIN.....8
 ELECTRIC BOOM.....79
 FENCE ROW.....68,69
 FLUSHING.....10
 FUEL SELECTOR.....49

-V-

VALVE,	
DUMP.....	106
FOLD, OUTRIGGER.....	109
HYDRAULIC SOLENOID.....	12
LIFT.....	108
MOTOR CONTROL.....	105
RELIEF.....	14
TREAD ADJUST.....	94
VARIABLE FLOW CONTROL.....	13, 15, 17

-W-

WHEEL MOTOR.....	23, 25, 27, 29
WHEEL, STEERING.....	36
WINDSHIELD WASHER.....	100
WIPER,	
BLADE.....	32
MOTOR.....	32
WINDSHIELD.....	32