

**2018 NTB  
OPERATOR'S MANUAL  
493753**





**HAGIE**  
CONTENTS

---

**1 – INTRODUCTION**

A Word From Hagie Manufacturing Company ..... 1-1  
About This Manual ..... 1-1  
Safety Messages Used In This Manual ..... 1-2  
Service and Assistance ..... 1-2  
Product Warranty ..... 1-2  
Specifications ..... 1-3

**2 – SAFETY AND PRECAUTIONS**

Intended Use ..... 2-1  
Safety Precautions ..... 2-1  
Safety Decals ..... 2-3

**3 – OPERATING YOUR NTB**

Lighting - Attachment Headlights ..... 3-1  
Fold Procedure ..... 3-3  
Float Operation ..... 3-7  
Application ..... 3-10

**4 – MAINTENANCE AND STORAGE**

Service - Lubrication ..... 4-1  
Storage ..... 4-2

**5 – MISCELLANEOUS**

Transporting ..... 5-1  
Gauge Wheel Adjustment ..... 5-1  
Coulter Adjustment ..... 5-2  
Quick-Tach System ..... 5-3



## SECTION 1 – INTRODUCTION

---

### **A WORD FROM HAGIE MANUFACTURING COMPANY**

Congratulations on the purchase of your Nitrogen Toolbar (NTB)! We recommend that you review this operator's manual and become familiar with operating procedures and safety precautions before attempting to operate your NTB.

As with any piece of equipment, certain operating procedures, service, and maintenance are required to keep your NTB in top running condition. We have attempted herein to cover all of the adjustments required to fit varying conditions. However, there may be times when special care must be considered.

*NOTE: The operator is responsible for inspecting the NTB and having parts repaired or replaced when continued use of the product causes damage or excessive wear to other parts.*

Hagie Manufacturing Company reserves the right to make changes in the design and material of any subsequent NTB without obligation to existing units.

Thank you for choosing a Hagie NTB and we ensure you of our continued interest and support in its optimal performance for you. We are proud to have you as a customer!

### **ABOUT THIS MANUAL**

#### **NOTICE**

The purpose of this manual is to guide you in operating the NTB. Read this manual in addition to the sprayer operator's manual, and all other literature that is included with the machine. This manual is only intended to cover the NTB attachment and any differences in the operation of the sprayer controls. Refer to your sprayer operator's manual for complete instructions on machine operation.

#### **NOTICE**

Any pictures or illustrations contained within this manual that depict situations with shields, guards, rails, or lids removed are for demonstration only. Keep all shields and safety devices in place at all times.

#### **NOTICE**

Reference to right and left-hand used throughout this manual refers to the position when seated in the operator's seat facing forward.

This manual will aid you in the proper operation and service of your Nitrogen Toolbar (NTB). It is the responsibility of the user to read the operator's manual and comply with the correct and safe operating procedures, as well

as maintain the product according to the service information provided in the *Maintenance and Storage Section* elsewhere in this manual.

Photographs and illustrations used in this manual are of general nature only. Some of the equipment described and/or shown may or may not be available on your NTB.

Information described in this manual was correct at the time of printing. Because of Hagie Manufacturing Company's continuous product improvement, certain information may not be included in this manual. To obtain the most current operator's manual for your attachment, please visit [www.hagie.com](http://www.hagie.com).

Keep this manual in a convenient place for easy reference. This manual is considered a permanent fixture of the product. In the event of resale, this manual must accompany the NTB.

If you do not understand any part of this manual or require additional information or service, contact your local John Deere dealer for assistance.

---

## SAFETY MESSAGES USED IN THIS MANUAL

The following safety messages found throughout this manual alert you of situations that could become potentially dangerous to the operator, service personnel, or equipment.

 <b>DANGER</b>
The signal word DANGER indicates a hazardous situation which, if not avoided, will result in death or serious injury.

 <b>WARNING</b>
The signal word WARNING indicates a hazardous situation which, if not avoided, could result in death or serious injury.

 <b>CAUTION</b>
The signal word CAUTION indicates a hazardous situation which, if not avoided, could result in minor or moderate injury. CAUTION may also be used to alert against unsafe practices associated with events which could lead to personal injury.

<b>NOTICE</b>
The signal word NOTICE indicates operator awareness which, if not avoided, may result in personal or property damage.

*NOTE: A "Note" is intended to make special mention of, or remark on.*

---

## SERVICE AND ASSISTANCE

Please contact your local John Deere dealer for service and assistance.

---

## PRODUCT WARRANTY

Please contact your local John Deere dealer for further information.

## SPECIFICATIONS

Hagie Manufacturing Company offers its Nitrogen Toolbar (NTB) in 12-row, 16-row, 18-skip row, and 24-skip row configurations, depending on model. The 6-ft. (182 cm) clearance (30/40' NTB) allows growers to side-dress nitrogen later in the growing season, in some situations, after tassels have topped.

NTB units are set for 30" (76 cm) rows, but some can accommodate 20, 22, or 36-inch (50, 55, or 91 cm) rows. They are capable of applying 80 to 100 lbs. (36 to 45 kg) of nitrogen at 14 to 16 mph (22 to 25 km/h), which is approximately twice the speed of tractor-pulled units.

Description	12-Row NTB	16-Row NTB	18-Row NTB	24-Row NTB
Skip Row	N/A	N/A	X	X
Standard Coulter Row Units	11	15	9	12
Electro-Hydraulic Fold/Lift/Level	X	X	X	X
100 PSI (6.9 bar) Glycerin-Filled Pressure Gauge	X	X	X	X
Solution Control Valves	3	3	3	3 (40'NTB)

### Fold Points (30' NTB)

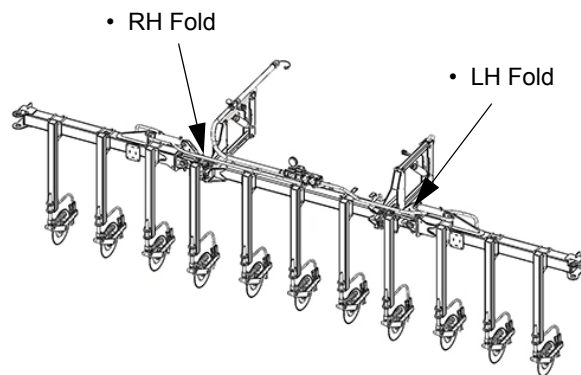

30' NTB Fold Points  
(Unfolded position shown)  
-Typical View

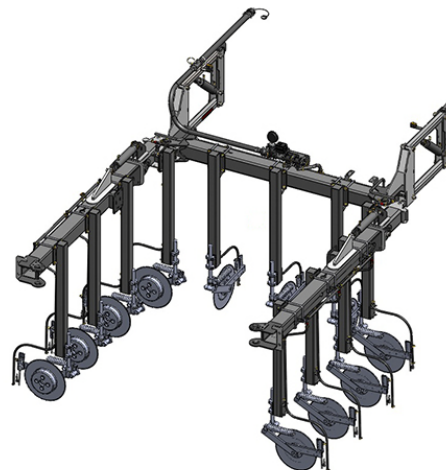

30' NTB Fold Points  
(Folded position shown)  
-Typical View

## Fold Points (40' NTB)

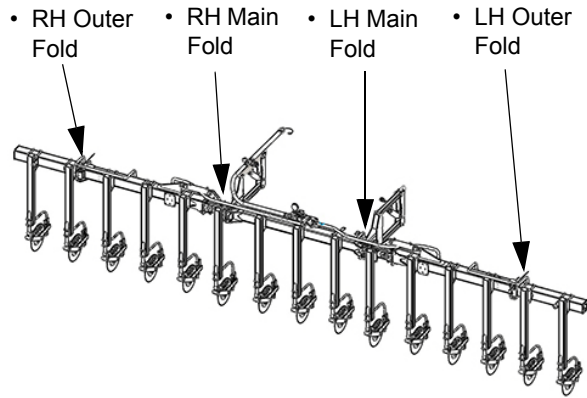

40' NTB Fold Points  
(Unfolded position shown)  
-Typical View

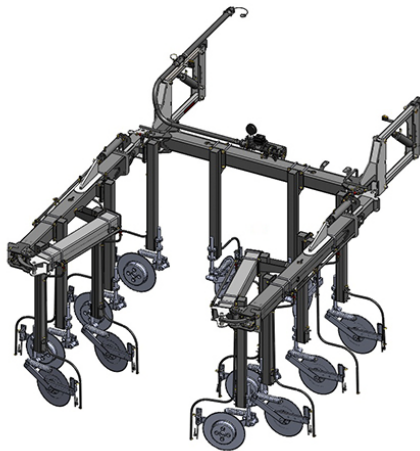

40' NTB Fold Points  
(Folded position shown)  
-Typical View

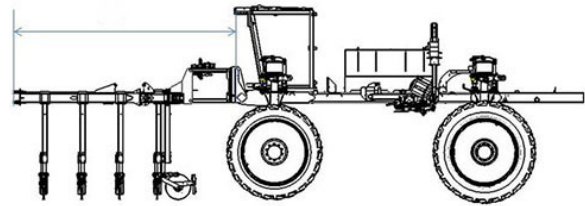

30' NTB

- Length (from front of machine to front of folded NTB) = 175"/14'-7" (444.5 cm)

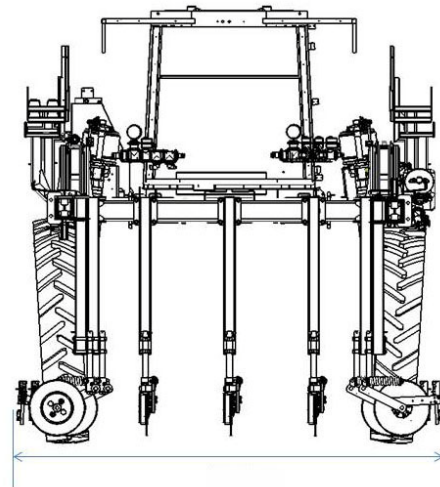

30' NTB

- Overall Folded Width = 146"/12'-2" (370.8 cm)

## 40' NTB Dimensions

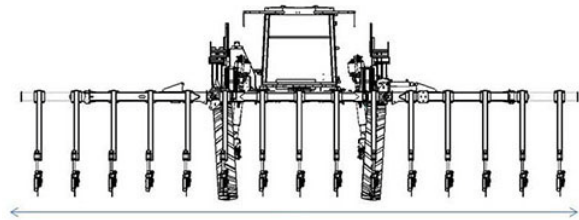

40' NTB

- Overall Unfolded Width = 449.5"/37'-5" (11.4 m)

## NTB Transport Dimensions

### 30' NTB Dimensions

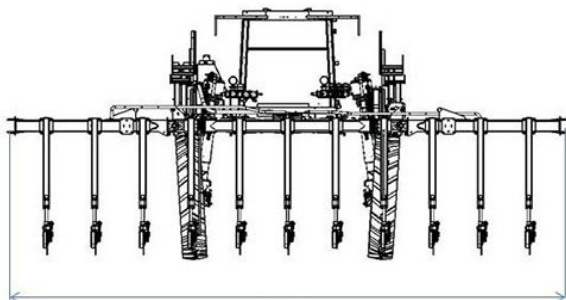

30' NTB

- Overall Unfolded Width = 350"/29'-2" (889 cm)

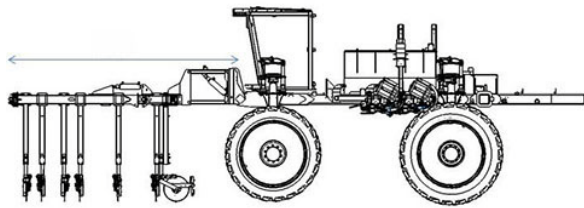

40' NTB

- Length (from front of machine to front of folded NTB) = 180"/15' (457.2 cm)

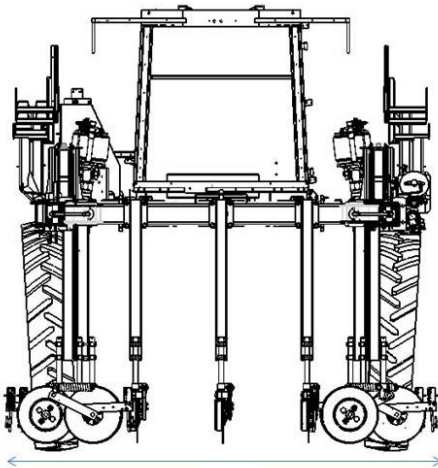

40' NTB

- Overall Folded Width = 150"/12'-6" (381 cm)

## NTB Layout

The following illustrations define the NTB design and will aid in identifying the various toolbar configurations.

## 30' NTB

12-Row/30" (76.2 cm) Spacing



30' NTB

12-Row/30" (76.2 cm) Spacing

18-Skip Row/20" (50.8 cm) Spacing



30' NTB

18-Skip Row/20" (50.8 cm) Spacing



**40' NTB**

**16-Row/30" (76.2 cm) Spacing**



40' NTB  
16-Row/30" (76.2 cm) Spacing

**24-Skip Row/20" (50.8 cm) Spacing**



40' NTB  
24-Skip Row/20" (50.8 cm) Spacing

**NTB Weight**

(Approximate)

**30' NTB**

- 4,776 lbs./2,166 kg

**40' NTB**

- 5,996 lbs./2,719 kg



## SECTION 2 – SAFETY AND PRECAUTIONS

### INTENDED USE

#### NOTICE

This attachment is designed for and intended to be used for the application of nitrogen to field crops. Use in any other way or for any other purpose is considered misuse of this attachment.

Most accidents occur as the result of failure to follow basic and fundamental safety rules and precautions. Recognizing potential safety hazards, following correct and safe operating procedures described in this manual, and complying with safety warnings located throughout the machine and attachment may reduce the risk of accidents.

There is no way to completely eliminate the potential for danger when operating agricultural equipment. Therefore, you must study this operator's manual and understand how to operate the attachment controls for safe operation before using the attachment. Likewise, never let anyone operate the attachment without proper instruction.

Do not operate the attachment for anything other than its intended use. Hagie Manufacturing Company shall not be liable for any damage, injury, or death associated with improper use of the attachment.

Do not make any modifications such as, but not limited to, weldments, add-ons, adaptations, or changes from the original design of the attachment. Such modifications may become safety hazards to you and others and **will void all warranties**.

Replace missing, faded, or damaged safety signs. Refer to "Safety Decals" elsewhere in this section for correct sign and placement.

### SAFETY PRECAUTIONS

#### General Safety

- The hydraulic and electrical control systems are optimized for use with this attachment. Any modification to these systems may lead to unintended or uncontrolled motion. Do NOT install add-on control systems that are not approved by Hagie Manufacturing Company.
- Some conditions cannot be completely safeguarded against without interfering with efficient operation of the machine and/or reasonable accessibility. In these cases, decals have been installed to provide the operator with hazard information. Do NOT remove decals for any reason. If a decal is damaged or missing, contact your local John Deere dealer for replacement.



#### Wear Protective Clothing

- Do not wear loose fitting clothing that could get caught in moving parts. Wear safety equipment that is appropriate for the job.



- Do not store chemical-soaked clothing in the cab. Clean off as much mud and dirt from your shoes as you can before entering the cab.

## Be Prepared

- Be prepared for an emergency. Keep a fire extinguisher handy. Keep a first aid kit and clean water in the cab.
- Make sure to service the fire extinguisher regularly. Keep an accurate inventory of supplies in the first aid kit and dispose of anything that has expired.



## General Maintenance Safety

- Turn off sprayer engine before checking, adjusting, repairing, lubricating, or cleaning any part of the attachment.
- Remove all chemical residue from the work area before performing service/maintenance.
- Disconnect the battery ground cable and turn the Battery Disconnect Switch OFF before servicing the electrical system or welding on an attachment.



## Safe Hydraulic Maintenance

- Always practice personal safety when performing service or maintenance on the hydraulic system.

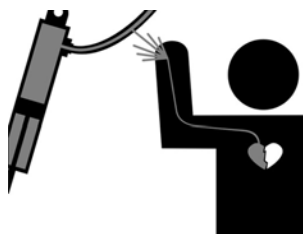

- Use caution when working around hydraulic fluid under pressure. Escaping fluid can have sufficient force to penetrate your skin, causing serious injury. This fluid may also be hot enough to burn.
- Always lower the load or relieve pressure before repairing a hydraulic leak.
- Avoid torching, welding, and soldering near pressurized hydraulic lines. Pressurized lines may accidentally burst when heat goes beyond the immediate flame area.



## Oil-Over-Air Scenarios

- Upon initial startup of the NTB, be ready for possible rapid movement, should some air become trapped in the cylinders.  
**DO NOT ALLOW PEOPLE TO STAND IN LOCATIONS WHERE THE NTB COULD STRIKE THEM!**



- Clear area of personnel, then operate all attachment functions (i.e. main lift, main fold, up/down movement of outer sections, outer folds, and left and right-hand wings) two (2) times simultaneously to force out any air in the system.

## Handle Agricultural Chemicals Safely

Agricultural chemicals used in applications can be harmful to your health and the environment if not used properly.

- Always follow the manufacturer's label for directions of use.
- Never allow chemicals to come in contact with your skin or eyes. Always use the proper Personal Protective Equipment (PPE).
- Never pour chemicals into an empty tank. Always fill tank half full of water first.
- Dispose of empty chemical containers properly.



- Wash spilled chemicals or residue away to prevent corrosion and deterioration.
- Select safe areas to fill, flush, calibrate, and clean sprayer where chemicals will not run off to contaminate people, animals, vegetation, or water supply.
- Never place a spray nozzle to your mouth in an attempt to unplug it.
- Do not spray when wind is in excess of chemical manufacturer's recommendation.
- Store chemicals in their original containers with the label intact.
- Store chemicals in a separate, locked building.
- Wear protective equipment as recommended by the chemical manufacturer.

## SAFETY DECALS

Decals warning you of avoidable danger are located on various parts of the attachment. They are there for your personal safety and protection. DO NOT remove them. They will fracture upon attempted removal and therefore, must be replaced.

Following are locations of important safety decals. Replace them if they are damaged or missing. All safety decals, instructional

decals, or machine striping may be purchased through your local John Deere dealer.

To replace safety decals, ensure the installation area is clean and dry and decide on exact position before you remove the backing paper.

### Safety Decal Locations

**650137**

(Located near electrical box cover)

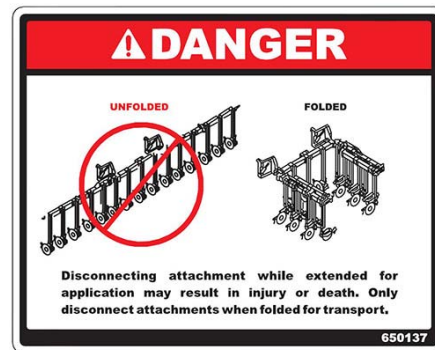

**650178**

(2) - Quick-Tach

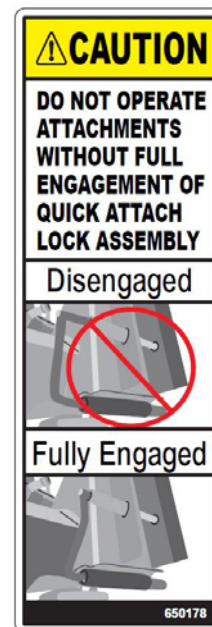

650204

(Located near each fold point)



650219

(Located on each lift arm weldment)



HXE28534

(Located on front cross-member)





## SECTION 3 – OPERATING YOUR NTB

### LIGHTING - ATTACHMENT HEADLIGHTS

When the NTB attachment is connected to the machine, the headlight wiring harness must be disconnected from the machine headlights, and reconnected to the attachment headlights.

*NOTE: The Headlights operate in both Field and Road Mode.*

#### Connecting the Attachment Headlights

1. Disconnect the Headlight Wiring Harness Plug from the back side of machine headlight.



Headlight Wiring Harness Plug  
- Machine View  
(Located on the back side of headlight assembly)  
-Typical View

2. Route the wiring harness to the corresponding headlight on the front of NTB attachment and reconnect the harness plug.



Headlight Wiring Harness Plug  
- Attachment View  
(Located on the back side of headlight assembly)  
-Typical View

3. Repeat on opposite side of machine.
4. The Attachment Headlights are now ready for use.

*NOTE: When the wiring harness is connected to the attachment headlights, the machine headlights will be disabled.*

#### Operating the Attachment Headlights

##### Highway Running Lights (Headlights)

The Highway Running Lights are to be used when traveling on a public roadway at night.



Highway Running Light (2)  
(Mounted on each side of tool bar)  
-Typical View

- Press the Highway Running Lights Switch (located on the steering column) in the DOWN (On) position to activate.
- Press the Highway Running Lights Switch in the UP (Off) position to deactivate.

*NOTE: A Highway Running Lights Indicator (located directly below the switch) will illuminate when activated.*



Highway Running Lights Switch  
(Located on the steering column)  
-Typical View

*NOTE: The Highway Running Lights are enabled when the key is in the ON position. However, prolonged use of these lights without the engine running is not recommended.*

### Hazard/Warning Lights

The Hazard/Warning Lights are to be used at any time, day or night, that you are traveling on a public roadway, unless prohibited by law.



Hazard/Warning Light (2)  
(Mounted on each side of tool bar)  
-Typical View

*NOTE: The machine's drive state must be in Road Mode to activate the Hazard/Warning Lights.*

*NOTE: The Hazard/Warning Lights are tied to battery power and will operate when the machine is off. The flashers are disabled in Field Mode.*

*NOTE: The Hazard/Warning Light Flashers are also activated with the corresponding turn signal.*

- Press the Hazard/Warning Lights Switch (located on the steering column) in the DOWN (On) position to activate.
- Press the Hazard/Warning Lights Switch in the UP (Off) position to deactivate.

*NOTE: The Rotating Beacon (located on the front roof cap) also becomes active when the Hazard/Warning Lights*

Switch is depressed. Refer to “Rotating Beacon” provided in the Safety and Precautions Section of your machine operator’s manual for further information.

**NOTE:** A Hazard/Warning Lights Indicator (located directly below the switch) will illuminate when activated.



Hazard/Warning Lights Switch  
(Located on the steering column)  
-Typical View

### Adjusting the Attachment Headlights

1. Using a 3/4” wrench, loosen the Headlight Mounting Bolt (located on the back side of the headlight assembly).



Headlight Mounting Bolt  
(Located on the back side of headlight assembly)  
-Typical View

2. Pivot headlight to desired position.
3. Re-tighten the Headlight Mounting Bolt.
4. Repeat on opposite side of machine.

### FOLD PROCEDURE

 **WARNING**

Before proceeding, check area around the machine for bystanders, overhead objects, and power lines. Failure to comply may result in serious injury or death.

### Unfold Nitrogen Toolbar (from storage position)

1. Ensure the Hydrostatic Drive Control Handle is in the NEUTRAL position.





Hydrostatic Drive Control Handle  
-Typical View

2. Press the Field/Road Button (located on the Machine Display Home Page) and change the machine's drive state to FIELD mode.

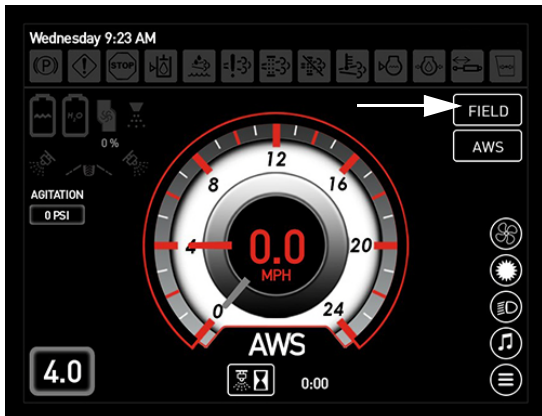

Field/Road Button  
(Located on the Machine Display Home Page)

*NOTE: The machine's drive state cannot be changed unless the Hydrostatic Drive Control Handle is in the NEUTRAL position.*

3. Press and hold the Transom Switch (located on the Hydrostatic Drive Control Handle) in the UP position to raise the NTB up off ground.



Transom Switch - UP  
(Located on the Hydrostatic Drive Control Handle)  
-Typical View

*NOTE: Ensure coulters clear the ground.*

4. Unfold each main fold section by pressing and holding the corresponding Left and Right Boom/NTB Switches (located on the Hydrostatic Drive Control Handle) in the OUT position.

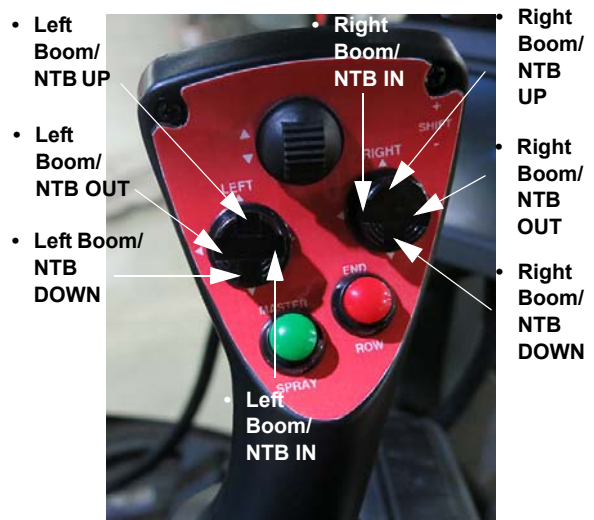

Left and Right Boom/NTB Switches  
(Located on the Hydrostatic Drive Control Handle)  
-Typical View

### Outer Fold Extensions (40' NTB only)

5. Unfold each outer fold extension by pressing and holding the Boom/NTB Extension Switch (located on the side console) in the UP (Out) position.

*NOTE: Both left and right outer fold extensions will unfold simultaneously when this switch is pressed.*



Boom/NTB Extension Switch  
(Located on the side console)  
-Typical View

### Fold Nitrogen Toolbar (to storage position)

1. Ensure the Hydrostatic Drive Control Handle is in the NEUTRAL position.
2. Ensure the machine's drive state is in FIELD mode.
3. Press the Attachment Button (located on the Machine Display Main Menu Page) to navigate to the "NTB Adjustments" screen.



Attachment Button  
(Located on the Machine Display  
Main Menu Page)

4. Press the Float Button (located on the NTB Adjustments screen) and turn Float operation OFF.

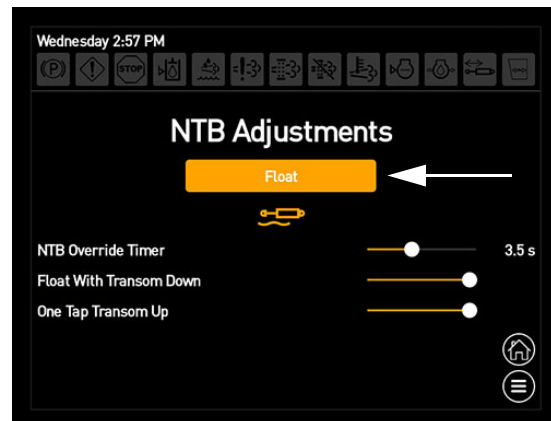

Float Button  
(Located on the Machine Display  
NTB Adjustments Screen)

5. Press and hold the Transom Switch (located on the Hydrostatic Drive Control Handle) in the UP position to raise the NTB up off ground.



Transom Switch - UP  
(Located on the Hydrostatic  
Drive Control Handle)  
-Typical View



Boom/NTB Extension Switch  
(Located on the side console)  
-Typical View

*NOTE: Ensure coulters clear the ground.*

### Outer Fold Extensions (40' NTB only)

NOTICE

Fold each outer fold extension IN before folding in the main fold sections. Failure to comply will result in property damage.

6. Fold in each outer fold extension by pressing and holding the Boom/NTB Extension Switch (located on the side console) in the DOWN (In) position.

*NOTE: Both left and right outer fold extensions will fold simultaneously when this switch is pressed.*

7. Fold in each main fold section by pressing and holding the corresponding Left and Right Boom/NTB Switches (located on the Hydrostatic Drive Control Handle) in the IN position.

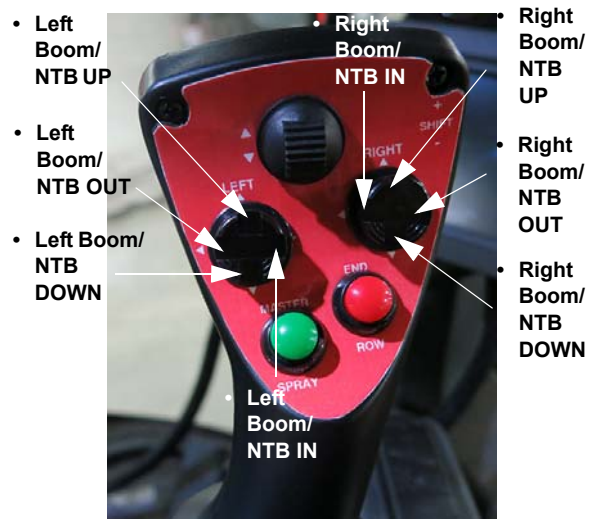

Left and Right Boom/NTB Switches  
(Located on the Hydrostatic  
Drive Control Handle)  
-Typical View

## Adjusting the Main Fold Sections

The main fold sections of the attachment (where the left and right-hand main fold section connects to the main lift) may be adjusted to desired height.

- Press the corresponding Left and Right Boom/NTB Switches (located on the Hydrostatic Drive Control Handle) UP or DOWN to desired position.

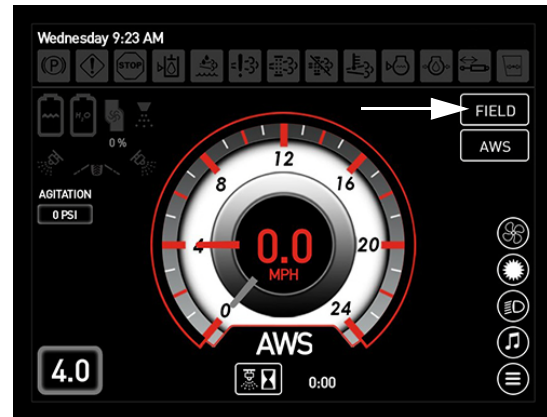

Field/Road Button  
(Located on the Machine Display Home Page)

## FLOAT OPERATION

NOTICE

Ensure Float operation is enabled when operating the NTB. Failure to comply may result in property damage.

Float operation allows the NTB to raise up and down while riding through the field to avoid machine damage due to uneven ground.

Float operation may be activated using various methods. In all options, Float must be enabled through the Machine Display and the machine must be in Field Mode.

### Master Spray Switch (Default Setting)

The Master Spray Switch (located on the Hydrostatic Drive Control Handle) controls both the solution valves and the Float “Down” functions when Float is enabled.

1. Press the Field/Road Button (located on the Machine Display Home Page) and change the machine’s drive state to FIELD mode.

*NOTE: The machine’s drive state cannot be changed unless the Hydrostatic Drive Control Handle is in the NEUTRAL position.*

2. Press the Attachment Button (located on the Machine Display Main Menu Page) to navigate to the “NTB Adjustments” screen.



Attachment Button  
(Located on the Machine Display Main Menu Page)

3. On the “NTB Adjustments” screen, press the Float Button to enable Float operation.

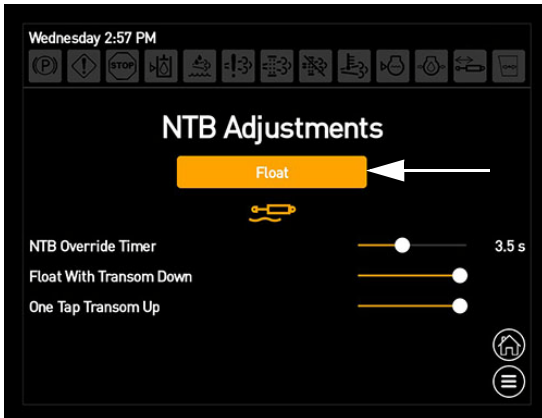

Float Button  
(Located on the Machine Display  
NTB Adjustments Screen)

4. Float will now be activated when the Master Spray Switch is pressed.



Master Spray Switch  
(Located on the Hydrostatic  
Drive Control Handle)  
-Typical View

### Transom Switch (Up/Down) (Default Setting)

To raise or lower the entire lift, the Transom Switch (located on the Hydrostatic Drive Control Handle) must be held in the UP or DOWN positions until desired height is reached.

### Float Adjustments

(NTB Override Timer, Float with Transom Down, and One Tap Transom Up)

#### NTB Override Timer

The NTB Override Timer controls how long the outer sections raise with the transom during Float operation.

1. Press the Attachment Button (located on the Machine Display Main Menu Page) to navigate to the “NTB Adjustments” screen.



Attachment Button  
(Located on the Machine Display  
Main Menu Page)

2. On the “NTB Adjustments” screen, use the slide bar (next to NTB Override Timer) to adjust to desired value (ranging from 0.1 to 10 seconds).

*NOTE: Slide right to increase value, or left to decrease value.*

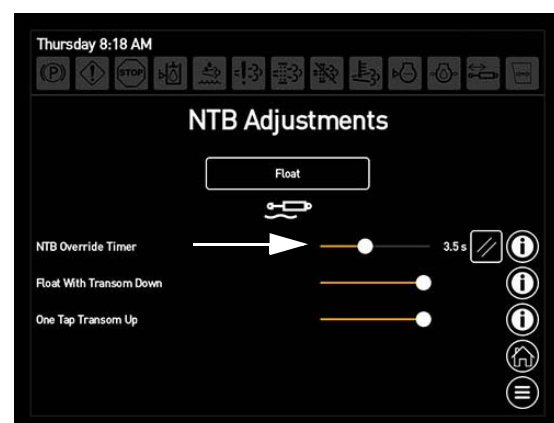

NTB Adjustments Screen

### Float with Transom Down

The Float with Transom Down feature allows the operator to activate Float with the Transom “Down” Switch (located on the Hydrostatic Drive Control Handle).

*NOTE: When Float with Transom Down is turned off, Float will operate with the Master Spray Switch (located on the Hydrostatic Drive Control Handle).*

1. Press and hold the Transom Switch (located on the Hydrostatic Drive Control Handle) in the UP position to raise the NTB to desired height.



Transom Switch - UP  
(Located on the Hydrostatic Drive Control Handle)  
-Typical View

2. Press the Attachment Button (located on the Machine Display Main Menu Page) to navigate to the “NTB Adjustments” screen.



Attachment Button  
(Located on the Machine Display Main Menu Page)

3. On the “NTB Adjustments” screen, swipe the slide bar (next to Float with Transom Down) to the RIGHT to activate.

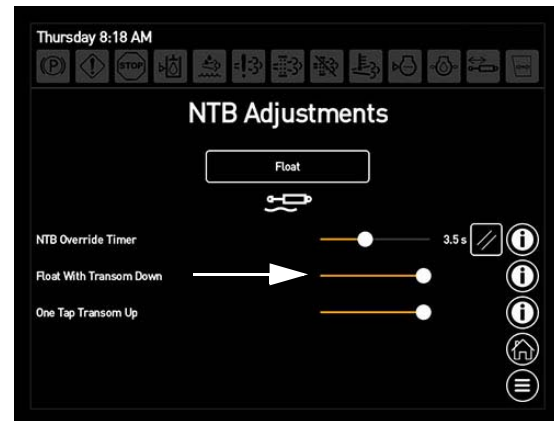

NTB Adjustments Screen

4. Float will now be activated when the Transom “Down” Switch is pressed.

### One Tap Transom Up

The One Tap Transom Up feature allows the operator to fully raise the transom by pressing the Transom Switch (located on the Hydrostatic Drive Control Handle) in the UP position once to raise the entire lift.

*NOTE: When One Tap Transom Up is turned off, the Transom Switch must be held in the UP position the entire time that the cylinders are raising the transom.*

1. Press the Attachment Button (located on the Machine Display Main Menu Page) to navigate to the “NTB Adjustments” screen.



Attachment Button  
(Located on the Machine Display  
Main Menu Page)

2. On the “NTB Adjustments” screen, swipe the slide bar (next to One Tap Transom Up) to the RIGHT to activate.

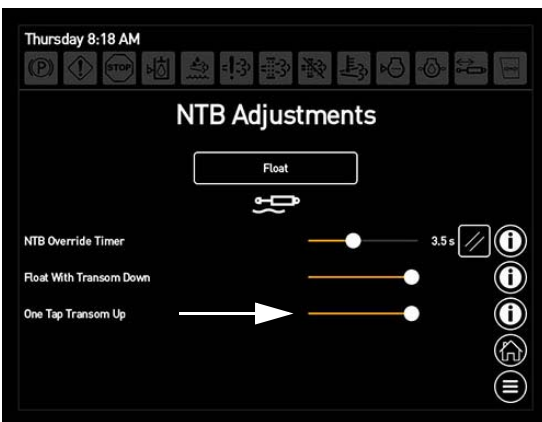

NTB Adjustments Screen

## APPLICATION

### NOTICE

Never attempt to operate the spray system without solution in the tank. Failure to comply will result in severe equipment damage and will void the warranty.

The solution system is a constantly monitored, continuously adjusted computer-controlled system. The cab-mounted digital spray system console receives information from various inputs to help determine gallons per minute (GPM)/liters per minute (l/min) and gallons per acre (GPA)/liters per hectare (l/ha).

*NOTE: The spray system console must be programmed for NTB use before operating.*

The following information refers to components of the solution system and is not intended to replace the manufacturer’s operating instructions. Please read and understand the information provided in this manual, as well as your machine operator’s manual and spray system console manufacturer’s operation manual before operating.

Refer to the operator’s manual of the machine being used to operate the NTB for information on the following:

- Solution System
- Rinse System
- Foam Marker System

## Getting Started

1. Calibrate the Spray System Console (refer to the manufacturer’s operation manual for calibration instructions).
2. Ensure there is adequate amount of solution in the tank.
3. Engage the parking brake.
4. Start the engine.

5. Press the Field/Road Button (located on the Machine Display Home Page) and change the machine's drive state to FIELD.

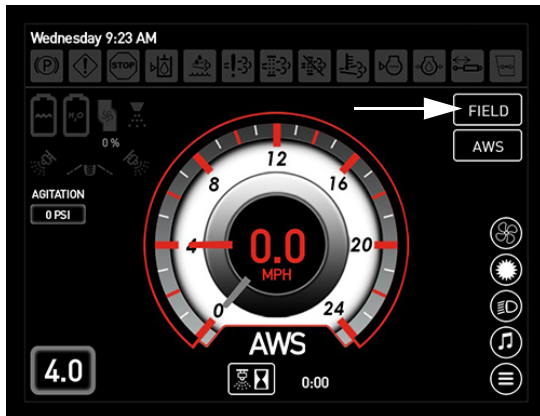

Field/Road Button  
(Located on the Machine Display Home Page)

*NOTE: The drive state of the machine cannot be changed unless the Hydrostatic Drive Control Handle is in the NEUTRAL position and machine speed is less than 0.5 mph/0.8 km/h).*

6. Position tool bar to desired position.
7. Press the Tank Valve Selector Switch (located on the side console) in the UP (Main Tank) position. If desired, activate the Agitation Valve Switch (located on the side console). Press and hold switch UP to increase flow, or DOWN to decrease flow.

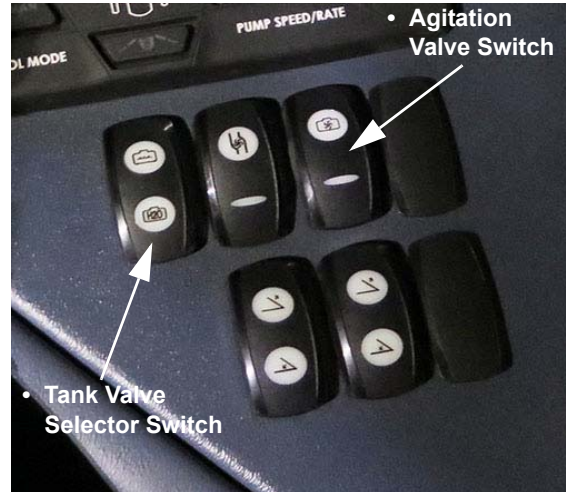

Tank Valve Selector and Agitation Valve Switches  
(Located on the side console)  
-Typical View

*NOTE: Main Tank Valve status and Agitation Valve pressure are displayed on the Machine Display Home Page - Field Mode.*

- Main Tank Indicator
- Agitation Valve Pressure Indicator

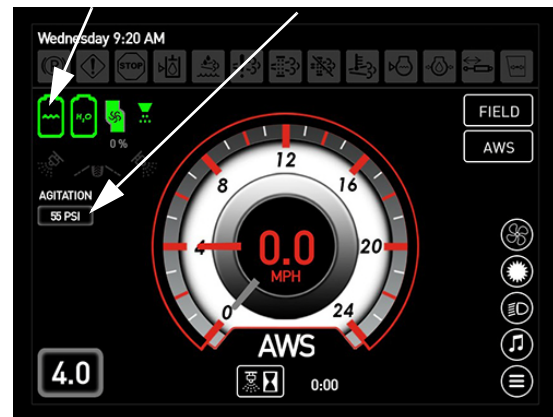

Main Tank and Agitation Valve Pressure Indicators  
(Located on the Machine Display Home Page - Field Mode)

8. Press the Solution Pump Switch (located on the side console) in the UP (On) position.



**NOTICE**

Do not allow the Solution Pump to run continuously while the Boom Solution Valve Switches are off. Failure to comply may generate overheating, causing severe pump damage and will void the warranty.



Solution Pump Switch  
(Located on the side console)  
-Typical View

9. Press the Attachment Button (located on the Machine Display Main Menu Page) to navigate to the “NTB Adjustments” screen.

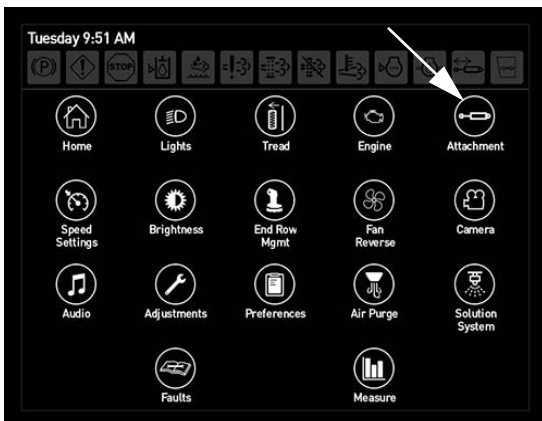

Attachment Button  
(Located on the Machine Display  
Main Menu Page)

10. On the “NTB Adjustments” screen, press the Float Button to enable Float operation.

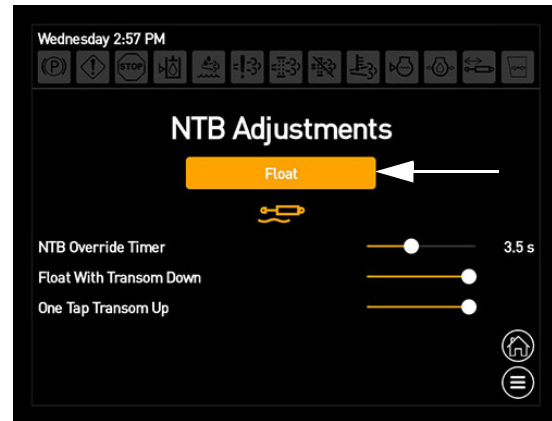

Float Button  
(Located on the Machine Display  
NTB Adjustments Screen)

11. Turn the Master Spray Switch (located on the Hydrostatic Drive Control Handle) ON.



Master Spray Switch  
(Located on the Hydrostatic  
Drive Control Handle)  
-Typical View

*NOTE: When the Master Spray Switch is ON, a Master Spray Indicator (located on the Machine Display Home Page - Field Mode) will illuminate.*

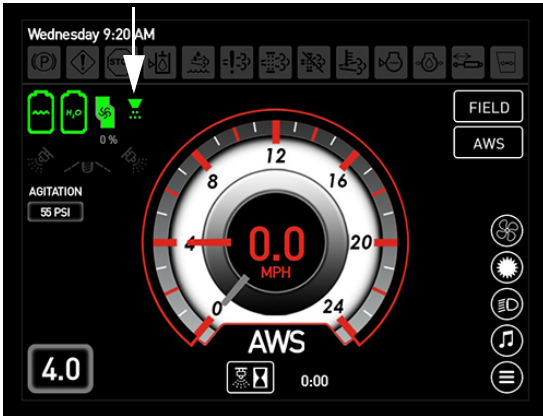

Master Spray Indicator  
(Located on the Machine Display  
Home Page - Field Mode)

14. Frequently observe the pressure gauge. If the pressure drops to zero or the spray pattern deteriorates, turn OFF the Master Spray, Solution Pump, Main Tank Valve, and Agitation Valve Switches until solution is refilled.

12. Press the individual Boom Solution Valve Switches (located on the side console) to the ON (non-illuminated) position.

*NOTE: Each Boom Solution Valve Switch is equipped with an indicator light and will illuminate when the corresponding Boom Solution Valve is OFF.*



Boom Solution Valve Switches  
(Located on the side console)  
-Typical View

*NOTE: Number of sections available will depend on the number of section valves equipped on your NTB.*

13. Slowly move the Hydrostatic Drive Control Handle forward to obtain desired ground speed.



## SECTION 4 – MAINTENANCE AND STORAGE

---

---

### SERVICE - LUBRICATION

#### NOTICE

Failure to properly lubricate pivot and friction points may result in unnecessary wear and damage.

#### NOTICE

SD Polyurea grease (complying with NLGI, EP, and ISO 220 specifications) recommended.

### Grease Points (Zerks)

Lubricate the following Grease Points weekly, or as needed.



#### 30' NTB

- Four (4) Grease Points (A and B) - two (2) per side.

#### 40' NTB

- Six (6) Grease Points (A, B, and C) - three (3) per side.

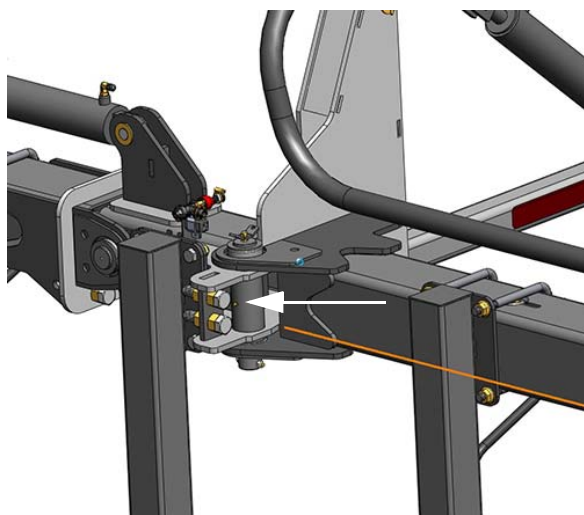
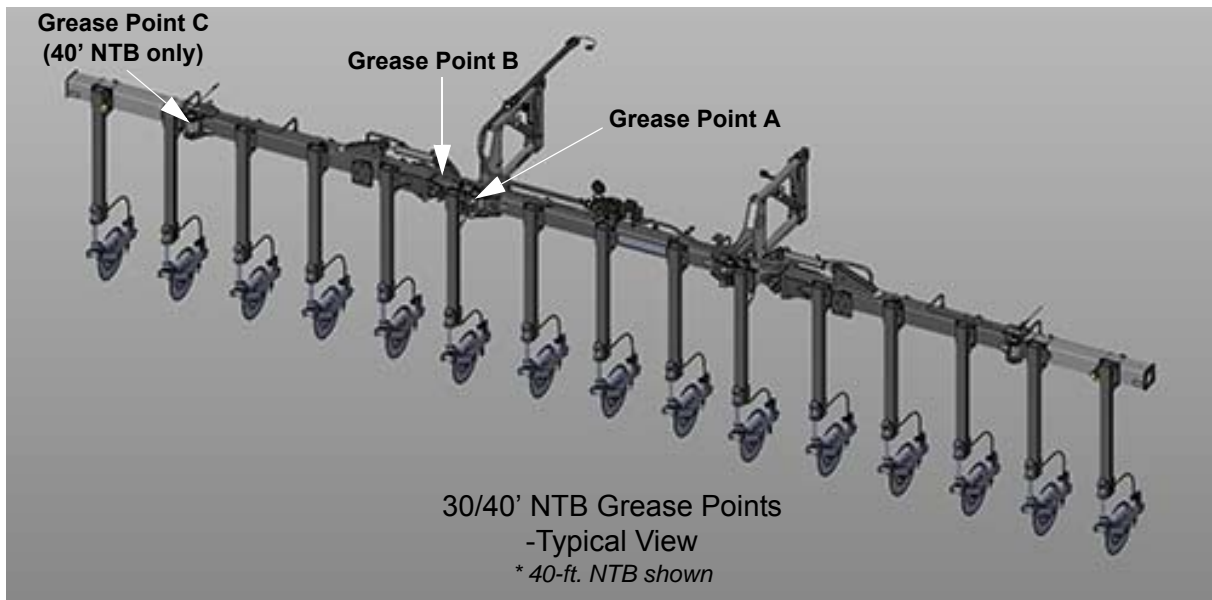

Grease Point A  
(Main Fold)

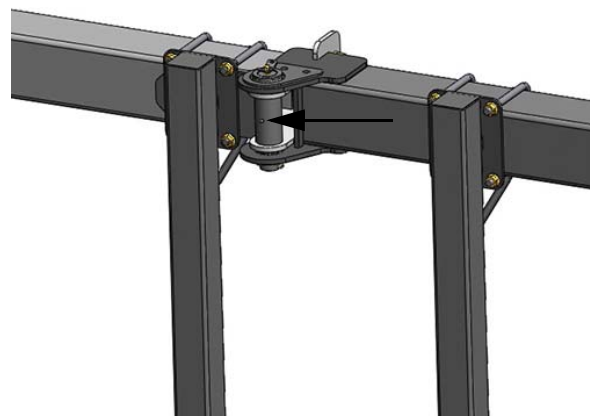

Grease Point C  
(Outer Fold)  
\* 40-ft. NTB only

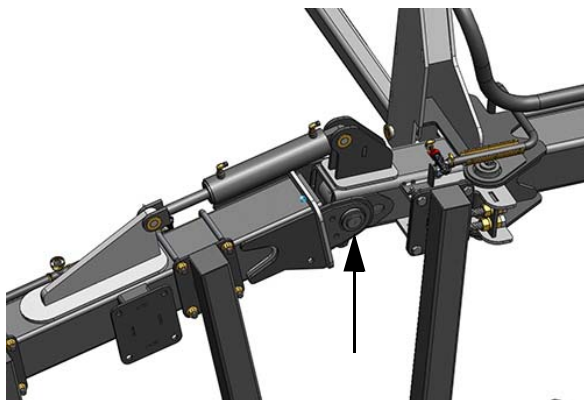

Grease Point B  
(Inside Fold)

## STORAGE

### Preparing For Storage

1. Perform lubrication and maintenance inspections, as required.
2. With the engine at normal operating temperature, cycle all hydraulic functions.
3. Thoroughly rinse the spray system.

*NOTE: Refer to your machine operator's manual for further information.*

4. Thoroughly wash the attachment and touch up any chipped or damaged paint.

5. Replace any damaged or missing decals.

*NOTE: Contact your local John Deere dealer for paint touch-up recommendations and decal replacement.*

6. Apply multi-purpose grease to hydraulic cylinder rods.
7. Refer to the spray system console manufacturer's operation manual for detailed information on monitor and flow meter storage procedures.
8. If the attachment will be stored separately, ensure that all open ends (e.g. hydraulic, electrical, solution, and foam marker - *if equipped*) are capped or covered with a suitable covering.

### **Winterization Procedure**

To winterize the NTB, it is recommended that you use an environmentally safe type of antifreeze and water mixture that will give you adequate protection to -30° F.

Drain any remaining solution in the system and rinse thoroughly. Run antifreeze mixture through the system until it comes out all attachment openings.

### **Removal From Storage**

1. Remove any dried grease from the cylinder rods and re-apply, if necessary.
2. Thoroughly clean the attachment.
3. Carefully unseal any openings that were sealed for storage.
4. Attach NTB to the sprayer and manually cycle the hydraulics two or three times to adequately lubricate components.



## SECTION 5 – MISCELLANEOUS

### TRANSPORTING

#### Transporting Your Machine with an Attachment

#### WARNING

- Never operate the sprayer on a public roadway with solution in the tank.
- Never load or unload the sprayer with solution in the tank.
- Stopping the sprayer on trailer ramps may result in the sprayer to tip over.

#### WARNING

- When transporting the sprayer, observe the following to avoid serious injury or death:
- Check for adequate clearance before driving under any overhead obstructions.
  - Contact with power lines may result in serious injury or death.

#### CAUTION

Ensure there is adequate clearance when transporting the sprayer near an object with clearance less than the transporting height and width of the overall machine and attachment.

#### CAUTION

Avoid collisions. Before transporting machine on a public roadway, check and follow local regulations regarding size limits, the use of lights, flags, signs, pilot vehicles, and other requirements for transporting loads using trailer.

#### CAUTION

Ensure the NTB is in the fully folded position before transporting the machine. Failure to comply may result in injury and/or property damage.

#### CAUTION

DO NOT operate the machine at speeds exceeding 20 mph (32 km/h) with solution in the tank. Operating speeds exceeding 20 mph (32 km/h) with a fully loaded tank may result in tire blow-out or wheel hub damage and will void the warranty.

### GAUGE WHEEL ADJUSTMENT

#### Storage to Field Position

1. Ensure the NTB is in the RAISED position.
2. Remove the two (2) Cotter Pins (located on the side of the gauge wheel mounting plate) and set aside.
3. Remove the two (2) Clevis Pins (located on the side of the gauge wheel mounting plate) and set aside.

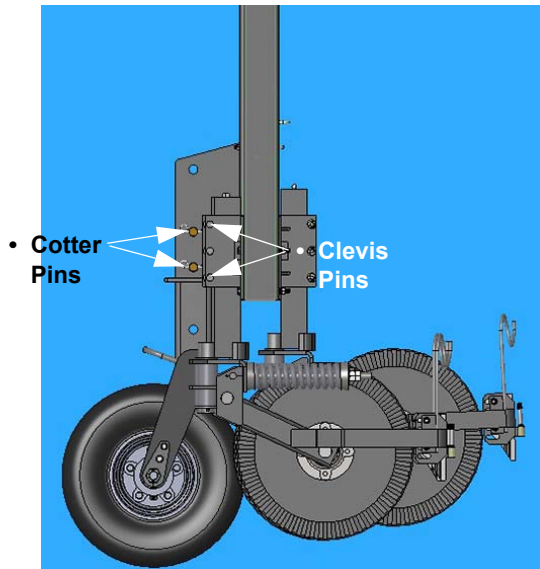

Cotter/Clevis Pin Assembly  
(Located on the side of the  
gauge wheel mounting plate)  
-Typical View

4. Firmly grasp the Lift Handle (located above gauge wheel) and lift gauge wheel UP.

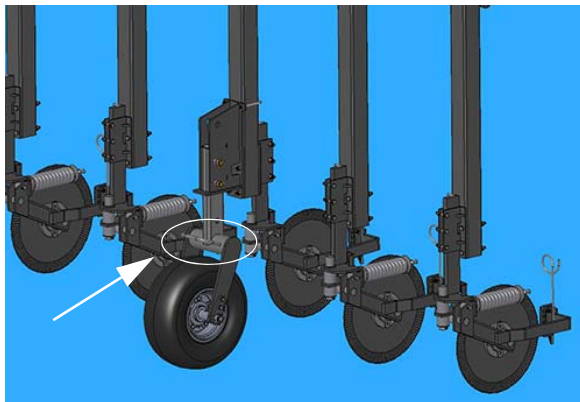

Lift Handle  
(Located above gauge wheel)  
-Typical View

5. Align holes and reinstall previously removed Clevis Pins and Cotter Pins into the top and bottom holes.
6. Repeat steps for additional gauge wheels.

### Field to Storage Position

Reverse previous steps to lower the gauge wheels to storage position.

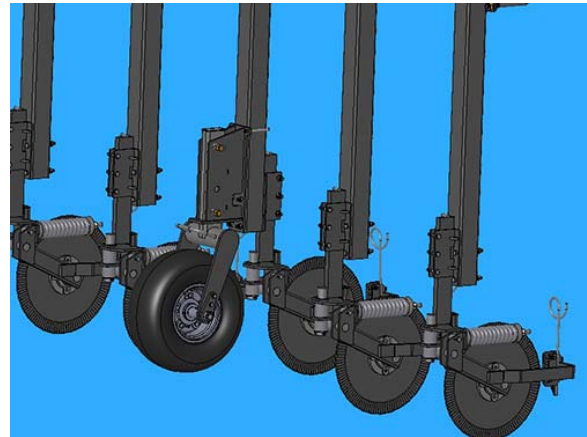

Gauge Wheel  
(Field position shown)  
-Typical View

## COULTER ADJUSTMENT

### Adjusting Coulters Spring Tension

When the coulters are not engaging the ground properly, the coulters springs may need to be compressed to apply down pressure.

- Using a wrench or socket, loosen or tighten Adjustment Nut (located on the end of each coulters spring).
  - Loosen nut for less down pressure.
  - Tighten nut for more down pressure.



Adjustment Nut  
(Located on the end of each coulters spring)  
-Typical View

## Adjusting the Coulters

- Loosen the three (3) Mounting Bolts (located on the side of the coulters mounting plate).



Mounting Bolts  
(Located on the side of the  
coulters mounting plate)  
-Typical View

- Raise or lower coulters to desired height.
- Re-tighten the Mounting Bolts.
- Repeat steps on additional coulters.

## QUICK-TACH SYSTEM

### Connecting the NTB

#### WARNING

When connecting or disconnecting the attachment, observe the following safety precautions:

- Monitor both sides of the attachment during fold procedure.
- Select a safe area that is solid and level before unfolding/folding the attachment.
- Clear area of personnel.
- Check for overhead obstructions.
- Do not unfold or fold attachment near power lines. Contact with power lines can result in serious injury or death.

#### WARNING

Turn the engine OFF before connecting/disconnecting any hoses or electrical lines. Failure to comply may result in serious injury or death.

1. Square up to the NTB attachment.
2. Disengage the Quick-Tach Lock Assemblies by pulling the Lock Pin (located on the front left and right-hand side of machine) OUT as far as it will go until it is in the “lock-out” position.

*NOTE: “Lock-out” position prevents re-locking while attaching or detaching the NTB.*

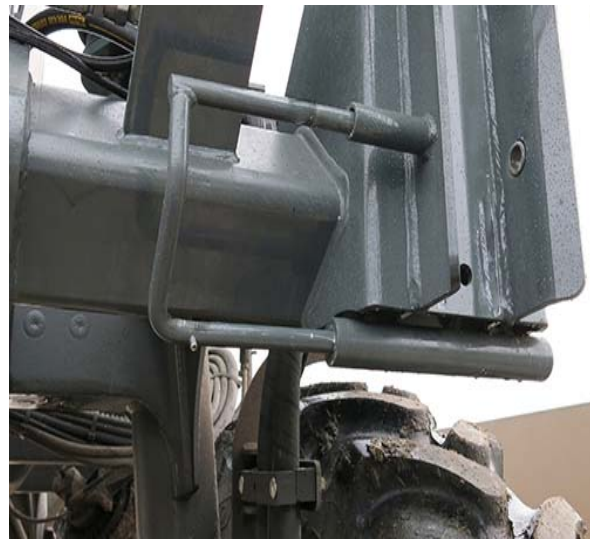

Lock Pin (2)  
(Located on the front left and  
right-hand side of machine)  
-Typical View

*\* Disengaged position shown*

3. Lower the machine by rotating the corresponding Air Suspension Valves (located on the left-hand front and rear air bags) in the COUNTER-CLOCKWISE (Deflate) position.



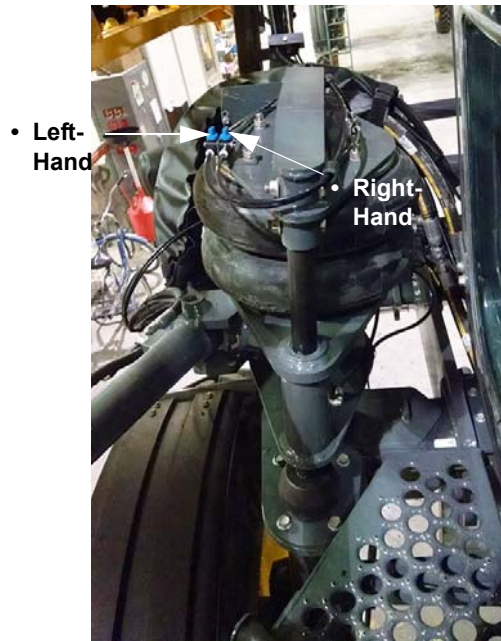

Air Suspension Valves  
(Located on the left-hand  
front and rear air bags)  
-Typical View  
*\* Front left-hand air bag shown*

4. Slowly pull machine into NTB attachment, ensuring the Attachment Hooks are high enough to clear the mounting pins.



Attachment Clearing Mounting Pins  
-Typical View

5. Raise the machine by rotating the corresponding Air Suspension Valves in the CLOCKWISE (Inflate) position.
6. Engage the parking brake.

7. Turn the engine OFF before connecting any hoses or electrical lines.
8. Connect all Solution, Foam Marker (if equipped), Hydraulic and Electrical Connections.

### Solution Connection



Solution Connection  
(Located on the front  
right-hand side of machine)  
-Typical View

## Foam Marker Connection

-If Equipped



Foam Marker Connection  
(Located on front  
right-hand side of machine)  
-Typical View

## Quick Connect Multi-Coupler

- Install the Hydraulic/Electrical Connections (located on the left-hand side of attachment) into the Multi-Coupler Receptacle (located on front left-hand side of machine), ensuring full engagement.
- Push the Quick Connect Handle (located on the Hydraulic/Electric Multi-Coupler Assembly) OUT to engage hydraulic/electrical connections.



Hydraulic/Electric Multi-Coupler Assembly  
(Located on the front  
left-hand side of machine)

9. Start the engine.
10. Raise the NTB attachment until the Attachment Hooks fully engage.

*NOTE: Raising the attachment will allow the weight of the NTB to pull the Attachment Hooks over the Mounting Pins. You will notice a change of weight as the machine begins to support the attachment.*



-Typical View

11. Engage the Quick-Tach Lock Assemblies by pushing the Lock Pins IN, ensuring full engagement.

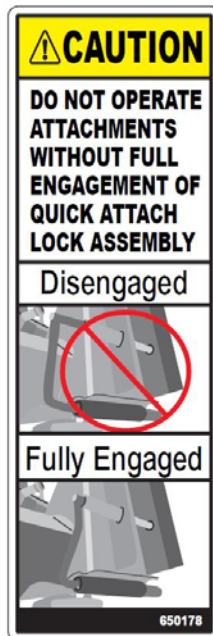

Lock Pin (2)  
-Typical View  
\* Engaged position shown

## Disconnecting the NTB

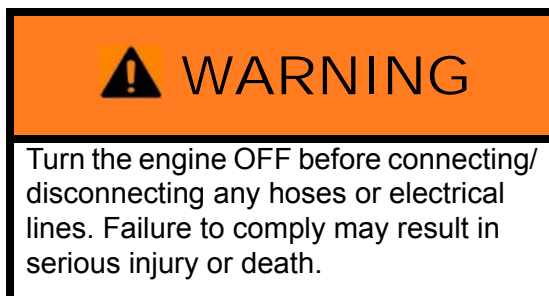

Before disconnecting the NTB, determine a proper storage location. When choosing a place to store the attachment, there are three important things to keep in mind:

### Is the ground level?

The ground must be level to help prevent the attachment from falling over. Level ground will also minimize stress on the frame of the attachment while in storage and ease of attachment hook-up.

### Is there enough space?

The NTB must be folded for it to stand properly. Be aware of the room that is needed for the attachment and adequate space to travel around it safely.

### Is it accessible?

The NTB must be positioned so you can connect the attachment easily. If temporarily storing the attachment on a soft surface (such as grass), it is recommended to put blocks or wood beneath the coulters to prevent the attachment from sinking into the ground.

*NOTE: It is NOT recommended to store the NTB attachment on a soft surface for an extended period of time, due to the risk of settling soil, even when blocks or wood are used.*

1. Lower the NTB attachment down to level storage location.

**! WARNING**

Lower NTB to the ground before disengaging the Quick-Tach Lock Assemblies.

2. Disengage the Quick-Tach Lock Assemblies by pulling the Lock Pin (located on the front left and right-hand side of machine) OUT as far as it will go until it is in the “lock-out” position.

*NOTE: “Lock-out” position prevents re-locking while attaching or detaching the NTB.*



Lock Pin (2)  
(Located on the front left and right-hand side of machine)  
-Typical View  
*\* Disengaged position shown*

3. Lower the machine by rotating the corresponding Air Suspension Valves (located on the left-hand front and rear air bags) in the COUNTER-CLOCK-WISE (Deflate) position.

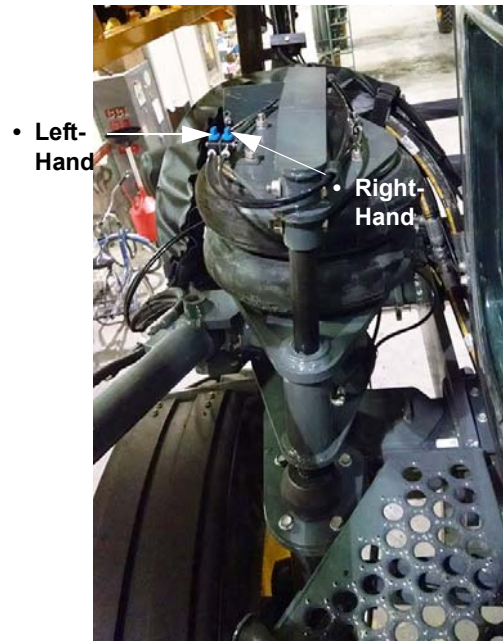

Air Suspension Valves  
(Located on the left-hand front and rear air bags)  
-Typical View  
*\* Front left-hand air bag shown*

4. Ensure the Boom Solution Valve Switches (located on the side console) are in the OFF position.



Boom Solution Valve Switches  
(Located on the side console)  
-Typical View

5. Engage the parking brake.
6. **Turn the engine OFF before disconnecting any hoses or electrical lines.**
7. Disconnect all Solution, Foam Marker (if equipped), Hydraulic, and Electrical Connections, ensuring not to leave the

ends in a place where they may become damaged or contaminated.

### Solution Connection



Solution Connection  
(Located on the front  
right-hand side of machine)  
-Typical View

### Foam Marker Connection

-If Equipped

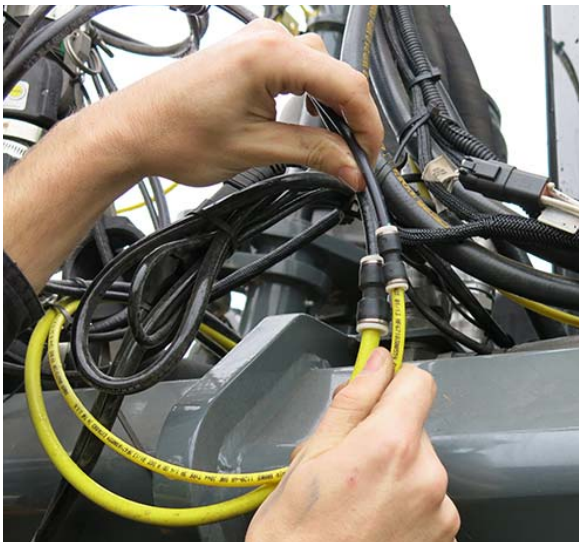

Foam Marker Connection  
(Located on front  
right-hand side of machine)  
-Typical View

### Quick Connect Multi-Coupler

- Push the Quick Connect Handle (located on the Hydraulic/Electric Multi-Coupler Assembly) IN to disengage hydraulic/electrical connections.
- Remove the Hydraulic/Electrical Connections from the Multi-Coupler Receptacle (located on front left-hand side of machine).



Hydraulic/Electric Multi-Coupler Assembly  
(Located on the front  
left-hand side of machine)

8. If no other attachment is going to be installed, re-lock the Quick-Tach Lock Assemblies by pushing the Lock Pins IN.



Lock Pin (2)  
-Typical View  
\* Engaged position shown

*NOTE: Install provided covers/caps on disconnection points to avoid damage and contamination. If necessary, cover the opening with a*

*plastic bag (secured with tape).  
Contact your local John Deere dealer  
for replacement covers.*

9. Start the engine.
10. Disengage the parking brake and slowly back away from the attachment.



-Typical View

11. Raise the machine by rotating the corresponding Air Suspension Valves in the CLOCKWISE (Inflate) position.



## INDEX

---

A Word From Hagie Manufacturing	
Company .....	1-1
About This Manual .....	1-1
Application .....	3-10
Coulter Adjustment .....	5-2
Float Operation .....	3-7
Fold Procedure .....	3-3
Gauge Wheel Adjustment .....	5-1
Intended Use .....	2-1
Lighting - Attachment Headlights .....	3-1
Product Warranty .....	1-2
Quick-Tach System .....	5-3
Safety Decals .....	2-3
Safety Messages Used In This	
Manual .....	1-2
Safety Precautions .....	2-1
Service - Lubrication .....	4-1
Service and Assistance .....	1-2
Specifications .....	1-3
Storage .....	4-2
Transporting .....	5-1

