

CALIFORNIA

Proposition 65 Warning

WARNING: Diesel engine exhaust and some of its constituents are known to the State of California to cause cancer and birth defects or other reproductive harm.

WARNING: Battery posts, terminals, and related accessories contain lead and lead compounds, chemicals known to the State of California to cause cancer and birth defects or other reproductive harm.



ANY PICTURES CONTAINED WITHIN THIS OPERATOR'S MANUAL THAT DEPICT SITUATIONS WITH SHIELDS, GUARDS, RAILS, OR LIDS REMOVED ARE FOR DEMONSTRATION PURPOSES ONLY. HAGIE MANUFACTURING COMPANY STRONGLY URGES THE OPERATOR TO KEEP ALL SHIELDS AND SAFETY DEVICES IN PLACE AT ALL TIMES.

HAGIE

MODEL STS 10



OPERATOR'S MANUAL FOR HAGIE MODEL STS 10 HI-TRACTOR

HAGIE MANUFACTURING COMPANY

BOX 273 CLARION, IOWA 50525

(515) 532-2861

COVERS MACHINE SERIAL NUMBERS: U1610660001 thru U1610660100

10-05 493357

© 2005 Hagie Manufacturing Company. Clarion, Iowa USA

ABBREVIATIONS

A/C	AIR CONDITIONING	MAINT	MAINTENANCE
ACCUM	ACCUMULATOR	MIN	MINUTE
ADJ	ADJUST	M/F	MAINFRAME
ADPTR	ADAPTER	MPH	MILES PER HOUR
ALT	ALTERNATOR	MT	MOUNT
AMP	AMPERE	MTH	MONTH
APPROX	APPROXIMATELY	MTR	MOTOR
ASSY	ASSEMBLY	NO	NUMBER
AUX	AUXILIARY	OD	OUTSIDE DIAMETER
BRKT	BRACKET	POLY	POLYETHYLENE
BTTRY	BATTERY	PRESS	PRESSURE
C	CELSIUS	PRKNG	PARKING
CAL	CALIBRATION	PSI	POUNDS PER SQUARE INCH
CCA	COLD CRANKING AMPS	QT	QUART
CHEM	CHEMICAL	RAD	RADIATOR
cm	CENTIMETER	REC	RECOMMENDED
CYL	CYLINDER	REQ	REQUIRED
DIA	DIAGRAM	RPM	REVOLUTIONS PER MINUTE
DISPL	DISPLACEMENT	SEC	SECOND
EA	EACH	SERV	SERVICE
ELECT	ELECTRIC	SMV	SLOW MOVING VEHICLE
F	FAHRENHEIT	SOLE	SOLENOID
FIG	FIGURE	SOLU	SOLUTION
FRT	FRONT	SPEC	SPECIFICATION
FT	FOOT OR FEET	STRG	STEERING
GA	GAUGE	SQ	SQUARE
GAL	GALLON	TACH	TACHOMETER
GPA	GALLONS PER ACRE	TEMP	TEMPERATURE
GPM	GALLONS PER MINUTE	TERM	TERMINAL
GPS	GLOBAL POSITIONING SATELLITE	TRD	TREAD
HAL	HALOGEN	TT	TUBE-TYPE
HR	HOOR	TU	TUBELESS
HYD	HYDRAULIC	VAR	VARIABLE
HYDRO	HYDROSTATIC	V	VOLT
ID	INSIDE DIAMETER	VFC	VARIABLE FLOW CONTROL
IN	INCH	VLV	VALVE
INFO	INFORMATION	W/	WITH
Km/H	KILOMETERS PER HOUR	W/O	WITHOUT
L	LITER (DISPLACEMENT)	W	WEIGHT
l	LITER (LIQUID)	WD	WHEEL DRIVE
LB	POUND	WHL	WHEEL
m	METER	WK	WEEK

TO THE OWNER



A WORD FROM HAGIE MANUFACTURING COMPANY

Congratulations on your selection of a Hagie Model STS 10 sprayer. We recommend that you study this Operator's Manual and become acquainted with the adjustments and operating procedures before attempting to operate your new sprayer. As with any piece of equipment, certain operating procedures, service, and maintenance are required to keep it in top running condition.

We have attempted herein to cover all of the adjustments required to fit varying conditions. However, there may be times when special care must be considered.

Hagie Manufacturing Company reserves the right to make changes in the design and material of any subsequent sprayer without obligation to existing units.

We thank you for choosing a Hagie sprayer and assure you of our continued interest in its satisfactory operation for you. If we might be of assistance to you, please call us.

We are proud to have you as a customer.

CAUTION

READ OPERATOR'S MANUAL. BE ALERT. LEARN TO OPERATE THIS MACHINE SAFELY. OBSERVE ALL SAFETY PRACTICES. MACHINES CAN BE HAZARDOUS IN THE HANDS OF AN UNFAMILIAR, UNTRAINED, OR COMPLACENT OPERATOR. SHUT OFF ENGINE BEFORE SERVICING. WHEN MECHANISM BECOMES CLOGGED, SHUT OFF ENGINE BEFORE CLEANING. DON'T RISK INJURY OR DEATH.

TO THE OPERATOR

The following pages and illustrations will help you operate and service your new sprayer. It is the responsibility of the user to read the Operator's Manual and comply with the safe correct operating procedures and lubricate and maintain the product according to the maintenance schedule.

The user is responsible for inspecting the machine and having parts repaired or replaced when continued use of the product causes damage

or excessive wear to other parts.

Keep this manual in a convenient place for easy reference when problems arise. This manual is considered a permanent fixture with this machine. In the event of resale, this manual should accompany the sprayer. If you do not understand any part of the manual or require additional information or service, contact the Hagie Customer Support Department:

Hagie Manufacturing Company
Box 273, Clarion, IA 50525
(515) 532-2861

The following symbols, found throughout this manual, alert you to potentially dangerous conditions to the operator, service personnel, or the equipment.



This symbol indicates a hazardous situation which, if not avoided, will result in death or serious injury.



This symbol indicates a potentially hazardous situation which, if not avoided, could result in death or injury.



This symbol indicates a potentially hazardous situation which, if not avoided, may result in minor or moderate injury. It may also be used to alert against unsafe practices.

TABLE OF CONTENTS

I.	SAFETY/DECALS.....	4-12
II.	SPRAYER IDENTIFICATION.....	13-14
III.	SPECIFICATIONS.....	15-19
IV.	OPERATING INFORMATION.....	20-53
V.	CALIBRATION.....	54-55
VI.	TRANSPORTING.....	56-57
VII.	SERVICE AND MAINTENANCE.....	58-81
VIII.	STORAGE.....	82-83
IX.	TROUBLE SHOOTING.....	84-92
X.	LIMITED WARRANTY.....	93
XI.	INDEX.....	94-95

I. SAFETY/DECALS

SAFETY PRECAUTIONS

Most accidents occur as the result of failure to follow simple and fundamental safety rules. For this reason, most accidents can be prevented by recognizing the real cause and doing something about it before the accident occurs.

Many conditions cannot be completely safeguarded against without interfering with efficient operation and/or reasonable accessibility. Therefore, you must study this Operator's Manual

and learn how to use the sprayer controls for safe operation. Likewise, do not let anyone operate without instruction.

Do not make modifications such as weldments, add-ons, adaptations, or changes from the original design of sprayer. Such changes and/or modifications may become safety hazards to you and to others and will void all warranties.

DRIVING

- Before moving sprayer, make sure no persons or obstructions are in path of travel.
- Do not permit passengers on sprayer when it is moving; they may fall off or obstruct operator's view.
- Never drive near ditches, embankments, holes, mounds, or other obstacles.
- Never drive on hills too steep for safe operation.
- Always drive at a reasonable field speed.
- Reduce sprayer's speed before turning.
- Come to a complete stop before reversing direction.
- Pull over to side of road before stopping.
- Additional weight caused from partially full or full solution tanks may cause erratic or increased stopping distance.
- Never operate sprayer on roadway with any solution in solution tank.
- Do not activate parking brake while machine is in motion or damage may occur to sprayer.
- Use flashing/hazard warning lights when traveling on public roads, day or night, unless prohibited by local law.
- Make sure SMV emblem is in place and visible from rear when traveling on public roads.

I. SAFETY/DECALS



TREAD WIDTH

- Select widest tread setting to fit between crop rows.

SPRAYER BOOMS

- Cradle booms when leaving sprayer unattended.
- Make sure booms are folded when cradled.
- Select a safe area before unfolding booms. Avoid power lines and overhead structures.

GENERAL OPERATION SAFETY

- Do not adjust factory engine RPM settings.
- Operate engine at recommended RPMs to assure proper charge pressure for hydrostatic drive system which controls braking performance.
- Start engine from operator's seat only. Do not by-pass safety-start switch.
- Never use starting fluid to assist engine start up.
- Never run sprayer engine in a closed building. Proper exhaust ventilation is required.
- If equipped with ground speed sensing radar, do not look directly into radar beam. It emits a very low intensity microwave signal which may cause possible eye damage.

I. SAFETY/DECALS

REPAIR/MAINTENANCE

HYDRAULICS

- Use caution when working with hydraulic fluid under pressure. Escaping hydraulic fluid can have sufficient force to penetrate your skin, causing serious injury. This fluid may also be hot enough to burn.
- Always lower load or relieve hydraulic pressure before repairing a hydraulic oil leak.
- Avoid torching, welding, and soldering near pressurized hydraulic lines.

FUELING

- Always turn engine off and allow it to cool before refueling.
- Do not smoke while refueling.
- Do not fill fuel tank completely. Fuel may expand and run over.

GENERAL REPAIR/MAINTENANCE

- Turn off engine before checking, adjusting, repairing, lubricating, or cleaning any part of sprayer.
- When servicing radiator, let engine cool before removing pressurized cap.
- Disconnect battery ground cable or turn main battery switch off before servicing electrical system or welding on machine.
- When charging battery, connect positive cable to positive terminal and negative cable to negative terminal. Failure to do so may result in an explosion and cause injury. Likewise, avoid battery acid contact and incurring injuries.

I. SAFETY/DECALS

CHEMICAL HANDLING

- Never allow chemicals to come in contact with skin or eyes. Wear protective clothing or respirators as recommended by chemical manufacturer. Store this clothing outside cab so as not contaminate filtered cab environment. Also, clean your boots to remove soil or other contaminated particles prior to entering cab.
- Never pour chemicals into an empty tank, fill tank half full of water first.
- Follow chemical manufacturer's instructions for mixing chemicals.
- Dispose of empty chemical containers properly.
- Wash spilled chemicals or spray residue from sprayer to prevent corrosion and deterioration.
- Select a safe area to fill, flush, calibrate, and clean sprayer where chemicals will not drift or run off to contaminate people, animals, vegetation, or water supply.
- Never place nozzle tips or other parts to one's lips in an attempt to unclog spray tip.
- Do not spray when wind is in excess of chemical manufacturer's recommended speed.
- Store pesticides in their original containers with label intact. Keep them in a separate, locked building.

GENERAL SAFETY

- Keep a fire extinguisher close at all times.
- Keep all shields in place.
- Keep clear of all moving parts and keep others away when operating.
- Do not wear loose fitting clothing that may be blown or drawn into moving parts.

WARNING DECALS 

I. SAFETY/DECALS

WARNING DECALS

Decals warning you of avoidable danger are located on various parts of the sprayer. They are there for your personal safety and protection. DO NOT remove them. They will fracture upon attempted removal and therefore must be replaced.

Following are locations of important safety decals. Replace them if they are torn or missing. All

warning decals and other instructional Hagie decals or machine striping may be purchased through the Hagie Customer Support Department. To replace decals, be sure that the installation area is clean and dry; decide on exact position before you remove the backing paper.

DECAL LOCATION



650107



Rear of mainframe above booster terminals.



650113



Right side glass in cab.

I. SAFETY/DECALS



650118

On engine compartment, in front of air intake.

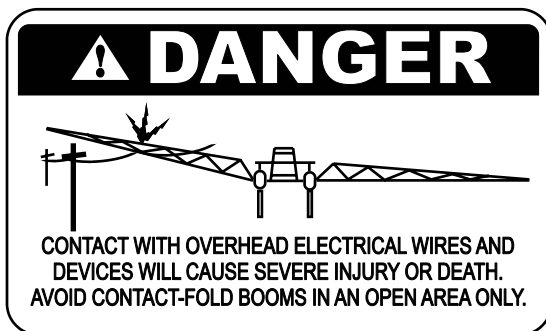

650337

Inside right-hand cab window, above controls.

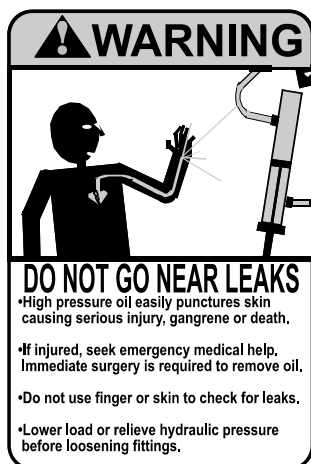

650339

On hydraulic reservoir, to left of sight gauge.

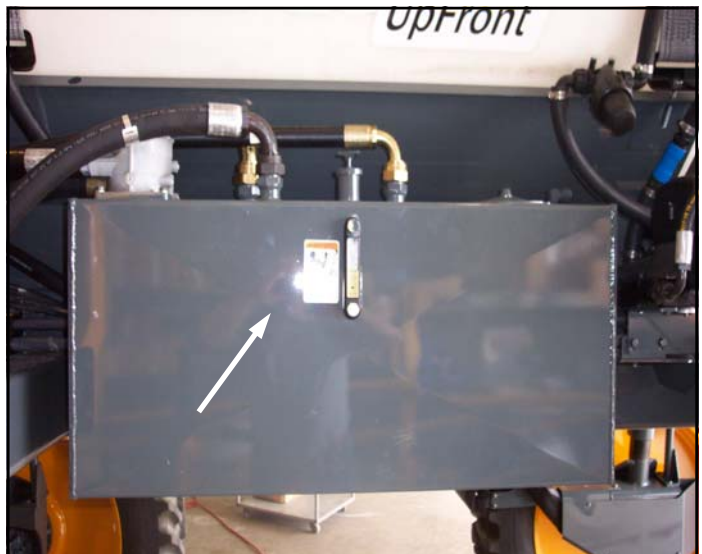

DECALS CONTINUED 

I. SAFETY/DECALS

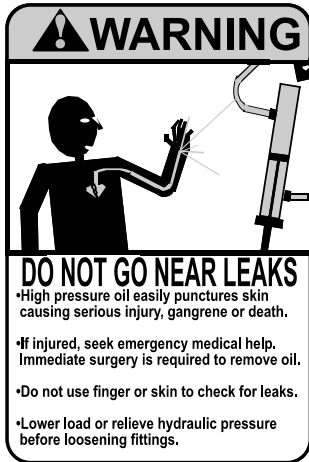

650339

On transom, near boom control manifold.

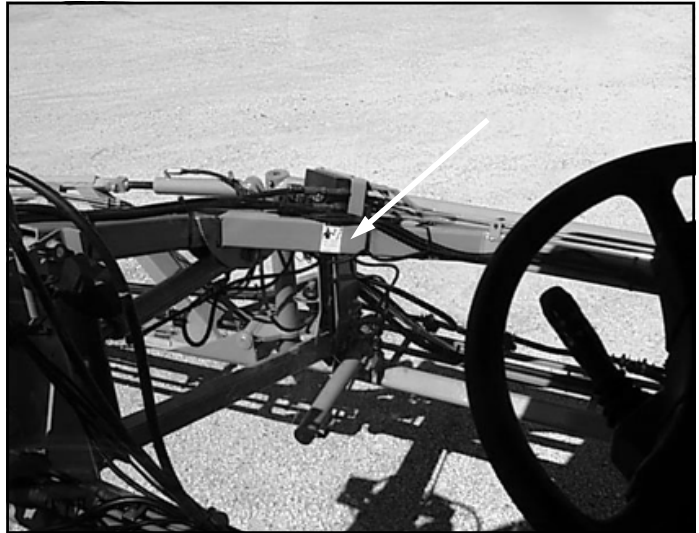

650340

On console above switches.



650848

On ladder pivot tube.



I. SAFETY/DECALS

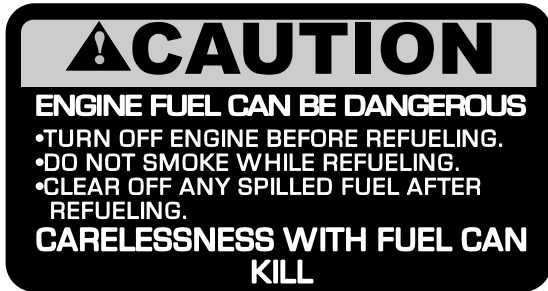

650849

On engine compartment, near fuel cell cap.

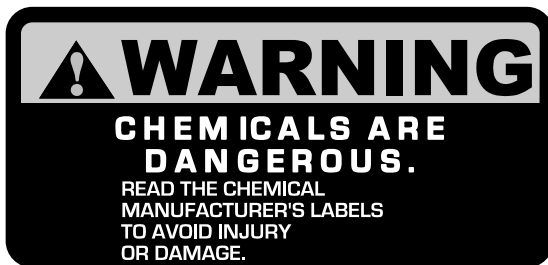

650850

On solution tank, near fill lid.



650851

Right rear mainframe.



DECALS CONTINUED

I. SAFETY/DECALS



650852

Above left door handle, inside cab.

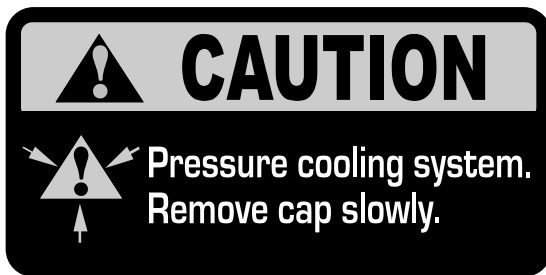

650981

In engine compartment, near radiator cap.

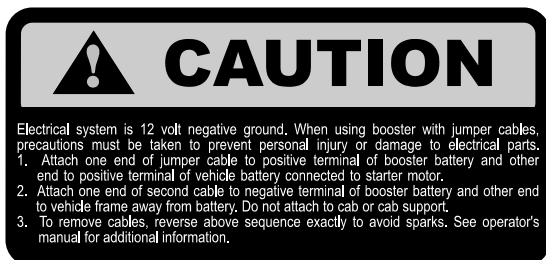

650982

Above top battery.



II. IDENTIFICATION NUMBERS

SPRAYER IDENTIFICATION

Each Hagie sprayer is identified by means of a frame serial number. This serial number denotes the model, year in which it was built, and the number of the sprayer. For further identification, the engine has a serial number, the hydrostatic pumps have serial numbers, the wheel motors have identification tags, and the planetary hubs have

identification plates that describe the type of mount and gear ratio. To ensure prompt, efficient service when ordering parts or requesting service repairs from Hagie Manufacturing Company, record the serial and identification numbers in the space provided below.

NOTE:

Reference to left-hand and right-hand used throughout this manual refers to the position when seated in the operator's seat facing forward.

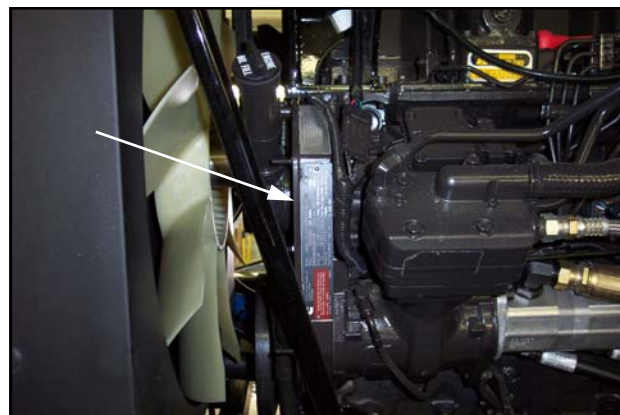
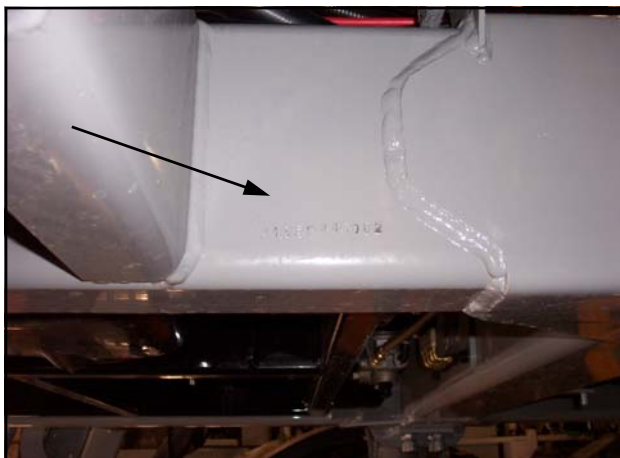

Sprayer

NOTE: Sprayer serial number stamped in the frame on right rear corner and metal tag on frame by ladder.

Engine

NOTE: Diesel engine serial number located on gear housing under A/C compressor.

II. IDENTIFICATION NUMBERS

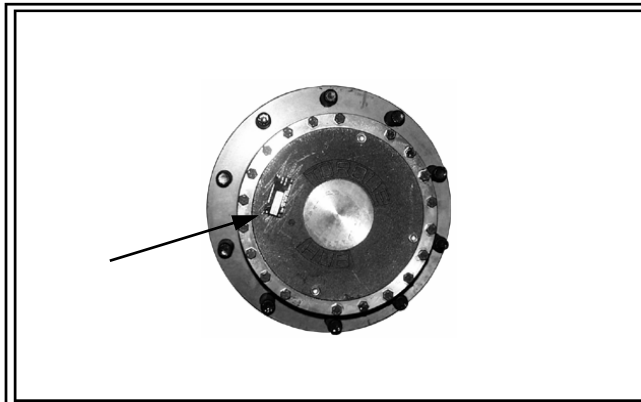

Planetary Hubs

Left

Right

Front: _____

Rear: _____

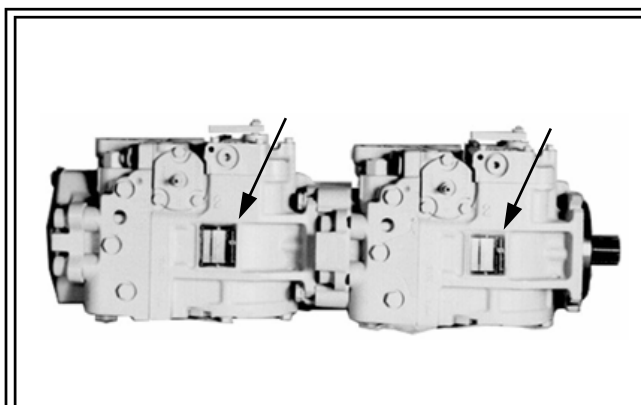

Hydrostatic Pumps

Front: _____

Rear: _____

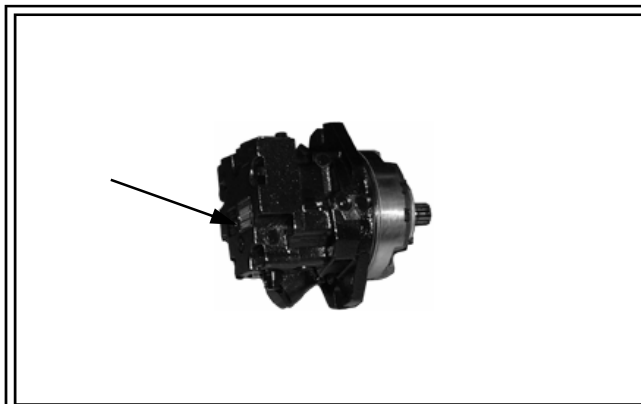

Front Wheel Motors

Left: _____

Right: _____

Refer to parts manual.

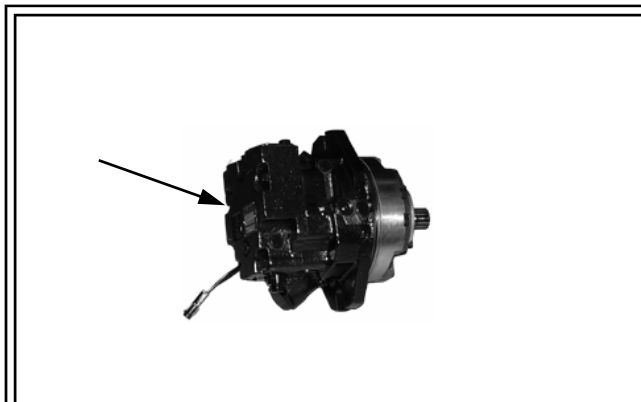

Rear Wheel Motors

Left - w/
Sensor: _____

Right - w/o
Sensor: _____

Refer to parts manual.

III. SPECIFICATIONS

SPRAYER DIMENSIONS

- | | | | |
|----------------------------------|---------------------|---|--------|
| A. Overall tractor height | 149" | E. Wheel base | 140" |
| B. Raised transom height..... | 142.5" | F. Sprayer length to engine rear..... | 311.5" |
| C. Transom lift range..... | 20-105" (85" range) | G. Sprayer length to booms folded | 318" |
| D. Static loaded hub height..... | 33.5" | | |

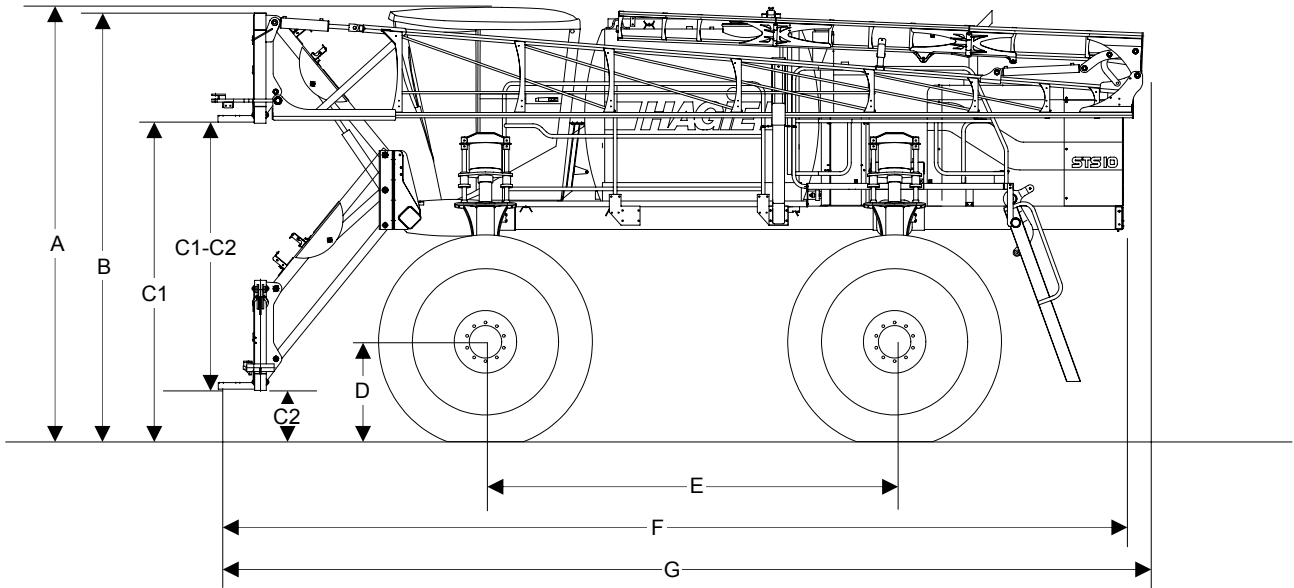

- | | |
|---|---------------------------|
| H. Width (booms folded, 120" tread)..... | 143" |
| I. Frame clearance | 72" |
| J. Lower leg clearance | 27" (rear) |
| K. Tire center to inside of lower leg | 13.5" (rear) |
| L. Tread width* | Adjustable
120" - 152" |

*NOTE: Measure tread width at 1/2 tire height.

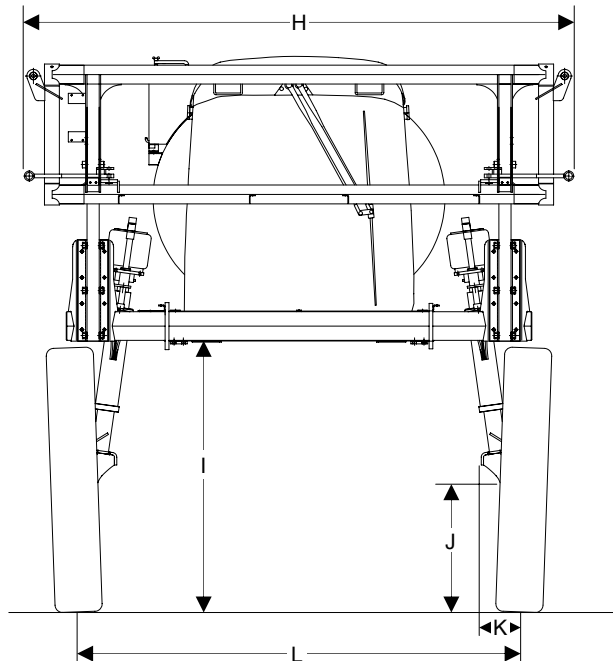

GENERAL SPRAYER INFORMATION

- | | | | |
|--------------------|--------------------------------|-------------------------------|------------|
| ◆ Frame type | 4 x 8 " modular platform frame | ◆ Approximate dry weight..... | 18,630 lb. |
| ◆ Suspension | 4-wheel, ind., auto air-ride | ◆ Shipping width | 143" |

III. SPECIFICATIONS

ENGINE

Manufacturer and model	Cummins
Model	QSB5.9-220
Type	Electronic with air to air cooler and turbocharger
Number of cylinders	6
Displacement	5.9 liter (360 c.i.)
Power	220 hp (205 kW), intermittent
Type of fuel	Number 1 or number 2 diesel
Fuel system	Filtered, direct-injected
Air cleaner	Dry-type, single element
Engine air filter restriction monitor.....	Filter Minder®
Slow idle.....	800 RPM
Fast idle.....	2500 RPM (no load)

POWER TRAIN

Drive

Hydrostatic pump	Sauer-Danfoss Tandem 90 series
Range.....	150cc (75 X 2) pressure compensated with electronic displacement control
Drive train.....	All-time four wheel drive
Speed - Low	0-14 mph (0-22.5 km/h)
- Medium	0-18 mph (0-29.0 km/h)
- High	0-30 mph (0-48.5 km/h)
Hydrostatic wheel motors- front and rear	Sauer-Danfoss (90 series)
Final drives	
Type	Planetary gear reduction hubs
- front and rear	Torque Hub® CW12
Lubrication	Oil bath

Brakes

Type	Multiple disc Spring applied Hydraulically released
------------	---

Steering System

Type	Hydraulic, dedicated circuit
Control.....	Full-time power
Steering cylinders.....	Self-centering, double action
Turning radius (120" tread setting).....	18 ft. (5.5 m)

III. SPECIFICATIONS

AUXILIARY HYDRAULIC SYSTEM

Type Open
Pump type Tandem gear

SPRAY SYSTEM

Booms

Type Dry, with variable row spacing(optional wet)
Standard 60/80/90 ft. (5 spray sections)
Controls Electro-hydraulic: fold/lift/level
Level shock absorber Gas-charged accumulator
Outer boom tip hydraulic breakaway Self-actuated, auto-reset hydraulic

Solution Fill Connection

Quick-fill connection 3 in. (7.6 cm) I.D.

Solution Tank

Standard 1000 gal. (3785 l) polyethylene w/sight gauge
Optional 1000 gal. (3785 l) stainless steel w/sight gauge
Agitation (polyethylene tank) Eductor-type w/elect. var. speed control
Agitation (stainless steel tank) Sparge-type w/elect. var. speed control

General Spray System

Pump Centrifugal - hydraulically driven with variable speed control
Solution valves Electric ball valves
Pressure gauge 100 PSI glycerin filled
Monitor Raven 4600 (GPS-ready)
Fence row nozzle Two position, remote activated

FOAM MARKING SYSTEM

Make Hagie Foam Marker
Type Live air

RINSE SYSTEMS

Spray system rinse (solution tanks, pump, and booms) Standard
High pressure washing system Optional

III. SPECIFICATIONS

ELECTRICAL SYSTEM

General Electrical System

Battery.....	Dual 12V, negative ground
Alternator.....	130 AMP, voltage regulated
Starter	12V with solenoid

Circuit Breakers/Fuses (See Model STS 10 Parts Manual.)

Lights

Front of cab	4 Trapezoidal field lights and 2 head lights
Transom mount.....	2 Trapezoidal head lights
Boom cradle (forward).....	2 Trapezoidal work lights (1 each)
Boom cradle (rearward)	2 Trapezoidal work lights (1 each)

CAB AND INSTRUMENTS

Cab

General cab.....	Tilt steering Windshield wiper/washer Dual side mirrors Dome light Tinted glass Training seat
Temperature control.....	Full-range
A/C charge type	R-134a
Fresh air filtration	Paper and charcoal filter
Seat.....	Air ride

Instruments

Message center.....	Hour meter Fuel Water temperature Battery voltage Engine oil pressure Ground speed Engine RPM Tread adjustment assist
---------------------	--

Stereo.....	AM/FM/WB with CD
-------------	------------------

III. SPECIFICATIONS

TIRES

Tires (front and rear)

Standard.....	380/90R46 (Radial TU)
Air pressure	35 PSI (240 kpa)
Tire width	15.0 in. (381 mm)
Load capacity at 25 MPH (40.2 Km/H).....	7150 lbs. (3250 kg)
Overall diameter	72.7 in. (1847 mm)
Static load radius (suggested—will vary with load)	33.5 in. (851 mm)
Rolling circumference.....	219.0 in. (5563 mm)
Optional (narrow row crop).....	380/90R54 (Radial TU) (Titan 320-90)
Air pressure	35 PSI (517 kpa)
Tire width	12.6 in. (381 mm)
Load capacity at 75 MPH (40.2 Km/H).....	6800 lbs. (5987.5 kg)
Overall diameter	72.6 in. (2042.2 mm)
Static load radius (suggested—will vary with load)	33.8 in. (947.42 mm)
Rolling circumference.....	219.0 in. (6147 mm)
Optional (wide).....	580/70R38 (Radial TU)
Air pressure	23 PSI (160 kpa)
Tire width.....	23.1 in. (587 mm)
Load capacity at 25 MPH (40.2 Km/H).....	8550 lbs. (3875 kg)
Overall diameter	72.2 in. (1834 mm)
Static load radius (suggested—will vary with load)	32.4 in. (823 mm)
Rolling circumference.....	216.4 in. (5497 mm)

CAPACITIES

Solution tank	1000 gallons (3785 ℓ)
Fuel cell.....	150 gallons (530 ℓ)
Cooling system (including block, lines & radiator).....	18 gallons (68 ℓ)
Hydraulic oil (including tank, lines, filter & cooler).....	55 gallons (208 ℓ)
Rinse system tank.....	100 gallons (379 ℓ)
Foam marker tank.....	36 gallons (136 ℓ)
Engine oil (including crankcase, lines, filter & cooler).....	17 quarts (16 ℓ)
Torque Hub®	
Front (2).....	84 oz. (2.5 ℓ) each (approx.)
Rear (2)	62 oz. (1.8 ℓ) each (approx.)

IV. OPERATING INFORMATION

OPERATING THE ENGINE

Pre-operational Checks	Page Reference
1. Check the engine oil level. Do not operate the engine when oil is below the low mark on dipstick.	62
2. Check the coolant level in the radiator and the coolant overflow reservoir.	64-65
3. Check the hydraulic oil reservoir level.	62
4. Check cooling air intake screen.	68
5. Check engine drive belt.	74
6. Drain fuel/water separator.	70
7. Check the Filter Minder®.	67
8. Check for any oil or fuel leaks and correct if needed.	
9. Drain any water out of air tank daily.	79

Starting the Engine



IV. OPERATING INFORMATION



FIG 4.01

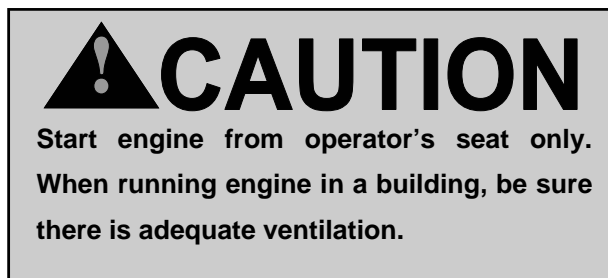

1. Position hydrostatic control lever to "N" (neutral) position.
2. Put the parking brake switch (fig. 4.01) to the "ON" position. (See page 24) . Turn the ignition key switch to the start position, wait for the wait to start light in the message center to go out (fig.4.02), to engage the starter. If the engine fails to start after 15 seconds, turn key to "OFF", wait one minute and repeat the procedure. If the engine does not start after three attempts, check fuel supply system. Absence of blue or white exhaust smoke during cranking indicates no fuel is being delivered.
3. Observe warning lights on message center (fig. 4.02) after start up.
4. If any functions do not operate, shut off engine and determine cause.
5. Always allow at least a five minute warm-up period before operating the engine at high RPM. This means the engine must reach operating temperature and oil pressure must stabilize in the normal operating range before it is run faster than an idle (1000 RPM or less).



FIG 4.02

NOTE:

Cold oil may not flow in quantities adequate to prevent pump cavitation.

IV. OPERATING INFORMATION



FIG 4.03



FIG 4.04



FIG 4.05

Operating Ladder

CAUTION

DO NOT lower ladder while anyone is on ground near sprayer. DO NOT attempt to lower ladder from ground level. Ladder may swing down quickly and strike others or operator.

To raise or lower the hydraulic ladder, locate the Park/Brake switch on the right-hand console (fig.4.05). By applying the Park Brake/Ladder switch, the ladder will lower automatically (fig.4.03), when engine is shut off. If the Park Brake/Ladder switch is pushed, the ladder will automatically raise when machine is running (fig.4.04).

CAUTION

Upright ladder is not service platform or step. DO NOT step on ladder while in upright position.

IV. OPERATING INFORMATION

HYDROSTATIC SYSTEM



FIG 4.06

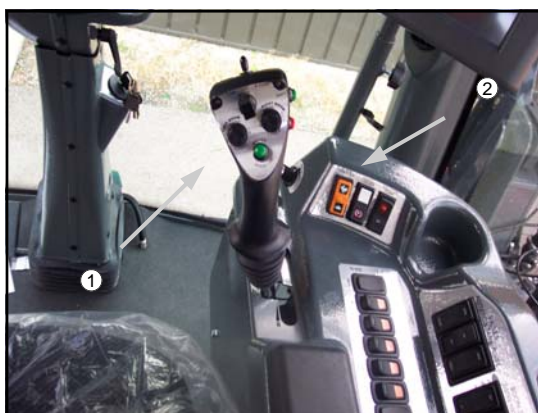

FIG 4.07



FIG 4.08

NOTE:

Machine will not shift down until highest speed of desired range is met.

Hydrostatic Drive

1. Speed ranges are selected by a red and green electronic switch mounted on the hydrostat handle (fig. 4.06,). The lower the setting, the higher the torque, but the lower the speed.
2. Increase engine RPM with the throttle switch (fig. 4.07, item 2) to the maximum recommended engine speed setting.

NOTE:

Never operate the sprayer at anything less than full recommended throttle.

3. To move forward, slowly push the hydrostatic control lever (fig. 4.07, item 1) forward. The farther the control lever is moved, the faster the sprayer will travel. To stop, slowly pull the lever to the “N” (neutral) position.
4. To reverse the machine, slowly pull the hydrostatic control lever back. To stop, slowly push the lever to the “N” (neutral) position.
5. Before turning off the engine, reduce engine speed and allow the engine to idle at least three minutes.

Cruise Control

The maximum speed of the hydrostatic control lever may be adjusted with the cruise control dial (fig. 4.08). This will conveniently help regain consistent field speeds when reentering a field from the end rows.

To set a cruise limit, start with the engine at maximum recommended throttle and cruise control dial all the way down (counterclockwise). Push the hydrostatic control lever all the way forward. Now turn the cruise control dial up while observing the ground speed and stop turning the dial when the desired field speed is reached. Now your maximum field speed is set and you simply reposition the handle all the way forward to regain that speed.

IV. OPERATING INFORMATION



FIG 4.08



FIG 4.09

Parking Brake

When the engine is shut off or if the charge pressure is below 150 PSI the brakes will become activated. To set the brakes while the engine is running, activate the switch located on the right-hand switch panel.

To engage the brakes, press the safety lock (fig. 4.08) on the switch down. While holding the safety lock down, depress the bottom of the switch (fig. 4.08). To release the brakes, depress the top of the brake switch (fig. 4.09). Always return the brake switch to the "OFF" position before moving the sprayer. Brake switch must be on to lower the ladder, and also to run the side fill or pressure washer.

NOTE:

The parking brake will not engage over 1 mile per hour.

IV. OPERATING INFORMATION

HYDRAULIC SYSTEM

The auxiliary hydraulic system is an open type directly mounted behind the heavy duty variable displacement pump and right side of engine. The systems consists of two dual gear pumps that supply the required hydraulics to operate the full time power steering unit, boom control cylinders

(lift, level and fold), tread adjust, ladder if equipped, outer boom breakaway and the solution pump.

After supplying each of these systems, the hydraulic oil is sent to the oil cooler at the rear of the engine compartment. Here it is cooled and then sent back to the hydraulic oil reservoir.



FIG 4.11

NOTE:

The red warning light (fig.4.11) will illuminate if the oil level in the hydraulic reservoir drops too low to safely operate the machine. If this occurs, you must shut down the engine immediately to prevent damage to hydraulic system.

NOTE:

The red warning light will illuminate when any fault is detected. An explanation of the fault will appear on the message center.

CAUTION

DO NOT GO NEAR LEAKS. High pressure oil easily punctures skin causing injury, gangrene, or death. If injured, seek emergency medical help. Immediate surgery is required to remove oil. Do not use finger or skin to check for leaks. Lower load or relieve hydraulic pressure before loosening fittings.

IV. OPERATING INFORMATION



FIG 4.12



FIG 4.13

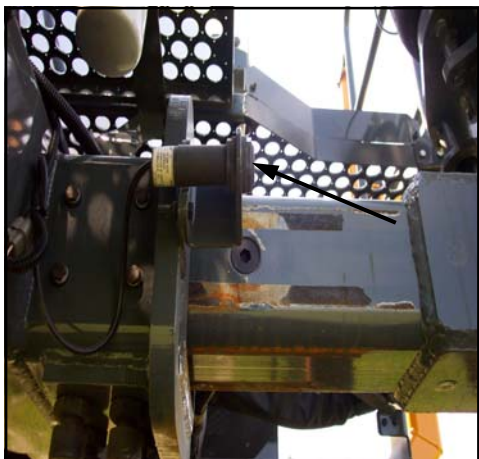

FIG 4.14

Operating the Hydraulic Tread Adjust

CAUTION

Never adjust the hydraulic tread on a public roadway. Make sure the sprayer is on level ground where there are no ditches or valleys to interfere when you perform the adjustment.

1. Survey the surroundings and allow yourself enough room to adjust tread either in forward or reverse.
2. Locate the tread adjustment switches on right-hand console (fig. 4.12). They are marked LF (left front), LR (left rear), RF (right front) and RR (right rear). The legs may be moved in or out on each side independently. While driving between one and two mph, press and hold the desired switches to move tread in the desired direction. Pressing the top of any switch will move that leg OUT and pressing the bottom of any switch will move that leg IN.
4. Observe the tread width on each leg. Front legs use indicator decals (fig. 4.13) and rear legs use electronic sensors and the message center in the cab (fig. 4.14). See page 53 for information about message center. Release the switch when the tread indicator reaches the desired tread marking.
5. After adjustment is complete, all four tread width indicators should have identical readings.
6. To recalibrate toe-in: while driving forward slowly, turn the steering wheel all the way one way until the steering cylinder bottoms out; continue turning the wheel a little more to let fluid bypass the cylinder. Then turn the steering wheel all the other way and repeat the process. When wheels are then straightened, steering cylinders should be recentered and correct toe-in should be obtained (see page 76).

IV. OPERATING INFORMATION

Adjusting Tread Width Manually

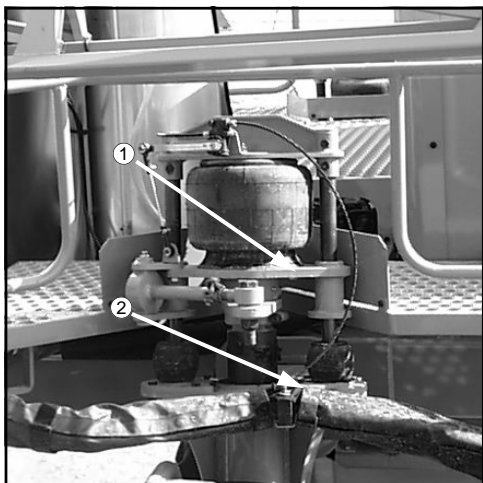

FIG 4.15



FIG 4.16

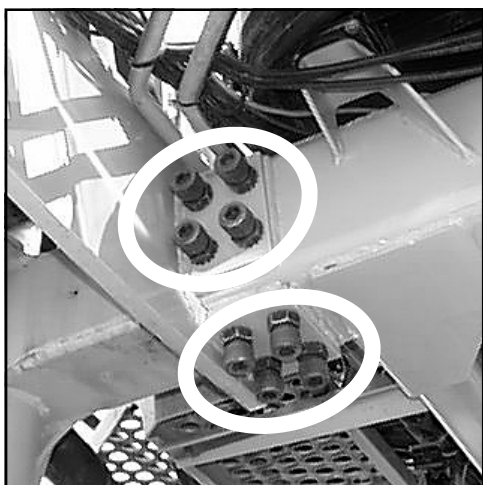

FIG 4.17

1. Empty solution from tank, turn off engine and set parking brake on level surface.
2. Chock all three wheels, front and back, that are not being adjusted.
3. Lock suspension up on the leg being adjusted with a solid block between points 1 and 2 (fig. 4.15).
4. After lifting with properly-rated overhead hoist or floor jack, position properly-rated jack stand under frame and lower sprayer onto stand (fig. 4.16). Remove floor jack if used. Tire of leg being adjusted should be approximately six inches off ground.
5. Loosen all eight tread adjust tension bolts on the leg to be adjusted (fig. 4.17) one turn each. Tension bolts should only be loosened, NOT removed. Do NOT remove or loosen any of the other three legs' tension bolts at this time.

CAUTION

Adjust the tread setting of only one leg at a time.

6. Slowly slide leg assembly to desired width. Use of a hand cable winch or other pulling tools may be required.
7. Retighten tread adjust tension bolts to 100 lb-ft of torque. See page 76 for additional tread adjust tension bolt information.
8. Lower leg and repeat previous steps until all four axles have desired tread width.

IV. OPERATING INFORMATION

SPRAY BOOMS

Hydraulically folding the extensions of the 60/80/90 foot boom system and adjusting spray valves essentially turns it into a 60 foot boom (see pages 32 & 37). Manually folding the outer extensions of the 60/80/90 foot system, adjusting spray valves and recalibrating spray monitor essentially turns it into an 80 foot boom (see pages 34 & 54).

The spray booms are controlled by an electro-hydraulic system. This system consists of operator manipulated switches located in the sprayer's cab and hydraulic cylinders attached to the booms. It provides

control of lift (page 29), level (page 30), horizontal fold (page 31) and vertical fold (page 32).

All STS 10 spray booms are equipped with a hydraulic breakaway circuit. When folded out as an 80 or 90 foot spray boom, a one-way hydraulic circuit on the outer boom section provides outer boom breakaway functions. The outer breakaway is self-resetting and will return to normal operating position after it has cleared the hazard.

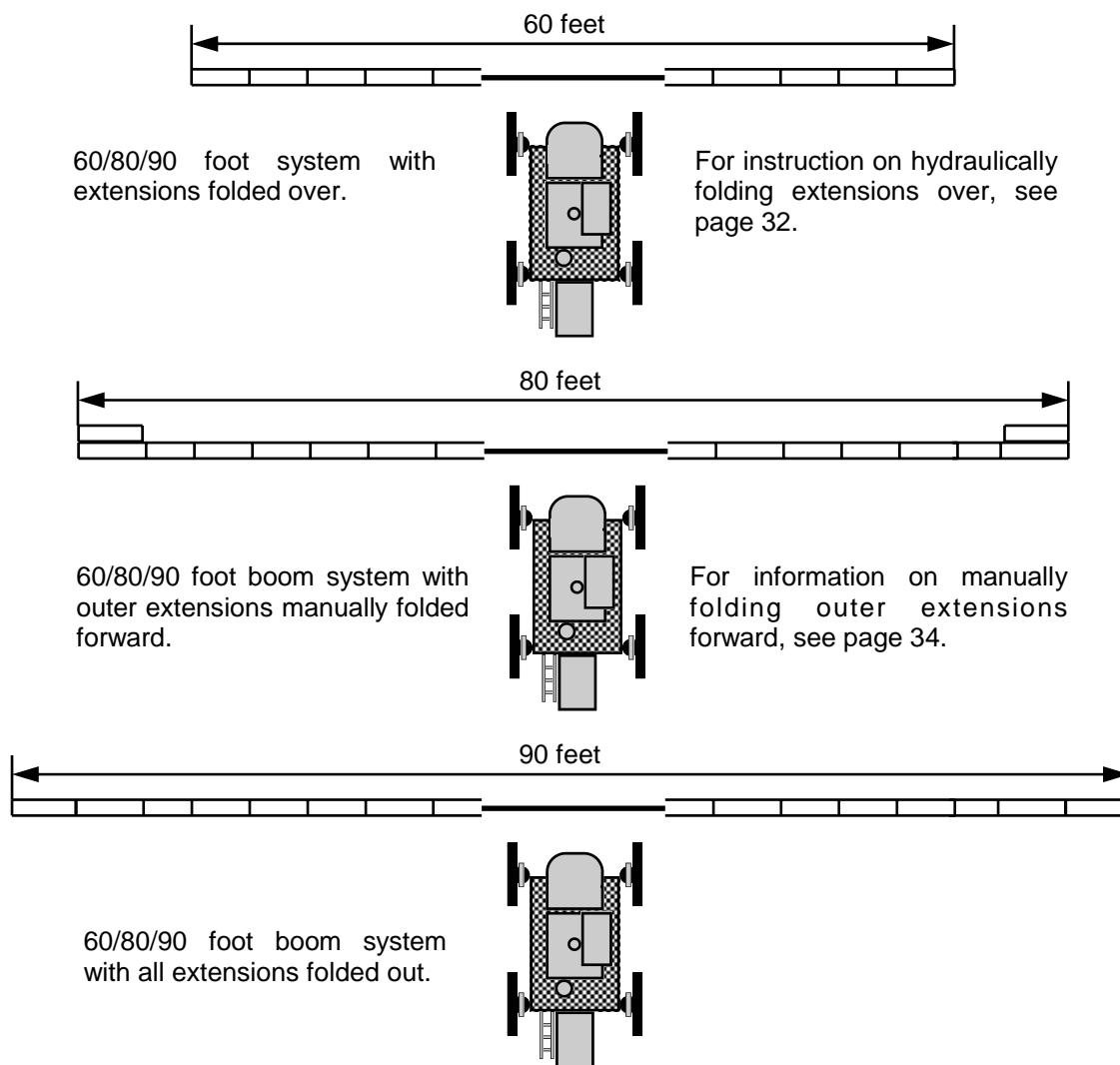

IV. OPERATING INFORMATION

Lift

To raise and lower the transom/boom assembly, depress the “Square Rocker” (UP) or the “Square Rocker” (DOWN) on the hydrostatic drive handle (fig. 4.19 item 1). While depressed, either button activates the transom lift cylinders (fig. 4.18).



FIG 4.18



FIG 4.19

NOTE:

See your spray tip manufacturer's guide for information regarding spray tip height (fig. 4.20).

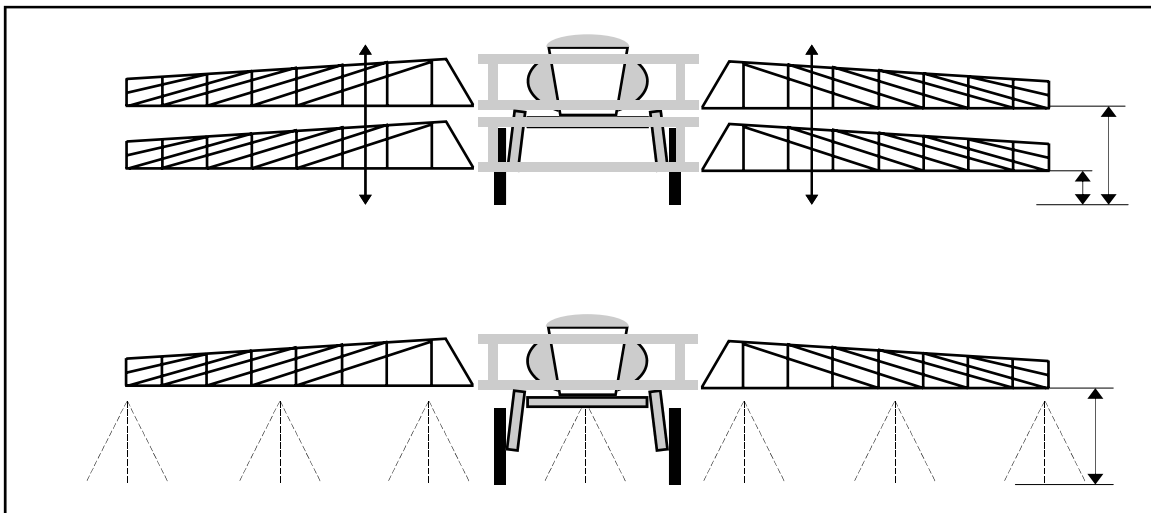

FIG 4.20

IV. OPERATING INFORMATION

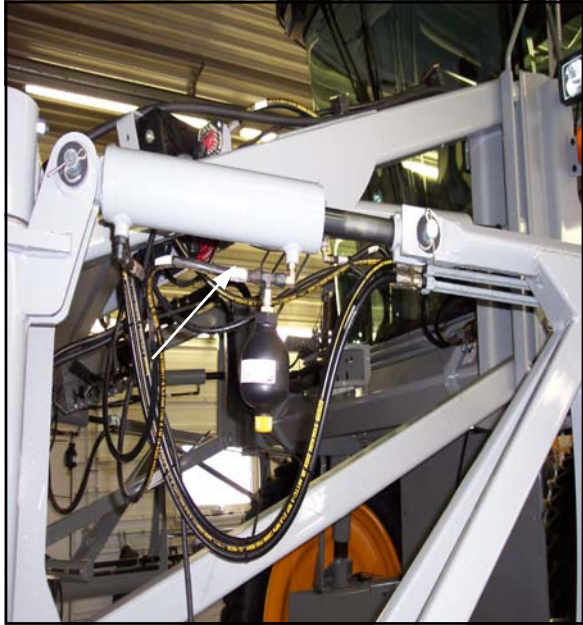

FIG 4.21

Level

To increase or decrease the angle of each individual boom level, depress the left or right “Round Rocker” (UP) or the left or right “Round Rocker” (DOWN) buttons on the hydrostatic drive handle (fig. 4.22, items 1 and 2). While depressed, these buttons activate the level cylinders connecting either boom to the transom (fig. 4.21).

This adjustment also aids in placing the booms correctly in the cradles for transporting and storing.

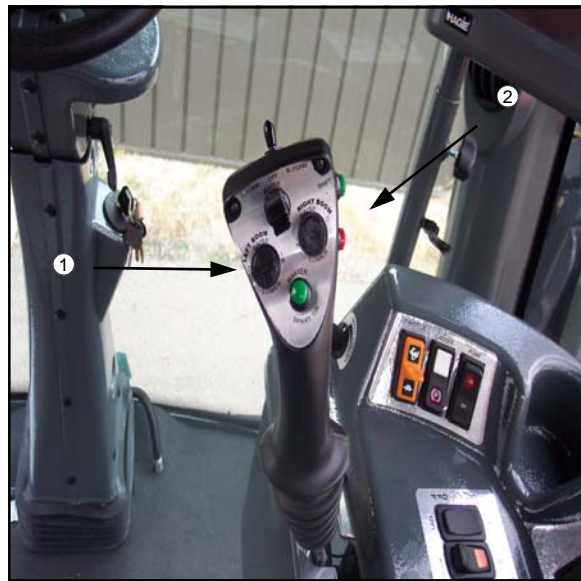

FIG 4.22

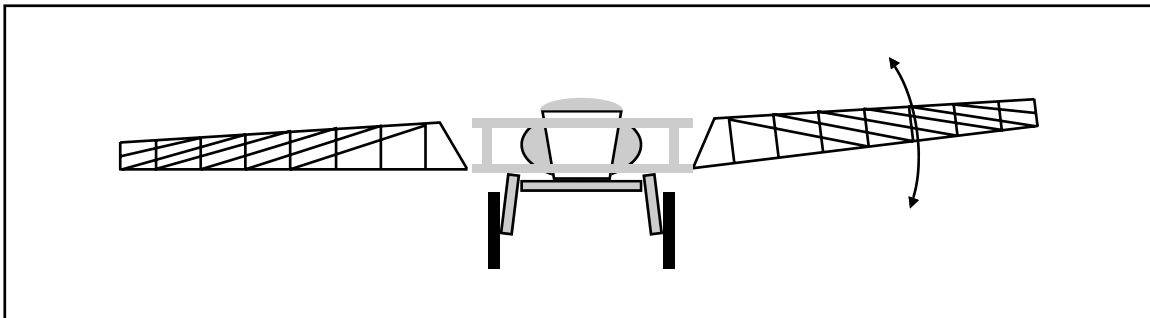

FIG 4.23

IV. OPERATING INFORMATION



FIG 4.24

Fold

HORIZONTAL BOOM FOLD - To fold either boom horizontally in toward the machine or out, depress the right or left Rocker “Boom Fold” switches on the hydrostat handle (fig. 4.25). While depressed, these switches activate cylinders connecting either boom to the transom (fig. 4.24).

Fold or unfold the booms in an open area only. Make sure no one is standing in the path of the boom fold’s travel path. Booms can be folded if speed is (5MPH).



FIG 4.25

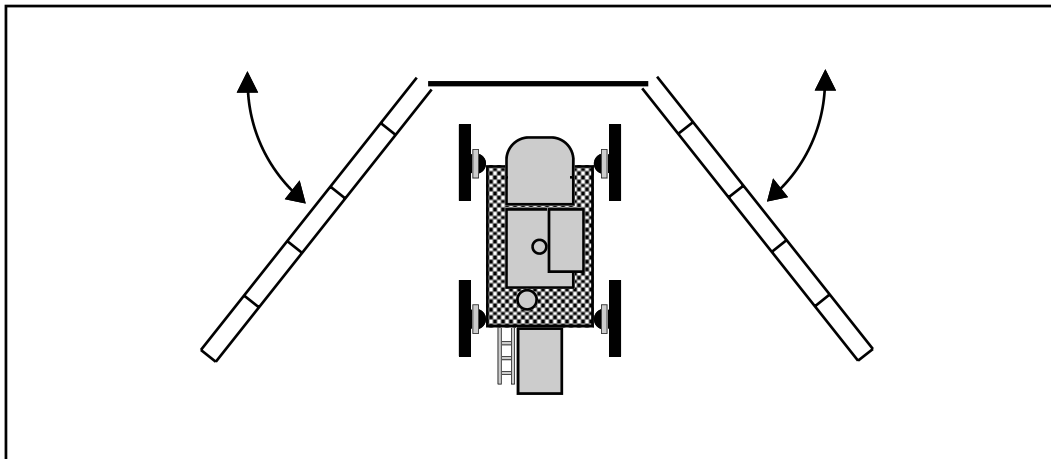

FIG 4.26

IV. OPERATING INFORMATION



FIG 4.27

Fold

VERTICAL EXTENSION FOLD - To fold the boom extensions vertically in or out, depress the top or bottom of the “ Boom Extension” switch (fig. 4.28). This activates both extension cylinders connecting the inner boom section and the center boom section (fig. 4.27).

Fold or unfold the booms in an open area only. Make sure there are no overhead obstructions or wires to interfere with extension folding.

NOTE:

Booms extensions can only be folded when hydrostatic control lever is in the neutral position, and you have pushed the (OK) in the message center showing you have acknowledged there are no power lines overhead. If sprayer is put in gear during folding, booms will stop.

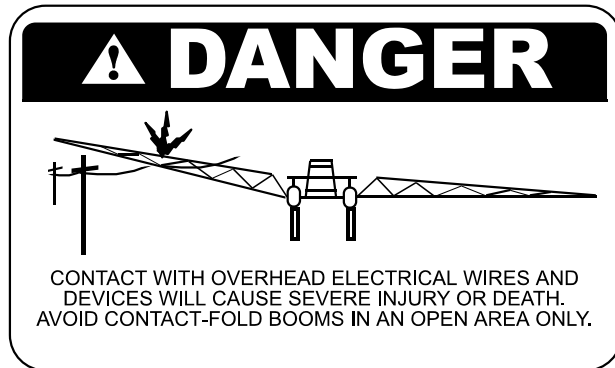

FIG 4.28

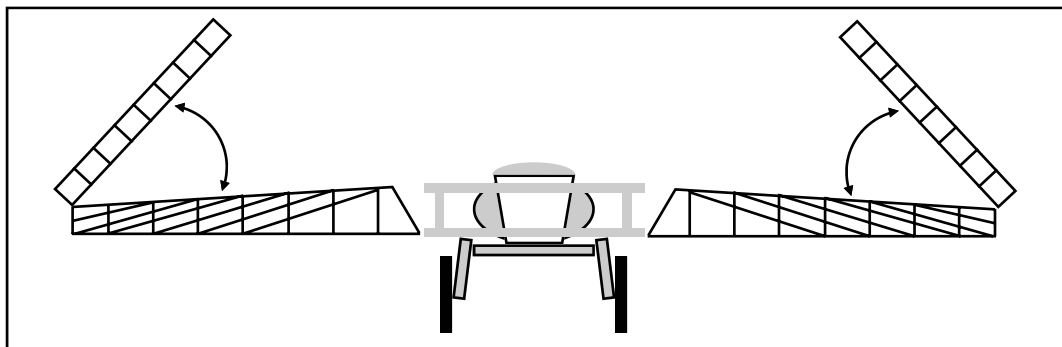

FIG 4.29

IV. OPERATING INFORMATION



FIG 4.30



FIG 4.31

Cradling Booms

The booms should always be cradled when traveling, transporting, or parking for an extended period of time. The booms must be folded when cradled. To cradle the booms, fold the boom extensions in, raise the transom, and fold the booms in toward the machine. When the boom reaches the last 8-10 degrees of travel towards the cradle, it will automatically slow down to avoid impact with cradle. Raise each individual boom level until it clears the outer cradle stop (fig. 4.30). Fold the boom in toward the cradle back-stop. When it touches the back-stop, lower the boom level until the full weight of the boom rests in the cradle (fig. 4.31).

NOTE:

Booms must be in folded position when cradled. Failure to do so may cause boom damage.

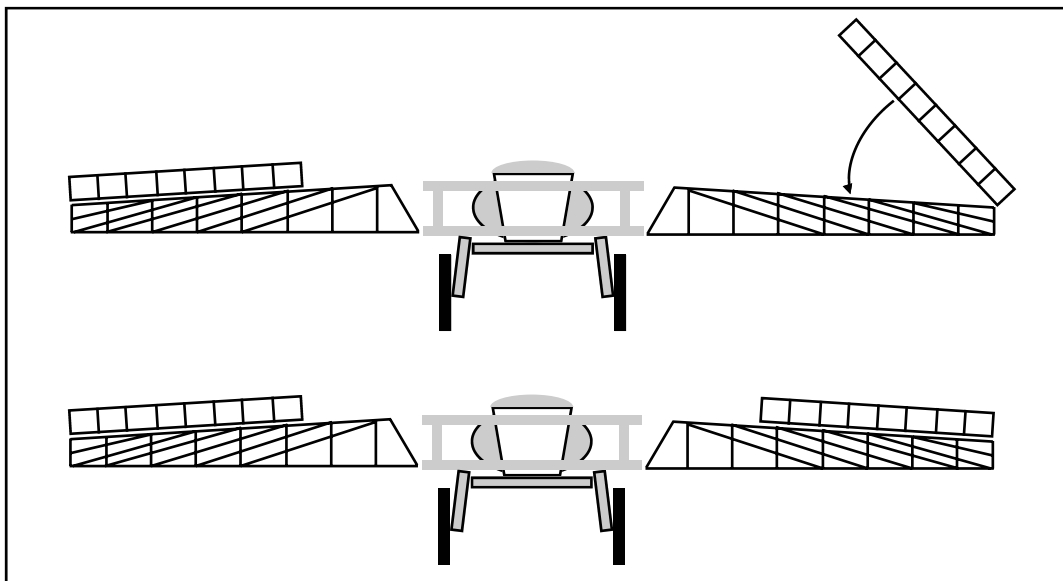

FIG 4.32

IV. OPERATING INFORMATION

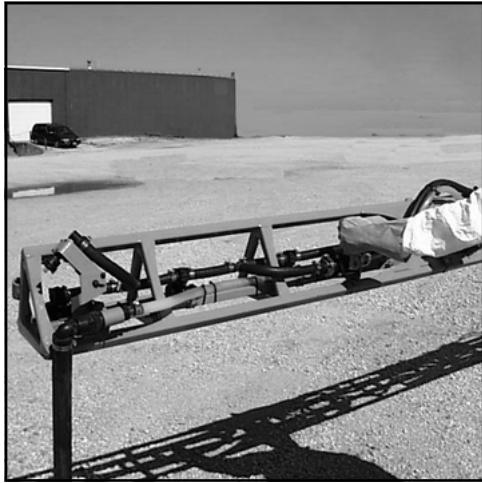

FIG 4.33

Folding 90' Boom to 80' Boom

To convert a 90 foot boom to an 80 foot boom, manually close the solution supply valve on the outer section (fig. 4.33). Remove the pin on the back side of the boom so it will hinge forward (fig. 4.34) and secure it with rear pin (fig. 4.35) Repeat these steps on the other side and recalibrate monitor accordingly (see page 54) before spraying resumes. See page 43 for information regarding foam marker width adjustment.



FIG 4.34



FIG 4.35

IV. OPERATING INFORMATION

SPRAY SYSTEM

The spraying system is a constantly-monitored and continuously-adjusted computer-controlled system. The cab-mounted digital monitor receives information from various inputs to help determine GPM (gallons per minute) and GPA (gallons per acre).

SPRAY SYSTEM OPERATION INSTRUCTIONS

OPERATION	PAGE REFERENCE
1. Calibrate spraying system monitor.	54
2. Check contents and quantity in spray tank.	
NOTE: Never attempt to operate the spray system without solution in the spray tank. Operating the spray system with no solution in the tank will cause severe damage and void the warranty.	
3. Start engine and maintain a relatively low engine RPM setting (1,000 RPM). Increase engine RPM slowly until full recommended operating RPM is reached.	20
4. If desired, activate the agitation system.	42
5. Turn on the solution pump switch.	36
6. Turn on main spray power.	38
7. Place individual boom solution valve switches to the "ON" position.	37
8. Slowly move the hydrostatic control lever forward to obtain the desired ground speed.	23
9. Frequently observe the pressure gauge. When it drops to zero, or spray pattern deteriorates, shut off main spray power, solution	36, 38, 36, 42, 40

IV. OPERATING INFORMATION



FIG 4.36

Solution Pump

To turn the solution pump (4.36) on, place the solution pump switch (fig. 4.37) to the “ON” position while at a relatively low engine RPM setting (1,000 RPM). Increase engine RPM slowly and maintain full recommended throttle RPM for field operation. When finished applying solution or if solution tank is empty, turn the solution pump switch to the “OFF” position.



FIG 4.37

Solution Pressure Gauge

The solution pressure gauge (fig. 4.38) gives the operator a constant visual display of the amount of solution being applied (measured in PSI). The pressure (as determined by the monitor-controlled variable flow control) will vary according to ground speed. If applying solution manually, the solution pressure gauge visually informs the operator of needed manual adjustments. Gauge also shows when there is a drop in pressure the solution tanks may be empty or a problem with the system.



FIG 4.38

NOTE:

DO NOT allow the pump to continue running when the boom switches are turned off (see page 37). Failure to do so will generate over-heating and cause severe pump damage and void the warranty.

IV. OPERATING INFORMATION



FIG 4.39A

Electric Solution Valves

The spray booms are divided into sections that are independently supplied with solution and can therefore independently be shut off or turned on. Sixty foot boom configurations are divided into three sections and the valves are mounted on the transom. Eighty and ninety foot boom configurations are divided into five sections with three valves mounted on the transom and one mounted on each boom.



FIG 4.39B

Boom Valve Switches

The electronic boom solution valves are controlled by a row of switches mounted on the right hand console (fig. 4.39A). The solution tank valve switch is also located on right hand console (fig.4.39B). Fig. 4.39C shows location of tank valve.

Boom Section L.E.D. Indicators

Boom solution valve status is displayed on the transom by a series of L.E.D. indicators (fig. 4.40). Each indicator will light up if that particular boom solution valve is turned “OFF.”



FIG 4.39C



FIG 4.40

IV. OPERATING INFORMATION



FIG 4.42



FIG 4.43A



FIG 4.43B

Main Solution Switch

Main spray power can be controlled from a switch mounted on the hydrostatic control lever (fig. 4.42). This switch controls the power supply to the panel of boom solution valve switches. The switch must be on to supply the switches with voltage. This way you can turn all of the boom solution valves “ON” or “OFF” all at once in a hands-free execution such as turning the main solution switch “OFF” as you arrive at the end rows of a field and turn it back “ON” as you enter the field again. This switch supplies the power to the boom solution valve switches that you turn off to disconnect the power.

When the main spray power is “ON” a “GREEN” indicator light mounted on the right side of the message center will light up (fig. 4.43A), also a white light mounted above boom lights on transom assembly (fig.4.43B), will come on. When the light is not lit, the main solution switch is “OFF.”

IV. OPERATING INFORMATION

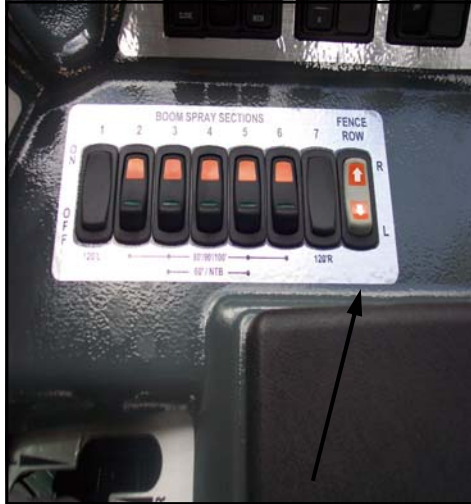

FIG 4.44

Fence Row Applicator

To operate the fence row nozzle, locate the fence row switch on the switch control panel (fig. 4.44). If you wish to turn on the right fence row nozzle, depress the top side of the fence row switch. If you wish to turn on the left fence row nozzle, depress the bottom side of the fence row switch. To turn either fence row nozzle off, return the fence row switch back to the center (“OFF”) position.

As you engage either fence row nozzle you may notice a drop in solution pressure.

A set of amber L.E.D. lights mounted on the transom on either side of the boom solution valve L.E.D. lights will inform the operator of fence row status. If the left fence row nozzle is on, the left amber L.E.D. light is lit (fig. 4.45, item 1). If the right fence row nozzle is on, the right amber L.E.D. light is lit (fig. 4.45, item 2). If neither amber L.E.D. light is lit, no solution is being applied through the fence row nozzles.

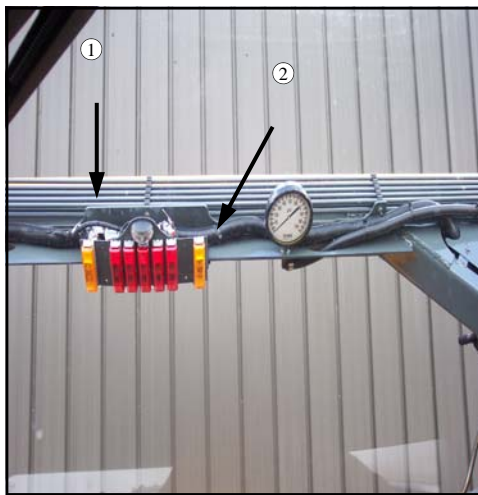

FIG 4.45

IV. OPERATING INFORMATION

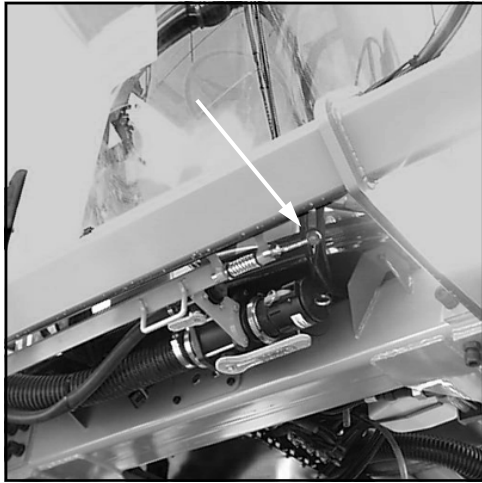

FIG 4.46

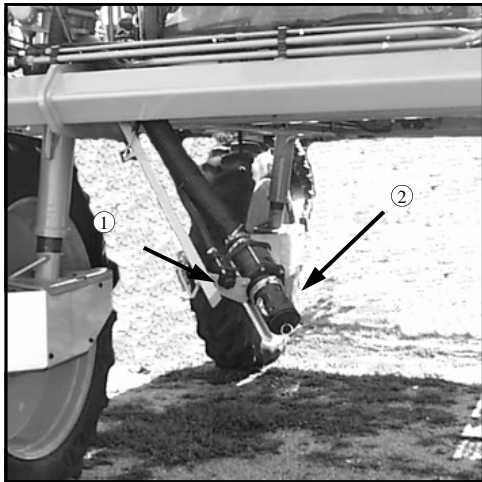

FIG 4.47



FIG 4.48

Solution Quick-Fill

To fill the solution tank, make sure the sump valve under the tank is open. To access the front fill, pull the front fill latch lever down and the assembly will lower (fig. 4.46). Connect it to your solution supply (fig. 4.47, item 2) and fill to the desired level. You may also fill the rinse tank from ground level (fig. 4.47, item 1) with owner supplied connection. When finished, shut the valves and return the front fill to the locked position. See the next page for information regarding the use of the side fill inductor (fig. 4.48) for filling the solution tank.

IV. OPERATING INFORMATION

Inductor Operation

With the engine running and the parking brake set, lower the inductor assembly with the inductor control box (fig. 4.49, item 2). If filling with the suck-on attachment, leave the engine running. If filling with the push-on attachment, turn the engine off.

NOTE:

The following fill and rinse scenarios refer to figure 4.50 below.



FIG 4.49

Load water only: B-connected, C- on, E-off, F-off.

Suck water only*: B-connected,C-on, E-off, F-off.

Load water/induct chem: B-connected, E-open, F-off.

Suck water/induct chem*: B-connected,E-open, F-off.

Fill rinse tank: A-handle perpendicular to sprayer.

Rinse inductor tank with rinse tank: F- valve on.

Rinse inductor tank with nurse tank (suck or load): F-valve on, E-valve on.

*To activate “suck-on” pump, flip the inductor control switch up (fig. 4.49, item 1). This will start the pump and increase engine speed. Flip switch down when filling is complete.

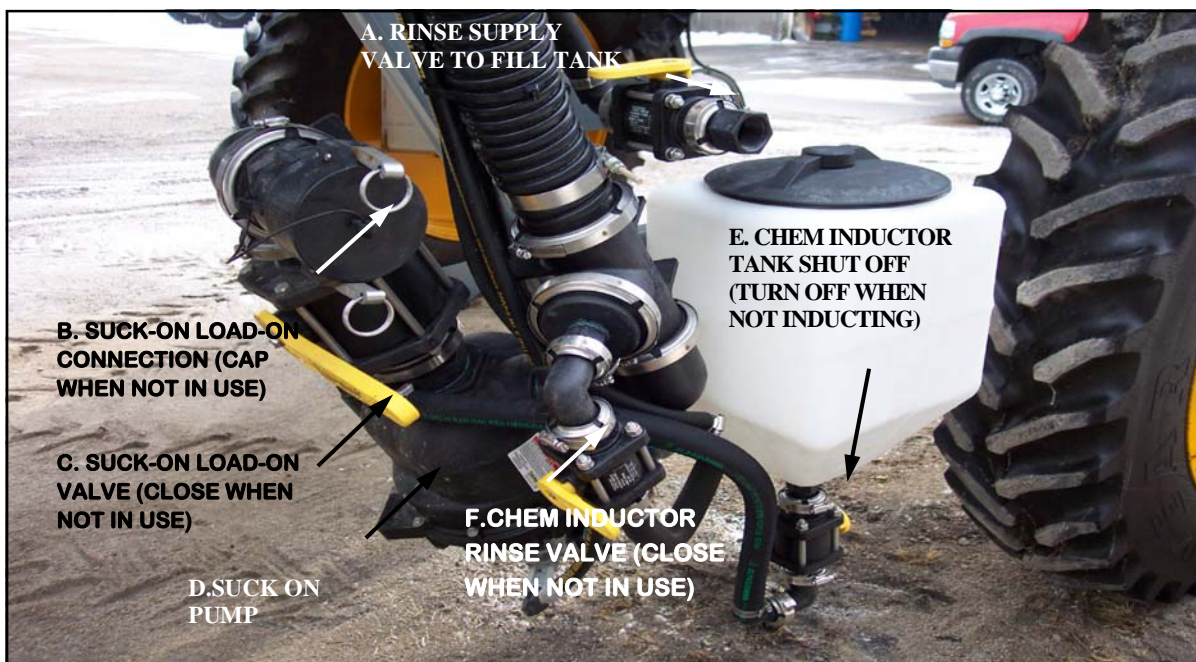

FIG 4.50

IV. OPERATING INFORMATION

AGITATION SYSTEM



FIG 4.51

The speed of the sparge agitation system is controlled by a variable flow solution valve mounted on the solution pump (fig. 4.51). The agitation switch (fig. 4.52) on the right-hand console controls the rate of flow through the sparge system. While watching the indicator on the sparge valve (fig. 4.53), increase or decrease the flow rate with the agitation control switch. Press up to increase flow rate and down to decrease it. When desired rate of flow is achieved, release the agitation switch.



FIG 4.52



FIG 4.53

IV. OPERATING INFORMATION

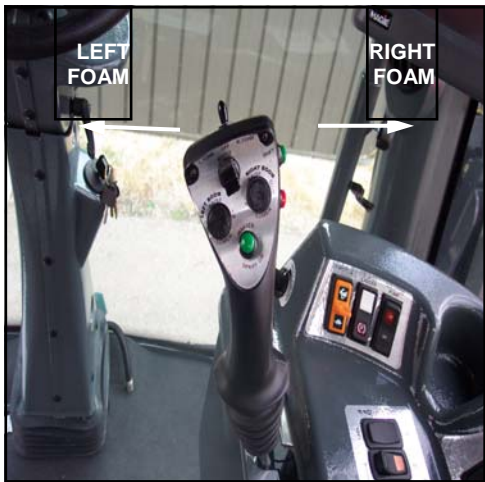

FIG. 4.54



FIG 4.55

Foamer Operation

To operate the foam marking system, locate the toggle switch on the top of the hydrostat control handle (fig. 4.54). Push the top of the switch left if foam is desired from the left foam drop. Push the top of the switch right if foam is desired from the right foam drop. Return the switch to the middle position if no foam is desired.

System pressure is indicated by a pressure gauge on the regulator which is mounted next to the foam tank (fig. 4.55). To adjust the air pressure in the foam tank, turn the knob on the regulator clockwise for more pressure, and counterclockwise for less pressure. To correctly decrease the pressure in the foam tank, you must first open either the left or right foam valve for a moment to relieve system pressure. Then adjust regulator accordingly.

See figure below for foam drop valve configurations.

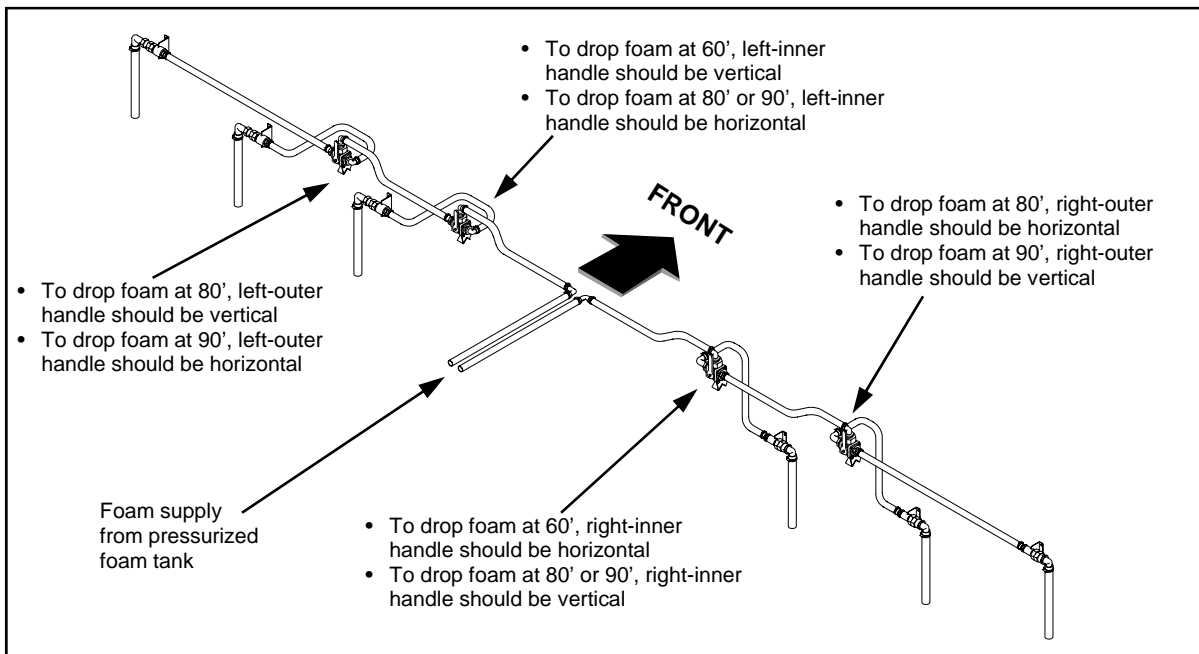

FIG 4.56

IV. OPERATING INFORMATION

Filling Foam Marker System

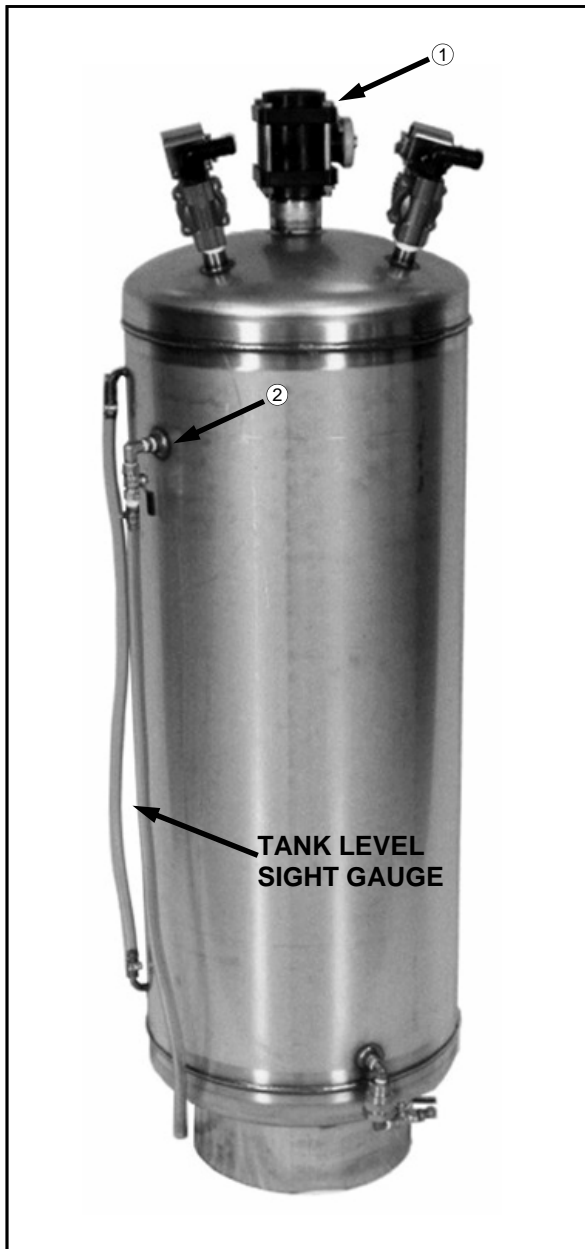

FIG 4.57

CAUTION

Before performing any service or refilling of the foam marker, shut the engine off and relieve system pressure from the tank.

WARNING

DO NOT stand directly over or in front of valves when opening.

Relieve pressure from the foam tank by opening the ¼" ball valve on the side of the foam tank (fig 4.57, item 2). Close the ball valve after pressure is relieved. Open the top 2" ball valve (fig. 4.57, item 1). Add water to the tank, leaving enough room for the foam concentrate. Next add the foam concentrate according to the label on the container. After filling is complete, close the 2" ball valve on top of the tank. Start the sprayer's engine and adjust the air pressure accordingly (see previous page).

IV. OPERATING INFORMATION



FIG 4.58



FIG 4.59

NOTE:

Select a safe area to rinse spray system and clean sprayer where the chemicals will not drift off to contaminate people, animals, vegetation, or water supply.

NOTE:

Refer to chemical manufacturer's guide for types of cleaning solution combinations (plain water, cleaning agents, etc.).

Rinse System Operation

NOTE:

Activate the rinse system only after solution tank is empty.

TO RINSE SOLUTION TANK AND 3" FILL LINES:

Solution pump switch should be in the "ON" position (fig. 4.58).

1. Turn on spray system monitor Turn the rate switch to the "MANUAL" position. Using the flow increase/decrease lever, increase solution pressure to maximum PSI.
2. Close the solution tank valve (fig. 4.59, item 2).
3. Depress the "SOLU TANK" rinse switch (fig. 4.59, item 3).
4. Momentarily activate and then deactivate agitation (fig. 4.59, item 1).
5. When finished rinsing the solution tank return the rinse switch back to the "OFF" position and turn the spraying system off (including solution pump switch, and monitor).

TO RINSE BOOM SUPPLY AND NOZZLES:

1. Follow steps 1 and 2 from above.
2. Turn agitation off (fig. 4.59, item 1).
3. Close solution tank valve (fig. 4.59, item 2) and open boom supply valves (fig. 4.59).
4. Depress the "BOOM" rinse switch (fig. 4.59, item 3).
5. When finished rinsing the boom return rinse switch back to the "OFF" position and turn the spraying system off (including solution pump switch, monitor, boom solution valves and main spray power switch).

IV. OPERATING INFORMATION



FIG 4.60

HAND WASH SYSTEM



Fill hand wash system tank (fig. 4.60) with fresh water only. The hand wash valve is located under the left side of the sprayer (fig. 4.61). Remember to close the valve before refilling.

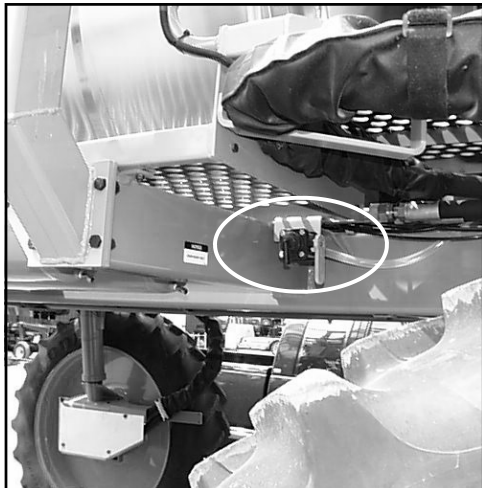

FIG 4.61



IV. OPERATING INFORMATION

LIGHTS



FIG 4.62

HIGHWAY LIGHTS - Mounted on the cab and on the transom mount is two each trapezoid driving lamps (fig. 4.64, item 1 and 2). Use these lights when traveling on a public road at night. Turn them on using the rocker switch on the steering pedestal (fig. 4.62).

FIELD LIGHTS - The front of the cab also houses four trapezoid field lamps (fig. 4.64, item 3). Use these lights when operating in a field after dark. Turn them on by pressing rocker switches located on the upper right cab headliner (4.65). Turn them off when entering a public roadway.

The highway or field lights are operational when the light switch is pushed in the up position (fig. 4.63). The ignition key does not have to be on in order to operate the highway lights but does have to be on to operate field lights. Extended use without the engine operating to charge the battery is not recommended.



FIG 4.63



FIG 4.64



FIG 4.65

IV. OPERATING INFORMATION



FIG 4.66

Work Lights

Additional work lights are located on each boom cradle (fig. 4.67, items 1 & 2), one on each side facing forward and one on each side facing backward. Use these lights when operating in a field after dark. Turn them on by pressing the rocker switch (fig. 4.66). To turn them off, press rocker switch down. Turn them off when entering a public roadway.

The ignition key does have to be on in order to operate the work lights, but extended use without the engine operating to charge the battery is not recommended.



FIG 4.67

IV. OPERATING INFORMATION

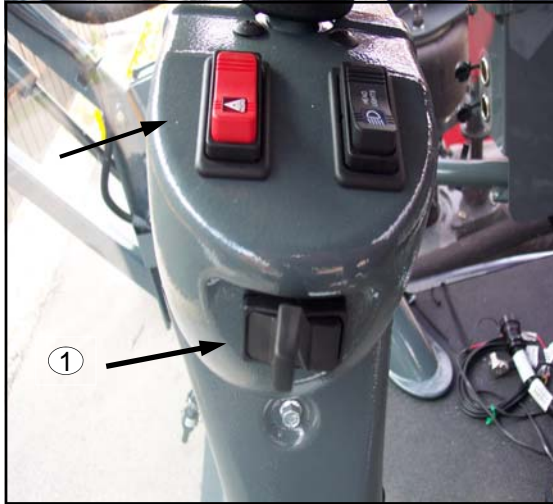

FIG 4.68

Turn Signals

To activate the front (fig. 4.69) and rear turning signals (fig. 4.70, item 1), move the turn signal lever (fig. 4.68, item 1) forward to turn right and back to turn left. Steering column-mounted turn signal indicators will correspondingly flash when either side of the turn signals is activated. The turn signal lever is not a self-centering switch; you must return it to the "OFF" position by hand after completing your turn.



FIG 4.69

Hazard/Warning Lights

To activate the flashing hazard/warning lights (fig. 4.69 & 4.70,) depress the "FLASHER" switch (fig. 4.68) Activate the hazard/warning lights anytime traveling on a public road, day or night, unless prohibited by law. Rotary warning lights are an option, (Fig 4.70A). Flasher switch will activate these lights.

Running Lights

Activating the highway lights (see page 47) will also turn on the "RED" running lights on the rear of the machine (fig. 4.70, item 2).

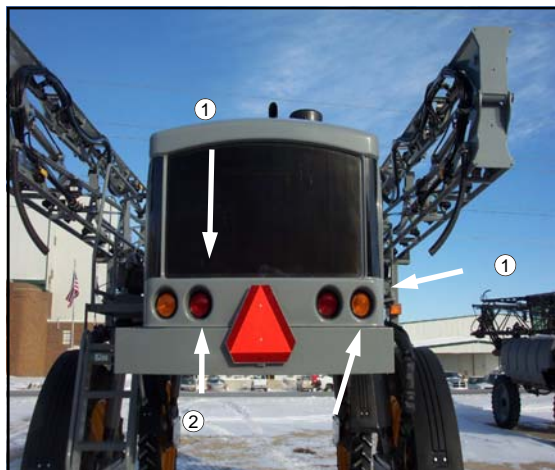

FIG 4.70



FIG 4.70A

IV. OPERATING INFORMATION

HAGIE STS 10 CAB



FIG 4.71

Emergency Exit.....	51
Windshield Wiper/Washer.....	52
Message Center.....	53

IV. OPERATING INFORMATION



FIG 4.72

Emergency Exit

The right cab glass may be broken in the event that an emergency exit is required.

1. Use the exiting tool located right rear of window frame (fig. 4.72) and break window (fig 4.73).
2. Push window outward until there is room to exit.
3. Climb out through and away from hazardous situation.



FIG. 4.73

IV. OPERATING INFORMATION



FIG 4.75

Windshield Wiper/Washer

To turn the windshield wiper on, locate the windshield wiper switch on the right side of the head liner (fig. 4.75, item 1). Depress the switch to the “ON” position. The wiper will continue to operate until the switch is returned to the “OFF” position.

To activate the windshield washer pump, depress the windshield washer switch (fig. 4.75, item 2) and hold the switch down until the desired amount of washing solution has been applied and then release the switch. Turn the wiper switch to the “OFF” position when the washing solution has been completely wiped away.



FIG 4.76

Message Center

The message center in the cab of a Hagie STS 10 offers valuable information as the following (fig 4.76).

1. Tread setting of left rear and right rear tires.
2. Engine RPM
3. Engine oil pressure
4. Hour meter
5. Fuel level
6. Water temperature
7. Odometer
8. Battery voltage

This information can also be viewed by using the up and down arrows.

IV. OPERATING INFORMATION

Air Suspended Seat

1- Seat Cushion Adjustment. Rotate knob to desired cushion position.

2- Height Adjustment. Pull knob out to lower seat. Push knob in to raise seat.

3- Lateral Isolator. Lift lever to engage lateral Iso-lator. Push lever down for lock-out

4- Ride Firmness Adjustment. Rotate knob counterclockwise for firm ride, clockwise for soft ride. For average ride, rotate knob to middle of travel.

5- Fore-Aft Adjustment. Pull lever out and move seat.

6- Fore-Aft Isolater. Lift lever to engage fore-aft isolater. Push lever down for losk-out.

7-Backrest Adjustment. Lift lever to stop and lean rearward or forward to adjust backrest position.

8-Armrest Tilt Adjustment. Turn counterclockwise to lower tilt, clockwise to raise tilt.

9-Lumbar Adjustment. Rotate knob clockwise to increase lumbar support, counterclockwise to decrease support.

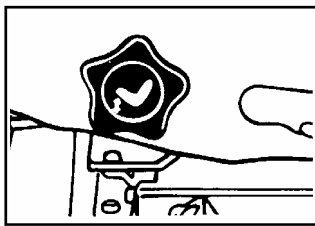

1

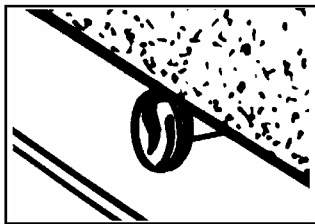

2

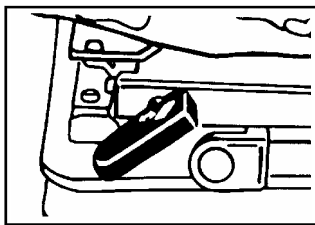

3

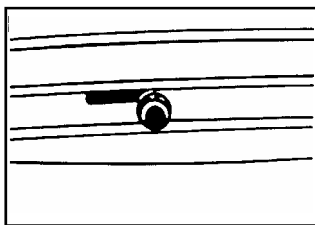

4

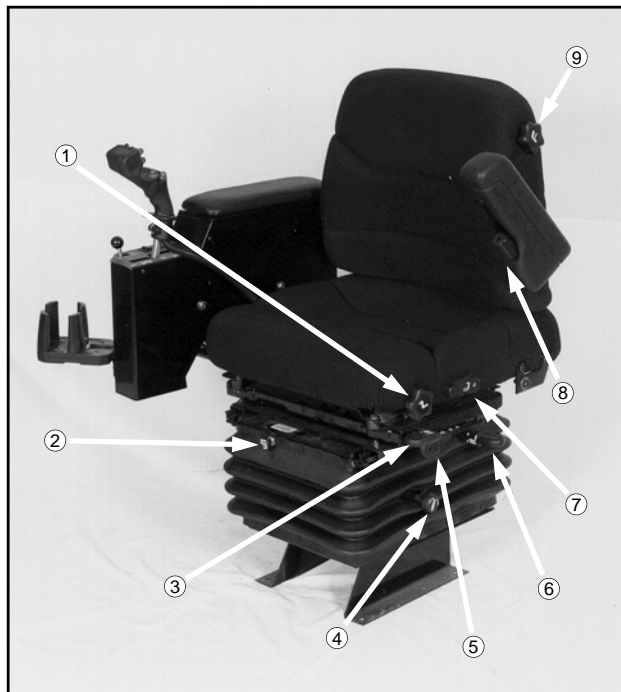
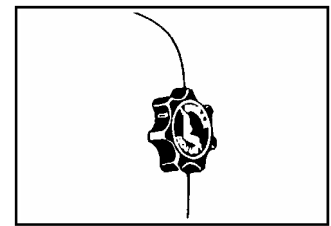
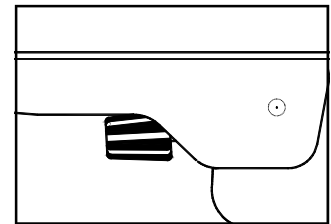

FIG 5.87



9



8

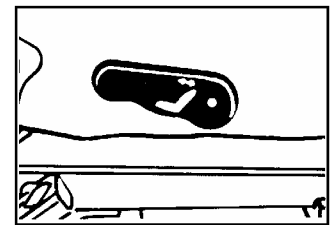

7

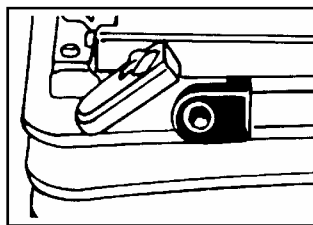

5

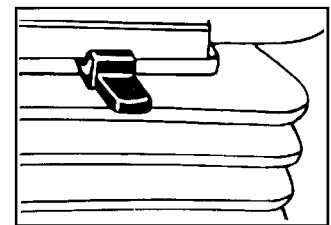

6

V. CALIBRATION

CALIBRATING YOUR SPRAYING SYSTEM

It is important to apply chemicals as recommended by the manufacturers of the product. In order to do so, the spraying system must be properly calibrated. Determine the speed at which the sprayer will be driven while applying chemicals.

To select the best speed, consider the lay of the land, the condition of the soil, the type of crops, the height of the crops, etc. Select the nozzle spacing (distance between each nozzle on the spray boom) best suited for the intended spraying job.

For help in determining the nozzle spacing and height of boom, refer to the Spray Product Catalog that accompanies this manual. There are several types and sizes of nozzles. Select (as recommended by the catalog) and install the type and size of nozzles best suited for the intended spraying job. The type and size of nozzles selected will depend upon the speed the sprayer will travel, the nozzle spacing, and the number of gallons one intends to apply per acre.

IMPORTANT:

**DO NOT ADD CHEMICALS UNTIL
CALIBRATION IS COMPLETED.**

VERIFYING CALIBRATION

Check with manufacturer on recommended spray pressure. To test your system, fill the solution tanks with clean water. Do not add chemicals until calibrated and verified.

With brakes applied, start the engine of the sprayer; throttle the engine to operating speed and remain parked. Turn on all boom section solution

switches. Make sure there are no leaks and that all nozzles are spraying a desirable pattern. Continue spraying in the stationary position for at least 10 minutes for proper warm-up of the sprayer and its system. Catch one nozzle's spray for one minute in an adequately sized and marked container.

V. CALIBRATION

The measured flow rate should be the same as the flow rate shown on the chart below. The chart shows rate of discharge in gallons per minute for various field speeds and row spacings to apply 10 gallons per acre.*

If the measured flow rate is not the same as that on the calibration tube's chart, consult the

trouble shooting guide in the service manual for the spray system's monitor.

All nozzles should be spraying at about the same flow rate. If one drives the sprayer at the proper speed and maintains the right pressure setting while spraying, the desired gallons per acre will be applied.

RATE OF DISCHARGE

Tip Spacing	GALLONS PER MINUTE**				
	4 mph	5 mph	6 mph	7 mph	8 mph
15"	.101	.126	.151	.176	.202
16"	.107	.133	.160	.187	.214
17"	.114	.142	.171	.199	.228
18"	.121	.151	.181	.211	.242
19"	.127	.158	.190	.222	.254
20"	.134	.167	.201	.234	.268
30"	.201	.251	.303	.351	.403
36"	.242	.302	.363	.423	.484
38"	.255	.318	.382	.446	.510
40"	.269	.336	.403	.470	.538

* Divide by 10 to get 1 gallon per acre rate

** At a rate of 10 gallons per acre

VI. TRANSPORTING

A. DRIVING

When driving the sprayer on a public road or highway, drive carefully and follow these steps.

1. Always have the booms in the folded position and cradled when driving or transporting.
2. Flashing hazard/warning lights have been placed on the sprayer to warn other drivers.
3. Know and obey all state laws for driving farm equipment on a public road or highway.
4. Adjust the sprayer's speed to suit the conditions.
5. Slow down and use turn signals before turning.
6. Pull over to the side road before stopping.
7. Keep a proper lookout, and maintain control of the sprayer.
8. Do not drive under trees, bridges, wires or other obstructions unless there is clearance.
9. Use extra care before entering or leaving a public road or highway.
10. A SMV (Slow Moving Vehicle) emblem has been mounted on the sprayer to warn other drivers that one is moving slowly. Keep it properly displayed, unless prohibited by law.

B. TRAILERING:

NOTE:

Extra care should be taken when loading the sprayer onto any trailer. Consider whether it is best to back the sprayer on or drive the sprayer forward.

1. Loading:

WARNING

**Never load or unload a sprayer
with solution in the tanks.**

NOTE:

Be sure to read and understand the trailer's owner and operator manual. Hitch the trailer to the pulling vehicle as shown in the trailer's owner and operator manual.

VI. TRANSPORTING

When moving the sprayer onto a trailer, follow these steps completely:

- a. Pull the trailer to flat ground. Apply the pulling vehicle's parking brake and turn off the engine. Use tire chocks to keep the trailer from moving.
- b. Fold in the sprayer's booms and lower to the boom cradle.
- c. Lower the trailer ramps and set the ramp spacing for the sprayer's tread setting.
- d. Get someone to help guide you onto the trailer. Keep everyone a safe distance from the sprayer.



- e. Allow enough room between the sprayer and the pulling vehicle for turning.
- f. Secure the sprayer to the trailer. See the trailer's owner and operator manual for instructions.
- g. Cover or remove the SMV (Slow Moving Vehicle) emblem when traveling over 25 miles per hour.

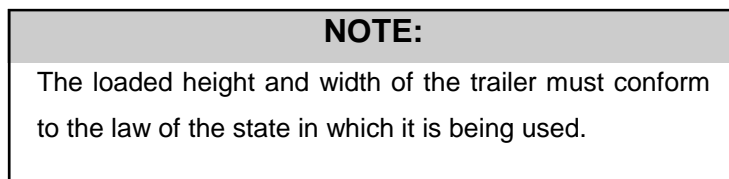

2. Unloading:

When moving the sprayer off of a trailer, follow these steps completely:

- a. Pull the trailer to flat ground. Apply the pulling vehicle's parking brake and turn off the engine. Use tire chocks to keep the trailer from moving.
- b. Lower the trailer ramps and set ramp spacing for the sprayer's tread setting.
- c. Release securing restraints carefully.
- d. Get someone to help guide off the trailer. Keep everyone a safe distance from the sprayer.
- e. Uncover or replace the SMV (Slow Moving Vehicle) emblem.

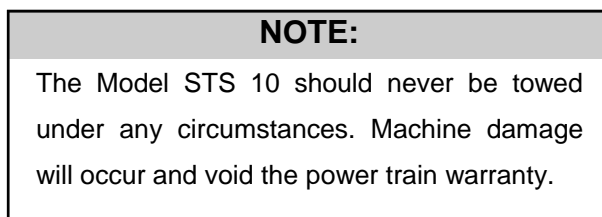

VII. SERVICE AND MAINTENANCE

PAGE NO	Service Point	C L E A N	C H A N G E	C H E C K	G R E A S E	D R A I N
62	ENGINE OIL		A	DAILY		
64	RADIATOR COOLANT LEVEL			DAILY		
64	COOLANT CONCENTRATION		AS REQ	500 HRS*		
68	RADIATOR GRILLE SCREEN	DAILY				
74	ENGINE DRIVE BELT		AS REQ	DAILY		
74	A/C COMPRESSOR BELT		AS REQ	250 HRS		
66	A/C COMPRESSOR		B			
70	FUEL FILTER (WATER SEPARATOR)		500 HRS*			DAILY
70	IN-LINE FUEL STRAINER		AS REQ			
67	AIR INTAKE FILTER	NOT REC	C			
67	FILTER MINDER®		D	DAILY		
62	HYDRAULIC RESERVOIR OIL LEVEL		500HRS**	DAILY		
68	HYDRAULIC CHARGE and SUCTION FILTER (1 in tank)		E			
69	HIGH-PRESSURE IN-LINE FILTER (TREAD ADJUST VLVS)	AS REQ				
69	SOLUTION LINE STRAINER	AS REQ		DAILY		
63	TORQUE HUB® OIL LEVEL		F	DAILY		
79	WET TANK					DAILY
71	FRONT LEG STRG ZERKS (4 PLACES – 2 EACH)				50 HRS	
71	REAR LEG BRG ZERKS (2 PLACES – 1 EACH)				500 HRS*	
76	TREAD ADJUSTMENT BEARING TORQUE		AS REQ	50 HRS		
72	BATTERIES	100 HRS	AS REQ	DAILY		
75	LUG NUT TORQUE			G		
80	TIRE PRESSURE			50 HRS		
70	FRESH AIR CAB FILTER	50 HRS	AS REQ			
70	CHARCOAL CAB FILTER		AS REQ			
70	RECIRCULATION FILTER		AS REQ			
79	SPRAY NOZZLE DIAPHRAGMS & SPRAY TIPS			500HRS**		

*OR YEARLY, WHICHEVER COMES FIRST; OR AS REQUIRED

**OR AT THE BEGINNING OF THE SEASON, WHICHEVER COMES FIRST; OR AS REQUIRED

NOTE A: SEE ENGINE MANUFACTURER'S HAND BOOK

NOTE B: CHARGE AS REQ; USE PROPER EQUIPMENT

NOTE C: FOLLOW FILTER MINDER READINGS

NOTE D: RESET EACH TIME YOU SERVICE AIR FILTER

NOTE E: 1ST 50 HRS, THEN 250 HRS THEREAFTER

NOTE F: 1ST 50 HRS, THEN 250 HRS THEN YEARLY

NOTE G: IMMEDIATELY, THEN 50 HRS THEREAFTER

VII. SERVICE AND MAINTENANCE

SERVICE INTERVALS

Initial checks after receiving machine

IMMEDIATELY  then 

- 1) Check lug nut torque, then every 50 hours (page 75)

FIRST 50 HOURS  then  or 

- 1) Change Torque Hub[®] oil, then every 500 hours (page 63)
- 2) Change hydrostatic charge pressure and suction filter, then every 250 hours (page 68)

Daily 

- 1) Check engine oil (page 62)
- 2) Drain fuel filter (water separator) (page 70)
- 3) Check radiator coolant level (page 65)
- 4) Check radiator coolant (page 64)
- 5) Check engine drive belt (page 74)
- 6) Check Filter Minder[®] (page 67)
- 7) Check hydraulic oil reservoir level (page 62)
- 8) Check solution line strainer (page 69)
- 9) Drain wet tank (page 79)
- 10) Check batteries (page 72)

VII. SERVICE AND MAINTENANCE

As Required



- 1) Change coolant concentration (page 64)
- 2) Clean radiator grille screen (page 68)
- 3) Change engine drive belt (page 74)
- 4) Change A/C compressor belt (page 74)
- 5) Charge A/C compressor (page 66)
- 6) Change fuel filter (water separator) (page 70)
- 7) Change in-line fuel pre-filter (page 70)
- 8) Change hydraulic reservoir oil (page 62)
- 9) Clean high-pressure in-line filter on tread adjust stack valve (page 69)
- 10) Clean solution line strainer (page 69)
- 11) Change batteries (page 72)
- 12) Knock particles from fresh air intake cab filter (page 70)
- 13) Change fresh air intake cab filter (page 70)
- 14) Change charcoal cab filter (page 70)
- 15) Knock particles from recirculating cab filter (page 70)
- 16) Change recirculating cab filter (page 70)
- 17) Check and replace spray nozzle diaphragms and spray tip (page 79)
- 18) Change tread adjust bearing bolt torque (page 76)

VII. SERVICE AND MAINTENANCE

Every 50 HOURS



- 1) Check tire pressure (page 80)
- 2) Check lug nut torque (page 75)
- 3) Visually inspect tread adjust bearing bolts (page 76)
- 4) Grease front steering zerks (page 71)
- 5) Knock particles from fresh air intake cab filter (page 70)

Every 100 HOURS



- 1) Check Torque Hub[®] oil level (page 63)
- 2) Clean batteries (page 72)
- 3) Check tread adjust bearing bolt torque (page 76)

Every 250 HOURS



- 1) Check A/C compressor belt (page 74)
- 2) Change hydrostatic charge pressure and suction filter (page 68)

Every 500 HOURS



or



- 1) Check coolant concentration (page 64)
- 2) Change fuel filter (water separator) (page 70)
- 3) Change hydraulic reservoir oil (page 62)
- 4) Change Torque Hub[®] oil (page 63)
- 5) Check spray nozzle diaphragms and spray tips (page 79)
- 6) Grease rear leg bearing zerks (page 71)

VII. SERVICE AND MAINTENANCE



FIG 7.01

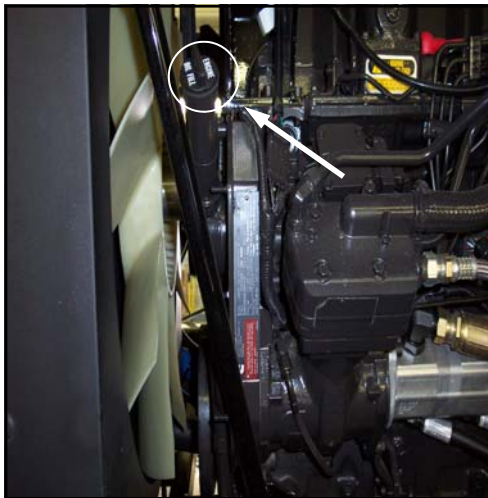

FIG 7.02

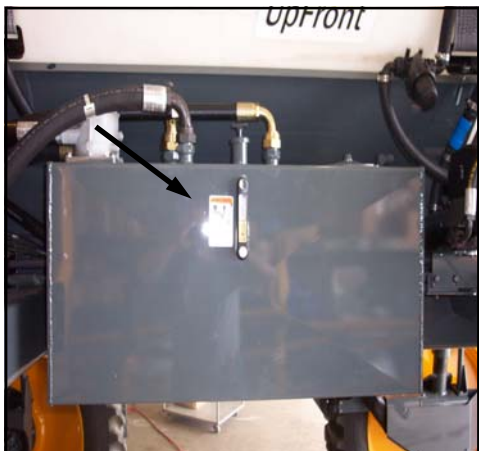

FIG 7.03

FLUIDS

Engine oil

OIL LEVEL - The engine oil level dipstick is located on the left-hand side of the engine (fig. 7.01). Never operate the engine with the oil level below the “L” (low) mark or above the “H” (high) mark. Wait at least five minutes after shutting off the engine to check the oil level; this allows time for the oil to drain to the oil pan. Check the engine oil level daily.

CAPACITY - Low to high mark capacity is 2.0 quarts. Engine oil pan capacity is 17 quarts. Refer to Engine Operation and Maintenance manual for maintenance schedule.

NOTE:

The engine must be level when checking the oil level to make sure the measurement is correct.

Hydraulic Oil Reservoir

OIL LEVEL - Check the sight gauge level on the hydraulic oil reservoir (fig 7.03) daily. Add just enough fluid so the level is in the center of the sight gauge. Always check the hydraulic oil level when it is cool. Hydraulic oil will expand when heated.

TYPE - Premium hydraulic fluids containing high quality rust/oxidation/and foam inhibitors are required. Hydraulic oil must conform to one of the following types: anti-wear hydraulic oil, type F automatic transmission fluid, or agricultural hydraulic transmission fluid. Replace the oil in the hydraulic reservoir at 500 hours or at the beginning of each spraying season, whichever comes first.

VII. SERVICE AND MAINTENANCE

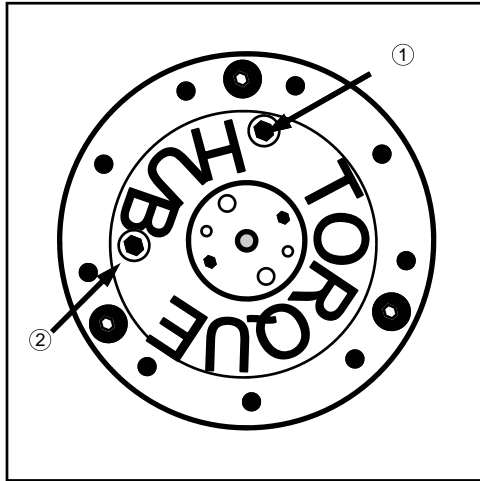

FIG 7.04

Torque Hub[®] Oil

OIL LEVEL - Each Torque Hub[®] should maintain an oil level of half full at all times. Less than that would limit lubrication, and over half full could cause overheating and damage. To check oil level, position Torque Hub[®] so one of the face plugs is positioned at 12 O'clock (fig. 7.04, item 1). The other plug will be either at 9 O'clock or 3 O'clock (fig. 7.04, item 2). Remove the lower plug: if no oil comes out, oil level is too low. Check Torque Hub[®] oil level every 100 hours.

If EP-90 oil is needed, remove the top plug also and fill just until it starts to come out the lower hole. With the oil at a satisfactory level, re-install plugs.

CHANGE - The Torque Hub[®] oil should be changed after the first 50 hours of operation, preferably in a loaded condition. Subsequently, it should be changed every 500 hours after that, or once a year whichever comes first.

To change the Torque Hub[®] oil, position one of the plugs at 6 O'clock, and the other at either 3 O'clock or 9 O'clock. Remove the bottom plug to drain the oil. Once all of the oil is drained, re-install the bottom plug and remove the top plug. Refill Torque Hub[®] with EP-90 oil as described above.

GENERAL MAINTENANCE - If your sprayer is going to sit for an extended period of time, occasionally rotate the hubs by driving the sprayer forward or backward a few feet to adequately coat all internal hub parts. This will prevent rusting if moisture inadvertently entered the hub during an oil change. Failure to rotate hub and disperse oil may cause rusting and internal damage.

VII. SERVICE AND MAINTENANCE



FIG 7.05

Cooling System

COOLANT TYPE - Your cooling system should always be sufficiently charged with an adequate mixture of antifreeze and water, regardless of the climate, in order to maintain a broad operating temperature range. Your cooling system has been factory-charged with an ethylene glycol-based antifreeze.

NOTE:

Ethylene glycol-based antifreeze and propylene glycol-based antifreeze should never be mixed.



FIG 7.06

CHECKING CONCENTRATION - The radiator cap is located toward the rear of the engine compartment (fig. 7.05). Never remove a cap from a hot engine. Always allow the engine to cool before servicing cooling system.

A 50/50 antifreeze/water mixture is a conservative mixture which allows good protection against both overheating and freezing. If a stronger antifreeze mixture is required, be sure not to exceed the engine manufacturer's guidelines for antifreeze mixing. The table in figure 7.07 gives a few examples of ethylene glycol antifreeze/water mixture protection values. Consult the engine manufacturer's handbook for further information.

Ethylene Glycol		
40%	-23°C	-10°F
50%	-23°C	-34°F
60%	-23°C	-65°F

FIG 7.07

Concentration should be checked every 500 hours or at the beginning of each winter, whichever comes first. It should be checked using a refractometer; "floating ball"-type density testers or hydrometers are not accurate enough for use with heavy duty diesel cooling systems.

VII. SERVICE AND MAINTENANCE



FIG 7.08



FIG 7.09

CHANGING COOLANT - Your coolant should periodically be changed to eliminate the buildup of harmful chemicals. Drain and replace the coolant every other spraying season or every 1,000 hours of operation, whichever comes first. Refill only with ethylene glycol coolant. Antifreeze should be mixed only with soft water because hard water contains minerals which break down the anti-corrosion properties of antifreeze.(FIG 7.08).

Fuel

TYPE - No. 2 diesel fuel is recommended for the best economy and performance under most operating conditions. In operating conditions under 32° F, use a blend of No. 1 and No. 2 diesel fuel. The addition of No. 1 diesel fuel may cause loss of power and/or fuel economy.

STORING - See section 8 on sprayer storage.

REFILLING - Always turn off the engine and allow it to cool before refueling. Never smoke while fueling. Keep a fire extinguisher within reach while refueling.

The fuel cell on an STS 10 holds 150 gallons - do not fill it completely: fuel can expand and run over. Wipe up all spilled fuel and clean with detergent and water before starting the engine.

VII. SERVICE AND MAINTENANCE



FIG 7.09

Air Conditioning

TYPE - The cab on your sprayer is equipped with a R-134a air conditioning system.

RECHARGING - Recharge it only with R-134a refrigerant. If your air conditioning system is mistakenly charged with R-12 refrigerant, serious problems, such as compressor seizure, may result. Therefore, confirm refrigerant before recharging system.

If you do not have the proper recharging equipment, it is recommended that you allow an independent service agent service your air conditioning system.



FIG 7.10

Windshield Washer Fluid

The windshield washer reservoir is located rear of the cab (fig. 7.10). Check it occasionally and refill it from the cap inside the cab with non-freezing automotive windshield cleaner as required.

FLUID CAPACITIES AND TYPES

Engine oil pan, including filter	17 quarts SAE 15W-40
Engine oil dipstick, L-H mark	2 quarts
Hydraulic oil reservoir	32 gallons anti-wear hydraulic oil
Hydraulic system (reservoir, lines, filter, cooler, etc).....	55 gallons
Torque Hub [®] oil level	
Front (2).....	approx. 84 oz. ea. EP-90
Rear (2)	approx. 62 oz. ea. EP-90
Engine cooling system.....	18 gallons ethylene glycol
Fuel cell.....	150 gallons No. 1 or 2 diesel

VII. SERVICE AND MAINTENANCE

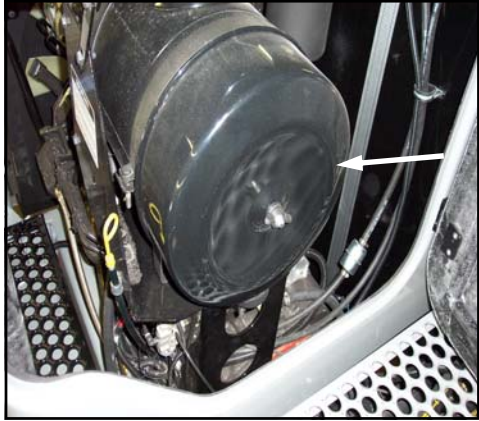

FIG 7.12



FIG 7.13



FIG 7.14

NOTE:
Service the air cleaner before the yellow indicator reaches the red line of the Filter Minder®.

FILTERS

Engine Air Intake

LOCATION – The engine air intake filter is accessed by opening the door on the front of the engine compartment (fig. 7.12).

REMOVAL - The engine air intake filter element should only be removed if it is going to be replaced. After loosening the air cleaner clamp and removing the end cap, carefully remove the filter so as to not knock any dust off the filter and into the air intake passage (fig. 7.13). Secondary filter doesn't need to be replaced if primary is intact.

REPLACEMENT - Your sprayer is equipped with a Filter Minder® to notify you of filter element efficiency. Follow its guidelines for servicing. (See below.) At appropriate service time, install the new element carefully to ensure proper sealing.

CLEANING - It is not recommended to clean the air filter element. However, a clean damp cloth should be used to wipe dust and foreign material from the air cleaner housing. iinstalled.

NOTE:
Do not tap filter to remove dust. Engine damage may occur due to crushed filter caused by tapping. If Filter Minder® indicates restriction, remove old filter, discard and install new filter only.

Filter Minder®

LOCATION - The Filter Minder® is an air restriction monitoring system that progressively and constantly indicates how much air filter capacity remains. It is mounted on foamer bracket . (fig. 7.14). Check its reading daily.

SERVICE - Service the air cleaner when the Filter Minder® reads 20" (80% of average dirt holding capacity).

VII. SERVICE AND MAINTENANCE



FIG 7.15

Radiator Screen

In order to maintain maximum air flow through the engine cooling system's radiator, oil cooler, and air conditioning condenser, the cooling air intake grille (fig. 7.15) must be inspected often and periodically cleaned.

NOTE:

Failure to keep cooling systems clean can cause over heating and damage to the hydrostatic system and/or engine.

Compressed air will dislodge most large trash or loose dirt after the hood has been opened for service. Blow out the screen away from the machine. Water from a pressurized hose may also be used, or if necessary the screen may be soaked with soapy water and scrubbed with a brush.

NOTE:

When cleaning cooling fins of the radiator, oil cooler, or A/C condenser with compressed air or water, be careful not to damage cooling fins which may impair cooling capabilities.



FIG 7.16

Hydraulic Filter

Remove and install a new 10 Micron rated suction filter (fig. 7.16) at the end of the first 50 hours of use; subsequently, replace the filter every 250 hours, or once a year, whichever comes first.

VII. SERVICE AND MAINTENANCE

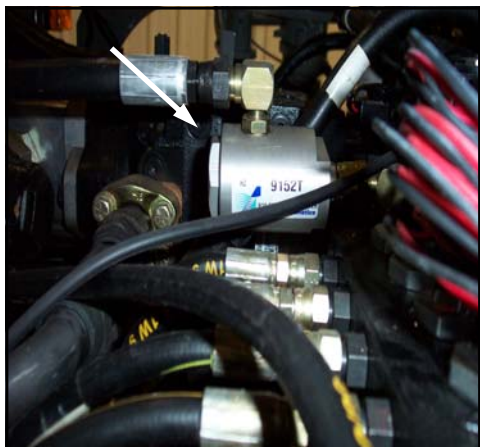

FIG 7.17

High Pressure In-line Filter

The valves on the tread adjust circuit are protected by a 90 Micron in-line sintered bronze filter (fig. 7.17). When the filter element is removed for cleaning, caution should be taken so the gasket is in the proper place when re-installing (fig. 7.18). Also, re-install filter paying attention to direction of flow so the end marked "OUT" is oriented correctly.



FIG 7.18

Solution Line Strainer

To help maintain consistent application rates, check the solution line strainer (fig. 7.19) daily for blockage. Clean the strainer screen as required. Be sure to wear the appropriate clothing while removing and cleaning the line strainer screen. Confirm the gasket is in place before re-installing the screen.



FIG 7.19

VII. SERVICE AND MAINTENANCE

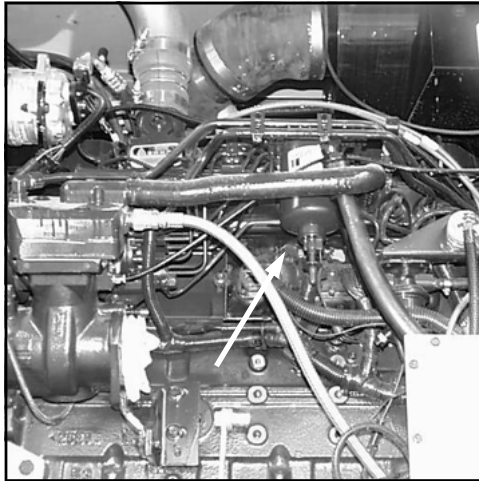

FIG 7.20

Fuel Filter

PRIMARY (WATER SEPARATOR) - (fig. 7.20) Drain water and sediment from the separator daily. Replace every 500 hours or once a year, whichever comes first.

IN-LINE STRAINER - (fig. 7.21) Note direction of fuel flow arrow when replacing.

Fresh Air Cab Filters



FIG 7.21

PAPER FILTER and Recirculating Filter - (fig. 7.22 item 1) .The paper filter should be cleaned every 50 hours, or more often if necessary. Remove the paper element and gently tap it against a flat surface. Direct low pressure compressed air through the filter to remove larger particles. Replace the paper filter if necessary.

CHARCOAL FILTER - (fig. 7.22 item 2) Remove and replace at the first sign of chemical odor entering the cab.

Figure 7.23 shows air tube that fresh air comes into the cab.

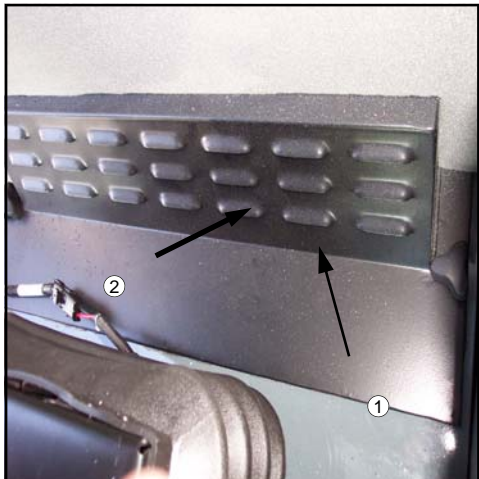

FIG 7.22



FIG 7.23

VII. SERVICE AND MAINTENANCE

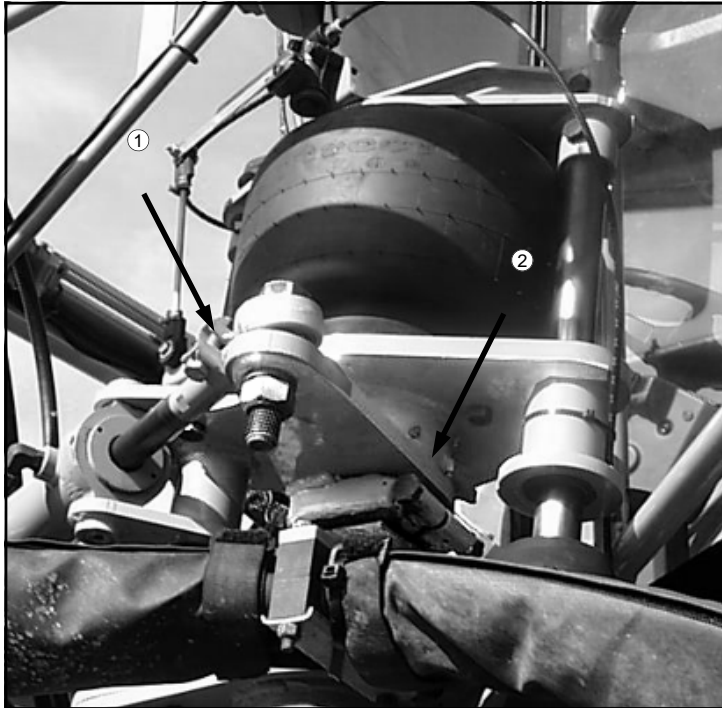

FIG 7.24

LUBRICATION Steering Bearings

Grease zerks are located on the “tie rod” ball pivot (fig. 7.24, item 1) and steering plate (fig. 7.24, item 2) of each front leg (four places total). Grease all four zerks once a week or every 50 hours, whichever comes first. To maintain bearing integrity, grease the bearing plate on each rear leg every 500 hours or once a year, whichever comes first.

Grease front and rear leg towers (fig. 7.25 item 1 and 2), daily. DO NOT USE AIR TYPE GREASE GUN TO LUBE LEG TOWERS< MAY RESULT IN SEAL DISTORTION.

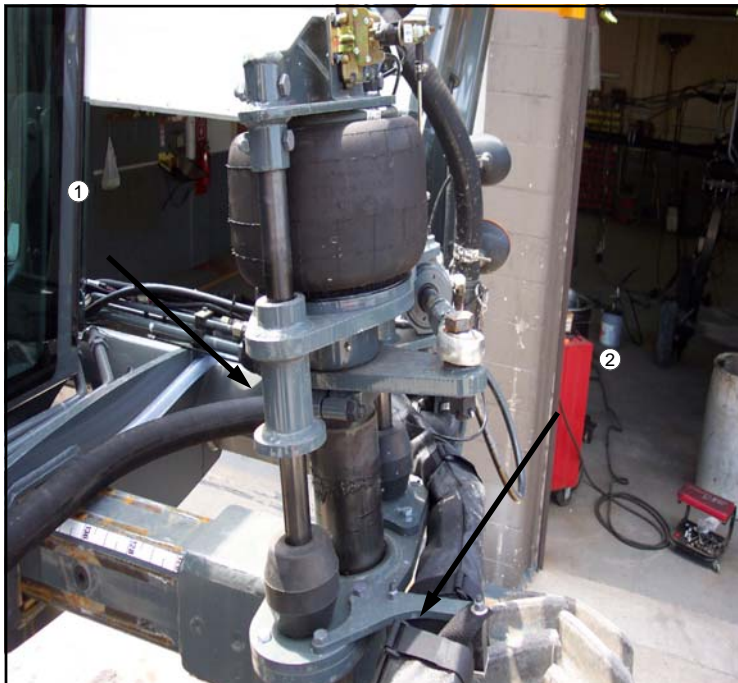

FIG 7.25

VII. SERVICE AND MAINTENANCE

ELECTRICAL

Batteries

SAFETY

CAUTION

Batteries contain sulfuric acid. Avoid contact with skin, eyes, or clothing. Do not inhale fumes or ingest liquid. Batteries contain gases which can explode. Keep sparks and flame away while servicing.

SERVICE ACCESS - The batteries are located at the rear of

the machine behind battery service access panel (fig. 7.26).



FIG 7.26

NOTE:

When servicing the electrical system always disconnect the batteries. Remove the ground cable first and connect it last.

NOTE:

To ensure the best electrical contact, battery terminal connections should be as clean and as tight as possible.



FIG 7.27

Install replacement batteries with ratings equivalent to or higher than the specs below.

VOLTAGE 12 V (only)

CCA (30 sec. at 0° F)..... 950

RESERVE CAPACITY 185 min.
at 25 amps

CLEANING - Disconnect battery cables from batteries.

Remove all corrosion with a wire brush or battery post brush. Wash the cable connections and battery posts with a weak solution of baking soda or ammonia. Apply petroleum jelly or grease to prevent future corrosion. Reconnect the cables to the batteries making sure they are tight. Clean every 100 hours.

CHARGING - To ease charging of the batteries, there is a

set of auxiliary battery charging posts on the rear of the sprayer's mainframe (fig. 7.27). Connect your charging cables to them just as you would to the battery, positive cable to positive terminal, and negative cable to negative terminal. Keep these terminals clean and their caps in place when not in use.

VII. SERVICE AND MAINTENANCE



FIG 7.28

Circuit Breakers

The Hagie STS 10 has circuit breaker and fuse systems located in various locations. Under right hand console, (fig. 7.28) for the cab functions, under the cab, (fig 7.31) for the light functions and engine compartment, (fig. 7.30) for the engine functions. (Figure 7.29A shows the decal for the cab fuses, circuit breakers and relays) . Figure 7.29B shows power ports for add on radios.

Refer to the Hagie STS 10 Parts Manual for specific information regarding correct breaker location and size.

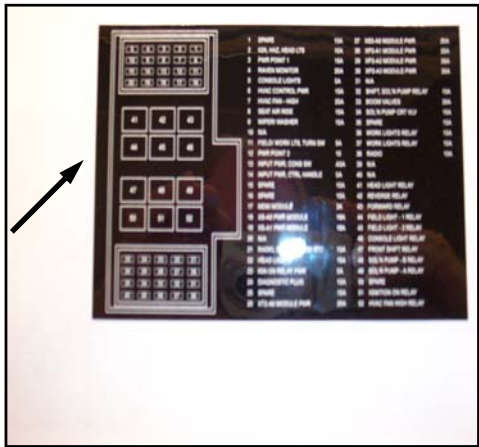

FIG 7.29A

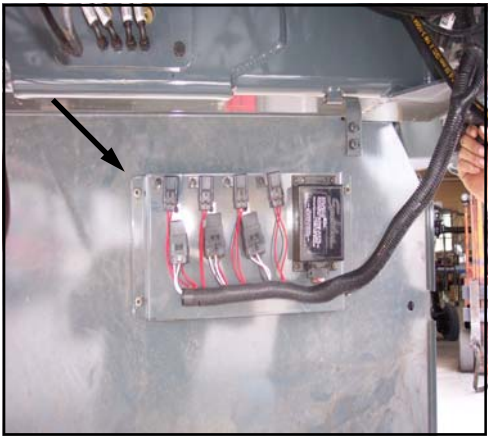

FIG 7.31



FIG 7.29B



FIG 7.30

VII. SERVICE AND MAINTENANCE

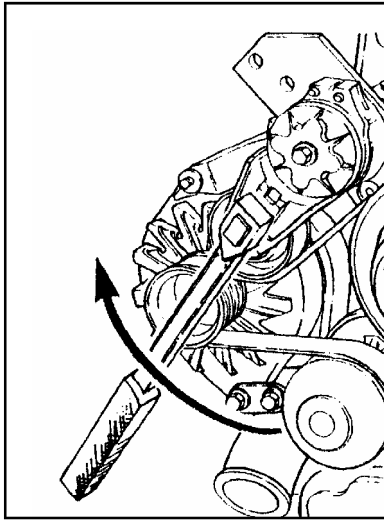

FIG 7.31

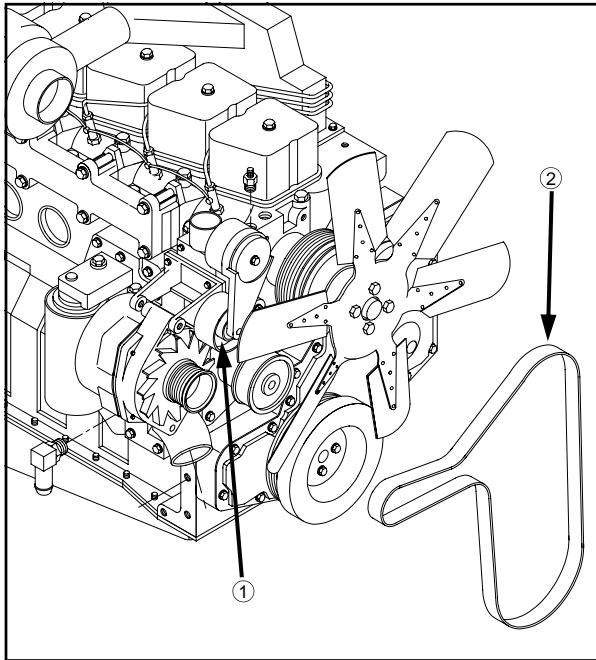

FIG 7.32

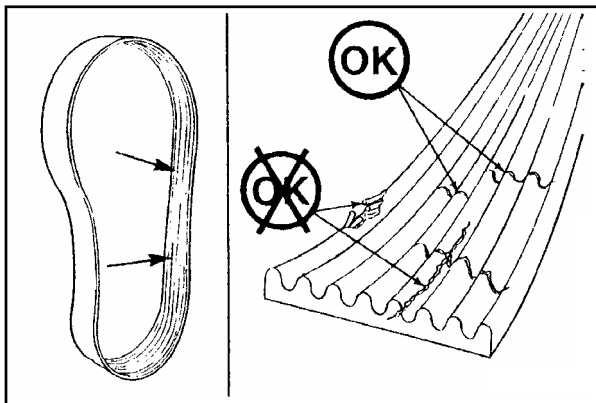

FIG 7.33

BELTS

Engine Drive Belt

REMOVAL - Insert a 3/8 inch square ratchet drive (fig. 7.31) into the belt tensioner (fig. 7.32, item 1) and lift upward to remove the belt (fig. 7.32, item 2).

INSPECTION - Visually inspect the belt daily. Check the belt for intersecting cracks (fig. 7.33). Transverse (across the belt width) cracks are acceptable. Longitudinal (direction of belt length) cracks that intersect with transverse cracks are not acceptable. Replace the belt if it is frayed or has pieces of material missing.

A/C Compressor Belt

To tighten air conditioner compressor belt, loosen the two pivot bolts (fig. 7.34, item 1) and the two slide bolts (fig. 7.34, item 2). Using a suitable prying tool, adjust tension on belt to desired tautness. While maintaining tension, re-tighten all four bolts. Inspect belt ever 250 hours.

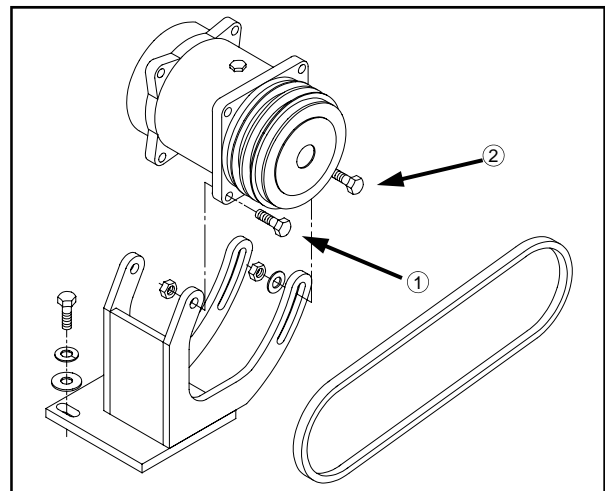

FIG 7.34

VII. SERVICE AND MAINTENANCE

BOLT TORQUE

Wheel Bolts



FIG 7.35

Keep wheel bolts tight.
See owner's manual for
torque specifications.

To install wheel and tire assembly on the Torque Hub[®], lubricate studs with anti-seize grease. Align the wheel bolt holes with the Torque Hub[®] studs and mount the wheel on the hub.

NOTE:

To achieve even torquing consistency, the tire should be completely off the ground.

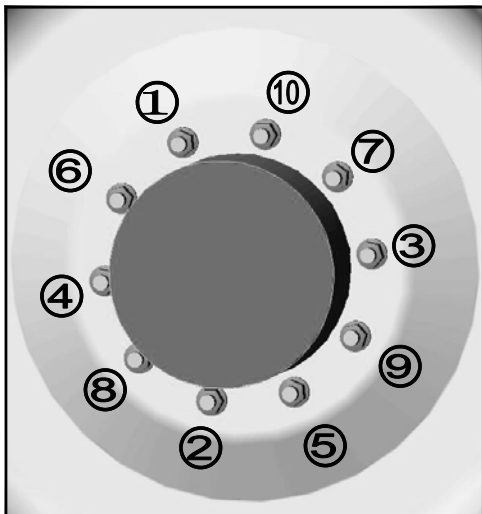

FIG 7.36

Start all of the lug nuts on and tighten them until they are just snug. Following the torque sequence in (fig. 7.36), first turn each lug nut to a torque value of 120 dry foot-pounds. Use slow, even pressure on the torque-wrench. Quick or jerky movements cause inaccurate values. Repeat the same sequence to 150 dry foot-pounds and again finally to 180 dry foot-pounds.

CAUTION

Check lug nut torque immediately after receiving machine and every 50 hours thereafter.

If the wheel turns during lug nut torquing, lower the machine to the ground just enough for the tire to touch and prevent rotation or more preferably, place a suitable wedge between the tire and the ground.

Lower the machine and resume operation. Recheck torque after 30 minutes of operation.

VII. SERVICE AND MAINTENANCE

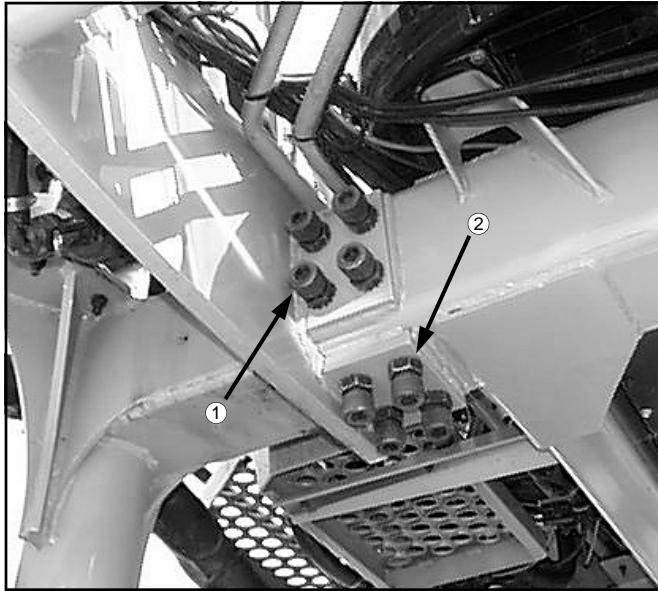

FIG 7.37

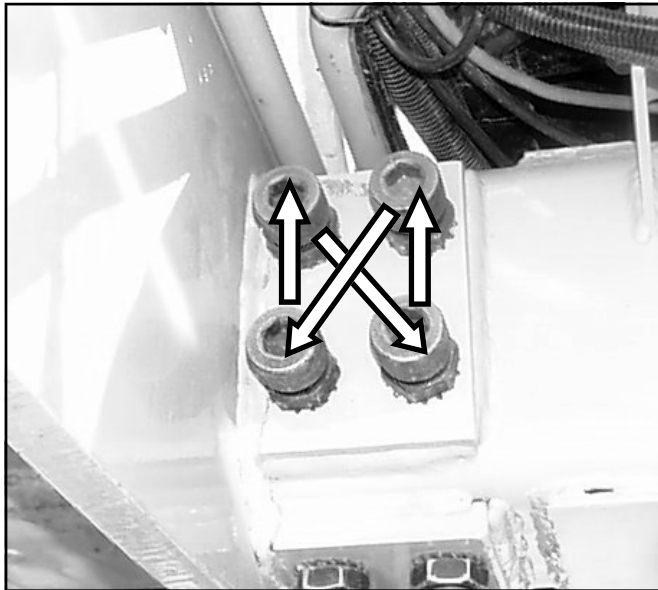

FIG 7.38

NOTE:

If hydraulic tread adjustment will never be operated on your machine, set all bearing bolt torque settings to 50 foot-pounds and continue inspection as above without adjustment test.

Bearing Torque on Hydraulic Tread Adjust Equipped Units

With the engine turned off, visually inspect the tread bearing bolts on both the bottom and side (fig. 7.37) every 50 hours. Torque check them every 100 hours.

To torque check the bearing bolts:

1. Loosen the jam nut (fig. 7.37, item 2) on each bearing bolt.
2. Using a criss-cross or "X" pattern (fig. 7.38), verify current torque on each bolt (fig. 7.37, item 1) is equivalent to last check from 100 hours previous (repeat torque pattern a second time).
3. Then increase the torque two foot-pounds on each bolt using the "X" pattern and retighten each jam nut.
4. Start the sprayer and test the hydraulic tread adjustment (see page 26). If the tread still adjusts smoothly see next step. If the tread does not move skip to step 6.
5. Repeat steps 1 and 3 until the tread does not move.
6. Reduce torque setting to last value that allowed the tread to operate freely, retighten jam nuts and resume operation.

NOTE:

Never operate the unit with the tread bearing bolt torque set below 25 foot-pounds. If the bolt torque has to be loosened to 25 foot-pounds in order for the hydraulic tread adjust to work freely, call Hagie Customer Support.

VII. SERVICE AND MAINTENANCE

TOE-IN

To correctly gauge toe-in, use a tape measure placed at one-half tire height on the front center seam of the front tire compared to the same measurement of the rear of the front tire (subtract the front measurement from the rear measurement - it must be a positive number). Correct toe-in should fall somewhere between one half and three quarters of an inch.

Toe-in is pre-set at the factory and should not have to be adjusted unless the steering cylinders are removed.

Difficulty steering one way versus the other may also indicate incorrect toe-in and may require adjustment. For further assistance regarding toe-in measurement and adjustment, contact the Hagie Customer Support Department.

NOTE:

See page 78 for instructions on adjusting toe-in. See also page 26 for information on recalibrating self-centering cylinders.

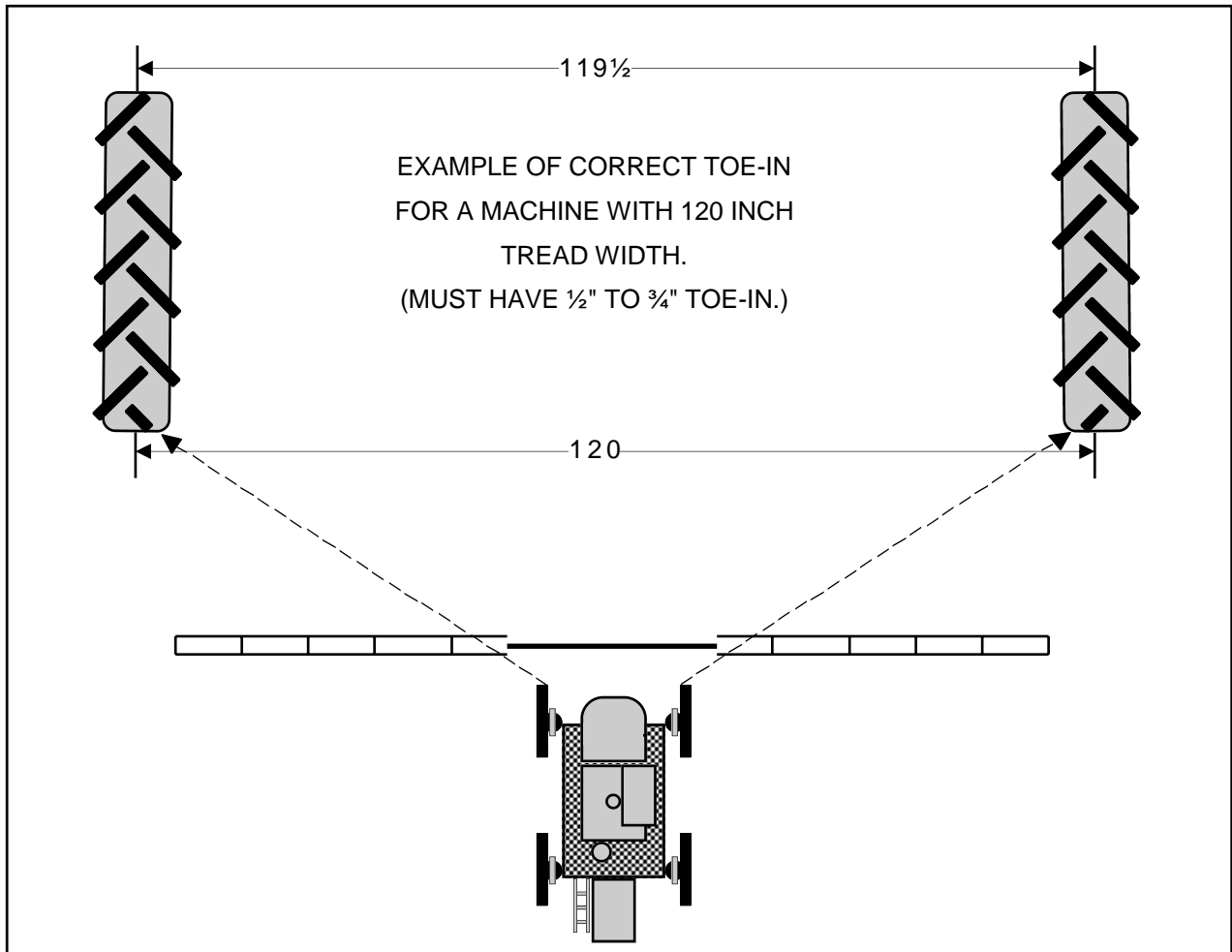

FIG 7.39

VII. SERVICE AND MAINTENANCE

TOE-IN ADJUSTMENT



FIG 7.40



FIG 7.41

To adjust the toe-in of the front tires follow these instructions for both front steering cylinders carefully:

1. Loosen jam nut (fig. 7.41, item 3).
2. Move left and right tires evenly until difference in dimension "A" and "B" (fig. 7.42) are within specified range.
3. Screw swivel assembly in or out on steering cylinder until the swivel joint lines up with steering plate.

NOTE:

Dimension "A" should be $\frac{1}{2}$ " to $\frac{3}{4}$ " less than dimension "B." For more information regarding toe-in, see page 77.

4. Insert bolt through swivel joint and steering plate, and tighten jam nut.

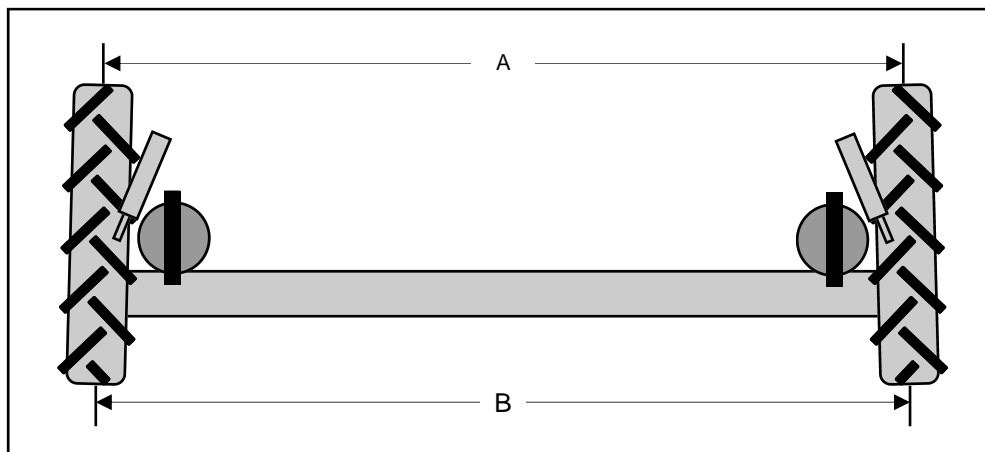

FIG 7.42

VII. SERVICE AND MAINTENANCE

SPRAY SYSTEM

Spray Tips

At the beginning of each season, or as required, remove a random sample of spray tip caps (fig. 7.43, item 3) and inspect the nozzle tips. If they are plugged or worn, clean or replace them.

Nozzle Diaphragms

At the beginning of each spray season, remove each nozzle body cap (fig. 7.43, item 1) and inspect the diaphragm for wear or fit (fig. 7.43, item 2). Replace if necessary. Refer to accompanying manual containing nozzle information.

Calibration

See pages 54-55 on spray system calibration.

Winter Storage

See page 83 on cold weather storage of spray system.

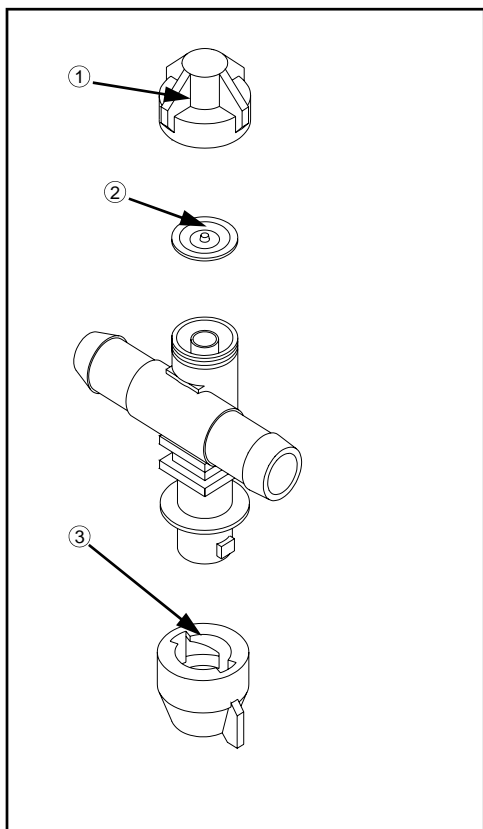

FIG 7.43

FOAM MARKER SYSTEM

Wet Tank

To prevent system condensation from contaminating the engine air compressor, remove moisture from the wet tank daily by pulling on its drain cord (fig. 7.44).

Winter Storage

See page 83 on storage of foamer system.



FIG 7.44

VII. SERVICE AND MAINTENANCE

TIRES



FIG 7.45

Air Pressure

Check tire pressure once a week or every 50 hours of operation (fig. 7.45). Never inflate a tire more than the recommended maximum air pressure. Use an air line with a locking air chuck and stand behind tire tread while filling (fig. 7.46).

NOTE:

Tire pressure will depend on load quantity and type in solution tanks. Refer to page 19 for tire specifications.



FIG 7.46

WARNING

When inflating tire use extension hose with in-line air gauge and clip-on air chuck, which allow operator to stand clear of tire side wall explosion trajectory.

Wheel Bolts

See page 75 for recommended wheel bolt torque specifications and torquing pattern.

Mounting

If you do not have proper mounting equipment, let your local qualified tire sales/service dealer mount the tire for you. Tire should be mounted on rim according to (fig. 7.47), for best traction and tread cleaning action.

Toe-In

See pages 77-78 for information regarding toe-in measurement and adjustment.

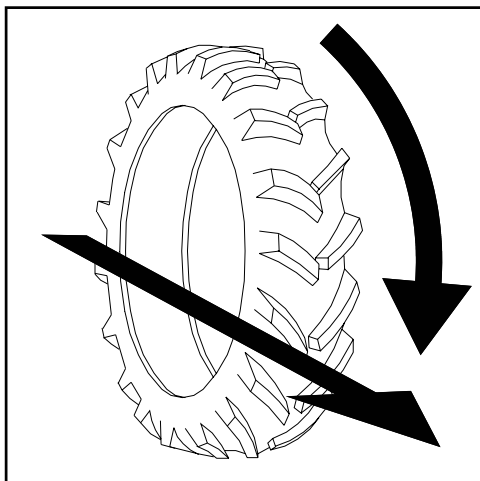

FIG 7.47

VII. SERVICE AND MAINTENANCE

DAILY INSPECTION

Inspection Point	Action (if necessary)
Check	
Engine oil level.....	Add oil
Radiator coolant level.....	Add antifreeze solution
Engine drive belt	Replace belt
Filter Minder®	Replace air filter element
Hydraulic reservoir oil level	Add hydraulic oil
Solution line strainer.....	Remove and clean
Batteries	Clean and/or tighten
Radiator grille screen	Clean
Look for loose or missing items such as shields.....	Tighten or replace
Look for any fluid leaks pooled on machine or ground	Determine cause and correct
Drain	
Fuel/water separator	See page 70
Wet tank.....	See page 79

VIII. STORAGE

A. Preparing the sprayer for storage.

1. Perform daily level checks, lubrication, and bolt and linkage inspections as required in this manual in section eight on maintenance.
2. Every other season, drain the coolant from the engine and radiator. Probe the drain holes during draining to ensure they are not clogged by sludge, scale, or other deposits. Fill the cooling system to the top with a 50/50 water/antifreeze mixture. Run engine to operating temperature and re-check level.

NOTE:

If antifreeze is added, make sure the engine is then run to operating temperature to assure proper mixing of solution.

3. Add a fuel stabilizer to the fuel and fill fuel tank.
4. Run the engine until it is at operating temperature, then drain the engine oil. Refill with fresh oil of recommended weight and install a new lubricating oil filter element.
5. With the engine at normal operating temperature, cycle all hydraulic functions including the steering.
6. Release tension on all belts. For more detailed information, consult the manufacturer's handbook that accompanies this manual.
7. Use plastic bags and water-resistant adhesive tape to seal the air intake opening, all exhaust manifold openings, engine oil filler cap, hydraulic oil tank breather cap, and fuel tank caps.
8. Disconnect and remove battery or batteries. Completely clean and charge the batteries. Coat the terminals with petroleum jelly and store battery in cool, dry place.
9. Thoroughly clean the sprayer. Touch up any painted surfaces that are scratched or chipped. For touch-up paint recommendations contact the Hagie Manufacturing Customer Support Department.
10. Replace worn or missing decals. See pages 8-12 for proper location of warning decals and their corresponding part number. Warning decals and all other Hagie decals are available through the Hagie Manufacturing Customer Support Department.

NOTE:

For replacement decals contact:
Hagie Manufacturing Company
Box 273, Clarion, IA 50525
Ph. 1-800-247-4885

VIII. STORAGE

11. Use a multi-purpose grease to coat exposed hydraulic cylinder rods.
12. To winterize the spray system, it is recommended that you use an environmentally-safe type antifreeze and water mixture that will give you adequate protection to minus 30 degrees below zero. Drain any remaining solution in the system and run the antifreeze mixture through the spray system until it comes out all boom openings. Repeat the above process with both the foam marker and rinse systems.
13. If the sprayer must be stored outside, cover it with a waterproof cover.

B. Removing the sprayer from storage.

1. Inspect the condition, and test the air pressure, of all tires. Please see page 80 for information regarding proper tire maintenance.
2. Carefully unseal all openings that were sealed in the storage process.
3. Clean and reinstall the battery. Be sure to attach the battery cables to the proper terminals.
4. Tighten all belts. Inspect and replace any worn belts. For information on belts, see page 74.
5. Check engine oil, hydraulic oil, and engine coolant levels; add, if necessary. A mixture of 50/50 antifreeze and water will cool adequately in summer as well as protect in winter.

NOTE:

Protective compounds such as grease can harden under exposure to weather conditions.

6. Completely clean the sprayer.
7. Review section 7 on maintenance (pages 58-81), and perform all needed services as instructed.
8. For starting instructions, see pages 20-21 in section 4 on operating information.

NOTE:

See Warranty on page 93 concerning **improper storage**.

IX. TROUBLE SHOOTING

A. ENGINE

 **CAUTION**

Start engine from operator's seat only. When running engine in a building, be sure there is adequate ventilation.

PROBLEM	POSSIBLE CAUSE	SUGGESTED REMEDY
Engine won't crank	Dead battery Poor battery connections Starter or starter relay	Recharge or replace battery Clean and tighten Test; rebuild or replace
Engine won't start	Out of fuel Clogged fuel filters Cold weather Low starter speed	Fill fuel tank Replace fuel filters Refer to engine manual for cold weather starting information Check starter and battery

IX. TROUBLE SHOOTING

PROBLEM	POSSIBLE CAUSE	SUGGESTED REMEDY
Engine overheats	<p>Engine overloaded</p> <p>Dirty radiator core or dirty grill screen</p> <p>Faulty radiator cap</p> <p>Loose or faulty fan belt</p> <p>Faulty thermostat</p> <p>Low coolant level</p>	<p>Reduce load</p> <p>Remove all foreign material and clean all items</p> <p>Replace cap</p> <p>Tighten or replace fan belt</p> <p>Replace thermostat</p> <p>Refill to proper level with recommended coolant</p>
Engine misfires: runs uneven, low power	<p>Water in fuel</p> <p>Dirty air cleaner element</p> <p>Poor grade of fuel</p> <p>Fuel tank vent clogged</p> <p>Clogged fuel filter</p>	<p>Drain, flush, replace filter, fill system</p> <p>Replace element</p> <p>Drain system; change to good grade</p> <p>Open fuel tank vent in cap</p> <p>Replace fuel filter</p>
Engine knocks	<p>Low oil level in crankcase</p> <p>Cold engine</p>	<p>Add oil to full mark</p> <p>Allow proper warm-up period; refer to engine owner's handbook</p>

NOTE:

For additional engine information, consult engine manufacturer's manual.

IX. TROUBLE SHOOTING

B. SPRAY SYSTEM

 **WARNING**
CHEMICALS ARE DANGEROUS
Read The Chemical manufacturer's labels to avoid injury or damage.

PROBLEM	POSSIBLE CAUSE	SUGGESTED REMEDY
Solution pump will not prime	Low water level in pump Air leak in suction line Solution tank valve closed	Making sure the solution tank is not empty, solution pump is self-priming Inspect and tighten all fittings on suction line Open solution tank valve, allowing air to leave the system
Erratic reading on pressure gauge	Orifice in back of gauge clogged Faulty gauge Air leak in suction line Glycerin leaking from gauge	Remove gauge; clean orifice; re-install Replace gauge Inspect and tighten all fittings in suction line Replace gauge

IX. TROUBLE SHOOTING

PROBLEM	POSSIBLE CAUSE	SUGGESTED REMEDY
Solution pump not producing normal pressure	Clogged line strainer screen	Remove screen; clean thoroughly; tighten strainer cap to avoid air leak
	Air leak in suction flow to pump	Inspect and tighten all fittings on suction line
	Restricted solution flow to pump	Main solution tank shut-off valve not completely open
	Suction hose collapsed	Obstruction at inlet end of hose, causing high vacuum on hose
	Faulty hydraulic pump	Replace hydraulic pump
	Faulty hydraulic motor on solution pump	Replace motor
	Internal restriction of diaphragm such as build up of chemical	Disassemble; inspect; clean; reassemble
Malfunction of electric solution valve	Faulty ground	Clean and tighten ground
	Dirty contact terminals	Clean contact terminals
	Separation in wire	Check continuity and replace wire
	Faulty switch	Replace switch
	Short in solenoid coil	Replace valve
	Bad valve	Replace valve

NOTE:

If your unit is equipped with a high-pressure system, call the Hagie Manufacturing Customer Support Department for possible causes and suggested remedies.

IX. TROUBLE SHOOTING

C. HYDROSTATIC SYSTEM



CAUTION

DO NOT GO NEAR LEAKS. High pressure oil easily punctures skin causing injury, gangrene, or death. If injured, seek emergency medical help. Immediate surgery is required to remove oil. Do not use finger or skin to check for leaks. Lower load or relieve hydraulic pressure before loosening fittings.

PROBLEM	POSSIBLE CAUSE	SUGGESTED REMEDY
Machine won't move in either direction	Engine speed too low Oil level in reservoir low Clogged filter Hydrostatic pump not turning Faulty hydrostatic pump Air leak in suction line Low charge pressure Cruise is set to low	Set engine at operating RPM before trying to move machine Fill reservoir to proper level w/ approved oil; see section on Service and Maintenance Replace filter Check drive coupling Replace pump Inspect and tighten all fittings on suction line See section under charge pressure Adjust knob for cruise
Machine will move in only one direction	Faulty high pressure relief valve	Switch relief valves from side to side; If problem reverses, replace multi-function valve (Call Hagie Customer Support and refer to parts manual)

IX. TROUBLE SHOOTING

PROBLEM	POSSIBLE CAUSE	SUGGESTED REMEDY
Hydrostatic system responding slowly	<p>Engine speed too low</p> <p>Oil level in reservoir low</p> <p>Cold oil</p> <p>Plugged filter</p> <p>Partially restricted suction line</p> <p>Internal damage</p>	<p>Set engine at operating RPM before trying to move machine</p> <p>Fill reservoir to proper level with approved oil; see section on Service and Maintenance</p> <p>Allow for adequate warm-up period</p> <p>Check and replace filter</p> <p>Inspect for collapsed suction hose</p> <p>Replace hydrostatic pump or motor</p>
Noisy hydrostatic system	<p>Cold oil</p> <p>Low engine speed</p> <p>Oil level in reservoir low</p> <p>Air in system</p> <p>Internal damage to pump</p>	<p>Allow for adequate warm-up period</p> <p>Increase engine speed</p> <p>Fill reservoir to proper level with approved oil; see section on Service and Maintenance</p> <p>Inspect and tighten all fittings on suction line</p> <p>Replace pump</p>
External oil leaks	<p>Loose or faulty fittings</p> <p>Damaged O-ring</p> <p>Faulty hose</p>	<p>Tighten or replace</p> <p>Inspect; if damaged replace</p> <p>Replace hose</p>

IX. TROUBLE SHOOTING

D. HYDRAULIC SYSTEM



CAUTION

DO NOT GO NEAR LEAKS. High pressure oil easily punctures skin causing injury, gangrene, or death. If injured, seek emergency medical help. Immediate surgery is required to remove oil. Do not use finger or skin to check for leaks. Lower load or relieve hydraulic pressure before loosening fittings.

PROBLEM	POSSIBLE CAUSE	SUGGESTED REMEDY
Entire hydraulic system fails to function	<p>Oil level in reservoir low</p> <p>Oil not reaching pump</p> <p>Faulty hydraulic pump</p>	<p>Fill reservoir to proper level with approved oil; see section on Service and Maintenance</p> <p>Prime the pump by removing suction hose from reservoir; hold removed end higher than pump; hand feed two (2) quarts approved oil through suction hose by bumping engine w/ starter (careful not to start engine); re-install hose; tighten all fittings</p> <p>Replace hydraulic pump</p>
Noisy hydraulic pump	<p>Collapsed suction hose caused by cold oil</p> <p>Oil level in reservoir low</p> <p>Air leak in suction line</p>	<p>Allow for adequate warm-up period</p> <p>Fill reservoir to proper level with approved oil; see section on Service and Maintenance</p> <p>Inspect and tighten all fittings on suction hose</p>

IX. TROUBLE SHOOTING

E. ELECTRICAL

 CAUTION
 Batteries contain sulfuric acid. Avoid contact with skin, eyes, or clothing. Do not inhale fumes or ingest liquid. Batteries contain gases which can explode. Keep sparks and flame away while servicing.

NOTE:
 Disconnect battery when servicing any part of electrical system to prevent system damage.

PROBLEM	POSSIBLE CAUSE	SUGGESTED REMEDY
Entire electrical system is dead Ignition switch is off	Dead battery Poor battery connection Low charging rate No charging rate	Charge or replace Clean and tighten Tighten alternator belt Replace alternator
Light system does not function	Poor ground Burned-out bulb Separation or short in wire Faulty switch	Clean and tighten ground Replace bulb Check continuity and replace wire Replace switch

IX. TROUBLE SHOOTING

NOTES

X. LIMITED WARRANTY

1. The Warranty

- a. This warranty gives you specific legal rights. You may also have other rights which may vary from state to state.
- b. Hagie makes this warranty only to the original purchaser of its new equipment.
- c. The warranty period ends 12 months from the date of delivery of equipment to the original purchaser. When requesting warranty service, the original purchaser must present evidence of the date of delivery of the equipment.
- d. Parts or rebuilt assemblies furnished under the terms of this warranty are not warranted beyond the original warranty period.
- e. Exceptions to this warranty must be covered by separate warranty agreements.

2. Items not covered by Hagie Warranty

- a. Used equipment.
- b. Tires, tubes, engines, and batteries (under separate manufacturer's warranty).
- c. Depreciation or damage caused by normal wear, accident, improper maintenance, improper storage, or improper use.
- d. Service calls and transporting the equipment to and from the place where the warranty work is performed.

3. Unapproved service or modification

NOTE:

All obligations of Hagie Manufacturing Company under this warranty shall be terminated if:

- a. . . . service is performed by someone other than Hagie authorized personnel.
or
- b. . . . the equipment is modified or altered without Hagie approval.

4. No commercial loss coverage

- a. Hagie shall not be liable for incidental or consequential damages or injuries (damage and repairs of equipment itself, loss of profits, rental or substitute equipment, loss of good will, etc.).
- b. SOME STATES DO NOT ALLOW THE EXCLUSION OR LIMITATION OF INCIDENTAL OR CONSEQUENTIAL DAMAGES, SO THE ABOVE LIMITATION MAY NOT APPLY TO YOU.

5. Merger clause

- a. The entire warranty agreement is included in this writing.
- b. Any oral agreements that are made by the selling persons about the equipment are not warranties, and are not to be relied upon by the purchaser.

6. No representations or implied warranty

- a. The parties agree that the implied warranties of merchantability and fitness for a particular purpose and all other warranties expressed or implied, are excluded from this transaction and shall not apply to the equipment sold.

INDEX

	PAGE		PAGE
A		F	
Air Conditioning System		Fence Row	
Belt	74	L.E.D. Indicator	39
Cab Filters		Operation	39
Fresh Air Intake	70	Switch	39
Charcoal	70	Filter Minder®	67
Recirculation	70	Filters	
Charging System	66	Cab	70
Air Suspended Seat	53	Engine Air Intake Filter	67
Agitation System	42	Fuel Filter	70
Antifreeze	64	Hydraulic Charge Pressure Filter	68
B		Hydraulic High-Pressure In-Line Filter	69
Batteries		Hydraulic Suction Filters	68
Charging Auxiliary Posts	72	Solution Line Strainer	69
Service Access	72	Radiator Grille Screen	68
Belts		Fluid Capacities	66
Engine		Fluids	
Removal	74	Air Conditioning Charge	66
Inspection	74	Cooling System Coolant	64
A/C Compressor	74	Engine Oil	62
Boom		Fuel	65
Configuring 80' to 90'	34	Hydraulic Oil	62
Cradling	33	Torque Hub® Oil	63
Operation	28-34	Windshield Washer	66
C		Foam Marking System	
Cab	50	Adjusting System Pressure	43
Emergency Exit	51	Operation	43
Filters		System Pressure Gauge	43
Charcoal Filter	70	Wet Tank	79
Fresh Air Intake Filter	70	Fuel Filter	70
Recirculation Filter	70	H	
Calibration		High Pressure In-Line Filter	69
Monitor54		Hydraulic Tread Adjust	
Testing	54-55	Bearing Adjustment	76
Circuit Breakers	73	Operation	26
Cooling System		Tread Width Indicators	26
Coolant	64	Hydrostatic Drive System	23
Radiator Grille Screen	68	L	
E		L.E.D. Indicators	
Electrical System		Boom Solution Valve	37
Batteries		Fence Row Nozzle	39
Charging Auxiliary Posts	72	Lights	
Service Access	72	Field Lights	47
Circuit Breakers	73	Hazard/Warning Lights	49
Engine		Highway Lights	47
Fuel	65	Running Lights	49
Filter	70	Turn Signal	49
Oil	62	Work Lights	48
Operation	21-22		

INDEX

	PAGE		PAGE
Lubrication	71	Spray System	
Limited Warranty	93	Boom Solution Valves	37
Lug Nuts	75	L.E.D. Indicators	
		Boom Solution Valves	37
M		Fence Row Nozzle	39
Maintenance Schedule	58-61	Maintenance	
Message Center	52	Nozzle Inspection	
		Diaphragm	79
O		Spray Tip	79
Operating Information	20-53	Operating Instruction	35
		Solution Pump	
P		Pressure	36
Parking Brake	24	Switch	36
Pressure Gauges		Solution Switches	
Foamer System Air Pressure	43	Boom Solution Switches	37
Solution Spray System Pressure	36	Main Solution Switch	38
		T	
Q		Table of Contents	3
Quick Fill, Solution	40	Tires	
		Air Pressure	80
R		Filling	80
Radiator Grille Screen	68	Mounting	80
Rinse System	45	Specifications	19
		Toe-In	
S		Adjusting	78
Safety		Checking	77
Chemical Handling Safety	7	Torque Values	
Driving Safety	4	Tread Adjust Bearing	76
General Safety	7	Wheel Lug Nuts	75
Operating Safety	5	Transporting Sprayer	56-57
General Operating Safety	5	Tread Width	
Spray Boom Safety	5	Adjusting	26
Tread Width Safety	6	Hydraulic	26
Repair/Maintenance Safety	6	Manual	27
Fuel Safety	6	Indicators	26
General Repair Safety	6	Trouble Shooting Guide	84-92
Hydraulic Safety	6	W	
Serial Number Location		Warning Decal Location	8-12
Engine	13	Warning Symbol Definitions	2
Hydrostatic Pumps	14	Warranty	93
Sprayer	13	Wet Tank	79
Torque Hubs®		Wheel Lug Nuts	75
Front	14	Windshield Washer/Wiper	
Rear	14	Reservoir	66
Wheel motors		Switch	52
Front	14	Winter Storage Directions	82-83
Rear	14		
Service/Maintenance	58-81		
Solution Line Strainer	69		
Solution Pump	36		
Specifications	15-19		
Spray Booms			
Configuring 80' to 90'	34		
Cradling	33		
Operation	28-34		

NOTES
