

PARTS MANUAL
FOR
HAGIE MODEL STS 12 HI-TRACTOR

HAGIE MANUFACTURING COMPANY

BOX 273 CLARION, IOWA 50525

(515) 532-2861

COVERS MACHINE SERIAL NUMBERS: U1600220001 thru U1600220100

10-01 493252
02-08

SPRAYER IDENTIFICATION

Each Hagie sprayer is identified by means of a frame serial number. This serial number denotes the model, the year in which it was built, and the number of the sprayer. As for further identification, the engine has a serial number and the planetary hubs have identification plates that describe the type of mount and gear ratio. To insure prompt, efficient service when ordering parts or requesting service repairs from Hagie Manufacturing Company, record the serial and identification numbers in the space provided below.

NOTE: Reference to left hand and right hand used throughout this manual refers to the position when seated in the operator's seat facing forward.

SPRAYER SERIAL NUMBER

ENGINE SERIAL NUMBER

PLANETARY HUB IDENTIFICATION NUMBERS

TABLE OF CONTENTS

ENGINE ASSEMBLY 4-11

RADIATOR AND OIL COOLER ASSEMBLY. 12

AIR DRYER ASSEMBLY. 13

FUEL AND OIL TANK ASSEMBLY. 14-15

BATTERY. 16

HI-PRESS FILTER ASSEMBLY 17

LADDER AND BRAKE VALVE ASSEMBLY 18-19

LEG ASSEMBLY 20-27

STEERING CYLINDER. 28

TIRE ASSEMBLY 29

HYDRAULIC TUBING 30-31

TREAD ADJUST ASSEMBLY 32-35

LADDER ASSEMBLY. 36-37

AIR TANK ASSEMBLY 38

ELECTRICAL BOXES 39-41

CAB ASSEMBLY. 42-45

SWITCH PANEL ASSEMBLY 46

ATI CONTROLER BOX ASSEMBLY 48

BOOM CRADLE 49

MIRROR BRACKETS 50-51

SHEET METAL 52-53

SERVICE PLATFORM. 54

SOLUTION TANK 55-57

SOLUTION PUMP AND ELECTRIC VALVES 58-75

SOLUTION HOISING 76-79

FOAMER TANK ASSEMBLY. 80-86

TRANSOM, BOOM, AND LIFT COMPONENTS. 87-102

PRESSURE WASHER OPTION. 103-106

SIDE FILL/CHEMICAL INDUCTOR OPTION. 107-111

FRONT FILL OPTION. 112

RADAR OPTION. 113

FENDER OPTION 114-115

DECALS. 116-117

HYDRAULIC SCHEMATIC 118-125

ELECTRICAL SCHEMATIC 126-140

ABBREVIATIONS 141

INDEX. 142

PARTS ORDER FORM. 145

ENGINE ASSEMBLY

DET. QTY PART NO. DESCRIPTION

1	1	316360	CUMM ENG,QSB5.9C,275@2500CMPSR
2	1	470118	1/4UNC X 3/4 FLANGE HEX BOLT
3	1	470121	1/4UNC HEX FLANGE LOCK NUT
4	12	473798	10MM LOCK WASHER
5	12	473818	10MM-1.50 X 40MM HEX BOLT
6	2	473767	6MM-1.00 HEX NUT
7	2	473768	6MM LOCK WASHER
8	2	291701	BATT CABLE,RED 40" 6GA 1/4-1/4
9	1	291704	BATT CABLE,BLK 172" 6GA3/8-3/8
10	2	520080	HOSE CLAMP NO 10 STAINLESS
11	2	520120	HOSE CLAMP NO 4 STAINLESS
12	1	611302	08P919-10FJX-10FJX-69 H/A
13	1	601467	HOSE, 5/8 X 69 HEATER
14	1	520121	CUSH HOSE CLAMP 1IN X 3/4W
15	1	711036	1/8MNPT-1/4 NYL TUBE FTG
16	1	800502	PUMP DRIVE,DIRECT SAE#3/C 23T
17	8	900128	3/8UNC X 3/4 HEX BOLT
18	8	920502	3/8 LOCK WASHER
19	1	601474	HOSE, 1/4 X 26 AIR
20	1	800503	DRIVE DISK ASSY,11.5" 23T SPL
21	1	316373	FUEL/WATER SEPERATOR (316360)
22	1	316378	FUEL TRANSFER PUMP FOR 316360

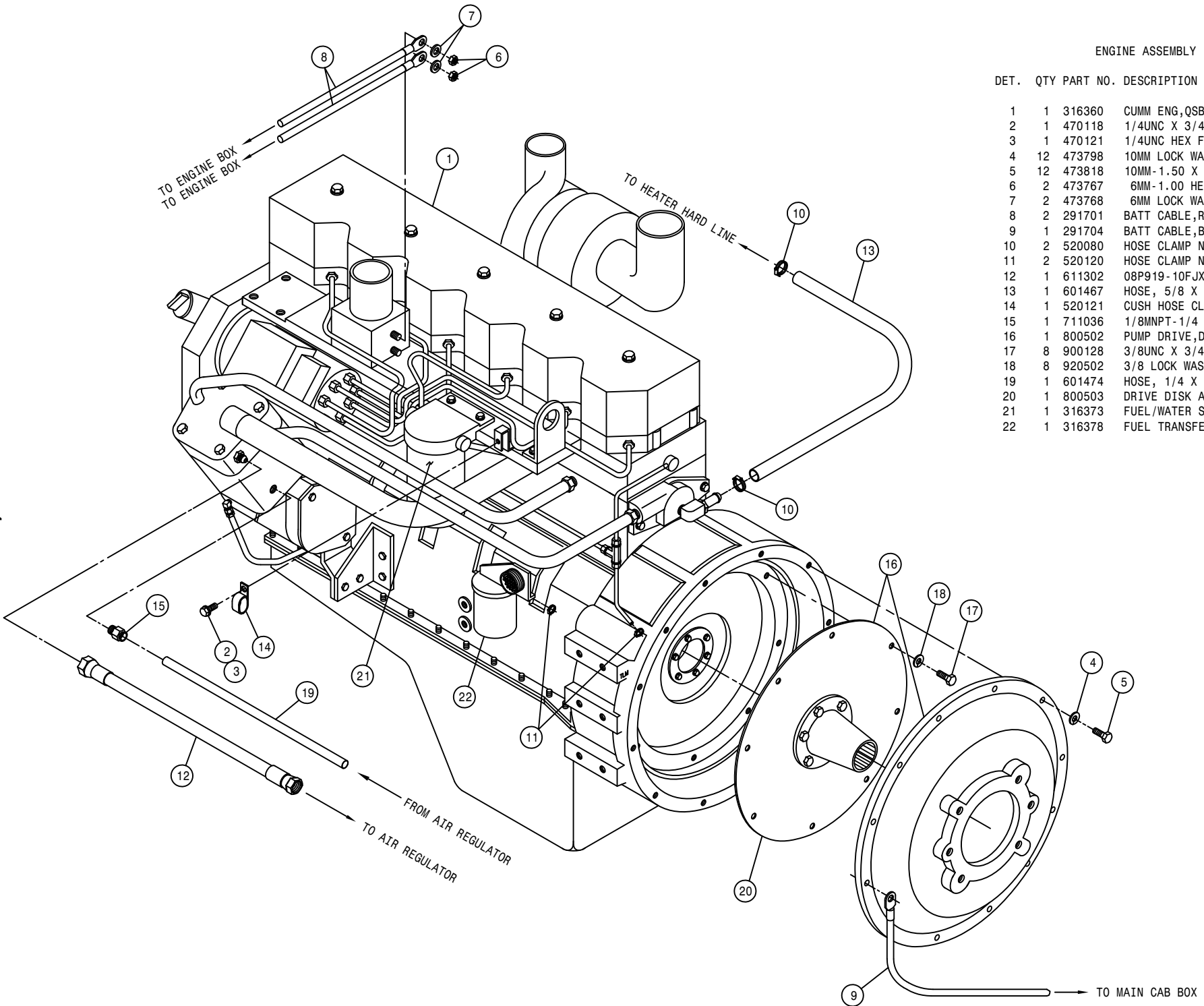

4

252004

ENGINE ASSEMBLY

DET. QTY PART NO. DESCRIPTION

1	1	314832	RADIATOR HOSE 1.75 X 19
2	1	314987	LWR RADIATOR HOSE STS-12
3	1	316360	CUMM ENG,QSB5.9C,275@2500CMPSR
4	1	316362	FAN SPACER, QSB5.9C STS12 00
5	1	316363	FAN, CUMM QSB5.9C, STS12 2000
6	1	316367	DELCO ALTERNATOR,130 AMP 22SI
7	1	316370	ALT PULLEY, 2.76 OD, 8-GROOVE
8	2	473766	10MM LOCK WASHER,INT TOOTH
9	4	473769	10MM-1.50 X 100MM FLG HEX BOLT
10	1	473770	5MM-.80 HEX NUT
11	1	473796	10MM-1.50 X 16MM HEX BOLT
12	4	473798	10MM LOCK WASHER
13	4	473799	10MM FLAT WASHER
14	1	291700	BATT CABLE,RED 31" 6GA 1/4-3/8
15	1	291706	BATT CABLE,RED 70" 2/0 3/8-3/8
16	1	291766	BATT CABLE,RED 48" 2/0 3/8-3/8
17	1	291708	BATT CABLE,BLK 73" 2/0 3/8-3/8
18	1	291763	BATT CABLE,BLK 33" 6GA 3/8-3/8
19	2	520067	HOSE CLAMP NO 28 STAINLESS
20	1	520069	HOSE CLAMP NO 6 STAINLESS
21	3	520080	HOSE CLAMP NO 10 STAINLESS
22	2	520099	HOSE CLAMP NO 40 STAINLESS
23	1	601468	HOSE, 5/8 X 91 HEATER
24	2	616137	12-421HT-12FJX-12FJX-68 H/A
25	1	316471	STARTER SOLENOID NUT ASSY
26	1	316372	LUBE FILTER (CUMM ENG 316360)
27	2	618302	1 1/16MJIC-90-1 5/16MOR LBO
28	1	316375	DRIVE BELT, QSB5.9C 316360 00
29	1	601529	HOSE, 3/4 X 34 CLEAR VINYL
30	2	618189	1 1/16MJIC-7/8MOR ADPTR
31	2	618191	1 1/16MJ-90-1 1/16FJ SWIV LBO
32	2	473827	8MM-1.25 X 20MM HEX BOLT
33	2	473804	8MM LOCK WASHER
34	1	316524	FAN, CUMM QSB5.9C, STS12 2002
35	1	316525	DRIVE BELT, QSB5.9C 316360 02

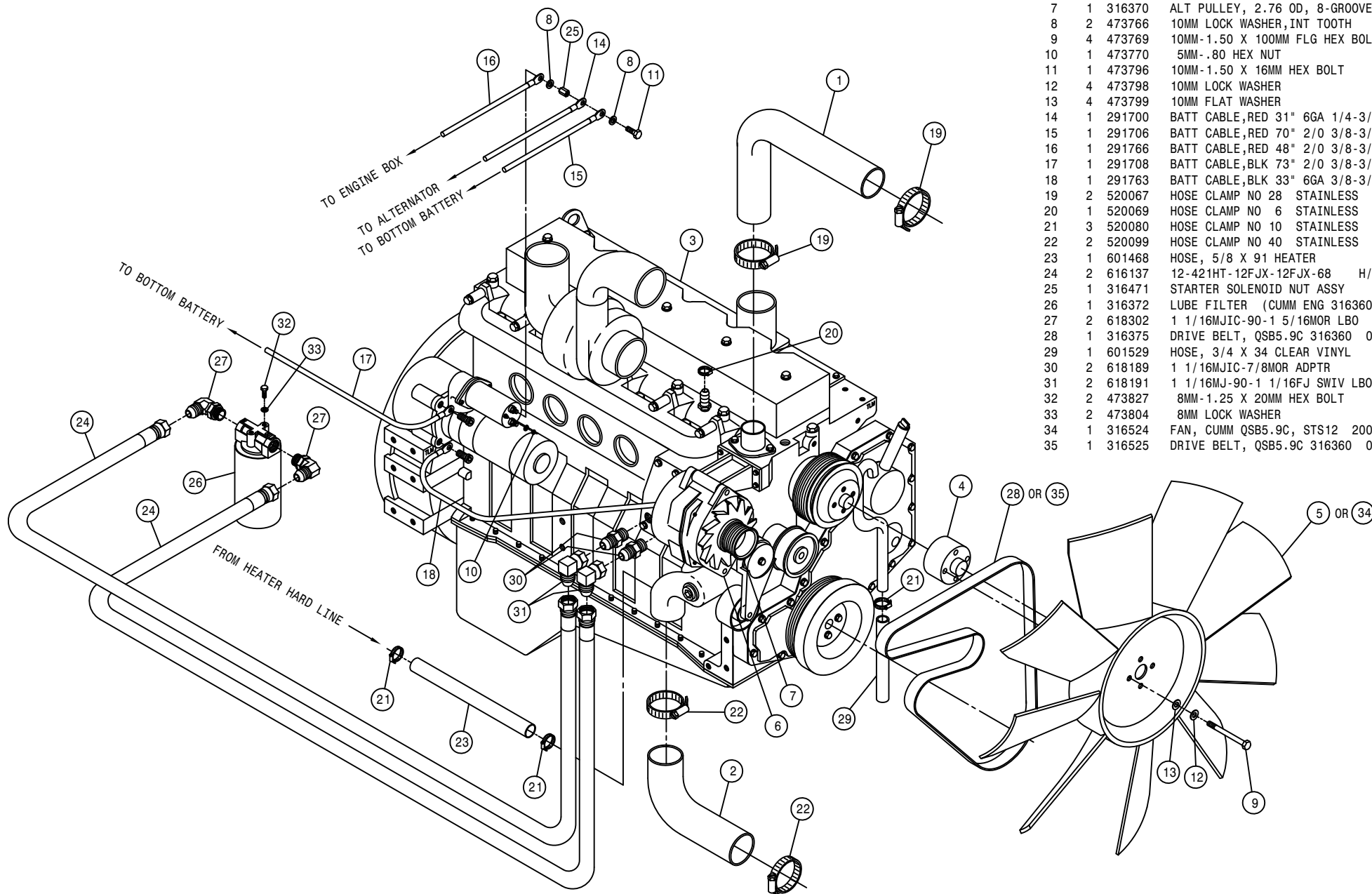

5

252005

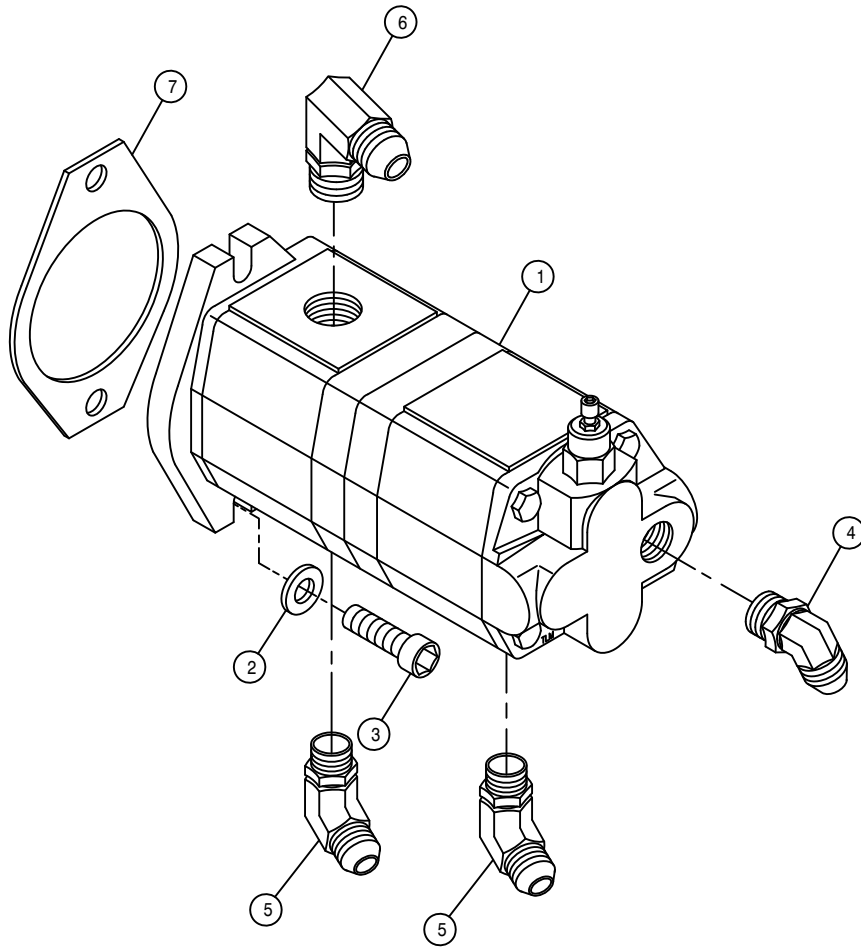

STEERING AND TREAD ADJUST PUMP ASSEMBLY

DET. QTY PART NO. DESCRIPTION

1	1	606990	TANDEM PUMP, .66CI/.51CI
2	2	473799	10MM FLAT WASHER
3	2	473844	10MM-1.50 X 30 SOC HD CAP SCR
4	1	618315	3/4MJIC-45-3/4MOR LBO
5	2	618183	3/4MJIC-90-7/8MOR LBO
6	1	618248	1 1/16MJIC-90-1 1/16MOR LBO
7	1	316371	GASKET, AUX DRIVE CUMM 154916

A/C COMPRESSOR PUMP ASSEMBLY

DET. QTY PART NO. DESCRIPTION

DET.	QTY	PART NO.	DESCRIPTION
1	1	147049	BELT, 9425 GATES
2	1	316461	A/C MTG BRKT WLD, STS 2000
3	3	473844	10MM-1.50 X 30 SOC HD CAP SCR
4	3	473798	10MM LOCK WASHER
5	2	483043	3/8 REGULAR FLAT WASHER
6	1	657450	A/C COMPSR,90D PORT TM15/12
7	4	900131	3/8UNC X 1 1/2 HEX BOLT
8	4	914004	3/8UNC HEX STOVER NUT
9	1	657446	A/C HOSE,08-08F90-08F90SV-65"
10	1	657447	A/C HOSE,10-10F90-10F90SV-92"
11	1	316522	A/C MTG BRKT WLD, STS 2002

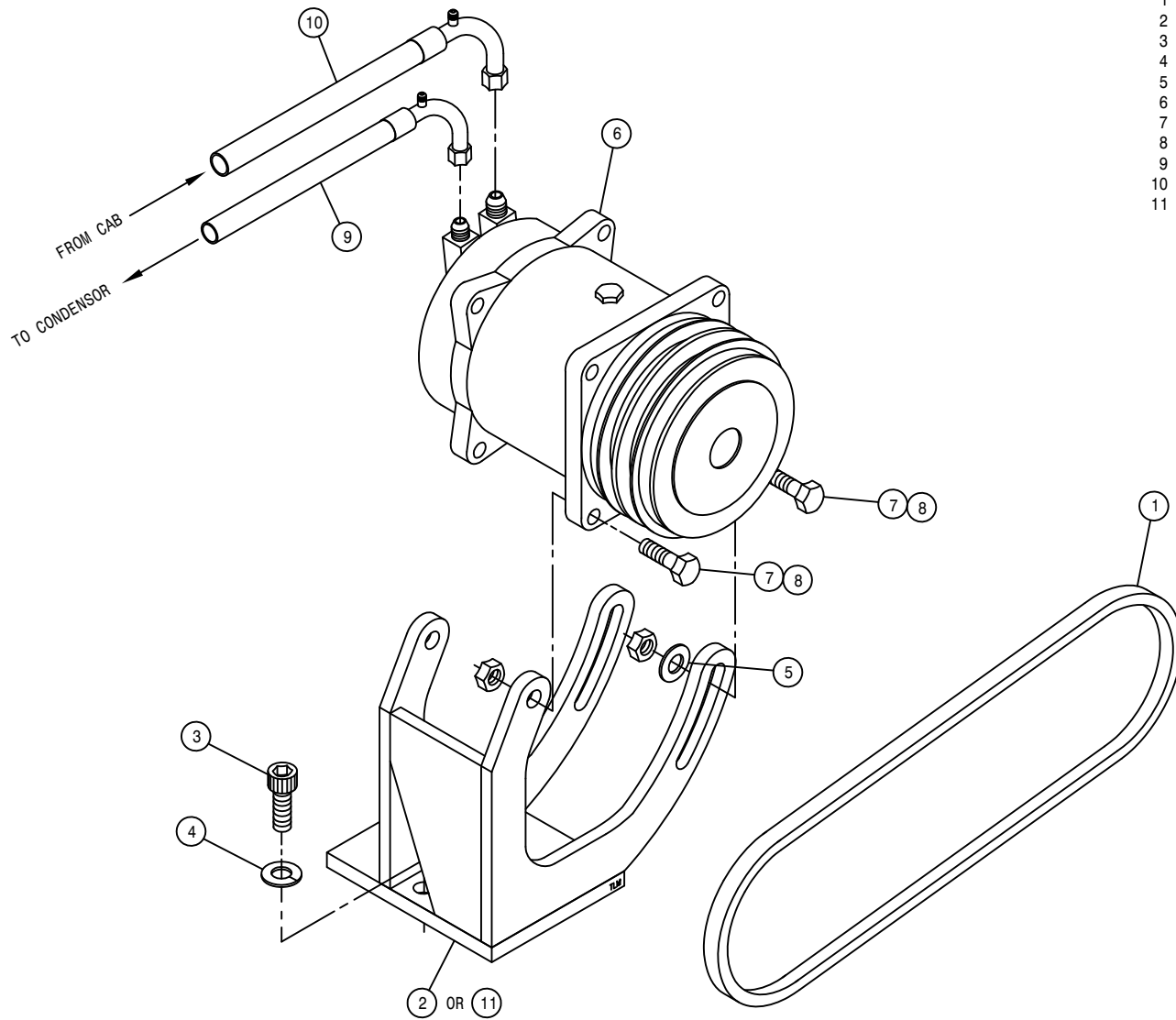

HYDROSTATIC PUMP ASSEMBLY

DET. QTY PART NO. DESCRIPTION

DET.	QTY	PART NO.	DESCRIPTION
1	1	606965	TANDEM PUMP, 606966 & 606969
2	1	606966	SUND 75CC PUMP,C/C-MT
3	1	606969	SUND 75CC PUMP,C/B-MT
4	1	606972	TANDEM PUMP, 606984 & 606987
5	1	606984	SUND GEAR PUMP,2.02CI GRP3
6	1	606987	SUND GEAR PUMP,.128CI GRP3
7	2	611127	1 1/16MJIC-1 1/16MOR ADPTR
8	1	614754	.050 ELBOW ASSY,9/16MOR 90D
9	1	618115	9/16MJIC-90-3/4MOR LBO
10	2	618126	9/16MJIC-9/16MOR ADPTR
11	2	618186	1 5/16MJIC-1 5/16MOR ADPTR
12	1	618191	1 1/16MJ-90-1 1/16FJ SWIV LBO
13	1	618302	1 1/16MJIC-90-1 5/16MOR LBO
14	4	618327	3/4MJIC-7/8MOR ADPTR
15	1	618444	9/16MOR RUN TEE-9/16MJIC
16	2	618451	3/4FJIC SW RUN TEE-3/4MJIC
17	1	618455	1 5/16MJIC-1 5/8MOR ADPTR
18	1	618531	9/16FJIC CAP NUT
19	1	618619	1 5/16FJ SW RUN TEE-1 5/16MJ
20	1	618640	1 5/16MJ-90-1 5/16FJ SWIV LBO
21	1	618641	1 1/16FJIC-1 5/16MJIC ADPTR
22	4	618652	1" SPLIT FLANGE KIT
23	3	618653	1" FLANGE-1 7/16MFOR ADPTR
24	1	618654	1" FLANGE-90-1 7/16MFOR LBO
25	4	618655	1 7/16FFOX RUN TEE-1 7/16MFOR
26	1	618660	1 1/16FJX BRANCH TEE-1 1/16MJ
27	1	618661	1 5/16FJIC-9/16MJIC ADPTR
28	4	618676	O-RING FOR 1" SPL FLG 618652
29	1	606870	O-RING FOR 606865 SUND B-MT
30	4	900265	1/2UNC X 1 1/2 HEX BOLT
31	4	920504	1/2 LOCK WASHER
32	4	920004	1/2 SAE FLAT WASHER
33	12	618677	O-RING,-16 FACE SEAL .93ID 90D

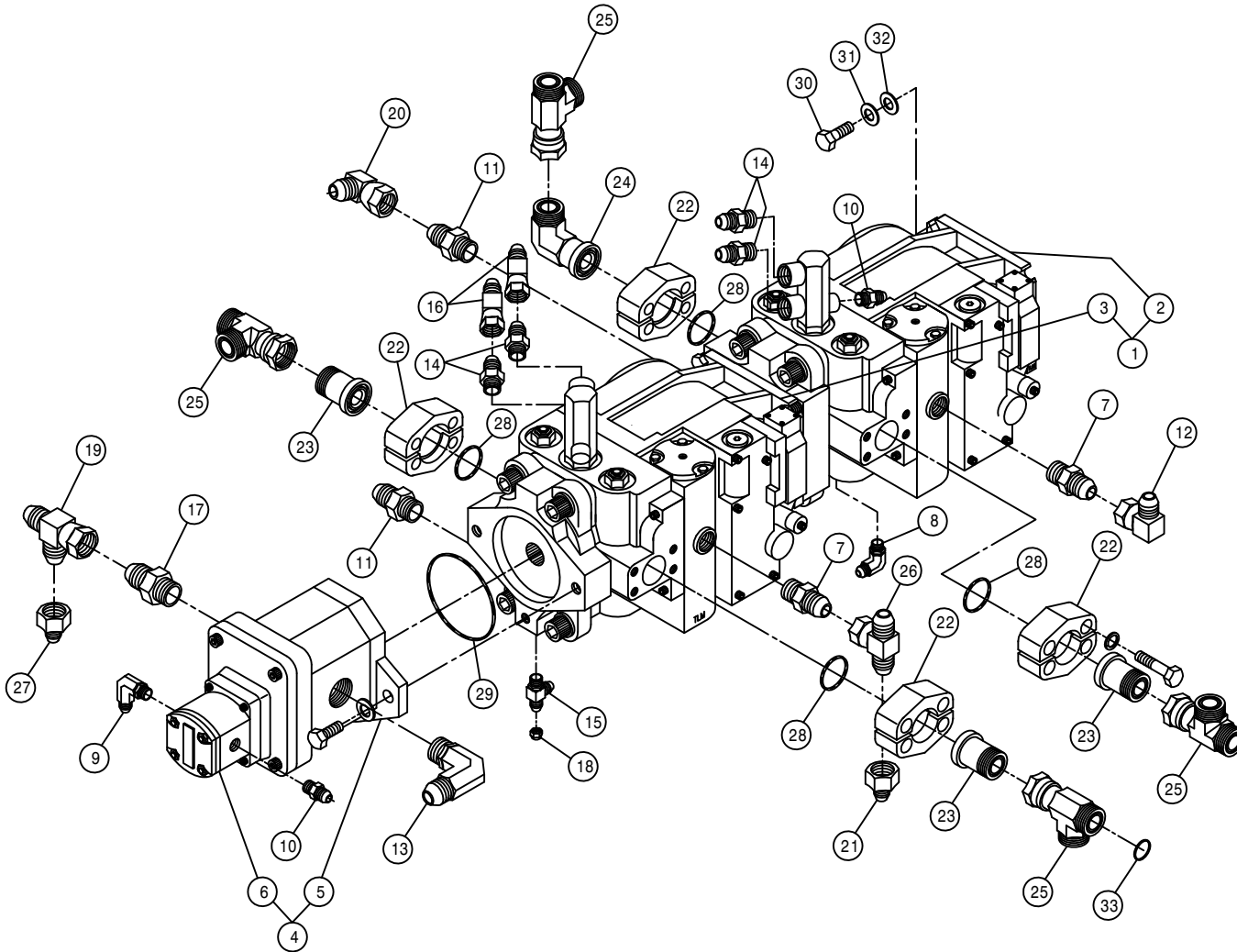

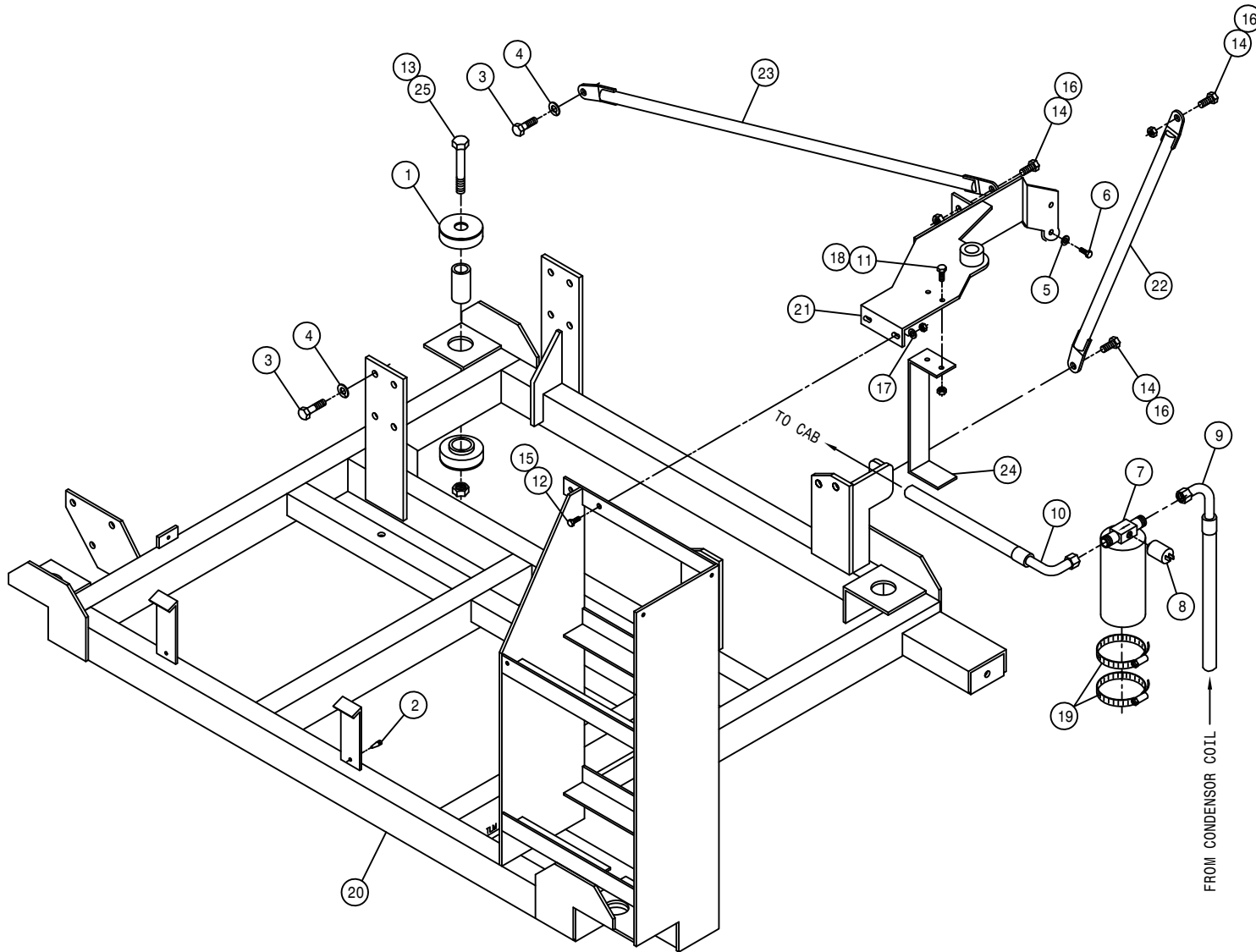

ENGINE SKID ASSEMBLY

DET.	QTY	PART NO.	DESCRIPTION
1	4	311057	RUBBER MT SET,SSB33-1000-4
2	4	470313	GROMMET BUMPER,1/4T X 1/4D MT
3	13	473775	12MM-1.75 X 30MM HEX BOLT
4	13	473874	12MM LOCK WASHER
5	2	473804	8MM LOCK WASHER
6	2	473827	8MM-1.25 X 20MM HEX BOLT
7	1	657421	A/C RECEIVER/DRIER
8	1	657422	A/C BINARY SWITCH
9	1	657443	A/C HOSE,06-06F90-06F90-34"
10	1	657444	A/C HOSE,06-06F90-06F90-115"
11	2	900065	5/16UNC X 1" HEX BOLT
12	2	900129	3/8UNC X 1" HEX BOLT
13	4	914012	3/4UNC HEX STOVER NUT
14	3	900264	1/2UNC X 1 1/4 HEX BOLT
15	2	914004	3/8UNC HEX STOVER NUT
16	3	914008	1/2UNC HEX STOVER NUT
17	2	920002	3/8 SAE FLAT WASHER
18	2	914002	5/16UNC HEX STOVER NUT
19	2	520052	HOSE CLAMP NO 52 STAINLESS
20	1	316380	SKID WLD
21	1	316426	RAD MT PLT WLD
22	1	316433	RH RAD BRACE WLD
23	1	316434	LH RAD BRACE WLD
24	1	316432	A/C DRYER MT
25	4	900408	3/4UNC X 3 1/2 HEX BOLT

AIR CLEANER ASSEMBLY

DET. QTY PART NO. DESCRIPTION

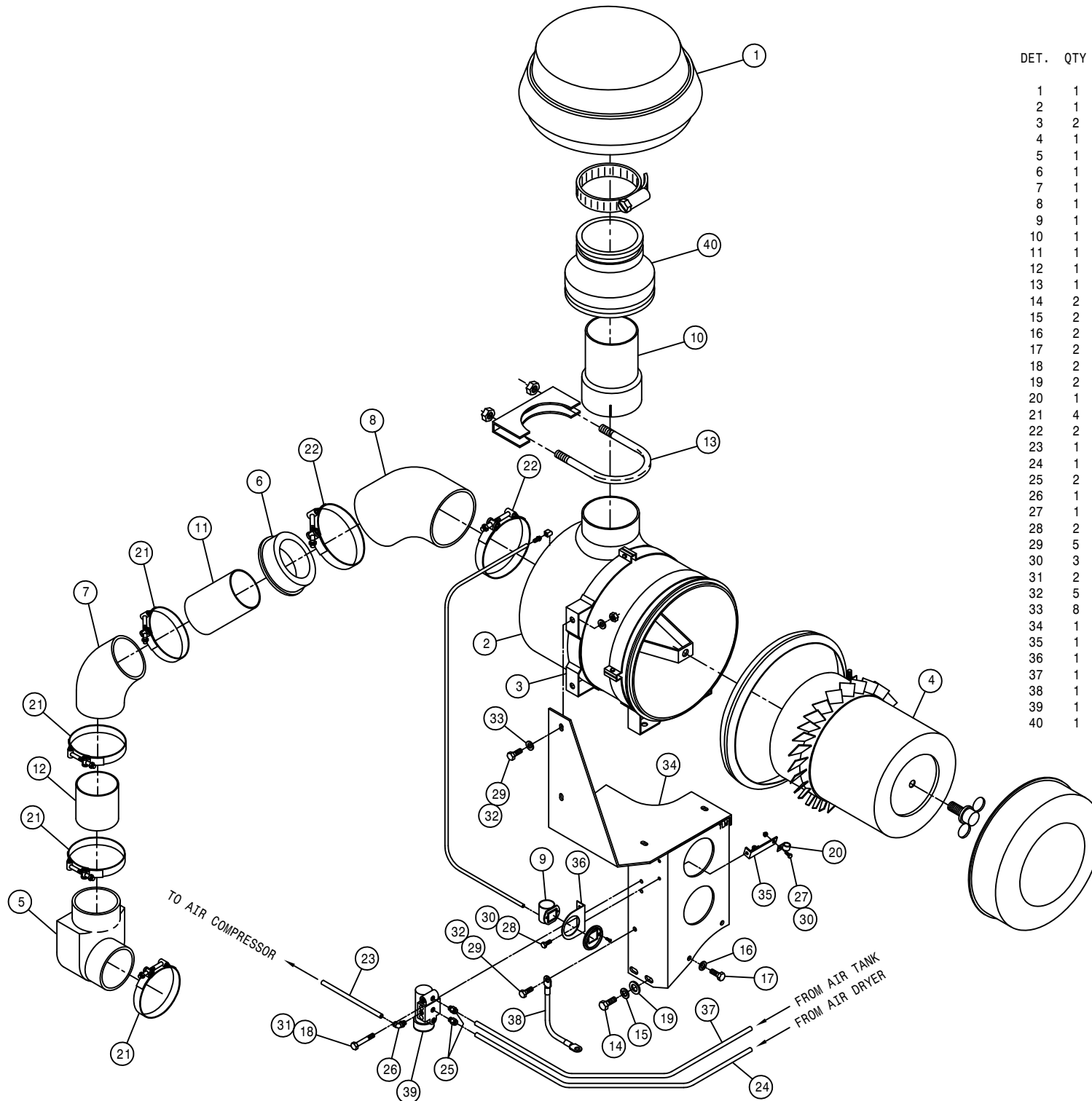

1	1	314971	AIR CLEANER HOOD FOR 314970
2	1	311502	AIR CLEANER, 14"
3	2	311503	AIR CLEANER MT BAND FOR 311502
4	1	311504	AIR FILTER FOR 311502
5	1	311505	4.00 90 DEG COBRA ELBOW,RUBBER
6	1	311506	5.50-4.00 ID REDUCER BUSHING
7	1	311507	4.00" 45DEG ELBOW, RUBBER
8	1	311508	5.50" 45DEG ELBOW, RUBBER
9	1	314901	FILTER MINDER AIR RESTRICT GA
10	1	314986	AIR CLEANER HOOD EXTEN,5"X8"LG
11	1	316068	4" X 6.00" AIR INTAKE TUBE
12	1	316344	4" X 4.00" AIR INTAKE TUBE 98
13	1	470260	MUFFLER CLAMP, 5.00
14	2	473775	12MM-1.75 X 30MM HEX BOLT
15	2	473784	12MM LOCK WASHER
16	2	473798	10MM LOCK WASHER
17	2	473818	10MM-1.50 X 40MM HEX BOLT
18	2	900072	5/16UNC X 3" HEX BOLT
19	2	473843	12MM FLAT WASHER
20	1	520117	CUSH HOSE CLAMP 5/8D X 1/2W
21	4	520134	4.31/4.59 T-BOLT HOSE CLAMP SS
22	2	520144	5.94/6.21 T-BOLT HOSE CLAMP SS
23	1	601474	HOSE, 1/4 X 26 AIR
24	1	601475	HOSE, 1/4 X 47 AIR
25	2	711036	1/8MNPT-1/4 NYL TUBE FTG
26	1	711039	1/8MNPT-1/4 NYL TUBE LBO
27	1	900000	1/4UNC X 1/2 HEX BOLT
28	2	900002	1/4UNC X 3/4 HEX BOLT
29	5	900129	3/8UNC X 1" HEX BOLT
30	3	914000	1/4UNC HEX STOVER NUT
31	2	914002	5/16UNC HEX STOVER NUT
32	5	914004	3/8UNC HEX STOVER NUT
33	8	920002	3/8 SAE FLAT WASHER
34	1	316464	AIR CLEANER MT WLD
35	1	316468	DIPSTICK MTG BRKT
36	1	316469	FILTER MINDER GAUGE MT
37	1	601478	HOSE, 1/4 X 175 AIR
38	1	291703	BATT CABLE,BLK 12" 6GA 3/8-3/8
39	1	316277	AIR COMPRESSOR GOVERNOR KIT
40	1	311512	7.00-4.75 ID REDU BOOT,RUBBER

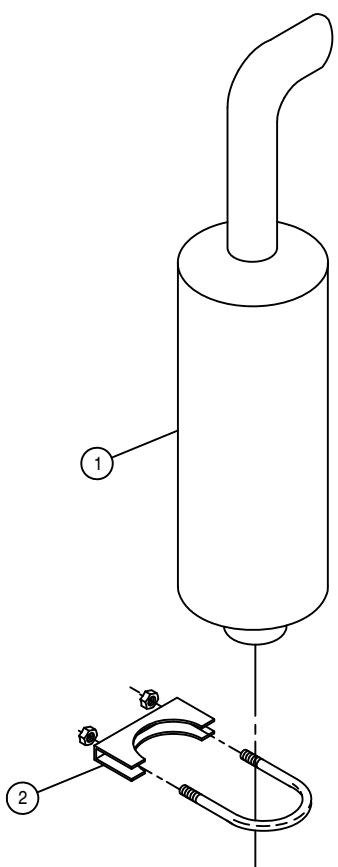

MUFFLER ASSEMBLY

DET.	QTY	PART NO.	DESCRIPTION
1	1	316366	MUFFLER, STS12
2	1	470160	MUFFLER CLAMP 3.00 IN

RADIATOR AND OIL COOLER ASSEMBLY

DET. QTY PART NO. DESCRIPTION

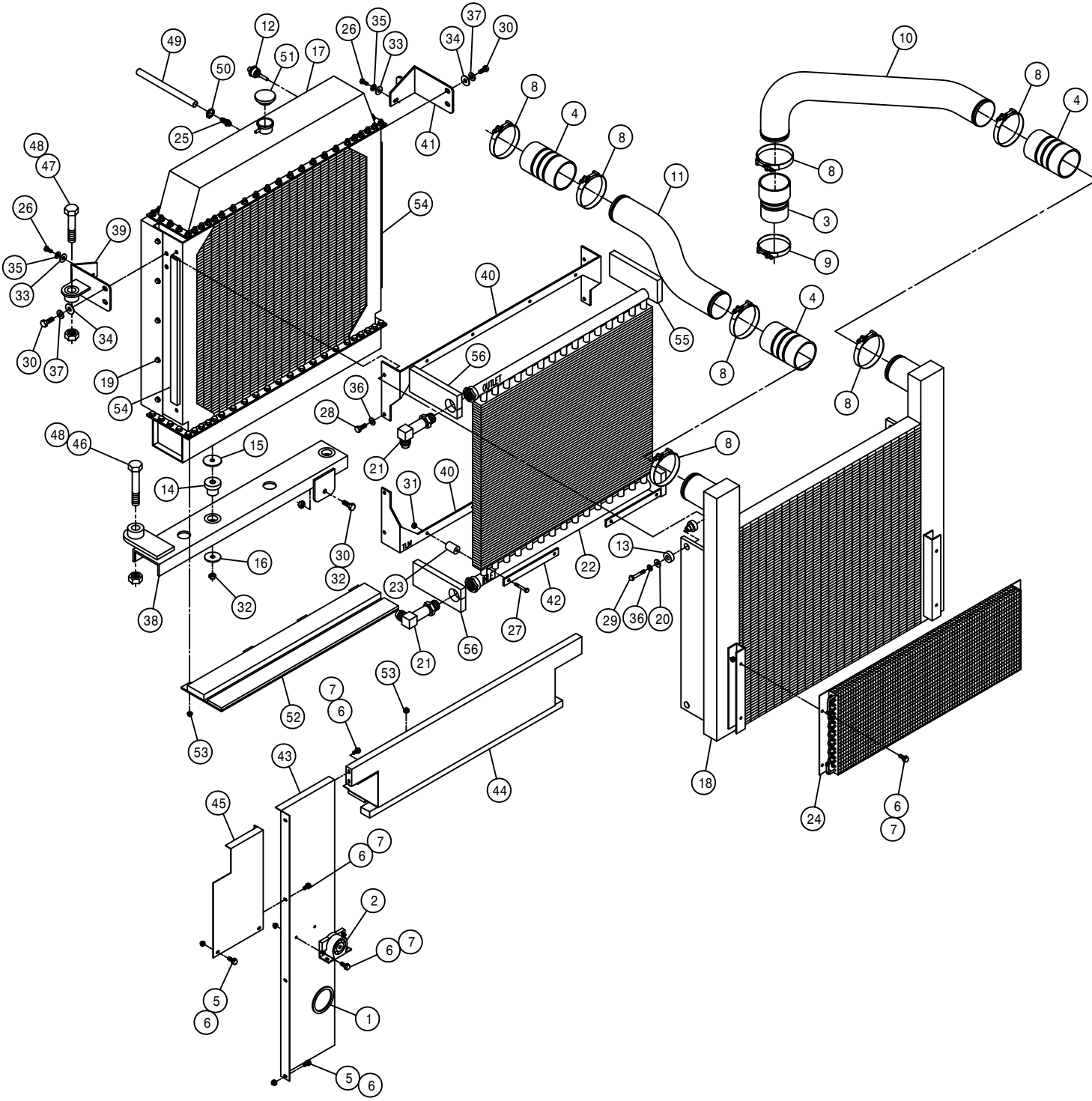

DET.	QTY	PART NO.	DESCRIPTION
1	1	193012	QUICKEDGE TRIM .135 TO .250
2	1	291759	BACK-UP WARNING BEEPER, 112DB
3	1	311500	3.00-3.50 CAC HOSE, AIR INTAKE
4	3	311501	3.50 CAC HOSE, AIR INTAKE
5	4	470118	1/4UNC X 3/4 FLANGE HEX BOLT
6	14	470121	1/4UNC HEX FLANGE LOCK NUT
7	10	470122	1/4UNC X 1/2 FLANGE HEX BOLT
8	7	520145	356 T-BOLT HOSE CLAMP SS
9	1	520146	306 T-BOLT HOSE CLAMP SS
10	1	316459	RIGHT CHARGE AIR COOLER PIPE
11	1	316460	RUBBER MOUNT,1-PC CB-1122-2
12	1	291714	WATER LEVEL SENSOR
13	4	311056	RUBBER MOUNT SET,2-PC CB 2320
14	2	311060	RUBBER MOUNT,1-PC CB-1122-2
15	2	311061	HEAD WASHER FOR 311060
16	2	311062	TAIL WASHER FOR 311060
17	1	316364	RADIATOR, STS12 2000
18	1	316365	CHARGE AIR COOLER, STS12 2000
19	10	470319	3/8UNC X 1/2 FLANGE HEX BOLT
20	4	483043	3/8 REGULAR FLAT WASHER
21	2	618463	1 5/16MJIC-90-1 5/16MOR XL LBO
22	1	618800	OIL COOLER STS12 2000
23	8	618801	MOUNTING KIT FOR 618800 COOLER
24	1	657434	A/C CONDENSER COIL 21-0302
25	1	783304	1/4 NPT X 3/8 HOSE BARB, BRS
26	2	900064	5/16UNC X 3/4 HEX BOLT
27	8	900071	5/16UNC X 2 3/4 HEX BOLT
28	4	900128	3/8UNC X 3/4 HEX BOLT
29	4	900133	3/8UNC X 2" HEX BOLT
30	5	900264	1/2UNC X 1 1/4 HEX BOLT
31	8	914002	5/16UNC HEX STOVER NUT
32	3	914008	1/2UNC HEX STOVER NUT
33	2	920001	5/16 SAE FLAT WASHER
34	4	920004	1/2 SAE FLAT WASHER
35	2	920501	5/16 LOCK WASHER
36	8	920502	3/8 LOCK WASHER
37	4	920504	1/2 LOCK WASHER
38	1	316439	RAD MT WLD
39	1	316447	UPPER LH RAD MT WLD
40	2	316452	RAD TO OIL COOLER MT
41	1	316446	UPPER RH RAD MT WLD 2000
42	4	316453	RAD TO OIL COOLER KEEPER
43	1	316457	BATTERY BOX FILLER PANEL
44	1	316487	UPR RADIATOR FILLER PANEL ASSY
45	1	316458	UPPER BATTERY BOX FILLER
46	1	900540	1" UNC X 7" HEX BOLT
47	1	900541	1" UNC X 3 3/4" HEX BOLT
48	2	914016	1" UNC HEX STOVER NUT
49	1	601472	HOSE, 3/8 X 24 HEATER
50	1	520069	HOSE CLAMP NO 6 STAINLESS
51	1	316377	RAD CAP, 10LB 10237
52	1	316490	LWR RADIATOR FILLER PANEL ASSY
53	8	470113	5/16UNC HEX FLANGE LOCK NUT
54	2	316493	SIDE FOAM,RAD/CAC
55	2	316494	RH UPR/LWR FOAM,OIL CLR/RAD 00
56	2	316495	LH UPR/LWR FOAM,OIL CLR/RAD 00

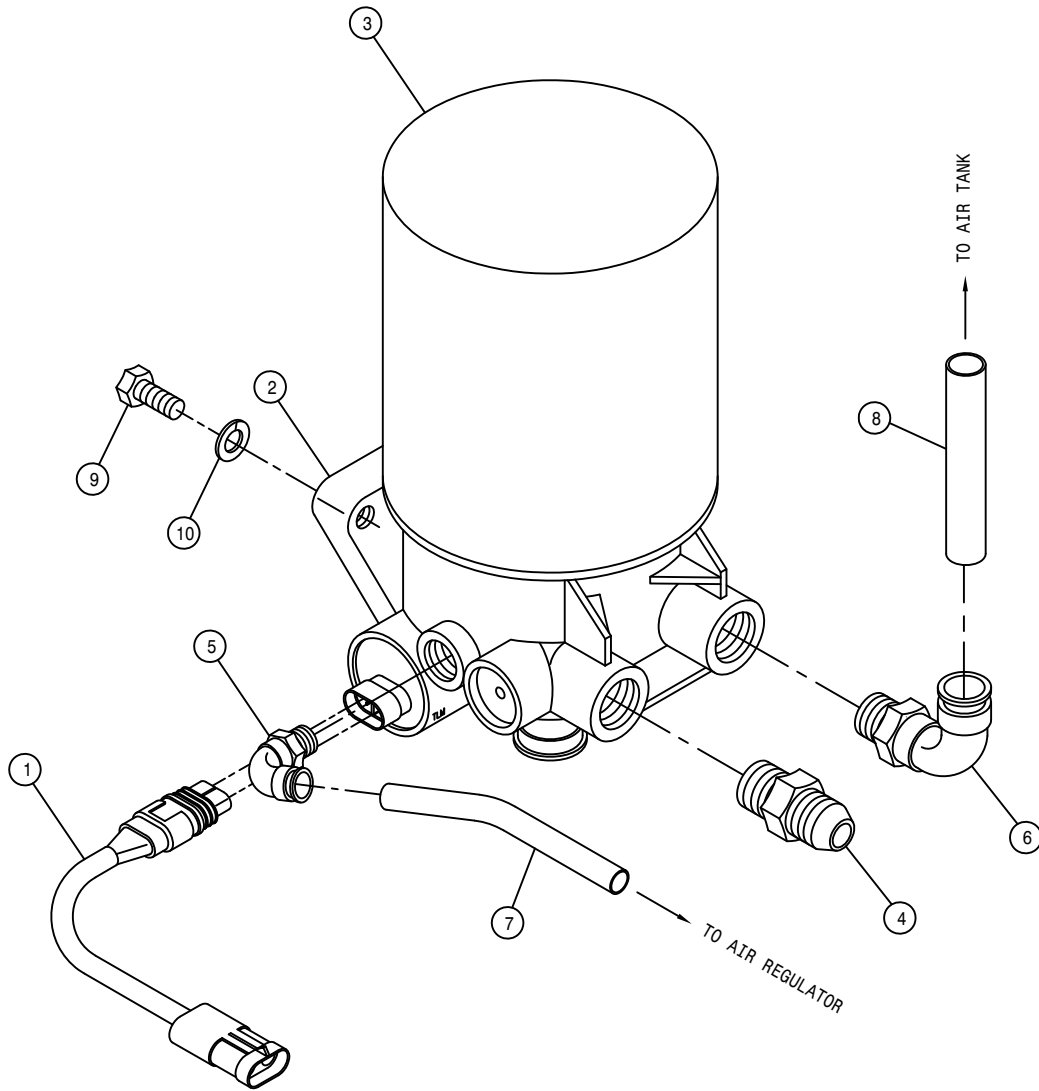

AIR DRYER ASSEMBLY

DET. QTY PART NO. DESCRIPTION

1	1	293517	AIR DRYER HARNESS
2	1	311072	AIR DRYER, AD-SP SYSTEM PURGE
3	1	311073	CARTRIDGE FOR AIR DRYER 311072
4	1	618325	7/8MJIC-1/2MNPT ADPTR
5	1	711040	1/4MNPT-1/4 NYL TUBE LBO
6	1	711042	1/2MNPT-1/2 NYL TUBE LBO
7	1	601475	HOSE, 1/4 X 47 AIR
8	1	601483	HOSE, 1/2 X 84 AIR
9	3	900265	1/2UNC X 1 1/2 HEX BOLT
10	3	920504	1/2 LOCK WASHER

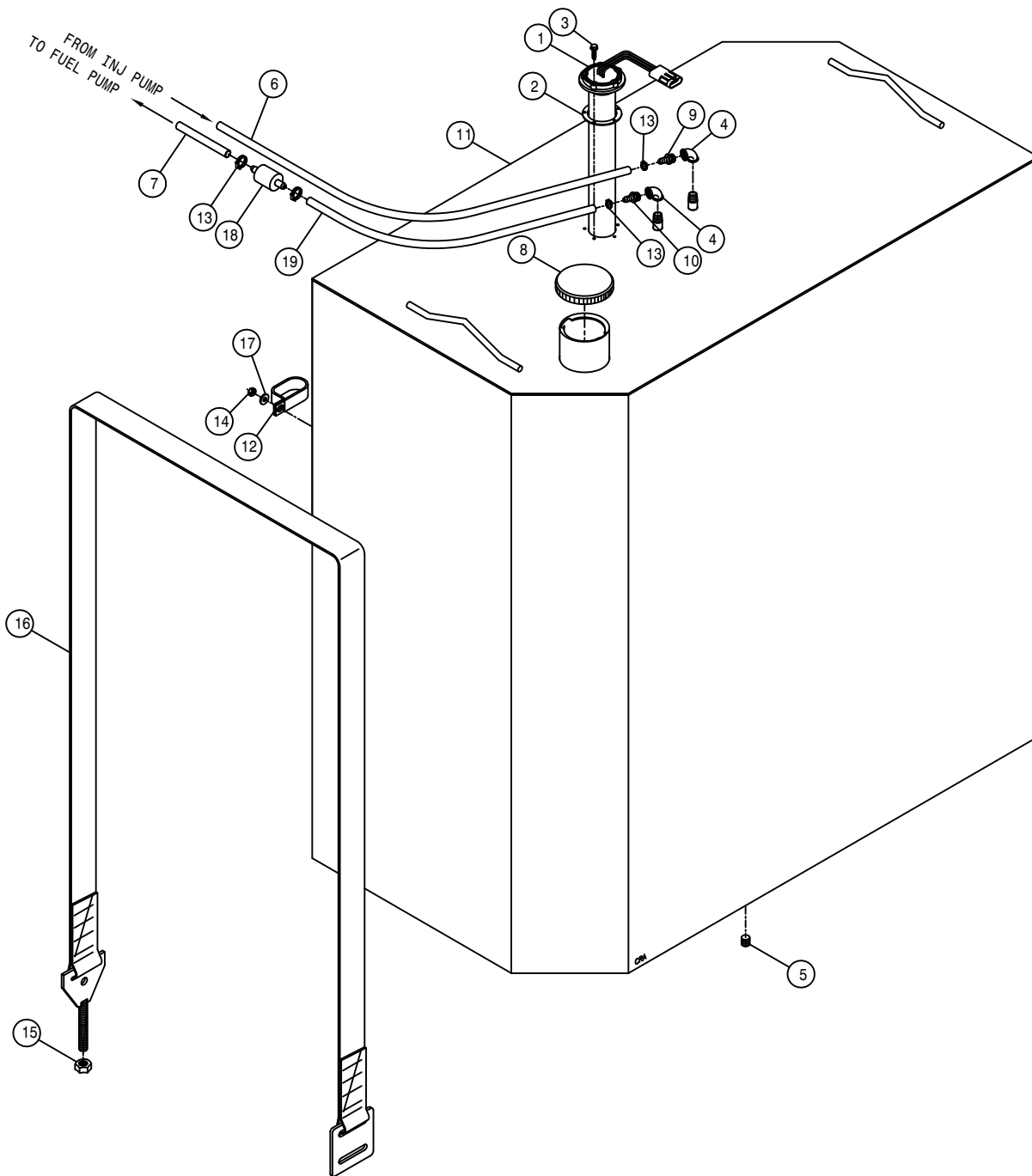

FUEL TANK ASSEMBLY

DET.	QTY	PART NO.	DESCRIPTION
1	1	291788	FUEL SENDER
2	1	291789	GASKET FOR FUEL SENDER 291788
3	5	472347	#10 X 1 1/4 SELF DRILL/TAP SCR
4	2	501451	BLK PIPE EL 90DEG .25NPT
5	1	503703	PIPE PLUG .50NPT SKT HD
6	1	601300	HOSE, 5/16 X 60 FUEL LINE
7	1	601550	HOSE, 3/8 X 22 FUEL LINE
8	1	761202	FUEL TANK CAP,3" VENTED,ZINCPL
9	1	783303	1/4 NPT X 5/16 HOSE BARB, BRS
10	1	783304	1/4 NPT X 3/8 HOSE BARB, BRS
11	1	760251	FUEL TANK WLD
12	1	520116	CUSH HOSE CLAMP 1IN DBL TUBE
13	4	520120	HOSE CLAMP NO 4 STAINLESS
14	1	914000	1/4UNC HEX STOVER NUT
15	2	914008	1/2UNC HEX STOVER NUT
16	2	316473	FUEL TANK HOLD-DOWN STRAP ASSY
17	1	920000	1/4 SAE FLAT WASHER
18	1	316281	FUEL STRAINER, IN-LINE, DIESEL
19	1	601551	HOSE, 3/8 X 38 FUEL LINE

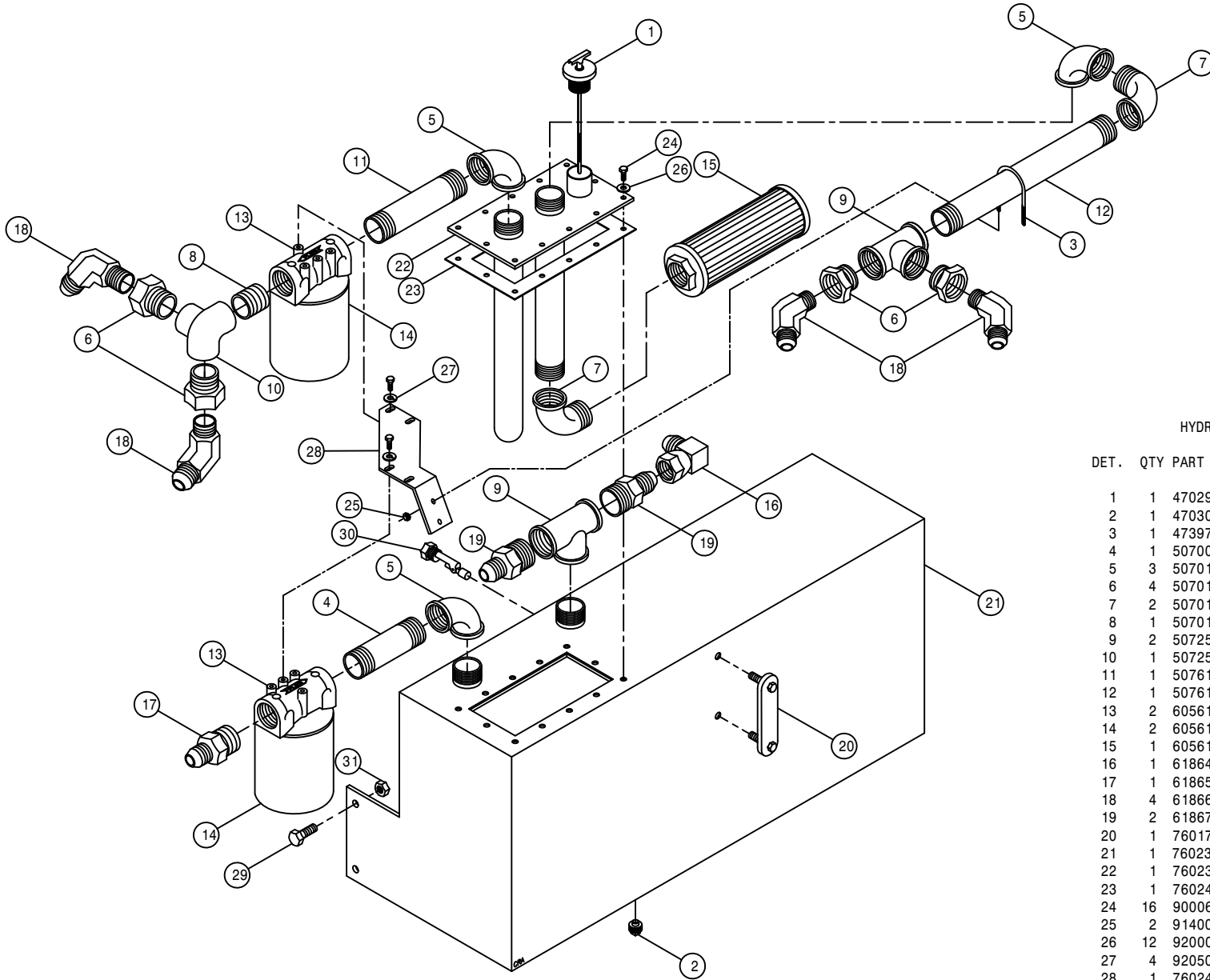

HYDRAULIC TANK ASSEMBLY

DET.	QTY	PART NO.	DESCRIPTION	
	1	470293	DIPSTICK, VENTED	
	1	470308	1/2MNPT DRAIN PLUG,AL HD,MAG	
	1	473971	1/4UNC-2"ID-3"RD U-BOLT	
	4	507009	BLK PIPE NIPPLE 1.50NPT-6.00	
	3	507014	BLK PIPE EL 90DEG 1.50NPT	
	4	507015	RED BUSH 1.50NPT - 1.25FNPT	
	7	2	507018	BLK PIPE ST EL 90DEG 1.50NPT
	8	1	507019	CLOSE NIPPLE 1.50NPT
	9	2	507250	BLK PIPE TEE 1.50NPT
	10	1	507252	SIDE OUTLET EL 90DEG 1.50NPT
	11	1	507610	BLK PIPE NIPPLE 1.50NPT-8.00
	12	1	507617	BLK PIPE NIPPLE 1.50NPT-16.00
	13	2	605611	FILTER HEAD, 1 1/2FNPTF ZINGA
	14	2	605612	FILTER, 10 MICRON ZINGA
	15	1	605613	TANK FILTER,100 MESH,1 1/2FNPT
	16	1	618640	1 5/16MJ-90-1 5/16FJ SWIV LBO
	17	1	618656	1 5/8MJIC-1 1/2MNPT ADPTR
	18	4	618667	1 5/16MJIC-45-1 1/4MNPT LBO
	19	2	618672	1 5/16MJIC-1 1/2MNPT ADPTR
	20	1	760177	SIGHT GAUGE W/TEMP, HYD TANK
	21	1	760231	HYD TANK WLD STS12
	22	1	760239	RECEIVER PLATE WLD STS12
	23	1	760243	GASKET, RECEIVER PLATE STS12
	24	16	900064	5/16UNC X 3/4 HEX BOLT
	25	2	914000	1/4UNC HEX STOVER NUT
	26	12	920001	5/16 SAE FLAT WASHER
	27	4	920501	5/16 LOCK WASHER
	28	1	760245	HYD FILTER KEEPER
	29	4	900264	1/2UNC X 1 1/4 HEX BOLT
	30	1	470350	LIQUID LEVEL SWITCH, 1/2MNPT
	31	4	914008	1/2UNC HEX STOVER NUT

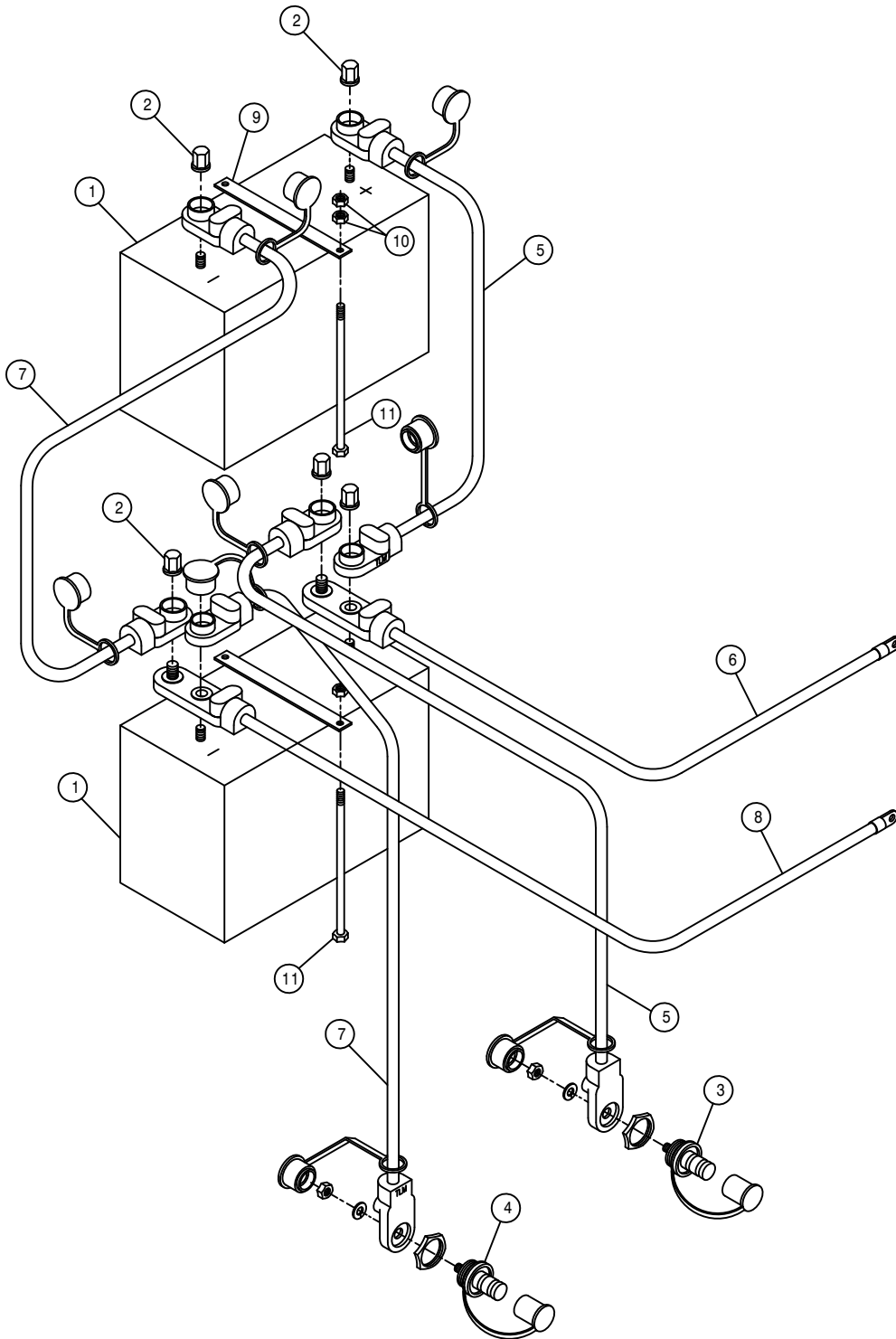

BATTERY ASSEMBLY

DET. QTY PART NO. DESCRIPTION

1	2	291196	BATTERY, 12V 950CCA, SS STUD
2	6	291205	BATTERY NUT, 3/8-16 SS CLSD CAP
3	1	291680	POSITIVE JUMPER STUD, RED
4	1	291681	NEGATIVE JUMPER STUD, BLACK
5	2	291705	BATT CABLE, RED 26" 2/0 3/8-3/8
6	1	291706	BATT CABLE, RED 70" 2/0 3/8-3/8
7	2	291707	BATT CABLE, BLK 26" 2/0 3/8-3/8
8	1	291708	BATT CABLE, BLK 73" 2/0 3/8-3/8
9	2	316470	BATTERY TIE-DOWN
10	8	910004	3/8UNC HEX NUT
11	4	900150	3/8UNC X 9 1/2 HEX BOLT

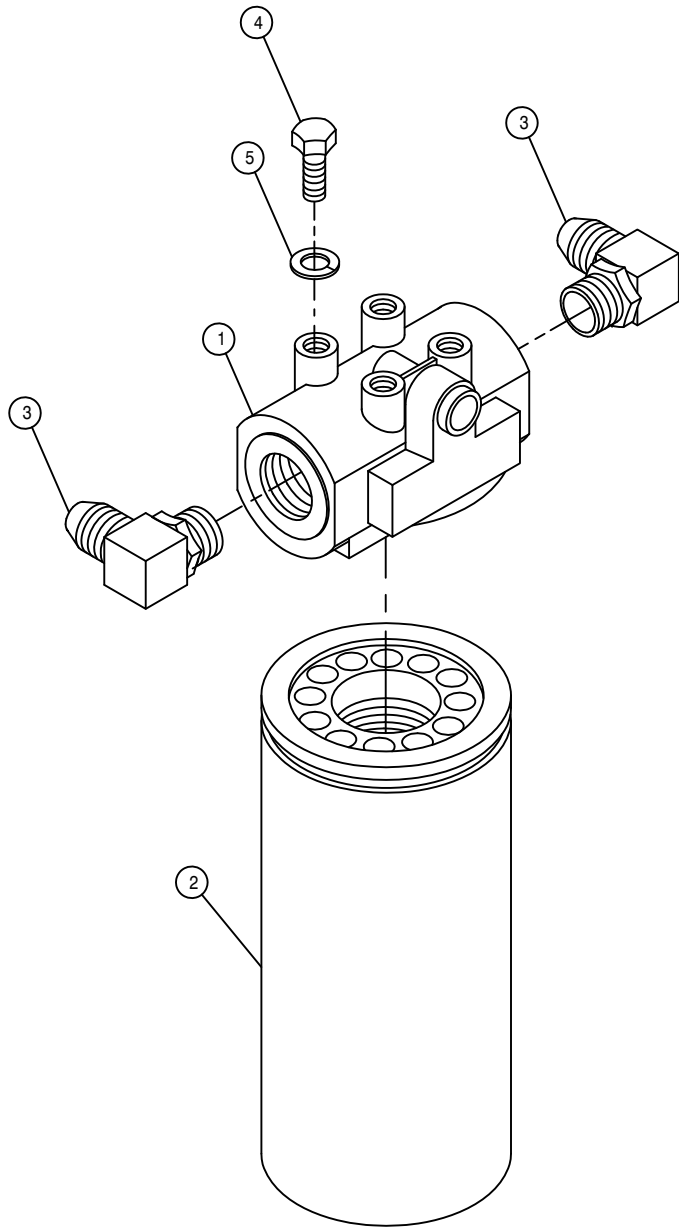

HI-PRESS FILTER ASSEMBLY

DET. QTY PART NO. DESCRIPTION

1	1	605608	HYD FILTER HEAD, DONALDSON
2	1	605609	HYD FILTER ELEMENT, DONALDSON
3	2	618474	3/4MJIC-90-1 1/16MOR LBO
4	4	900128	3/8UNC X 3/4 HEX BOLT
5	4	920502	3/8 LOCK WASHER

LADDER AND BRAKE VALVE ASSEMBLY

DET. QTY PART NO. DESCRIPTION

1	1	606011	LADDER/BRKWAY VLV W/TOWER ASSY
2	1	606013	BRAKE VLV W/TOWER ASSY
3	2	618126	9/16MJIC-9/16MOR ADPTR
4	4	618119	9/16MJIC-90-9/16MOR LBO
5	1	618486	9/16FJIC SW RUN TEE-9/16MJIC
6	1	618618	9/16MJIC-90-9/16FJIC SWIV LBO
7	1	618444	9/16MOR RUN TEE-9/16MJIC
8	2	900012	1/4UNC X 3 1/2 HEX BOLT
9	2	470121	1/4UNC HEX FLANGE LOCK NUT
10	1	342824	TRD ADJ HARNESS CONNECTOR BRKT
11	1	342826	SOLE VLV SPACER
12	2	914000	1/4UNC HEX STOVER NUT

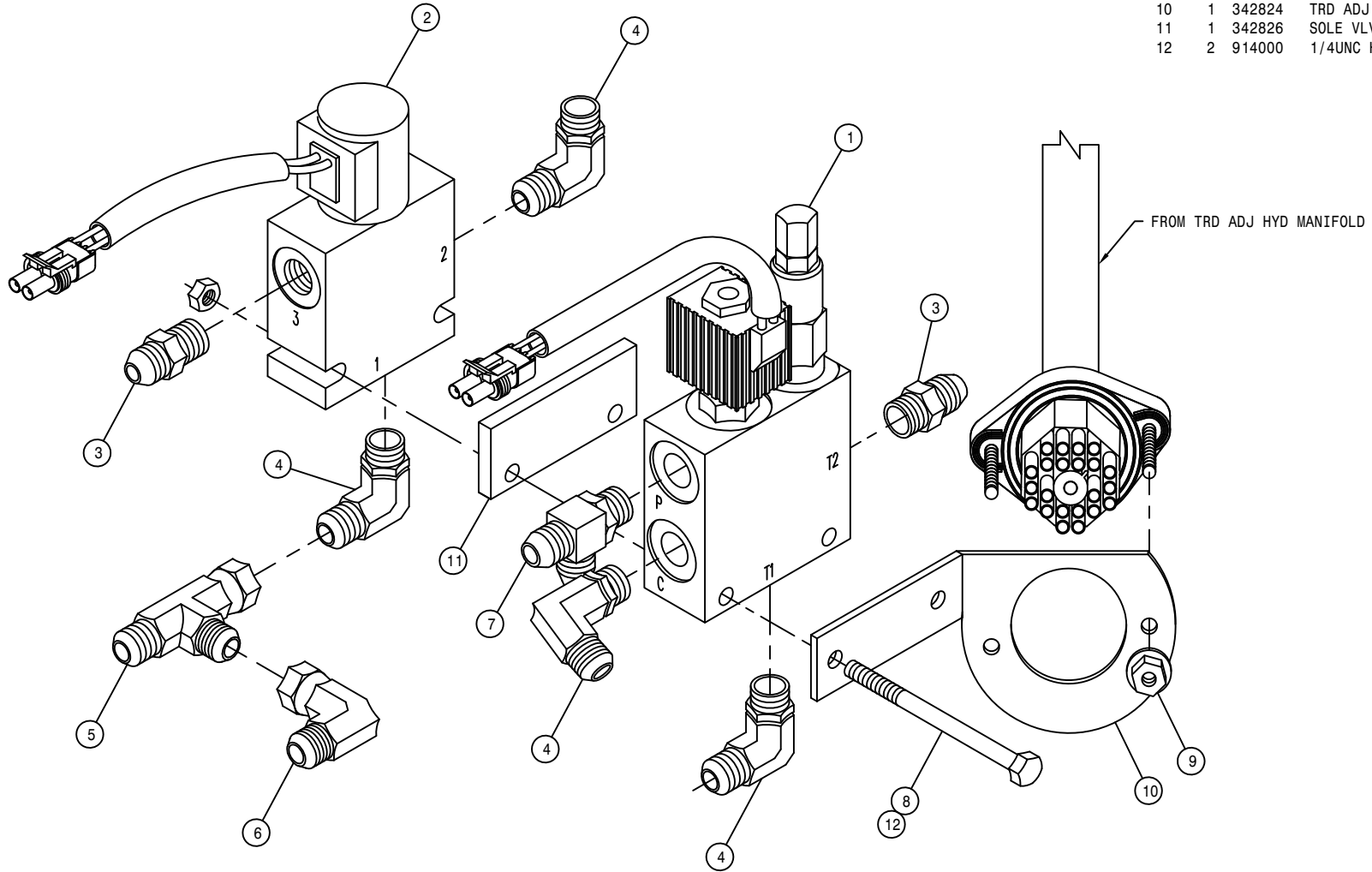

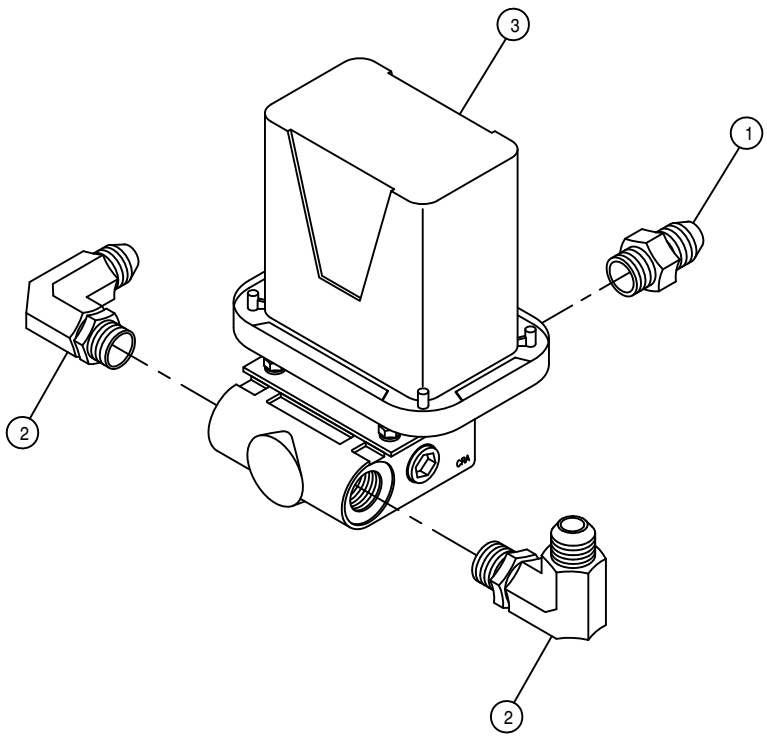

RAVEN HYD CONTROL VALVE ASSEMBLY

DET. QTY PART NO. DESCRIPTION

1	1	611127	1 1/16MJC-1 1/16MOR ADPTR
2	2	618248	1 1/16MJC-90-1 1/16MOR LBO
3	1	690666	VALVE HYD CTRL,30GPM RAVEN

RIGHT FRONT OUTER LEG ASSEMBLY

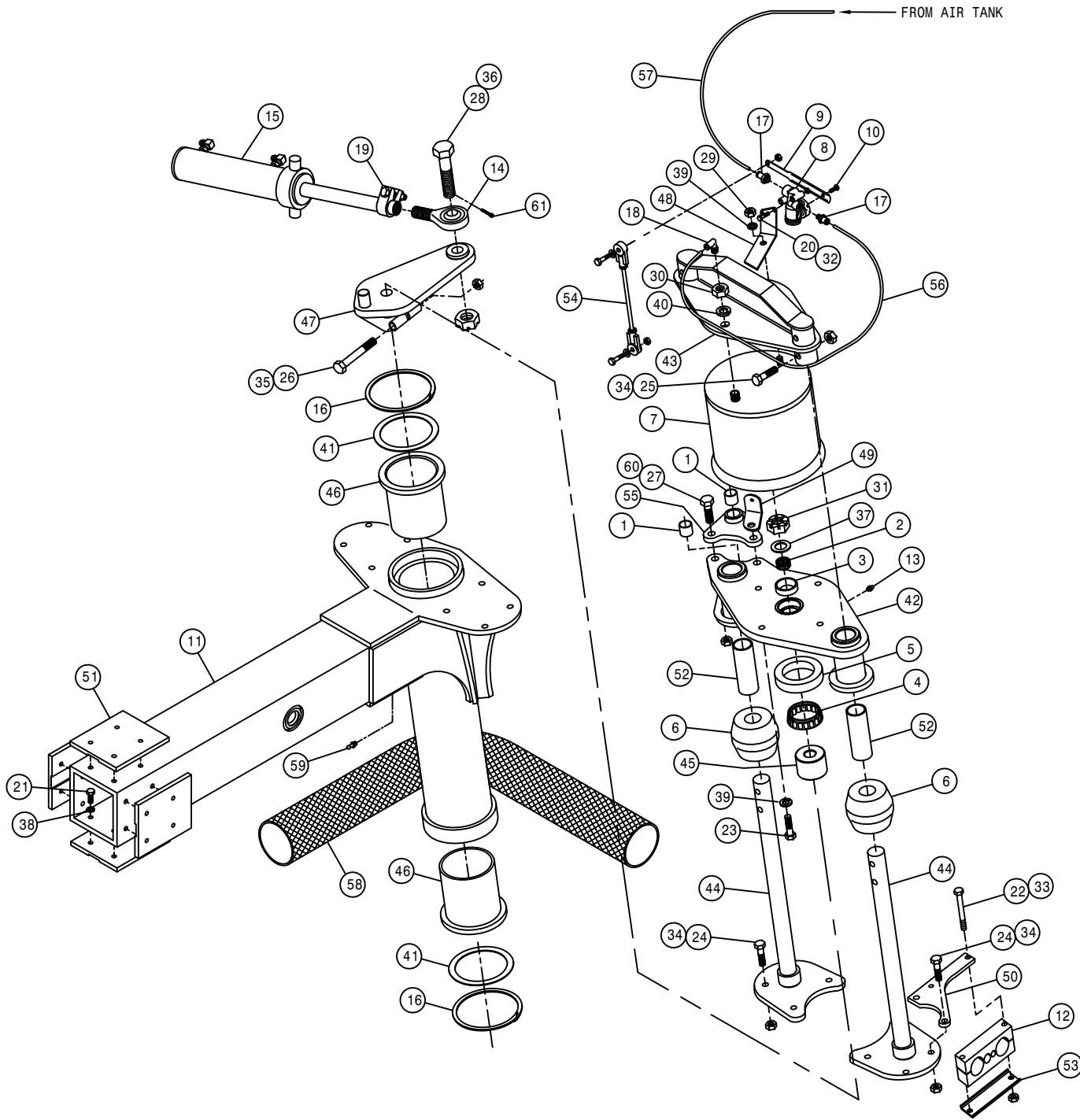

DET.	QTY	PART NO.	DESCRIPTION
	1	2	121029 JOURNAL BRG, 1.00 ID X 1.00 LG
	2	1	125050 BRG CONE, 1.00 ID W/FACE SEAL
	3	1	125051 BRG CUP FOR 125050
	4	1	125052 BRG CONE, 2.687 ID W/FACE SEAL
	5	1	125053 BRG CUP FOR 125052
	6	2	311058 RUBBER SPRING
	7	1	311066 AIRIDE SPRING, STS12
	8	1	311067 HEIGHT CONTROL AIR VALVE
	9	1	311069 7.00 LEVER, CTRL AIR VLV 311067
	10	1	311070 LEVER SCREW, CTRL AIR VLV311067
	11	1	359005 OUTER LEG WLD, 72" STS12
	12	1	470305 HOSE CLAMP, 4-HOLE
	13	1	471005 1/4 28 X 1/2 GREASE ZERK
	14	1	473975 ROD END, 1"-12 RH MALE
	15	1	621050 STEERING CYL ASSY STS12
	16	2	629536 RETAINING RING, 6.00 INT SPIRAL
	17	2	711036 1/8MNPT-1/4 NYL TUBE FTG
	18	1	711040 1/4MNPT-1/4 NYL TUBE LBO
	19	1	749322 STEERING TUBE CLAMP & BOLT ASSY
	20	2	900006 1/4UNC X 1 3/4 HEX BOLT
	21	16	900129 3/8UNC X 1" HEX BOLT
	22	2	900138 3/8UNC X 3 1/2 HEX BOLT
	23	4	900265 1/2UNC X 1 1/2 HEX BOLT
	24	8	900267 1/2UNC X 2" HEX BOLT
	25	4	900269 1/2UNC X 2 3/4 HEX BOLT
	26	1	900343 5/8UNC X 4 1/2 HEX BOLT
	27	2	900352P 5/8UNC X 2 1/4 HEX BOLT
	28	1	359085 STEERING ARM BOLT, 1"-8THD STS
	29	1	910008 1/2UNC HEX NUT
	30	1	910013 3/4UNF HEX NUT
	31	1	910021 1"-14 SLOT JAM NUT
	32	2	914000 1/4UNC HEX STOVER NUT
	33	2	914004 3/8UNC HEX STOVER NUT
	34	12	914008 1/2UNC HEX STOVER NUT
	35	1	914010 5/8UNC HEX STOVER NUT
	36	1	910020 1" UNC HEX SLOTTED NUT
	37	1	920008 1" SAE FLAT WASHER
	38	16	920502 3/8 LOCK WASHER
	39	5	920504 1/2 LOCK WASHER
	40	1	920506 3/4 LOCK WASHER
	41	2	359084 WASH, 14GA X 4.75ID X 5.875OD
	42	1	359057 RH AIR BAG LOWER PLT WLD
	43	1	359052 AIR BAG TOWER TOP MT WLD
	44	2	359077 TOWER SHAFT WLD
	45	1	359082 STEERING ARM BRG SPACER
	46	2	121100 LEG SLEEVE BEARING, ORKOT
	47	1	359070 RH STEERING ARM WLD
	48	1	359049 RH LEG AIR VALVE MT
	49	1	359051 LWR AIR VALVE ARM MT
	50	1	359081 UPPER LEG HOSE MT PLT
	51	4	342719 TRD ADJ BRONZE BEARING, TAPPED
	52	2	121105 LEG TOWER SLIDE BEARING, ORKOT
	53	1	359094 HYD TUBE CLAMP KEEPER, 5.75
	54	1	359095 LEG HEIGHT CTRL LINKAGE, STS12
	55	1	359068 UPPER TRUNION MT PLT WLD
	56	1	601473 HOSE, 1/4 X 22 AIR
	57	1	601480 HOSE, 1/4 X 230 AIR
	58	1	470310 SIDEWINDER SLEEVE, 13.50 X 45"
	59	1	471021 GREASE ZERK 1/8 NPT STRAIGHT
	60	2	914010P 5/8UNC HEX STOVER NUT
	61	1	470117 COTTER PIN 3/16 1 3/4 SQ CUT

RIGHT FRONT INNER LEG ASSEMBLY

DET. QTY PART NO. DESCRIPTION

1	1	359004	INNER LEG WLD, 72" STS12
2	1	470117	COTTER PIN 3/16 1 3/4 SQ CUT
3	1	470305	HOSE CLAMP, 4-HOLE
4	2	473838	20MM-1.5 X 40MM HEX BOLT 8.8
5	2	473839	20MM FLAT WASHER
6	17	473840	16MM-2.00 X 40MM HEX BOLT 8.8
7	17	473841	16MM LOCK WASHER
8	1	606978	SUND HYD MOTOR
9	1	610711	TORQ HUB, 22:1 CW12
10	2	618652	1" SPLIT FLANGE KIT
11	2	618676	O-RING FOR 1" SPL FLG 618652
12	10	824055	22MM-1.50 FLANGED WHEEL NUT
13	2	900138	3/8UNC X 3 1/2 HEX BOLT
14	4	900264	1/2UNC X 1 1/4 HEX BOLT
15	4	900265	1/2UNC X 1 1/2 HEX BOLT
16	2	914004	3/8UNC HEX STOVER NUT
17	8	914008	1/2UNC HEX STOVER NUT
18	1	359103	RH WHL MTR SHIELD, SS STS12
19	2	359102	WHL MTR SHIELD BRACE
20	1	359096	RH LWR LEG HYD HOSE MT WLD
21	1	359094	HYD TUBE CLAMP KEEPER, 5.75
22	1	470312	SIDEWINDER SLEEVE, 14.00 X 68"
23	1	606018	O-RING, WHL MTR 606978/606981
24	1	618327	3/4MJIC-7/8MOR ADPTR

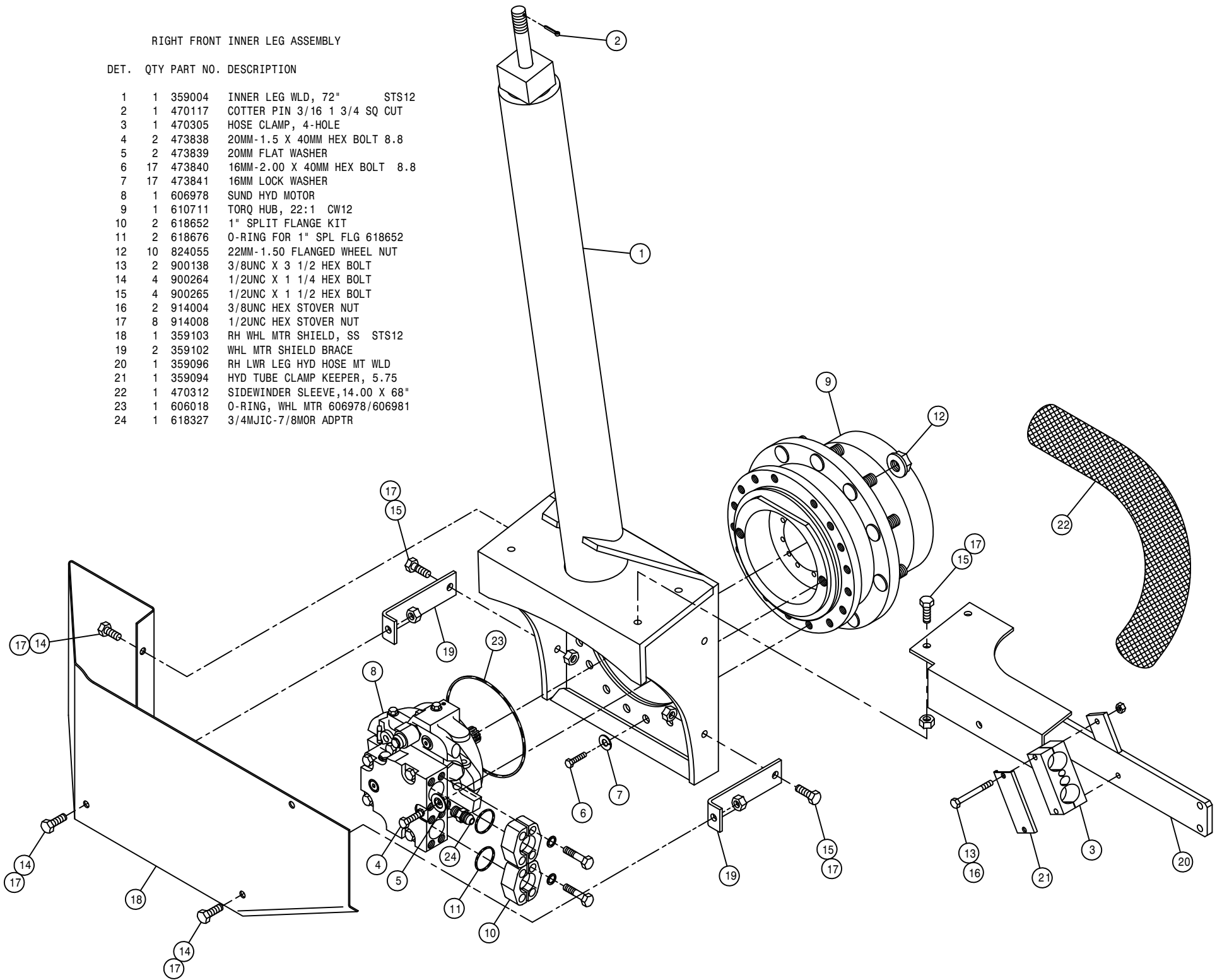

LEFT FRONT OUTER LEG ASSEMBLY

DET.	QTY	PART NO.	DESCRIPTION
1	2	121029	JOURNAL BRG, 1.00 ID X 1.00 LG
2	1	125050	BRG CONE, 1.00 ID W/FACE SEAL
3	1	125051	BRG CUP FOR 125050
4	1	125052	BRG CONE, 2.687 ID W/FACE SEAL
5	1	125053	BRG CUP FOR 125052
6	2	311058	RUBBER SPRING
7	1	311066	AIRIDE SPRING, STS12
8	1	311067	HEIGHT CONTROL AIR VALVE
9	1	311069	7.00 LEVER, CTRL AIR VLV 311067
10	1	311070	LEVER SCREW, CTRL AIR VLV311067
11	1	359005	OUTER LEG WLD, 72" STS12
12	1	470305	HOSE CLAMP, 4-HOLE
13	1	471005	1/4 28 X 1/2 GREASE ZERK
14	1	473975	ROD END, 1"-12 RH MALE
15	1	621050	STEERING CYL ASSY STS12
16	2	629536	RETAINING RING, 6.00 INT SPIRAL
17	2	711036	1/8MNPT-1/4 NYL TUBE FTG
18	1	711040	1/4MNPT-1/4 NYL TUBE LBO
19	1	749322	STEERING TUBE CLAMP & BOLT ASSY
20	2	900006	1/4UNC X 1 3/4 HEX BOLT
21	16	900129	3/8UNC X 1" HEX BOLT
22	2	900138	3/8UNC X 3 1/2 HEX BOLT
23	4	900265	1/2UNC X 1 1/2 HEX BOLT
24	8	900267	1/2UNC X 2" HEX BOLT
25	4	900269	1/2UNC X 2 3/4 HEX BOLT
26	1	900343	5/8UNC X 4 1/2 HEX BOLT
27	2	900352P	5/8UNC X 2 1/4 HEX BOLT
28	1	359085	STEERING ARM BOLT, 1"-8THD STS
29	1	910008	1/2UNC HEX NUT
30	1	910013	3/4UNF HEX NUT
31	1	910021	1" -14 SLOT JAM NUT
32	2	914000	1/4UNC HEX STOVER NUT
33	2	914004	3/8UNC HEX STOVER NUT
34	12	914008	1/2UNC HEX STOVER NUT
35	1	914010	5/8UNC HEX STOVER NUT
36	1	910020	1" UNC HEX SLOTTED NUT
37	1	920008	1" SAE FLAT WASHER
38	16	920502	3/8 LOCK WASHER
39	5	920504	1/2 LOCK WASHER
40	1	920506	3/4 LOCK WASHER
41	2	359084	WASH, 14GA X 4.75ID X 5.875OD
42	1	359058	LH AIR BAG LOWER PLT WLD
43	1	359052	AIR BAG TOWER TOP MT WLD
44	2	359077	TOWER SHAFT WLD
45	1	359082	STEERING ARM BRG SPACER
46	2	121100	LEG SLEEVE BEARING, ORKOT
47	1	359071	LH STEERING ARM WLD
48	1	359050	LH LEG AIR VALVE MT
49	1	359051	LWR AIR VALVE ARM MT
50	1	359081	UPPER LEG HOSE MT PLT
51	4	342719	TRD ADJ BRONZE BEARING, TAPPED
52	2	121105	LEG TOWER SLIDE BEARING, ORKOT
53	1	359094	HYD TUBE CLAMP KEEPER, 5.75
54	1	359095	LEG HEIGHT CTRL LINKAGE, STS12
55	1	359068	UPPER TRUNION MT PLT WLD
56	1	601473	HOSE, 1/4 X 22 AIR
57	1	601479	HOSE, 1/4 X 196 AIR
58	1	470310	SIDEWINDER SLEEVE, 13.50 X 45"
59	1	471021	GREASE ZERK 1/8 NPT STRAIGHT
60	2	914010P	5/8UNC HEX STOVER NUT
61	1	470117	COTTER PIN 3/16 1 3/4 SQ CUT

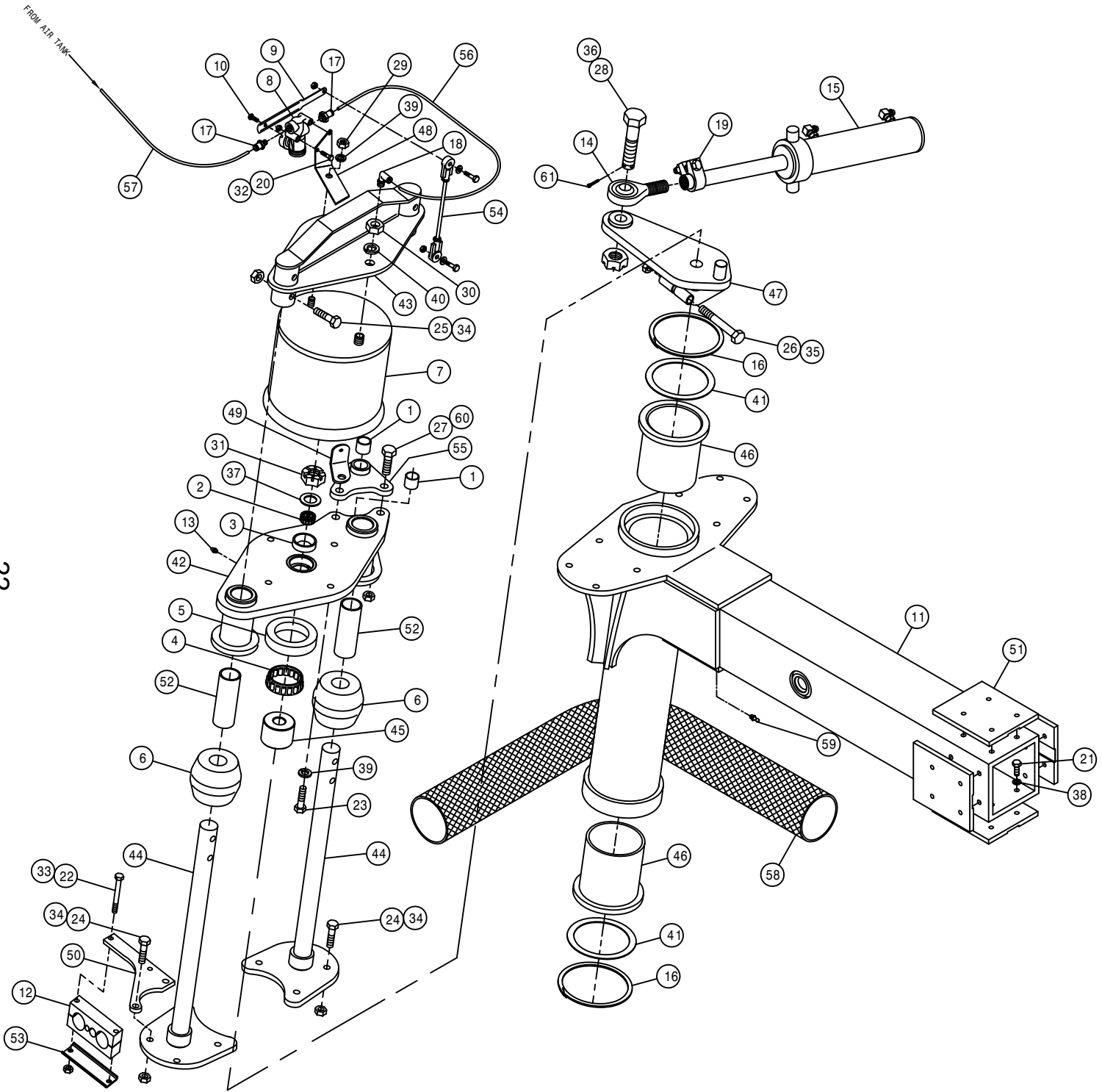

LEFT FRONT INNER LEG ASSEMBLY

DET. QTY PART NO. DESCRIPTION

DET.	QTY	PART NO.	DESCRIPTION
1	1	359004	INNER LEG WLD, 72" STS12
2	1	470117	COTTER PIN 3/16 1 3/4 SQ CUT
3	1	470305	HOSE CLAMP, 4-HOLE
4	2	473838	20MM-1.5 X 40MM HEX BOLT 8.8
5	2	473839	20MM FLAT WASHER
6	17	473840	16MM-2.00 X 40MM HEX BOLT 8.8
7	17	473841	16MM LOCK WASHER
8	1	606978	SUND HYD MOTOR
9	1	610711	TORQ HUB, 22:1 CW12
10	2	618652	1" SPLIT FLANGE KIT
11	2	618676	O-RING FOR 1" SPL FLG 618652
12	10	824055	22MM-1.50 FLANGED WHEEL NUT
13	2	900138	3/8UNC X 3 1/2 HEX BOLT
14	4	900264	1/2UNC X 1 1/4 HEX BOLT
15	4	900265	1/2UNC X 1 1/2 HEX BOLT
16	2	914004	3/8UNC HEX STOVER NUT
17	8	914008	1/2UNC HEX STOVER NUT
18	1	359104	LH WHL MTR SHIELD, SS STS12
19	2	359102	WHL MTR SHIELD BRACE
20	1	359097	LH LWR LEG HYD HOSE MT WLD
21	1	359094	HYD TUBE CLAMP KEEPER, 5.75
22	1	470312	SIDEWINDER SLEEVE, 14.00 X 68"
23	1	606018	O-RING, WHL MTR 606978/606981
24	1	618327	3/4MJIC-7/8MOR ADPTR

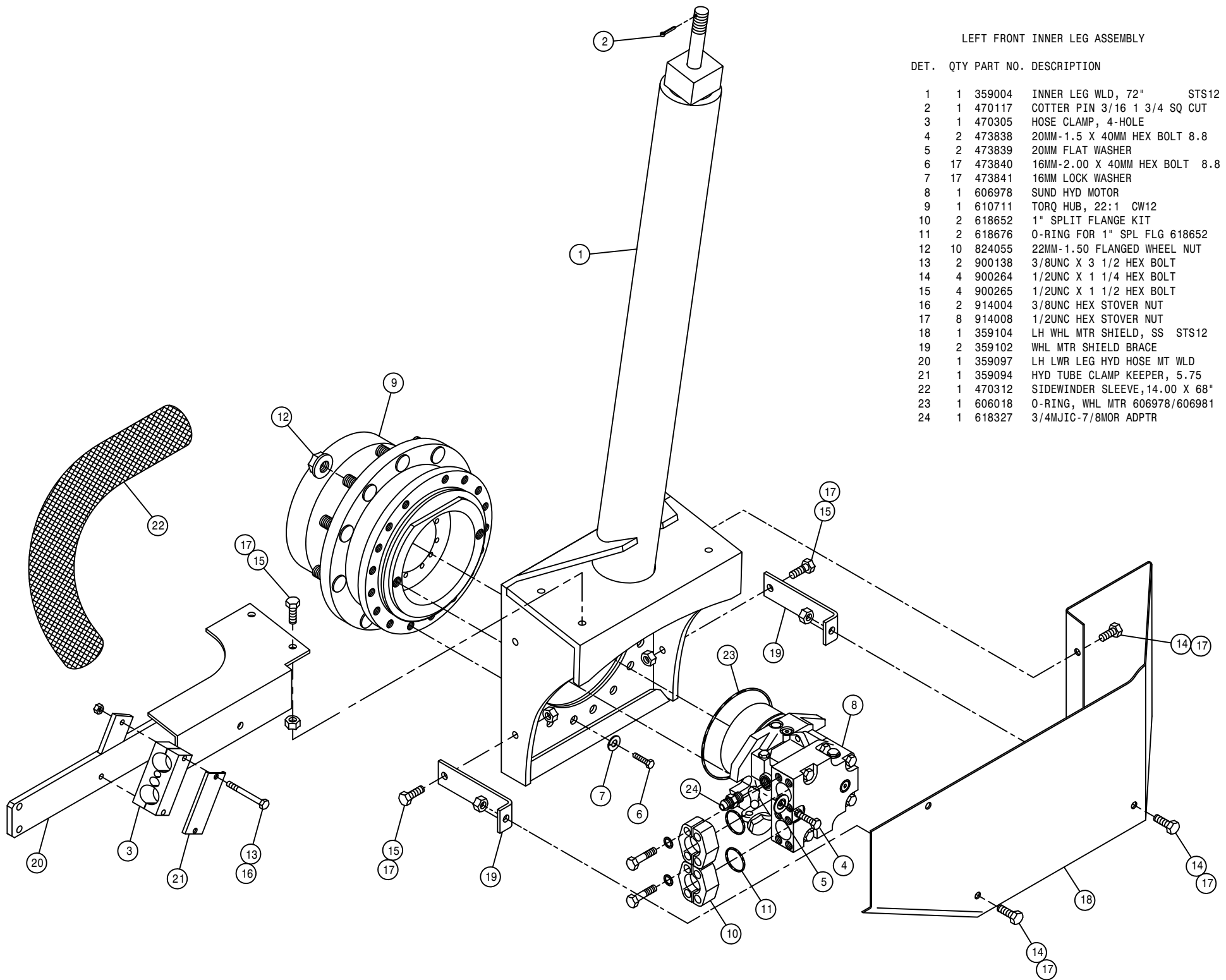

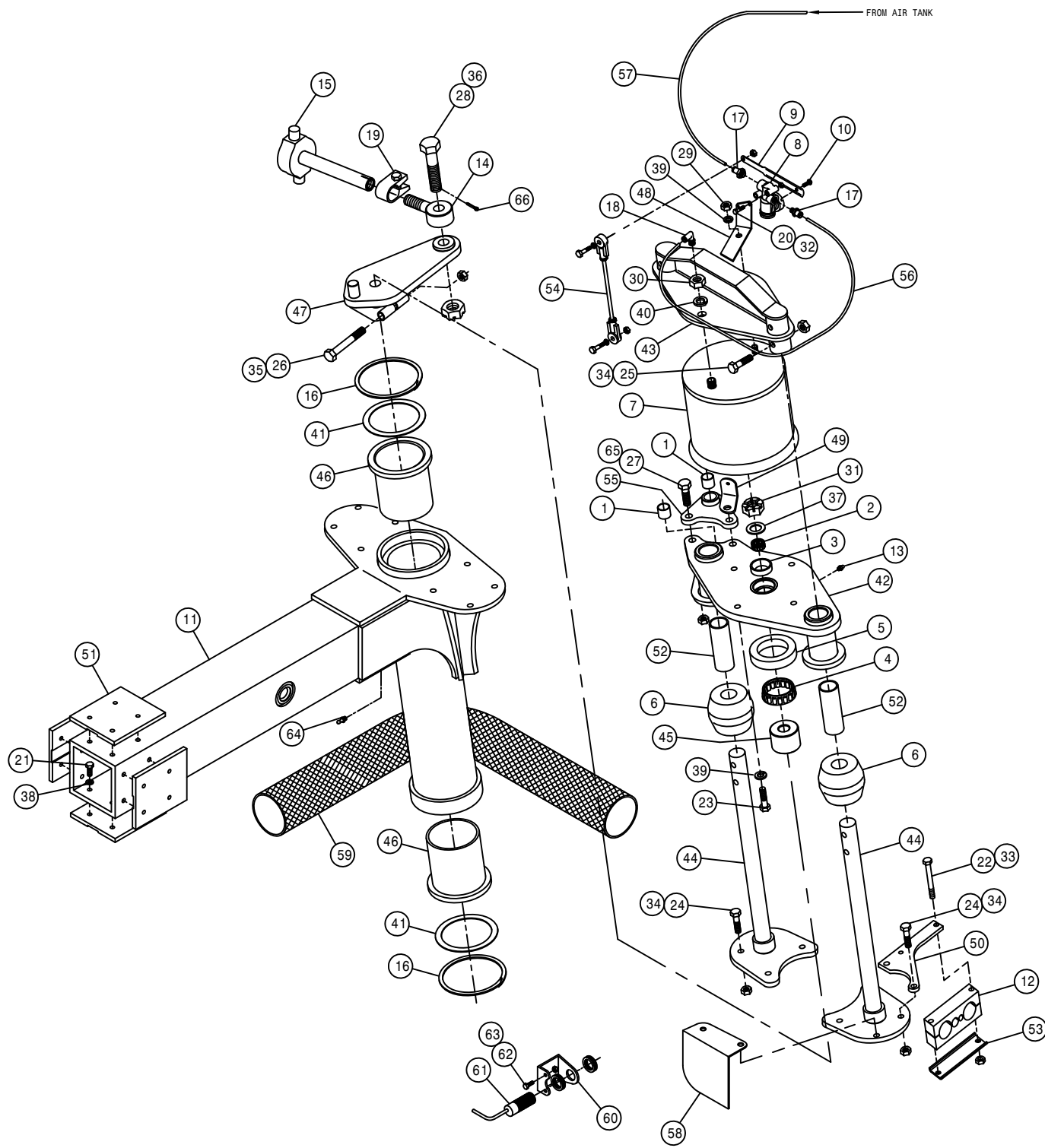

RIGHT REAR OUTER LEG ASSEMBLY

DET.	QTY	PART NO.	DESCRIPTION
1	2	121029	JOURNAL BRG, 1.00 ID X 1.00 LG
2	1	125050	BRG CONE, 1.00 ID W/FACE SEAL
3	1	125051	BRG CUP FOR 125050
4	1	125052	BRG CONE, 2.687 ID W/FACE SEAL
5	1	125053	BRG CUP FOR 125052
6	2	311058	RUBBER SPRING
7	1	311066	AIRIDE SPRING, STS12
8	1	311067	HEIGHT CONTROL AIR VALVE
9	1	311069	7.00 LEVER, CTRL AIR VLV 311067
10	1	311070	LEVER SCREW, CTRL AIR VLV311067
11	1	359005	OUTER LEG WLD, 72" STS12
12	1	470305	HOSE CLAMP, 4-HOLE
13	1	471005	1/4 28 X 1/2 GREASE ZERK
14	1	359089	TIE ROD STUD WLD
15	1	359086	REAR TIE ROD SHAFT WLD
16	2	629536	RETAINING RING, 6.00 INT SPIRAL
17	2	711036	1/8MNPT-1/4 NYL TUBE FTG
18	1	711040	1/4MNPT-1/4 NYL TUBE LBO
19	1	749322	STEERING TUBE CLAMP &BOLT ASSY
20	2	900006	1/4UNC X 1 3/4 HEX BOLT
21	16	900129	3/8UNC X 1" HEX BOLT
22	2	900138	3/8UNC X 3 1/2 HEX BOLT
23	4	900265	1/2UNC X 1 1/2 HEX BOLT
24	8	900267	1/2UNC X 2" HEX BOLT
25	4	900269	1/2UNC X 2 3/4 HEX BOLT
26	1	900343	5/8UNC X 4 1/2 HEX BOLT
27	2	900352P	5/8UNC X 2 1/4 HEX BOLT
28	1	359085	STEERING ARM BOLT, 1"-8THD STS
29	1	910008	1/2UNC HEX NUT
30	1	910013	3/4UNF HEX NUT
31	1	910021	1" - 14 SLOT JAM NUT
32	2	914000	1/4UNC HEX STOVER NUT
33	2	914004	3/8UNC HEX STOVER NUT
34	12	914008	1/2UNC HEX STOVER NUT
35	1	914010	5/8UNC HEX STOVER NUT
36	1	910020	1" UNC HEX SLOTTED NUT
37	1	920008	1" SAE FLAT WASHER
38	16	920502	3/8 LOCK WASHER
39	5	920504	1/2 LOCK WASHER
40	1	920506	3/4 LOCK WASHER
41	2	359084	WASH, 14GA X 4.75ID X 5.875OD
42	1	359057	RH AIR BAG LOWER PLT WLD
43	1	359052	AIR BAG TOWER TOP MT WLD
44	2	359077	TOWER SHAFT WLD
45	1	359082	STEERING ARM BRG SPACER
46	2	121100	LEG SLEEVE BEARING, ORKOT
47	1	359070	RH STEERING ARM WLD
48	1	359049	RH LEG AIR VALVE MT
49	1	359051	LWR AIR VALVE ARM MT
50	1	359081	UPPER LEG HOSE MT PLT
51	4	342719	TRD ADJ BRONZE BEARING, TAPPED
52	2	121105	LEG TOWER SLIDE BEARING, ORKOT
53	1	359094	HYD TUBE CLAMP KEEPER, 5.75
54	1	359095	LEG HEIGHT CTRL LINKAGE, STS12
55	1	359068	UPPER TRUNION MT PLT WLD
56	1	601473	HOSE, 1/4 X 22 AIR
57	1	601477	HOSE, 1/4 X 160 AIR
58	1	359092	RH SENSOR REFLECTOR
59	1	470311	SIDEWINDER SLEEVE, 14.00 X 60"
60	1	342856	TREAD SENSOR MT
61	1	293637	SENSOR W/SHROUD ASSY (SERV)
62	2	900064	5/16UNC X 3/4 HEX BOLT
63	2	914002	5/16UNC HEX STOVER NUT
64	1	471021	GREASE ZERK 1/8 NPT STRAIGHT
65	2	914010P	5/8UNC HEX STOVER NUT
66	1	470117	COTTER PIN 3/16 1 3/4 SQ CUT

RIGHT REAR INNER LEG ASSEMBLY

DET. QTY PART NO. DESCRIPTION

1	1	359004	INNER LEG WLD, 72"	STS12
2	1	470117	COTTER PIN 3/16 1 3/4 SQ CUT	
3	1	470305	HOSE CLAMP, 4-HOLE	
4	2	473838	20MM-1.5 X 40MM HEX BOLT 8.8	
5	2	473839	20MM FLAT WASHER	
6	17	473840	16MM-2.00 X 40MM HEX BOLT 8.8	
7	17	473841	16MM LOCK WASHER	
8	1	606978	SUND HYD MOTOR	
9	1	610714	TORQ HUB, 27:1 CW12	
10	1	618666	7/16MJIC-M12X1.5MOR ADPTR	
11	2	618652	1" SPLIT FLANGE KIT	
12	2	618676	O-RING FOR 1" SPL FLG 618652	
13	10	824055	22MM-1.50 FLANGED WHEEL NUT	
14	2	900138	3/8UNC X 3 1/2 HEX BOLT	
15	4	900264	1/2UNC X 1 1/4 HEX BOLT	
16	4	900265	1/2UNC X 1 1/2 HEX BOLT	
17	2	914004	3/8UNC HEX STOVER NUT	
18	8	914008	1/2UNC HEX STOVER NUT	
19	1	359103	RH WHL MTR SHIELD, SS STS12	
20	2	359102	WHL MTR SHIELD BRACE	
21	1	359096	RH LWR LEG HYD HOSE MT WLD	
22	1	359094	HYD TUBE CLAMP KEEPER, 5.75	
23	1	470312	SIDEWINDER SLEEVE, 14.00 X 68"	
24	1	606018	O-RING, WHL MTR 606978/606981	
25	1	618327	3/4MJIC-7/8MOR ADPTR	

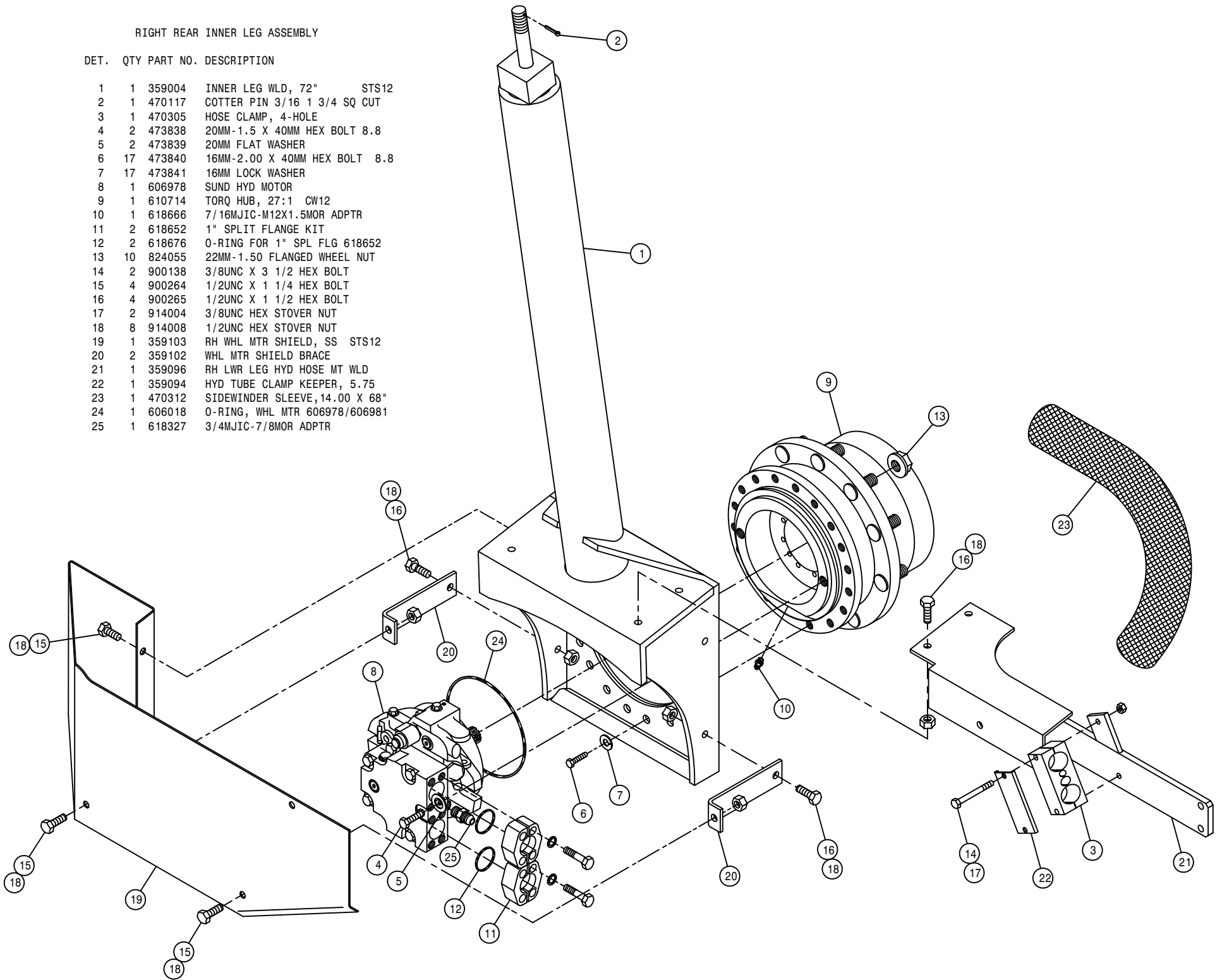

LEFT REAR OUTER LEG ASSEMBLY

DET.	QTY	PART NO.	DESCRIPTION
1	2	121029	JOURNAL BRG, 1.00 ID X 1.00 LG
2	1	125050	BRG CONE,1.00 ID W/FACE SEAL
3	1	125051	BRG CUP FOR 125050
4	1	125052	BRG CONE, 2.687 ID W/FACE SEAL
5	1	125053	BRG CUP FOR 125052
6	2	311058	RUBBER SPRING
7	1	311066	AIRIDE SPRING, STS12
8	1	311067	HEIGHT CONTROL AIR VALVE
9	1	311069	7.00 LEVER,CTRL AIR VLV 311067
10	1	311070	LEVER SCREW,CTRL AIR VLV311067
11	1	359005	OUTER LEG WLD, 72" STS12
12	1	470305	HOSE CLAMP, 4-HOLE
13	1	471005	1/4 28 X 1/2 GREASE ZERK
14	1	359089	TIE ROD STUD WLD
15	1	359086	REAR TIE ROD SHAFT WLD
16	2	629536	RETAINING RING,6.00 INT SPIRAL
17	2	711036	1/8MNPT-1/4 NYL TUBE FTG
18	1	711040	1/4MNPT-1/4 NYL TUBE LBO
19	1	749322	STEERING TUBE CLAMP & BOLT ASSY
20	2	900006	1/4UNC X 1 3/4 HEX BOLT
21	16	900129	3/8UNC X 1" HEX BOLT
22	2	900138	3/8UNC X 3 1/2 HEX BOLT
23	4	900265	1/2UNC X 1 1/2 HEX BOLT
24	8	900267	1/2UNC X 2" HEX BOLT
25	4	900269	1/2UNC X 2 3/4 HEX BOLT
26	1	900343	5/8UNC X 4 1/2 HEX BOLT
27	2	900352P	5/8UNC X 2 1/4 HEX BOLT
28	1	359085	STEERING ARM BOLT, 1"-8THD STS
29	1	910008	1/2UNC HEX NUT
30	1	910013	3/4UNF HEX NUT
31	1	910021	1"-14 SLOT JAM NUT
32	2	914000	1/4UNC HEX STOVER NUT
33	2	914004	3/8UNC HEX STOVER NUT
34	12	914008	1/2UNC HEX STOVER NUT
35	1	914010	5/8UNC HEX STOVER NUT
36	1	910020	1" UNC HEX SLOTTED NUT
37	1	920008	1" SAE FLAT WASHER
38	16	920502	3/8 LOCK WASHER
39	5	920504	1/2 LOCK WASHER
40	1	920506	3/4 LOCK WASHER
41	2	359084	WASH,14GA X 4.75ID X 5.875OD
42	1	359058	LH AIR BAG LOWER PLT WLD
43	1	359052	AIR BAG TOWER TOP MT WLD
44	2	359077	TOWER SHAFT WLD
45	1	359082	STEERING ARM BRG SPACER
46	2	121100	LEG SLEEVE BEARING, ORKOT
47	1	359071	LH STEERING ARM WLD
48	1	359050	LH LEG AIR VALVE MT
49	1	359051	LWR AIR VALVE ARM MT
50	1	359081	UPPER LEG HOSE MT PLT
51	4	342719	TRD ADJ BRONZE BEARING, TAPPED
52	2	121105	LEG TOWER SLIDE BEARING, ORKOT
53	1	359094	HYD TUBE CLAMP KEEPER, 5.75
54	1	359095	LEG HEIGHT CTRL LINKAGE, STS12
55	1	359068	UPPER TRUNION MT PLT WLD
56	1	601473	HOSE, 1/4 X 22 AIR
57	1	601476	HOSE, 1/4 X 120 AIR
58	1	359093	LH SENSOR REFLECTOR
59	1	470311	SIDEWINDER SLEEVE,14.00 X 60"
60	1	342856	TREAD SENSOR MT
61	1	293637	SENSOR W/SHROUD ASSY (SERV)
62	2	900064	5/16UNC X 3/4 HEX BOLT
63	2	914002	5/16UNC HEX STOVER NUT
64	1	471021	GREASE ZERK 1/8 NPT STRAIGHT
65	2	914010P	5/8UNC HEX STOVER NUT
66	1	470117	COTTER PIN 3/16 1 3/4 SQ CUT

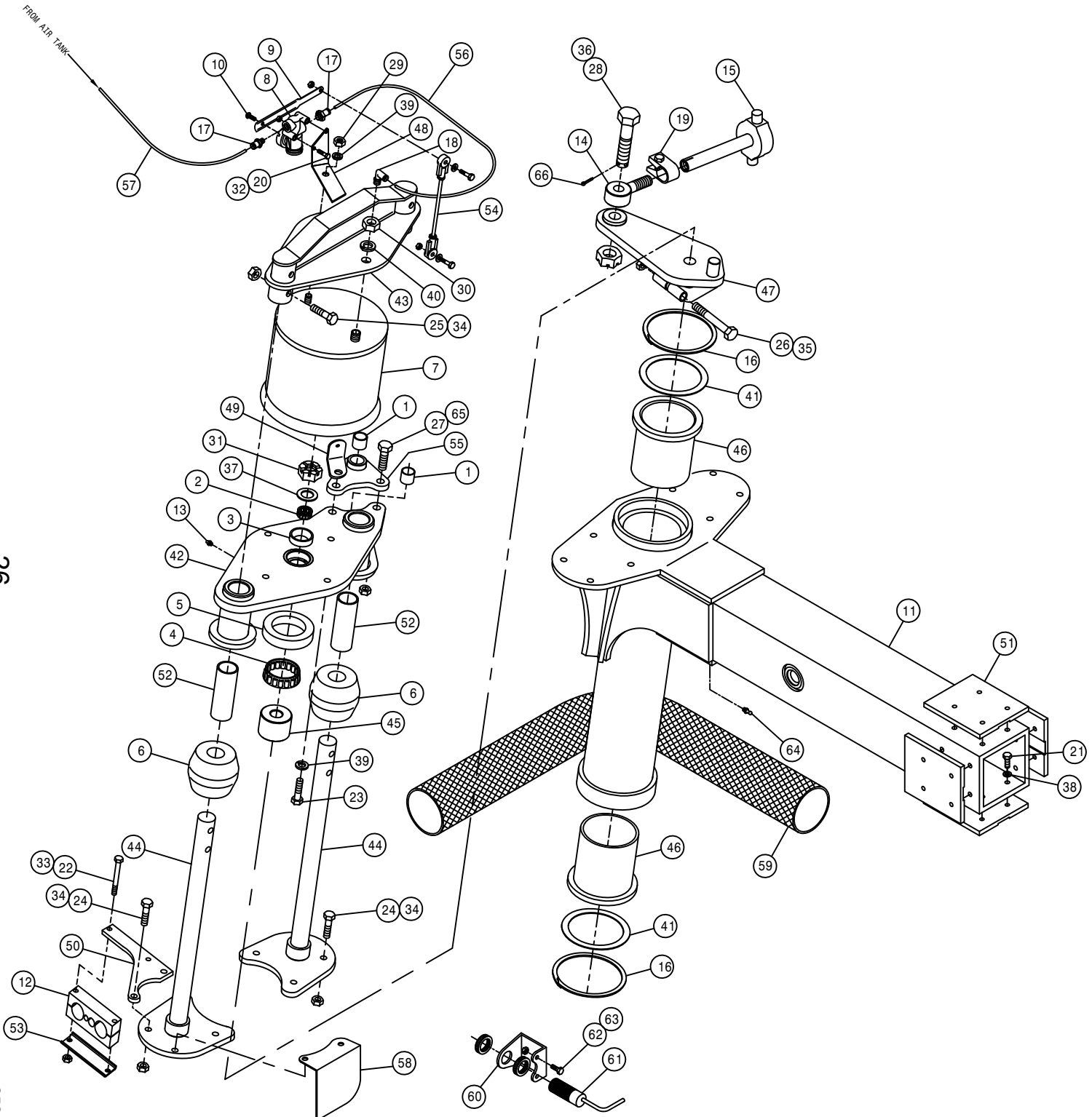

26

252026

LEFT REAR INNER LEG ASSEMBLY

DET. QTY PART NO. DESCRIPTION

DET.	QTY	PART NO.	DESCRIPTION
1	1	359004	INNER LEG WLD, 72" STS12
2	1	470117	COTTER PIN 3/16 1 3/4 SQ CUT
3	1	470305	HOSE CLAMP, 4-HOLE
4	2	473838	20MM-1.5 X 40MM HEX BOLT 8.8
5	2	473839	20MM FLAT WASHER
6	17	473840	16MM-2.00 X 40MM HEX BOLT 8.8
7	17	473841	16MM LOCK WASHER
8	1	606981	SUND HYD MOTOR W/SENSOR
9	1	610714	TORQ HUB, 27:1 CW12
10	1	618666	7/16MJIC-M12X1.5MOR ADPTR
11	2	618652	1" SPLIT FLANGE KIT
12	2	618676	O-RING FOR 1" SPL FLG 618652
13	10	824055	22MM-1.50 FLANGED WHEEL NUT
14	2	900138	3/8UNC X 3 1/2 HEX BOLT
15	4	900264	1/2UNC X 1 1/4 HEX BOLT
16	4	900265	1/2UNC X 1 1/2 HEX BOLT
17	2	914004	3/8UNC HEX STOVER NUT
18	8	914008	1/2UNC HEX STOVER NUT
19	1	359104	LH WHL MTR SHIELD, SS STS12
20	2	359102	WHL MTR SHIELD BRACE
21	1	359097	LH LWR LEG HYD HOSE MT WLD
22	1	359094	HYD TUBE CLAMP KEEPER, 5.75
23	1	606996	SPEED SENSOR,SUND MOTOR 606981
24	1	470312	SIDEWINDER SLEEVE,14.00 X 68"
25	1	606018	O-RING, WHL MTR 606978/606981
26	1	618327	3/4MJIC-7/8MOR ADPTR

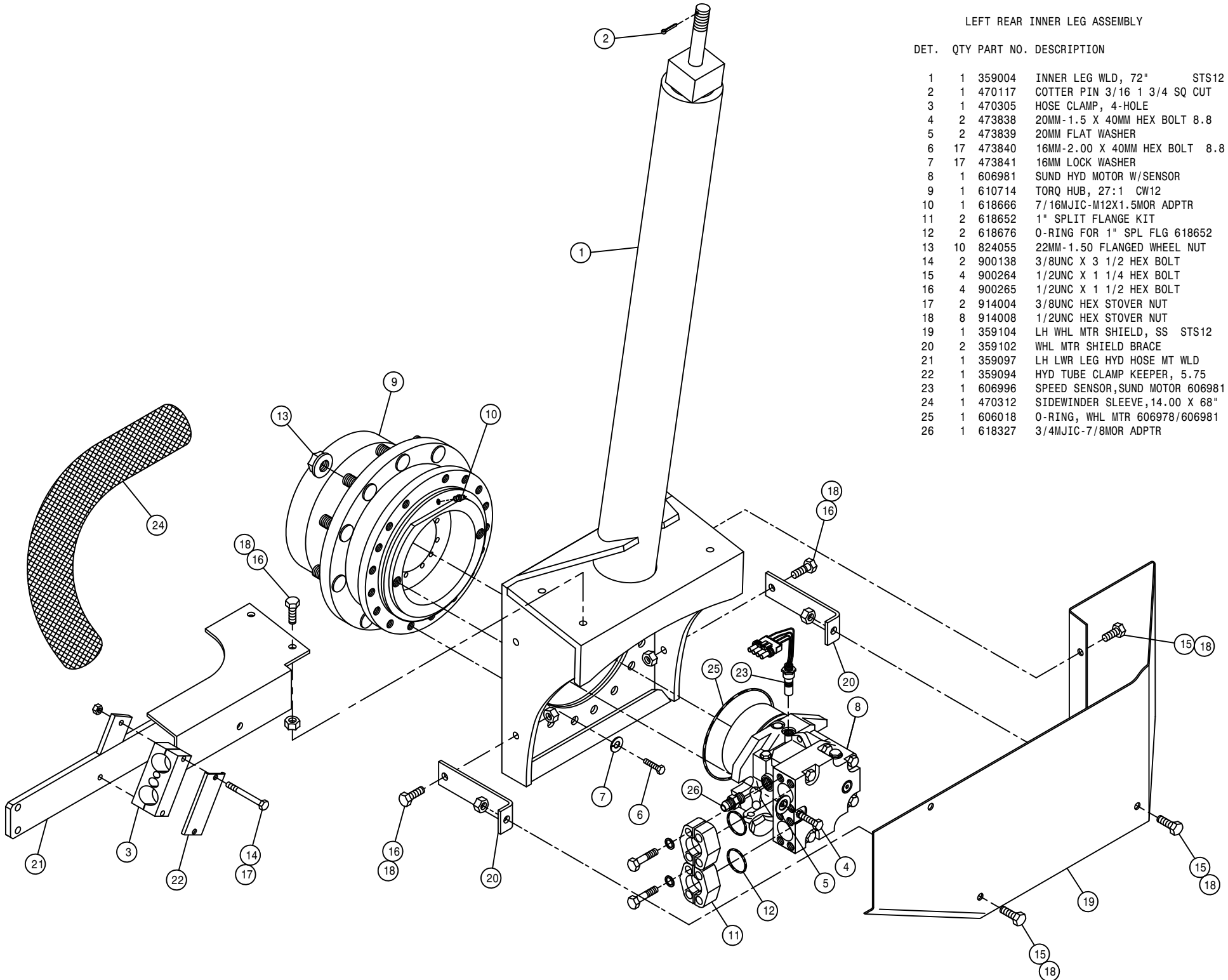

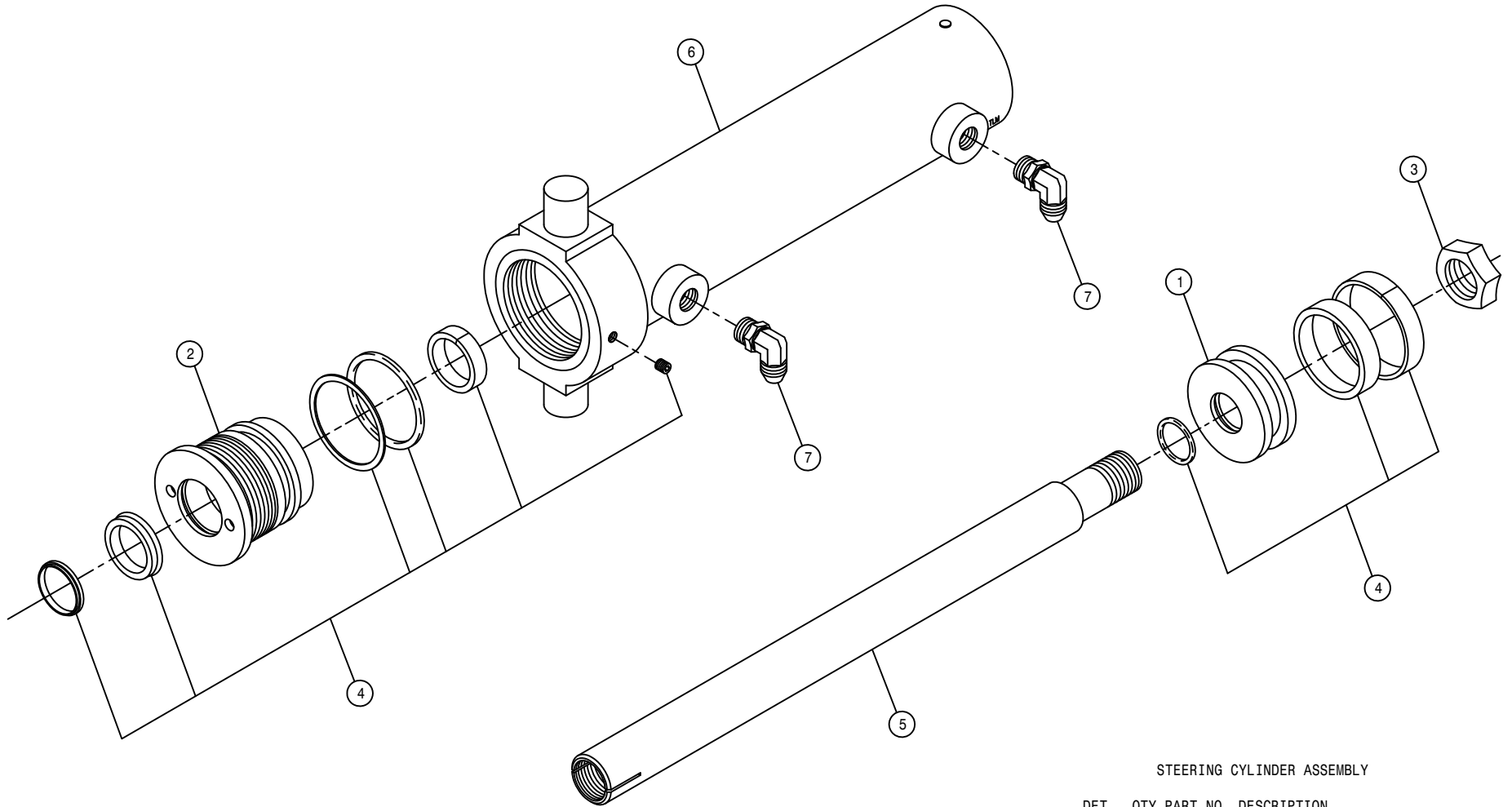

STEERING CYLINDER ASSEMBLY

DET.	QTY	PART NO.	DESCRIPTION
	1	620733	PISTON, P-2.50-109
	1	620748	HEAD, H-2.50-350
	1	620765	NUT, N-1.00-01
	1	620788	REPAIR KIT, HYD CYL, RK-2.50-803
	1	620913	SHAFT WLD, STRG CYL 620910
	1	620914	BARREL WLD, STRG CYL 620910
	2	618249	3/4MJIC-90-9/16MOR LBO

NOTE: 1. 620910 - STEERING CYLINDER ASSEMBLY ITEMS 1-6
 2. 621050 - STEERING CYLINDER ASSEMBLY WITH FITTINGS

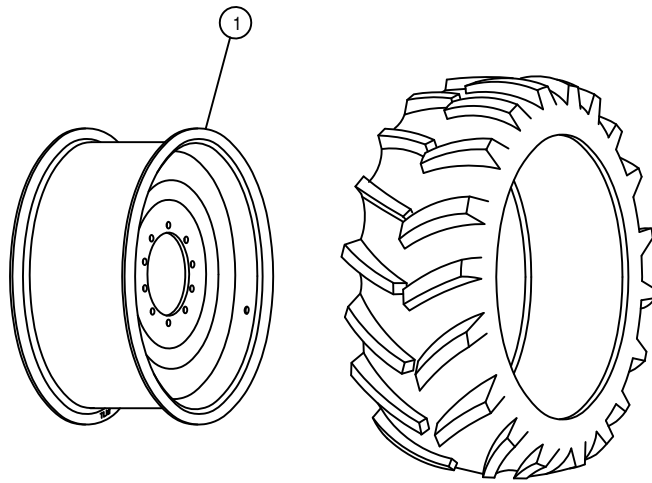

580/70 R38 RADIAL TIRE

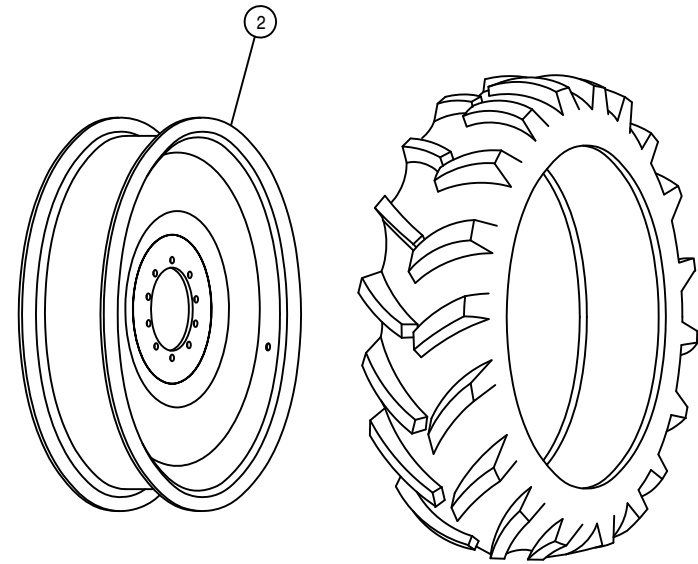

380/90 R46 RADIAL TIRE

OR
380/85 R46 RADIAL TIRE

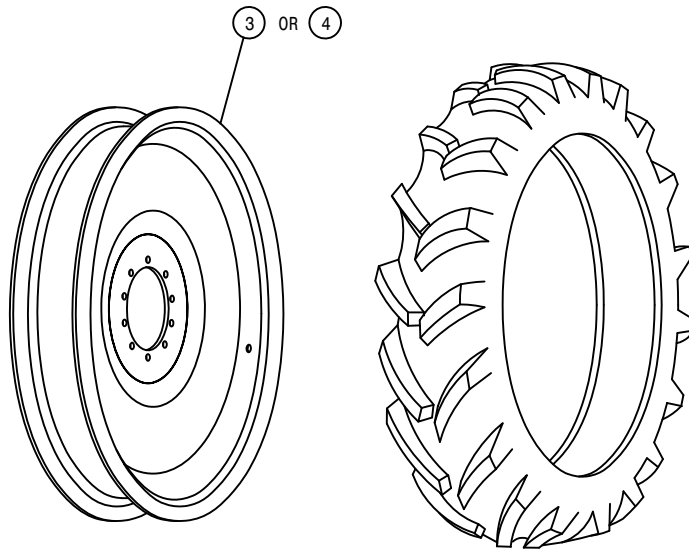

320/90 R50 RADIAL TIRE

TIRE AND RIM ASSEMBLY

DET.	QTY	PART NO.	DESCRIPTION	
1	1	821055	RIM WLD, 38 X W18A	STS12
2	1	821054	RIM WLD, 46 X W13A	STS12
3	1	821053	RIM WLD, 50 X DW10	STS12
4	1	821056	RIM WLD, 50 X 10 TITAN	

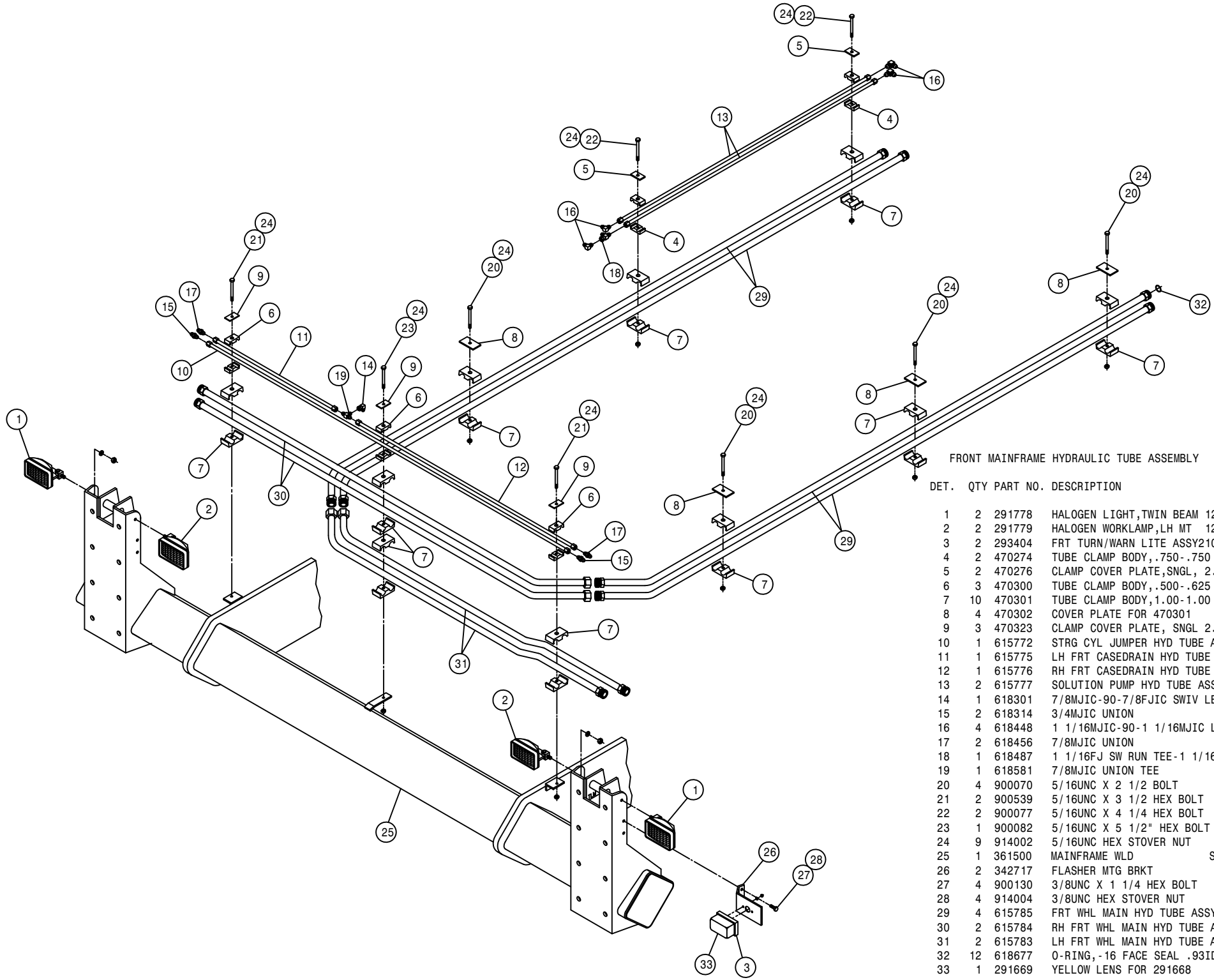

FRONT MAINFRAME HYDRAULIC TUBE ASSEMBLY

DET.	QTY	PART NO.	DESCRIPTION
1	2	291778	HALOGEN LIGHT, TWIN BEAM 12V55W
2	2	291779	HALOGEN WORKLAMP, LH MT 12V55W
3	2	293404	FRT TURN/WARN LITE ASSY 2100 98
4	2	470274	TUBE CLAMP BODY, .750-.750
5	2	470276	CLAMP COVER PLATE, SNGL, 2.55LG
6	3	470300	TUBE CLAMP BODY, .500-.625
7	10	470301	TUBE CLAMP BODY, 1.00-1.00
8	4	470302	COVER PLATE FOR 470301
9	3	470323	CLAMP COVER PLATE, SNGL 2.04LG
10	1	615772	STRG CYL JUMPER HYD TUBE ASSY
11	1	615775	LH FRT CASEDRAIN HYD TUBE ASSY
12	1	615776	RH FRT CASEDRAIN HYD TUBE ASSY
13	2	615777	SOLUTION PUMP HYD TUBE ASSY
14	1	618301	7/8MJIC-90-7/8FJIC SWIV LBO
15	2	618314	3/4MJIC UNION
16	4	618448	1 1/16MJIC-90-1 1/16MJIC LBO
17	2	618456	7/8MJIC UNION
18	1	618487	1 1/16FJ SW RUN TEE-1 1/16MJ
19	1	618581	7/8MJIC UNION TEE
20	4	900070	5/16UNC X 2 1/2 BOLT
21	2	900539	5/16UNC X 3 1/2 HEX BOLT
22	2	900077	5/16UNC X 4 1/4 HEX BOLT
23	1	900082	5/16UNC X 5 1/2" HEX BOLT
24	9	914002	5/16UNC HEX STOVER NUT
25	1	361500	MAINFRAME WLD STS12
26	2	342717	FLASHER MTG BRKT
27	4	900130	3/8UNC X 1 1/4 HEX BOLT
28	4	914004	3/8UNC HEX STOVER NUT
29	4	615785	FRT WHL MAIN HYD TUBE ASSY
30	2	615784	RH FRT WHL MAIN HYD TUBE ASSY
31	2	615783	LH FRT WHL MAIN HYD TUBE ASSY
32	12	618677	O-RING, -16 FACE SEAL .93ID 90D
33	1	291669	YELLOW LENS FOR 291668

30

252030

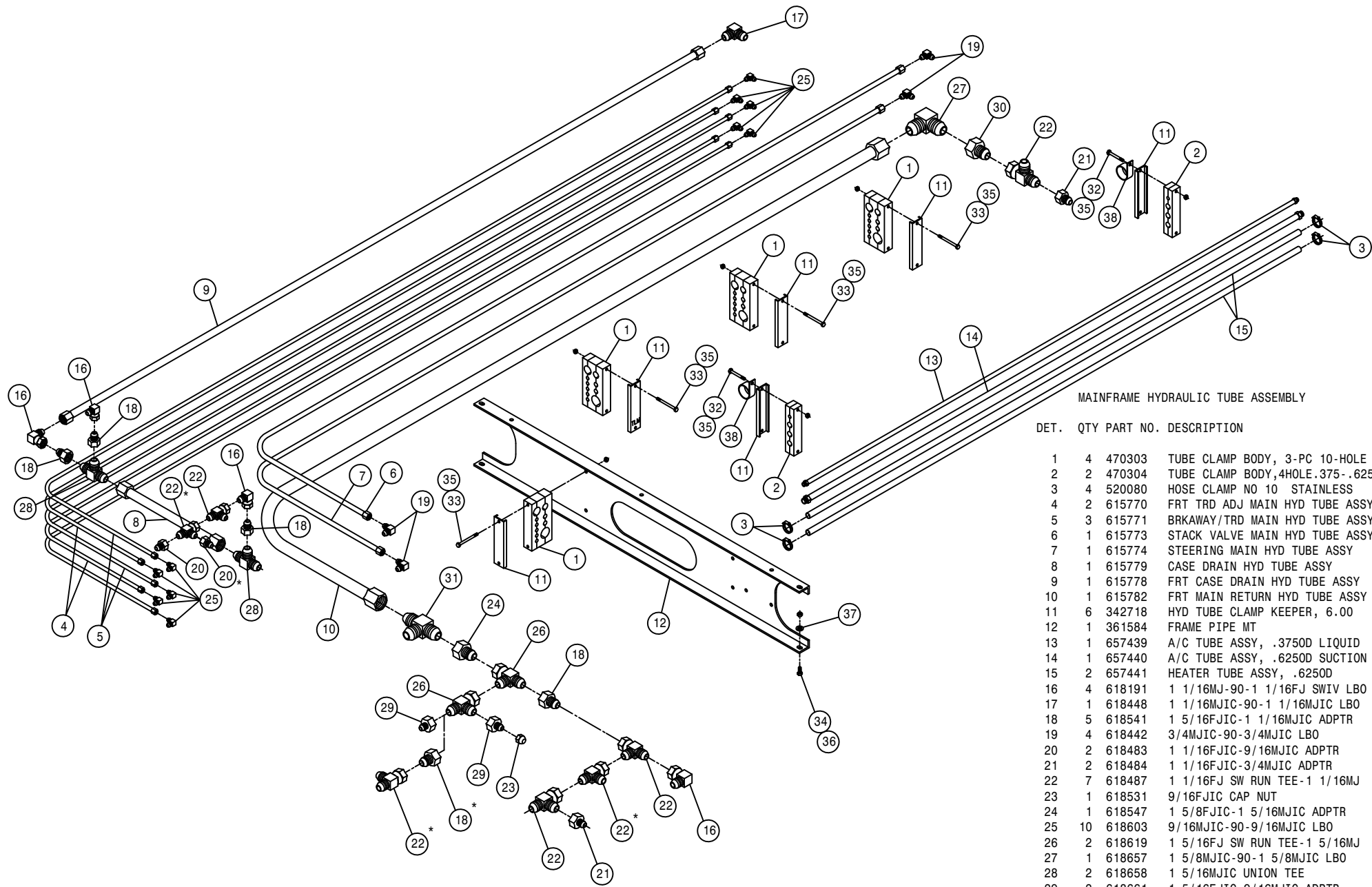

MAINFRAME HYDRAULIC TUBE ASSEMBLY

DET.	QTY	PART NO.	DESCRIPTION
	1	470303	TUBE CLAMP BODY, 3-PC 10-HOLE
	2	470304	TUBE CLAMP BODY, 4HOLE .375-.625
	3	520080	HOSE CLAMP NO 10 STAINLESS
	4	615770	FRT TRD ADJ MAIN HYD TUBE ASSY
	5	615771	BRKAWAY/TRD MAIN HYD TUBE ASSY
	6	615773	STACK VALVE MAIN HYD TUBE ASSY
	7	615774	STEERING MAIN HYD TUBE ASSY
	8	615779	CASE DRAIN HYD TUBE ASSY
	9	615778	FRT CASE DRAIN HYD TUBE ASSY
	10	615782	FRT MAIN RETURN HYD TUBE ASSY
	11	342718	HYD TUBE CLAMP KEEPER, 6.00
	12	361584	FRAME PIPE MT
	13	657439	A/C TUBE ASSY, .3750D LIQUID
	14	657440	A/C TUBE ASSY, .6250D SUCTION
	15	657441	HEATER TUBE ASSY, .6250D
	16	618191	1 1/16MJ-90-1 1/16FJ SWIV LBO
	17	618448	1 1/16MJIC-90-1 1/16MJIC LBO
	18	618541	1 5/16FJIC-1 1/16MJIC ADPTR
	19	618442	3/4MJIC-90-3/4MJIC LBO
	20	618483	1 1/16FJIC-9/16MJIC ADPTR
	21	618484	1 1/16FJIC-3/4MJIC ADPTR
	22	618487	1 1/16FJ SW RUN TEE-1 1/16MJ
	23	618531	9/16FJIC CAP NUT
	24	618547	1 5/8FJIC-1 5/16MJIC ADPTR
	25	618603	9/16MJIC-90-9/16MJIC LBO
	26	618619	1 5/16FJ SW RUN TEE-1 5/16MJ
	27	618657	1 5/8MJIC-90-1 5/8MJIC LBO
	28	618658	1 5/16MJIC UNION TEE
	29	618661	1 5/16FJIC-9/16MJIC ADPTR
	30	618665	1 5/8FJIC-1 1/16MJIC ADPTR
	31	618659	1 5/8MJIC UNION TEE
	32	900007	1/4UNC X 2" HEX BOLT
	33	900014	1/4UNC X 4" HEX BOLT
	34	900129	3/8UNC X 1" HEX BOLT
	35	914000	1/4UNC HEX STOVER NUT
	36	914004	3/8UNC HEX STOVER NUT
	37	920002	3/8 SAE FLAT WASHER
	38	520126	CUSH HOSE CLAMP 2IN X 5/8W

NOTE: ITEMS MARKED WITH A (*) ARE USED WITH THE SIDE FILL OPTION AND PRESSURE WASHER OPTION.

TREAD ADJUST ASSEMBLY

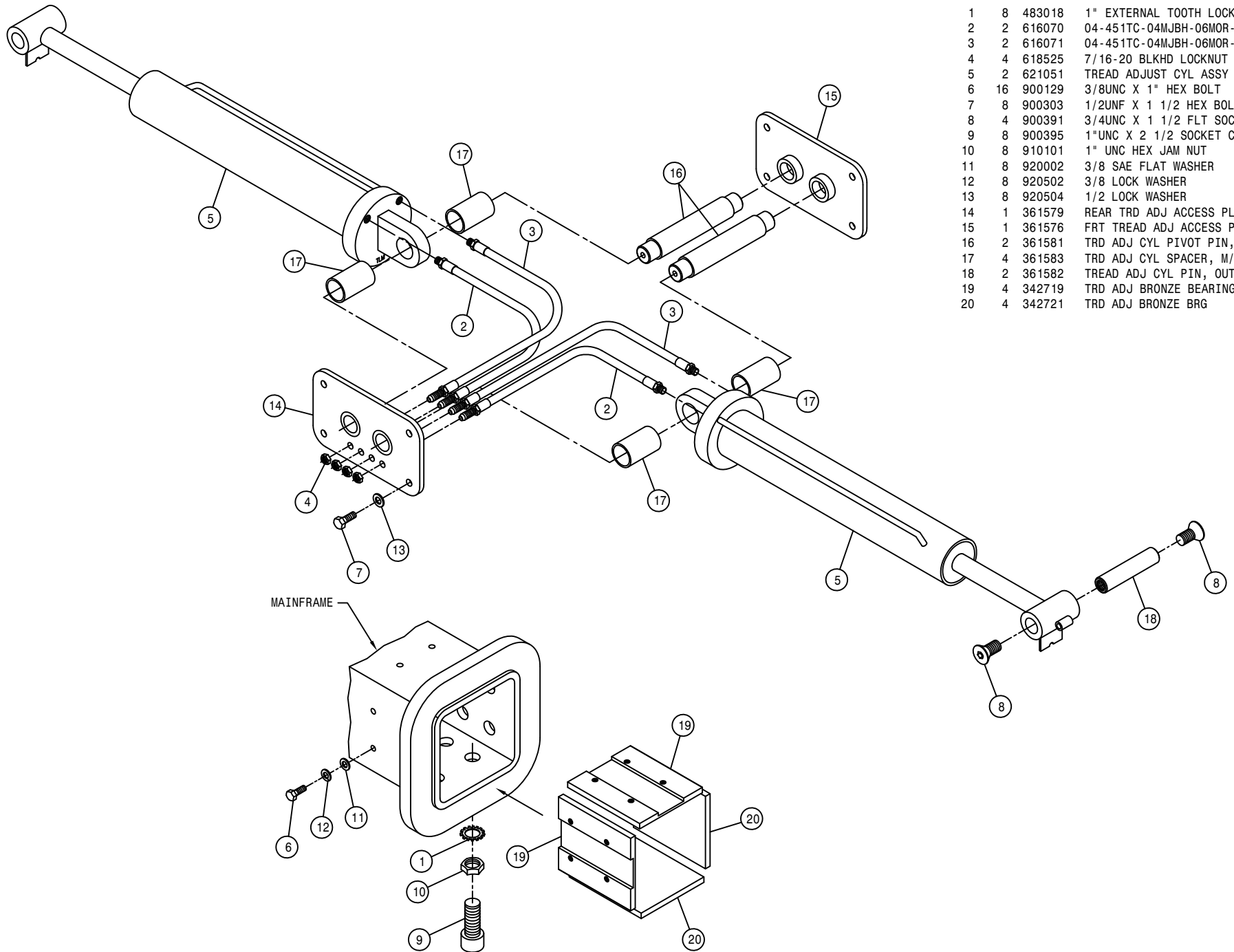

DET.	QTY	PART NO.	DESCRIPTION
1	8	483018	1" EXTERNAL TOOTH LOCK WASHER
2	2	616070	04-451TC-04MJBH-06MOR-11.00H/A
3	2	616071	04-451TC-04MJBH-06MOR-13.00H/A
4	4	618525	7/16-20 BLKHD LOCKNUT
5	2	621051	TREAD ADJUST CYL ASSY STS12
6	16	900129	3/8UNC X 1" HEX BOLT
7	8	900303	1/2UNC X 1 1/2 HEX BOLT
8	4	900391	3/4UNC X 1 1/2 FLT SOC CAP SCR
9	8	900395	1"UNC X 2 1/2 SOCKET CAP SCR
10	8	910101	1" UNC HEX JAM NUT
11	8	920002	3/8 SAE FLAT WASHER
12	8	920502	3/8 LOCK WASHER
13	8	920504	1/2 LOCK WASHER
14	1	361579	REAR TRD ADJ ACCESS PLT WLD
15	1	361576	FRT TREAD ADJ ACCESS PLT WLD
16	2	361581	TRD ADJ CYL PIVOT PIN, M/F
17	4	361583	TRD ADJ CYL SPACER, M/F
18	2	361582	TREAD ADJ CYL PIN, OUTER LEG
19	4	342719	TRD ADJ BRONZE BEARING, TAPPED
20	4	342721	TRD ADJ BRONZE BRG

MAINFRAME

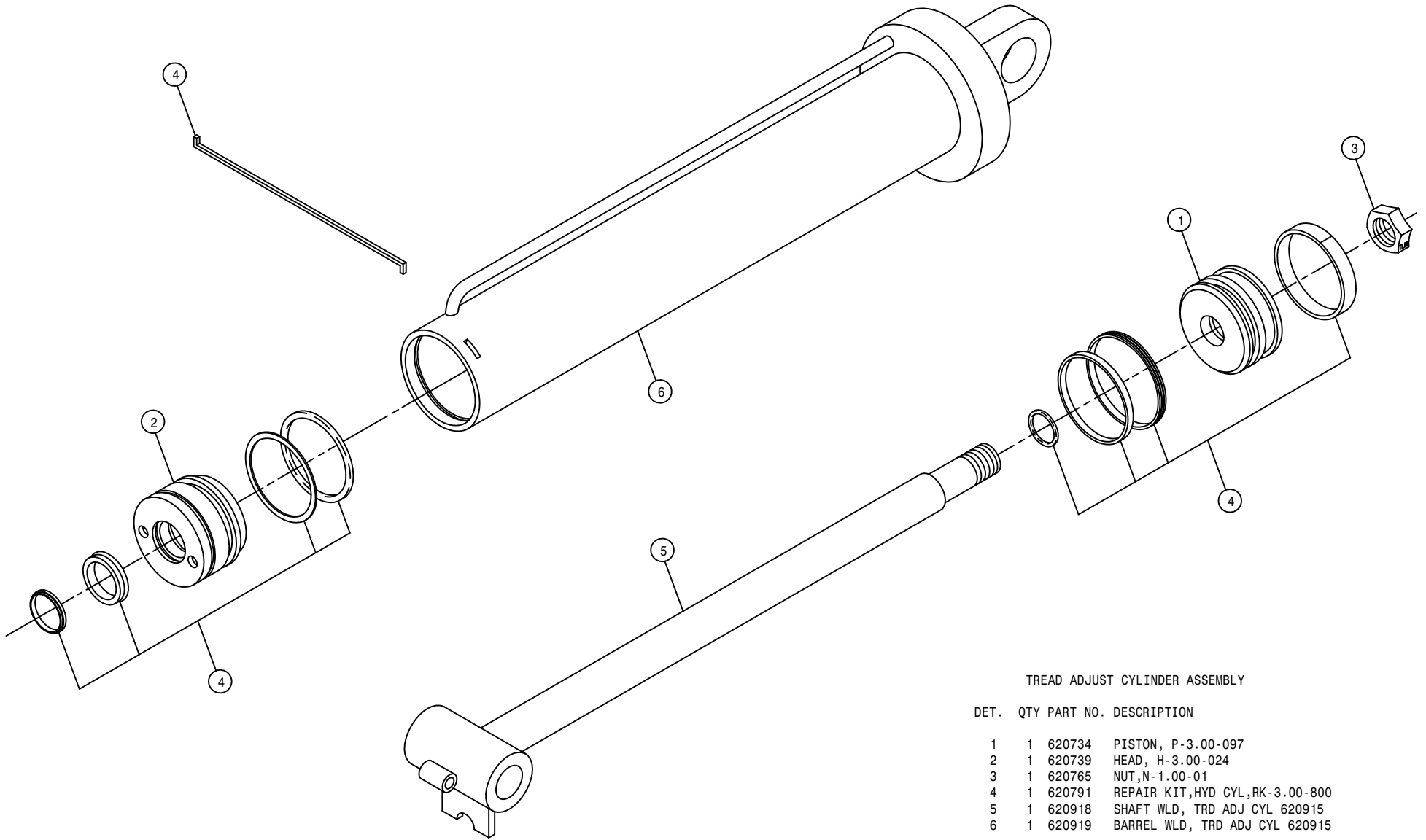

TREAD ADJUST CYLINDER ASSEMBLY

DET.	QTY	PART NO.	DESCRIPTION
	1	620734	PISTON, P-3.00-097
	1	620739	HEAD, H-3.00-024
	1	620765	NUT,N-1.00-01
	1	620791	REPAIR KIT, HYD CYL, RK-3.00-800
	1	620918	SHAFT WLD, TRD ADJ CYL 620915
	1	620919	BARREL WLD, TRD ADJ CYL 620915

NOTE: 1. 620915 - TREAD ADJUST CYLINDER ASSEMBLY ITEMS 1-6
 2. 621051 - TREAD ADJUST CYLINDER ASSEMBLY

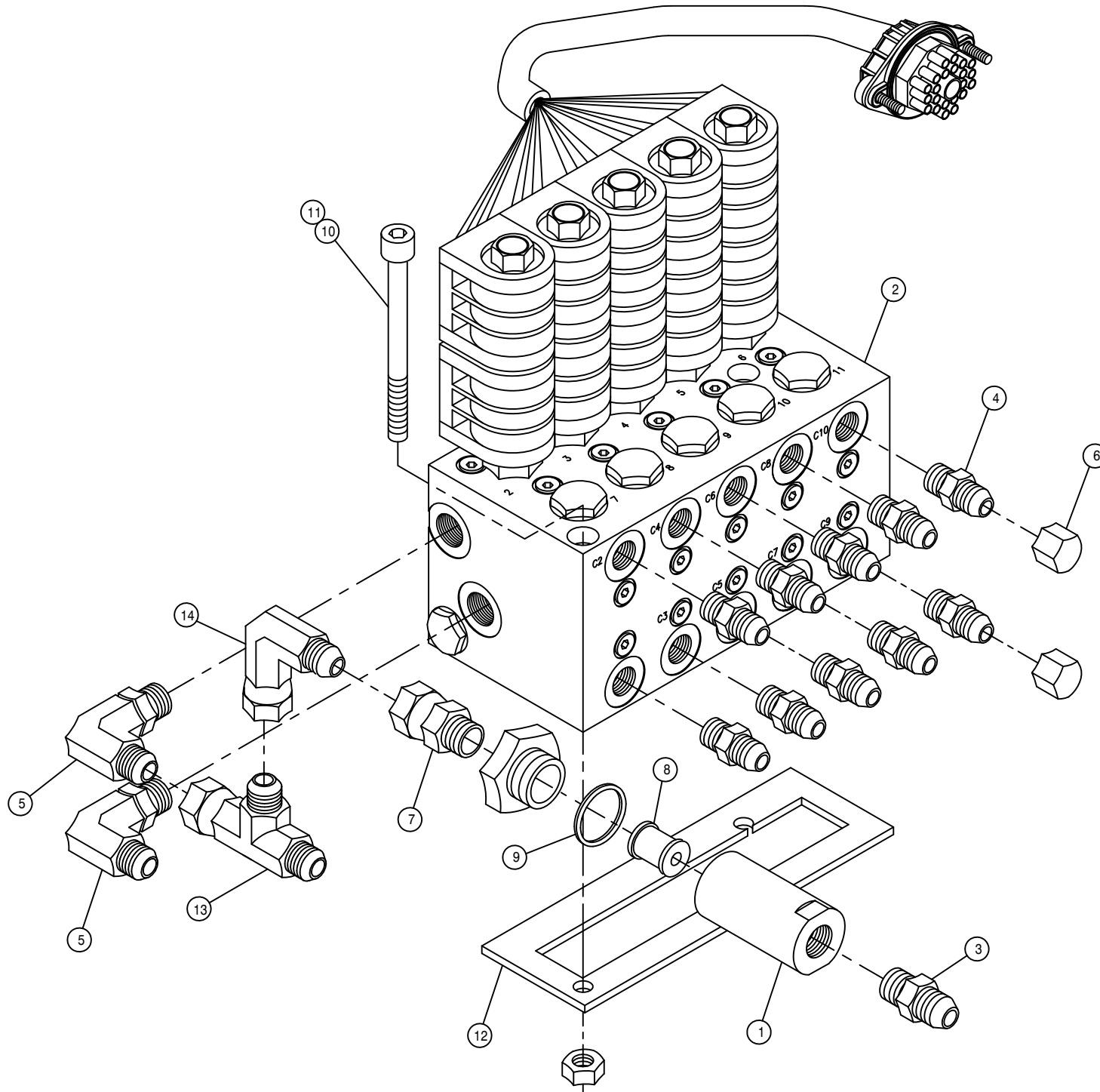

TREAD ADJ HYD MANIFOLD ASSEMBLY

DET.	QTY	PART NO.	DESCRIPTION
1	1	605610	HYD FILTER, INLINE 90M 3/4FOR
2	1	606050	DELTA HYD MANIFOLD ASSY, 2704
3	1	611125	3/4MJIC-3/4MOR ADPTR
4	10	618126	9/16MJIC-9/16MOR ADPTR
5	2	618241	3/4MJIC-90-3/4MOR LBO
6	2	618531	9/16FJIC CAP NUT
7	1	618669	3/4FJIC SWIV-3/4MOR ADPTR
8	1	610459	90M FILTER & GASKET FOR610447
9	1	610462	GASKET FOR 610447 ARROW FILT
10	2	900145	3/8UNC X 5 SOCKET HD CAP SCR
11	2	914004	3/8UNC HEX STOVER NUT
12	1	342825	TREAD ADJ VLV SPACER
13	1	618451	3/4FJIC SW RUN TEE-3/4MJIC
14	1	618609	3/4MJIC-90-3/4FJIC SWIV LBO

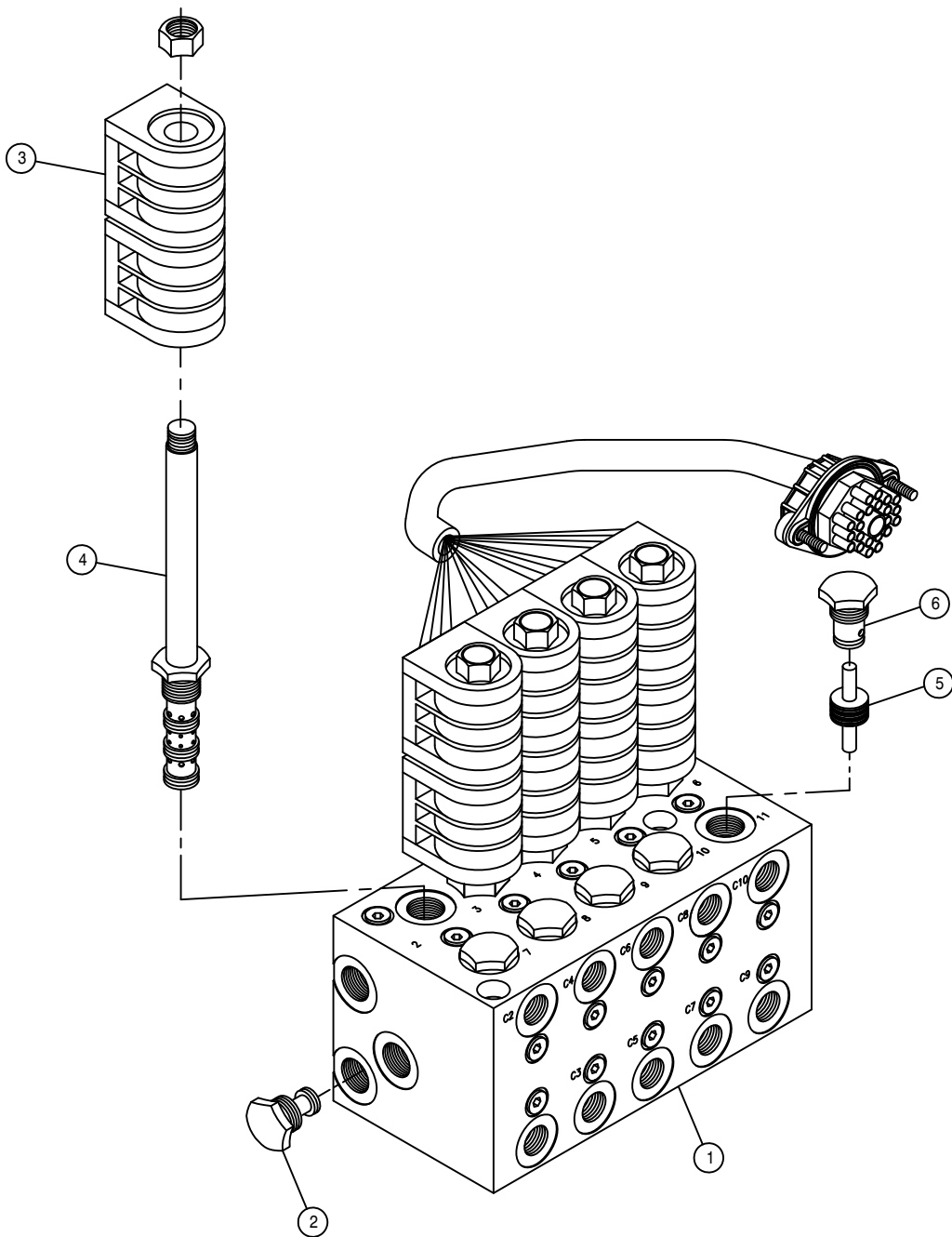

TREAD ADJUST HYD VALVE ASSEMBLY

DET.	QTY	PART NO.	DESCRIPTION
1	1	606050	DELTA HYD MANIFOLD ASSY, 2704
2	1	606073	CAVITY PLUG, DELTA VLV 606050
3	10	606056	COIL (63900502) FOR 606050/051
4	5	606057	SOLE VLV(DGS4M00)FOR 606050/51
5	5	606058	PISTON ASSY FOR 606050
6	10	606059	CHECK VALVE FOR 606050

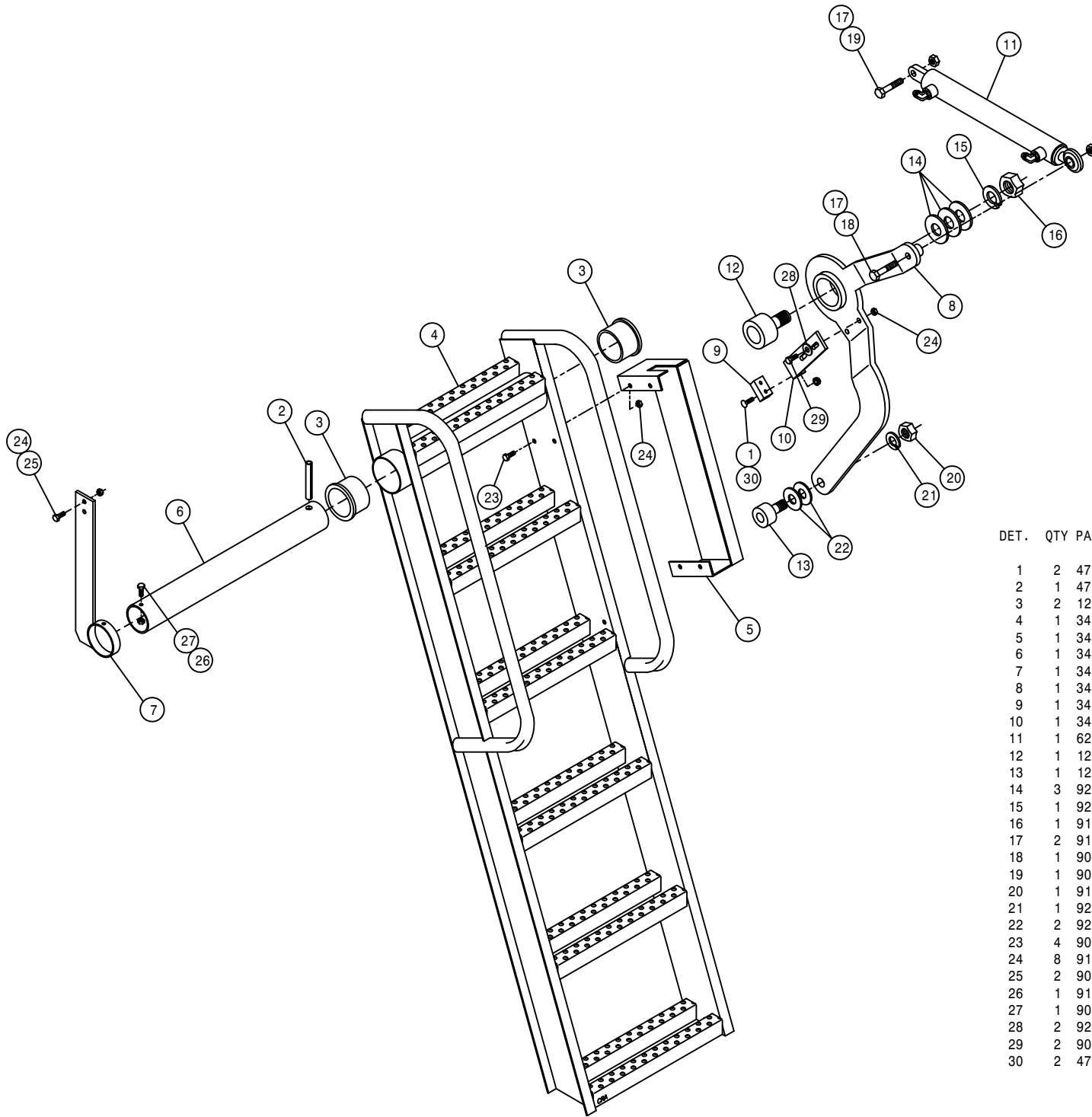

LADDER ASSEMBLY

DET.	QTY	PART NO.	DESCRIPTION
1	2	472017	1/4UNC X 1" SLOT FLT HD SCR
2	1	473978	ROLL PIN, 1/2 X 3 1/2 LG
3	2	121102	LADDER PIVOT BEARING, ORKOT
4	1	342817	LADDER WLD
5	1	342811	LADDER HINGE GUARD
6	1	342805	LADDER MT TUBE
7	1	342806	LH PLTFRM SUPP BRKT WLD, STS12
8	1	342813	LADDER PIVOT ARM WLD
9	1	342810	LADDER BUMPER STOP, POLY
10	1	342809	LADDER BUMPER MT
11	1	621052	LADDER, SIDE FILL CYL ASSYSTS12
12	1	125055	TRACK ROLLER, 2.500D, 1.00-16THD
13	1	125054	TRACK ROLLER, 1.750D, .75-16THD
14	3	920008	1" SAE FLAT WASHER
15	1	920508	1" LOCK WASHER
16	1	910016	1" UNF HEX NUT
17	2	914008	1/2UNC HEX STOVER NUT
18	1	900271	1/2UNC X 3 1/4 HEX BOLT
19	1	900267	1/2UNC X 2" HEX BOLT
20	1	910013	3/4UNF HEX NUT
21	1	920506	3/4 LOCK WASHER
22	2	920006	3/4 SAE FLAT WASHER
23	4	900064	5/16UNC X 3/4 HEX BOLT
24	8	914002	5/16UNC HEX STOVER NUT
25	2	900065	5/16UNC X 1" HEX BOLT
26	1	914000	1/4UNC HEX STOVER NUT
27	1	900003	1/4UNC X 1" HEX BOLT
28	2	920001	5/16 SAE FLAT WASHER
29	2	900066	5/16UNC X 1 1/4 HEX BOLT
30	2	470121	1/4UNC HEX FLANGE LOCK NUT

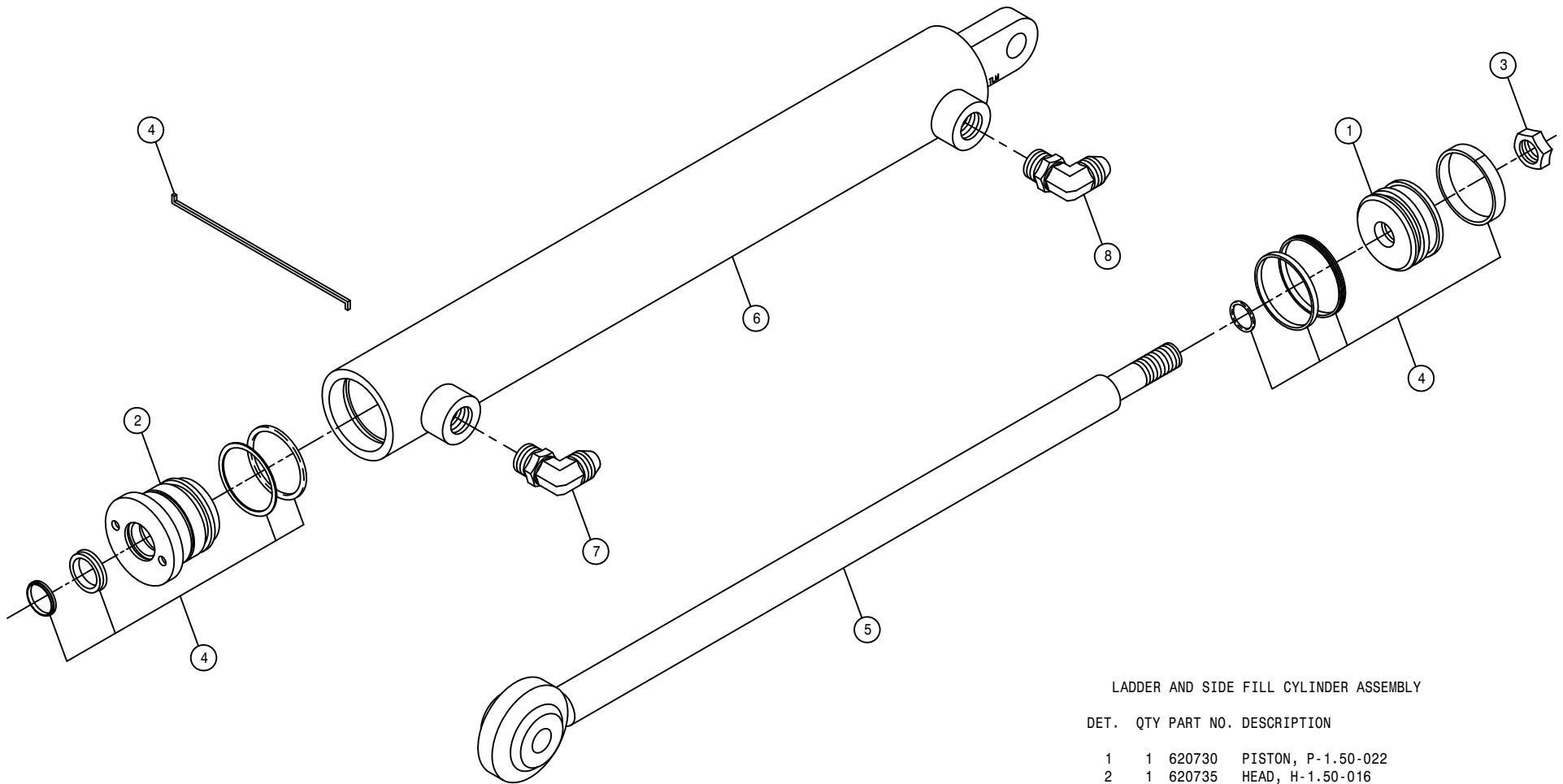

LADDER AND SIDE FILL CYLINDER ASSEMBLY

DET.	QTY	PART NO.	DESCRIPTION
1	1	620730	PISTON, P-1.50-022
2	1	620735	HEAD, H-1.50-016
3	1	620752	NUT, N-0.50-01
4	1	620786	REPAIR KIT, HYD CYL, RK-1.50-801
5	1	620923	SHAFT WLD, LADDER CYL 620920
6	1	620924	BARREL WLD, LADDER CYL 620920
7	1	614750	.042 ELBOW ASSY, 9/16MOR 90D
8	1	618119	9/16MJIC-90-9/16MOR LBO

NOTE: 1. 620920 - LADDER & SIDE FILL CYLINDER ASSEMBLY ITEMS 1-6
 2. 621052 - LADDER & SIDE FILL CYLINDER ASSEMBLY WITH FITTINGS

AIR TANK ASSEMBLY

DET. QTY PART NO. DESCRIPTION

1	2	319559	DRAIN COCK, 1/4MNPT EXT ST BRS
2	1	711050	3/4"FNPT CHECK VALVE S.S.
3	1	618713	3/4MNPT-90-3/4MNPT LBO
4	1	504804	BLK PIPE NIPPLE .75NPT-4.00
5	1	504900	PIPE PLUG .75NPT SQ HD
6	2	701154	AIR TANK
7	1	503013	RED BUSH 3/4MNPT-1/2FNPT, STEEL
8	1	711037	1/2MNPT-1/2 NYL TUBE FTG
9	1	711041	3/8MNPT-3/8 NYL TUBE LBO
10	2	711045	3/8MNPT-1/4 NYL TUBE DBL LBO
11	1	711046	3/8MNPT-1/4 NYL TUBE TRPL LBO
12	1	601476	HOSE, 1/4 X 120 AIR
13	1	601477	HOSE, 1/4 X 160 AIR
14	1	601478	HOSE, 1/4 X 175 AIR
15	1	601479	HOSE, 1/4 X 196 AIR
16	1	601480	HOSE, 1/4 X 230 AIR
17	1	601482	HOSE, 3/8 X 80 AIR
18	1	601483	HOSE, 1/2 X 84 AIR
19	1	601486	HOSE, 1/4 X 215 AIR
20	1	601487	HOSE, 1/4 X 235 AIR
21	8	900130	3/8UNC X 1 1/4 HEX BOLT
22	8	914004	3/8UNC HEX STOVER NUT
23	16	920002	3/8 SAE FLAT WASHER

38

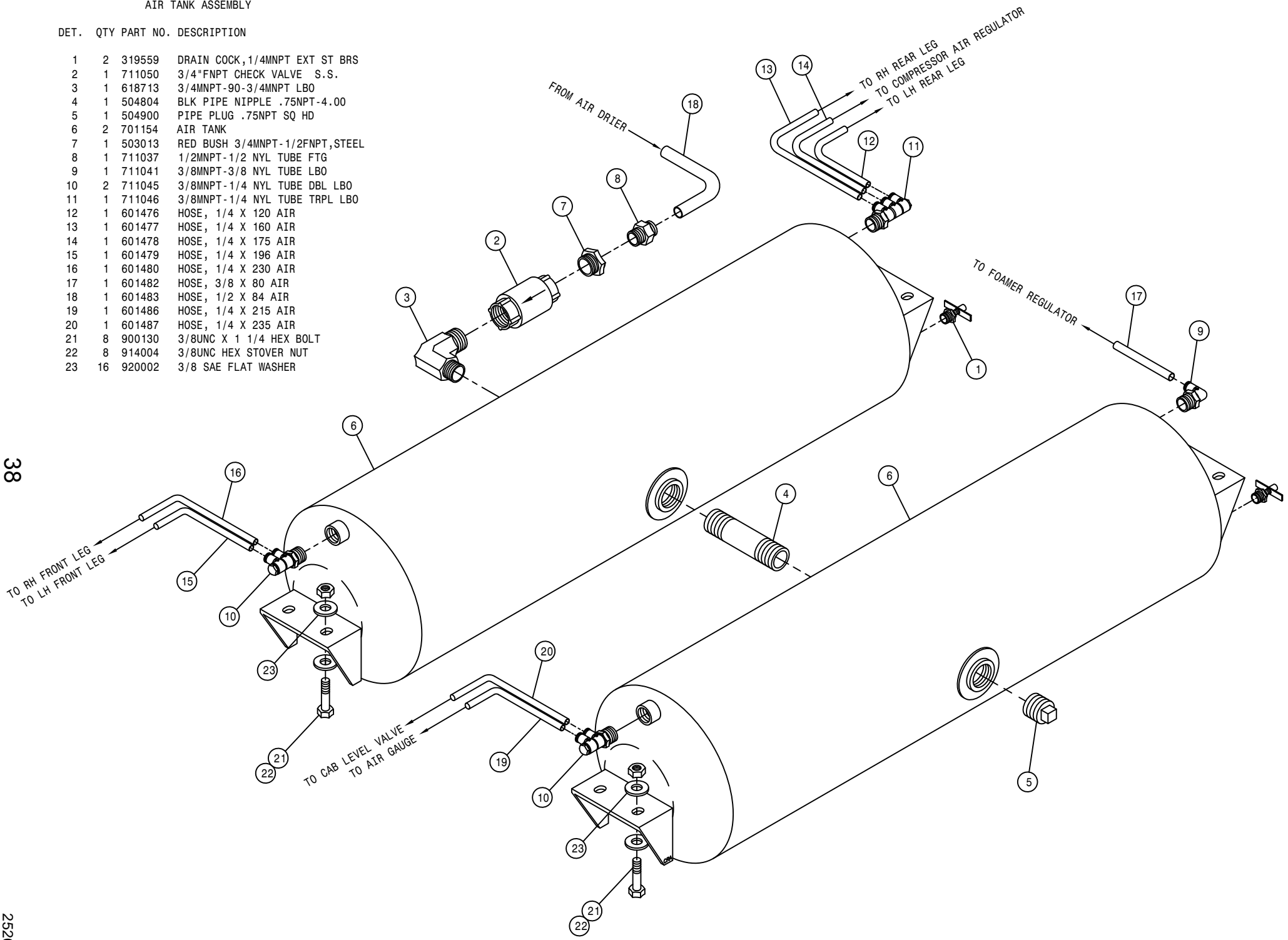

252038

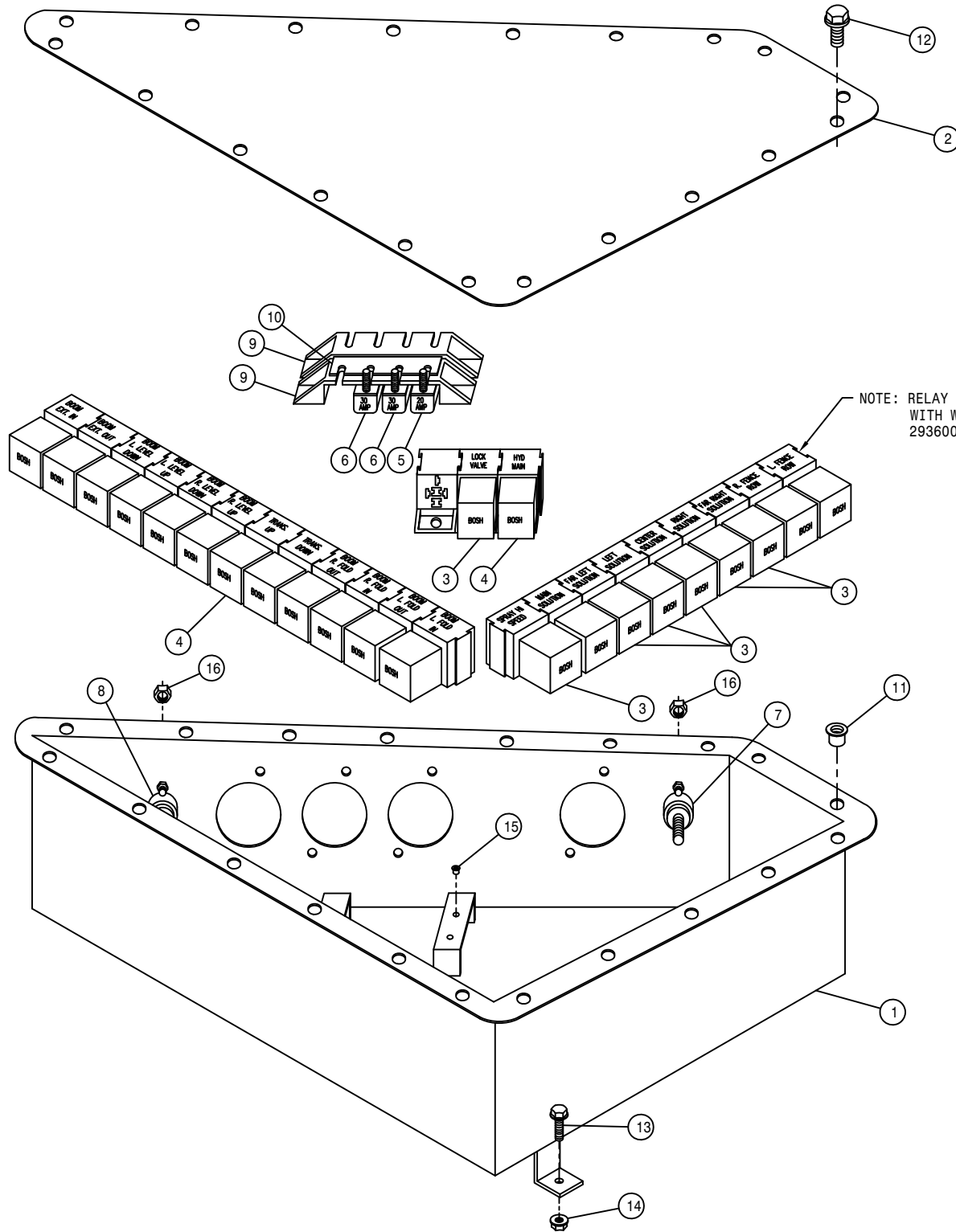

BOOM ELECTRICAL BOX ASSEMBLY

DET.	QTY	PART NO.	DESCRIPTION
	1	342830	BOOM ELECTRICAL BOX WLD
	1	342837	BOOM ELECTRICAL BOX COVER
	3	291752	RELAY, SPDT 12V 50A-NO 5-TERM
	4	291751	RELAY, SPST 12V 40A-NO 5-TERM
	5	291573	CIRCUIT BREAKER,20AMP W/O MT
	6	291574	CIRCUIT BREAKER,30AMP W/O MT
	7	291750	TERM BLOCK,RED,3/8-16 THRU
	8	291749	TERM BLOCK,BLACK,3/8-16 THRU
	9	291755	BREAKER MTG BRKT, 4-GANG NYLON
	10	291756	BUS BAR,4-GANG FOR 291755
	11	470086	1/4UNC NUTSERT .020-.100MATL
	12	470122	1/4UNC X 1/2 FLANGE HEX BOLT
	13	470118	1/4UNC X 3/4 FLANGE HEX BOLT
	14	470121	1/4UNC HEX FLANGE LOCK NUT
	15	470165	10-32 NUTSERT .020-.100 MATL
	16	910004	3/8UNC HEX NUT

NOTE: ALL RELAY BASES AND FUSE BLOCKS
COME WITH WIRE HARNESS
293626 - ENGINE BOX HARNESS

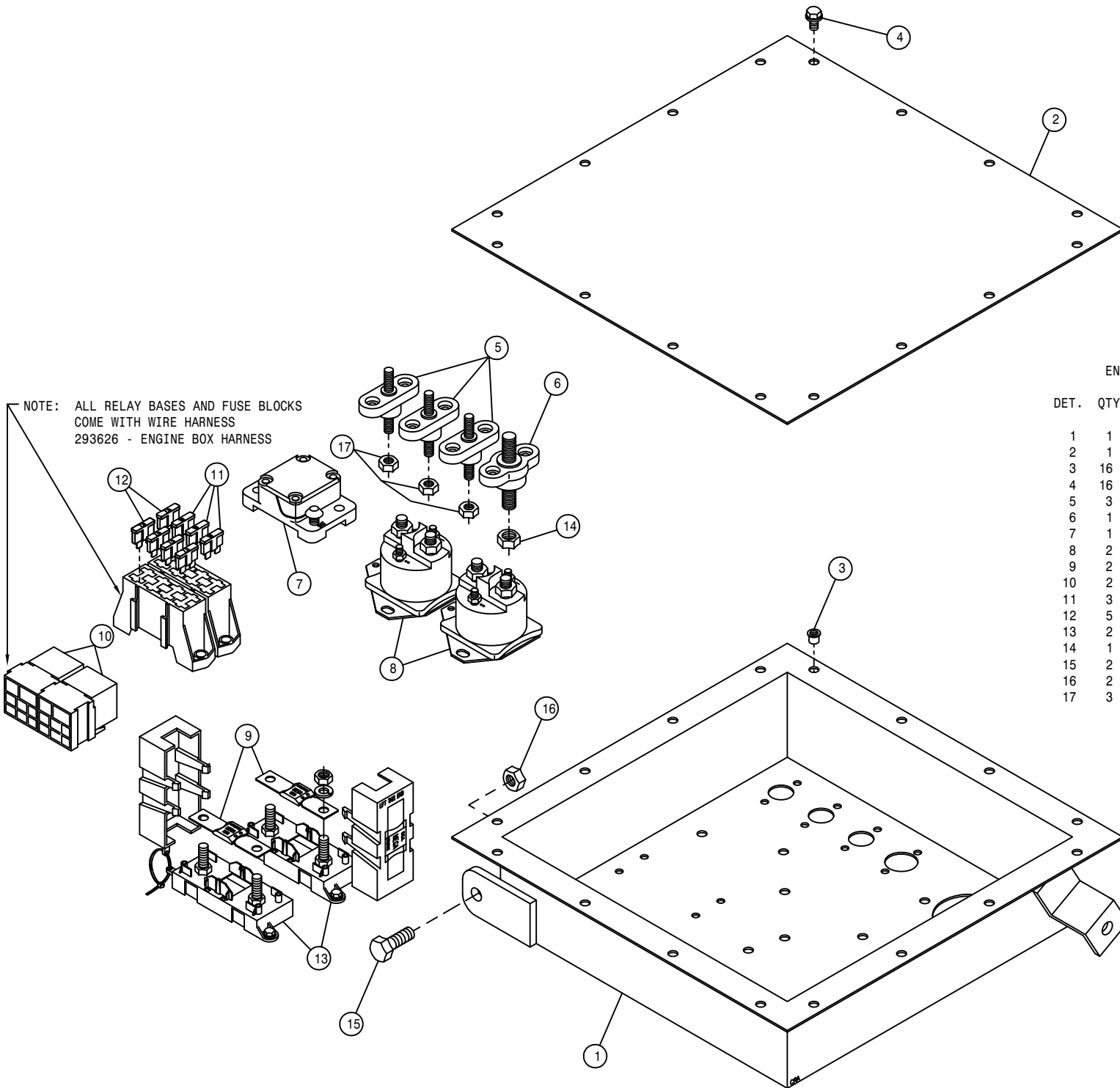

ENGINE ELECTRICAL BOX ASSEMBLY

DET.	QTY	PART NO.	DESCRIPTION
	1	342851	ENG ELECTRICAL BOX WLD
	1	342855	ENG ELECTRICAL BOX COVER
	16	470086	1/4UNC NUTSERT .020-.100MATL
	16	470122	1/4UNC X 1/2 FLANGE HEX BOLT
	3	291748	TERM BLOCK, BLACK, 1/4-20 THRU
	1	291750	TERM BLOCK, RED, 3/8-16 THRU
	1	291815	CIRCUIT BREAKER, 100 AMP BUSS
	2	291816	SOLENOID
	2	291813	125 AMP FUSE
	2	291751	RELAY, SPST 12V 40A-NO 5-TERM
	3	291545	10 AMP FUSE, 1/4" BLADE ATO/ATC
	5	291027	7.5 AMP FUSE, 1/4" BLADE ATO/ATC
	2	291814	FUSE HOLDER, HIGH AMP
	1	910004	3/8UNC HEX NUT
	2	900129	3/8UNC X 1" HEX BOLT
	2	914004	3/8UNC HEX STOVER NUT
	3	470121	1/4UNC HEX FLANGE LOCK NUT

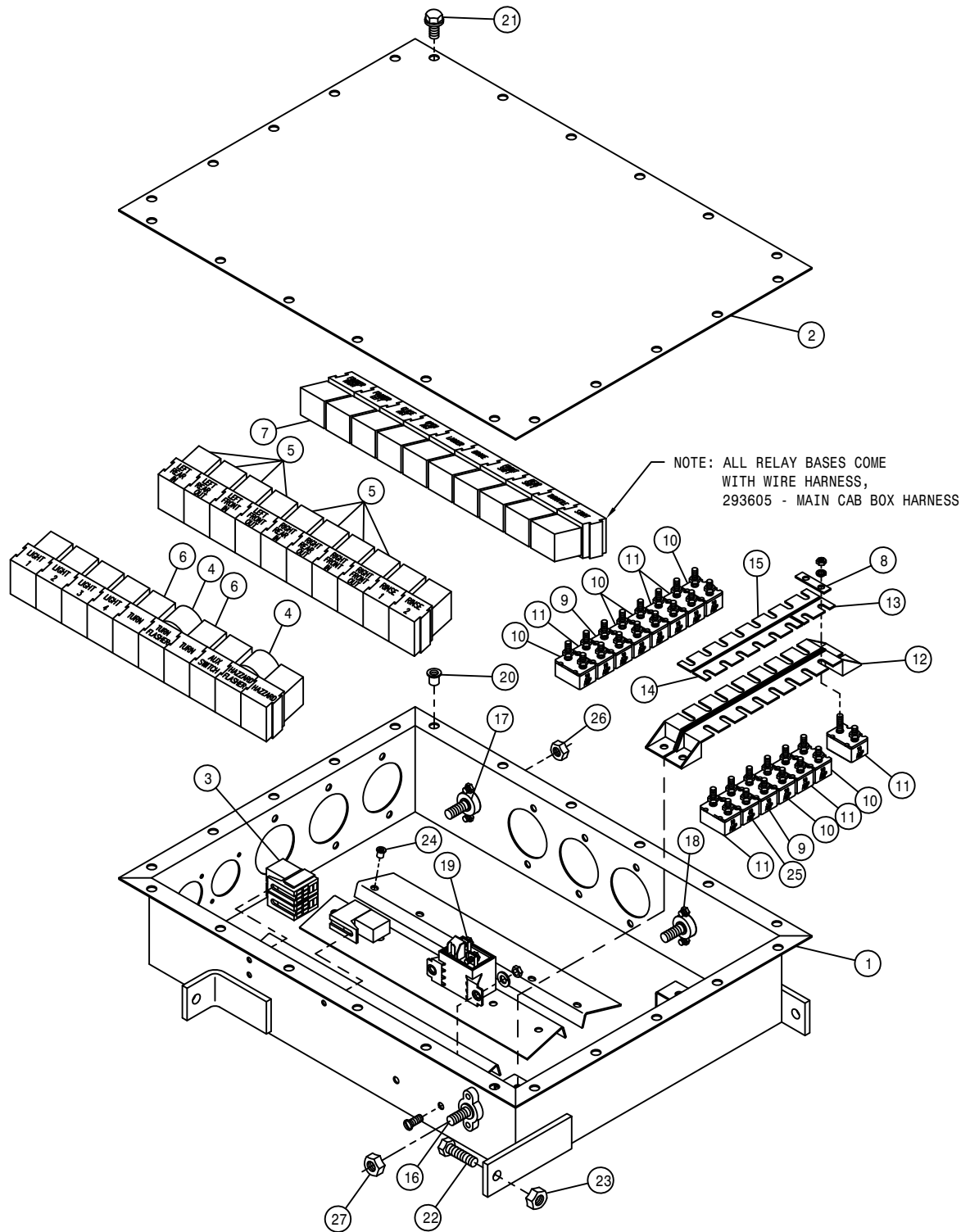

CAB ELECTRICAL BOX ASSEMBLY

DET.	QTY	PART NO.	DESCRIPTION
	1	342841	CAB ELECTRICAL BOX WLD
	1	342847	CAB ELECTRICAL BOX COVER
	3	291781	MICRO RELAY, BOSCH 12V SPDT
	2	291564	FLASHER, 12V 3-PIN ELECTRONIC
	8	291698	RELAY, TYPE V4 12VDC 30A
	2	291752	RELAY, SPDT 12V 50A-NO 5-TERM
	18	291751	RELAY, SPST 12V 40A-NO 5-TERM
	1	291683	BUSS BAR, 2 GANG CIRCUIT BREAKR
	2	291574	CIRCUIT BREAKER, 30AMP W/O MT
	6	291573	CIRCUIT BREAKER, 20AMP W/O MT
	6	291575	CIRCUIT BREAKER, 10AMP W/O MT
	2	291757	BREAKER MTG BRKT, 8-GANG NYLON
	1	291796	BUSS BAR, 2-GANG FOR 291757
	1	291797	BUSS BAR, 6-GANG FOR 291757
	1	291758	BUS BAR, 8-GANG FOR 291757
	1	291748	TERM BLOCK, BLACK, 1/4-20 THRU
	1	291749	TERM BLOCK, BLACK, 3/8-16 THRU
	1	291750	TERM BLOCK, RED, 3/8-16 THRU
	1	657371	RELAY, 12 VOLT 75 AMP
	22	470086	1/4UNC NUTSERT .020-.100MATL
	22	470122	1/4UNC X 1/2 FLANGE HEX BOLT
	3	900129	3/8UNC X 1" HEX BOLT
	3	914004	3/8UNC HEX STOVER NUT
	16	470165	10-32 NUTSERT .020-.100 MATL
	1	291584	CIRCUIT BREAKER, 40AMP W/O MT
	2	910004	3/8UNC HEX NUT
	1	470121	1/4UNC HEX FLANGE LOCK NUT

CAB AIR BAG ASSEMBLY

DET.	QTY	PART NO.	DESCRIPTION
	1	2	311064 AIRIDE SPRING, 358-7002
	2	2	311065 SHOCK ABSORBER
	3	1	311067 HEIGHT CONTROL AIR VALVE
	4	1	311068 4.00 LEVER, CTRL AIR VLV 311067
	5	1	311070 LEVER SCREW, CTRL AIR VLV311067
	6	1	343000 CAB, NEW HOLLAND FX DISCOVERY
	7	32	485053 POP RIVET 3/16 X 3/8
	8	4	472335 3/8UNC X 2" STUD BOLT
	9	2	520064 HOSE CLAMP NO 64 STAINLESS
	10	2	611125 3/4MJIC-3/4MOR ADPTR
	11	1	618241 3/4MJIC-90-3/4MOR LBO
	12	1	618443 3/4MJIC-90-3/4MOR EX LG LBO
	13	1	657435 FILTER BOX W/FILTERS STS12
	14	1	749321 STEERING CONTROL MTR 14.1CI
	15	12	900002 1/4UNC X 3/4 HEX BOLT
	16	8	900065 5/16UNC X 1" HEX BOLT
	17	4	910004 3/8UNC HEX NUT
	18	8	914002 5/16UNC HEX STOVER NUT
	19	10	914000 1/4UNC HEX STOVER NUT
	20	6	920502 3/8 LOCK WASHER
	21	2	343013 REAR CAB AIR-RIDE MT WLD
	22	1	343019 CAB STABILIZER MT WLD
	23	1	343022 REAR CAB COVER PLATE
	24	1	343023 STEERING MTR SPACER STS12
	25	1	343024 AIR DUCT HOSE, 4" X 5" LG CLLPSD
	26	4	470118 1/4UNC X 3/4 FLANGE HEX BOLT
	27	8	470121 1/4UNC HEX FLANGE LOCK NUT
	28	2	472330 3/4UNF HEX JAM NUT
	29	4	520080 HOSE CLAMP NO 10 STAINLESS
	30	1	601465 HOSE, 5/8 X 19 HEATER
	31	1	601466 HOSE, 5/8 X 21 HEATER
	32	1	601484 HOSE, 1/4 X 10 AIR
	33	1	601485 HOSE, 1/4 X 55 AIR
	34	1	601487 HOSE, 1/4 X 235 AIR
	35	1	657442 A/C HOSE, 06-06F90-06M90-33"
	36	1	657445 A/C HOSE, 08-10F90-10M90-35"
	37	3	711039 1/8MNPT-1/4 NYL TUBE LBO
	38	1	711044 1/8MNPT-1/4 NYL TUBE DBL LBO
	39	2	900007 1/4UNC X 2" HEX BOLT
	40	2	900128 3/8UNC X 3/4 HEX BOLT
	41	2	900267 1/2UNC X 2" HEX BOLT
	42	4	900272 1/2UNC X 3 1/2 HEX BOLT
	43	6	914008 1/2UNC HEX STOVER NUT
	44	1	343068 CAB AIR VALVE MT
	45	1	343069 AIR VALVE ARM MT, CAB
	46	1	343070 CAB HEIGHT CTRL LINKAGE, STS12
	47	2	473976 ROD END, .50B, .50-20UNF RH MALE
	48	2	910009 1/2UNF HEX NUT
	49	1	343072 CAB STABILIZER ROD
	50	1	343025 CAB STEP PLATE
	51	3	343027 DIMMER SWITCH MT PLT
	52	1	343026 DIMMER SWITCH MT WLD
	53	1	290412 DIMMER SWITCH
	54	1	657436 PANEL FILTER FOR 657435
	55	1	657437 CHARCOAL FILTER FOR 657435
	56	1	343004 WINDSHIELD, STS12 CAB 2000
	57	4	470175 10-32 HEX FLANGE LOCK NUT
	58	4	903905 10-32X1 1/2 SLT RD HD MACH SCR
	59	2	343101 CAB HINGE PIN, DRILLED STS12
	60	2	291828 WORKLIGHT W/O BULB, CAB, STS12
	61	2	291829 WORKLIGHT BULB FOR 291828, STS
	62	6	470154 CABLE TIE, 11.75" BLK PLASTIC
	63	2	601552 HOSE, 1/2 X 4 CLEAR VINYL
	64	2	619014 1/2" HOSE MENDER
	65	2	657451 A/C KAZOO, 1/2" X 2" LONG
	66	1	291214 ANTENNA
	67	1	343118 A/C FILTER ELEMENT, CAB STS12

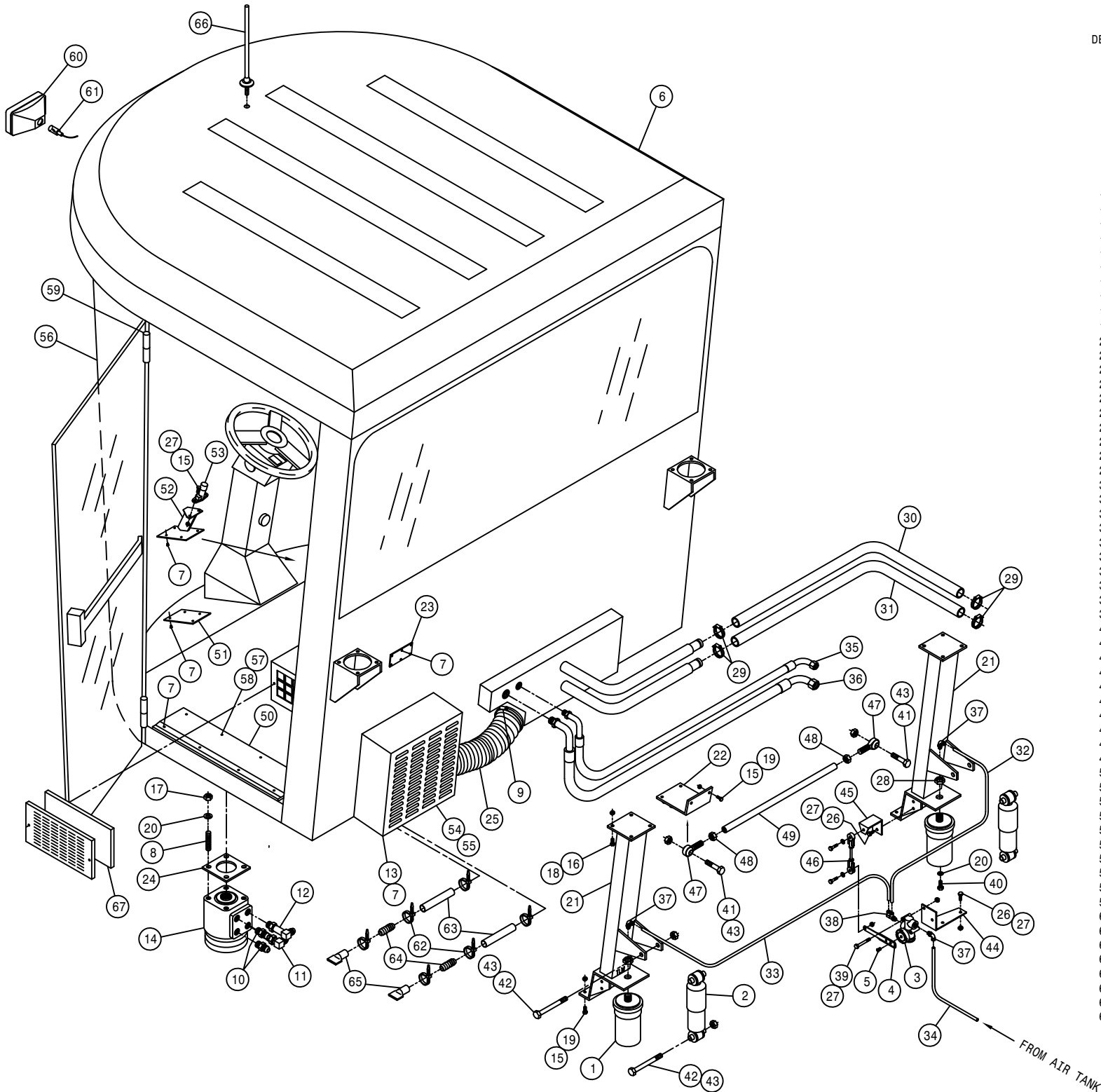

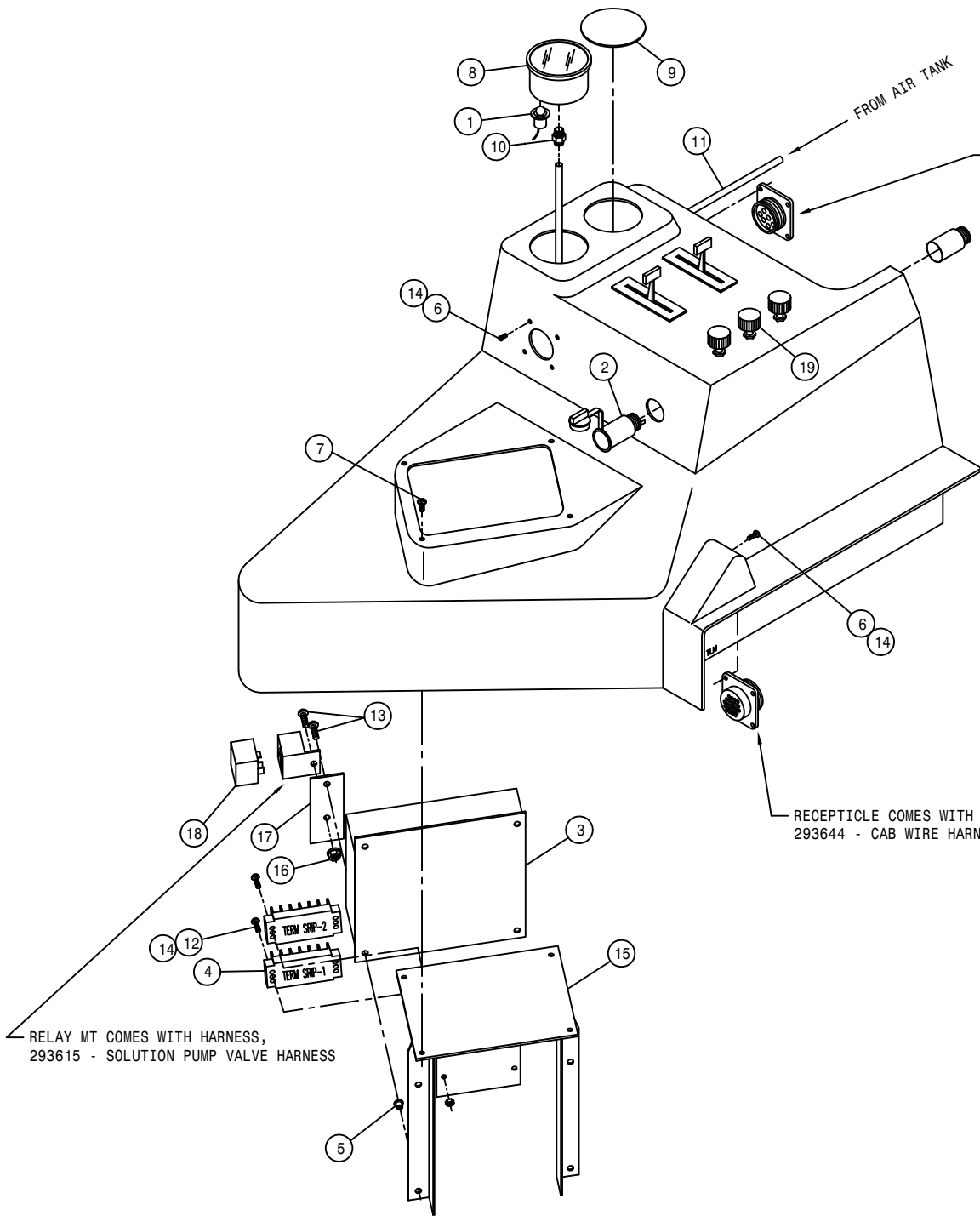

RECEPTACLE COMES WITH HARNESS,
293610 - DIAGNOSTIC READ HARNESS

RECEPTACLE COMES WITH HARNESS,
293644 - CAB WIRE HARNESS

RELAY MT COMES WITH HARNESS,
293615 - SOLUTION PUMP VALVE HARNESS

HEATER CONTROL PANEL ASSEMBLY

DET.	QTY	PART NO.	DESCRIPTION
1	1	291612	LIGHT KIT FOR 2" GAUGE
2	1	291648	POWER POINT RECEPTACLE
3	1	291787	INPUT MODULE, ATI
4	2	293093	TERMINAL BLOCK 6 POS - 2 ROW
5	4	470165	10-32 NUTSERT .020-.100 MATL
6	8	473989	6-32 X 3/4 BUTTON SOC CAP SCR
7	4	473990	8-15 X 3/4 PHIL PAN SMS TY-A
8	1	701311	AIR PRESS GAUGE, 150PSI, PNL MT
9	1	701312	GAUGE BLANK
10	1	711038	1/8FNPT-1/4 NYL TUBE FTG
11	1	601486	HOSE, 1/4 X 215 AIR
12	4	903814	6-32 X 3/4 SLT RD HD MACH SCR
13	5	903883	10-32 X 1/2 SLT RDHD MACH SCR
14	12	910022	6-32 HEX NUT
15	1	343062	CONSOLE COVER WLD, CAB
16	1	470175	10-32 HEX FLANGE LOCK NUT
17	1	343067	RELAY BRKT
18	1	291752	RELAY, SPDT 12V 50A-NO 5-TERM
19	1	343114	SWITCH, CAB FAN STS12 2000

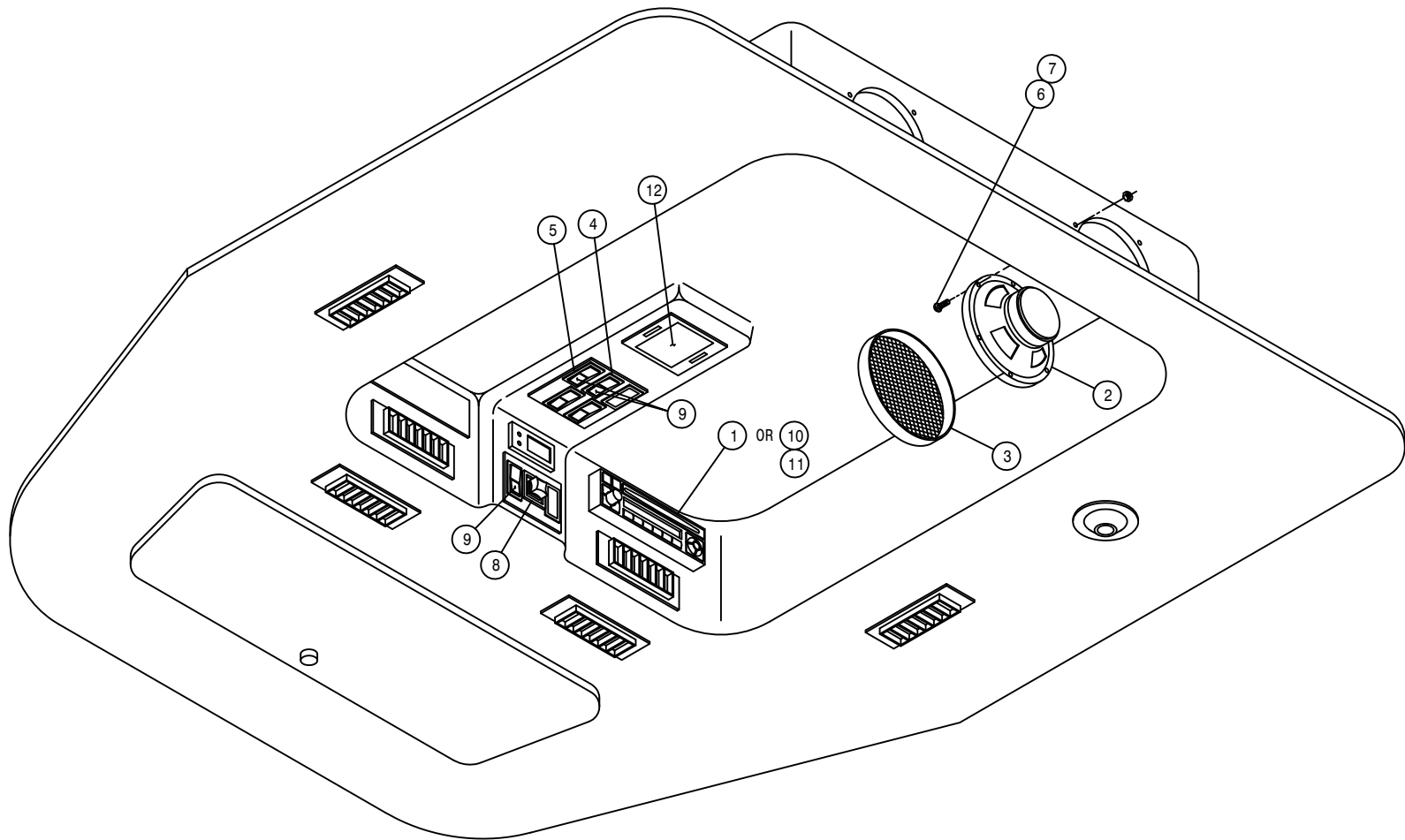

HEADLINER ASSEMBLY

DET. QTY PART NO. DESCRIPTION

1	1	291212	RADIO	94
2	2	291219	SPEAKER, 5 1/4"RD	
3	2	291319	SPEAKER GRILLE, ROUND SNAP ON	
4	1	291627	SWITCH,2P(ON)OFF(ON) 511-058	
5	1	291775	SWITCH, 511-172	
6	6	903812	6-32 X 1/2 SLT RD HD MACH SCR	
7	6	910022	6-32 HEX NUT	
8	1	291798	MIRROR SWITCH FOR 470316	
9	3	291628	LENS, GREEN	
10	1	291835	RADIO, AM/FM/CD/WB CRC-5320	
11	1	291836	WIRE HARNESS FOR 291835 RADIO	
12	1	343123	DOMELIGHT, CAB STS	

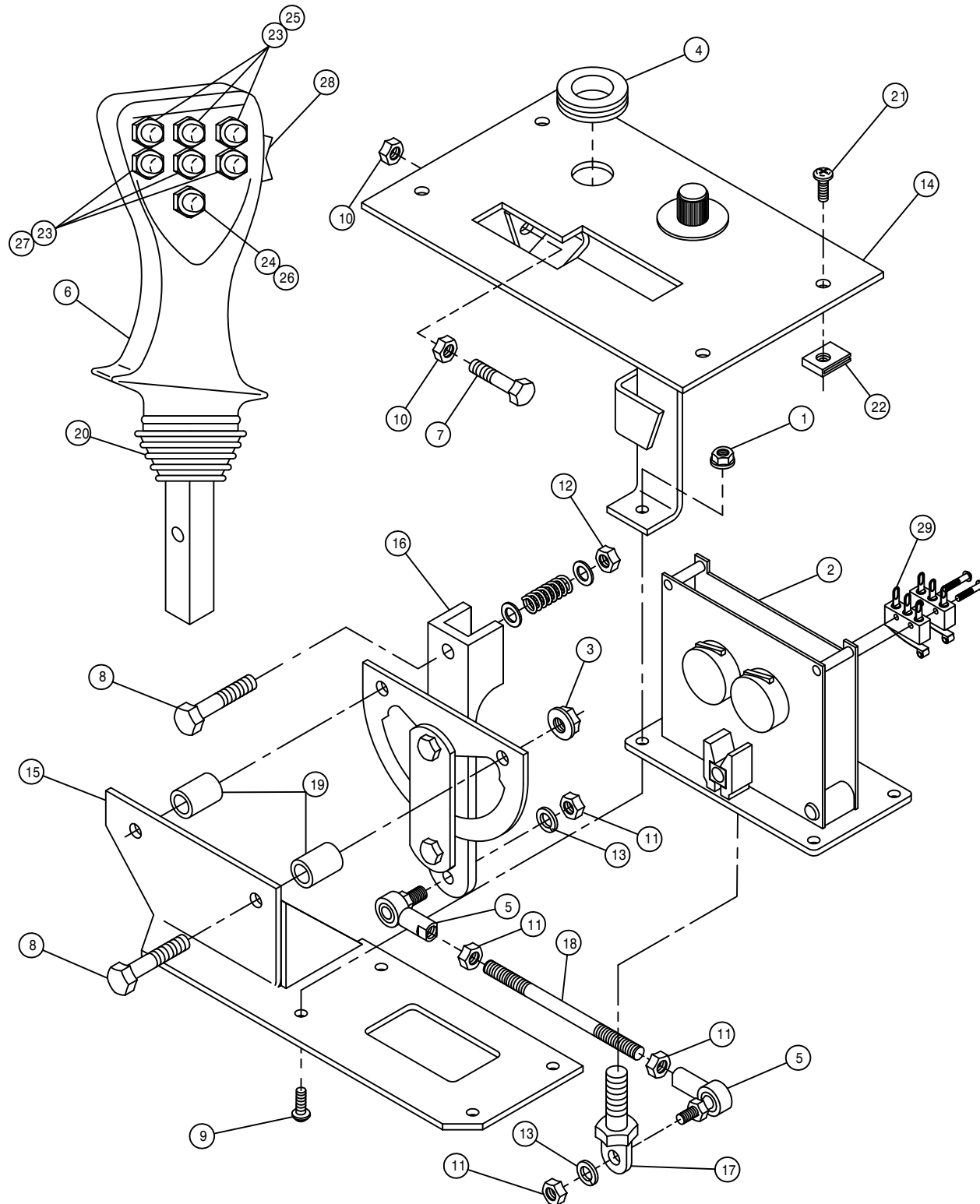

HYDROSTATIC CONTROL LEVER ASSEMBLY

DET.	QTY	PART NO.	DESCRIPTION
	1	4	169028 10-24 HEX FLANGE LOCK NUT
	2	1	291760 CONTROL HANDLE & POTENTIOMETER
	3	2	470121 1/4UNC HEX FLANGE LOCK NUT
	4	1	470296 GROMMET, .750ID .062GW 1.062GD
	5	2	473918 BALL JOINT 1/4 28 FEM STUDED
	6	1	785080 FASSE CTRL HANDLE, SCOOP GRIP
	7	2	900003 1/4UNC X 1" HEX BOLT
	8	3	900005 1/4UNC X 1 1/2 HEX BOLT
	9	4	903888 10-24 X 3/4 SLT RDHD MACH SCR
	10	4	910000 1/4UNC HEX NUT
	11	4	910001 1/4UNF HEX NUT
	12	1	914000 1/4UNC HEX STOVER NUT
	13	2	920500 1/4 LOCK WASHER
	14	1	343031 HYDRO LEVER MT PLT WLD
	15	1	343037 HYDRO LEVER MT WLD
	16	1	343040 HYDST CTRL LEVER STS12
	17	1	343041 HYDRO LINKAGE BOLT WLD
	18	1	343043 HYDRO LINKAGE ROD
	19	2	343044 HYDRO LEVER SPACER
	20	1	785081 BELLOW,FASSE CTRL HANDLE785080
	21	4	473990 8-15 X 3/4 PHIL PAN SMS TY-A
	22	4	470172 # 8 SPEED NUT
	23	6	291793 SWITCH,PB DPDT MOM MICRO
	24	1	291794 SWITCH,PB SPDT STAT MICRO
	25	3	291651 SWITCH BOOT, GRAY -FOR 291650
	26	1	291818 SWITCH BOOT 15/32 GREEN
	27	3	291652 SWITCH BOOT, RED -FOR 291650
	28	1	291826 SWITCH, SPDT RCKR 3P STAT
	29	4	291827 MICRO SWITCH FOR 291760

SWITCH PANEL ASSEMBLY

DET. QTY PART NO. DESCRIPTION

1	1	291772	SWITCH PANEL, 14 POS W/SW STS12
2	1	291622	SWITCH, 1P ON/OFF 511-003
3	1	291624	SWITCH, 2P (ON)/OFF 511-130
4	1	291625	SWITCH, 2P ON/ON 511-108
5	7	291627	SWITCH, 2P (ON)OFF (ON) 511-058
6	1	291671	SWITCH, 2P OFF/ONA/ONAB 511-138
7	2	291672	SWITCH, 1P ON/OFF/ON 511-149
8	1	291774	SWITCH, 511-024
9	1	291775	SWITCH, 511-172
10	2	291776	BLANK COVER
11	1	291832	AMP RECEPTCL, 17-3 STD, SQ FLG
12	1	291754	AMP RECEPTACLE CAP, 17-SHELL
13	18	473989	6-32 X 3/4 BUTTON SOC CAP SCR
14	18	910022	6-32 HEX NUT
15	1	291773	WARNING PANEL, 6 POSITION
16	1	321021	IGN SWITCH, NON-SEALED
17	2	291782	RELAY BASE, 5-PIN MICRO, PNL MT
18	2	291781	MICRO RELAY, BOSCH 12V SPDT
19	1	343047	RELAY BASE MT BRKT
20	2	920510	#10 LOCK WASHER
21	2	910026	10-24 HEX NUT
22	2	472199	10-24 X 1/2 RD HD MACH SCR
23	3	291628	LENS, GREEN
24	1	293645	PWR PORT PIGTAIL ASSY, STS 02

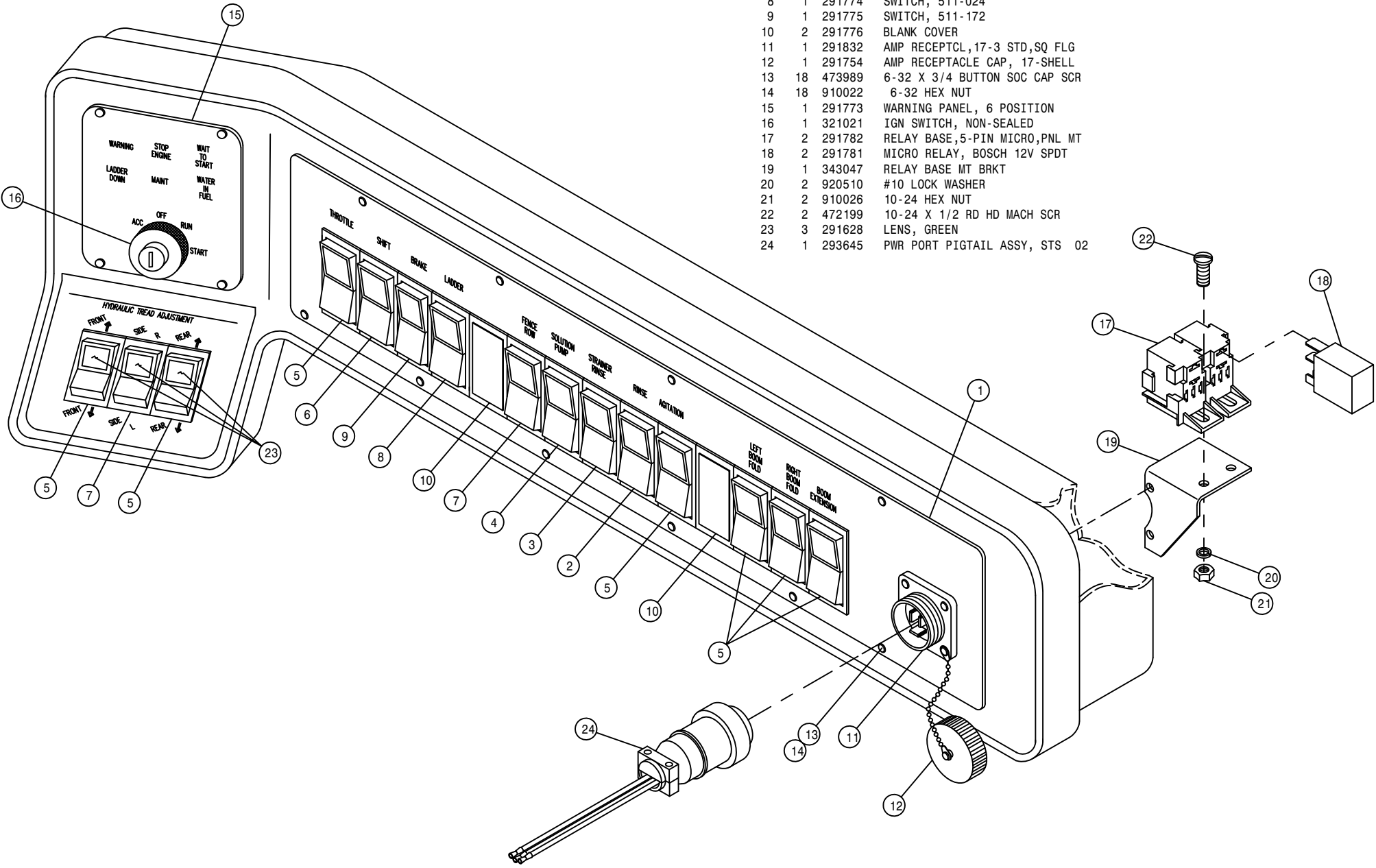

46

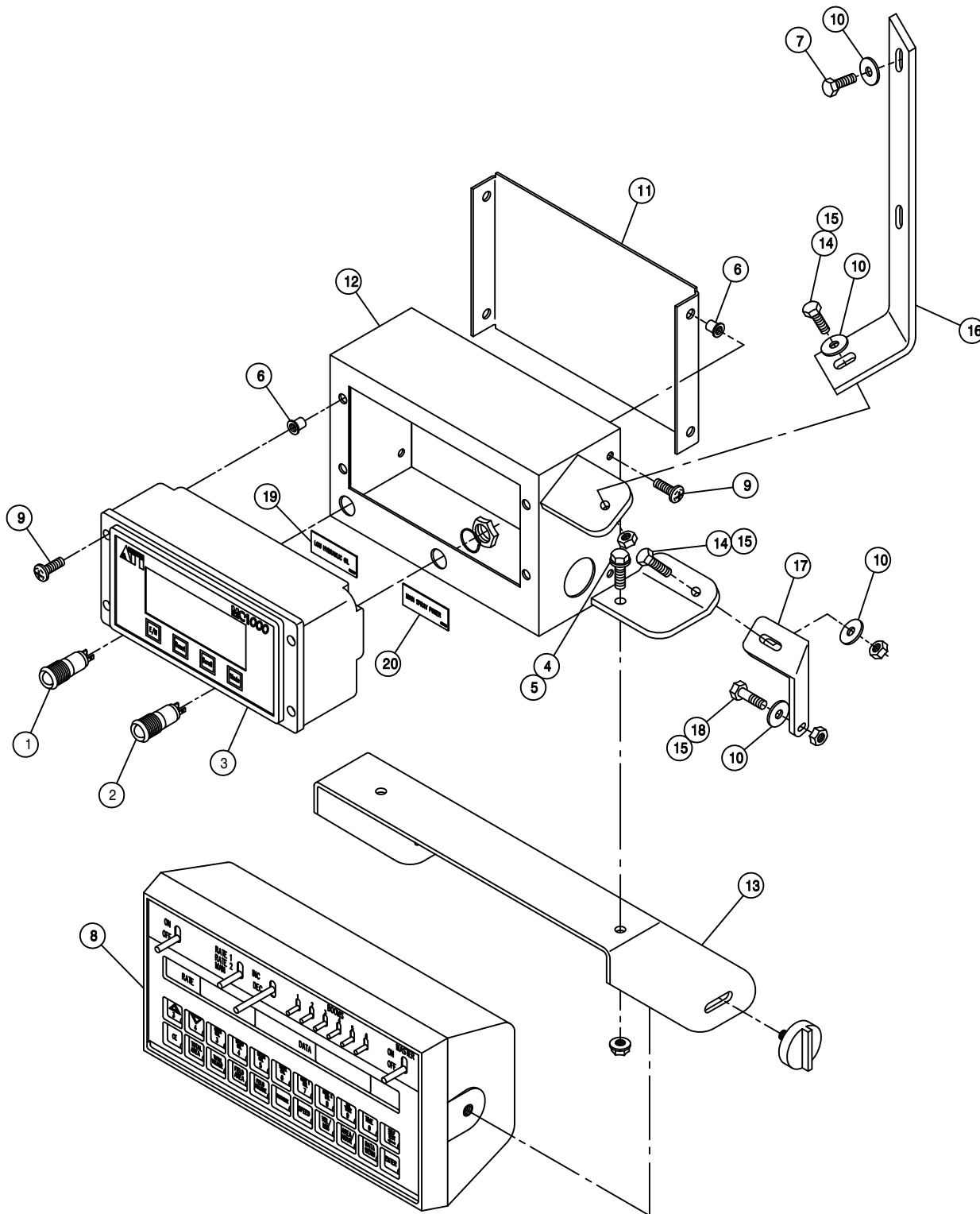

ATI MC1000 CONTROL BOX ASSEMBLY

DET. QTY PART NO. DESCRIPTION

1	1	291740	RED LED IND LIGHT, 12V 10MM
2	1	291741	GREEN LED IND LIGHT, 12V 10MM
3	1	291761	MESSAGE CENTER, ATI MC1000
4	2	470118	1/4UNC X 3/4 FLANGE HEX BOLT
5	2	470121	1/4UNC HEX FLANGE LOCK NUT
6	8	470165	10-32 NUTSERT .020-.100 MATL
7	2	473787	6MM-1.00 X 25MM HEX BOLT
8	1	690810	CONSOLE, RAVEN 450 W/GPS PORT
9	8	903710	10-32X5/8 PHIL PANHD MACH SCR
10	5	920000	1/4 SAE FLAT WASHER
11	1	343058	ATI MC1000 CTRL BOX COVER
12	1	343053	ATI MC1000 CTRL BOX WLD
13	1	343059	MONITOR MT BRKT, STS
14	2	900003	1/4UNC X 1" HEX BOLT
15	3	914000	1/4UNC HEX STOVER NUT
16	1	343060	ATI MC1000 CTRL BOX UPR SUPP
17	1	343061	ATI MC1000 CTRL BOX LWR SUPP
18	1	900004	1/4UNC X 1 1/4 HEX BOLT
19	1	650109	DECAL, LOW HYDRAULIC OIL
20	1	650108	DECAL, MAIN SPRAY POWER

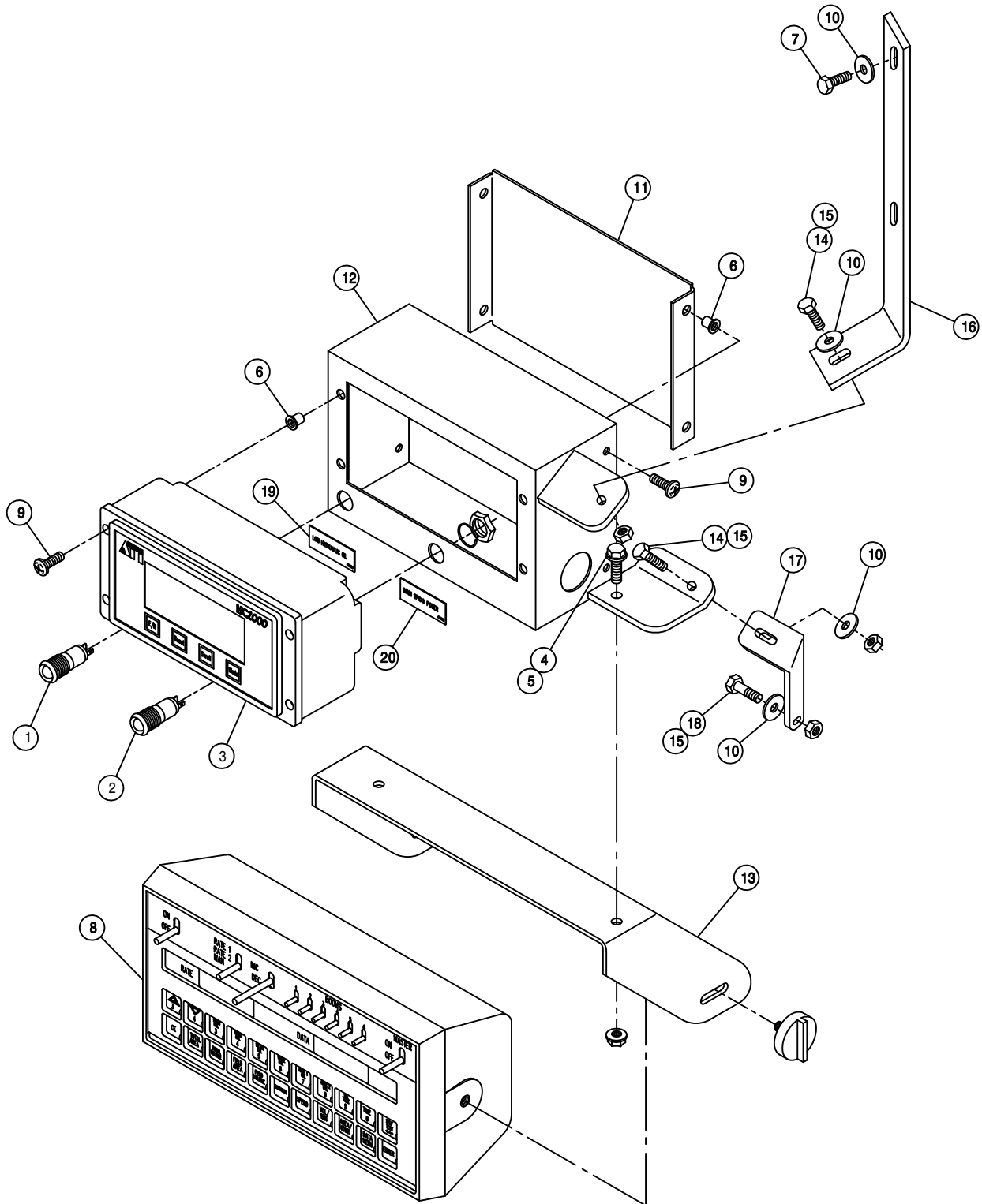

ATI MC2000 CONTROL BOX ASSEMBLY

DET. QTY PART NO. DESCRIPTION

1	1	291740	RED LED IND LIGHT,12V 10MM
2	1	291741	GREEN LED IND LIGHT,12V 10MM
3	1	291768	MESSAGE CENTER, ATI MC2000
4	2	470118	1/4UNC X 3/4 FLANGE HEX BOLT
5	2	470121	1/4UNC HEX FLANGE LOCK NUT
6	8	470165	10-32 NUTSERT .020-.100 MATL
7	2	473787	6MM-1.00 X 25MM HEX BOLT
8	1	690810	CONSOLE, RAVEN 450 W/GPS PORT
9	8	903710	10-32X5/8 PHIL PANHD MACH SCR
10	5	920000	1/4 SAE FLAT WASHER
11	1	343085	ATI MC2000 CTRL BOX COVER
12	1	343083	ATI MC2000 CTRL BOX WLD
13	1	343059	MONITOR MT BRKT
14	2	900003	1/4UNC X 1" HEX BOLT
15	3	914000	1/4UNC HEX STOVER NUT
16	1	343060	ATI MC1000 CTRL BOX UPR SUPP
17	1	343061	ATI MC1000 CTRL BOX LWR SUPP
18	1	900004	1/4UNC X 1 1/4 HEX BOLT
19	1	650109	DECAL, LOW HYDRAULIC OIL
20	1	650108	DECAL, MAIN SPRAY POWER

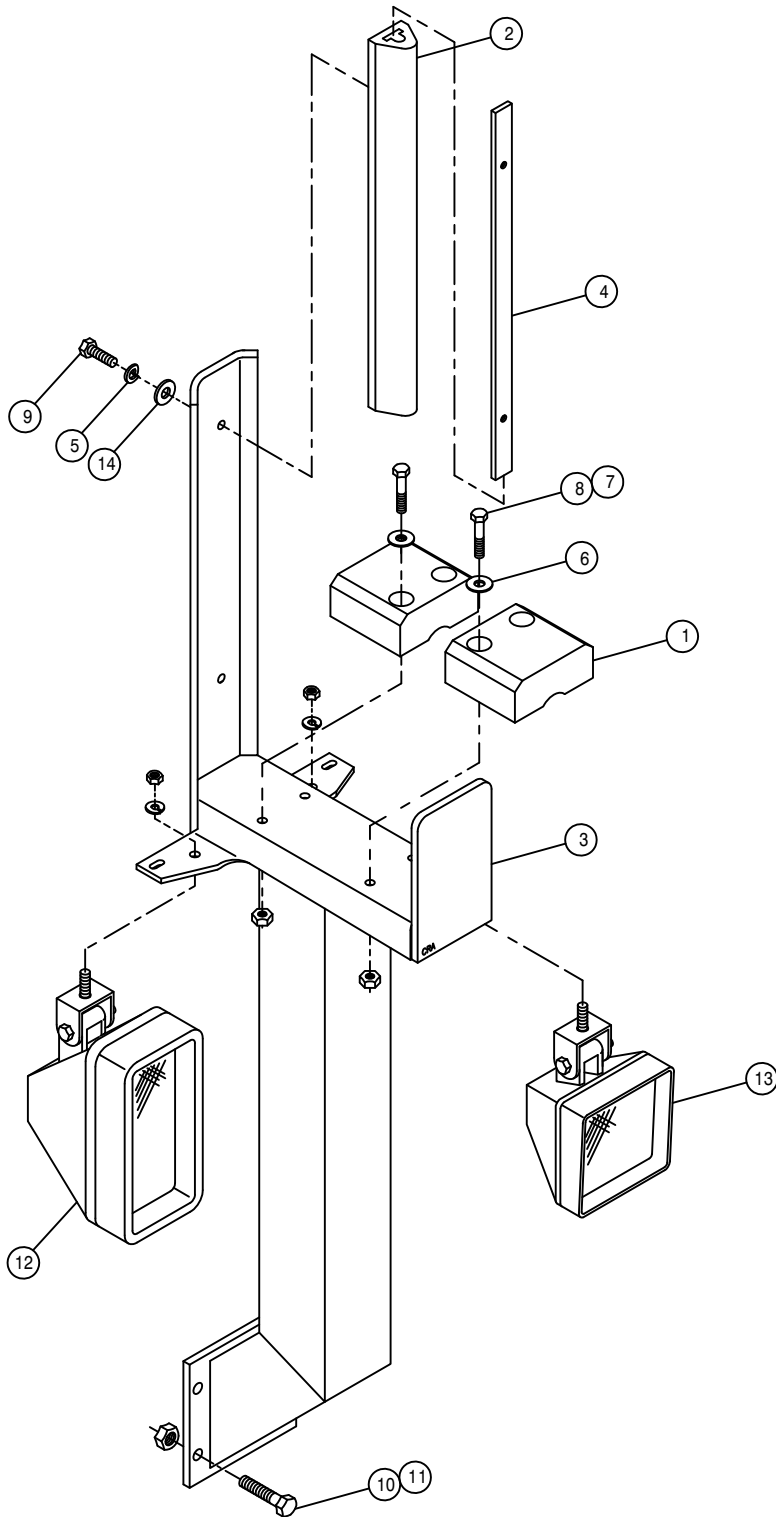

BOOM CRADLE ASSEMBLY

DET.	QTY	PART NO.	DESCRIPTION
1	4	164513	BOOM CRADLE PAD
2	2	164512	RUBBER BUMPER, BOOM CRADLE
3	2	164505	BOOM CRADLE WLD
4	2	164514	RUBBER BUMPER KEEPER PLT
5	4	920501	5/16 LOCK WASHER
6	8	920002	3/8 SAE FLAT WASHER
7	8	914004	3/8UNC HEX STOVER NUT
8	8	900133	3/8UNC X 2" HEX BOLT
9	4	900066	5/16UNC X 1 1/4 HEX BOLT
10	8	900265	1/2UNC X 1 1/2 HEX BOLT
11	4	914008	1/2UNC HEX STOVER NUT
12	2	291779	HALOGEN WORKLAMP,LH MT 12V55
13	2	291780	HALOGEN WORKLAMP,CNTR MT12V55
14	4	920001	5/16 SAE FLAT WASHER

*NOTE: QUANTITY LISTED IS FOR ONE MACHINE.

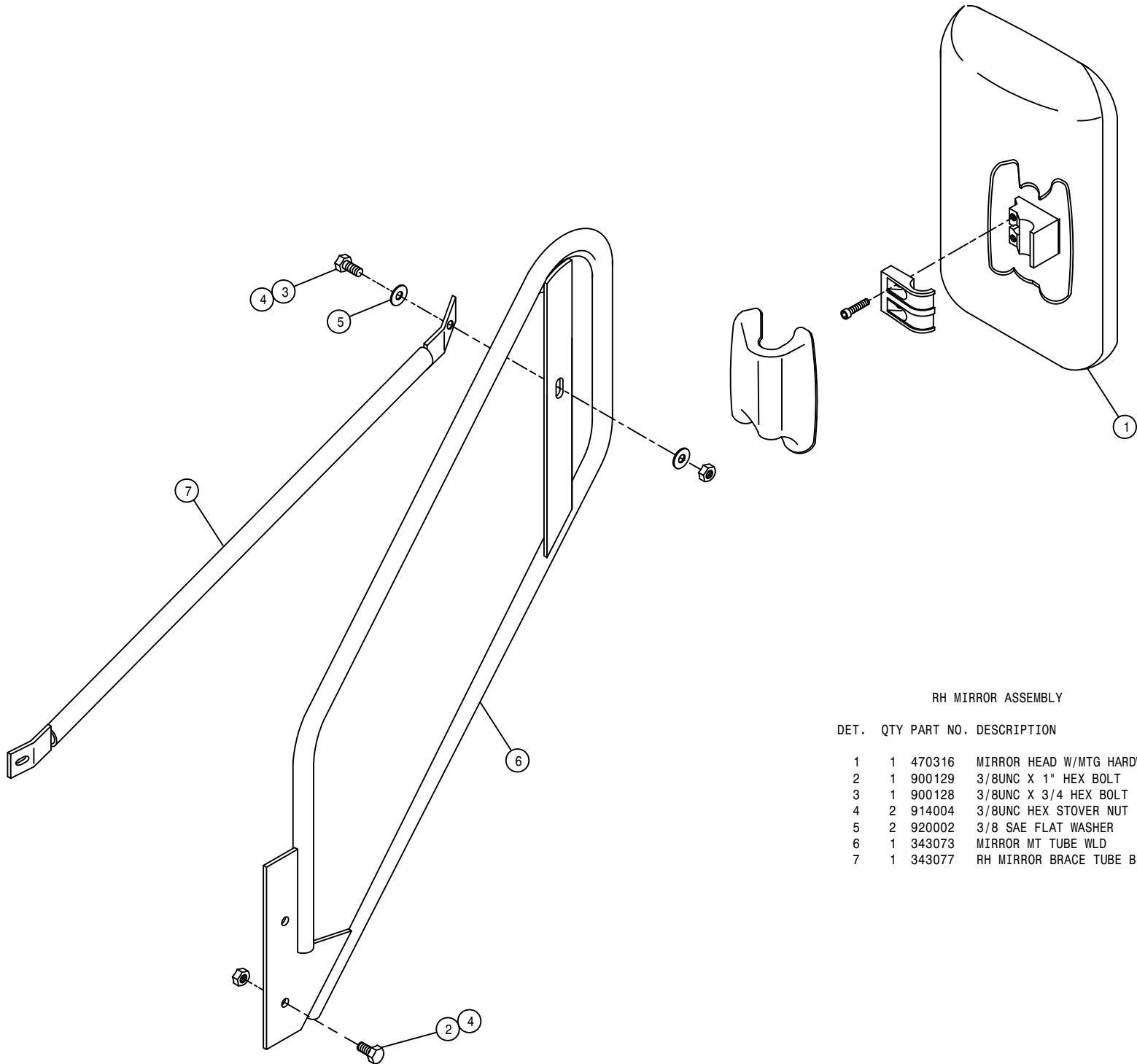

RH MIRROR ASSEMBLY

DET. QTY PART NO. DESCRIPTION

1	1	470316	MIRROR HEAD W/MTG HARDWARE
2	1	900129	3/8UNC X 1" HEX BOLT
3	1	900128	3/8UNC X 3/4 HEX BOLT
4	2	914004	3/8UNC HEX STOVER NUT
5	2	920002	3/8 SAE FLAT WASHER
6	1	343073	MIRROR MT TUBE WLD
7	1	343077	RH MIRROR BRACE TUBE BRKT WLD

LH MIRROR ASSEMBLY

DET. QTY PART NO. DESCRIPTION

1	1	470316	MIRROR HEAD W/MTG HARDWARE
2	1	900129	3/8UNC X 1" HEX BOLT
3	1	900128	3/8UNC X 3/4 HEX BOLT
4	2	914004	3/8UNC HEX STOVER NUT
5	2	920002	3/8 SAE FLAT WASHER
6	1	343073	MIRROR MT TUBE WLD
7	1	343078	LH MIRROR BRACE TUBE BRKT WLD

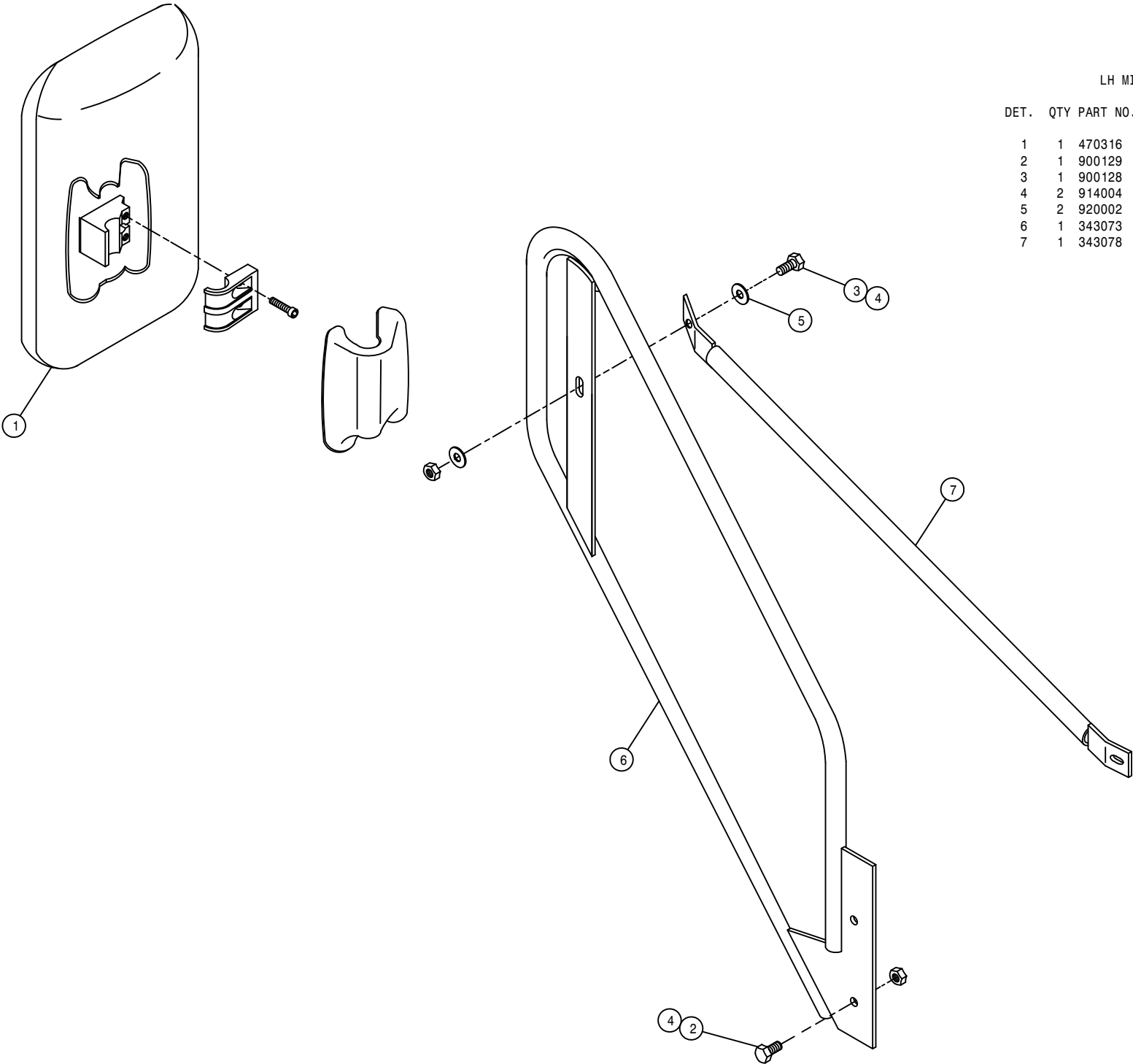

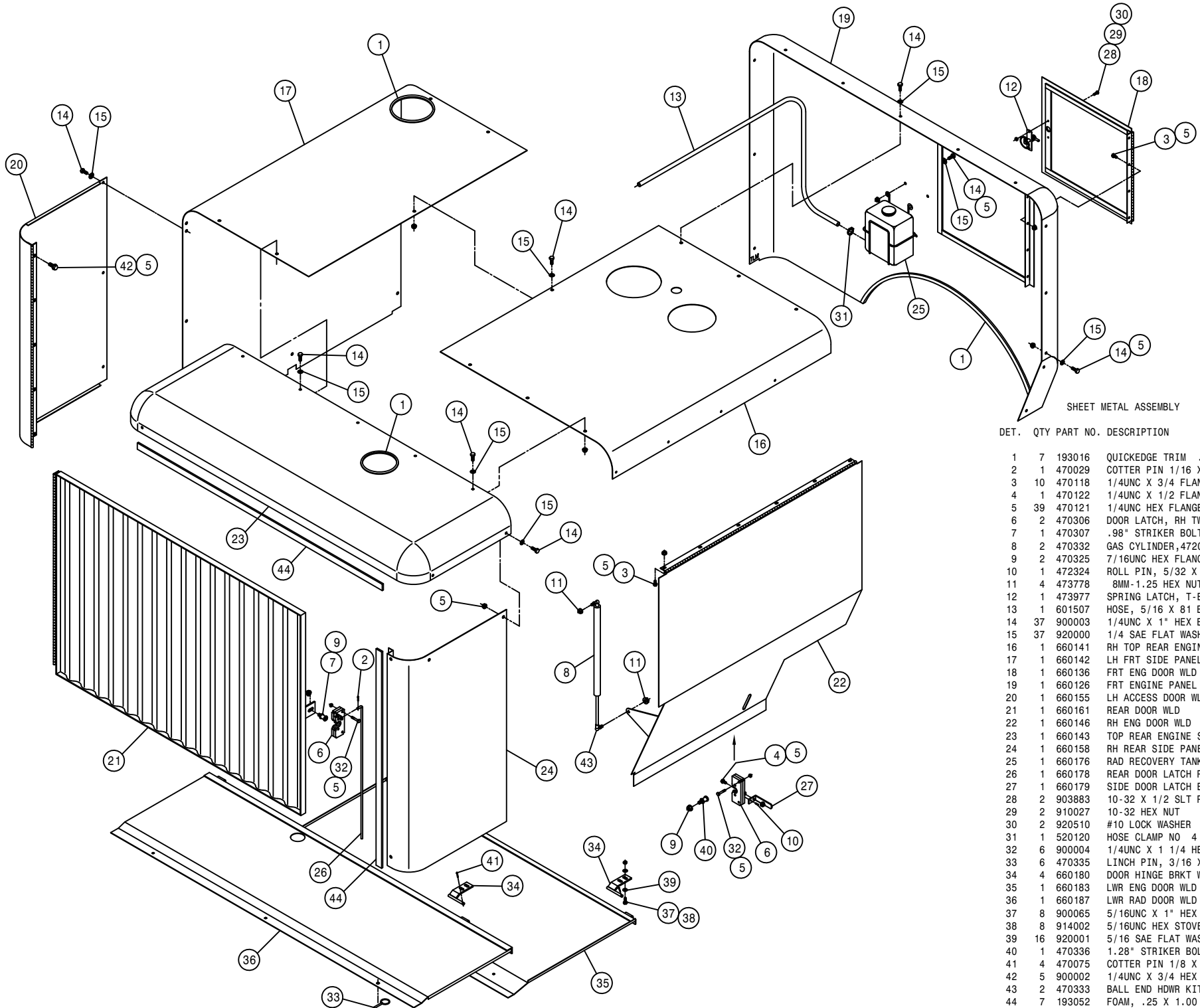

SHEET METAL ASSEMBLY

DET.	QTY	PART NO.	DESCRIPTION
1	7	193016	QUICKEDGE TRIM .060 TO .170
2	1	470029	COTTER PIN 1/16 X 1/2
3	10	470118	1/4UNC X 3/4 FLANGE HEX BOLT
4	1	470122	1/4UNC X 1/2 FLANGE HEX BOLT
5	39	470121	1/4UNC HEX FLANGE LOCK NUT
6	2	470306	DOOR LATCH, RH TWO-ROTOR
7	1	470307	.98" STRIKER BOLT FOR 470306
8	2	470332	GAS CYLINDER,4720 9.23 STROKE
9	2	470325	7/16UNC HEX FLANGE LOCK NUT
10	1	472324	ROLL PIN, 5/32 X 1/2 LG
11	4	473778	8MM-1.25 HEX NUT
12	1	473977	SPRING LATCH, T-BAR
13	1	601507	HOSE, 5/16 X 81 EPDM
14	37	900003	1/4UNC X 1" HEX BOLT
15	37	920000	1/4 SAE FLAT WASHER
16	1	660141	RH TOP REAR ENGINE SHIELD
17	1	660142	LH FRT SIDE PANEL
18	1	660136	FRT ENG DOOR WLD
19	1	660126	FRT ENGINE PANEL WLD
20	1	660155	LH ACCESS DOOR WLD
21	1	660161	REAR DOOR WLD
22	1	660146	RH ENG DOOR WLD
23	1	660143	TOP REAR ENGINE SHIELD WLD
24	1	660158	RH REAR SIDE PANEL WLD
25	1	660176	RAD RECOVERY TANK AND MTG WLD
26	1	660178	REAR DOOR LATCH ROD
27	1	660179	SIDE DOOR LATCH EXT
28	2	903883	10-32 X 1/2 SLT RDHD MACH SCR
29	2	910027	10-32 HEX NUT
30	2	920510	#10 LOCK WASHER
31	1	520120	HOSE CLAMP NO 4 STAINLESS
32	6	900004	1/4UNC X 1 1/4 HEX BOLT
33	6	470335	LINCH PIN, 3/16 X 1 1/4 GRIP
34	4	660180	DOOR HINGE BRKT WLD STS12 2001
35	1	660183	LWR ENG DOOR WLD STS12 2001
36	1	660187	LWR RAD DOOR WLD STS12 2001
37	8	900065	5/16UNC X 1" HEX BOLT
38	8	914002	5/16UNC HEX STOVER NUT
39	16	920001	5/16 SAE FLAT WASHER
40	1	470336	1.28" STRIKER BOLT FOR 470306
41	4	470075	COTTER PIN 1/8 X 3/4
42	5	900002	1/4UNC X 3/4 HEX BOLT
43	2	470333	BALL END HDWR KIT FOR 470332
44	7	193052	FOAM, .25 X 1.00 X 50 FT W/PSA

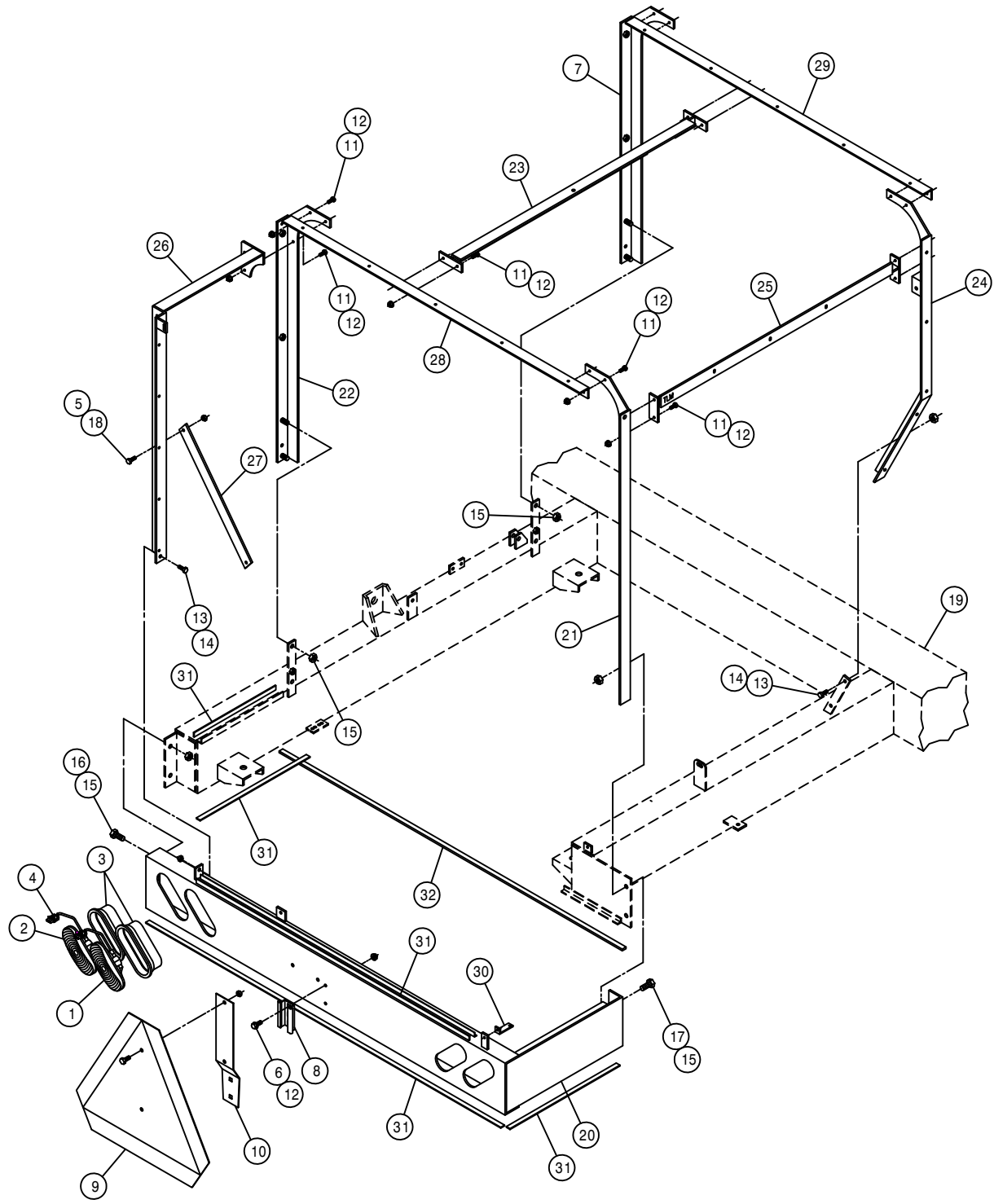

SHEET METAL FRAME ASSEMBLY

DET.	QTY	PART NO.	DESCRIPTION
	1	2	291694 RED LAMP, 6 1/2" OVAL 12.8V
	2	2	291695 YELLOW LAMP, 6 1/2" OVAL 12.8V
	3	4	291697 RUBBER MT FOR 6 1/2" OVAL LAMP
	4	4	293515 3-WIRE PIGTAIL ASSY
	5	2	914002 5/16UNC HEX STOVER NUT
	6	2	470118 1/4UNC X 3/4 FLANGE HEX BOLT
	7	1	660101 LH FRT POST WLD
	8	1	472251 MTG SOCKET
	9	1	472249 SLOW MOVING VEHICLE SIGN
	10	1	472250 SPADE MTG BRKT
	11	16	900003 1/4UNC X 1" HEX BOLT
	12	18	470121 1/4UNC HEX FLANGE LOCK NUT
	13	3	900129 3/8UNC X 1" HEX BOLT
	14	3	914004 3/8UNC HEX STOVER NUT
	15	8	914008 1/2UNC HEX STOVER NUT
	16	2	900264 1/2UNC X 1 1/4 HEX BOLT
	17	2	900265 1/2UNC X 1 1/2 HEX BOLT
	18	2	900065 5/16UNC X 1" HEX BOLT
	19	1	361500 MAINFRAME WLD STS12
	20	1	361585 BUMPER WLD
	21	1	660106 RH REAR SUPPORT WLD
	22	1	660107 LH CNTR POST WLD
	23	1	660114 TOP CNTR BRACE ANGLE WLD
	24	1	660100 RH FRT DOOR SUPP WLD
	25	1	660117 RH TOP DOOR SUPPORT WLD
	26	1	660120 LH REAR SUPPORT POST
	27	1	660125 ENG COMPARTMENT BRACE
	28	1	660112 REAR CNTR SUPPORT WLD
	29	1	660110 FRONT CNTR SUPPORT WLD
	30	1	660190 REAR DOOR LATCH ROD GUIDE 01
	31	14	193052 FOAM, .25 X 1.00 X 50 FT W/PSA
	32	5	193053 FOAM, .50 X 1.00 X 50 FT W/PSA

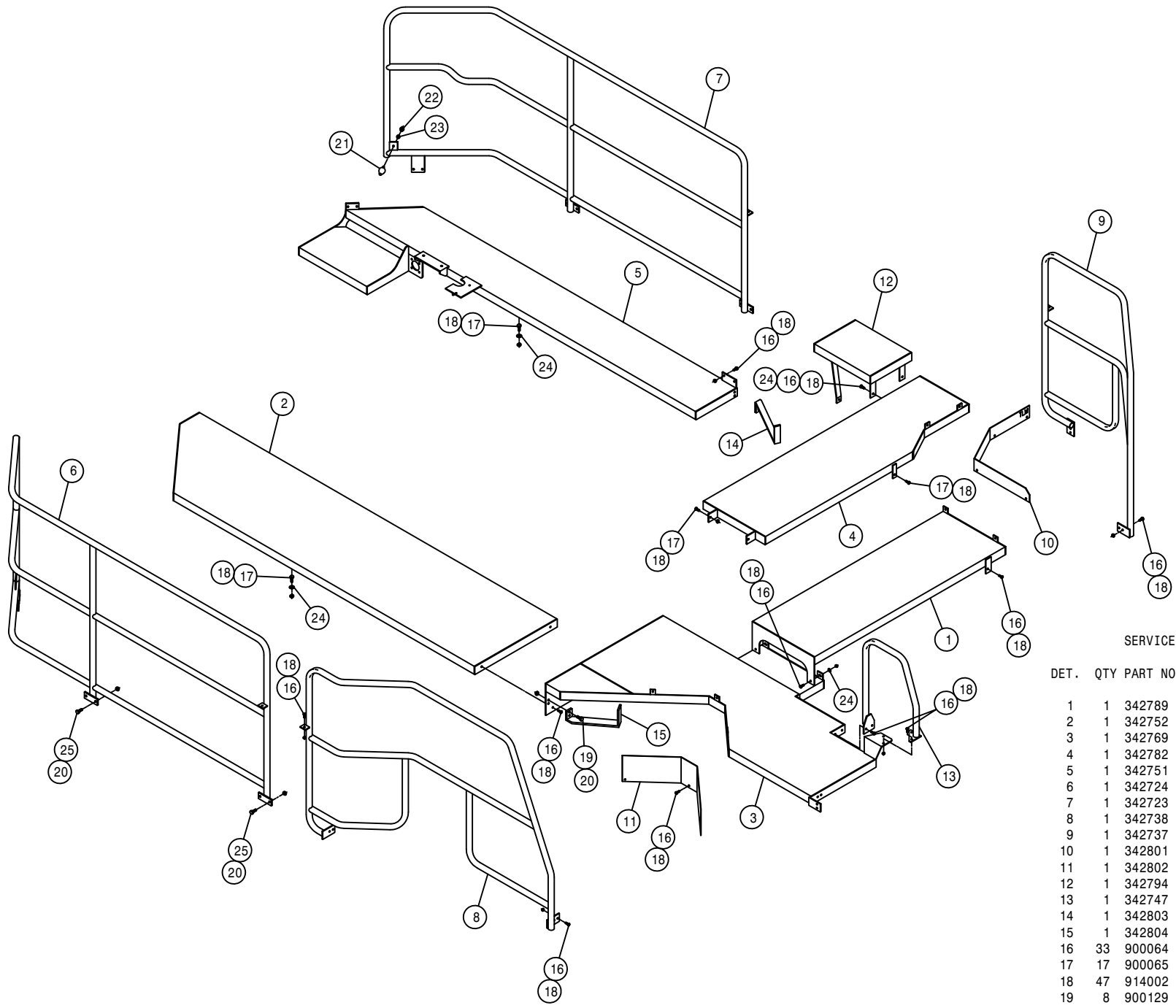

SERVICE PLATFORM ASSEMBLY

DET.	QTY	PART NO.	DESCRIPTION
1	1	342789	CENTER SERV PLATFORM WLD
2	1	342752	LH SERV PLATFORM WLD
3	1	342769	LH REAR SERV PLATFORM WLD
4	1	342782	CENTER FRT PLATFORM WLD
5	1	342751	RH SERV PLATFORM WLD
6	1	342724	LH FRT HANDRAIL WLD
7	1	342723	RH FRT HANDRAIL WLD
8	1	342738	LH REAR HANDRAIL WLD
9	1	342737	RH REAR HANDRAIL WLD
10	1	342801	RH SERV PLATFORM SHIELD
11	1	342802	LH SERV PLATFORM SHIELD
12	1	342794	RH STEP WLD
13	1	342747	RH HANDRAIL WLD, LH PLATFORM
14	1	342803	RH REAR LEG HOSE SUPPORT
15	1	342804	LH REAR LEG HOSE SUPPORT
16	33	900064	5/16UNC X 3/4 HEX BOLT
17	17	900065	5/16UNC X 1" HEX BOLT
18	47	914002	5/16UNC HEX STOVER NUT
19	8	900129	3/8UNC X 1" HEX BOLT
20	16	914004	3/8UNC HEX STOVER NUT
21	2	470314	RUBBER BUMPER,BULLET W/3/8-24S
22	2	910005	3/8UNF HEX NUT
23	2	920502	3/8 LOCK WASHER
24	16	920001	5/16 SAE FLAT WASHER
25	8	900130	3/8UNC X 1 1/4 HEX BOLT

1200 GALLON SS TANK ASSEMBLY

DET. QTY PART NO. DESCRIPTION

1	1	500013	1" NPT HEX PIPE NIPPLE, POLY
2	1	500014	1" NPT-90 ST EL, POLY
3	1	500034	1 1/2 NPT-90 ST EL, POLY
4	1	500036	1 1/2" X 1" NPT REDU BUSH, POLY
5	1	500063	1" NPT PIPE PLUG, POLY
6	2	500074	1" NPT-1" HOSE BARB, POLY
7	1	500075	1" NPT PIPE TEE, POLY
8	1	500104	1/4 NPT-90-1/4 HOSE BARB, POLY
9	3	500194	2" FP FLANGE CLAMP, S.S.
10	3	500195	2" FP FLANGE GASKET EPDM
11	7	500208	3" FLANGE CLAMP, S.S.
12	7	500209	3" FLANGE GASKET EPDM
13	1	505225	1"-1/4" NPT REDU BUSH, POLY
14	1	507103	PIPE CAP, 2.00" NPT S.S.
15	1	507725	REDU BUSH 2 X 1 1/2 S.S.
16	1	507726	PIPE ELBOW, 1" NPT 90D S.S.
17	1	507727	STREET ELBOW, 1 1/2" 90D S.S.
18	1	520067	HOSE CLAMP NO 28 STAINLESS
19	1	520069	HOSE CLAMP NO 6 STAINLESS
20	5	520090	HOSE CLAMP NO 16 STAINLESS
21	1	601471	HOSE, 1" X 60 CLEAR VINYL
22	1	716100	1" HOSE BARB X 1" MNPT S.S.
23	1	716106	1 1/2" HOSE BARB-1 1/2" MNPT S.S.
24	1	763550	1200 GAL SS TANK
25	1	500196	2" FP FLANGE-2" HOSE BARB POLY
26	1	500219	2" FP FLANGE-90-2" FP FLANGE LBO
27	1	696148	BALL VLV, 2" FP FLANGE
28	2	500213	3" FLANGE-90-3" FLANGE LBO POLY
29	3	500210	3" FLANGE-3" HOSE BARB POLY
30	1	696149	BALL VLV, 3" FLANGE
31	1	500217	3" FLANGE TEE POLY
32	1	500211	3" FLANGE-90-3" HOSE BARB POLY
33	6	520145	356 T-BOLT HOSE CLAMP SS
34	1	520141	2.31/2.62 T-BOLT HOSE CLAMP SS
35	2	470321	BALER BELT, 4.00 X 67.00 2-PLY
36	4	482016	SPRING, 1.40 X 3.00 COMPRN
37	8	920006	3/4 SAE FLAT WASHER
38	4	900416	3/4 UNC X 6 1/2 HEX BOLT
39	4	914012	3/4 UNC HEX STOVER NUT
40	1	690731	SOLU TUBE, 3.00 S.S. SIDE FILL
41	1	601503	HOSE, 3 X 8 POLY HELIX EPDM
42	1	601504	HOSE, 3 X 22 POLY HELIX EPDM
43	1	601505	HOSE, 3 X 40 POLY HELIX EPDM
44	1	601506	HOSE, 3 X 74 POLY HELIX EPDM
45	1	601520	HOSE, 2 X 64 2F-1W EPDM
46	1	601508	HOSE, 3 X 64 POLY HELIX EPDM
47	1	601490	HOSE, 1/4 X 95 1 BR BLK EPDM
48	1	601500	HOSE, 1 1/2 X 43 2BR BLK EPDM
49	1	601496	HOSE, 1 X 120 1BR BLK EPDM
50	1	601494	HOSE, 1 X 108 1BR BLK EPDM
51	1	601495	HOSE, 1 X 110 1BR BLK EPDM
52	2	900064	5/16 UNC X 3/4 HEX BOLT
53	2	914002	5/16 UNC HEX STOVER NUT
54	1	763561	LID ASSY FOR 763550 TANK
55	1	763562	10" FILL LID SEAL FOR 763550
56	1	763563	16" MANHOLE SEAL FOR 763550

NOTE: ITEMS (*) ARE USED WITH THE SIDE FILL OPTION

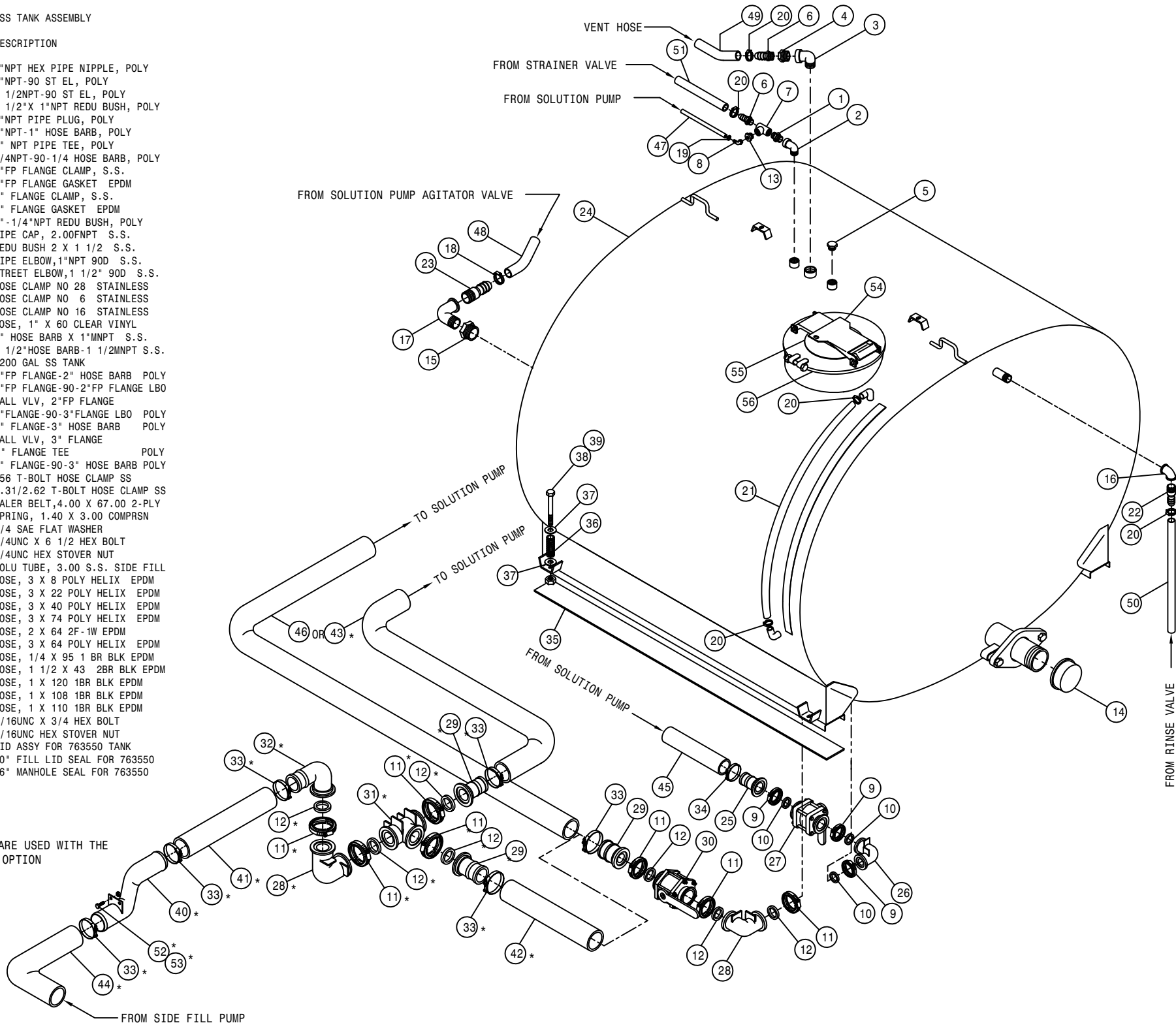

55

252055

RINSE TANK ASSEMBLY

DET. QTY PART NO. DESCRIPTION

1	1	500024	1"NPT-90-1"HOSE BARB, POLY
2	2	500157	1" FLANGE GASKET EPDM
3	2	500159	1" FLANGE CLAMP, S.S.
4	1	500163	1" FLANGE-1" MNPT ADPTR POLY
5	1	500173	1" FLANGE-90-1" HOSE BARB POLY
6	1	507023	SS CLOSE PIPE NIPPLE, 1.00MNPT
7	1	690660	LINE "T" STRAINER, 1" FLANGE
8	1	690669	100 MESH SCREEN FOR 690660
9	1	696004	BALL VLV,1.00NP 3WAY-SIDE POLY
10	3	520090	HOSE CLAMP NO 16 STAINLESS
11	3	520070	HOSE CLAMP NO 8 STAINLESS
12	2	500074	1"NPT-1" HOSE BARB, POLY
13	1	505114	SS PIPE ST EL 90DEG 1.00NPT
14	1	500041	3/4NPT-90-1/2"HOSE BARB, POLY
15	1	505214	1"-3/4"NPT REDU BUSH, POLY
16	1	763552	100 GAL SS TANK
17	2	763554	SS RINSE/SOLU TANK PAD
18	1	601488	HOSE, 1/2 X 17 CLEAR VINYL
19	1	601165	HOSE, 1/2 X 144 1BR BLK EPDM
20	1	601492	HOSE, 1 X 37 1BR BLK EPDM
21	1	601179	HOSE, 1 X 26 1BR BLK EPDM
22	4	900265	1/2UNC X 1 1/2 HEX BOLT
23	4	914008	1/2UNC HEX STOVER NUT
24	8	920004	1/2 SAE FLAT WASHER
25	1	690801	STRAINER GASKET FOR 690660
26	1	763564	LID ASSY FOR 763552 TANK
27	1	763565	FILL LID SEAL FOR 763552 TANK

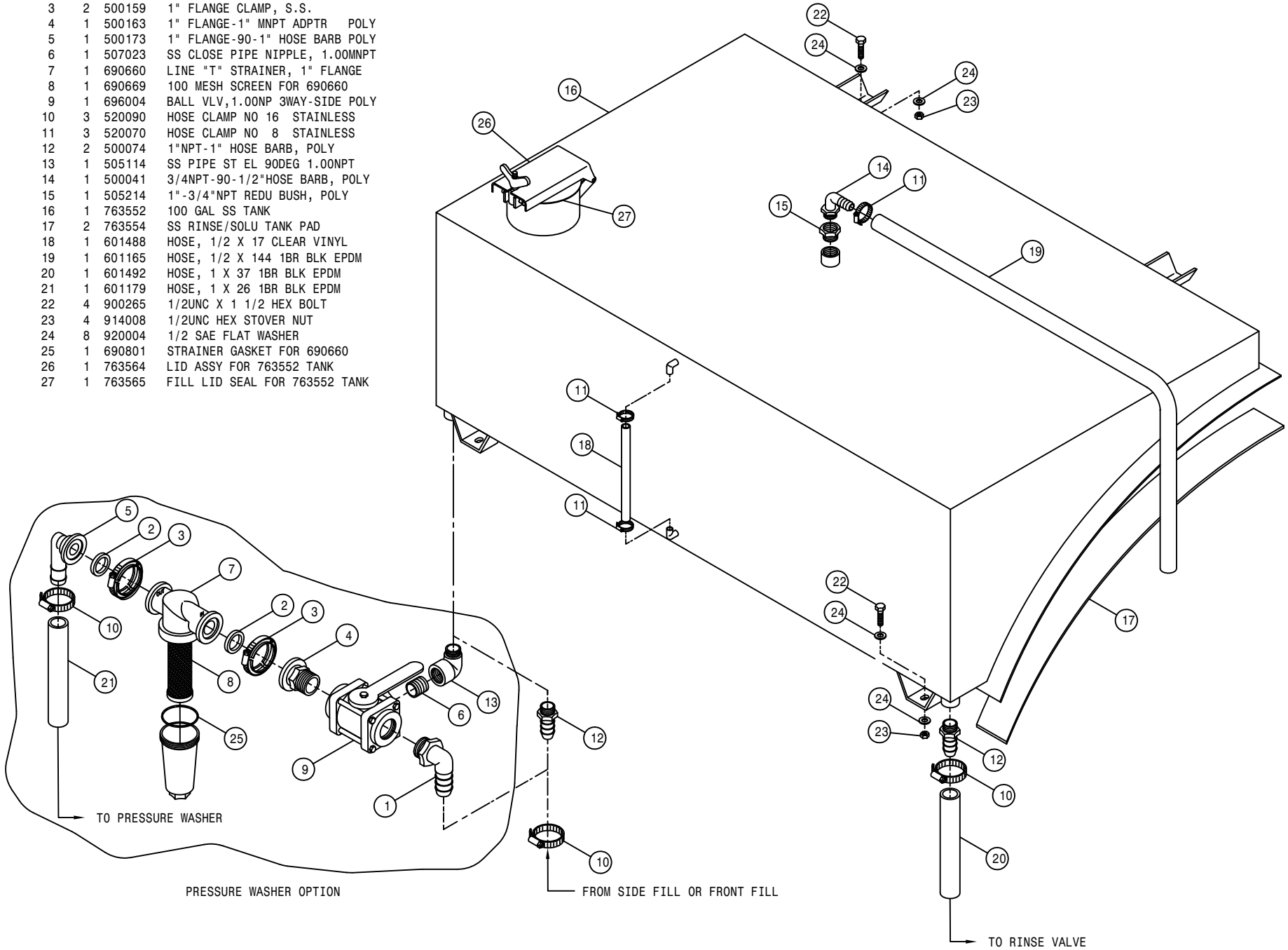

PRESSURE WASHER OPTION

POLY RINSE TANK ASSEMBLY

DET. QTY PART NO. DESCRIPTION

1	3	500024	1"NPT-90-1"HOSE BARB, POLY
2	2	500063	1"NPT PIPE PLUG, POLY
3	1	763553	100 GAL POLY TANK
4	1	763590	POLY RINSE TANK MT WLD STS12
5	1	763594	POLY RINSE TANK MT PAD STS12
6	2	763595	POLY RINSE TNK STRAP ASSY STS
7	2	900392	1/2UNC X 1 1/2 SOCKET CAP SCR
8	4	914008	1/2UNC HEX STOVER NUT
9	2	920004	1/2 SAE FLAT WASHER
10	2	500157	1" FLANGE GASKET EPDM
11	2	500159	1" FLANGE CLAMP, S.S.
12	1	500163	1" FLANGE-1" MNPT ADPTR POLY
13	1	500173	1" FLANGE-90-1" HOSE BARB POLY
14	1	505198	SS PIPE NIPPLE 1.00NPT-3.00
15	1	690660	LINE "T" STRAINER, 1" FLANGE
16	1	690669	100 MESH SCREEN FOR 690660
17	1	696004	BALL VLV,1.00NP 3WAY-SIDE POLY
18	3	520090	HOSE CLAMP NO 16 STAINLESS
19	1	601179	HOSE, 1 X 26 1BR BLK EPDM
20	1	601535	HOSE, 1 X 46 1BR BLK EDPM

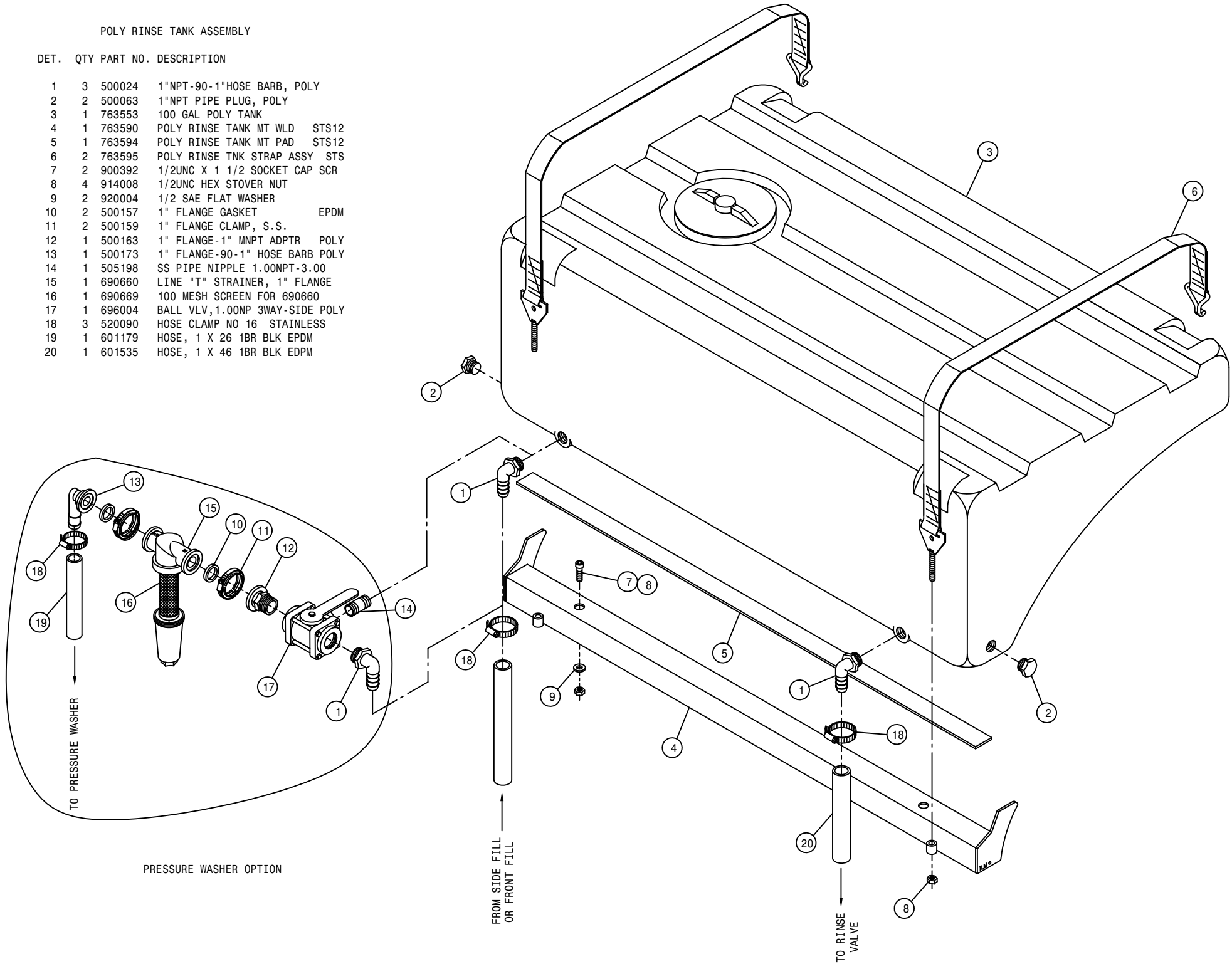

PRESSURE WASHER OPTION

SOLUTION PUMP ASSEMBLY

DET. QTY PART NO. DESCRIPTION

DET.	QTY	PART NO.	DESCRIPTION
1	1	500024	1"NPT-90-1"HOSE BARB, POLY
2	1	500153	2" FLANGE-90-1 1/2 HBARB POLY
3	1	500154	2" FLANGE-2" HOSE BARB POLY
4	9	500158	1 1/2" GASKET FOR 2" FLANGE
5	9	500160	2" FLANGE CLAMP, S.S.
6	2	500180	2"FLANGE-90-2"FLANGE LBO POLY
7	1	500189	2" FLANGE-90-1" HOSE BARB POLY
8	1	500191	2" FLANGE-90-2" HOSE BARB POLY
9	10	500194	2"FP FLANGE CLAMP, S.S.
10	10	500195	2"FP FLANGE GASKET EPDM
11	5	500199	2"FP FLANGE-2"FLANGE REDU POLY
12	1	500205	2"FP FLANGE-2"MNPT ADPTR S.S.
13	3	500207	2"FP FLANGE TEE POLY
14	4	500208	3" FLANGE CLAMP, S.S.
15	4	500209	3" FLANGE GASKET EPDM
16	2	500210	3" FLANGE-3" HOSE BARB POLY
17	1	500212	3"FLANGE-2"FP FLANGE REDU POLY
18	1	500214	3"FP FLANGE CROSS
19	1	500215	3" FLANGE CAP PLUG POLY
20	1	500216	3"FLANGE PLUG W/1"FNPT POLY
21	1	500218	2"FLANGE-1 1/2"MNPT ADPTR S.S.
22	2	500219	2"FP FLANGE-90-2"FP FLANGE LBO
23	2	520052	HOSE CLAMP NO 52 STAINLESS
24	2	520090	HOSE CLAMP NO 16 STAINLESS
25	2	520141	2.31/2.62 T-BOLT HOSE CLAMP SS
26	2	520145	356 T-BOLT HOSE CLAMP SS
27	2	618273	1 1/16MJIC-1/2MNPT ADPTR
28	1	690670	HYPRO PUMP, 9305C-HM3CB
29	1	696176	ELECT BALL VLV,2"FLANGE BANJO
30	1	696179	ELECT BALL VLV,2"FLANGE 4-5SEC
31	1	690682	SOLU PUMP TEE FTG SUPP BRKT
32	1	311511	1.00 'U' HOSE, DAYCO 70564
33	1	500103	1/8NPT-90-1/4 HOSE BARB,NYLON
34	1	520069	HOSE CLAMP NO 6 STAINLESS
35	1	520067	HOSE CLAMP NO 28 STAINLESS
36	2	914004	3/8UNC HEX STOVER NUT
37	2	900131	3/8UNC X 1 1/2 HEX BOLT
38	1	690675	HYD MOTOR, SOLU PUMP 690670

58

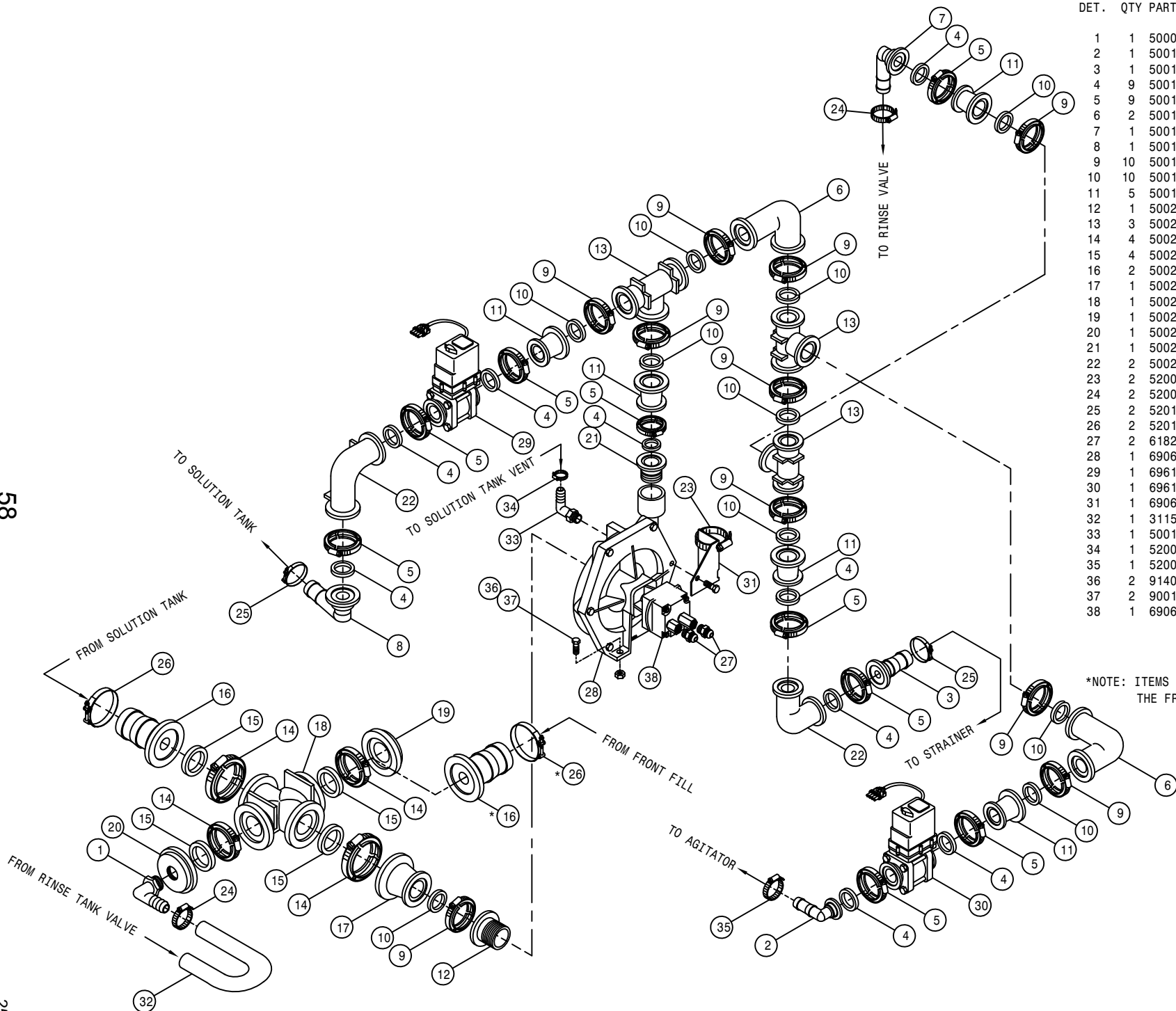

*NOTE: ITEMS 16 & 26 ARE USED WITH THE FRONT FILL OPTION.

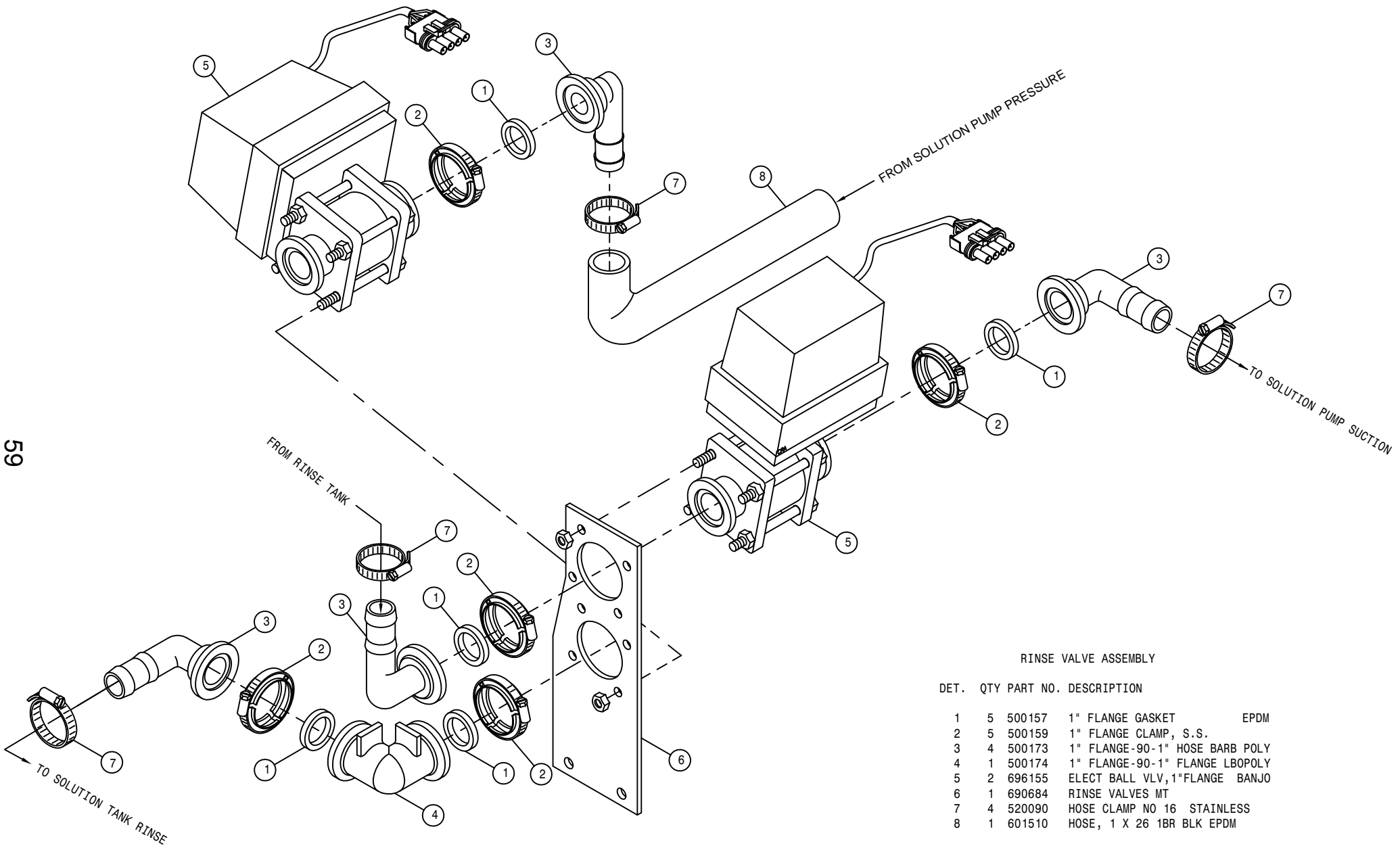

RINSE VALVE ASSEMBLY

DET. QTY PART NO. DESCRIPTION

DET.	QTY	PART NO.	DESCRIPTION	
1	5	500157	1" FLANGE GASKET	EPDM
2	5	500159	1" FLANGE CLAMP, S.S.	
3	4	500173	1" FLANGE-90-1" HOSE BARB POLY	
4	1	500174	1" FLANGE-90-1" FLANGE LBOPOLY	
5	2	696155	ELECT BALL VLV, 1" FLANGE	BANJO
6	1	690684	RINSE VALVES MT	
7	4	520090	HOSE CLAMP NO 16	STAINLESS
8	1	601510	HOSE, 1 X 26 1BR	BLK EPDM

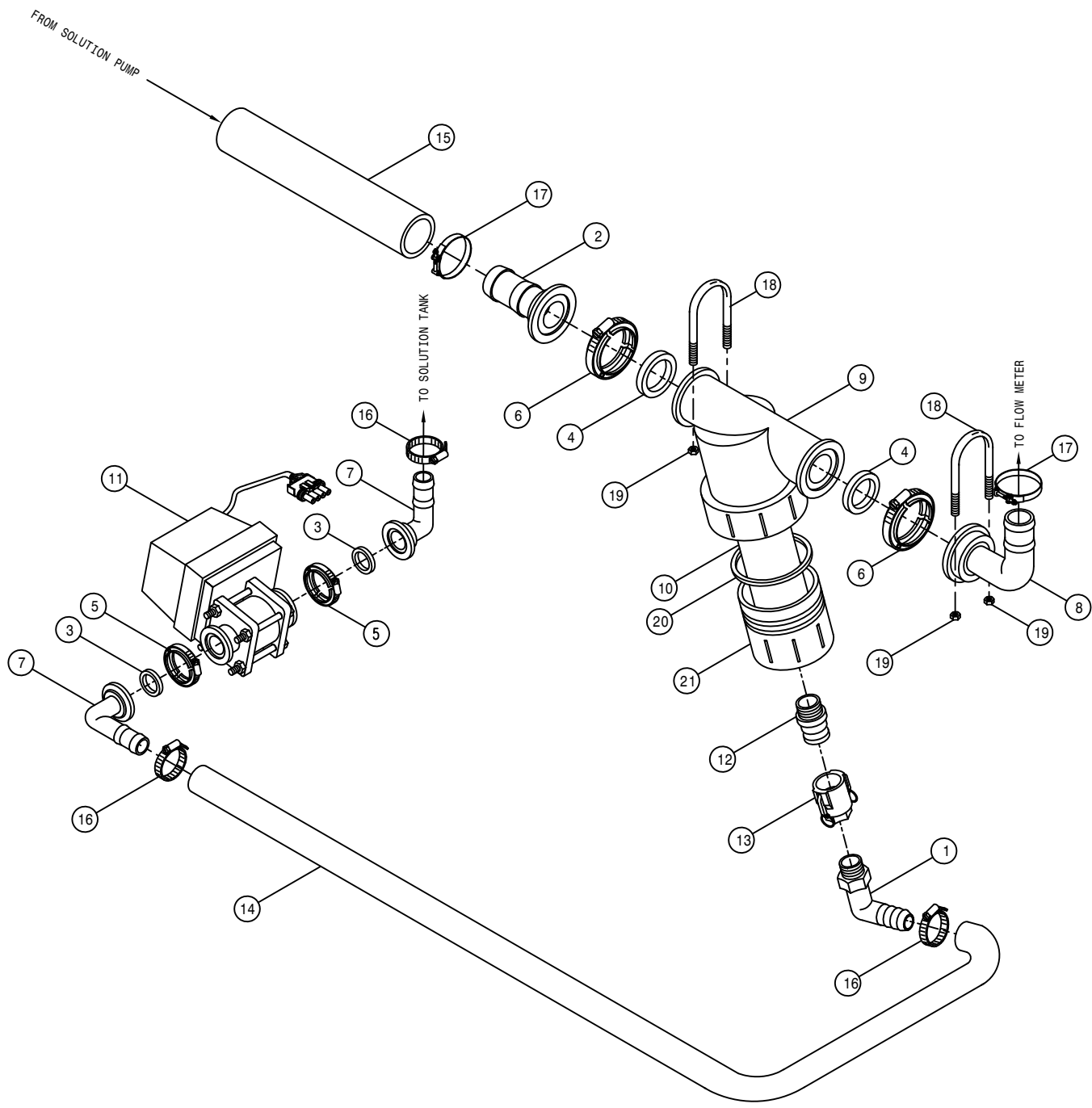

LINE STRAINER AND ELECTRIC VALVE ASSEMBLY

DET.	QTY	PART NO.	DESCRIPTION
	1	500024	1"NPT-90-1"HOSE BARB, POLY
	2	500154	2" FLANGE-2" HOSE BARB POLY
	3	500157	1" FLANGE GASKET EPDM
	4	500158	1 1/2" GASKET FOR 2" FLANGE
	5	500159	1" FLANGE CLAMP, S.S.
	6	500160	2" FLANGE CLAMP, S.S.
	7	500173	1" FLANGE-90-1" HOSE BARB POLY
	8	500191	2" FLANGE-90-2" HOSE BARB POLY
	9	690628	LINE "Y" STRAINER, 2" FLANGE
	10	690629	50 MESH SCREEN FOR 690628
	11	696155	ELECT BALL VLV,1"FLANGE BANJO
	12	696216	1.00FNPT-FEMALE COUPLER POLY
	13	696218	1.00MNPT-MALE COUPLER POLY
	14	601493	HOSE, 1 X 66 1BR BLK EPDM
	15	601501	HOSE, 2 X 27 2F-1W EPDM
	16	520090	HOSE CLAMP NO 16 STAINLESS
	17	520141	2.31/2.62 T-BOLT HOSE CLAMP SS
	18	473974	.31UNC-2.56ID-3.5 U-BOLT SS
	19	914002	5/16UNC HEX STOVER NUT
	20	690630	GASKET FOR 690628
	21	690631	END CAP FOR 690628

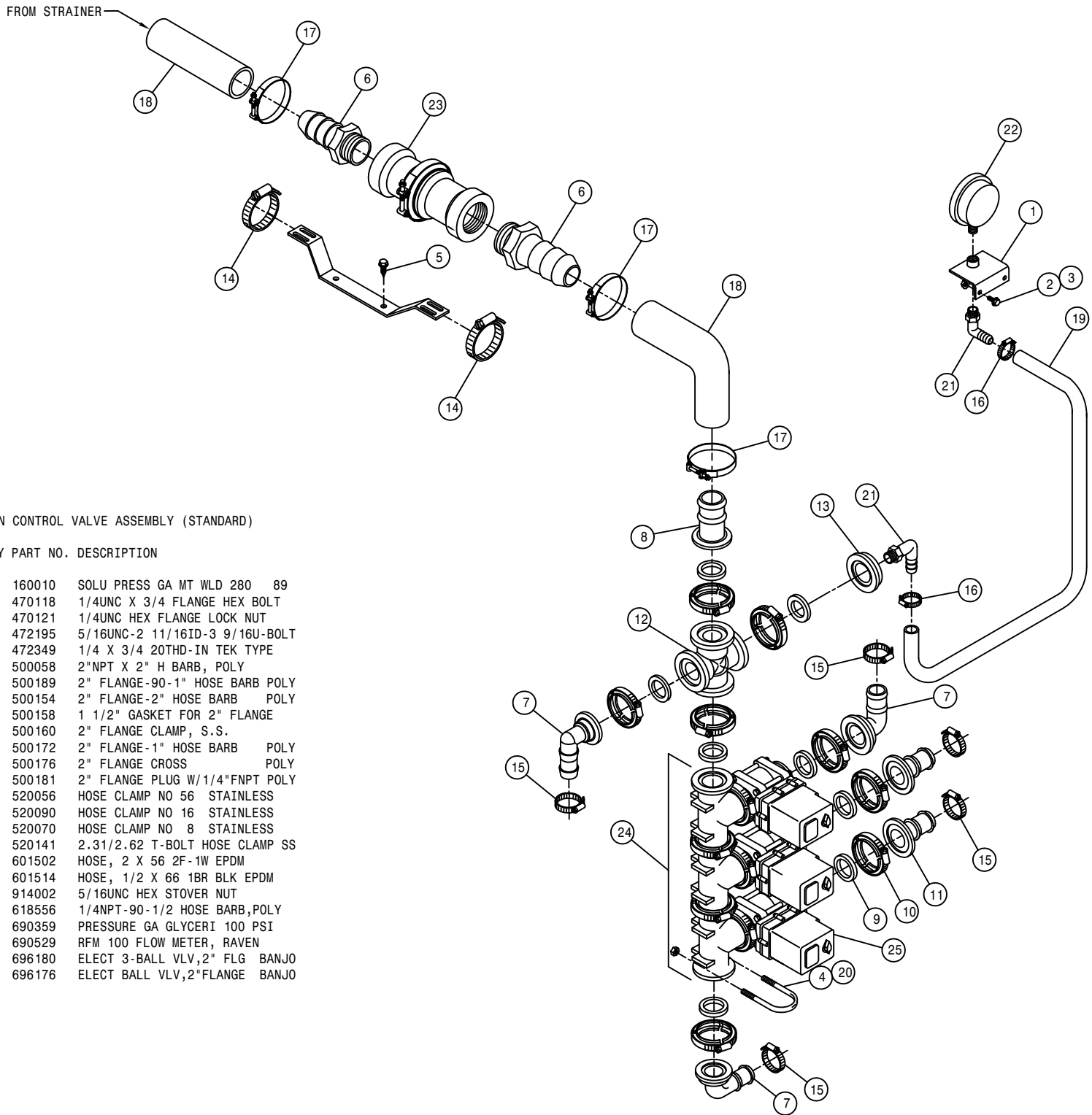

SOLUTION CONTROL VALVE ASSEMBLY (STANDARD)

DET. QTY PART NO. DESCRIPTION

1	1	160010	SOLU PRESS GA MT WLD 280 89
2	2	470118	1/4UNC X 3/4 FLANGE HEX BOLT
3	2	470121	1/4UNC HEX FLANGE LOCK NUT
4	2	472195	5/16UNC-2 11/16ID-3 9/16U-BOLT
5	2	472349	1/4 X 3/4 20THD-IN TEK TYPE
6	2	500058	2"NPT X 2" H BARB, POLY
7	3	500189	2" FLANGE-90-1" HOSE BARB POLY
8	1	500154	2" FLANGE-2" HOSE BARB POLY
9	8	500158	1 1/2" GASKET FOR 2" FLANGE
10	8	500160	2" FLANGE CLAMP, S.S.
11	2	500172	2" FLANGE-1" HOSE BARB POLY
12	1	500176	2" FLANGE CROSS POLY
13	1	500181	2" FLANGE PLUG W/1/4"FNPT POLY
14	2	520056	HOSE CLAMP NO 56 STAINLESS
15	5	520090	HOSE CLAMP NO 16 STAINLESS
16	2	520070	HOSE CLAMP NO 8 STAINLESS
17	3	520141	2.31/2.62 T-BOLT HOSE CLAMP SS
18	2	601502	HOSE, 2 X 56 2F-1W EPDM
19	1	601514	HOSE, 1/2 X 66 1BR BLK EPDM
20	4	914002	5/16UNC HEX STOVER NUT
21	2	618556	1/4NPT-90-1/2 HOSE BARB,POLY
22	1	690359	PRESSURE GA GLYCERI 100 PSI
23	1	690529	RFM 100 FLOW METER, RAVEN
24	1	696180	ELECT 3-BALL VLV,2" FLG BANJO
25	3	696176	ELECT BALL VLV,2"FLANGE BANJO

80'-90' SOLUTION VALVE ASSEMBLY (STANDARD)

DET. QTY PART NO. DESCRIPTION

1	2	500158	1 1/2" GASKET FOR 2" FLANGE
2	2	500160	2" FLANGE CLAMP, S.S.
3	2	500172	2" FLANGE-1" HOSE BARB POLY
4	1	690745	2" SOLU VLV MT WLD
5	1	696176	ELECT BALL VLV, 2" FLANGE BANJO
6	1	520067	HOSE CLAMP NO 28 STAINLESS
7	2	520090	HOSE CLAMP NO 16 STAINLESS

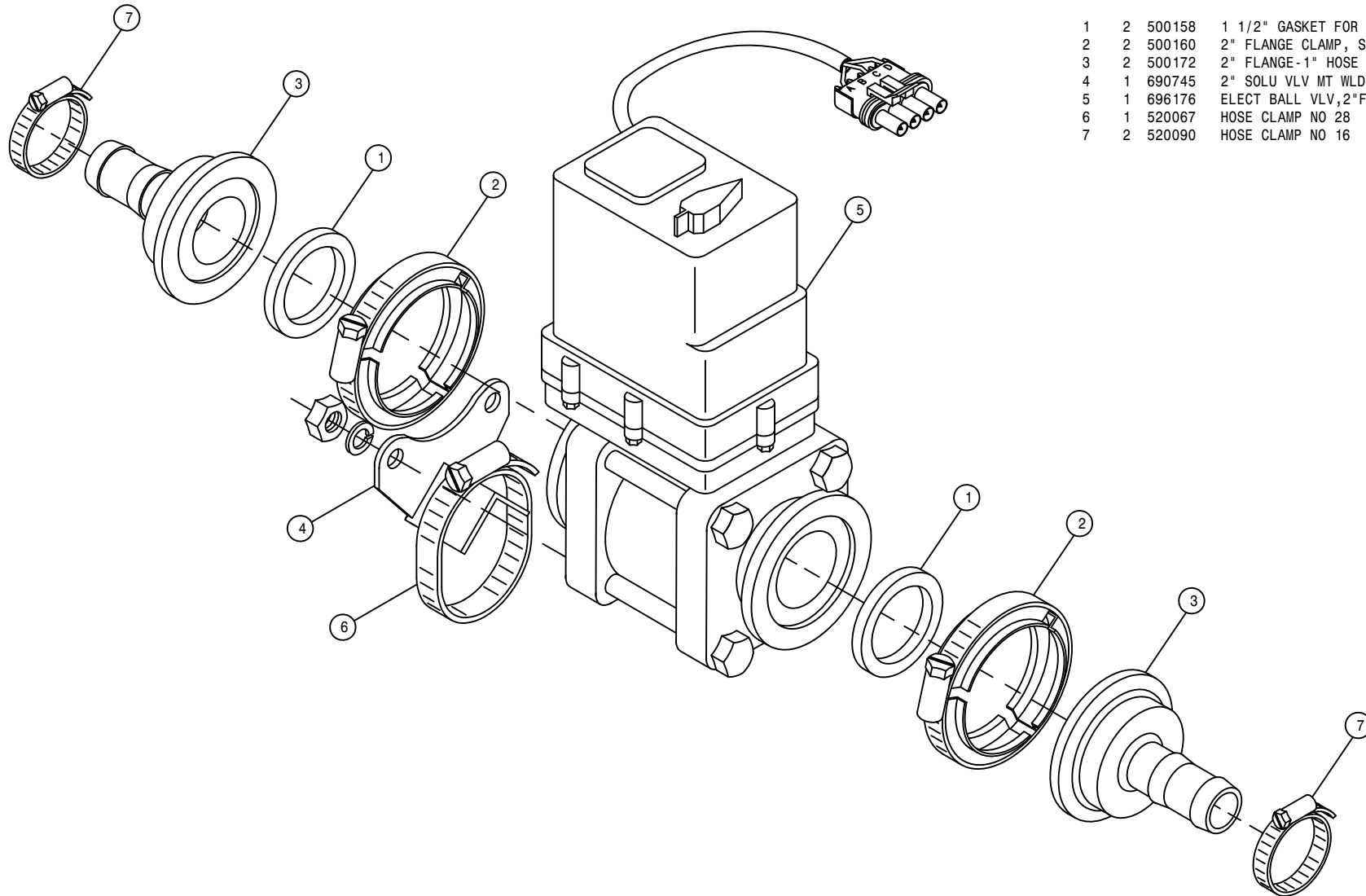

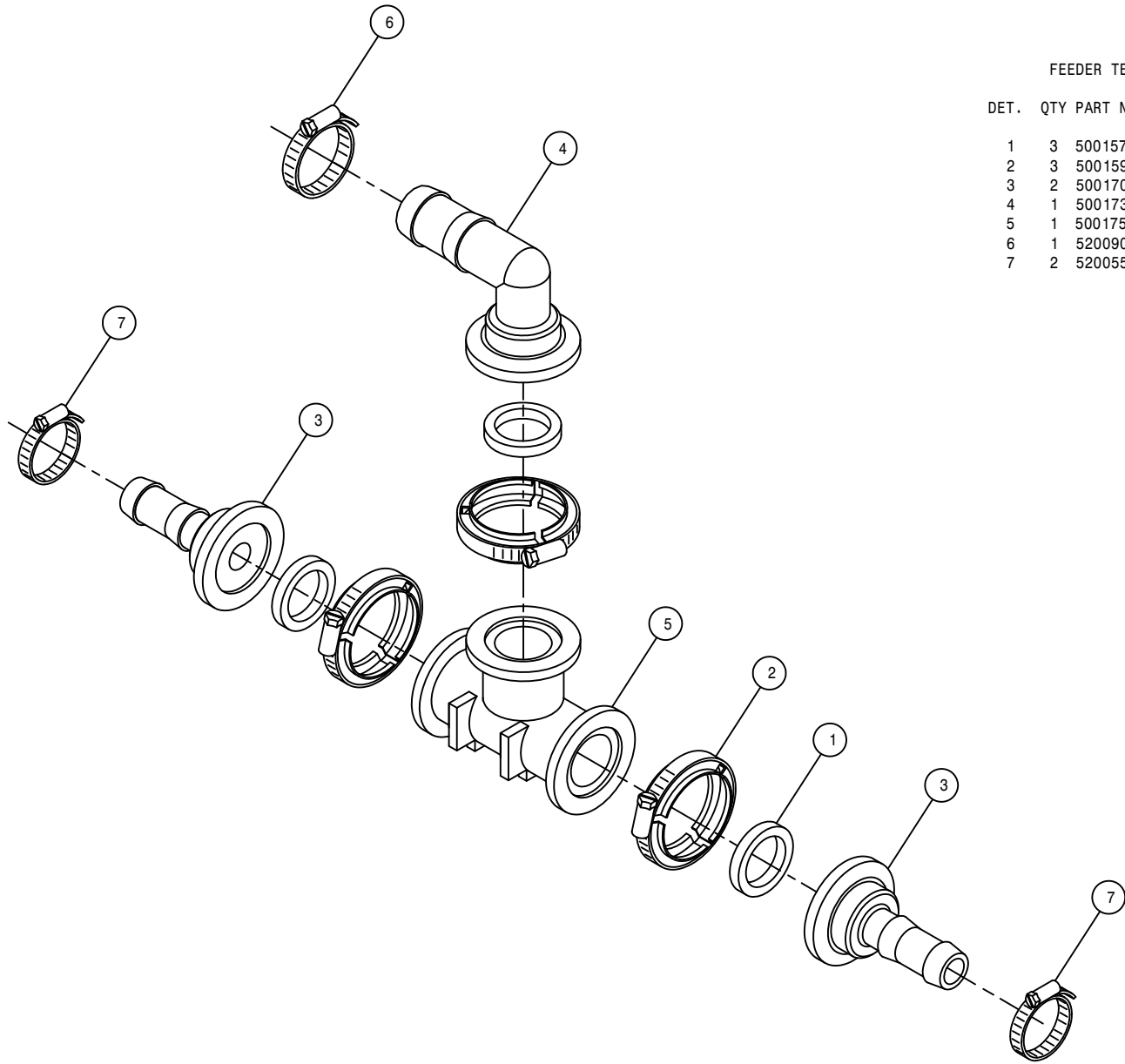

FEEDER TEE ASSEMBLY (STANDARD)

DET.	QTY	PART NO.	DESCRIPTION	
1	3	500157	1" FLANGE GASKET	EPDM
2	3	500159	1" FLANGE CLAMP, S.S.	
3	2	500170	1" FLANGE-3/4" HOSE BARB	POLY
4	1	500173	1" FLANGE-90-1" HOSE BARB	POLY
5	1	500175	1" FLANGE TEE	POLY
6	1	520090	HOSE CLAMP NO 16	STAINLESS
7	2	520055	HOSE CLAMP NO 12	STAINLESS

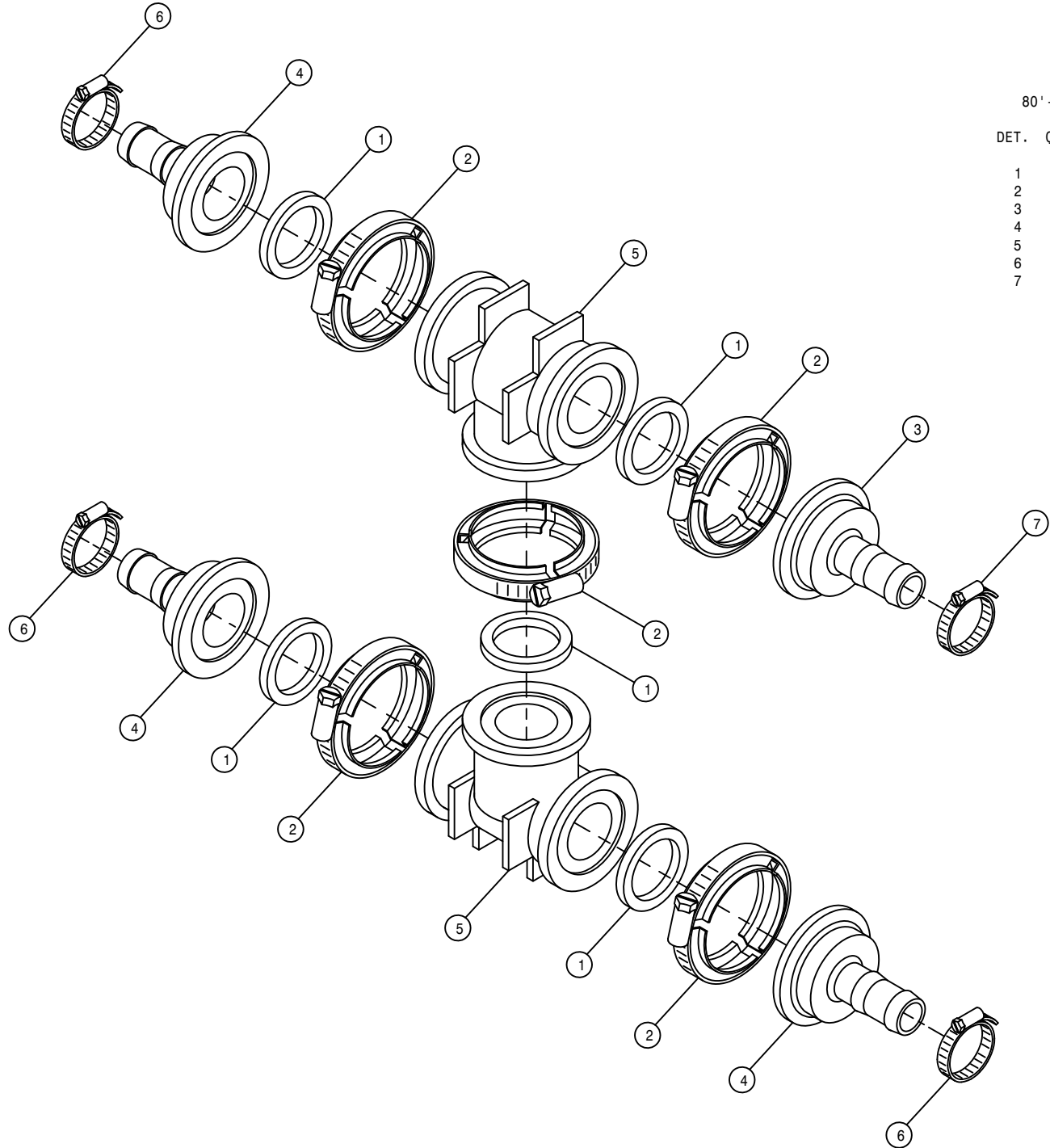

80'-90' FEEDER TEE ASSEMBLY (STANDARD)

DET.	QTY	PART NO.	DESCRIPTION	
1	5	500157	1" FLANGE GASKET	EPDM
2	5	500159	1" FLANGE CLAMP, S.S.	
3	1	500171	1" FLANGE-1" HOSE BARB	POLY
4	3	500170	1" FLANGE-3/4" HOSE BARB	POLY
5	2	500175	1" FLANGE TEE	POLY
6	3	520055	HOSE CLAMP NO 12	STAINLESS
7	1	520090	HOSE CLAMP NO 16	STAINLESS

90' BALL VALVE ASSEMBLY (STANDARD)

DET. QTY PART NO. DESCRIPTION

1	2	500157	1" FLANGE GASKET	EPDM
2	2	500159	1" FLANGE CLAMP, S.S.	
3	2	500170	1" FLANGE-3/4" HOSE BARB	POLY
4	1	701191	1" SOLU VLV MT WLD	
5	1	696147	BALL VLV, 1" FLANGE	
6	1	520085	HOSE CLAMP NO 24	STAINLESS
7	2	520055	HOSE CLAMP NO 12	STAINLESS

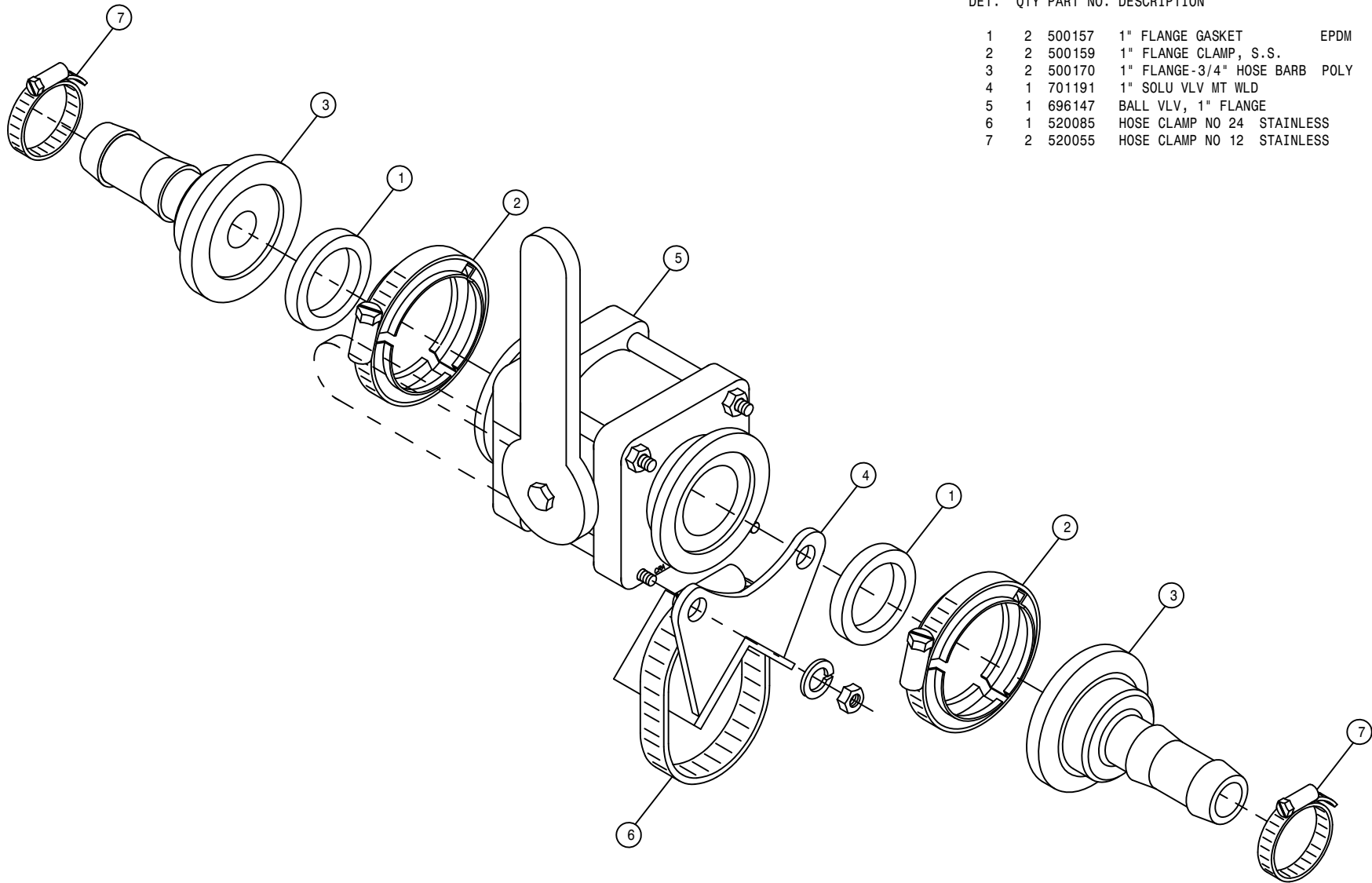

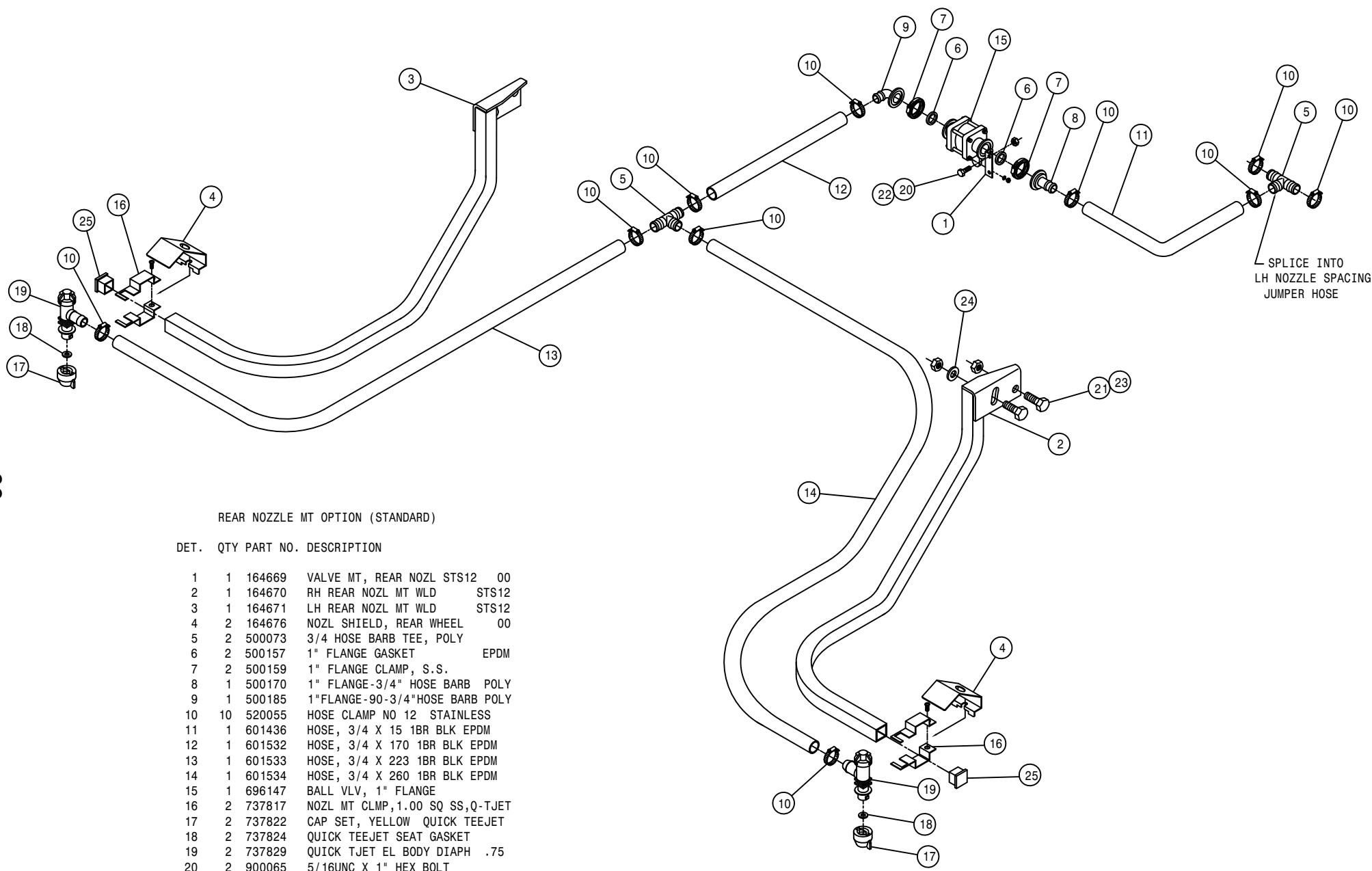

REAR NOZZLE MT OPTION (STANDARD)

DET. QTY PART NO. DESCRIPTION

1	1	164669	VALVE MT, REAR NOZL STS12	00
2	1	164670	RH REAR NOZL MT WLD	STS12
3	1	164671	LH REAR NOZL MT WLD	STS12
4	2	164676	NOZL SHIELD, REAR WHEEL	00
5	2	500073	3/4 HOSE BARB TEE, POLY	
6	2	500157	1" FLANGE GASKET	EPDM
7	2	500159	1" FLANGE CLAMP, S.S.	
8	1	500170	1" FLANGE-3/4" HOSE BARB	POLY
9	1	500185	1"FLANGE-90-3/4"HOSE BARB	POLY
10	10	520055	HOSE CLAMP NO 12	STAINLESS
11	1	601436	HOSE, 3/4 X 15	1BR BLK EPDM
12	1	601532	HOSE, 3/4 X 170	1BR BLK EPDM
13	1	601533	HOSE, 3/4 X 223	1BR BLK EPDM
14	1	601534	HOSE, 3/4 X 260	1BR BLK EPDM
15	1	696147	BALL VLV, 1" FLANGE	
16	2	737817	NOZL MT CLMP,1.00 SQ SS,Q-TJET	
17	2	737822	CAP SET, YELLOW QUICK TEEJET	
18	2	737824	QUICK TEEJET SEAT GASKET	
19	2	737829	QUICK TJET EL BODY DIAPH	.75
20	2	900065	5/16UNC X 1" HEX BOLT	
21	4	900265	1/2UNC X 1 1/2 HEX BOLT	
22	2	914002	5/16UNC HEX STOVER NUT	
23	4	914008	1/2UNC HEX STOVER NUT	
24	2	920004	1/2 SAE FLAT WASHER	
25	2	629727	FINISH PLUG FOR 1 IN X 16 GA	

SPLICE INTO
LH NOZZLE SPACING
JUMPER HOSE

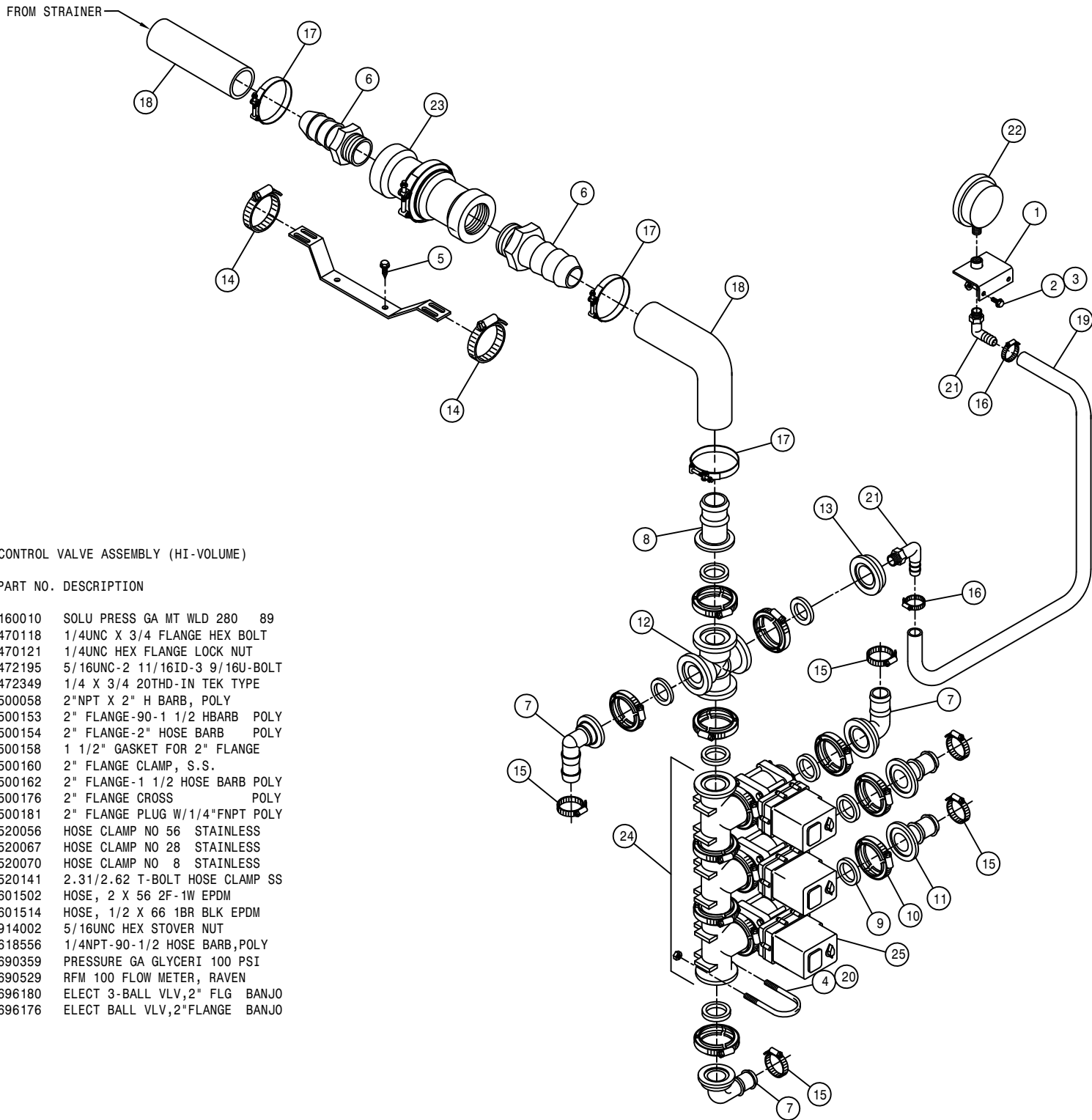

SOLUTION CONTROL VALVE ASSEMBLY (HI-VOLUME)

DET. QTY PART NO. DESCRIPTION

1	1	160010	SOLU PRESS GA MT WLD 280 89
2	2	470118	1/4UNC X 3/4 FLANGE HEX BOLT
3	2	470121	1/4UNC HEX FLANGE LOCK NUT
4	2	472195	5/16UNC-2 11/16ID-3 9/16U-BOLT
5	2	472349	1/4 X 3/4 20THD-IN TEK TYPE
6	2	500058	2"NPT X 2" H BARB, POLY
7	3	500153	2" FLANGE-90-1 1/2 HBARB POLY
8	1	500154	2" FLANGE-2" HOSE BARB POLY
9	8	500158	1 1/2" GASKET FOR 2" FLANGE
10	8	500160	2" FLANGE CLAMP, S.S.
11	2	500162	2" FLANGE-1 1/2 HOSE BARB POLY
12	1	500176	2" FLANGE CROSS POLY
13	1	500181	2" FLANGE PLUG W/1/4"FNPT POLY
14	2	520056	HOSE CLAMP NO 56 STAINLESS
15	5	520067	HOSE CLAMP NO 28 STAINLESS
16	2	520070	HOSE CLAMP NO 8 STAINLESS
17	3	520141	2.31/2.62 T-BOLT HOSE CLAMP SS
18	2	601502	HOSE, 2 X 56 2F-1W EPDM
19	1	601514	HOSE, 1/2 X 66 1BR BLK EPDM
20	4	914002	5/16UNC HEX STOVER NUT
21	2	618556	1/4NPT-90-1/2 HOSE BARB,POLY
22	1	690359	PRESSURE GA GLYCERI 100 PSI
23	1	690529	RFM 100 FLOW METER, RAVEN
24	1	696180	ELECT 3-BALL VLV,2" FLG BANJO
25	3	696176	ELECT BALL VLV,2"FLANGE BANJO

80'-90' SOLUTION VALVE ASSEMBLY (HI-VOLUME)

DET. QTY PART NO. DESCRIPTION

1	2	500158	1 1/2" GASKET FOR 2" FLANGE
2	2	500160	2" FLANGE CLAMP, S.S.
3	2	500162	2" FLANGE-1 1/2 HOSE BARB POLY
4	1	690745	2" SOLU VLV MT WLD
5	1	696176	ELECT BALL VLV, 2" FLANGE BANJO
6	2	520067	HOSE CLAMP NO 28 STAINLESS
7	1	520133	1.81/2.06 T-BOLT HOSE CLAMP SS

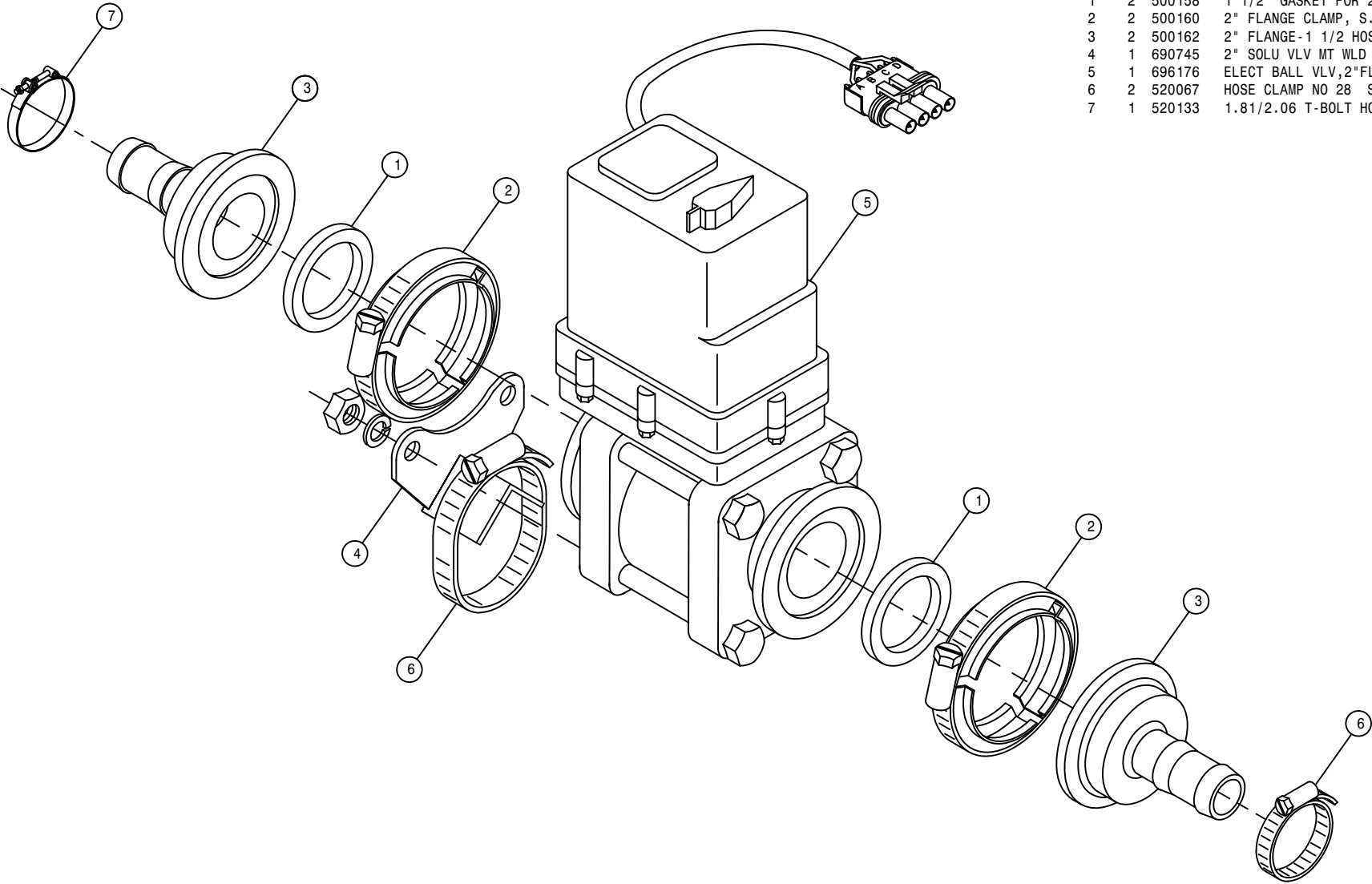

80'-90' FEEDER TEE ASSEMBLY (HI-VOLUME)

DET. QTY PART NO. DESCRIPTION

1	5	500158	1 1/2" GASKET FOR 2" FLANGE
2	5	500160	2" FLANGE CLAMP, S.S.
3	1	500162	2" FLANGE-1 1/2 HOSE BARB POLY
4	3	500172	2" FLANGE-1" HOSE BARB POLY
5	2	500151	2" FLANGE TEE POLY
6	3	520090	HOSE CLAMP NO 16 STAINLESS
7	1	520133	1.81/2.06 T-BOLT HOSE CLAMP SS

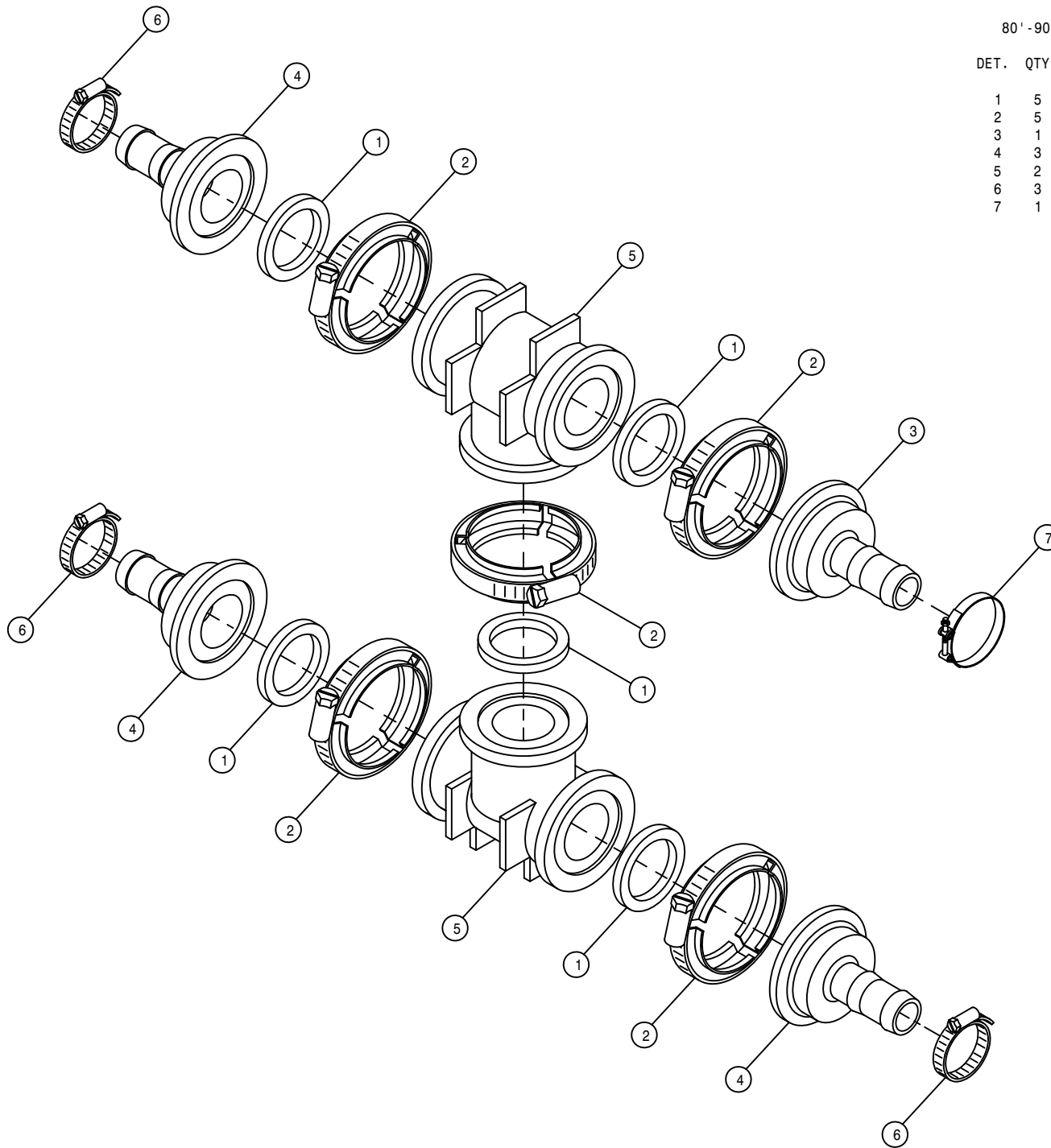

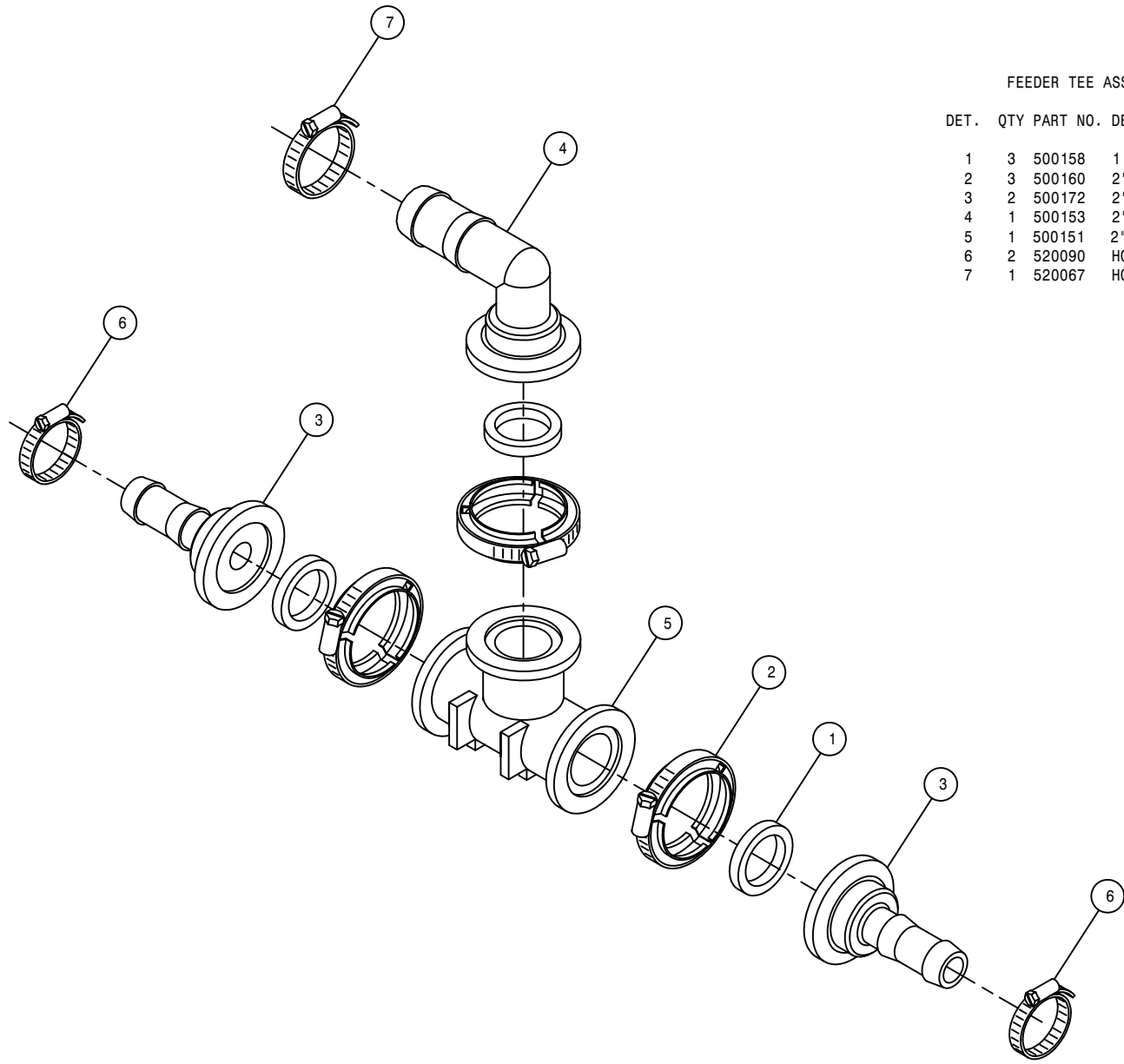

FEEDER TEE ASSEMBLY (HI-VOLUME)

DET. QTY PART NO. DESCRIPTION

1	3	500158	1 1/2" GASKET FOR 2" FLANGE
2	3	500160	2" FLANGE CLAMP, S.S.
3	2	500172	2" FLANGE-1" HOSE BARB POLY
4	1	500153	2" FLANGE-90-1 1/2 HBARB POLY
5	1	500151	2" FLANGE TEE POLY
6	2	520090	HOSE CLAMP NO 16 STAINLESS
7	1	520067	HOSE CLAMP NO 28 STAINLESS

90° BALL VALVE ASSEMBLY (HI-VOLUME)

DET. QTY PART NO. DESCRIPTION

1	2	500157	1" FLANGE GASKET	EPDM
2	2	500159	1" FLANGE CLAMP, S.S.	
3	2	500171	1" FLANGE-1" HOSE BARB	POLY
4	1	701191	1" SOLU VLV MT WLD	
5	1	696147	BALL VLV, 1" FLANGE	
6	1	520085	HOSE CLAMP NO 24	STAINLESS
7	2	520090	HOSE CLAMP NO 16	STAINLESS

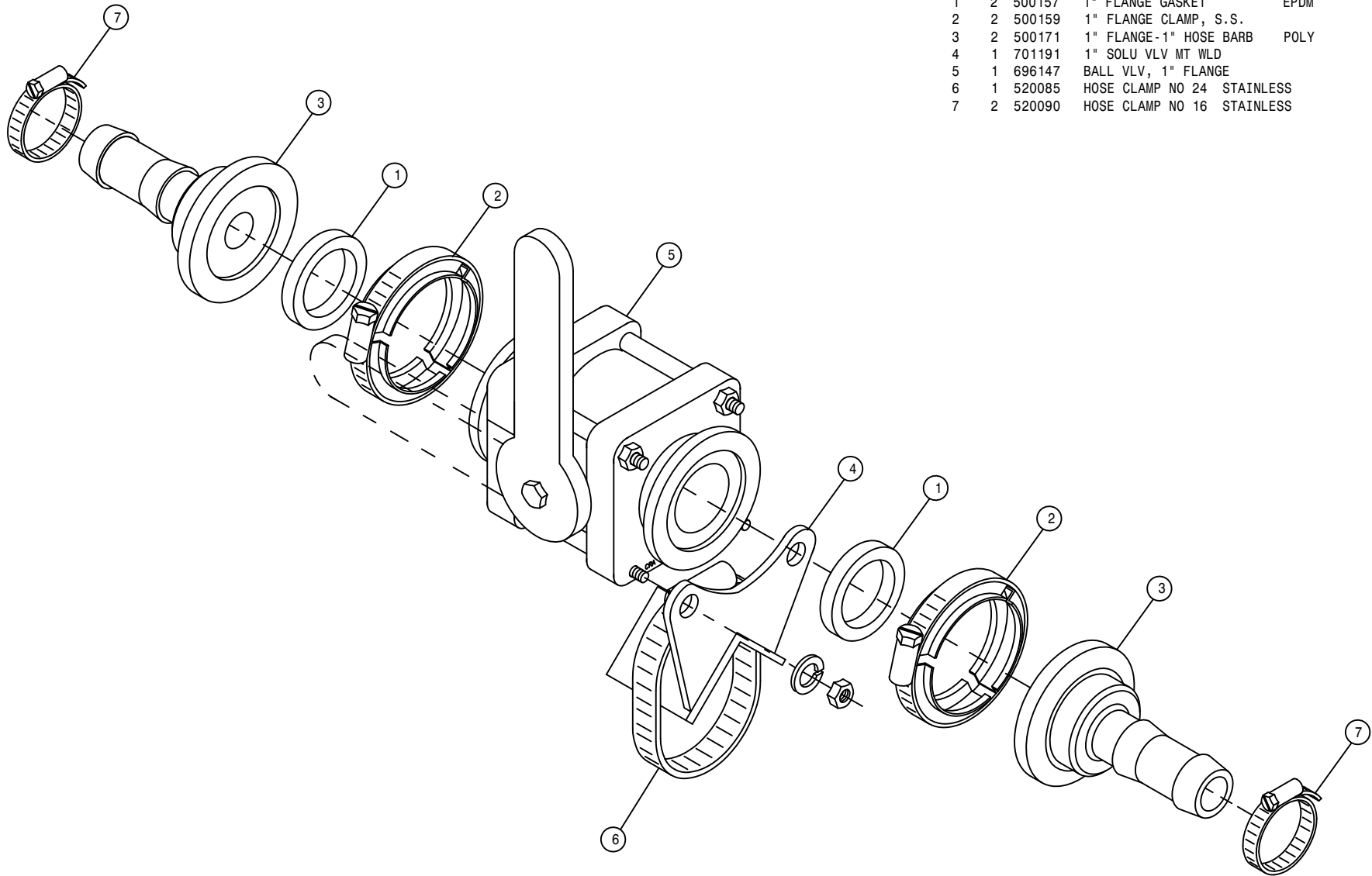

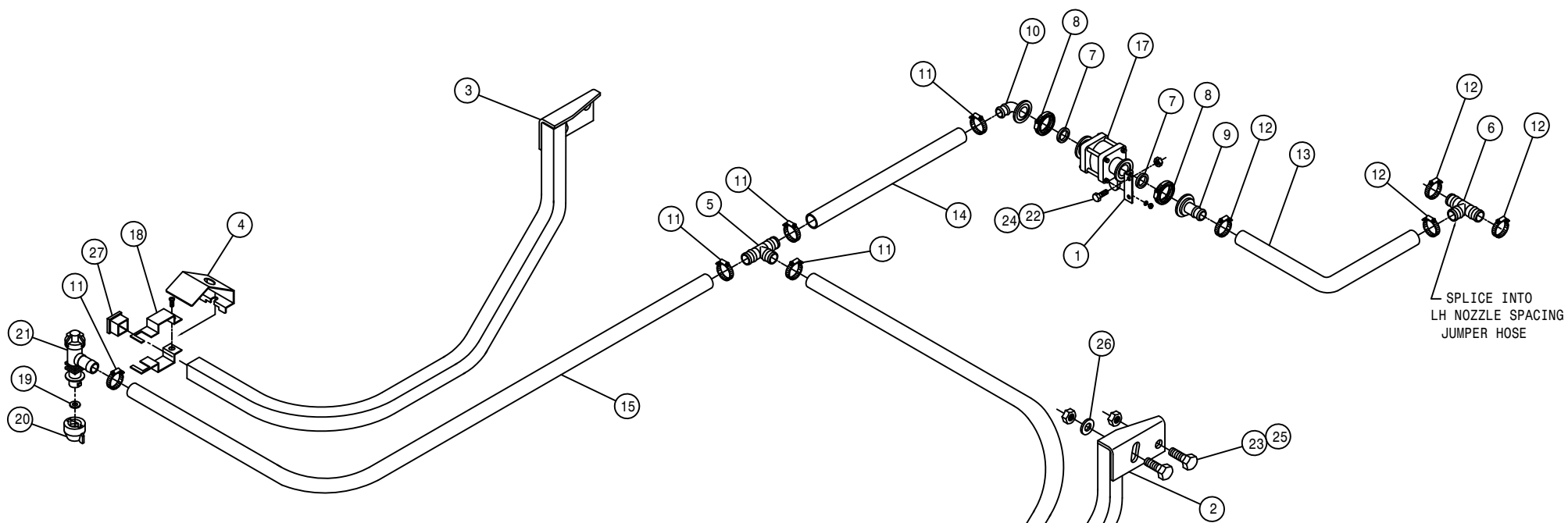

REAR NOZZLE MT OPTION (HI-VOLUME)

DET. QTY PART NO. DESCRIPTION

DET.	QTY	PART NO.	DESCRIPTION
1	1	164669	VALVE MT, REAR NOZL STS12 00
2	1	164670	RH REAR NOZL MT WLD STS12
3	1	164671	LH REAR NOZL MT WLD STS12
4	2	164676	NOZL SHIELD, REAR WHEEL 00
5	1	500073	3/4 HOSE BARB TEE, POLY
6	1	500105	1.00 HOSE BARB TEE, POLY
7	2	500157	1" FLANGE GASKET EPDM
8	2	500159	1" FLANGE CLAMP, S.S.
9	1	500171	1" FLANGE-1" HOSE BARB POLY
10	1	500185	1"FLANGE-90-3/4"HOSE BARB POLY
11	6	520055	HOSE CLAMP NO 12 STAINLESS
12	4	520087	HOSE CLAMP NO 20 STAINLESS
13	1	601531	HOSE, 1 X 15 1BR BLK EPDM
14	1	601532	HOSE, 3/4 X 170 1BR BLK EPDM
15	1	601533	HOSE, 3/4 X 223 1BR BLK EPDM
16	1	601534	HOSE, 3/4 X 260 1BR BLK EPDM
17	1	696147	BALL VLV, 1" FLANGE
18	2	737817	NOZL MT CLMP,1.00 SQ SS,Q-TJET
19	2	737824	QUICK TEEJET SEAT GASKET
20	2	737822	CAP SET, YELLOW QUICK TEEJET
21	2	737829	QUICK TJET EL BODY DIAPH .75
22	2	900065	5/16UNC X 1" HEX BOLT
23	4	900265	1/2UNC X 1 1/2 HEX BOLT
24	2	914002	5/16UNC HEX STOVER NUT
25	4	914008	1/2UNC HEX STOVER NUT
26	2	920004	1/2 SAE FLAT WASHER
27	2	629727	FINISH PLUG FOR 1 IN X 16 GA

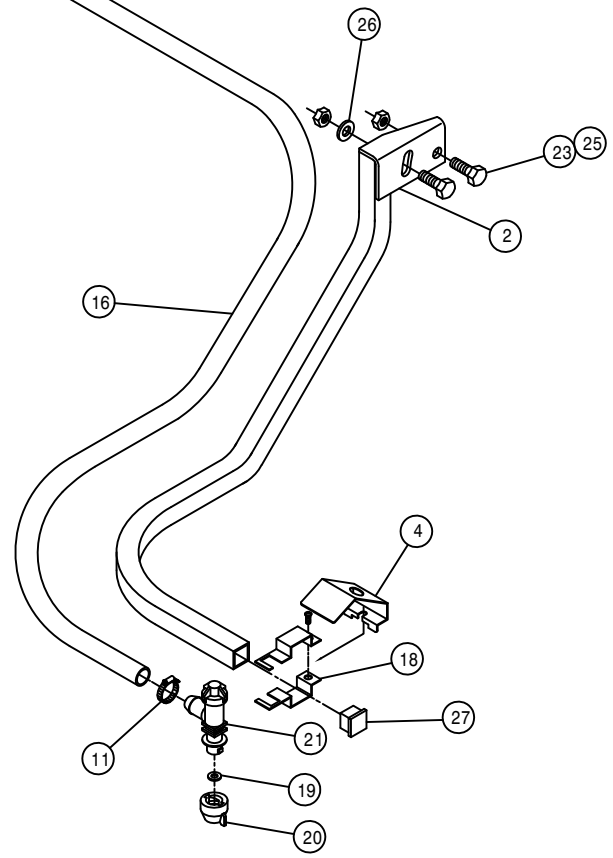

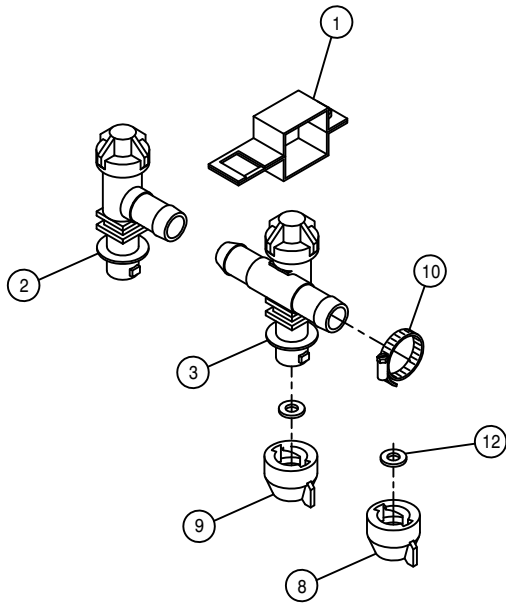

STANDARD SINGLE TIP SPACING

BOOM NOZZLE BODY

DET. QTY PART NO. DESCRIPTION

DET.	QTY	PART NO.	DESCRIPTION
1	3	737817	NOZL MT CLMP,1.00 SQ SS,Q-TJET
2	1	737829	QUICK TJET EL BODY DIAPH .75
3	1	737830	QUICK TJET TEE BODY DIAPH .75
4	1	737833	QUICK TJET LBO,3-TIP BODY .75
5	1	737834	QUICK TJET TEE,3-TIP BODY .75
6	1	737900	QUICK TJET LBO,3-TIP BODY 1.00
7	1	737901	QUICK TJET TEE,3-TIP BODY 1.00
8	3	737825	QUICK TEEJET SHUT-OFF CAP
9	3	737822	CAP SET, YELLOW QUICK TEEJET
10	2	520055	HOSE CLAMP NO 12 STAINLESS
11	1	520090	HOSE CLAMP NO 16 STAINLESS
12	6	737824	QUICK TEEJET SEAT GASKET

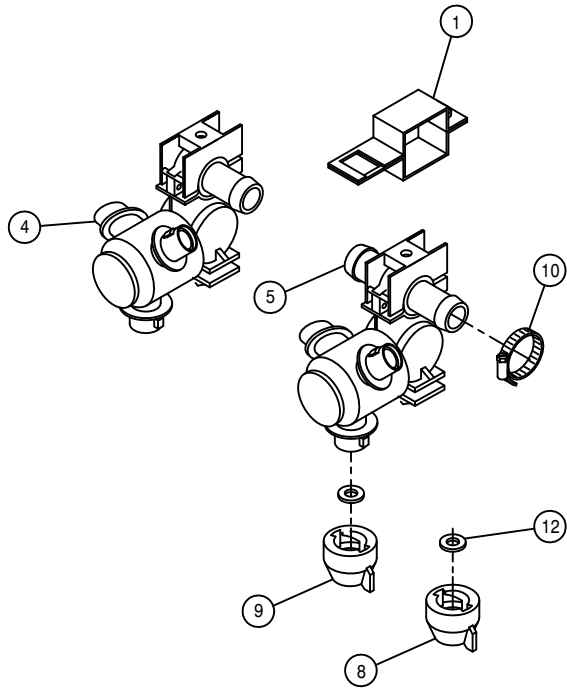

STANDARD TRIPLE TIP SPACING

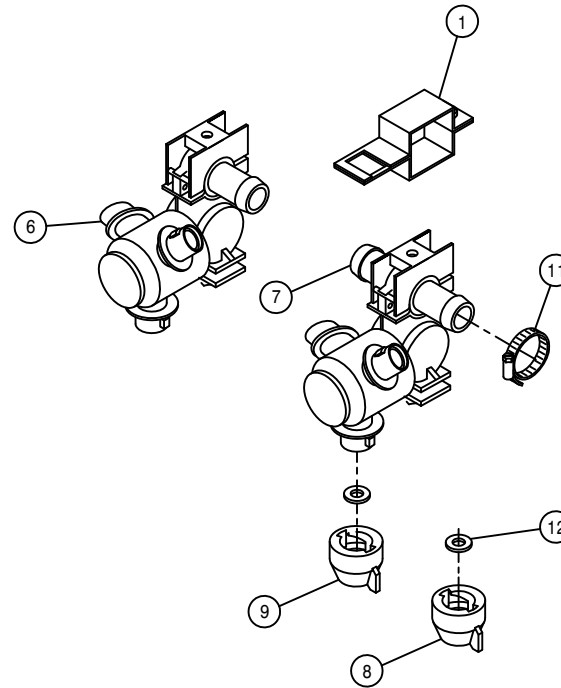

HI-VOLUME TRIPLE TIP SPACING

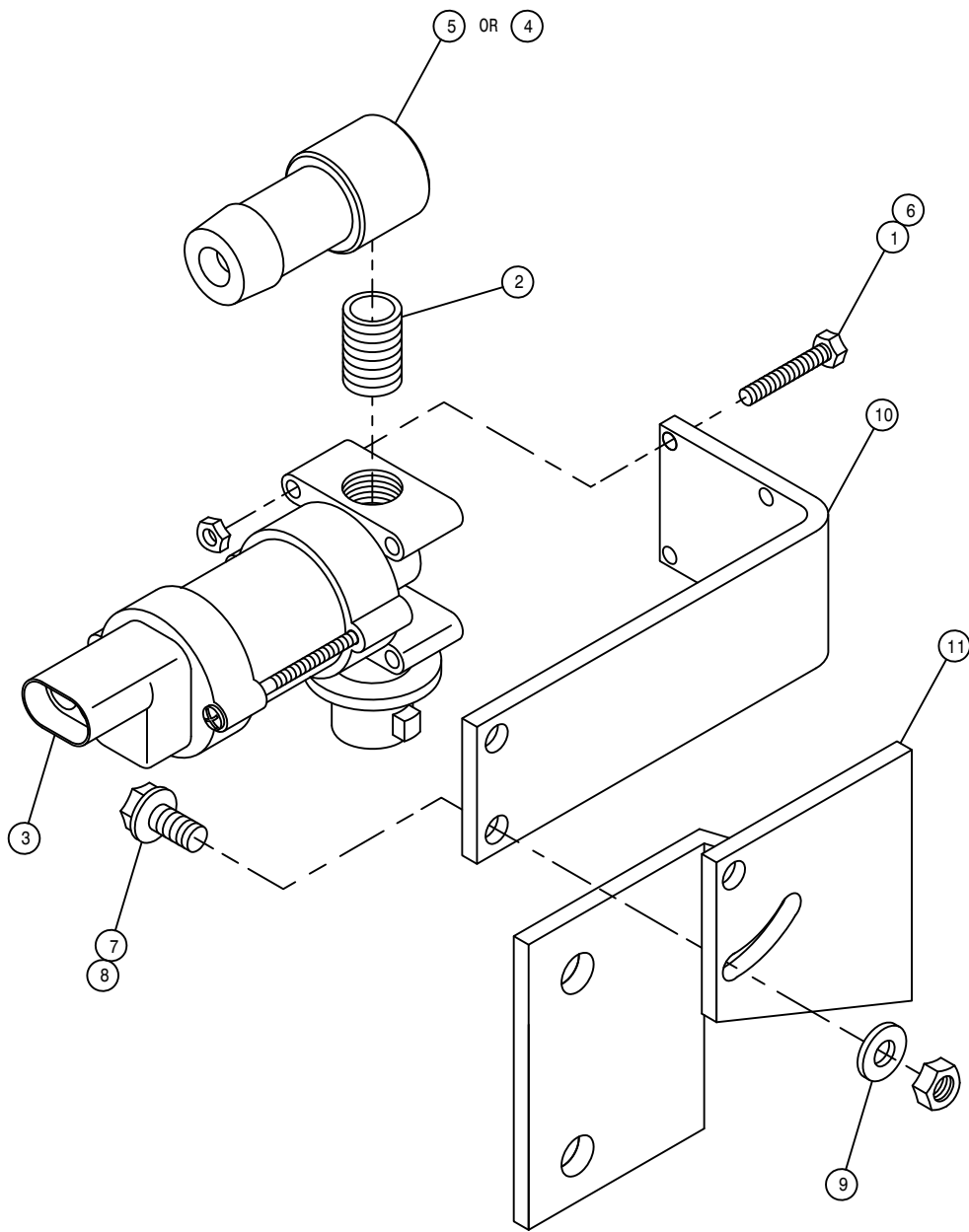

RH FENCE ROW NOZZLE ASSEMBLY

DET. QTY PART NO. DESCRIPTION

1	4	473993	6-32 X 1 1/4 HH MACH SCR
2	1	507022	SS CLOSE PIPE NIPPLE, .25MNPT
3	1	737875	NOZZLE BODY VALVE, 12VDC
4	1	737876	1.00 FENCE ROW NOZZLE HOSEBARB
5	1	737878	.75 FENCE ROW NOZZLE HOSEBARB
6	4	910022	6-32 HEX NUT
7	2	470118	1/4UNC X 3/4 FLANGE HEX BOLT
8	2	914000	1/4UNC HEX STOVER NUT
9	1	920000	1/4 SAE FLAT WASHER
10	1	737906	FENCE ROW NOZL BRKT
11	1	737907	RH FENCE ROW TIP BRKT MT

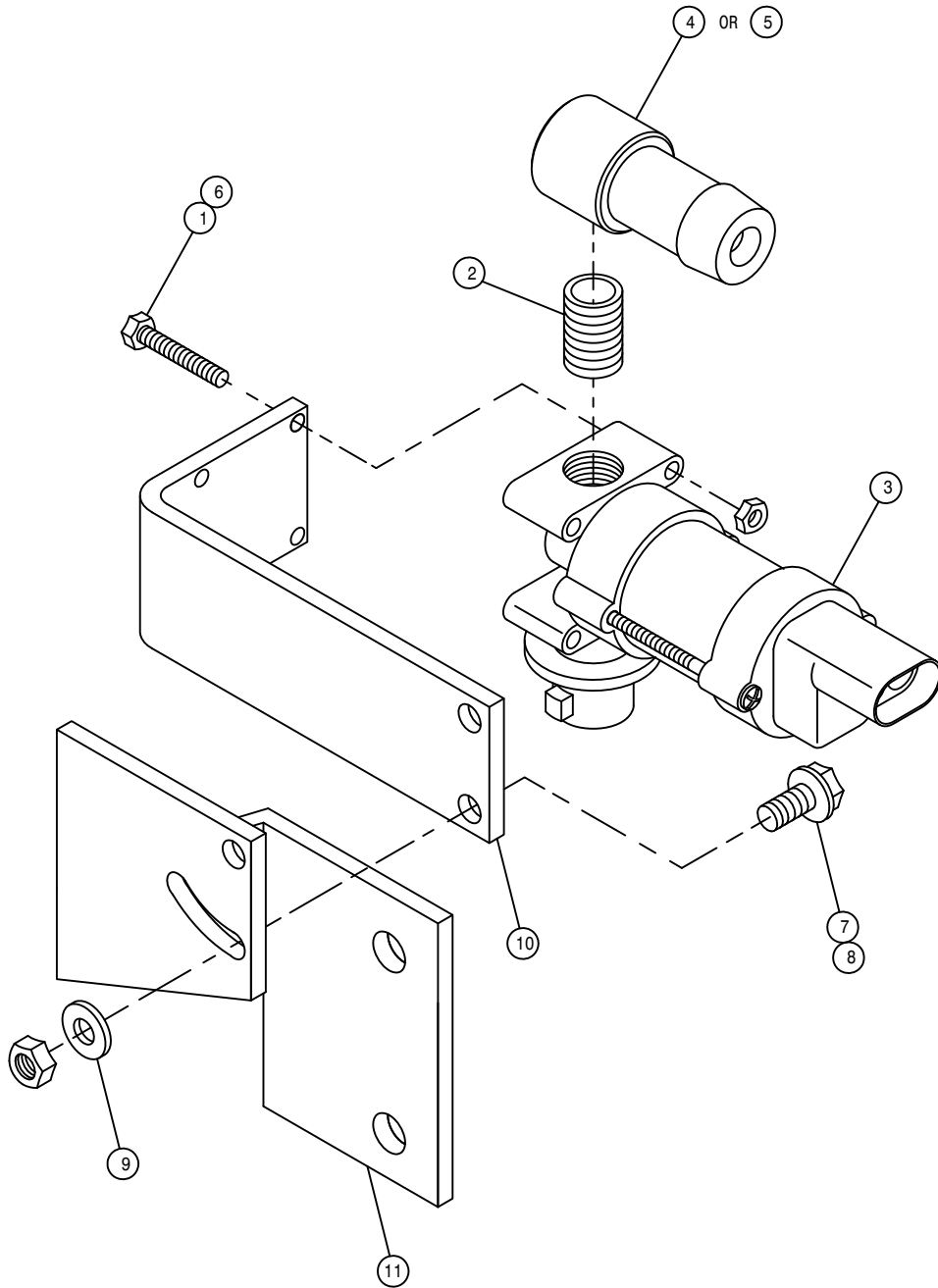

LH FENCE ROW NOZZLE ASSEMBLY

DET.	QTY	PART NO.	DESCRIPTION
1	4	473993	6-32 X 1 1/4 HH MACH SCR
2	1	507022	SS CLOSE PIPE NIPPLE, .25MNPT
3	1	737875	NOZZLE BODY VALVE, 12VDC
4	1	737876	1.00 FENCE ROW NOZZLE HOSEBARB
5	1	737878	.75 FENCE ROW NOZZLE HOSEBARB
6	4	910022	6-32 HEX NUT
7	2	470118	1/4UNC X 3/4 FLANGE HEX BOLT
8	2	914000	1/4UNC HEX STOVER NUT
9	1	920000	1/4 SAE FLAT WASHER
10	1	737906	FENCE ROW NOZL BRKT
11	1	737908	LH FENCE ROW TIP BRKT MT

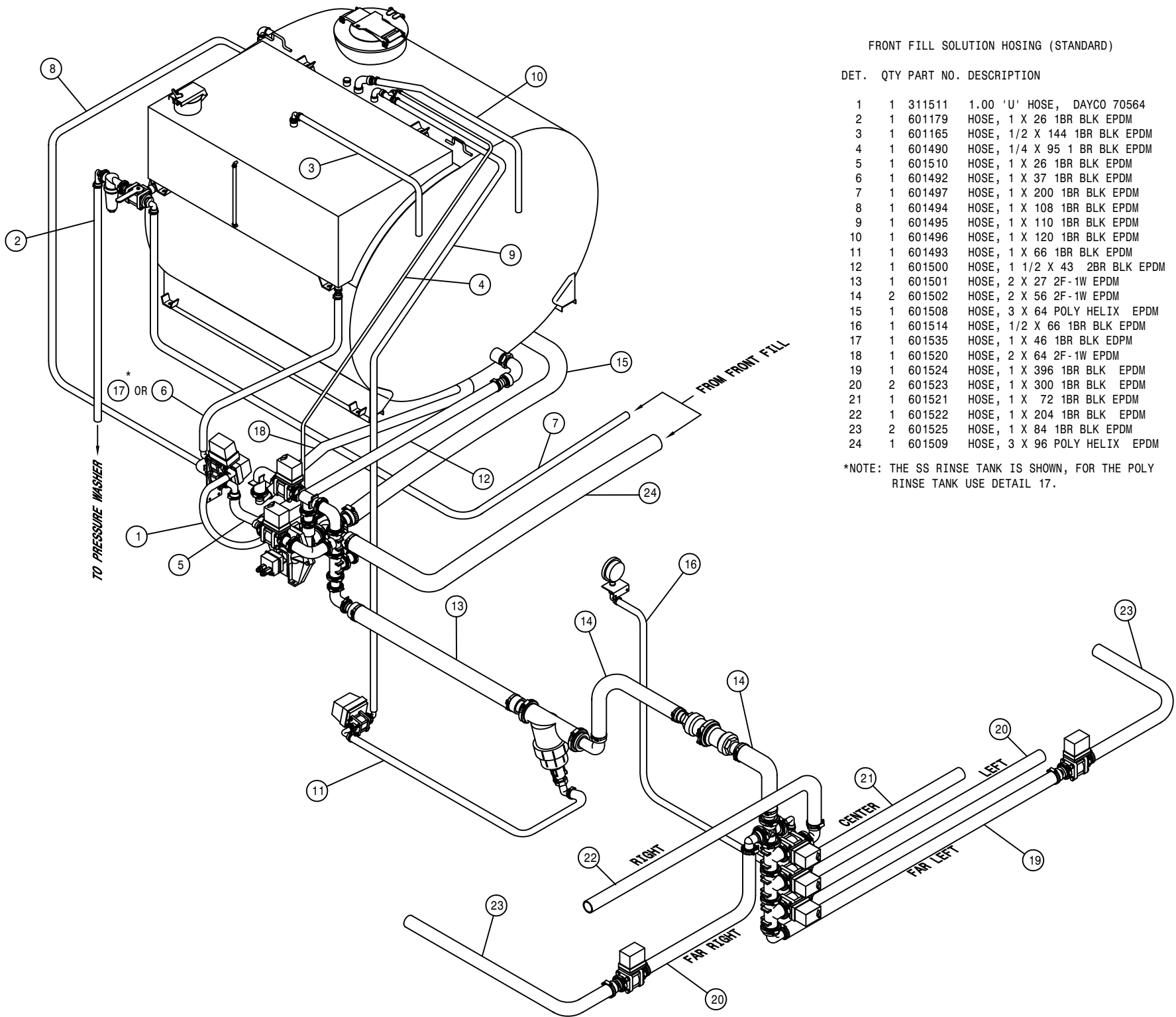

FRONT FILL SOLUTION HOISING (STANDARD)

DET.	QTY	PART NO.	DESCRIPTION
1	1	311511	1.00 'U' HOSE, DAYCO 70564
2	1	601179	HOSE, 1 X 26 1BR BLK EPDM
3	1	601165	HOSE, 1/2 X 144 1BR BLK EPDM
4	1	601490	HOSE, 1/4 X 95 1 BR BLK EPDM
5	1	601510	HOSE, 1 X 26 1BR BLK EPDM
6	1	601492	HOSE, 1 X 37 1BR BLK EPDM
7	1	601497	HOSE, 1 X 200 1BR BLK EPDM
8	1	601494	HOSE, 1 X 108 1BR BLK EPDM
9	1	601495	HOSE, 1 X 110 1BR BLK EPDM
10	1	601496	HOSE, 1 X 120 1BR BLK EPDM
11	1	601493	HOSE, 1 X 66 1BR BLK EPDM
12	1	601500	HOSE, 1 1/2 X 43 2BR BLK EPDM
13	1	601501	HOSE, 2 X 27 2F-1W EPDM
14	2	601502	HOSE, 2 X 56 2F-1W EPDM
15	1	601508	HOSE, 3 X 64 POLY HELIX EPDM
16	1	601514	HOSE, 1/2 X 66 1BR BLK EPDM
17	1	601535	HOSE, 1 X 46 1BR BLK EDPM
18	1	601520	HOSE, 2 X 64 2F-1W EPDM
19	1	601524	HOSE, 1 X 396 1BR BLK EPDM
20	2	601523	HOSE, 1 X 300 1BR BLK EPDM
21	1	601521	HOSE, 1 X 72 1BR BLK EPDM
22	1	601522	HOSE, 1 X 204 1BR BLK EPDM
23	2	601525	HOSE, 1 X 84 1BR BLK EPDM
24	1	601509	HOSE, 3 X 96 POLY HELIX EPDM

*NOTE: THE SS RINSE TANK IS SHOWN, FOR THE POLY RINSE TANK USE DETAIL 17.

SIDE FILL SOLUTION HOISING (STANDARD)

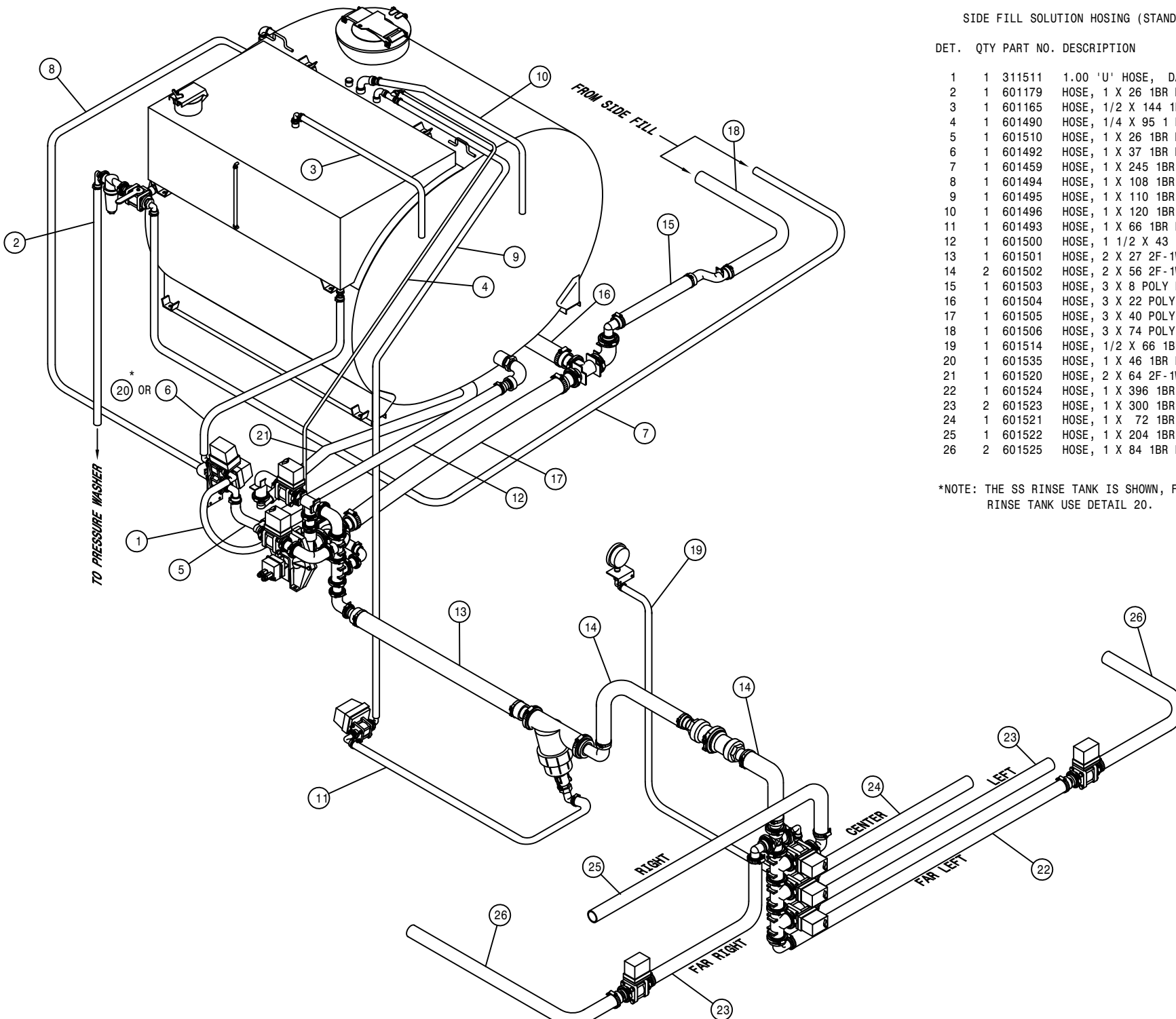

DET. QTY PART NO. DESCRIPTION

1	1	311511	1.00 'U' HOSE, DAYCO 70564
2	1	601179	HOSE, 1 X 26 1BR BLK EPDM
3	1	601165	HOSE, 1/2 X 144 1BR BLK EPDM
4	1	601490	HOSE, 1/4 X 95 1 BR BLK EPDM
5	1	601510	HOSE, 1 X 26 1BR BLK EPDM
6	1	601492	HOSE, 1 X 37 1BR BLK EPDM
7	1	601459	HOSE, 1 X 245 1BR BLK EPDM
8	1	601494	HOSE, 1 X 108 1BR BLK EPDM
9	1	601495	HOSE, 1 X 110 1BR BLK EPDM
10	1	601496	HOSE, 1 X 120 1BR BLK EPDM
11	1	601493	HOSE, 1 X 66 1BR BLK EPDM
12	1	601500	HOSE, 1 1/2 X 43 2BR BLK EPDM
13	1	601501	HOSE, 2 X 27 2F-1W EPDM
14	2	601502	HOSE, 2 X 56 2F-1W EPDM
15	1	601503	HOSE, 3 X 8 POLY HELIX EPDM
16	1	601504	HOSE, 3 X 22 POLY HELIX EPDM
17	1	601505	HOSE, 3 X 40 POLY HELIX EPDM
18	1	601506	HOSE, 3 X 74 POLY HELIX EPDM
19	1	601514	HOSE, 1/2 X 66 1BR BLK EPDM
20	1	601535	HOSE, 1 X 46 1BR BLK EPDM
21	1	601520	HOSE, 2 X 64 2F-1W EPDM
22	1	601524	HOSE, 1 X 396 1BR BLK EPDM
23	2	601523	HOSE, 1 X 300 1BR BLK EPDM
24	1	601521	HOSE, 1 X 72 1BR BLK EPDM
25	1	601522	HOSE, 1 X 204 1BR BLK EPDM
26	2	601525	HOSE, 1 X 84 1BR BLK EPDM

*NOTE: THE SS RINSE TANK IS SHOWN, FOR THE POLY RINSE TANK USE DETAIL 20.

FRONT FILL SOLUTION TANK HOISING (HI-VOL)

DET. QTY PART NO. DESCRIPTION

1	1	311511	1.00 'U' HOSE, DAYCO 70564
2	1	601179	HOSE, 1 X 26 1BR BLK EPDM
3	1	601165	HOSE, 1/2 X 144 1BR BLK EPDM
4	1	601490	HOSE, 1/4 X 95 1 BR BLK EPDM
5	1	601510	HOSE, 1 X 26 1BR BLK EPDM
6	1	601492	HOSE, 1 X 37 1BR BLK EPDM
7	1	601497	HOSE, 1 X 200 1BR BLK EPDM
8	1	601494	HOSE, 1 X 108 1BR BLK EPDM
9	1	601495	HOSE, 1 X 110 1BR BLK EPDM
10	1	601496	HOSE, 1 X 120 1BR BLK EPDM
11	1	601493	HOSE, 1 X 66 1BR BLK EPDM
12	1	601500	HOSE, 1 1/2 X 43 2BR BLK EPDM
13	1	601501	HOSE, 2 X 27 2F-1W EPDM
14	2	601502	HOSE, 2 X 56 2F-1W EPDM
15	1	601508	HOSE, 3 X 64 POLY HELIX EPDM
16	1	601514	HOSE, 1/2 X 66 1BR BLK EPDM
17	1	601535	HOSE, 1 X 46 1BR BLK EPDM
18	1	601520	HOSE, 2 X 64 2F-1W EPDM
19	1	601519	HOSE, 1 1/2 X 396 2BR BLK EPDM
20	2	601518	HOSE, 1 1/2 X 300 2BR BLK EPDM
21	1	601516	HOSE, 1 1/2 X 72 2BR BLK EPDM
22	1	601517	HOSE, 1 1/2 X 204 2BR BLK EPDM
23	2	601240	HOSE, 1 1/2 X 84 2F-1W EPDM
24	1	601509	HOSE, 3 X 96 POLY HELIX EPDM

*NOTE: THE SS RINSE TANK IS SHOWN, FOR THE POLY RINSE TANK USE DETAIL 17.

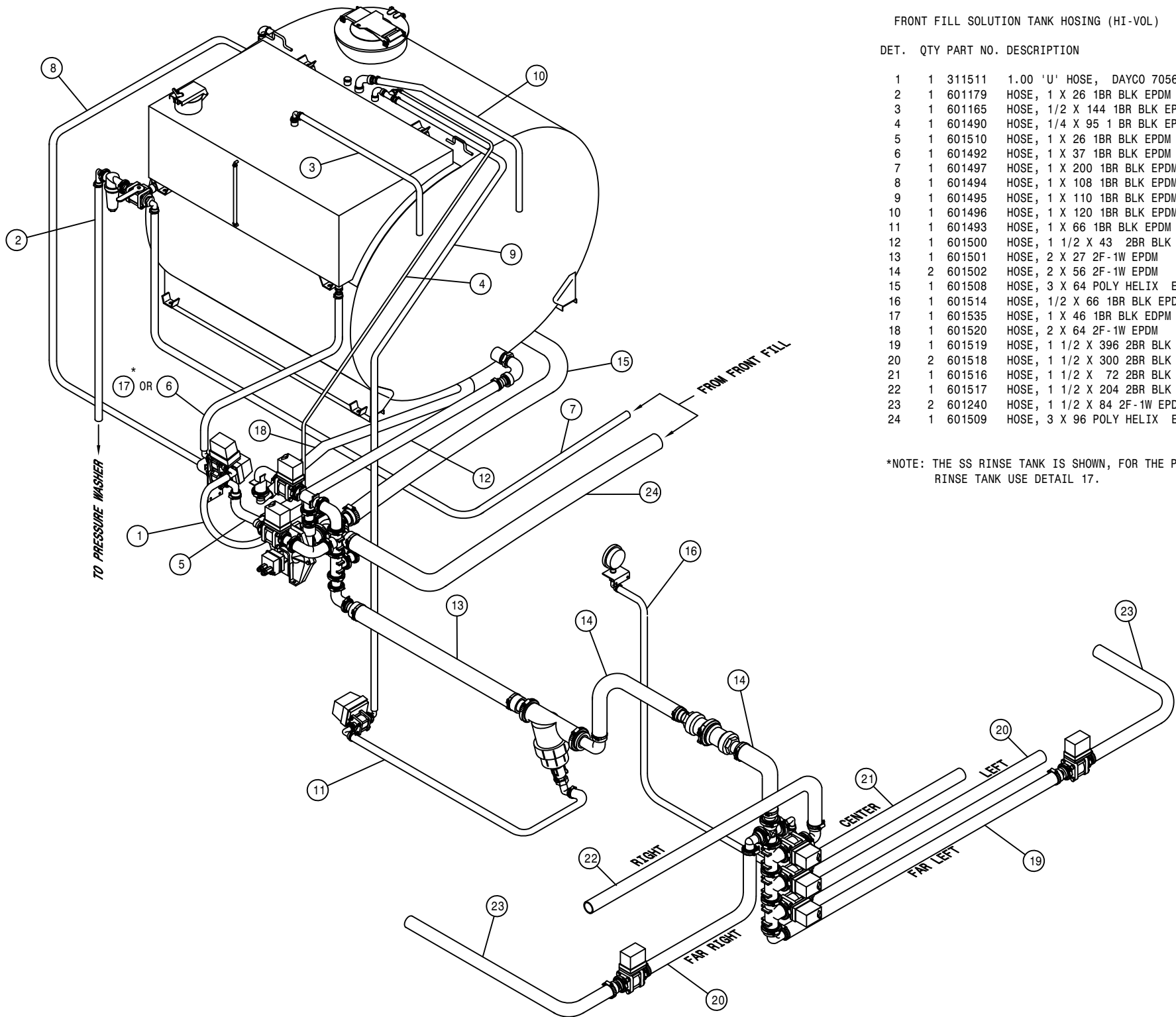

SIDE FILL SOLUTION HOISING (HI-VOL)

DET. QTY PART NO. DESCRIPTION

DET.	QTY	PART NO.	DESCRIPTION
1	1	311511	1.00 'U' HOSE, DAYCO 70564
2	1	601179	HOSE, 1 X 26 1BR BLK EPDM
3	1	601165	HOSE, 1/2 X 144 1BR BLK EPDM
4	1	601490	HOSE, 1/4 X 95 1 BR BLK EPDM
5	1	601510	HOSE, 1 X 26 1BR BLK EPDM
6	1	601492	HOSE, 1 X 37 1BR BLK EPDM
7	1	601459	HOSE, 1 X 245 1BR BLK EPDM
8	1	601494	HOSE, 1 X 108 1BR BLK EPDM
9	1	601495	HOSE, 1 X 110 1BR BLK EPDM
10	1	601496	HOSE, 1 X 120 1BR BLK EPDM
11	1	601493	HOSE, 1 X 66 1BR BLK EPDM
12	1	601500	HOSE, 1 1/2 X 43 2BR BLK EPDM
13	1	601501	HOSE, 2 X 27 2F-1W EPDM
14	2	601502	HOSE, 2 X 56 2F-1W EPDM
15	1	601503	HOSE, 3 X 8 POLY HELIX EPDM
16	1	601504	HOSE, 3 X 22 POLY HELIX EPDM
17	1	601505	HOSE, 3 X 40 POLY HELIX EPDM
18	1	601506	HOSE, 3 X 74 POLY HELIX EPDM
19	1	601514	HOSE, 1/2 X 66 1BR BLK EPDM
20	1	601535	HOSE, 1 X 46 1BR BLK EPDM
21	1	601520	HOSE, 2 X 64 2F-1W EPDM
22	1	601519	HOSE, 1 1/2 X 396 2BR BLK EPDM
23	2	601518	HOSE, 1 1/2 X 300 2BR BLK EPDM
24	1	601516	HOSE, 1 1/2 X 72 2BR BLK EPDM
25	1	601517	HOSE, 1 1/2 X 204 2BR BLK EPDM
26	2	601240	HOSE, 1 1/2 X 84 2F-1W EPDM

*NOTE: THE SS RINSE TANK IS SHOWN, FOR THE POLY RINSE TANK USE DETAIL 20.

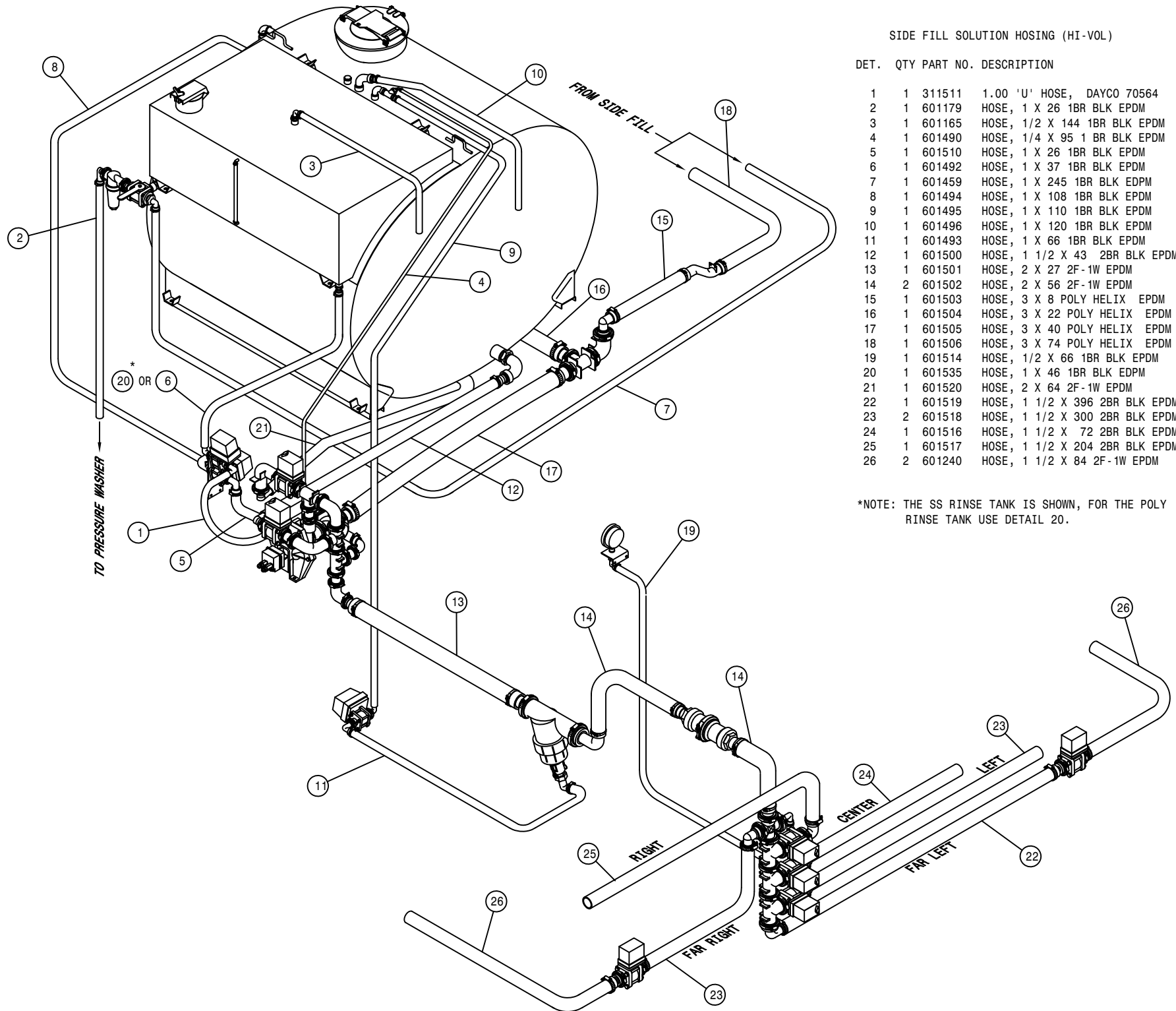

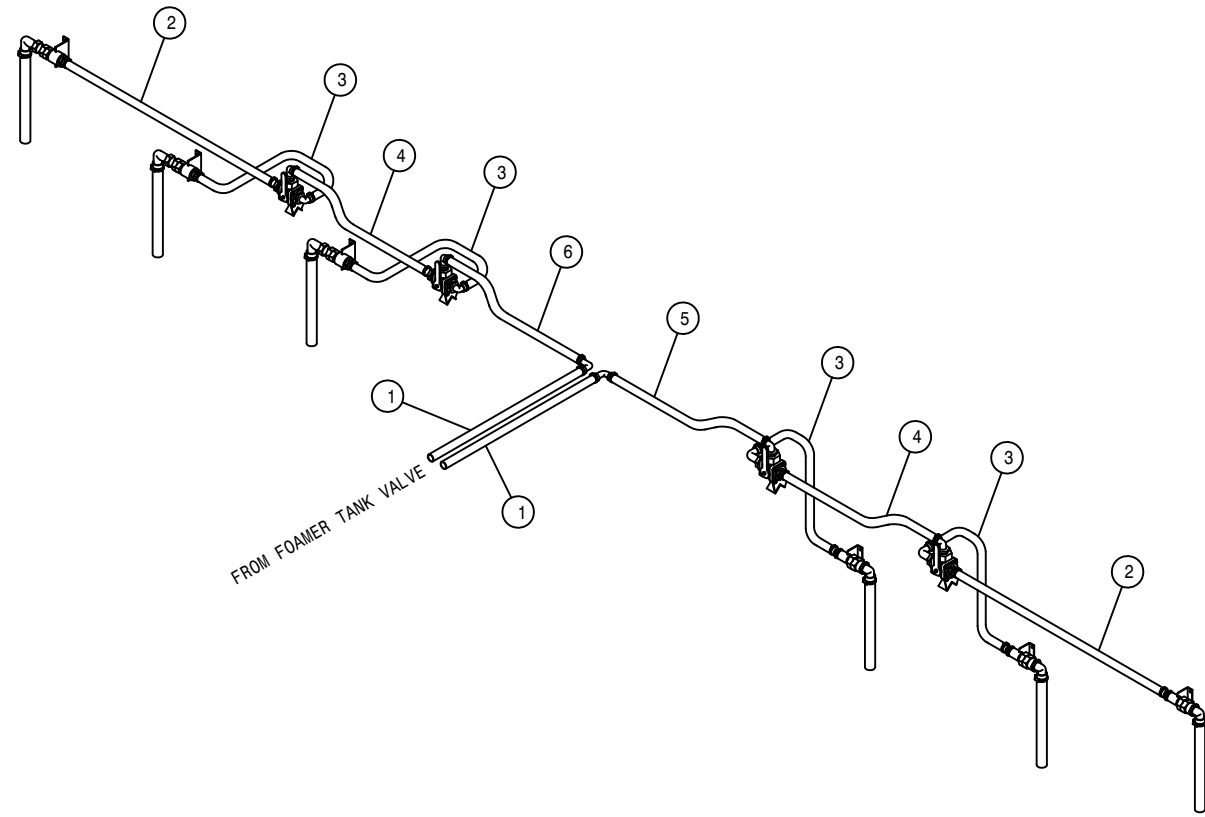

90' BOOM FOAMER HOSING

DET.	QTY	PART NO.	DESCRIPTION
1	2	195908	HOSE, 3/4ID-1/8W CLEAR VINYL X 206"
2	2	195908	HOSE, 3/4ID-1/8W CLEAR VINYL X 77"
3	4	195908	HOSE, 3/4ID-1/8W CLEAR VINYL X 24"
4	2	195908	HOSE, 3/4ID-1/8W CLEAR VINYL X 128"
5	1	195908	HOSE, 3/4ID-1/8W CLEAR VINYL X 420"
6	1	195908	HOSE, 3/4ID-1/8W CLEAR VINYL X 584"

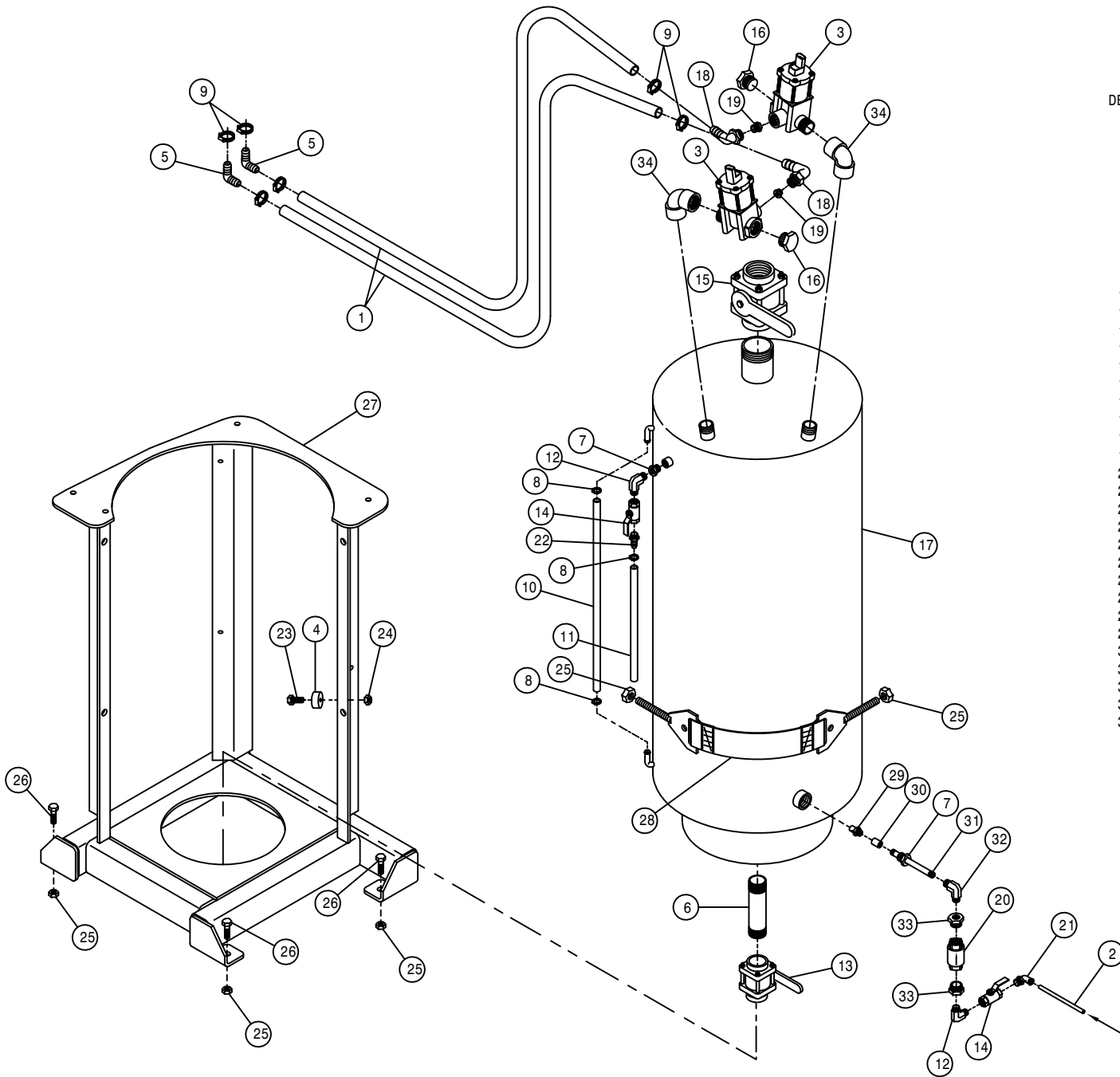

FOAMER TANK ASSEMBLY

DET.	QTY	PART NO.	DESCRIPTION
	2	195908	HOSE, 3/4ID-1/8W CLEAR VINYL X 206.00
	1	601481	HOSE, 3/8 X 68 AIR
	2	696181	3/4" ELECT SOLU SOLE VALVE 02
	6	470294	RUBBER BUMPER, RECESS, .63H-1.5D
	2	500069	3/4-90-3/4 HOSE BARB, POLY
	1	505205	BLK PIPE NIPPLE 1.00NPT-5.00
	2	505211	3/8-1/4NPT REDU BUSH, BRS
	3	520120	HOSE CLAMP NO 4 STAINLESS
	6	520055	HOSE CLAMP NO 12 STAINLESS
	1	601419	HOSE, 3/8 X 30 CLEAR VINYL
	1	601420	HOSE, 3/8 X 48 CLEAR VINYL
	2	618571	1/4MNPT-90-1/4MNPT LBO
	1	695900	BALL VALVE 1IN FNPT POLY
	2	696120	BALL VALVE, 1/4NPT, STEEL
	1	696134	BALL VALVE 2IN FNPT POLY
	2	500043	3/4NPT PIPE PLUG, POLY
	1	701112	FOAM MARKER TANK, 36 GAL SS
	2	701214	1/2NPT-90-3/4HBRB, 1/4TAP, POLY
	2	701215	1/4PIPE PLUG, .187 ORIFICE, POLY
	1	711050	3/4"FNPT CHECK VALVE S.S.
	1	711043	1/4MNPT-3/8 NYL TUBE SNGL LBO
	1	783304	1/4 NPT X 3/8 HOSE BARB, BRS
	6	900064	5/16UNC X 3/4 HEX BOLT
	6	914002	5/16UNC HEX STOVER NUT
	7	914008	1/2UNC HEX STOVER NUT
	3	900264	1/2UNC X 1 1/4 HEX BOLT
	1	701158	FOAMER TANK MT WLD STS12 2000
	2	701170	FOAMER TANK STRAP ASSY
	1	701144	FOAMER AIR NOZZLE
	1	500202	SS PIPE CPLG, 1/8NPT .563 OD
	1	507021	SS PIPE NIPPLE, 1/8NPT X 6"
	1	701143	FOAMER AIR TUBE FTG
	2	507724	REDU BUSH 3/4MNPT X 1/4FNPT, SS
	2	500079	3/4NPT-90 EL, POLY

FROM AIR REGULATOR

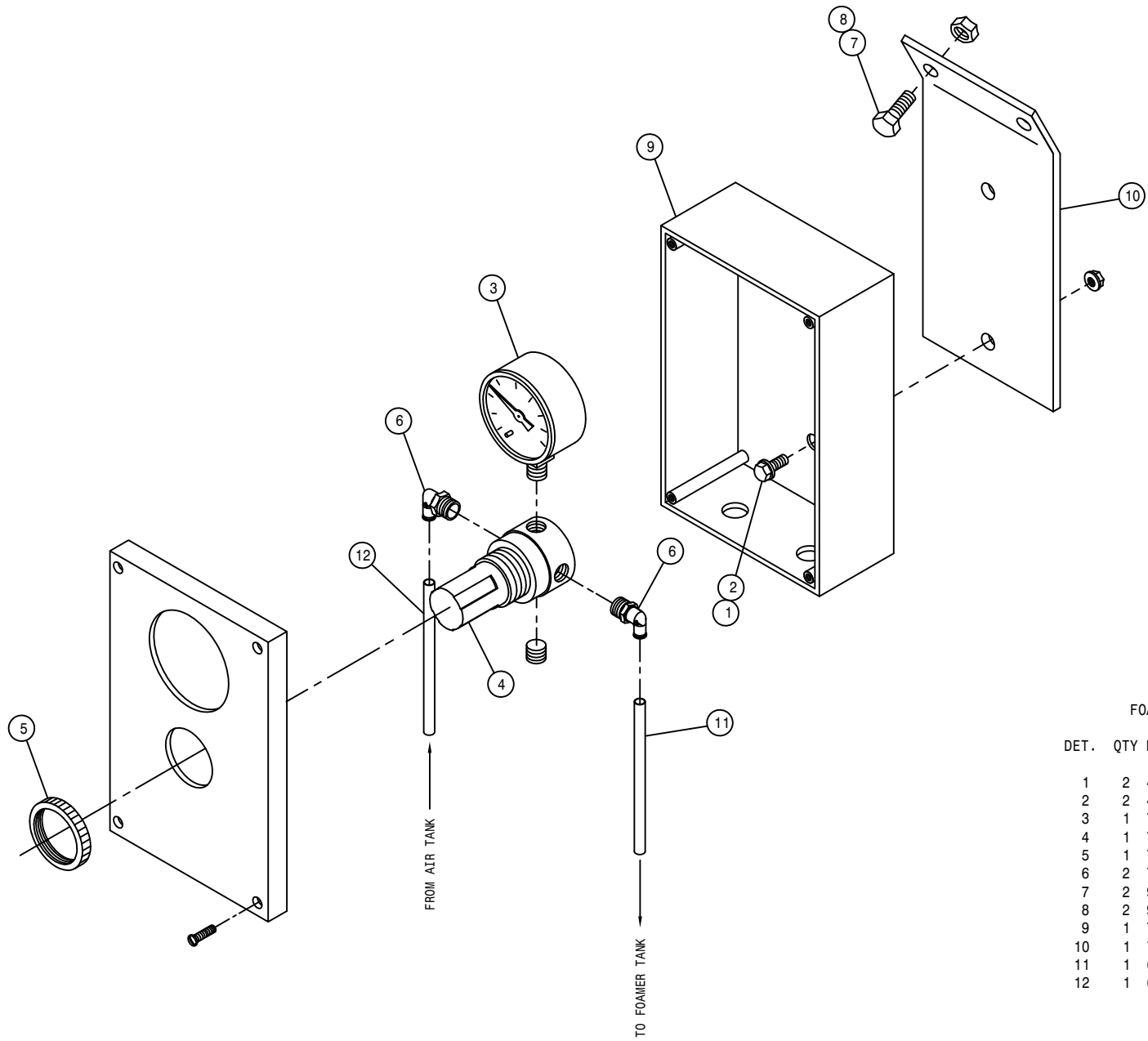

FOAMER AIR REGULATOR ASSEMBLY

DET.	QTY	PART NO.	DESCRIPTION
	1	2 470113	5/16UNC HEX FLANGE LOCK NUT
	2	470232	5/16UNC X 1/2 FLANGE HEX BOLT
	3	701310	AIR PRESS GAUGE, 1/8"BOT
	4	711019	1/4"MNPT AIR REGULATOR
	5	711021	1 1/4-18 NUT,AIR REGULATOR MT
	6	2 711043	1/4MNPT-3/8 NYL TUBE SNGL LBO
	7	2 900064	5/16UNC X 3/4 HEX BOLT
	8	2 914002	5/16UNC HEX STOVER NUT
	9	1 701184	FOAMER AIR REG MT BOX, STS12
	10	1 701183	FOAMER AIR REG MT BOX MT,STS12
	11	1 601481	HOSE, 3/8 X 68 AIR
	12	1 601482	HOSE, 3/8 X 80 AIR

FRESH WATER TANK ASSEMBLY

DET. QTY PART NO. DESCRIPTION

1	1	470318	RINSE TANK, 3 GAL SQ SAFETY
2	1	500019	3/4NPT-1/2HOSE BARB, POLY
3	1	500047	1/2NPT-90-1/2 HOSE BARB, POLY
4	2	520070	HOSE CLAMP NO 8 STAINLESS
5	1	601489	HOSE, 1/2 X 72 CLEAR VINYL
6	1	696082	BALL VALVE 1/2FNPT POLY
7	1	713340	1/2NPT-1/2 HOSE BARB, POLY
8	4	900064	5/16UNC X 3/4 HEX BOLT
9	5	900129	3/8UNC X 1" HEX BOLT
10	5	914004	3/8UNC HEX STOVER NUT
11	4	920501	5/16 LOCK WASHER
12	1	701174	FRESH WATER TANK MT WLD
13	1	701180	FRESH WATER TANK BRACE WLD
14	1	470337	6" LID FOR 3 GAL TANK 470318

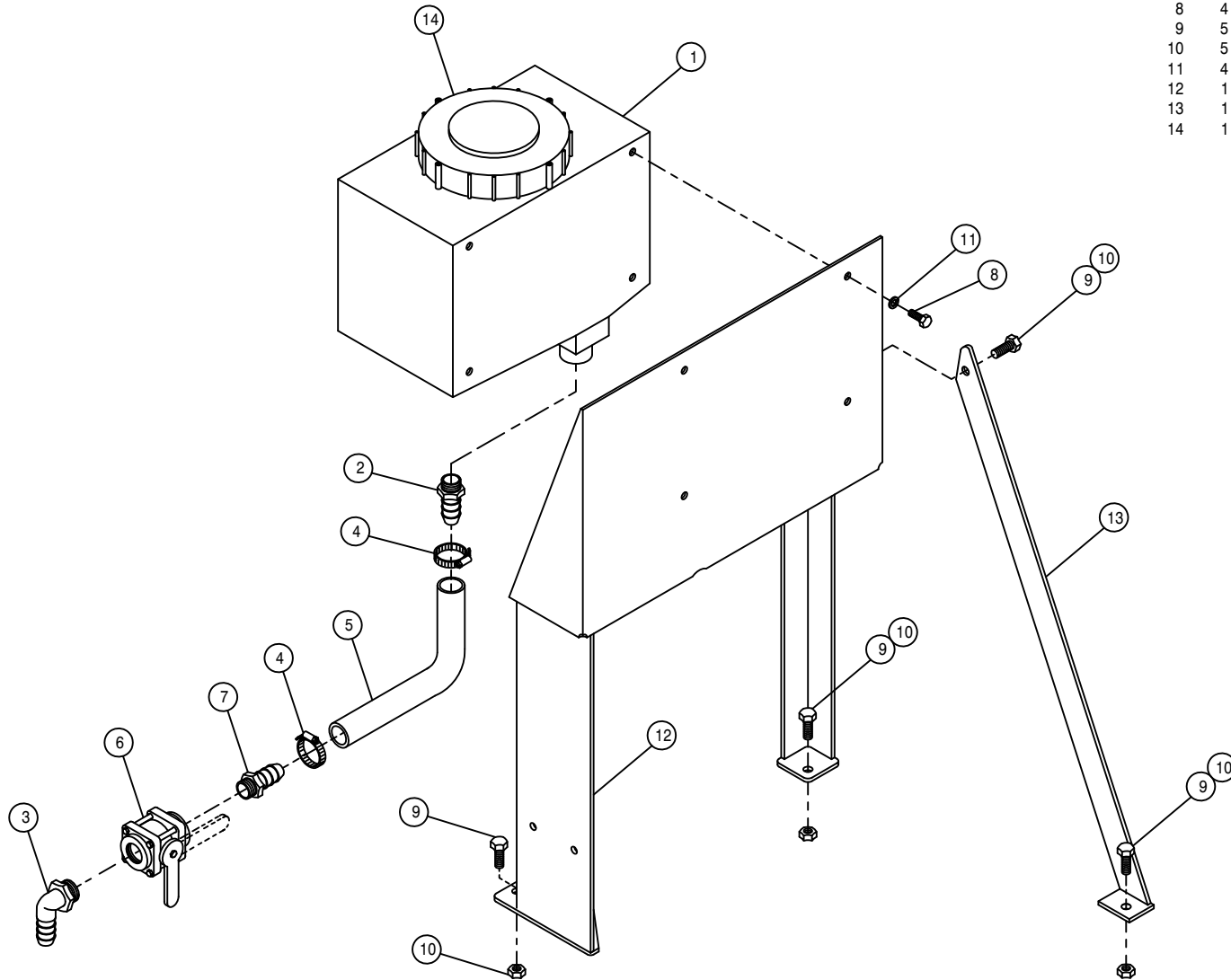

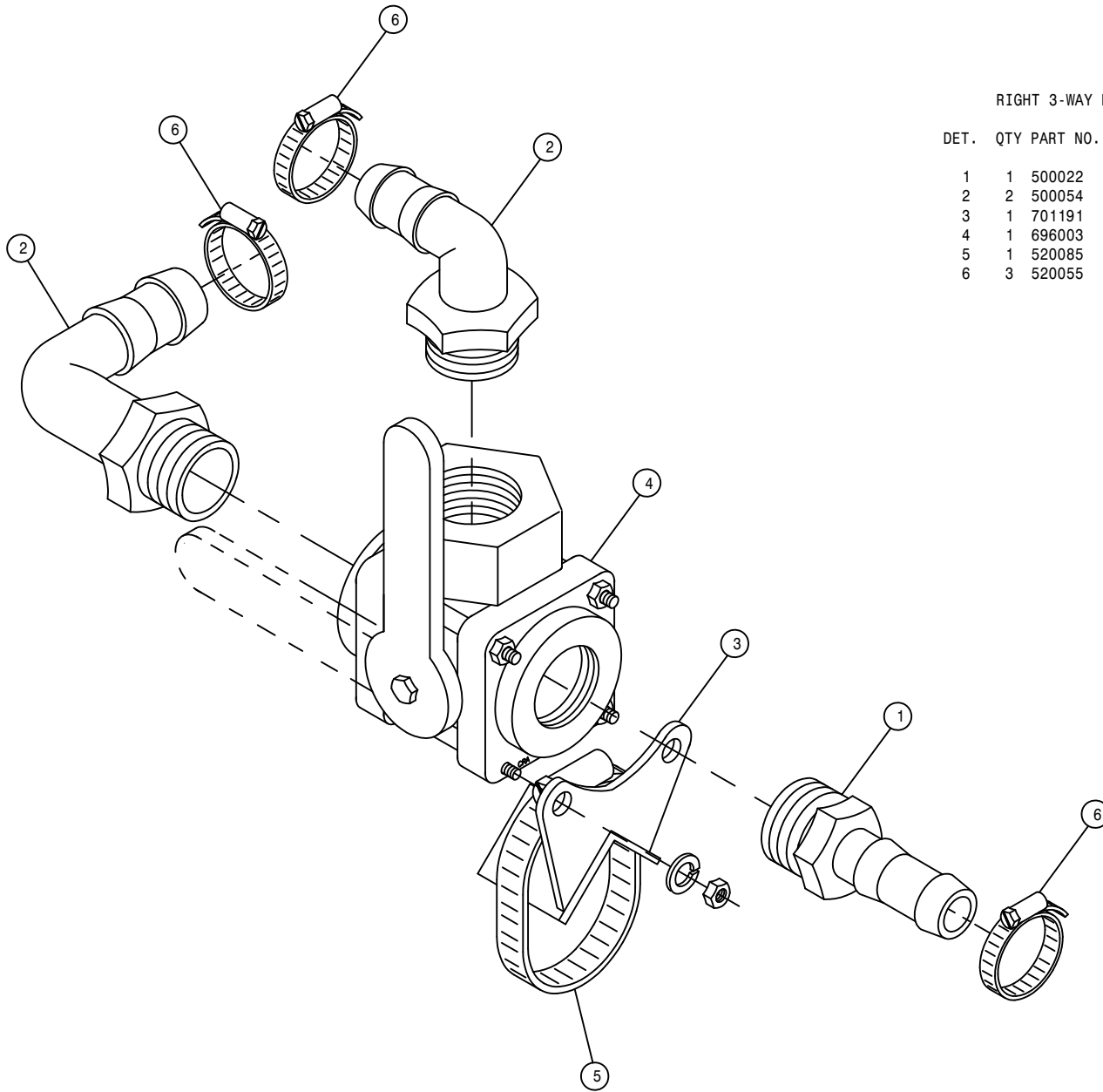

RIGHT 3-WAY FOAMER VALVE ASSEMBLY

DET.	QTY	PART NO.	DESCRIPTION
1	1	500022	3/4NPT-3/4HOSE BARB, POLY
2	2	500054	3/4NPT-90-3/4 HOSE BARB, POLY
3	1	701191	1" SOLU VLV MT WLD
4	1	696003	BALL VLV,3/4NPT 3WAY-SIDE POLY
5	1	520085	HOSE CLAMP NO 24 STAINLESS
6	3	520055	HOSE CLAMP NO 12 STAINLESS

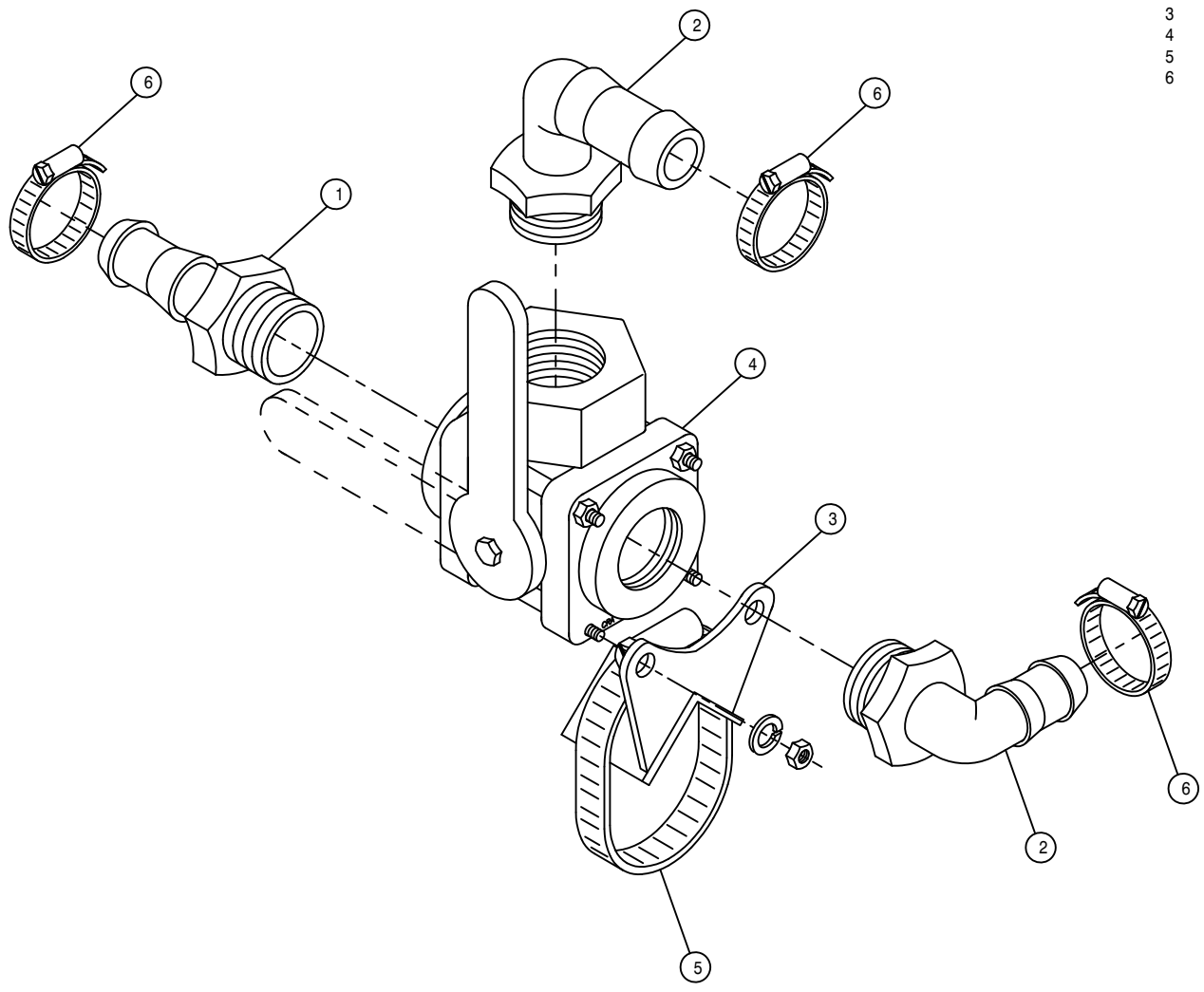

LEFT 3-WAY FOAMER VALVE ASSEMBLY

DET.	QTY	PART NO.	DESCRIPTION
1	1	500022	3/4NPT-3/4HOSE BARB, POLY
2	2	500054	3/4NPT-90-3/4 HOSE BARB, POLY
3	1	701191	1" SOLU VLV MT WLD
4	1	696003	BALL VLV,3/4NPT 3WAY-SIDE POLY
5	1	520085	HOSE CLAMP NO 24 STAINLESS
6	3	520055	HOSE CLAMP NO 12 STAINLESS

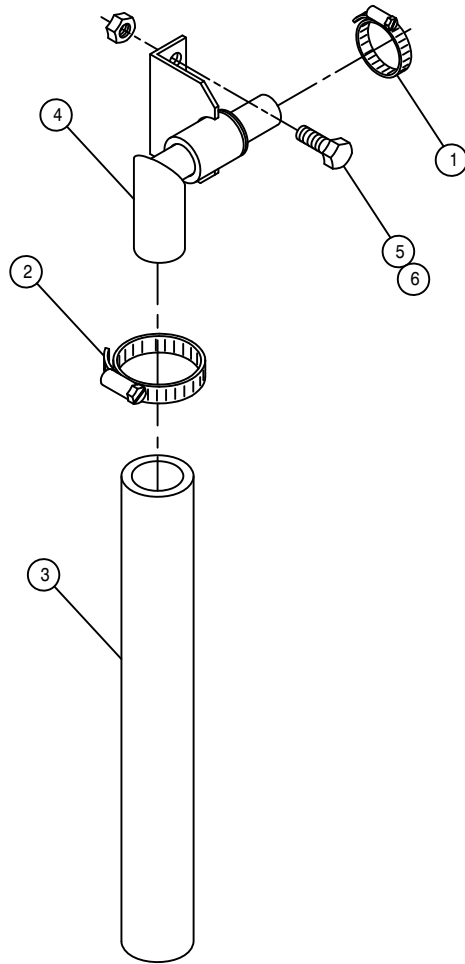

FOAMER DROP HOSE ASSEMBLY

DET.	QTY	PART NO.	DESCRIPTION
1	1	520055	HOSE CLAMP NO 12 STAINLESS
2	1	520085	HOSE CLAMP NO 24 STAINLESS
3	1	601367	HOSE, 1 1/4 X 24 2BR BLK EPDM
4	1	701194	FOAMER DROP HOSE SWIVEL WLD
5	2	900129	3/8UNC X 1" HEX BOLT
6	2	914004	3/8UNC HEX STOVER NUT

BOOM INDICATOR LIGHT ASSEMBLY

DET. QTY PART NO. DESCRIPTION

1	1	164503	BOOM INDICATOR LIGHT MT
2	7	293516	2-WIRE PIGTAIL ASSY
3	7	291713	MTG BRKT FOR 291710/291711
4	2	291711	YELLOW LAMP, 3 3/8" OVAL 12.8V
5	5	291710	RED LAMP, 3 3/8" OVAL 12.8V
6	14	903889	10-32 X 3/4 SLT RDHD MACH SCR
7	14	470175	10-32 HEX FLANGE LOCK NUT
8	2	470118	1/4UNC X 3/4 FLANGE HEX BOLT
9	2	470121	1/4UNC HEX FLANGE LOCK NUT

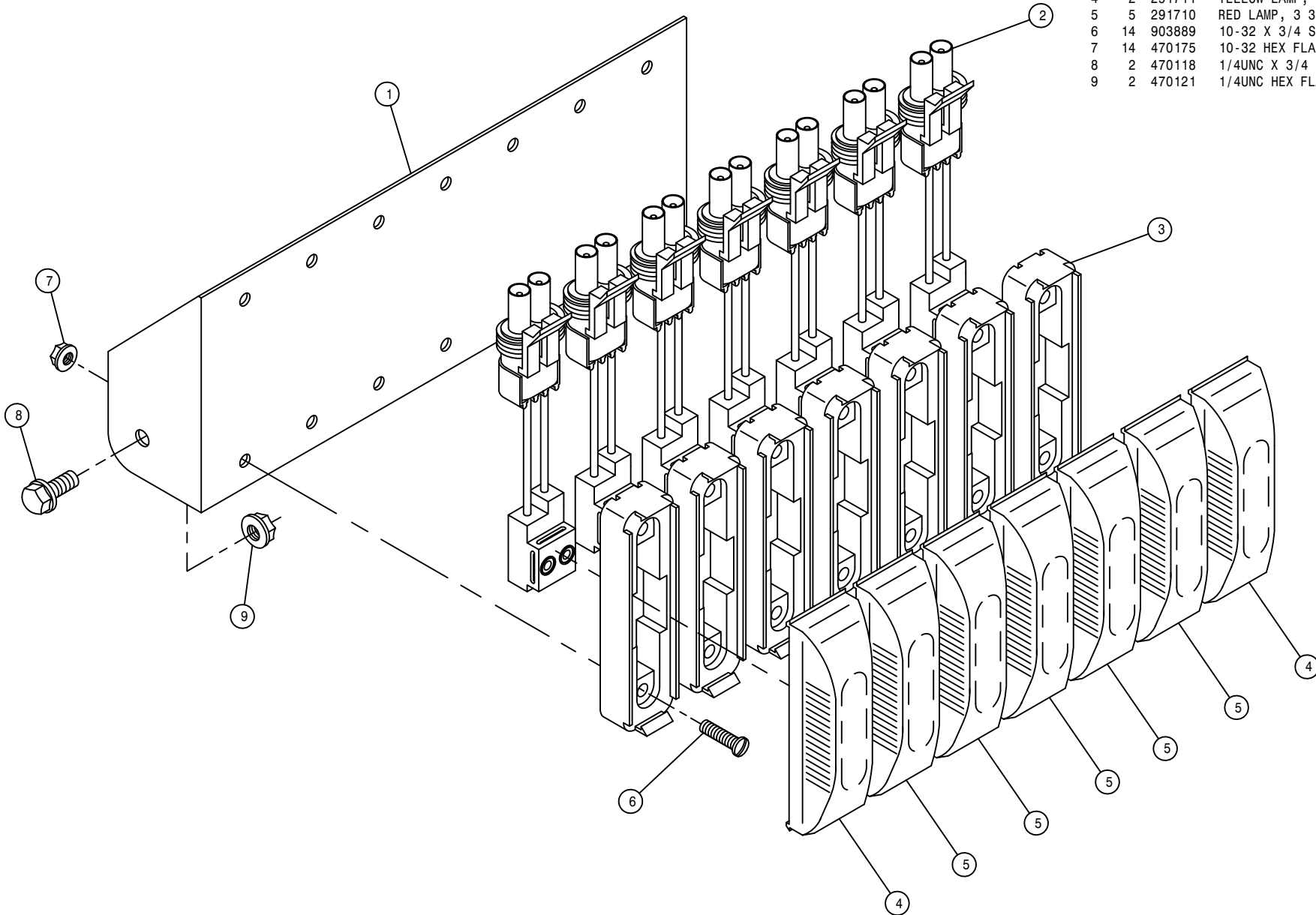

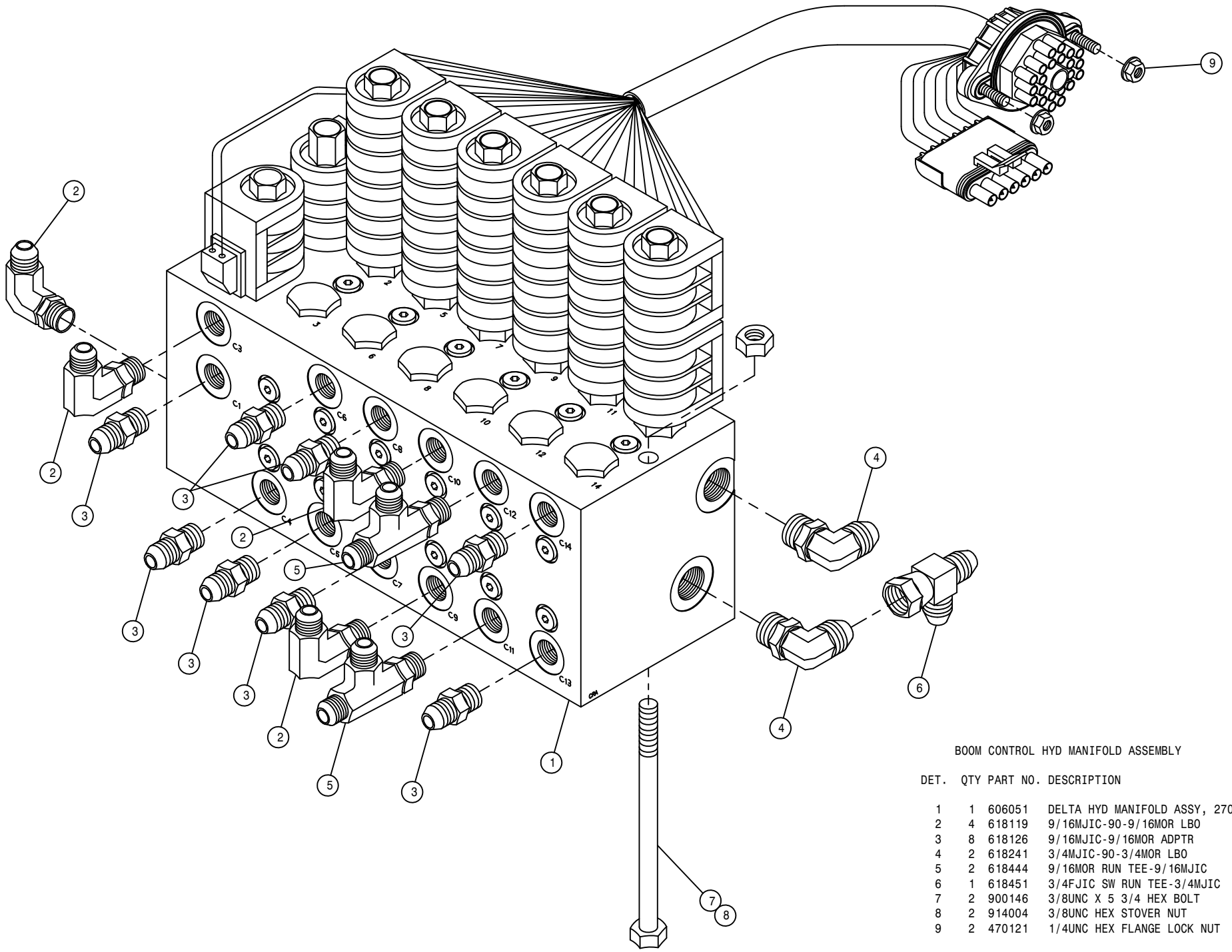

BOOM CONTROL HYD MANIFOLD ASSEMBLY

DET.	QTY	PART NO.	DESCRIPTION
1	1	606051	DELTA HYD MANIFOLD ASSY, 2703
2	4	618119	9/16MJIC-90-9/16MOR LBO
3	8	618126	9/16MJIC-9/16MOR ADPTR
4	2	618241	3/4MJIC-90-3/4MOR LBO
5	2	618444	9/16MOR RUN TEE-9/16MJIC
6	1	618451	3/4FJIC SW RUN TEE-3/4MJIC
7	2	900146	3/8UNC X 5 3/4 HEX BOLT
8	2	914004	3/8UNC HEX STOVER NUT
9	2	470121	1/4UNC HEX FLANGE LOCK NUT

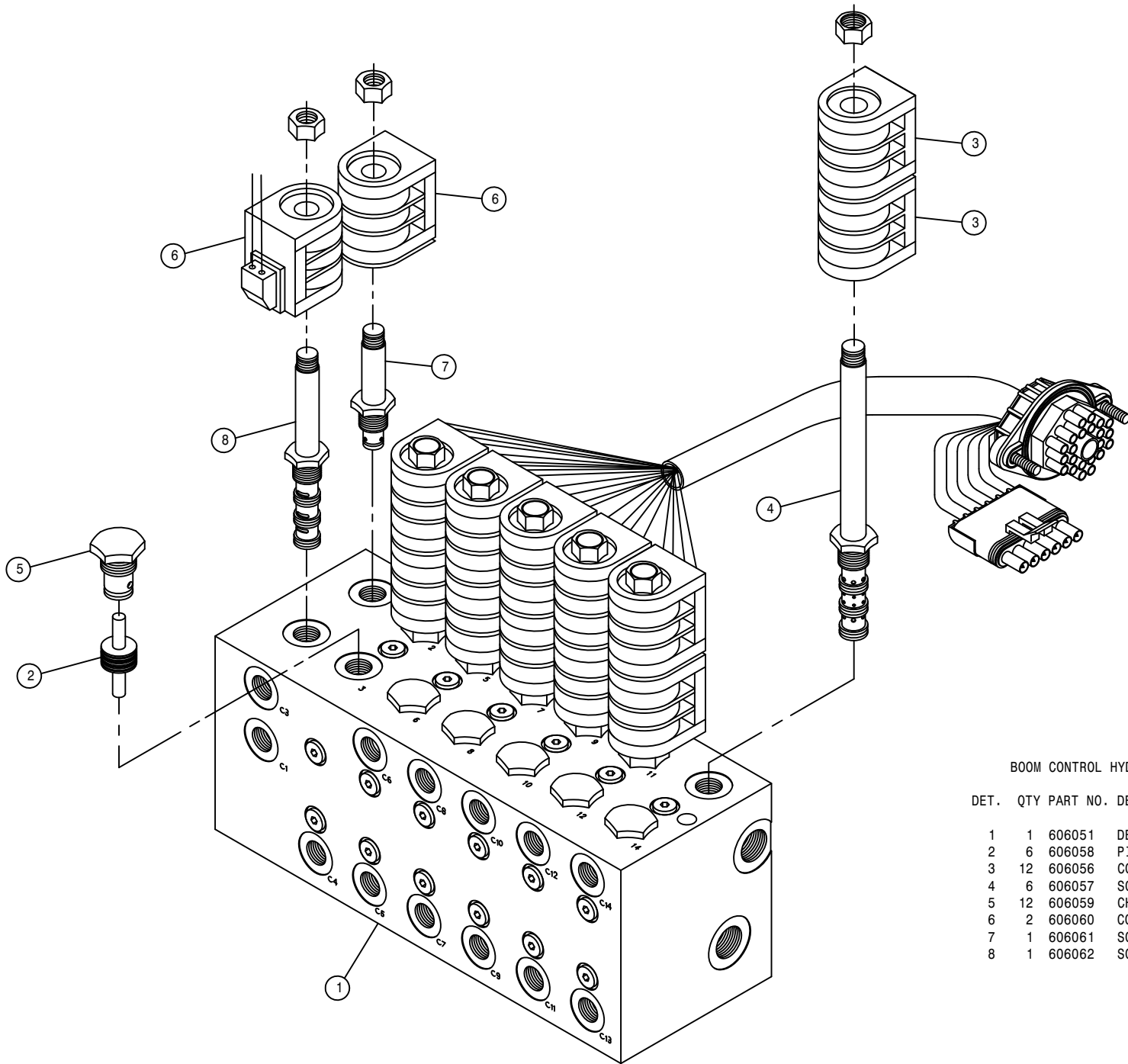

BOOM CONTROL HYD MANIFOLD ASSEMBLY

DET. QTY PART NO. DESCRIPTION

1	1	606051	DELTA HYD MANIFOLD ASSY, 2703
2	6	606058	PISTON ASSY FOR 606050
3	12	606056	COIL (63900502) FOR 606050/051
4	6	606057	SOLE VLV(DGS4M00)FOR 606050/51
5	12	606059	CHECK VALVE FOR 606050
6	2	606060	COIL(80028) FOR 606051
7	1	606061	SOLE VLV(DES2C00) FOR 606051
8	1	606062	SOLE VLV(DGS4B00) FOR 606051

LIFTARM ASSEMBLY

DET. QTY PART NO. DESCRIPTION

DET.	QTY	PART NO.	DESCRIPTION
1	15	470287	TUBE CLAMP, .375-.375 (PAIR)
2	12	900086	5/16UNC X 2 1/4 HEX BOLT
3	1	615761	LIFT RAISE HYD TUBE ASSY
4	1	615762	LIFT LOWER HYD TUBE ASSY
5	1	615764	LEVEL LOWER HYD TUBE ASSY
6	1	615763	LEVEL RAISE HYD TUBE ASSY
7	2	615765	BREAKAWAY HYD TUBE ASSY
8	1	615767	BOOM EXTN LOWER HYD TUBE ASSY
9	1	615766	BOOM EXTN RAISE HYD TUBE ASSY
10	1	615769	RH FOLD LOWER HYD TUBE ASSY
11	1	615768	RH FOLD RAISE HYD TUBE ASSY
12	2	618019	9/16MJIC UNION TEE
13	2	618618	9/16MJIC-90-9/16FJIC SWIV LBO
14	10	619010	9/16MJIC UNION
15	3	900016	1/4UNC X 4 1/2 HEX BOLT
16	16	900403	3/4UNC X 2" HEX BOLT
17	4	910012	3/4UNC HEX NUT
18	3	914000	1/4UNC HEX STOVER NUT
19	12	914012	3/4UNC HEX STOVER NUT
20	4	920506	3/4 LOCK WASHER
21	2	164424	QUICK ATTACH PLT WLD
22	12	164452	LIFT ARM MT PIVOT PIN,STS12 00
23	1	164432	UPPER LIFT ARM WLD
24	8	121107	LIFTARM BEARING, ORKOT
25	4	121109	LIFT CYL BRG, ORKOT
26	2	621060	BOOM LIFT CYL ASSY STS12
27	2	164450	LWR LIFTARM WLD
28	12	914002	5/16UNC HEX STOVER NUT

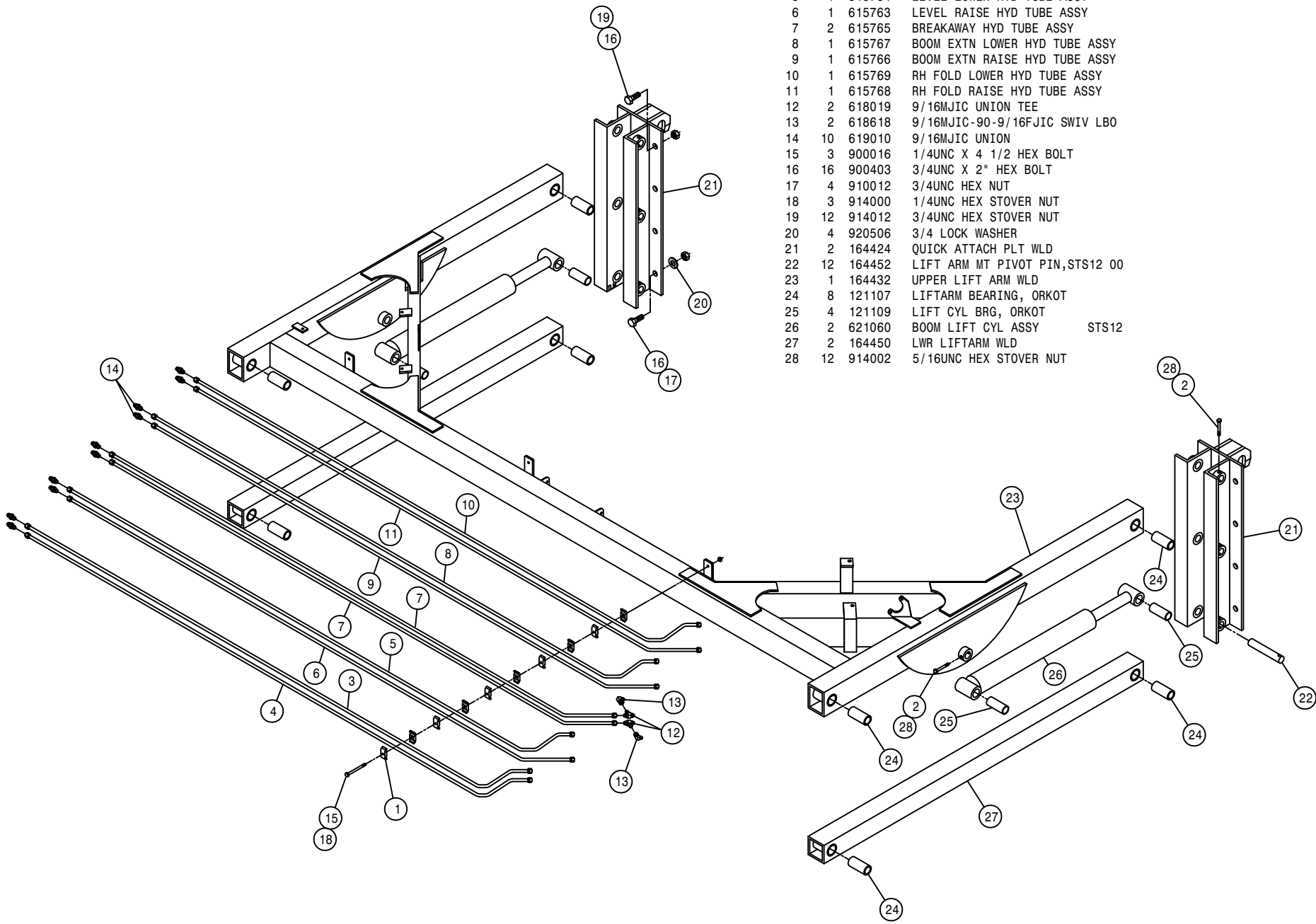

90

252090

TRANSOM ASSEMBLY

DET. QTY PART NO. DESCRIPTION

DET.	QTY	PART NO.	DESCRIPTION
1	4	470012	COTTER PIN 5/16 X 2" LG,316 SS
2	4	121029	JOURNAL BRG, 1.00 ID X 1.00 LG
3	4	470329	3/8UNC X 1 1/4 FLANGE HEX BOLT
4	16	473842	1/4UNC LOCK NUT,CNTR POINT SS
5	8	473979	.25UNC-1.12ID-1.50U-BOLT SQ SS
6	2	900284	1/2UNC X 4 3/4 HEX BOLT
7	2	914008	1/2UNC HEX STOVER NUT
8	1	164661	TRANSOM WLD STS12 2001
9	1	164469	RH TRANSOM PIVOT TUBE WLD
10	2	164481	INNER TRANSOM PIVOT TUBE
11	2	121103	TRANSOM PIVOT BRG, LWR ORKOT
12	1	164470	LH TRANSOM PIVOT TUBE WLD
13	4	121104	BOOM PIVOT BEARING, ORKOT
14	2	164482	TRANSOM PIVOT WASHER
15	6	164483	FOLD CYL STOP SPACER, 16 GA
16	2	164484	FOLD CYL STOP SPACER, .500
17	1	164485	HOSE SUPPORT WLD
18	2	164664	FOLD CYL TRUNION MT WLD 2001
19	2	164491	NOZL MT TUBE, TRANSOM STS12
20	2	121101	TRANSOM PIVOT BRG, TOP ORKOT
21	2	470326	ACCUMULATOR, DIAPHRAGM
22	2	618673	3/4MOR BRANCH TEE-9/16MJIC
23	8	914004	3/8UNC HEX STOVER NUT
24	2	164493	ACCUMULATOR MT WLD
25	2	164498	BOOM FOLD CYL PIN WLD
26	2	164496	LEVEL CYL PIN WLD, TRANSOM END
27	4	920008	1" SAE FLAT WASHER
28	2	621061	BOOM LEVEL CYL ASSY 3.00"STS12
29	2	621055	BOOM FOLD CYL ASSY STS12
30	8	900333	5/8UNC X 1 1/2 HEX BOLT
31	2	900129	3/8UNC X 1" HEX BOLT
32	2	900130	3/8UNC X 1 1/4 HEX BOLT
33	4	629727	FINISH PLUG FOR 1 IN X 16 GA
34	2	164641	BOOM PIVOT BRG SPACER STS12
35	2	164642	TRANSOM PIVOT BRG SPACER STS12
36	8	914010	5/8UNC HEX STOVER NUT

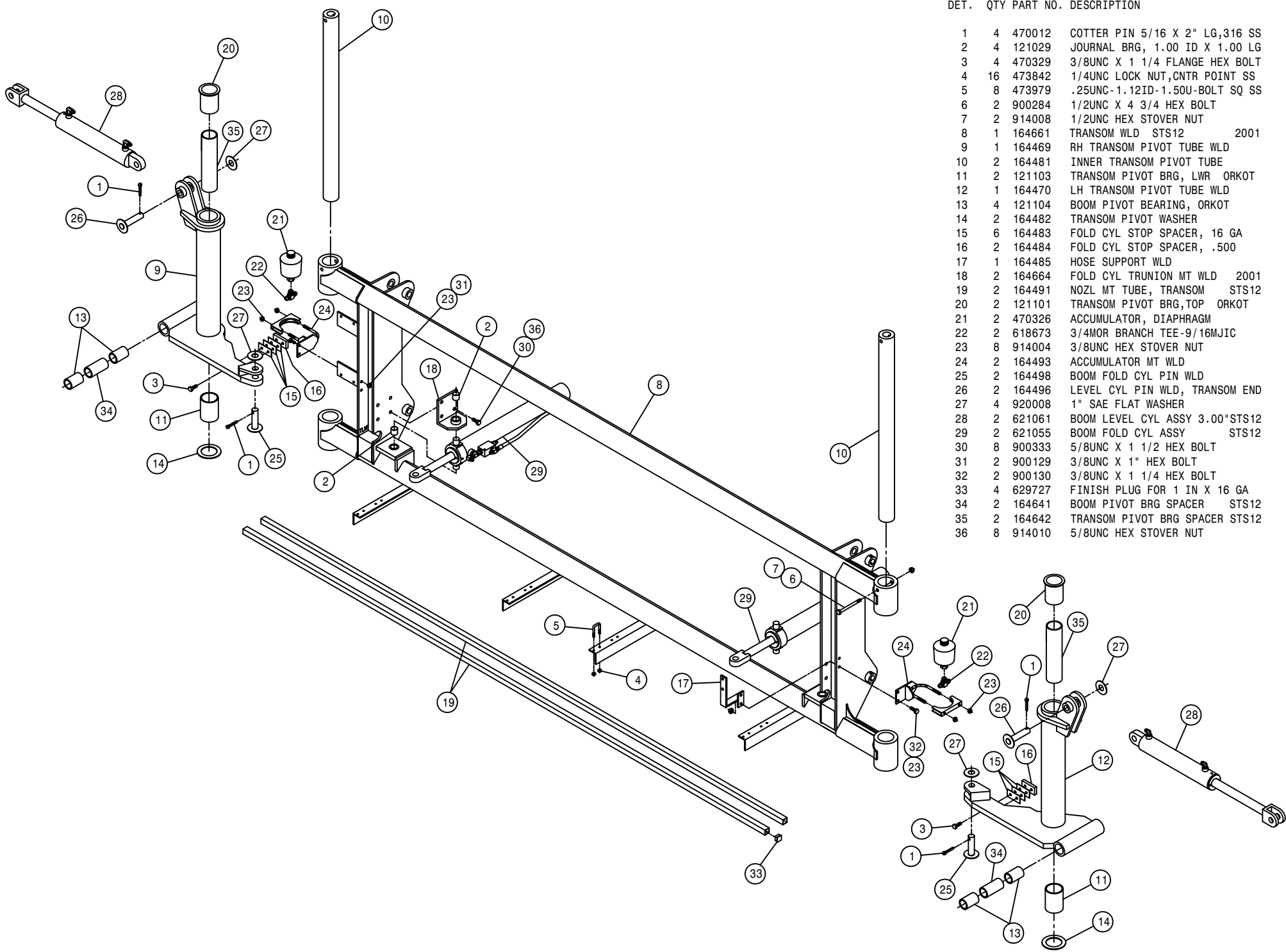

91

252091

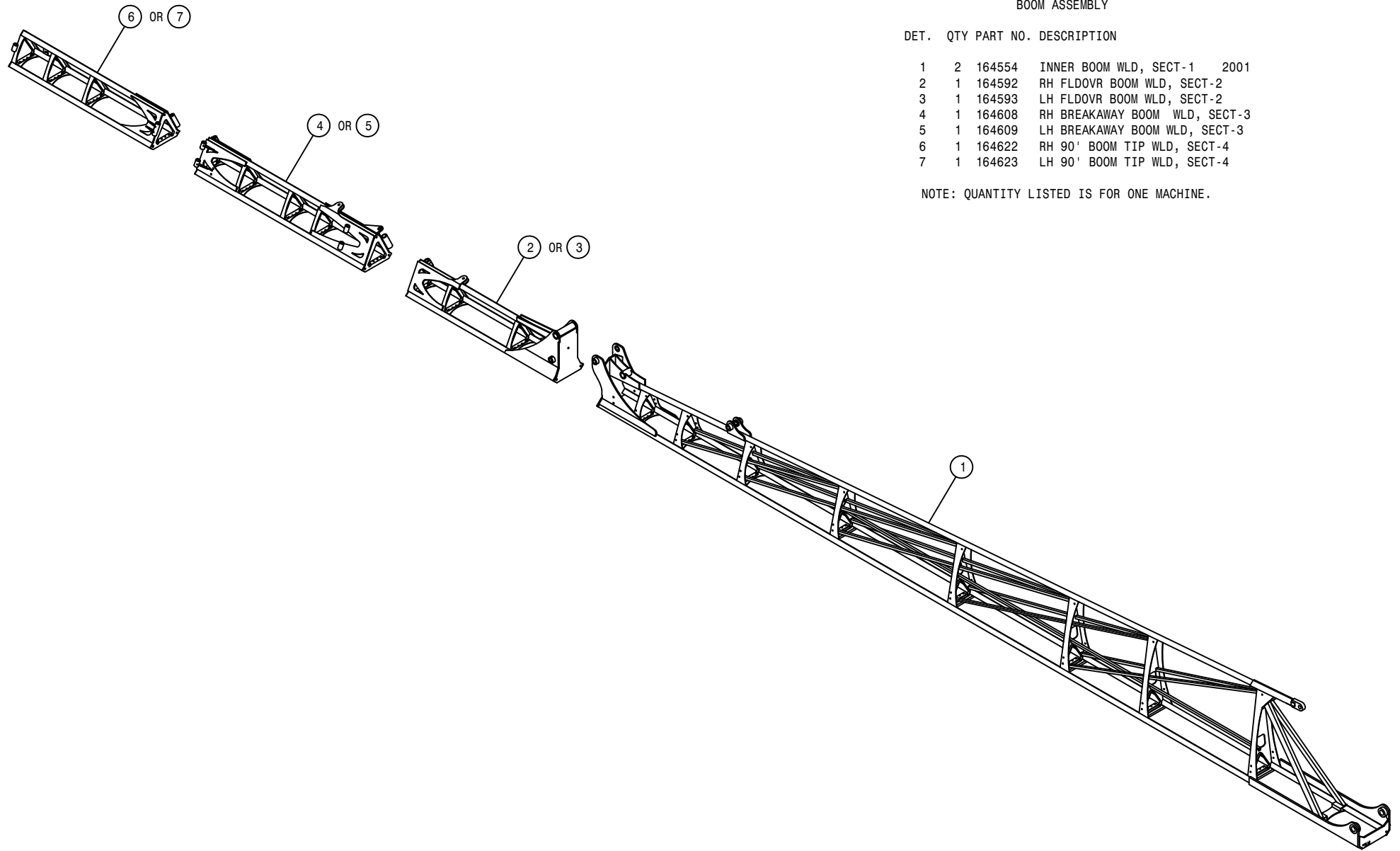

BOOM ASSEMBLY

DET. QTY PART NO. DESCRIPTION

1	2	164554	INNER BOOM WLD, SECT-1	2001
2	1	164592	RH FLDOVR BOOM WLD, SECT-2	
3	1	164593	LH FLDOVR BOOM WLD, SECT-2	
4	1	164608	RH BREAKAWAY BOOM WLD, SECT-3	
5	1	164609	LH BREAKAWAY BOOM WLD, SECT-3	
6	1	164622	RH 90' BOOM TIP WLD, SECT-4	
7	1	164623	LH 90' BOOM TIP WLD, SECT-4	

NOTE: QUANTITY LISTED IS FOR ONE MACHINE.

INNER BOOM ASSEMBLY

DET. QTY PART NO. DESCRIPTION

1	2	164554	INNER BOOM WLD, SECT-1	2001
2	28	470287	TUBE CLAMP, .375-.375	(PAIR)
3	36	473842	1/4UNC LOCK NUT,CNTR POINT SS	
4	18	473979	.25UNC-1.12ID-1.50U-BOLT SQ SS	
5	8	615760	BOOM HYD TUBE ASSY	
6	16	619010	9/16MJIC UNION	
7	4	629727	FINISH PLUG FOR 1 IN X 16 GA	
8	12	900007	1/4UNC X 2" HEX BOLT	
9	14	914000	1/4UNC HEX STOVER NUT	
10	2	164515	BOOM HINGE PIN WLD	
11	2	164547	NOZL MT TUBE, BOOM SECT-1 (A)	
12	2	164548	NOZL MT TUBE WLD, SECT-1 (B)	
13	2	164500	LEVEL CYL PIN WLD, SHAFT END	
14	2	900073	5/16UNC X 3 1/4 HEX BOLT	
15	2	470012	COTTER PIN 5/16 X 2" LG,316 SS	
16	2	914002	5/16UNC HEX STOVER NUT	
17	2	900027	1/4UNC X 5" HEX BOLT	
18	2	920008	1" SAE FLAT WASHER	

NOTE: QUANTITY LISTED IS FOR ONE MACHINE.

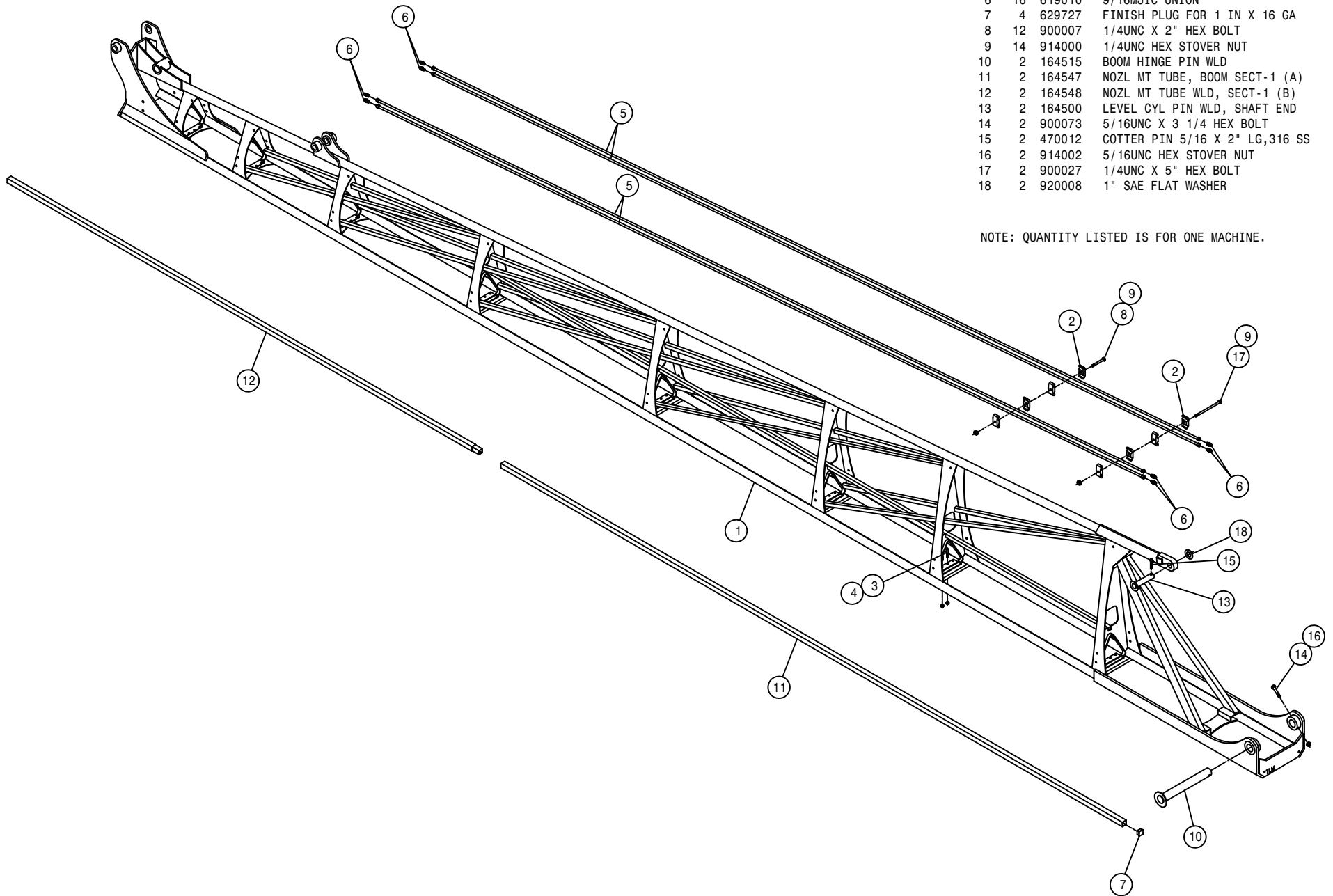

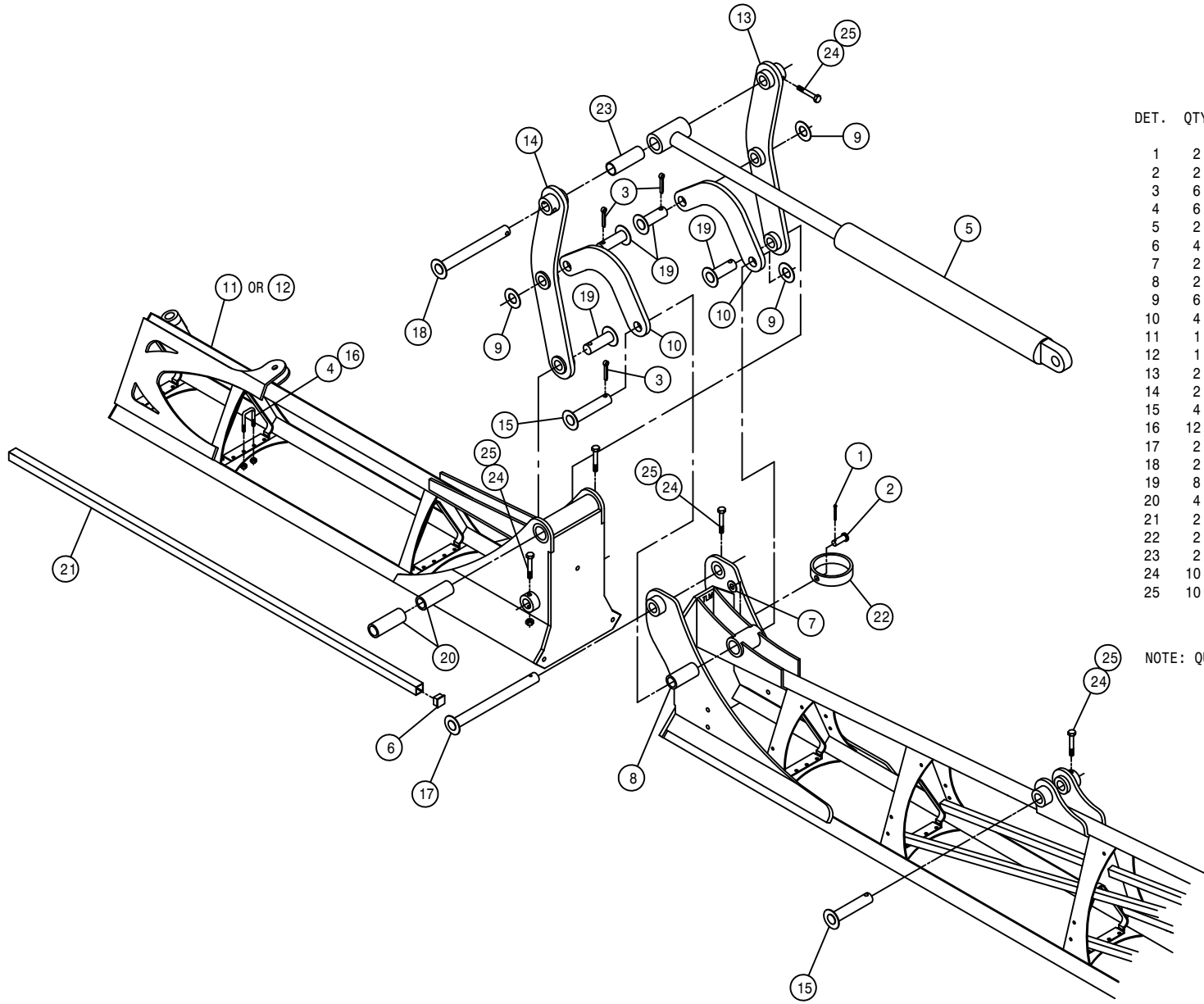

80' -90' BOOM HINGE ASSEMBLY

DET.	QTY	PART NO.	DESCRIPTION
1	2	390984	COTTER PIN 1/8 X 1 1/4
2	2	472277	CLEVIS PIN, .50 X 1.25LG PLT
3	6	470012	COTTER PIN 5/16 X 2" LG,316 SS
4	6	473979	.25UNC-1.12ID-1.50U-BOLT SQ SS
5	2	621056	OUTR BOOM FOLD CYL ASSY STS12
6	4	629727	FINISH PLUG FOR 1 IN X 16 GA
7	2	920004	1/2 SAE FLAT WASHER
8	2	121107	LIFTARM BEARING, ORKOT
9	6	920008	1" SAE FLAT WASHER
10	4	164643	XK402 TOP ARM(LEFT) 10.35 CNTR
11	1	164592	RH FLDOVR BOOM WLD, SECT-2
12	1	164593	LH FLDOVR BOOM WLD, SECT-2
13	2	164528	RH FOLD-OVER BOOMERANG WLD
14	2	164529	LH FOLD-OVER BOOMERANG WLD
15	4	164522	BOOM FOLD CYL PIN WLD
16	12	473842	1/4UNC LOCK NUT,CNTR POINT SS
17	2	164518	BOOM FOLD PIVOT PIN WLD
18	2	164520	BOOM CYL PIVOT PIN WLD
19	8	164524	BOOMERANG CNTR PIVOT PIN WLD
20	4	121106	BOOM FOLD BRG, ORKOT
21	2	164551	NOZL MT TUBE, BOOM SECT-2
22	2	164517	HOSE SUPPORT RING
23	2	121108	OUTR BOOM FOLD CYL BRG, ORKOT
24	10	900086	5/16UNC X 2 1/4 HEX BOLT
25	10	914002	5/16UNC HEX STOVER NUT

NOTE: QUANTITY LISTED IS FOR ONE MACHINE.

BOOM BREAKAWAY ASSEMBLY

DET. QTY PART NO. DESCRIPTION

DET.	QTY	PART NO.	DESCRIPTION
1	36	473842	1/4UNC LOCK NUT,CNTR POINT SS
2	18	473979	.25UNC-1.12ID-1.50U-BOLT SQ SS
3	6	470011	COTTER PIN 5/32 X 1 1/2,316 SS
4	2	621057	BOOM BREAKAWAY CYL ASSY STS12
5	8	629727	FINISH PLUG FOR 1 IN X 16 GA
6	1	164592	RH FLDOVR BOOM WLD, SECT-2
7	1	164593	LH FLDOVR BOOM WLD, SECT-2
8	1	164608	RH BREAKAWAY BOOM WLD, SECT-3
9	1	164609	LH BREAKAWAY BOOM WLD, SECT-3
10	1	164622	RH 90' BOOM TIP WLD, SECT-4
11	1	164623	LH 90' BOOM TIP WLD, SECT-4
12	4	164637	BOOM TIP SECTION PIN WLD
13	8	121110	BREAKAWAY BRG, ORKOT
14	2	164553	NOZL MT TUBE, BOOM SECT-4
15	2	164552	NOZL MT TUBE, BOOM SECT-3
16	2	900265	1/2UNC X 1 1/2 HEX BOLT
17	2	900267	1/2UNC X 2" HEX BOLT
18	4	914008	1/2UNC HEX STOVER NUT
19	2	164526	BOOM BREAKAWAY PIVOT PIN WLD

NOTE: QUANTITY LISTED IS FOR ONE MACHINE.

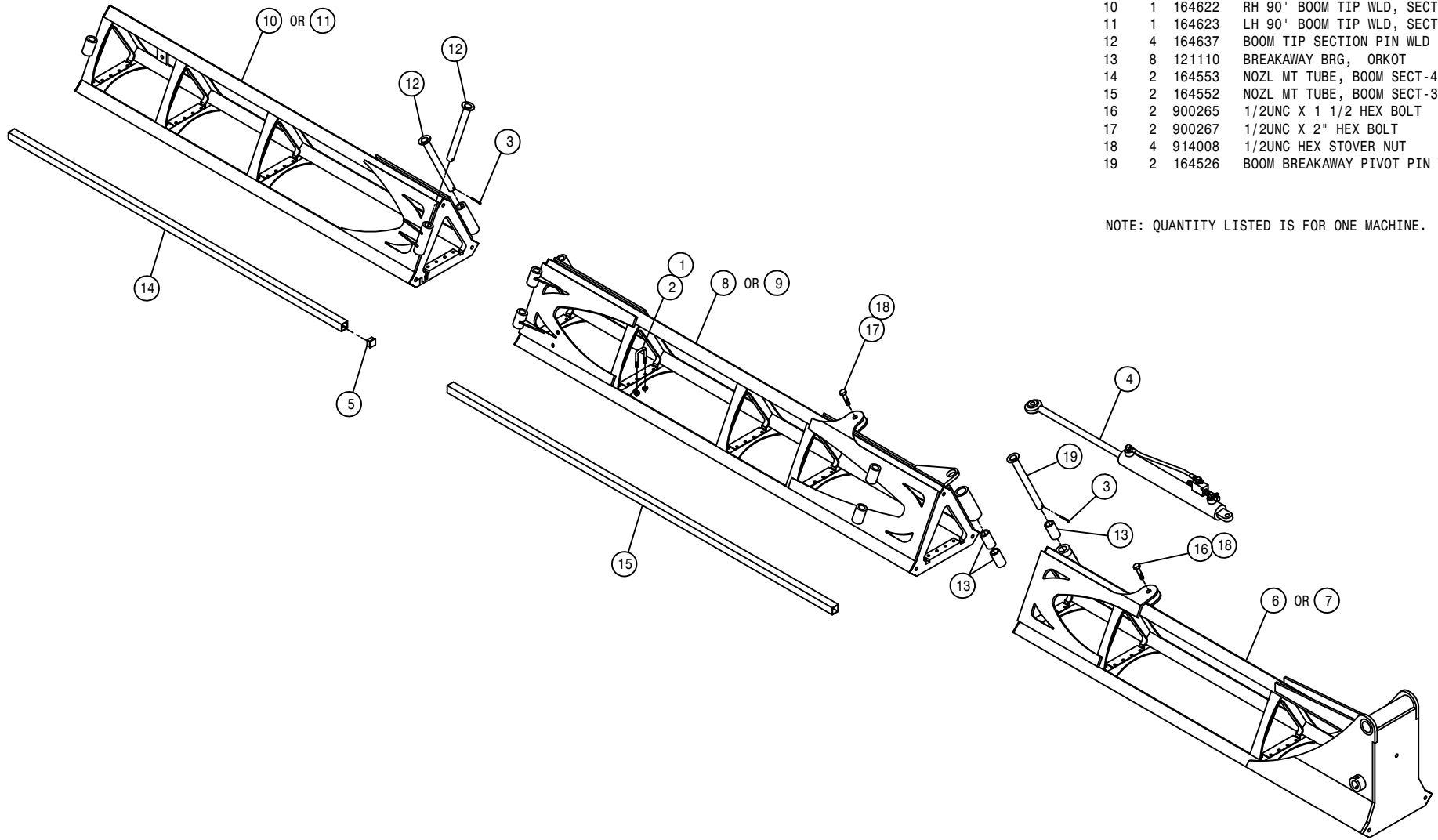

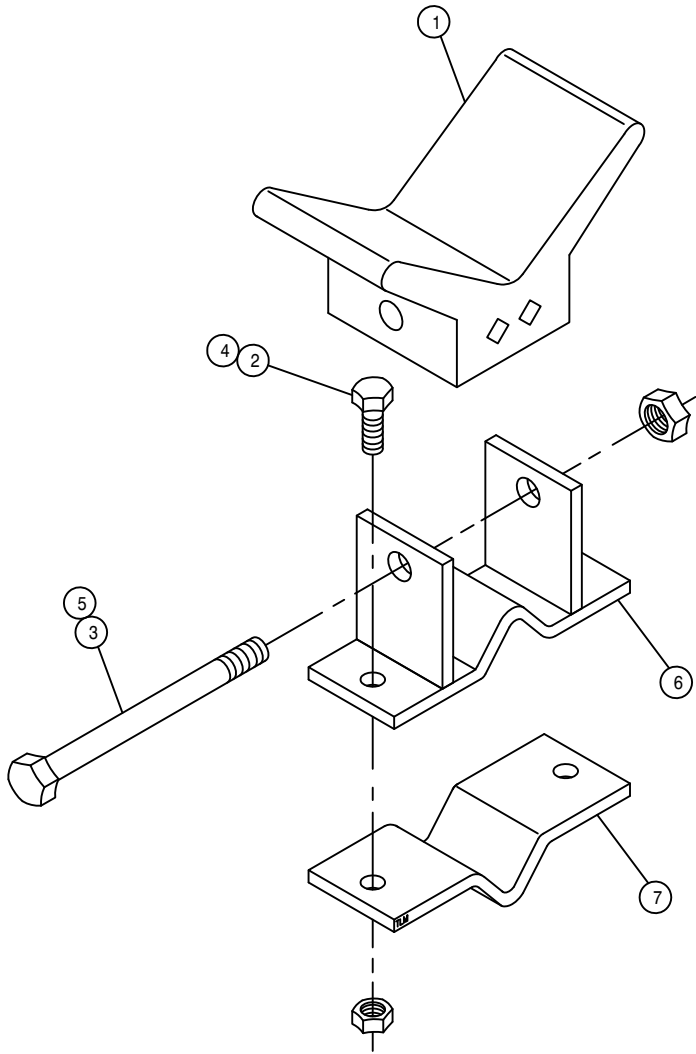

90' BOOM SUPPORT ASSEMBLY

DET.	QTY	PART NO.	DESCRIPTION
	1	470324	3" RUBBER BOW GUARD
	2	900130	3/8UNC X 1 1/4 HEX BOLT
	3	900273	1/2UNC X 3 3/4 HEX BOLT
	4	914004	3/8UNC HEX STOVER NUT
	5	914008	1/2UNC HEX STOVER NUT
	6	164544	FRT BOOM SUPPORT WLD, 90' BOOM
	7	164545	FRT BOOM SUPPORT MT

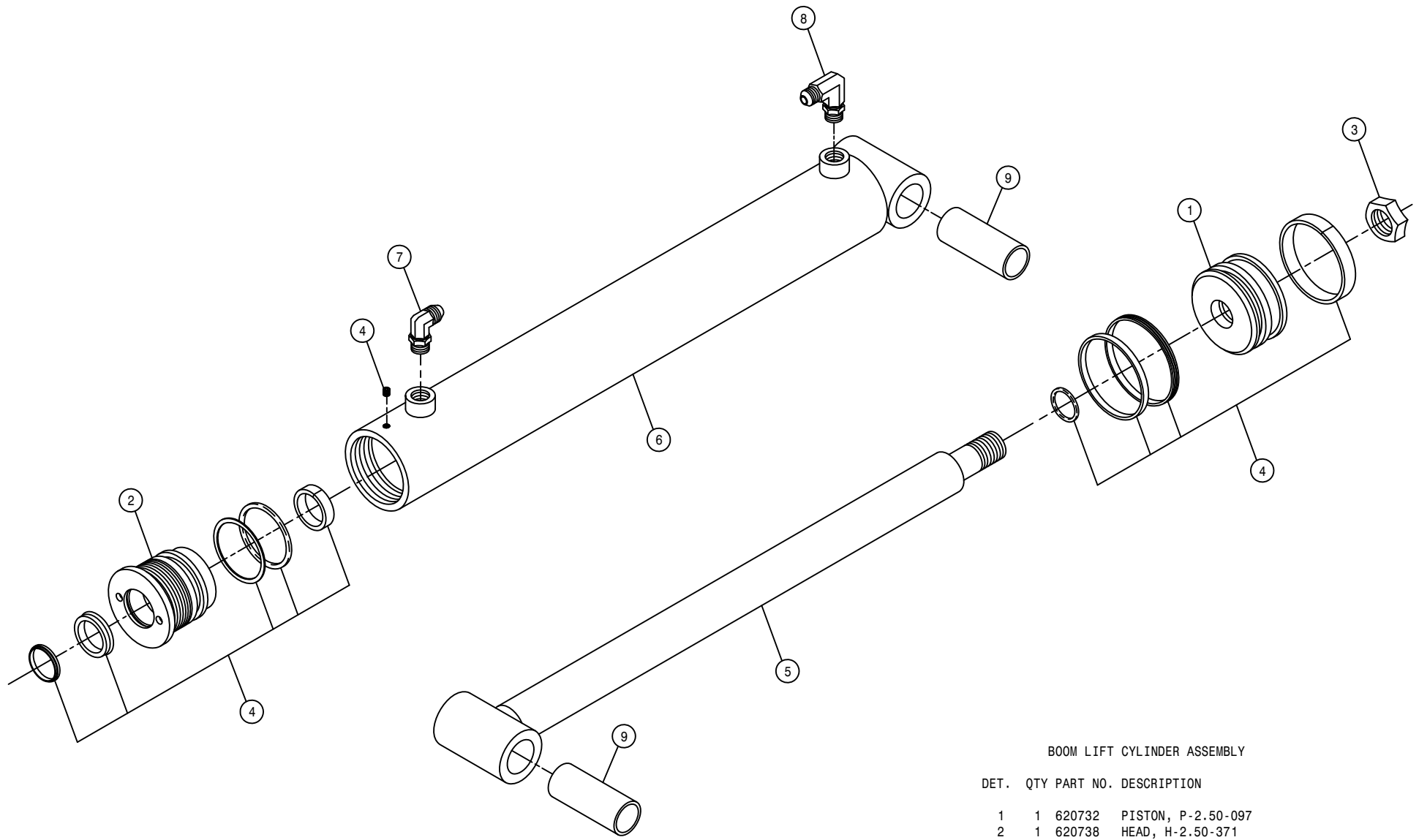

BOOM LIFT CYLINDER ASSEMBLY

DET.	QTY	PART NO.	DESCRIPTION
	1	620732	PISTON, P-2.50-097
	1	620738	HEAD, H-2.50-371
	1	620766	NUT, N-1.00-02
	1	620790	REPAIR KIT, HYD CYL, RK-2.50-806
	1	620928	SHAFT WLD, LIFT CYL 620925
	1	620929	BARREL WLD, LIFT CYL 620925
	1	618119	9/16MJIC-90-9/16MOR LBO
	1	618689	9/16MOR-90-9/16MJ .042 CHK VLV
	2	121109	LIFT CYL BRG, ORKOT

NOTE: 1. 620925 - BOOM LIFTARM CYLINDER ASSEMBLY ITEMS 1-6
 2. 621060 - BOOM LIFTARM CYLINDER ASSEMBLY WITH FITTINGS

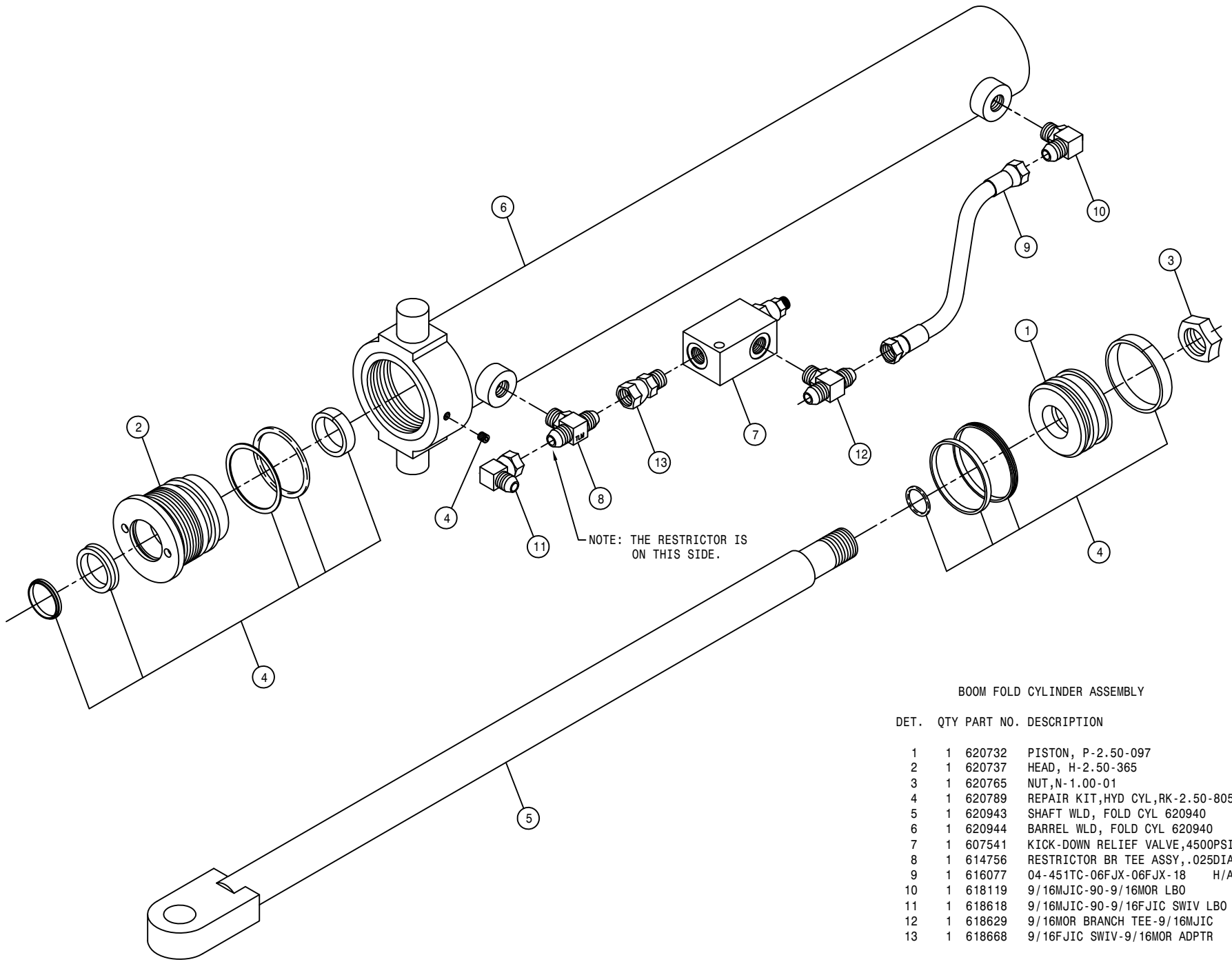

BOOM FOLD CYLINDER ASSEMBLY

DET.	QTY	PART NO.	DESCRIPTION
	1	620732	PISTON, P-2.50-097
	2	620737	HEAD, H-2.50-365
	3	620765	NUT, N-1.00-01
	4	620789	REPAIR KIT, HYD CYL, RK-2.50-805
	5	620943	SHAFT WLD, FOLD CYL 620940
	6	620944	BARREL WLD, FOLD CYL 620940
	7	607541	KICK-DOWN RELIEF VALVE, 4500PSI
	8	614756	RESTRICTOR BR TEE ASSY, .025DIA
	9	616077	04-451TC-06FJX-06FJX-18 H/A
	10	618119	9/16MJIC-90-9/16MOR LBO
	11	618618	9/16MJIC-90-9/16FJIC SWIV LBO
	12	618629	9/16MOR BRANCH TEE-9/16MJIC
	13	618668	9/16FJIC SWIV-9/16MOR ADPTR

NOTE: 1. 620940 - BOOM FOLD CYLINDER ASSEMBLY ITEMS 1-6
 2. 621055 - BOOM FOLD CYLINDER ASSEMBLY WITH FITTINGS

100

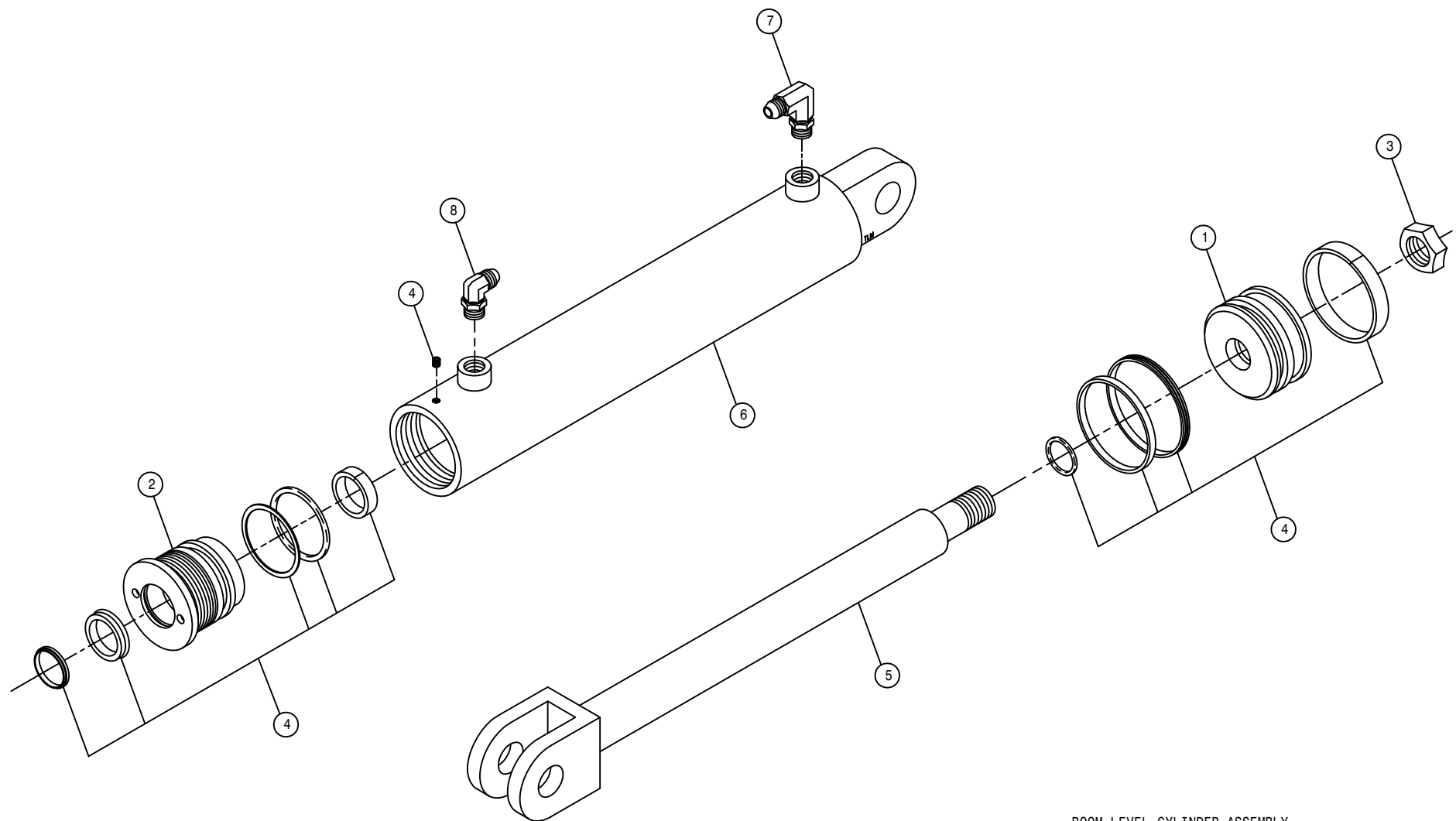

BOOM LEVEL CYLINDER ASSEMBLY

DET.	QTY	PART NO.	DESCRIPTION
	1	620734	PISTON, P-3.00-097
	1	620740	HEAD, H-3.00-325
	1	620765	NUT,N-1.00-01
	1	620792	REPAIR KIT,HYD CYL,RK-3.00-801
	1	620953	SHAFT WLD, LEV CYL 620950
	1	620954	BARREL WLD, LEV CYL 620950
	1	618119	9/16MJIC-90-9/16MOR LBO
	1	618689	9/16MOR-90-9/16MJ .042 CHK VLV

NOTE: 1. 620950 - BOOM LEVEL CYLINDER ASSEMBLY ITEMS 1-6
 2. 621061 - BOOM LEVEL CYLINDER ASSEMBLY WITH FITTINGS

252100

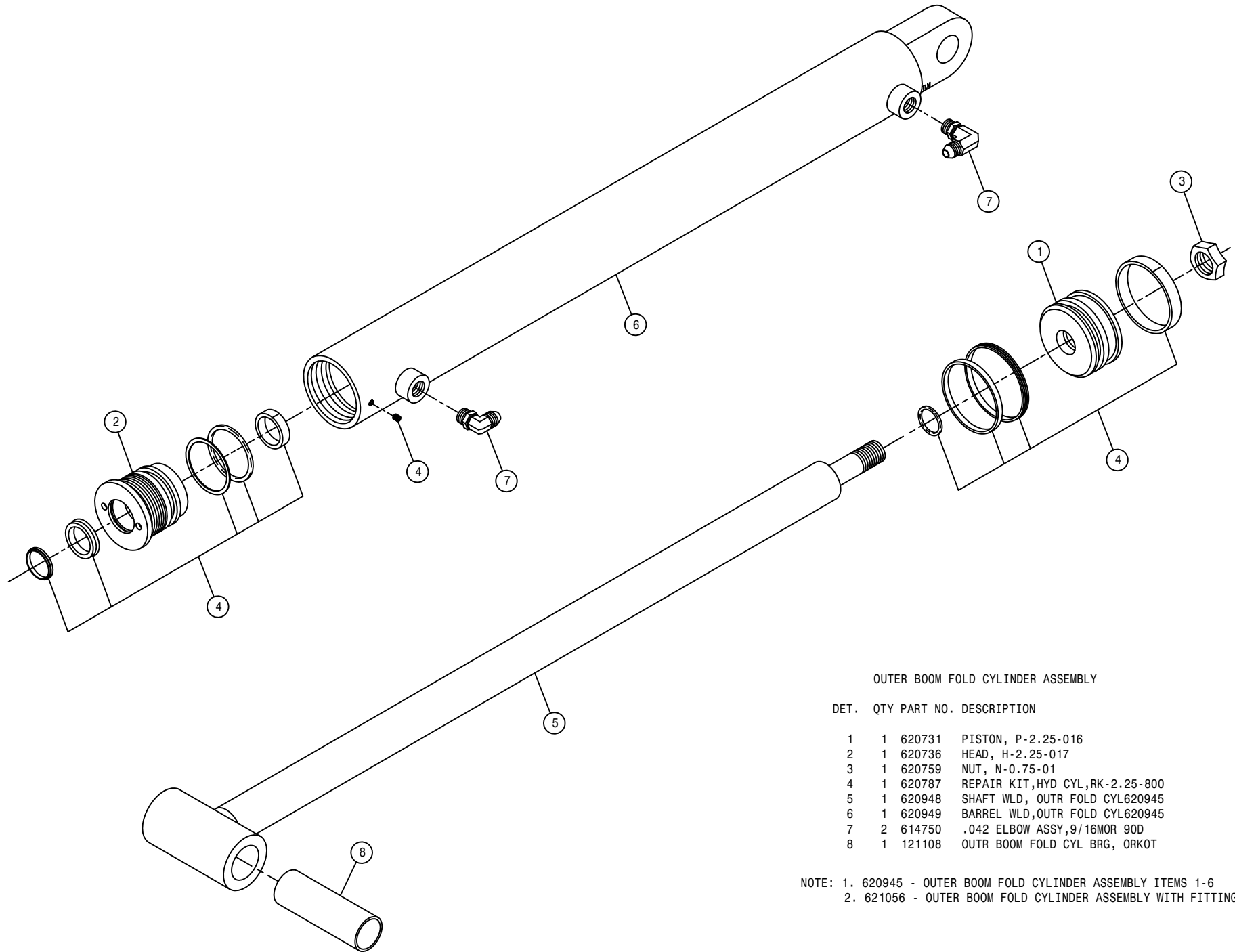

OUTER BOOM FOLD CYLINDER ASSEMBLY

DET.	QTY	PART NO.	DESCRIPTION
	1	620731	PISTON, P-2.25-016
	1	620736	HEAD, H-2.25-017
	1	620759	NUT, N-0.75-01
	1	620787	REPAIR KIT, HYD CYL, RK-2.25-800
	1	620948	SHAFT WLD, OUTR FOLD CYL 620945
	1	620949	BARREL WLD, OUTR FOLD CYL 620945
	2	614750	.042 ELBOW ASSY, 9/16 MOR 90D
	1	121108	OUTR BOOM FOLD CYL BRG, ORKOT

NOTE: 1. 620945 - OUTER BOOM FOLD CYLINDER ASSEMBLY ITEMS 1-6
 2. 621056 - OUTER BOOM FOLD CYLINDER ASSEMBLY WITH FITTINGS

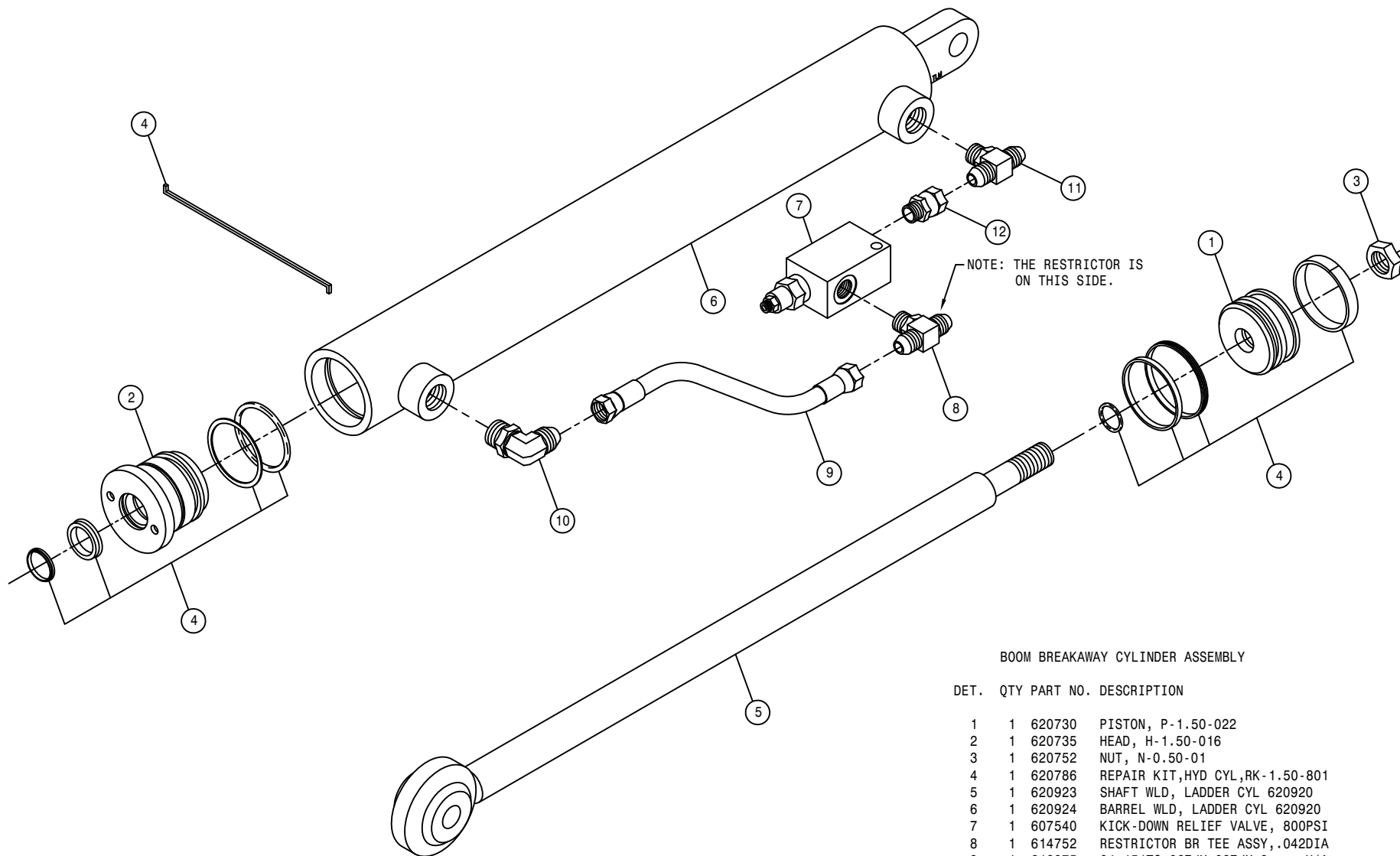

BOOM BREAKAWAY CYLINDER ASSEMBLY

DET. QTY PART NO. DESCRIPTION

DET.	QTY	PART NO.	DESCRIPTION
1	1	620730	PISTON, P-1.50-022
2	1	620735	HEAD, H-1.50-016
3	1	620752	NUT, N-0.50-01
4	1	620786	REPAIR KIT, HYD CYL, RK-1.50-801
5	1	620923	SHAFT WLD, LADDER CYL 620920
6	1	620924	BARREL WLD, LADDER CYL 620920
7	1	607540	KICK-DOWN RELIEF VALVE, 800PSI
8	1	614752	RESTRICTOR BR TEE ASSY, .042DIA
9	1	616075	04-451TC-06FJX-06FJX-9 H/A
10	1	618119	9/16MJIC-90-9/16MOR LBO
11	1	618629	9/16MOR BRANCH TEE-9/16MJIC
12	1	618668	9/16FJIC SWIV-9/16MOR ADPTR

NOTE: 1. 620920 - BOOM BREAKAWAY CYLINDER ASSEMBLY ITEMS 1-6
 2. 621057 - BOOM BREAKAWAY CYLINDER ASSEMBLY WITH FITTINGS

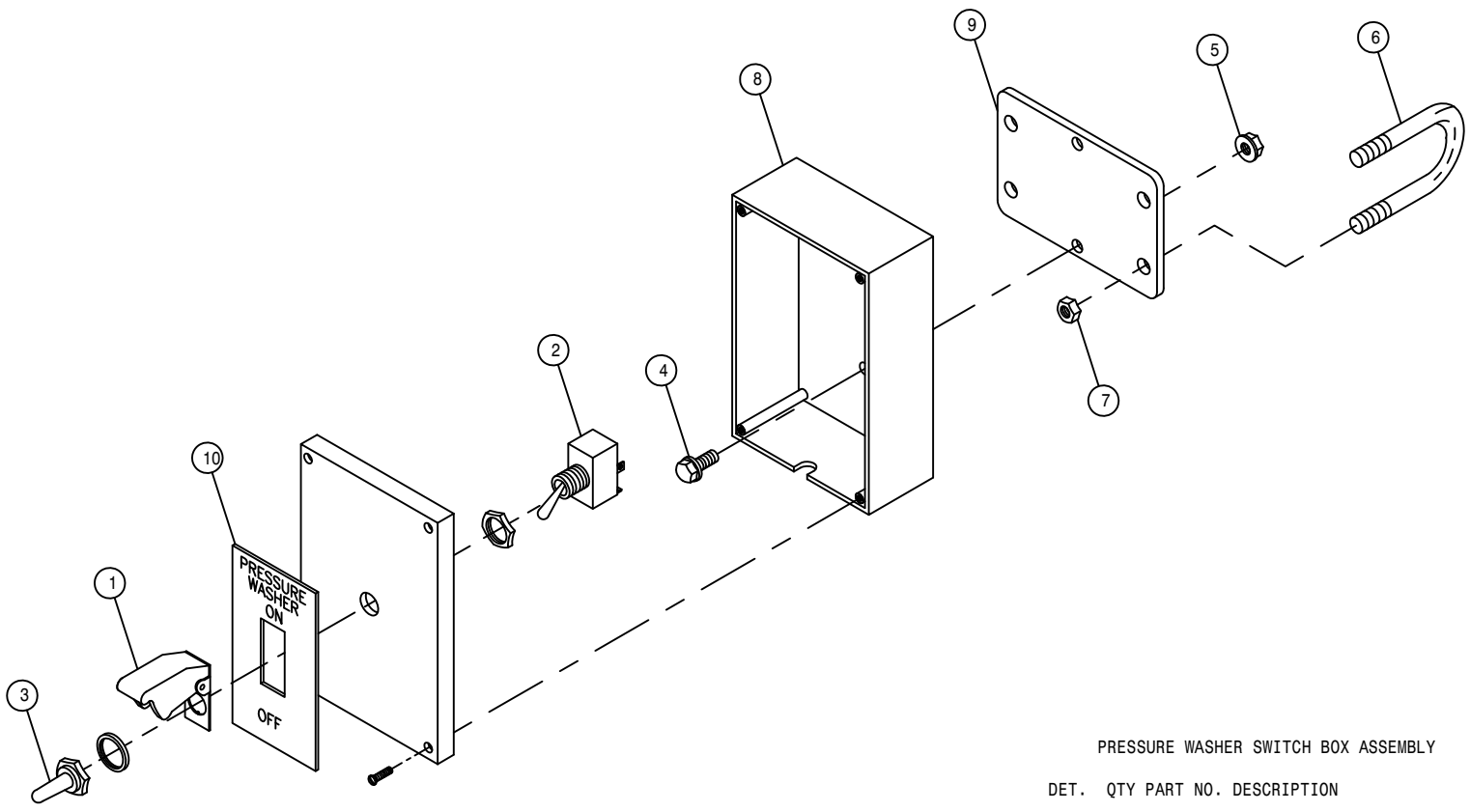

PRESSURE WASHER SWITCH BOX ASSEMBLY

DET.	QTY	PART NO.	DESCRIPTION
	1	291655	AIRCRAFT TOGGLE SWITCH GUARD
	1	291790	TOGGLE SWITCH, ON-OFF DPDT
	1	470001	RUBBER BOOT W NUT FOR 298012
	2	470118	1/4UNC X 3/4 FLANGE HEX BOLT
	2	470121	1/4UNC HEX FLANGE LOCK NUT
	2	473911	5/16UNC-1.31ID-2.00 U-BOLT
	4	910002	5/16UNC HEX NUT
	1	690738	PRESSURE WASHER SWITCH BOX
	1	690739	PRESSURE WASHER SWITCH BOX MT
	1	650110	DECAL,PRESSURE WASH CTRL,STS12

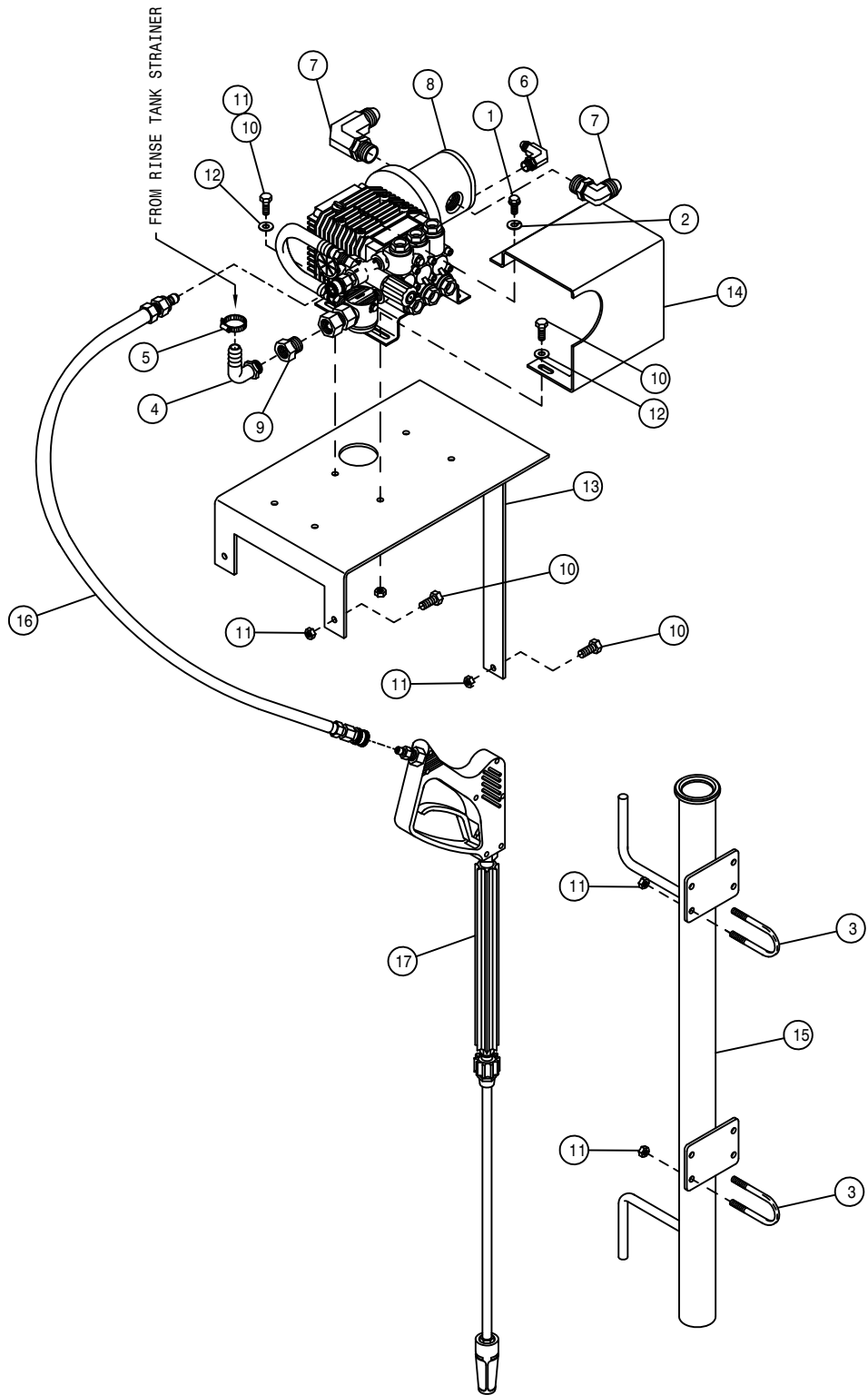

PRESSURE WASHER ASSEMBLY

DET. QTY PART NO. DESCRIPTION

1	2	473803	8MM-1.25 X 16MM HEX BOLT
2	2	473804	8MM LOCK WASHER
3	4	473911	5/16UNC-1.31ID-2.00 U-BOLT
4	1	500026	3/4NPT-90-1"HOSE BARB, POLY
5	1	520090	HOSE CLAMP NO 16 STAINLESS
6	1	618119	9/16MJIC-90-9/16MOR LBO
7	2	618474	3/4MJIC-90-1 1/16MOR LBO
8	1	690672	PRESSURE WASHER,PACE 320 HYD
9	1	715449	3/4FNPT X 3/4MGHT ADPTR BRS
10	7	900064	5/16UNC X 3/4 HEX BOLT
11	15	914002	5/16UNC HEX STOVER NUT
12	4	920001	5/16 SAE FLAT WASHER
13	1	690747	PRESSURE WASHER MT WLD
14	1	690736	PRESSURE WASHER SHIELD
15	1	690732	PRESSURE WASHER WAND MT WLD
16	1	690791	HOSE, PRESSURE WASHER 690672
17	1	690673	TRIGGER GUN ASSY FOR 690672

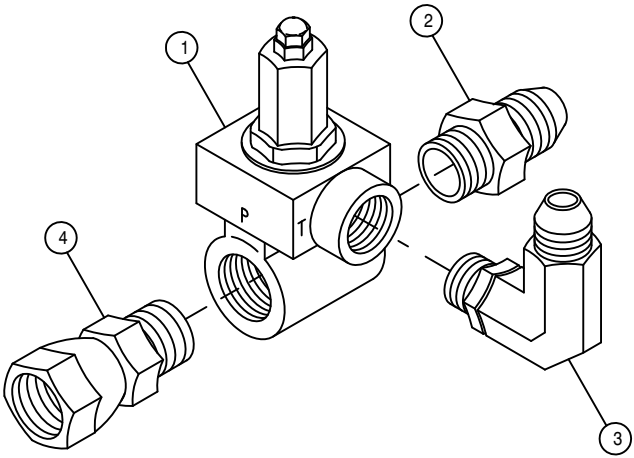

IN-LINE HYD RELIEF VALVE ASSEMBLY

DET. QTY PART NO. DESCRIPTION

1	1	607550	IN-LINE RELIEF VALVE, 2600 PSI
2	1	611127	1 1/16MJIC-1 1/16MOR ADPTR
3	1	618279	1 1/16MJIC-90-7/8MOR LBO
4	1	618578	1 1/16FJIC SWIV-1 1/16MOR

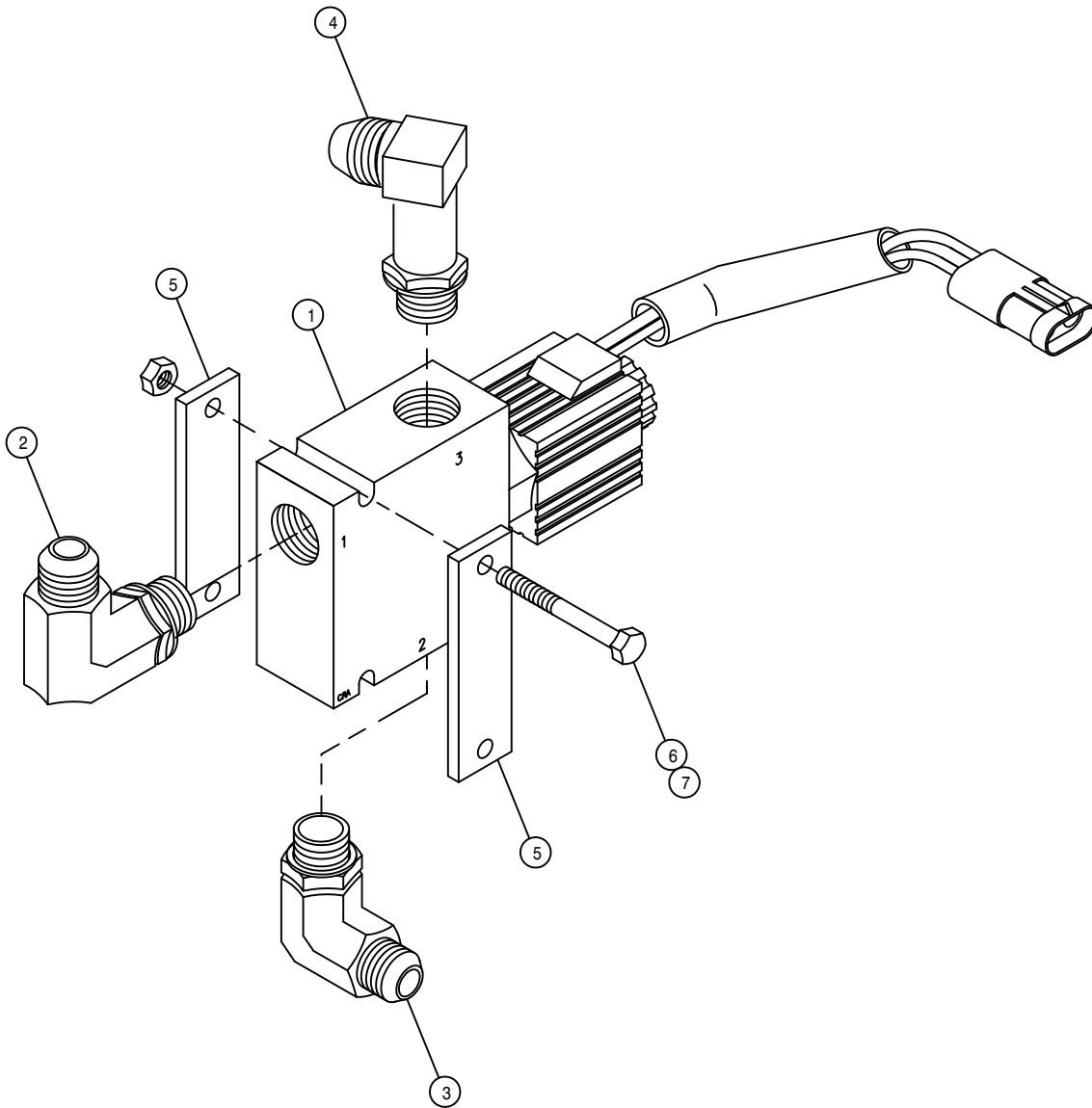

PRESSURE WASHER HYDRAULIC VALVE ASSEMBLY

DET. QTY PART NO. DESCRIPTION

1	1	606015	SIDE-FILL/WASH VLV W/SHRD ASSY
2	1	618248	1 1/16MJIC-90-1 1/16MOR LBO
3	1	618474	3/4MJIC-90-1 1/16MOR LBO
4	1	618674	1 1/16MJIC-90-1 1/16MOR XL LBO
5	2	690728	VALVE KEEPER/SPACER
6	2	900072	5/16UNC X 3" HEX BOLT
7	2	914002	5/16UNC HEX STOVER NUT

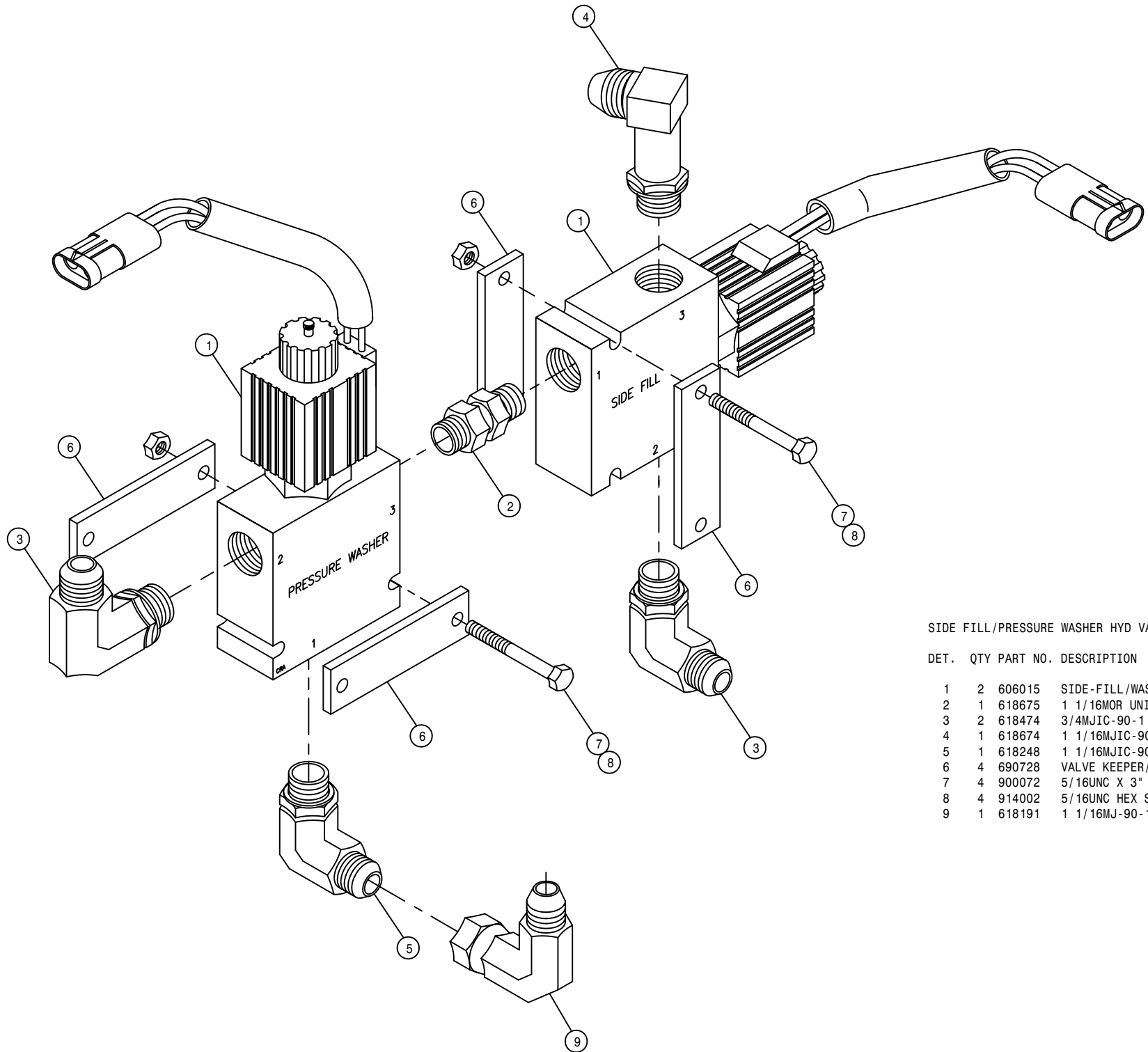

SIDE FILL/PRESSURE WASHER HYD VALVE ASSEMBLY

DET.	QTY	PART NO.	DESCRIPTION
1	2	606015	SIDE-FILL/WASH VLV W/SHRD ASSY
2	1	618675	1 1/16MOR UNION
3	2	618474	3/4MJIC-90-1 1/16MOR LBO
4	1	618674	1 1/16MJIC-90-1 1/16MOR XL LBO
5	1	618248	1 1/16MJIC-90-1 1/16MOR LBO
6	4	690728	VALVE KEEPER/SPACER
7	4	900072	5/16UNC X 3" HEX BOLT
8	4	914002	5/16UNC HEX STOVER NUT
9	1	618191	1 1/16MJ-90-1 1/16FJ SWIV LBO

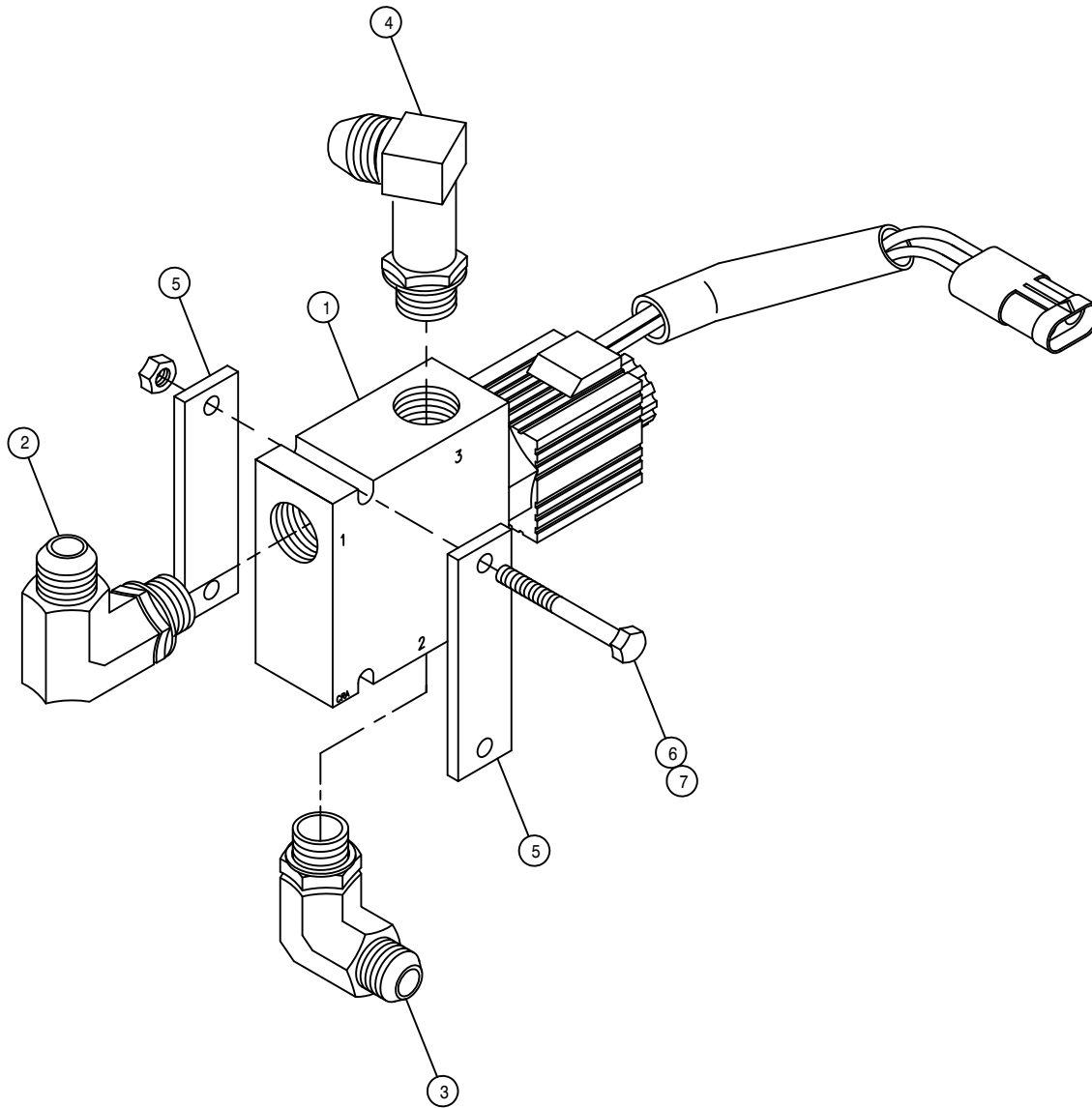

SIDE FILL HYDRAULIC VALVE ASSEMBLY

DET. QTY PART NO. DESCRIPTION

1	1	606015	SIDE-FILL/WASH VLV W/SHRD ASSY
2	1	618248	1 1/16MJIC-90-1 1/16MOR LBO
3	1	618474	3/4MJIC-90-1 1/16MOR LBO
4	1	618674	1 1/16MJIC-90-1 1/16MOR XL LBO
5	2	690728	VALVE KEEPER/SPACER
6	2	900072	5/16UNC X 3" HEX BOLT
7	2	914002	5/16UNC HEX STOVER NUT

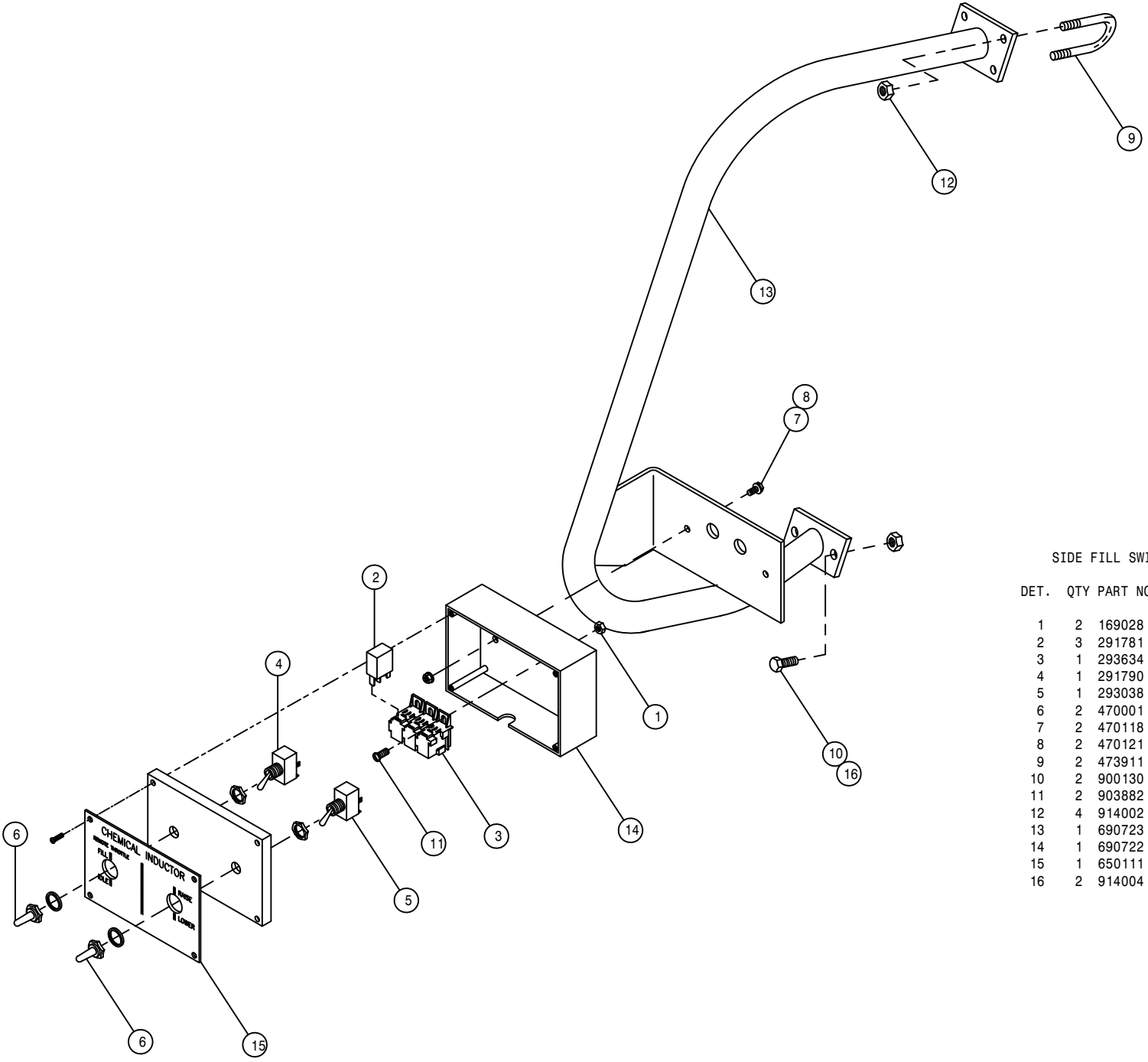

SIDE FILL SWITCH BOX ASSEMBLY

DET.	QTY	PART NO.	DESCRIPTION
	1	2	169028 10-24 HEX FLANGE LOCK NUT
	2	3	291781 MICRO RELAY, BOSCH 12V SPDT
	3	1	293634 SIDE FILL BOX HARNESS
	4	1	291790 TOGGLE SWITCH, ON-OFF DPDT
	5	1	293038 TOGGLE SWITCH DPDT 15 AMP
	6	2	470001 RUBBER BOOT W NUT FOR 298012
	7	2	470118 1/4UNC X 3/4 FLANGE HEX BOLT
	8	2	470121 1/4UNC HEX FLANGE LOCK NUT
	9	2	473911 5/16UNC-1.31ID-2.00 U-BOLT
	10	2	900130 3/8UNC X 1 1/4 HEX BOLT
	11	2	903882 10-24 X 1/2 SLT RDHD MACH SCR
	12	4	914002 5/16UNC HEX STOVER NUT
	13	1	690723 CHEM IND GUARD WLD
	14	1	690722 SIDE FILL SWITCH BOX
	15	1	650111 DECAL,CHEM INDUCTOR CTRL.STS12
	16	2	914004 3/8UNC HEX STOVER NUT

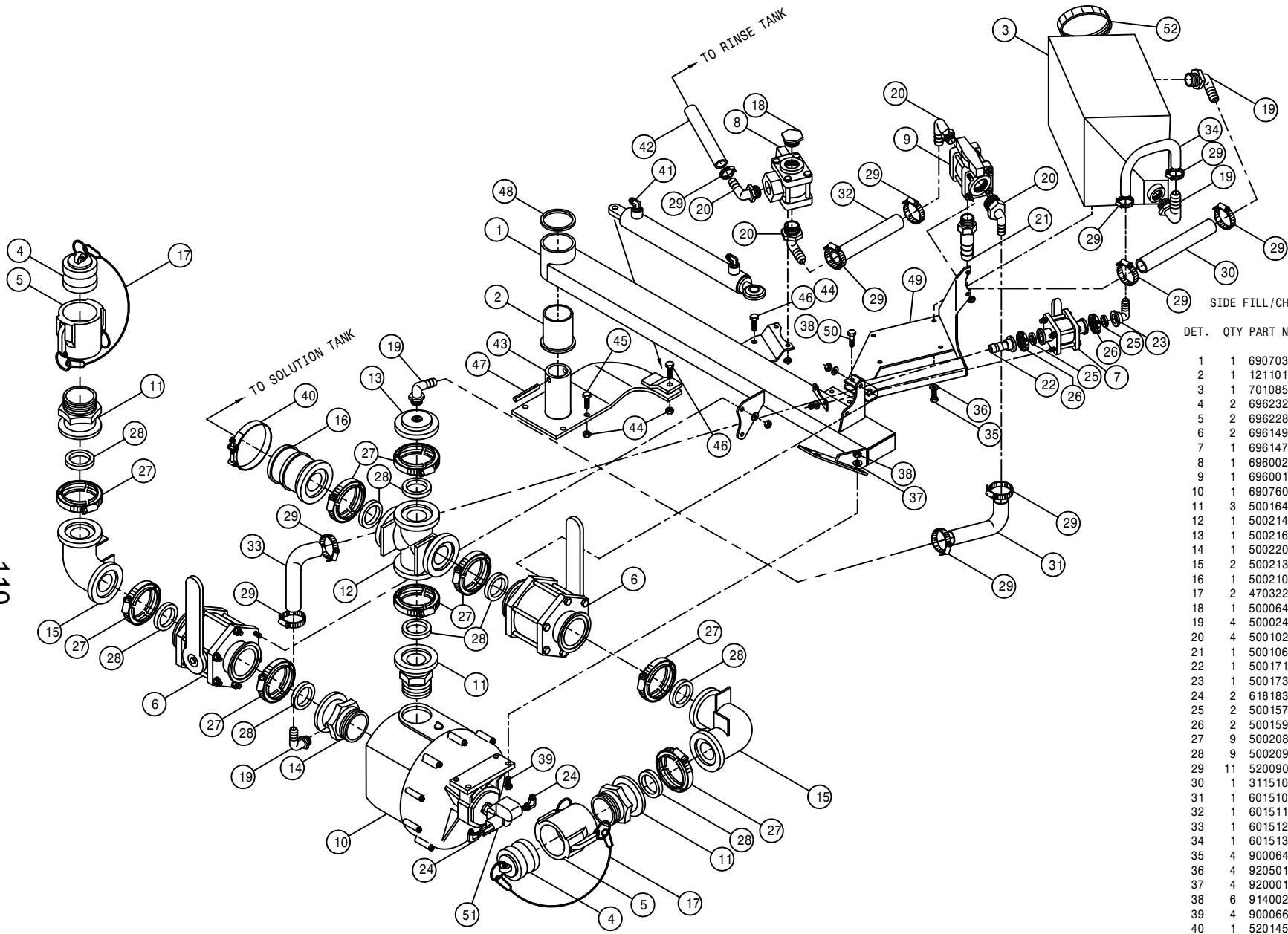

SIDE FILL/CHEMICAL INDUCTOR ASSEMBLY

DET.	QTY	PART NO.	DESCRIPTION
1	1	690703	SIDE FILL ARM WLD 2000
2	1	121101	TRANSOM PIVOT BRG,TOP ORKOT
3	1	701085	TANK, 5 GAL, SQ WHITE
4	2	696232	PLUG FOR 3.00 FEMALE COUPLER
5	2	696228	3.00FNPT-FEMALE COUPLER POLY
6	2	696149	BALL VLV, 3" FLANGE
7	1	696147	BALL VLV, 1" FLANGE
8	1	696002	BALL VLV,1.25NP 3WAY-SIDE POLY
9	1	696001	BALL VLV,1.25NP 3WAY-BOTT POLY
10	1	690760	BANJO PUMP,3" SIDE FILL STS12
11	3	500164	3" FLANGE-3" MNPT ADPTR POLY
12	1	500214	3"FP FLANGE CROSS
13	1	500216	3"FLANGE PLUG W/1"FNPT POLY
14	1	500220	3"FLANGE-3"MNPT W/1"FNPT POLY
15	2	500213	3"FLANGE-90-3"FLANGE LBO POLY
16	1	500210	3" FLANGE-3" HOSE BARB POLY
17	2	470322	LANYARD, 8" NYLON LOOP/LOOP
18	1	500064	1 1/4"NPT PIPE PLUG, POLY
19	4	500024	1"NPT-90-1"HOSE BARB, POLY
20	4	500102	1 1/4NPT-90-1" HOSE BARB POLY
21	1	500106	1 1/4NPT-1" HOSE BARB POLY
22	1	500171	1" FLANGE-1" HOSE BARB POLY
23	1	500173	1" FLANGE-90-1" HOSE BARB POLY
24	2	618183	3/4MJIC-90-7/8MOR LBO
25	2	500157	1" FLANGE GASKET EPDM
26	2	500159	1" FLANGE CLAMP, S.S.
27	9	500208	3" FLANGE CLAMP, S.S.
28	9	500209	3" FLANGE GASKET EPDM
29	11	520090	HOSE CLAMP NO 16 STAINLESS
30	1	311510	1.00 'L' HOSE, CHEM IND TANK
31	1	601510	HOSE, 1 X 26 1BR BLK EPDM
32	1	601511	HOSE, 1 X 38 1BR BLK EPDM
33	1	601512	HOSE, 1 X 8 2F-1W EPDM
34	1	601513	HOSE, 1 X 13 2F-1W EPDM
35	4	900064	5/16UNC X 3/4 HEX BOLT
36	4	920501	5/16 LOCK WASHER
37	4	920001	5/16 SAE FLAT WASHER
38	6	914002	5/16UNC HEX STOVER NUT
39	4	900066	5/16UNC X 1 1/4 HEX BOLT
40	1	520145	356 T-BOLT HOSE CLAMP SS
41	1	621052	LADDER,SIDE FILL CYL ASSYSTS12
42	1	601459	HOSE, 1 X 245 1BR BLK EDPM
43	1	690717	CHEM IND CYL MT WLD
44	6	914008	1/2UNC HEX STOVER NUT
45	4	900265	1/2UNC X 1 1/2 HEX BOLT
46	2	900267	1/2UNC X 2" HEX BOLT
47	1	473978	ROLL PIN, 1/2 X 3 1/2 LG
48	1	690729	3.50 OD X 2.68 ID X 11 GA WASH
49	1	690773	CHEM IND TANK MT WLD 2001
50	2	900067	5/16UNC X 1 1/2 HEX BOLT
51	1	690767	HYD MTR,BANJO PMP 3"POLY690760
52	1	701155	8" LID FOR 5 GAL TANK 701085

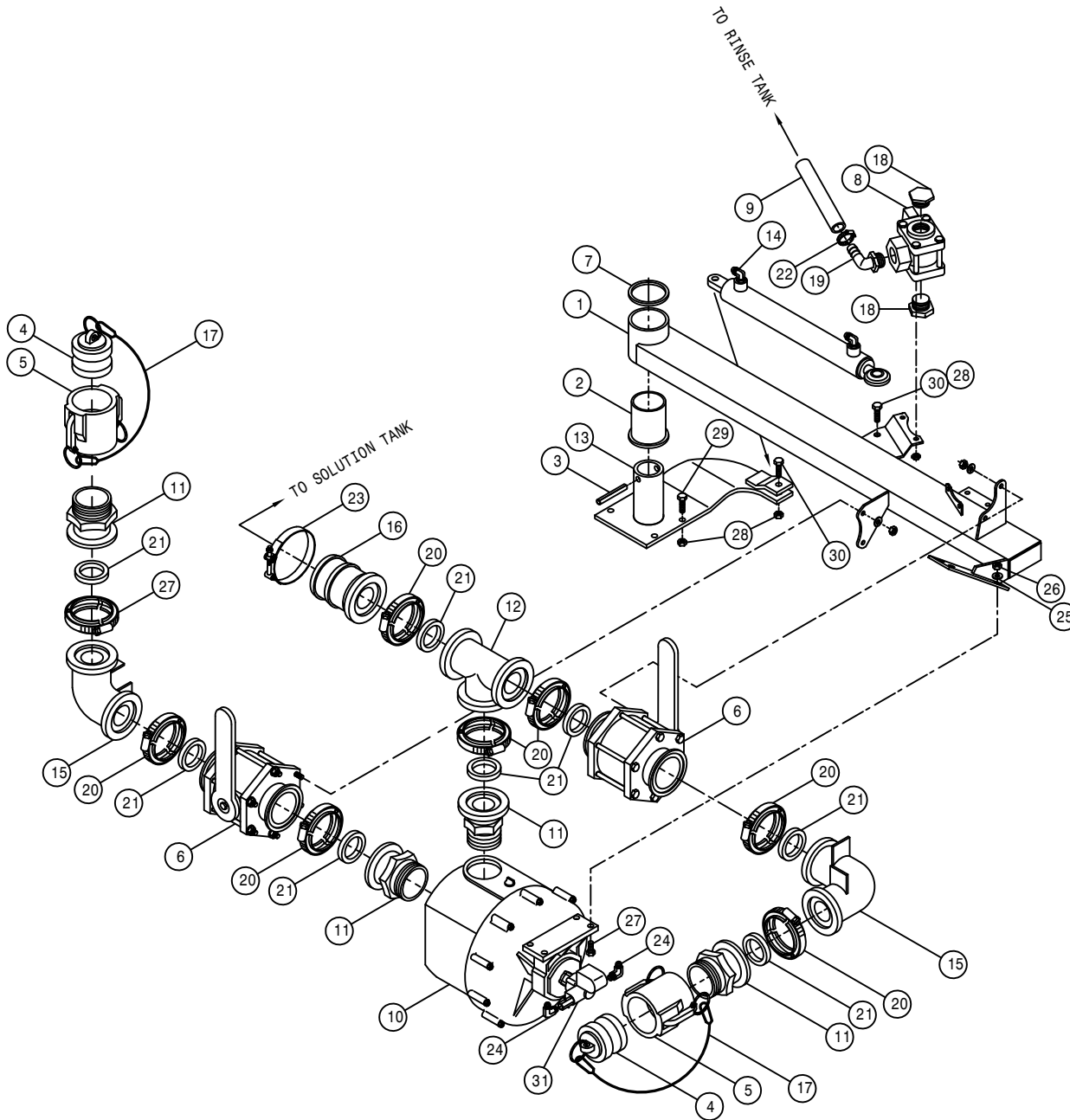

SIDE FILL ASSEMBLY

DET. QTY PART NO. DESCRIPTION

1	1	690703	SIDE FILL ARM WLD	2000
2	1	121101	TRANSOM PIVOT BRG, TOP	ORKOT
3	1	473978	ROLL PIN, 1/2 X 3 1/2 LG	
4	2	696232	PLUG FOR 3.00 FEMALE COUPLER	
5	2	696228	3.00FNPT-FEMALE COUPLER	POLY
6	2	696149	BALL VLV, 3" FLANGE	
7	1	690729	3.50 OD X 2.68 ID X 11 GA WASH	
8	1	696002	BALL VLV, 1.25NP 3WAY-SIDE	POLY
9	1	601459	HOSE, 1 X 245 1BR BLK	EDPM
10	1	690760	BANJO PUMP, 3" SIDE FILL	STS12
11	4	500164	3" FLANGE-3" MNPT ADPTR	POLY
12	1	500217	3" FLANGE TEE	POLY
13	1	690717	CHEM IND CYL MT WLD	
14	1	621052	LADDER, SIDE FILL CYL	ASSYSTS12
15	2	500213	3" FLANGE-90-3" FLANGE	LBO POLY
16	1	500210	3" FLANGE-3" HOSE BARB	POLY
17	2	470322	LANYARD, 8" NYLON LOOP/LOOP	
18	2	500064	1 1/4"NPT PIPE PLUG, POLY	
19	1	500102	1 1/4NPT-90-1" HOSE BARB	POLY
20	8	500208	3" FLANGE CLAMP, S.S.	
21	8	500209	3" FLANGE GASKET	EPDM
22	1	520090	HOSE CLAMP NO 16	STAINLESS
23	1	520145	356 T-BOLT HOSE CLAMP	SS
24	2	618183	3/4MJIC-90-7/8MOR	LBO
25	4	920001	5/16 SAE FLAT WASHER	
26	4	914002	5/16UNC HEX STOVER NUT	
27	4	900066	5/16UNC X 1 1/4 HEX BOLT	
28	6	914008	1/2UNC HEX STOVER NUT	
29	4	900265	1/2UNC X 1 1/2 HEX BOLT	
30	2	900267	1/2UNC X 2" HEX BOLT	
31	1	690767	HYD MTR, BANJO PMP 3"	POLY690760

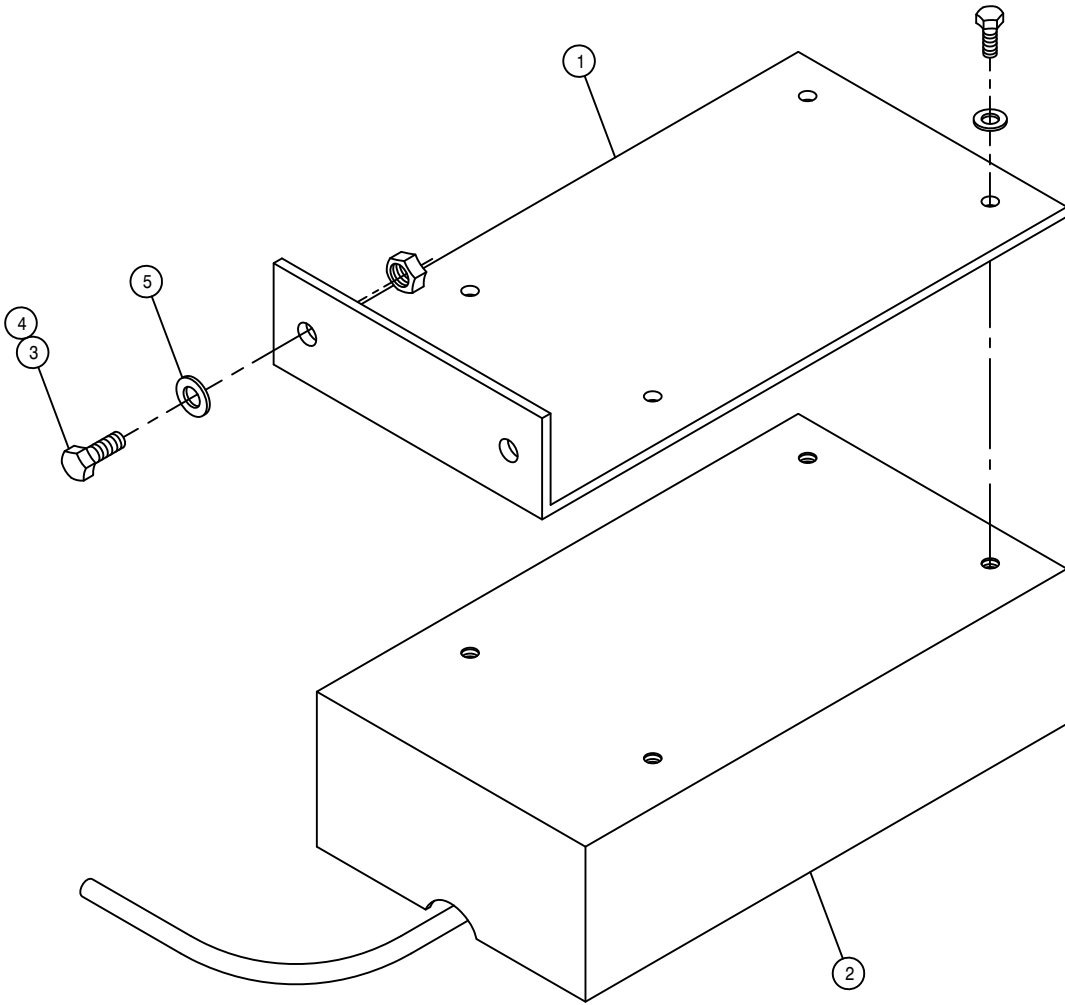

RADAR OPTION

DET. QTY PART NO. DESCRIPTION

1	1	342857	RADAR MTG BRKT
2	1	690599	RAVEN RADAR UNIT W/CABLE
3	2	900129	3/8UNC X 1" HEX BOLT
4	2	914004	3/8UNC HEX STOVER NUT
5	2	920002	3/8 SAE FLAT WASHER

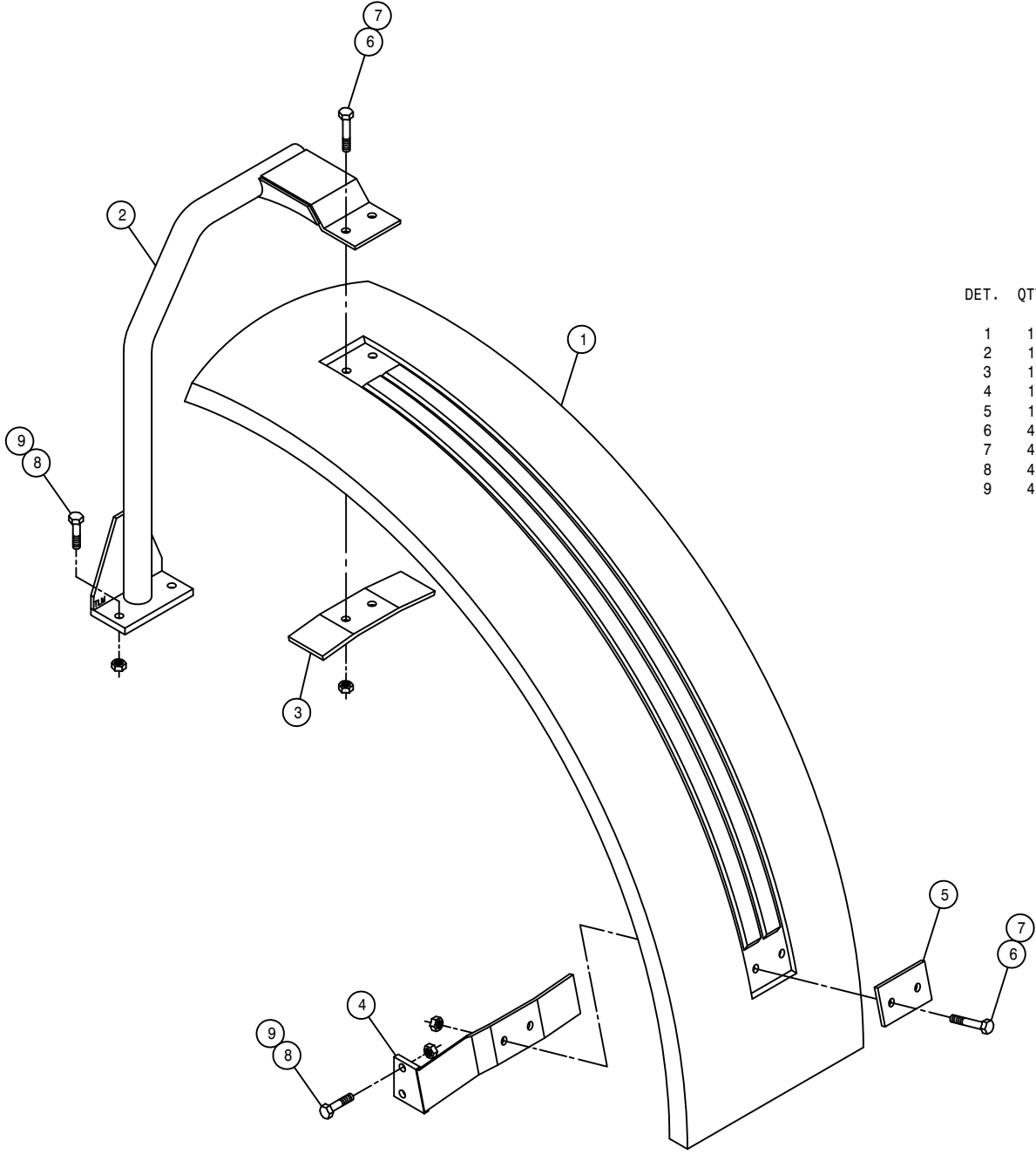

RIGHT FENDER ASSEMBLY

DET.	QTY	PART NO.	DESCRIPTION	
	1	359151	FENDER, STS12	2000
	1	359152	RH FENDER MT WLD	STS12
	1	359160	FENDER MT KEEPER	STS12
	1	359162	RH FENDER SUPP BRKT WLD	STS12
	1	359167	FENDER SUPPORT KEEPER	STS12
	4	473845	12MM-1.75 X 65MM HEX BOLT	
	4	473846	12MM-1.75 HEX STOVER NUT	
	4	900266	1/2UNC X 1 3/4 HEX BOLT	
	4	914008	1/2UNC HEX STOVER NUT	

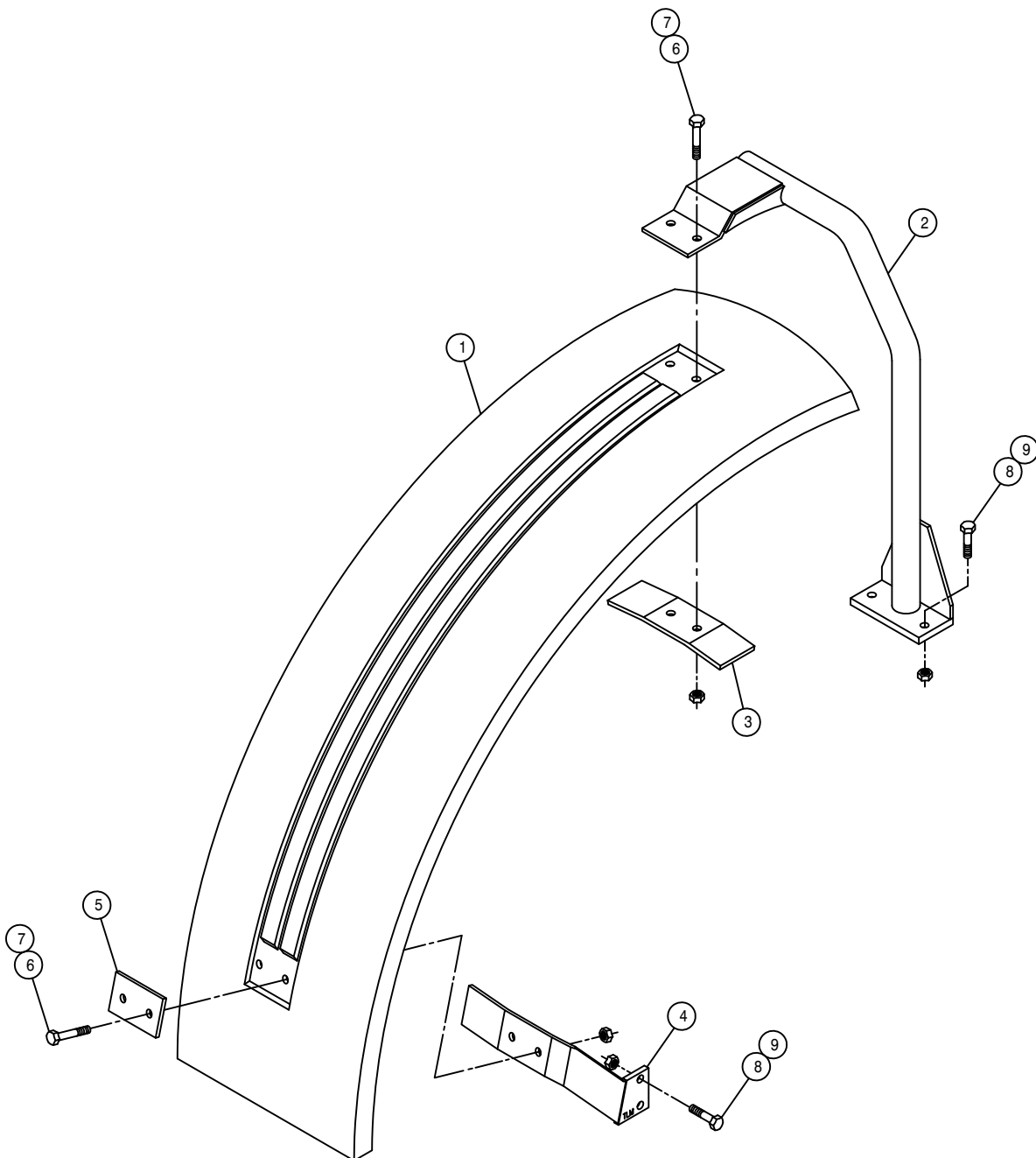

LEFT FENDER ASSEMBLY

DET.	QTY	PART NO.	DESCRIPTION	
1	1	359151	FENDER, STS12	2000
2	1	359153	LH FENDER MT WLD	STS12
3	1	359160	FENDER MT KEEPER	STS12
4	1	359163	LH FENDER SUPP BRKT WLD	STS12
5	1	359167	FENDER SUPPORT KEEPER	STS12
6	4	473845	12MM-1.75 X 65MM HEX BOLT	
7	4	473846	12MM-1.75 HEX STOVER NUT	
8	4	900266	1/2UNC X 1 3/4 HEX BOLT	
9	4	914008	1/2UNC HEX STOVER NUT	

NOTICE

The following page contains decals for the model STS 12.

These decals can be obtained from Hagie Mfg. Co. and should be used whenever your machine is repainted or when the decals become worn, weathered, or faded.

Special attention should be paid to decals involving personal safety. They have been attached for your protection.

KEEP THEM IN PLACE.

**Contact: Hagie Manufacturing Co.
Box 273
Clarion, Iowa 50525**

STS12 DECALS

<u>QTY.</u>	<u>PART NO.</u>	<u>DESCRIPTION</u>	<u>LOCATION</u>
1	650100	TREAD ADJ SWITCH PANEL DECAL	ON THE SWITCH PANEL
1	650102	HYDROSTATIC CONTROL PANEL DECAL	ON HYDRO LEVER MOUNT
4	650103	TREAD ADJUST INDICATOR DECAL	1-ON EACH LEG SLIDE TUBE
1	650104	ENGINE COMPARTMENT DECAL SET	ON ENGINE SHEET METAL
1	650105	SOLUTION TANK DECAL SET	ON SOLUTION TANK
1	650106	AGITATION VALVE DECAL	ON AGITATION ELECT VALVE
1	650107	CAUTION BOOSTER DECAL	NEAR BOOSTER POSTS
1	650108	MAIN SPRAY POWER DECAL	ON ATI CONTROL BOX
1	650109	LOW HYDRAULIC OIL DECAL	ON ATI CONTROL BOX
1	650110	PRESSURE WASHER DECAL	ON PRESSURE WASHER SWITCH BOX
1	650111	CHEMICAL INDUCTOR CONTROL DECAL	ON CHEM INDUCTOR CONTROL BOX
1	650112	HAGIE UPFRONT STRG WHEEL DECAL	ON STEERING WHEEL
1	650113	EMERGENCY EXIT DECAL	ON RH SIDE WINDOW HANDLE
1	650114	FILL WITH FRESH WATER DECAL	ON FRESH WATER TANK
1	650115	HAND WASH ONLY DECAL	NEAR HAND WASH VALVE
1	650116	INDUCTOR FILL INSTRUCTION DECAL	ON SIDE OF FILL ARM
1	650117	LATCH RELEASE DECAL	1-REAR RAD GRILLE DOOR
1	650118	DO NOT USE EITHER DECAL	NEAR AIR INTAKE ON SHEET METAL
1	650120	LATCH RELEASE W/ARROW DECAL	1-ENGINE SIDE DOOR
1	650337	ELECTROCUTION HAZARD DECAL	ON RH SIDE WINDOW
2	650339	WARNING, HYD OIL INJ DECAL	1-ON SIDE OF OIL TANK 1-NEAR ELECTIC VALVE ON TRANSOM
1	650340	CAUTION, PARKING BRAKE DECAL	ON RH SIDE WINDOW
1	650347	NOTICE-R134 DECAL	RH SIDE OF ENGINE ON FRAME
1	650848	CAUTION, SLIP OR FALL DECAL	ON LADDER PIVOT TUBE
1	650849	CAUTION, ENGINE FUEL DECAL	NEAR FUEL TANK NECK
1	650850	DANGEROUS CHEM DECAL	SOLUTION TANK FILLER NECK
1	650851	SHIELDS DECAL	ON LOWER LH REAR MAINFRAME TUBE
1	650852	READ MANUAL DECAL	ON LEFT SIDE WINDOW
1	650954	DIESEL DECAL	NEAR FUEL TANK NECK
1	650981	COOLING SYSTEM DECAL	NEAR RADIATOR CAP
1	650982	ELECTRICAL DECAL	ON RH CAB DOOR
4	650985	WHEEL BOLT TORQUE DECAL	ON EACH WHEEL RIM
1	650367	AIR FILTER INSTRUCTION DECAL	ON ENGINE AIR FILTER END CAP

LEFT FRONT WHEEL MOTOR

RIGHT FRONT WHEEL MOTOR

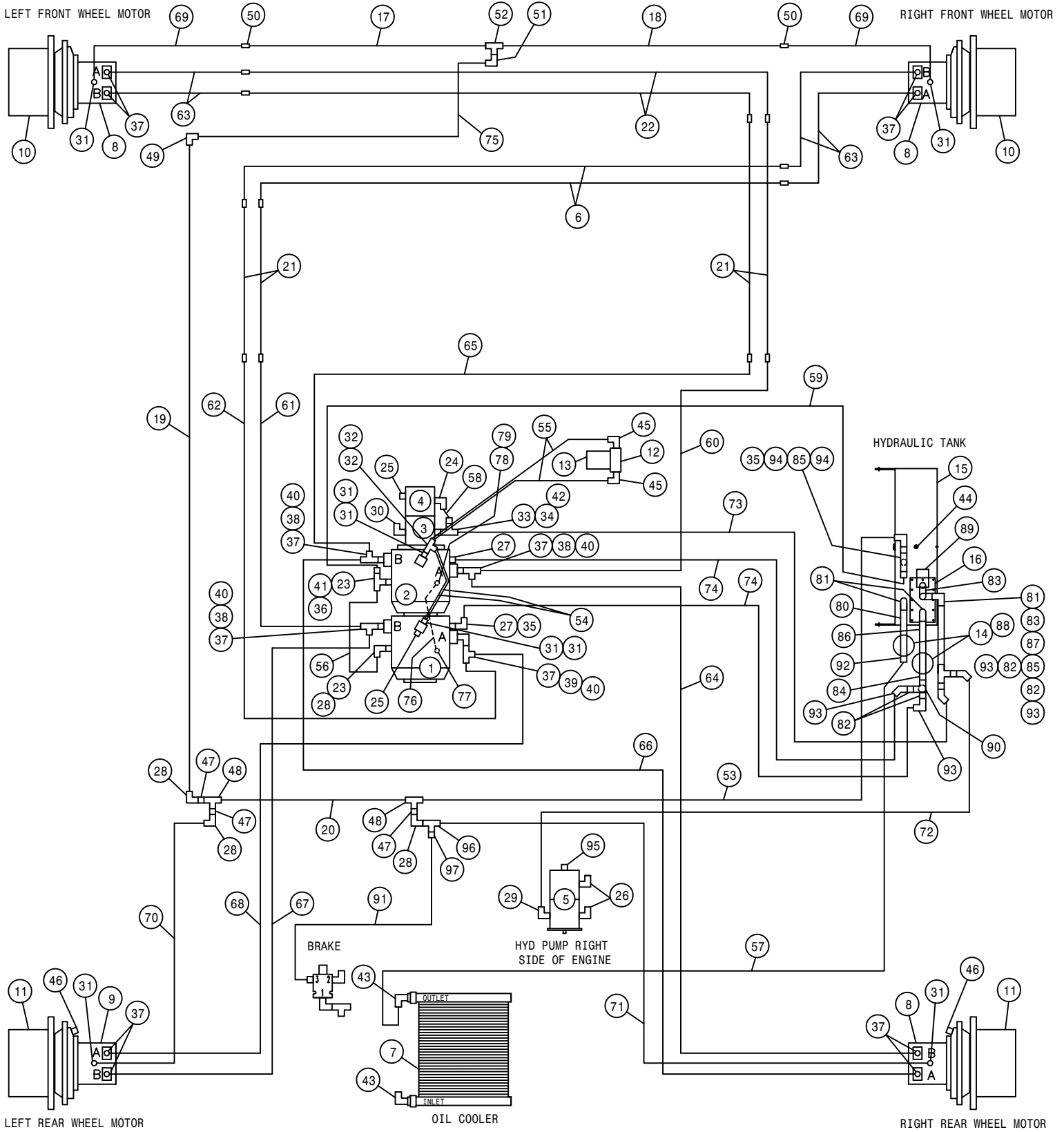

STS12 HYDRAULIC SCHEMATIC 2002
REFERENCE DRAWING NO. 498678S1

DET.	QTY	PART NO.	DESCRIPTION	DET.	QTY	PART NO.	DESCRIPTION
1	1	606966	SUND 75CC PUMP,C/C-MT	50	2	618456	7/8MJIC UNION
2	1	606969	SUND 75CC PUMP,C/B-MT	51	1	618301	7/8MJIC-90-7/8FJIC SWIV LBO
3	1	606984	SUND GEAR PUMP,2.02CI GRP3	52	1	618581	7/8MJIC UNION TEE
4	1	606987	SUND GEAR PUMP,.128CI GRP3	53	1	616127	16-421HT-16FJX-16FJX90-73 H/A
5	1	606990	TANDEM PUMP, .66CI/.51CI	54	2	616099	08-451TC-08FJX-08FJX-16 H/A
6	2	615784	RH FRT WHL MAIN HYD TUBE ASSY	55	2	616100	08-451TC-08FJX-08FJX-19 H/A
7	1	618800	OIL COOLER STS12 2000	56	1	616107	08-451TC-12FJX-12FJX-17 H/A
8	3	606978	SUND HYD MOTOR	57	1	616116	16-421HT-16FJX-20FJX-154 H/A
9	1	606981	SUND HYD MOTOR W/SENSOR	58	1	616117	06-451TC-06FJX-06FJX-17 H/A
10	2	610711	TORQ HUB, 22:1 CW12	59	1	616126	16-421HT-16FJX-16FJX-73 H/A
11	2	610714	TORQ HUB, 27:1 CW12	60	1	616061	16C15-16FFOX-16FFOX-30 H/A
12	1	605608	HYD FILTER HEAD, DONALDSON	61	1	616062	16C15-16FFOX-16FFOX-58 H/A
13	1	605609	HYD FILTER ELEMENT, DONALDSON	62	1	616063	16C15-16FFOX-16FFOX90-81 H/A
14	2	605611	FILTER HEAD, 1 1/2FNPTF ZINGA	63	4	616064	16C15-16FFOX-16FLG-132 H/A
15	1	760231	HYD TANK WLD STS12	64	1	616065	16C15-16FFOX-16FLG-165 H/A
16	1	760239	RECEIVER PLATE WLD STS12	65	1	616066	16C15-16FFOX90-16FFOX90-38 H/A
17	1	615775	LH FRT CASEDRAIN HYD TUBE ASSY	66	1	616067	16C15-16FFOX90-16FLG-193 H/A
18	1	615776	RH FRT CASEDRAIN HYD TUBE ASSY	67	1	616068	16C15-16FFOX90-16FLG-203 H/A
19	1	615778	FRT CASE DRAIN HYD TUBE ASSY	68	1	616069	16C15-16FFOX90-16FLG-223 H/A
20	1	615779	CASE DRAIN HYD TUBE ASSY	69	2	616103	08-451TC-08FJX-10FJX-136 H/A
21	4	615785	FRT WHL MAIN HYD TUBE ASSY	70	1	616104	08-451TC-08FJX-12FJX-160 H/A
22	2	615783	LH FRT WHL MAIN HYD TUBE ASSY	71	1	616106	08-451TC-08FJX-12FJX-175 H/A
23	2	611127	1 1/16MJIC-1 1/16MOR ADPTR	72	1	616110	16-451TC-12FJX-16FJX-84 H/A
24	1	618115	9/16MJIC-90-3/4MOR LBO	73	1	616111	16-451TC-16FJX-16FJX-32 H/A
25	2	618126	9/16MJIC-9/16MOR ADPTR	74	2	616112	16-451TC-16FJX-16FJX-42 H/A
26	2	618183	3/4MJIC-90-7/8MOR LBO	75	1	616113	10-421HT-10FJX-12FJX-55 H/A
27	2	618186	1 5/16MJIC-1 5/16MOR ADPTR	76	1	616038	04C2AT-06FJX-06FJX90-15 H/A
28	4	618191	1 1/16MJ-90-1 1/16FJ SWIV LBO	77	1	614754	.050 ELBOW ASSY,9/16MOR 90D
29	1	618248	1 1/16MJIC-90-1 1/16MOR LBO	78	1	618444	9/16MOR RUN TEE-9/16MJIC
30	1	618302	1 1/16MJIC-90-1 5/16MOR LBO	79	1	618531	9/16FJIC CAP NUT
31	8	618327	3/4MJIC-7/8MOR ADPTR	80	1	507009	BLK PIPE NIPPLE 1.50NPT-6.00
32	2	618451	3/4FJIC SW RUN TEE-3/4MJIC	81	3	507014	BLK PIPE EL 90DEG 1.50NPT
33	1	618455	1 5/16MJIC-1 5/8MOR ADPTR	82	4	507015	RED BUSH 1.50NPT - 1.25FNPT
34	1	618619	1 5/16FJ SW RUN TEE-1 5/16MJ	83	2	507018	BLK PIPE ST EL 90DEG 1.50NPT
35	2	618640	1 5/16MJ-90-1 5/16FJ SWIV LBO	84	1	507019	CLOSE NIPPLE 1.50NPT
36	1	618641	1 1/16FJIC-1 5/16MJIC ADPTR	85	2	507250	BLK PIPE TEE 1.50NPT
37	12	618652	1" SPLIT FLANGE KIT	86	1	507610	BLK PIPE NIPPLE 1.50NPT-8.00
38	3	618653	1" FLANGE-1 7/16MFOR ADPTR	87	1	507617	BLK PIPE NIPPLE 1.50NPT-16.00
39	1	618654	1" FLANGE-90-1 7/16MFOR LBO	88	2	605612	FILTER, 10 MICRON ZINGA
40	4	618655	1 7/16FFOX RUN TEE-1 7/16MFOR	89	1	605613	TANK FILTER,100 MESH,1 1/2FNPT
41	1	618660	1 1/16FJX BRANCH TEE-1 1/16MJ	90	1	507252	SIDE OUTLET EL 90DEG 1.50NPT
42	1	618661	1 5/16FJIC-9/16MJIC ADPTR	91	1	616078	04-451TC-06FJX-06FJX-26 H/A
43	2	618463	1 5/16MJIC-90-1 5/16MOR XL LBO	92	1	618656	1 5/8MJIC-1 1/2MNPT ADPTR
44	1	470308	1/2MNPT DRAIN PLUG,AL HD,MAG	93	4	618667	1 5/16MJIC-45-1 1/4MNPT LBO
45	2	618474	3/4MJIC-90-1 1/16MOR LBO	94	2	618672	1 5/16MJIC-1 1/2MNPT ADPTR
46	2	618666	7/16MJIC-M12X1.5MOR ADPTR	95	1	618315	3/4MJIC-45-3/4MOR LBO
47	3	618541	1 5/16FJIC-1 1/16MJIC ADPTR	96	1	618487	1 1/16FJ SW RUN TEE-1 1/16MJ
48	2	618658	1 5/16MJIC UNION TEE	97	1	618483	1 1/16FJIC-9/16MJIC ADPTR
49	1	618448	1 1/16MJIC-90-1 1/16MJIC LBO				

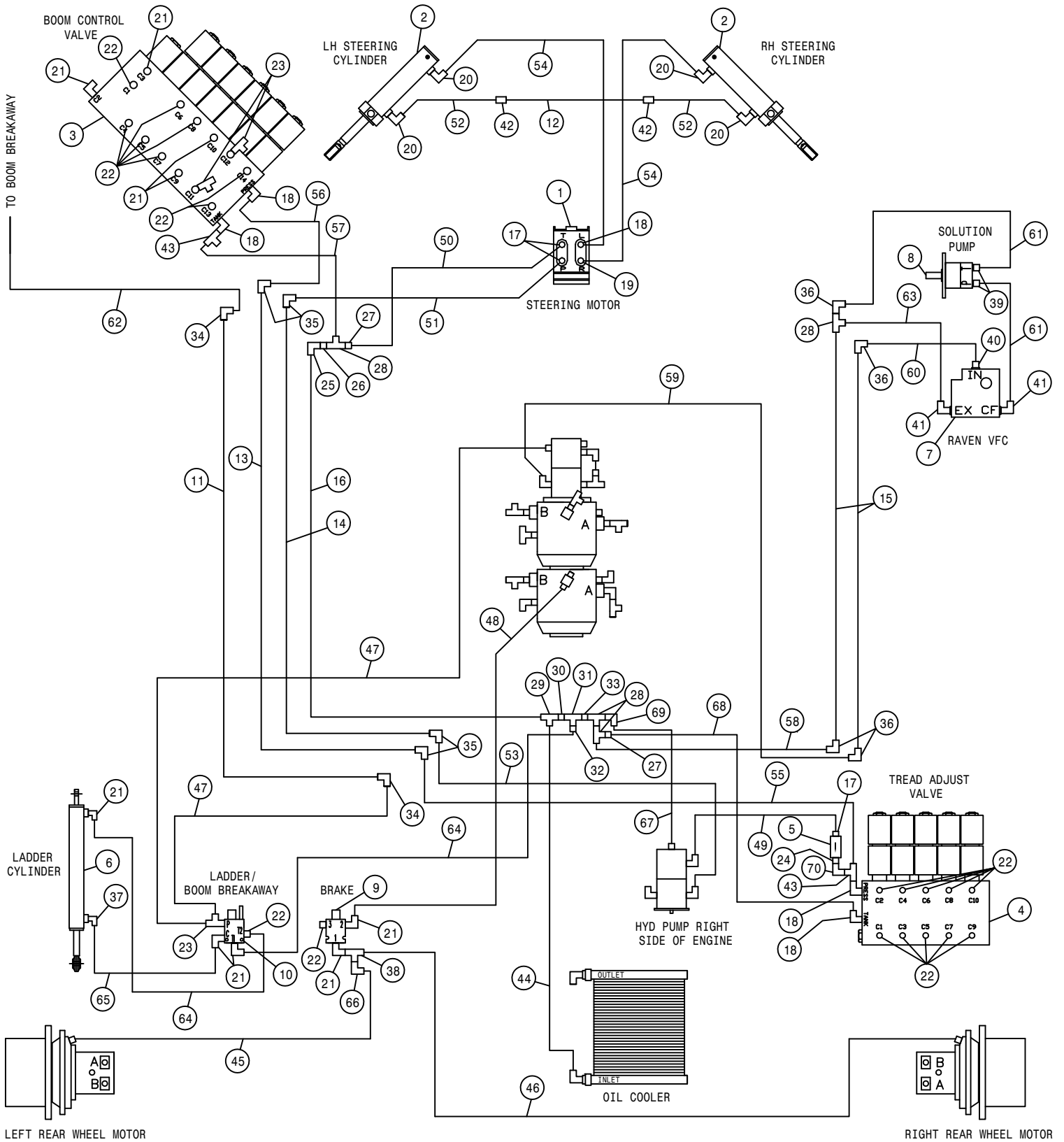

STS12 HYDRAULIC SCHEMATIC 2002
REFERENCE DRAWING NO. 498678S2

DET.	QTY	PART NO.	DESCRIPTION	DET.	QTY	PART NO.	DESCRIPTION
1	1	749321	STEERING CONTROL MTR 14.1CI	36	4	618448	1 1/16MJIC-90-1 1/16MJIC LBO
2	2	620910	STEERING CYL,2.50 X 8.81	37	1	614750	.042 ELBOW ASSY,9/16MOR 90D
3	1	606051	DELTA HYD MANIFOLD ASSY, 2703	38	1	618486	9/16FJIC SW RUN TEE-9/16MJIC
4	1	606050	DELTA HYD MANIFOLD ASSY, 2704	39	2	618273	1 1/16MJIC-1/2MNPT ADPTR
5	1	605610	HYD FILTER, INLINE 90M 3/4FOR	40	1	611127	1 1/16MJIC-1 1/16MOR ADPTR
6	1	620920	LADDER CYL, 1.50 X 12.25	41	2	618248	1 1/16MJIC-90-1 1/16MOR LBO
7	1	690666	VALVE HYD CTRL,30GPM RAVEN	42	2	618314	3/4MJIC UNION
8	1	690670	HYPRO PUMP, 9305C-HM3CB	43	2	618451	3/4FJIC SW RUN TEE-3/4MJIC
9	1	606013	BRAKE VLV W/TOWER ASSY	44	1	616115	16-421HT-16FJX-20FJX-100 H/A
10	1	606011	LADDER/BRKWAY VLV W/TOWER ASSY	45	1	616072	04-451TC-04FJX45-06FJX-195 H/A
11	1	615771	BRKAWAY/TRD MAIN HYD TUBE ASSY	46	1	616073	04-451TC-04FJX45-06FJX-202 H/A
12	1	615772	STRG CYL JUMPER HYD TUBE ASSY	47	2	616080	04-451TC-06FJX-06FJX-30 H/A
13	1	615773	STACK VALVE MAIN HYD TUBE ASSY	48	1	616081	04-451TC-06FJX-06FJX-31 H/A
14	1	615774	STEERING MAIN HYD TUBE ASSY	49	1	616093	08-451TC-08FJX-08FJX-86 H/A
15	2	615777	SOLUTION PUMP HYD TUBE ASSY	50	1	616094	06-451TC-08FJX-08FJX-31 H/A
16	1	615782	FRT MAIN RETURN HYD TUBE ASSY	51	1	616095	06-451TC-08FJX-08FJX-33 H/A
17	3	611125	3/4MJIC-3/4MOR ADPTR	52	2	616096	06-451TC-08FJX-08FJX-37 H/A
18	5	618241	3/4MJIC-90-3/4MOR LBO	53	1	616097	08-451TC-08FJX-08FJX-90 H/A
19	1	618443	3/4MJIC-90-3/4MOR EX LG LBO	54	2	616098	06-451TC-08FJX-08FJX-94 H/A
20	4	618249	3/4MJIC-90-9/16MOR LBO	55	1	616101	08-451TC-08FJX-08FJX-31 H/A
21	9	618119	9/16MJIC-90-9/16MOR LBO	56	1	616102	08-451TC-08FJX-08FJX-132 H/A
22	20	618126	9/16MJIC-9/16MOR ADPTR	57	1	616105	08-451TC-08FJX-12FJX-132 H/A
23	3	618444	9/16MOR RUN TEE-9/16MJIC	58	1	616108	10-451TC-12FJX-12FJX-28 H/A
24	1	618669	3/4FJIC SWIV-3/4MOR ADPTR	59	1	616109	10-451TC-12FJX-12FJX-32 H/A
25	1	618657	1 5/8MJIC-90-1 5/8MJIC LBO	60	1	616120	10-451TC-12FJX-12FJX-16 H/A
26	1	618665	1 5/8FJIC-1 1/16MJIC ADPTR	61	2	616121	10-451TC-12FJX90-12FJX-32 H/A
27	2	618484	1 1/16FJIC-3/4MJIC ADPTR	62	1	616123	04-451TC-06FJX-06FJX-142 H/A
28	4	618487	1 1/16FJ SW RUN TEE-1 1/16MJ	63	1	616125	10-451TC-12FJX-12FJX-22 H/A
29	1	618659	1 5/8MJIC UNION TEE	64	2	616083	04-451TC-06FJX-06FJX-36 H/A
30	1	618547	1 5/8FJIC-1 5/16MJIC ADPTR	65	1	616086	04-451TC-06FJX-06FJX-45 H/A
31	1	618619	1 5/16FJ SW RUN TEE-1 5/16MJ	66	1	618618	9/16MJIC-90-9/16FJIC SWIV LBO
32	1	618661	1 5/16FJIC-9/16MJIC ADPTR	67	1	616136	08-451TC-08FJX-12FJX-72 H/A
33	1	618541	1 5/16FJIC-1 1/16MJIC ADPTR	68	1	616139	08-451TC-08FJX-08FJX-36 H/A
34	2	618603	9/16MJIC-90-9/16MJIC LBO	69	1	618191	1 1/16MJ-90-1 1/16FJ SWIV LBO
35	4	618442	3/4MJIC-90-3/4MJIC LBO	70	1	618609	3/4MJIC-90-3/4FJIC SWIV LBO

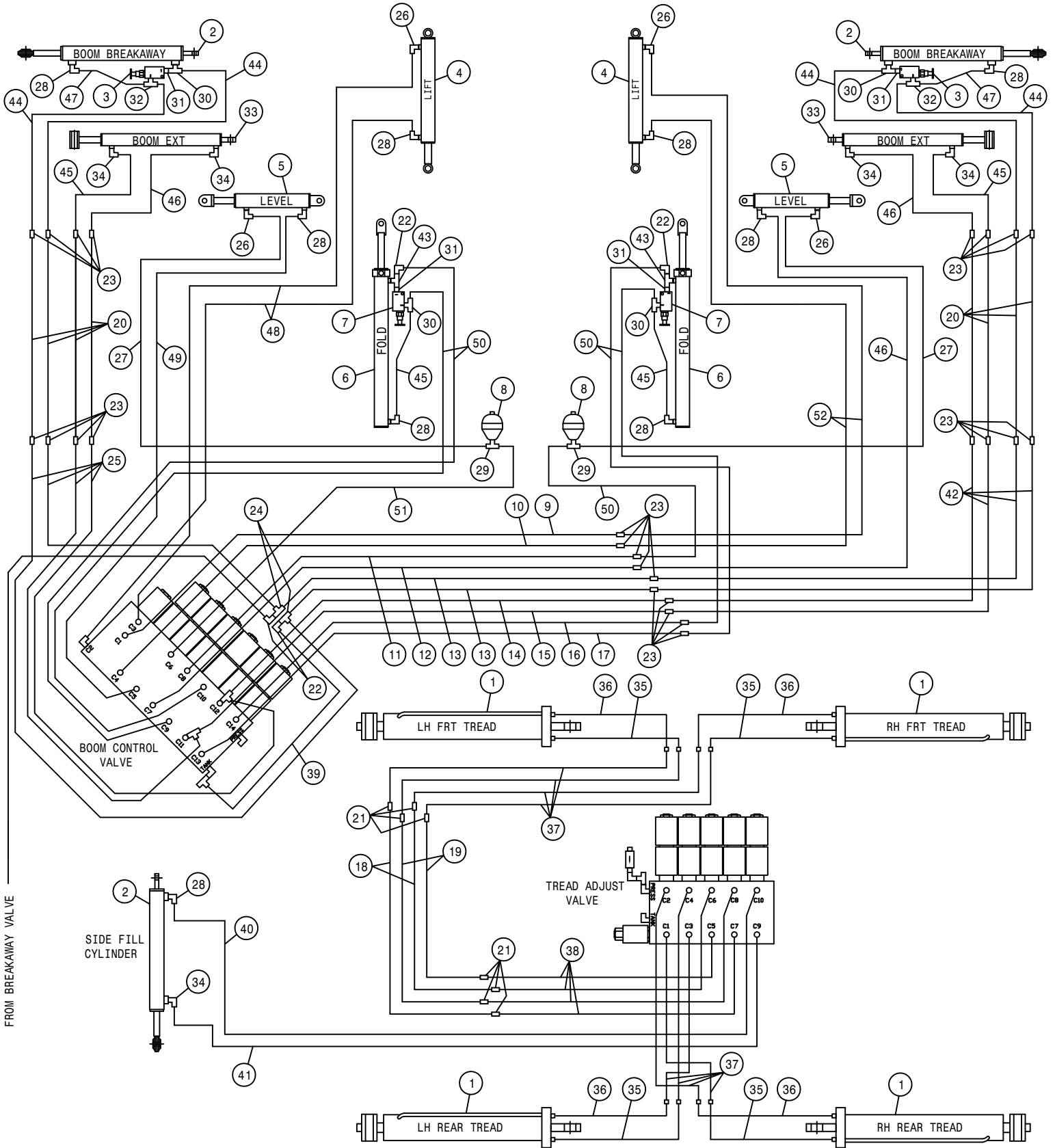

STS12 HYDRAULIC SCHEMATIC 2002
REFERENCE DRAWING NO. 498678S3

DET.	QTY	PART NO.	DESCRIPTION	DET.	QTY	PART NO.	DESCRIPTION
1	4	620915	TRD ADJ CYL, 3.00 X 16.00	27	2	616128	06-451TC-06FJX-06FJX-48 H/A
2	3	620920	LADDER CYL, 1.50 X 12.25	28	9	618119	9/16MJIC-90-9/16MOR LBO
3	2	607540	KICK-DOWN RELIEF VALVE, 800PSI	29	2	618673	3/4MOR BRANCH TEE-9/16MJIC
4	2	620925	LIFT CYL, 2.50 X 18.00	30	4	618629	9/16MOR BRANCH TEE-9/16MJIC
5	2	620950	LEVEL CYL, 3.00 X 11.00	31	4	618668	9/16FJIC SWIV-9/16MOR ADPTR
6	2	620940	FOLD CYL, 2.50 X 21.00	32	2	614752	RESTRICTOR BR TEE ASSY, .042DIA
7	2	607541	KICK-DOWN RELIEF VALVE, 4500PSI	33	2	620945	OUTR FOLD CYL, 2.25 X 21.00
8	2	470326	ACCUMULATOR, DIAPHRAGM	34	5	614750	.042 ELBOW ASSY, 9/16MOR 90D
9	1	615761	LIFT RAISE HYD TUBE ASSY	35	4	616070	04-451TC-04MJBH-06MOR-11.00H/A
10	1	615762	LIFT LOWER HYD TUBE ASSY	36	4	616071	04-451TC-04MJBH-06MOR-13.00H/A
11	1	615763	LEVEL RAISE HYD TUBE ASSY	37	8	616074	04-451TC-04FJX90-06FJX-26 H/A
12	1	615764	LEVEL LOWER HYD TUBE ASSY	38	4	616079	04-451TC-06FJX-06FJX-29 H/A
13	2	615765	BREAKAWAY HYD TUBE ASSY	39	1	616124	04-451TC-06FJX-08FJX-24 H/A
14	1	615766	BOOM EXTN RAISE HYD TUBE ASSY	40	1	616118	04-451TC-06FJX-06FJX-165 H/A
15	1	615767	BOOM EXTN LOWER HYD TUBE ASSY	41	1	616119	04-451TC-06FJX-06FJX-175 H/A
16	1	615768	RH FOLD RAISE HYD TUBE ASSY	42	4	616089	04-451TC-06FJX-06FJX-60 H/A
17	1	615769	RH FOLD LOWER HYD TUBE ASSY	43	2	614756	RESTRICTOR BR TEE ASSY, .025DIA
18	2	615770	FRT TRD ADJ MAIN HYD TUBE ASSY	44	4	616090	04-451TC-06FJX-06FJX-85 H/A
19	2	615771	BRKAWAY/TRD MAIN HYD TUBE ASSY	45	4	616077	04-451TC-06FJX-06FJX-18 H/A
20	8	615760	BOOM HYD TUBE ASSY	46	3	616083	04-451TC-06FJX-06FJX-36 H/A
21	8	618603	9/16MJIC-90-9/16MJIC LBO	47	2	616075	04-451TC-06FJX-06FJX-9 H/A
22	4	618618	9/16MJIC-90-9/16FJIC SWIV LBO	48	2	616084	04-451TC-06FJX-06FJX-46 H/A
23	26	619010	9/16MJIC UNION	49	1	616085	04-451TC-06FJX-06FJX-43 H/A
24	2	618019	9/16MJIC UNION TEE	50	5	616086	04-451TC-06FJX-06FJX-45 H/A
25	4	616133	04-451TC-06FJX-06FJX-72 H/A	51	1	616087	04-451TC-06FJX-06FJX-52 H/A
26	4	618689	9/16MOR-90-9/16MJ .042 CHK VLV	52	2	616088	04-451TC-06FJX-06FJX-56 H/A

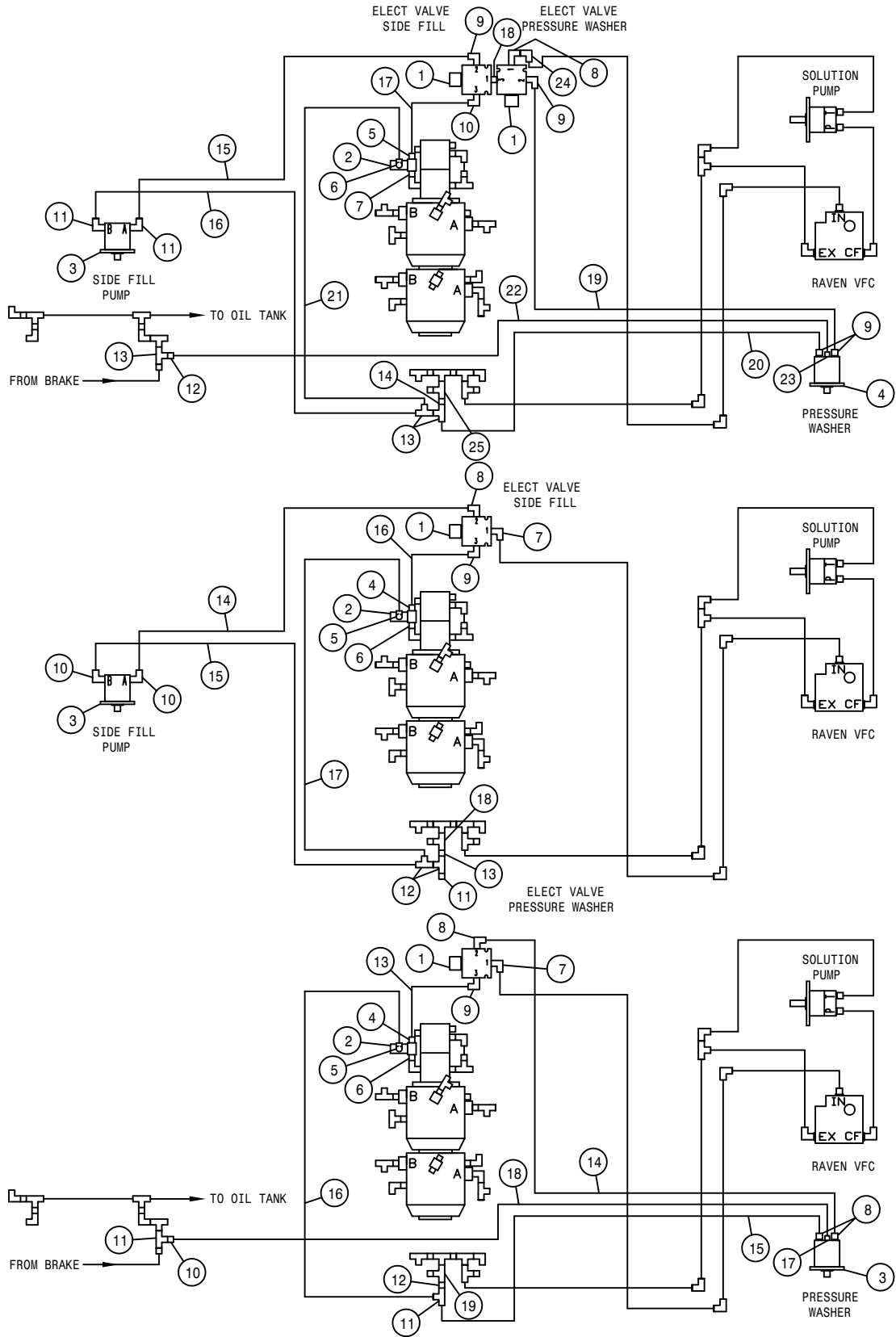

SIDE FILL AND PRESSURE WASHER OPTION
REFERENCE DRAWING NO. 498678S4

DET.	QTY	PART NO.	DESCRIPTION	DET.	QTY	PART NO.	DESCRIPTION
1	2	606015	SIDE-FILL/WASH VLV W/SHRD ASSY	13	3	618487	1 1/16FJ SW RUN TEE-1 1/16MJ
2	1	607550	IN-LINE RELIEF VALVE, 2600 PSI	14	1	618541	1 5/16FJIC-1 1/16MJIC ADPTR
3	1	690760	BANJO PUMP,3" SIDE FILL STS12	15	1	616129	08-451TC-08FJX-08FJX-204 H/A
4	1	690672	PRESSURE WASHER,PACE 320 HYD	16	1	616130	08-451TC-08FJX-12FJX-204 H/A
5	1	611127	1 1/16MJIC-1 1/16MOR ADPTR	17	1	616131	10-451TC-12FJX-12FJX-14 H/A
6	1	618279	1 1/16MJIC-90-7/8MOR LBO	18	1	618675	1 1/16MOR UNION
7	1	618578	1 1/16FJIC SWIV-1 1/16MOR	19	1	616135	08-451TC-08FJX-08FJX-50 H/A
8	1	618248	1 1/16MJIC-90-1 1/16MOR LBO	20	1	616134	08-451TC-08FJX-12FJX-60 H/A
9	4	618474	3/4MJIC-90-1 1/16MOR LBO	21	1	616132	08-451TC-12FJX-12FJX-18 H/A
10	1	618674	1 1/16MJIC-90-1 1/16MOR XL LBO	22	1	616089	04-451TC-06FJX-06FJX-60 H/A
11	2	618183	3/4MJIC-90-7/8MOR LBO	23	1	618119	9/16MJIC-90-9/16MOR LBO
12	1	618483	1 1/16FJIC-9/16MJIC ADPTR	24	1	618191	1 1/16MJ-90-1 1/16FJ SWIV LBO
				25	1	618619	1 5/16FJ SW RUN TEE-1 5/16MJ

SIDE FILL OPTION

DET.	QTY	PART NO.	DESCRIPTION	DET.	QTY	PART NO.	DESCRIPTION
1	1	606015	SIDE-FILL/WASH VLV W/SHRD ASSY	10	2	618183	3/4MJIC-90-7/8MOR LBO
2	1	607550	IN-LINE RELIEF VALVE, 2600 PSI	11	1	618483	1 1/16FJIC-9/16MJIC ADPTR
3	1	690760	BANJO PUMP,3" SIDE FILL STS12	12	2	618487	1 1/16FJ SW RUN TEE-1 1/16MJ
4	1	611127	1 1/16MJIC-1 1/16MOR ADPTR	13	1	618541	1 5/16FJIC-1 1/16MJIC ADPTR
5	1	618279	1 1/16MJIC-90-7/8MOR LBO	14	1	616129	08-451TC-08FJX-08FJX-204 H/A
6	1	618578	1 1/16FJIC SWIV-1 1/16MOR	15	1	616130	08-451TC-08FJX-12FJX-204 H/A
7	1	618248	1 1/16MJIC-90-1 1/16MOR LBO	16	1	616131	10-451TC-12FJX-12FJX-14 H/A
8	1	618474	3/4MJIC-90-1 1/16MOR LBO	17	1	616132	08-451TC-12FJX-12FJX-18 H/A
9	1	618674	1 1/16MJIC-90-1 1/16MOR XL LBO	18	1	618619	1 5/16FJ SW RUN TEE-1 5/16MJ

PRESSURE WASHER OPTION

DET.	QTY	PART NO.	DESCRIPTION	DET.	QTY	PART NO.	DESCRIPTION
1	1	606015	SIDE-FILL/WASH VLV W/SHRD ASSY	11	2	618487	1 1/16FJ SW RUN TEE-1 1/16MJ
2	1	607550	IN-LINE RELIEF VALVE, 2600 PSI	12	1	618541	1 5/16FJIC-1 1/16MJIC ADPTR
3	1	690672	PRESSURE WASHER,PACE 320 HYD	13	1	616131	10-451TC-12FJX-12FJX-14 H/A
4	1	611127	1 1/16MJIC-1 1/16MOR ADPTR	14	1	616135	08-451TC-08FJX-08FJX-50 H/A
5	1	618279	1 1/16MJIC-90-7/8MOR LBO	15	1	616134	08-451TC-08FJX-12FJX-60 H/A
6	1	618578	1 1/16FJIC SWIV-1 1/16MOR	16	1	616132	08-451TC-12FJX-12FJX-18 H/A
7	1	618248	1 1/16MJIC-90-1 1/16MOR LBO	17	1	618119	9/16MJIC-90-9/16MOR LBO
8	3	618474	3/4MJIC-90-1 1/16MOR LBO	18	1	616089	04-451TC-06FJX-06FJX-60 H/A
9	1	618674	1 1/16MJIC-90-1 1/16MOR XL LBO	19	1	618619	1 5/16FJ SW RUN TEE-1 5/16MJ
10	1	618483	1 1/16FJIC-9/16MJIC ADPTR				

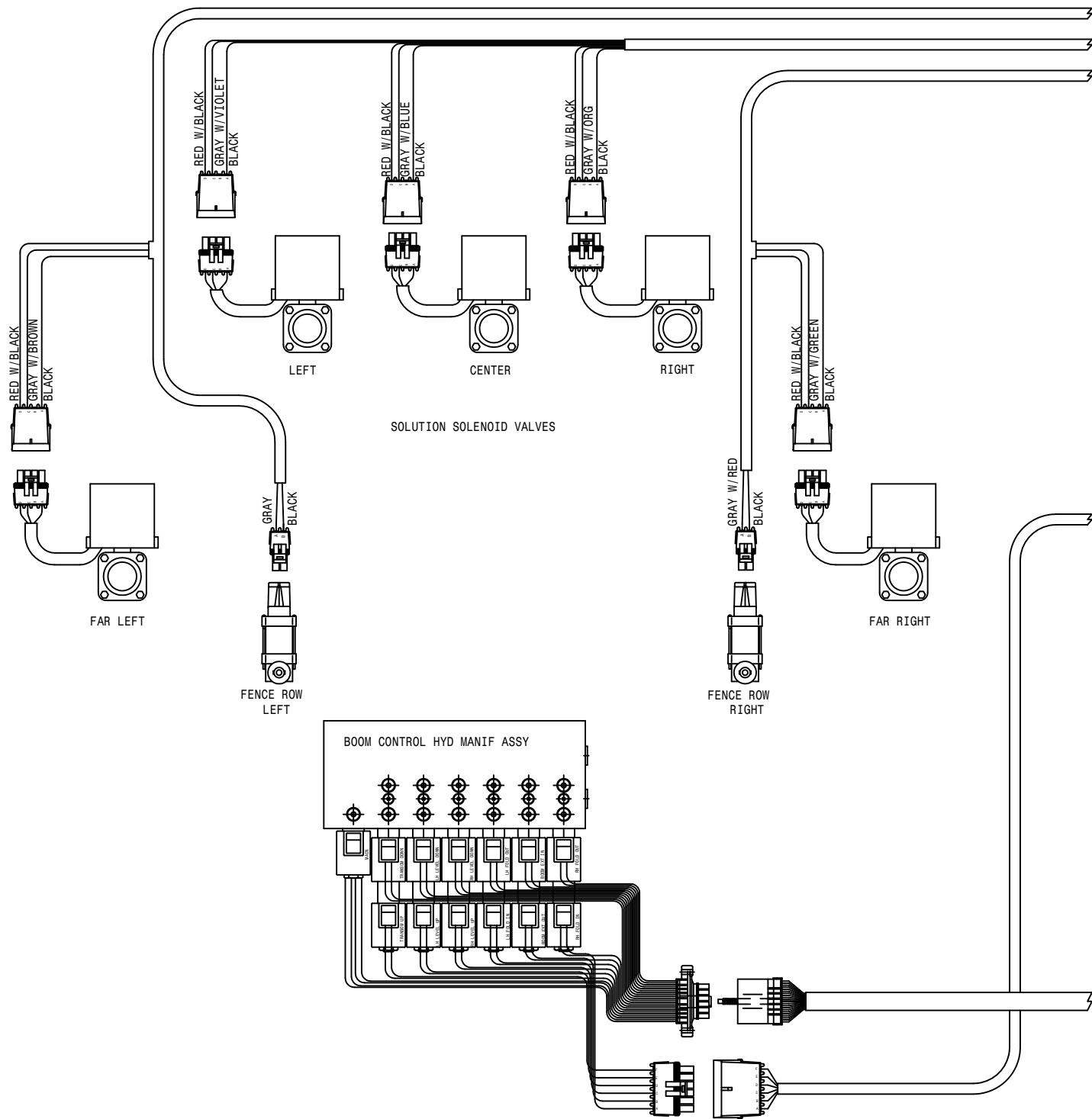

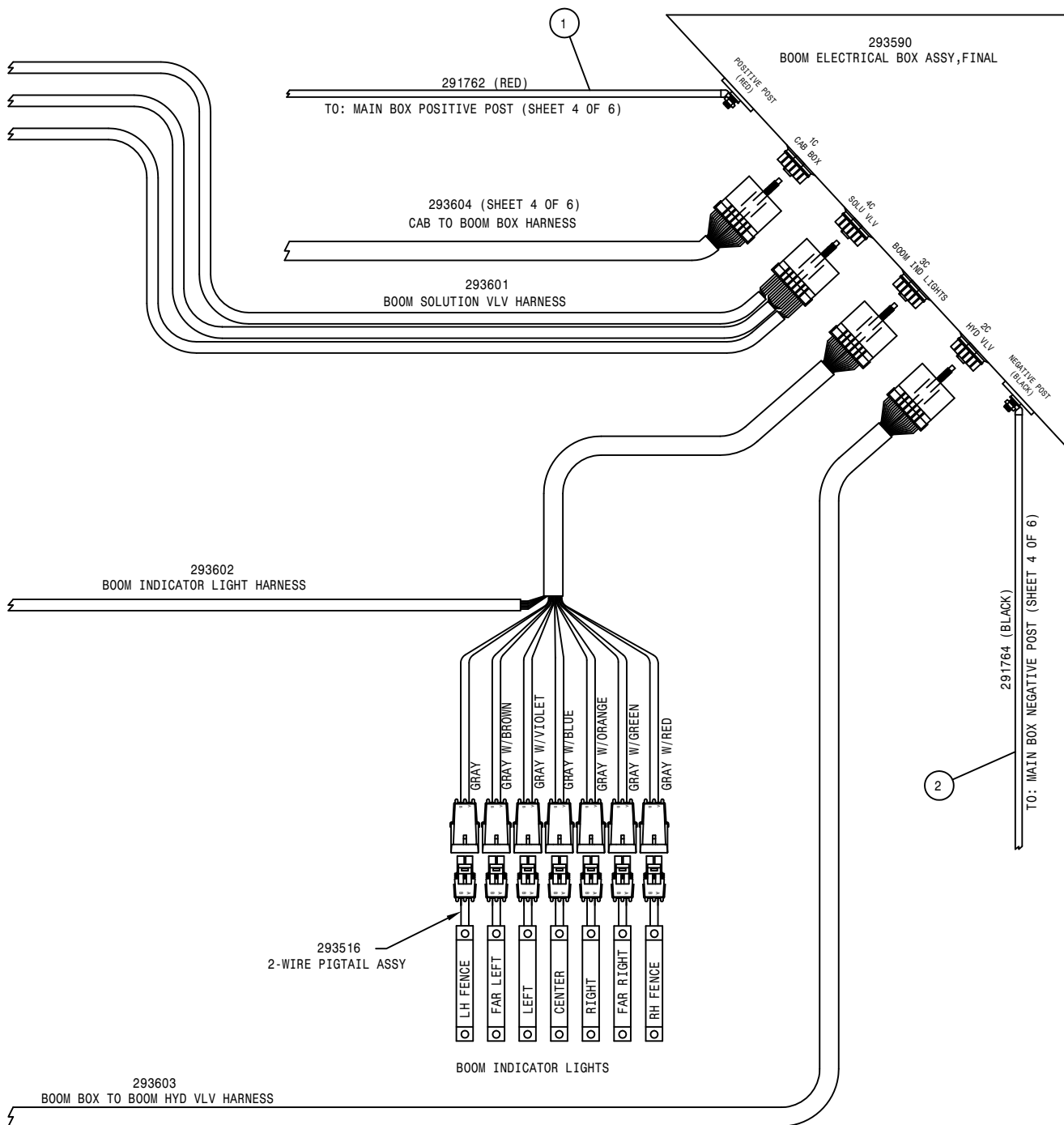

2	1	291764	BATT CABLE, BLK 144" 6GA3/8-3/8
1	1	291762	BATT CABLE, RED 107"6GA 1/4-3/8
06-14-01 CRA			
STS 12 WIRING DIAGRAM 02			
SHEET 1 OF 6			498635
REVISION DATE: 12-19-01			

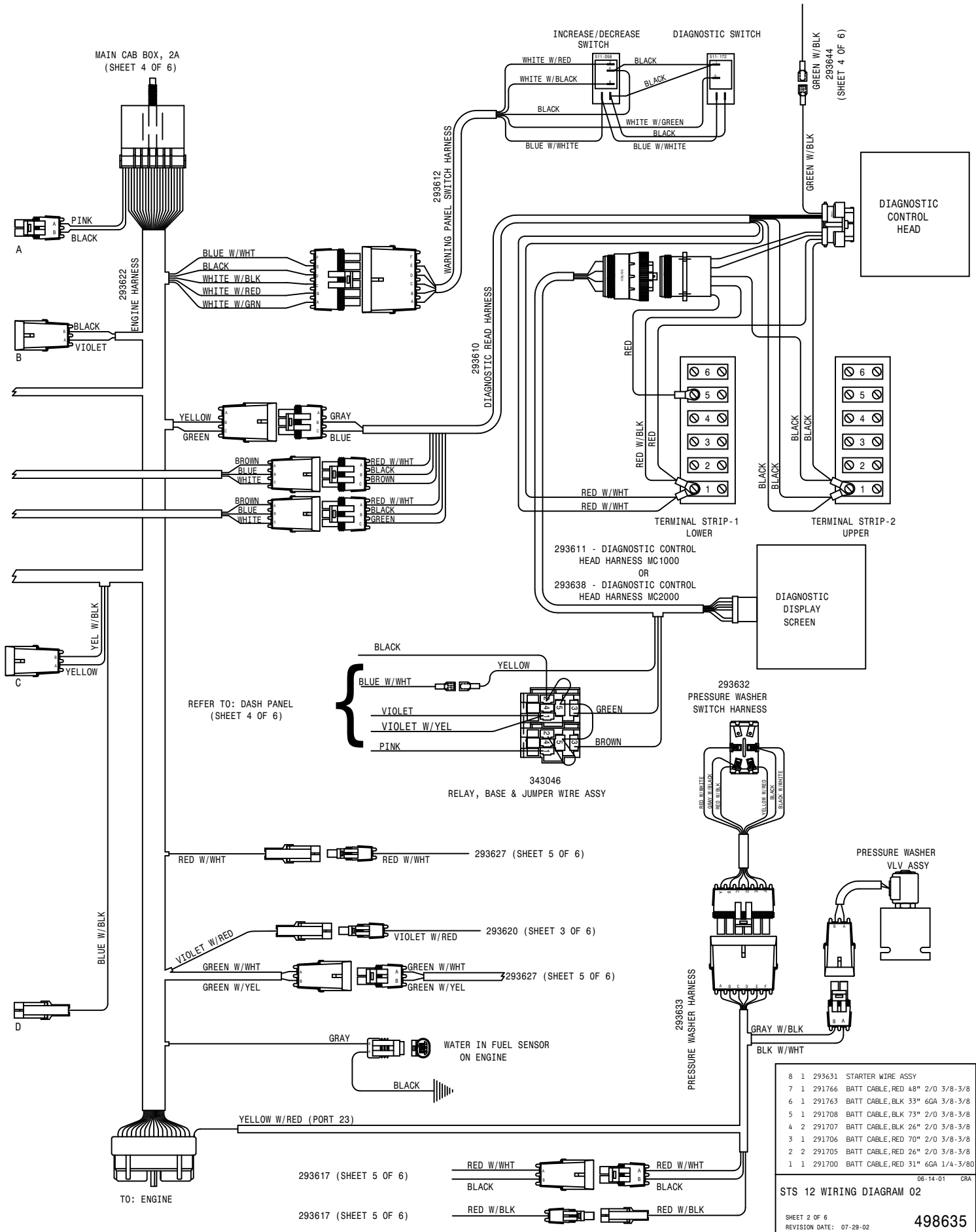

8	1	293631	STARTER WIRE ASSY
7	1	291766	BATT CABLE, RED 48" 2/0 3/8-3/8
6	1	291763	BATT CABLE, BLK 33" 6GA 3/8-3/8
5	1	291708	BATT CABLE, BLK 73" 2/0 3/8-3/8
4	2	291707	BATT CABLE, BLK 26" 2/0 3/8-3/8
3	1	291706	BATT CABLE, RED 70" 2/0 3/8-3/8
2	2	291705	BATT CABLE, RED 26" 2/0 3/8-3/8
1	1	291700	BATT CABLE, RED 31" 6GA 1/4-3/80

06-14-01 CRA

STS 12 WIRING DIAGRAM 02

SHEET 2 OF 6
REVISION DATE: 07-29-02

498635

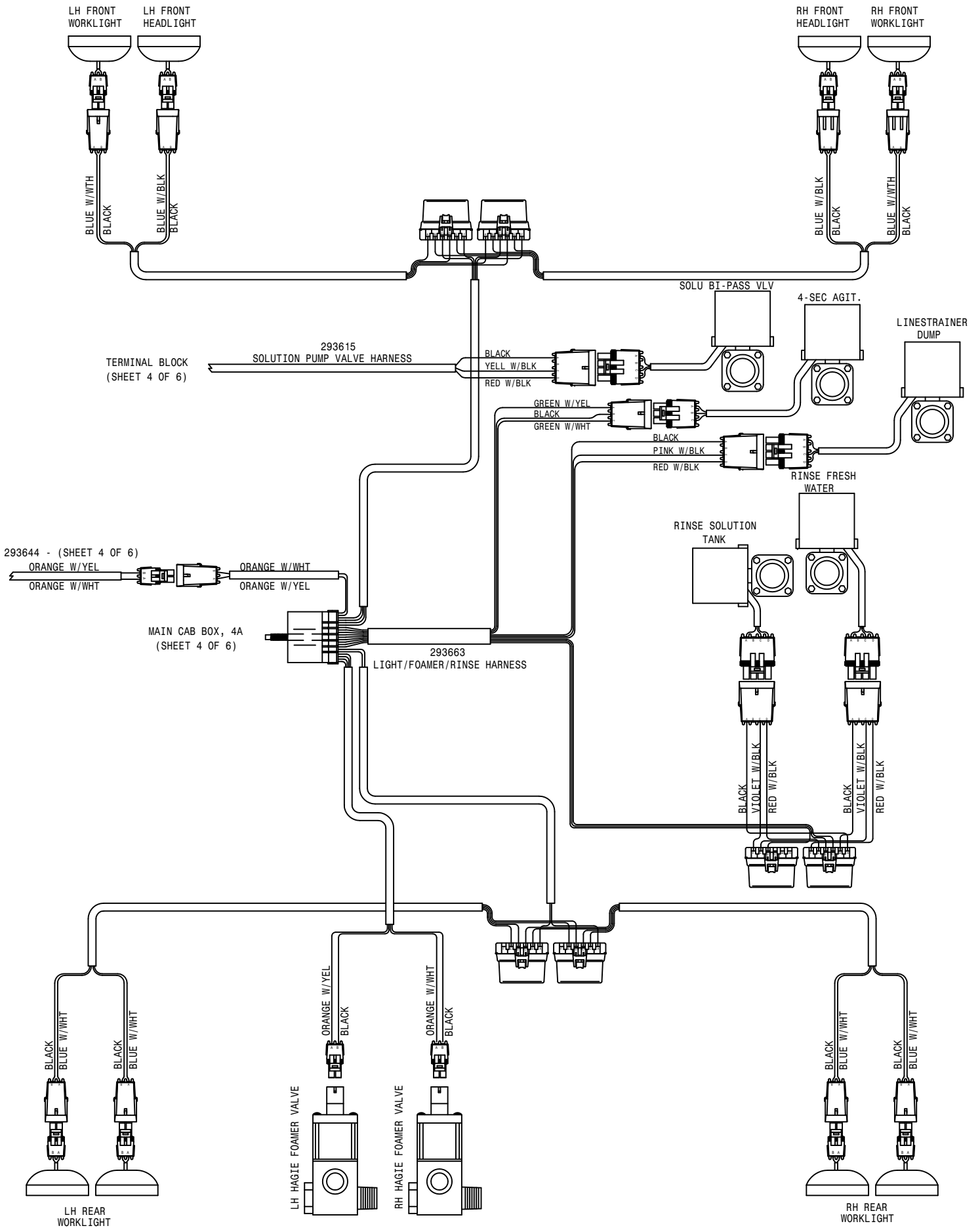

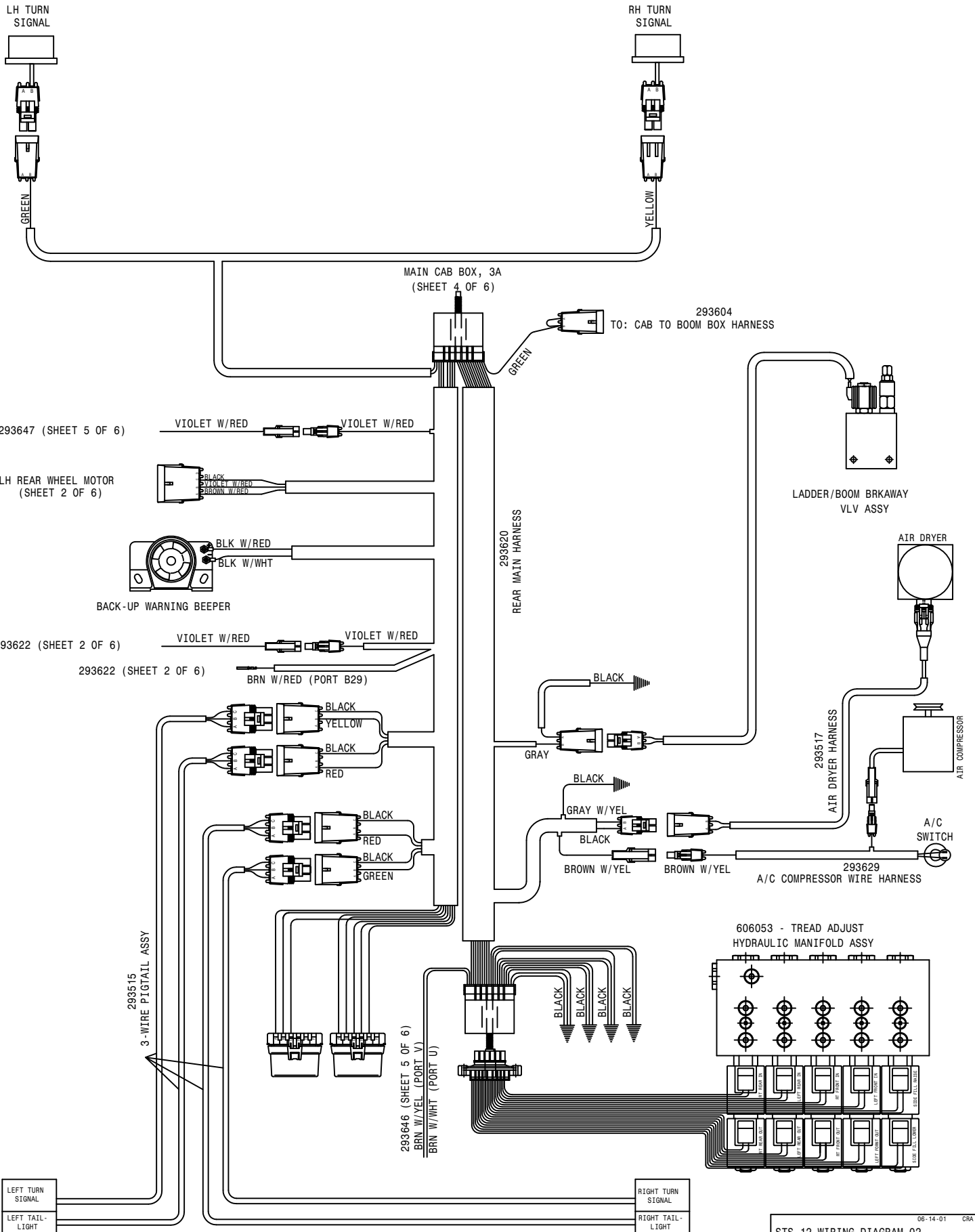

STS 12 WIRING DIAGRAM 02
 SHEET 3 OF 6
 REVISION DATE: 03-26-02
 498635
 06-14-01 CRA

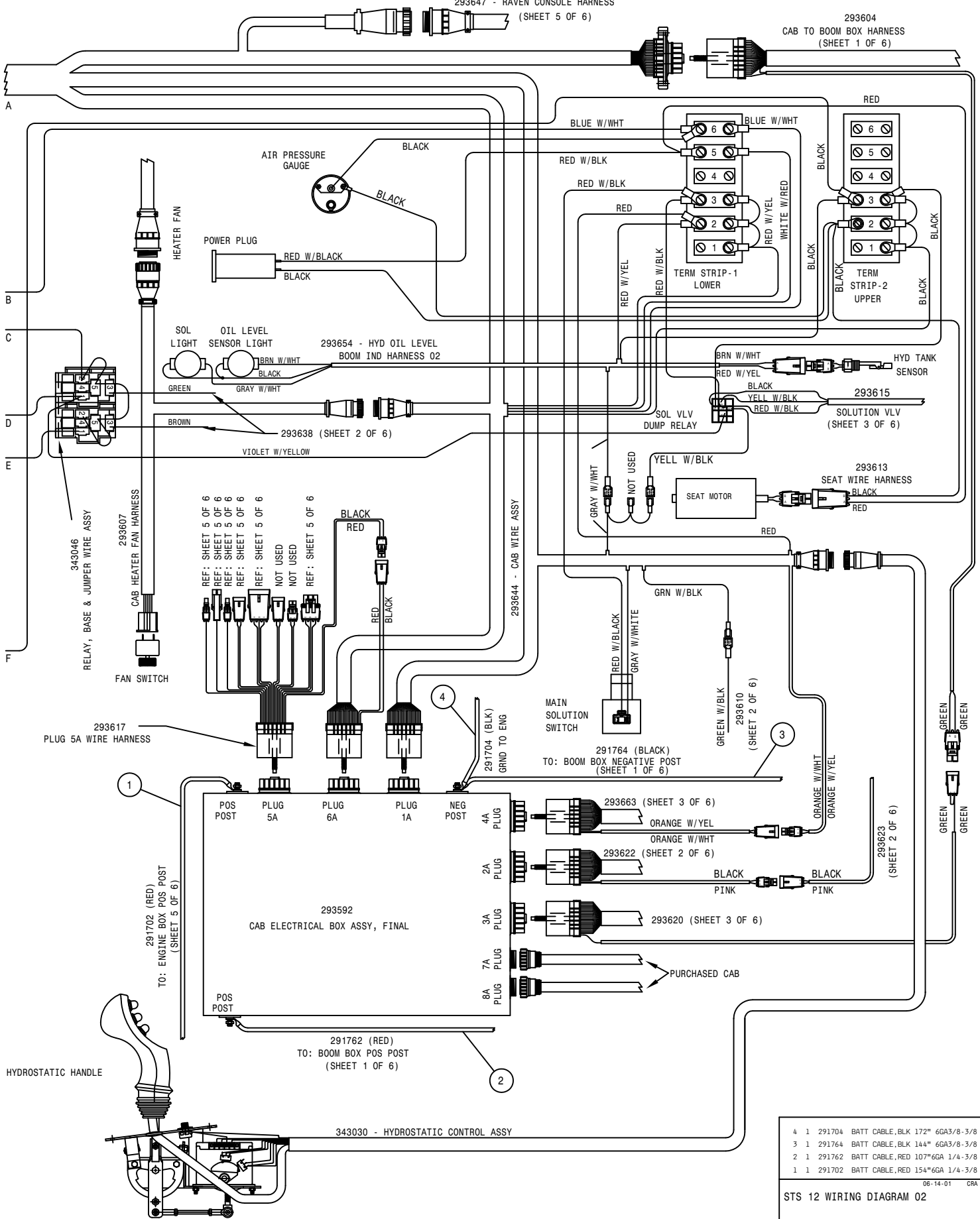

4	1	291704	BATT CABLE, BLK 172" 6GA3/8-3/8
3	1	291764	BATT CABLE, BLK 144" 6GA3/8-3/8
2	1	291762	BATT CABLE, RED 107" 6GA 1/4-3/8
1	1	291702	BATT CABLE, RED 154" 6GA 1/4-3/8

06-14-01 CRA

STS 12 WIRING DIAGRAM 02

SHEET 4 OF 6
REVISION DATE: 07-29-02

498635

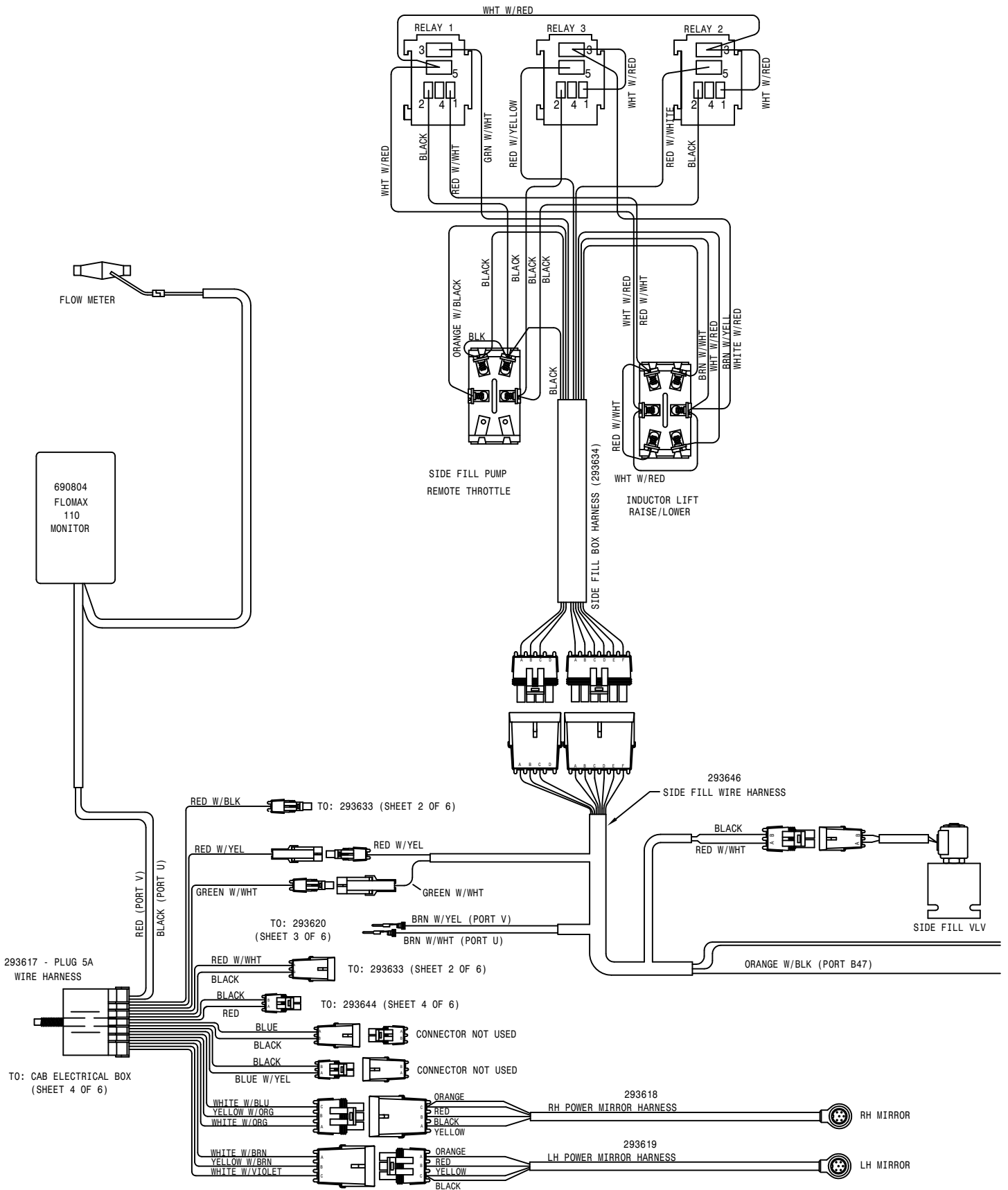

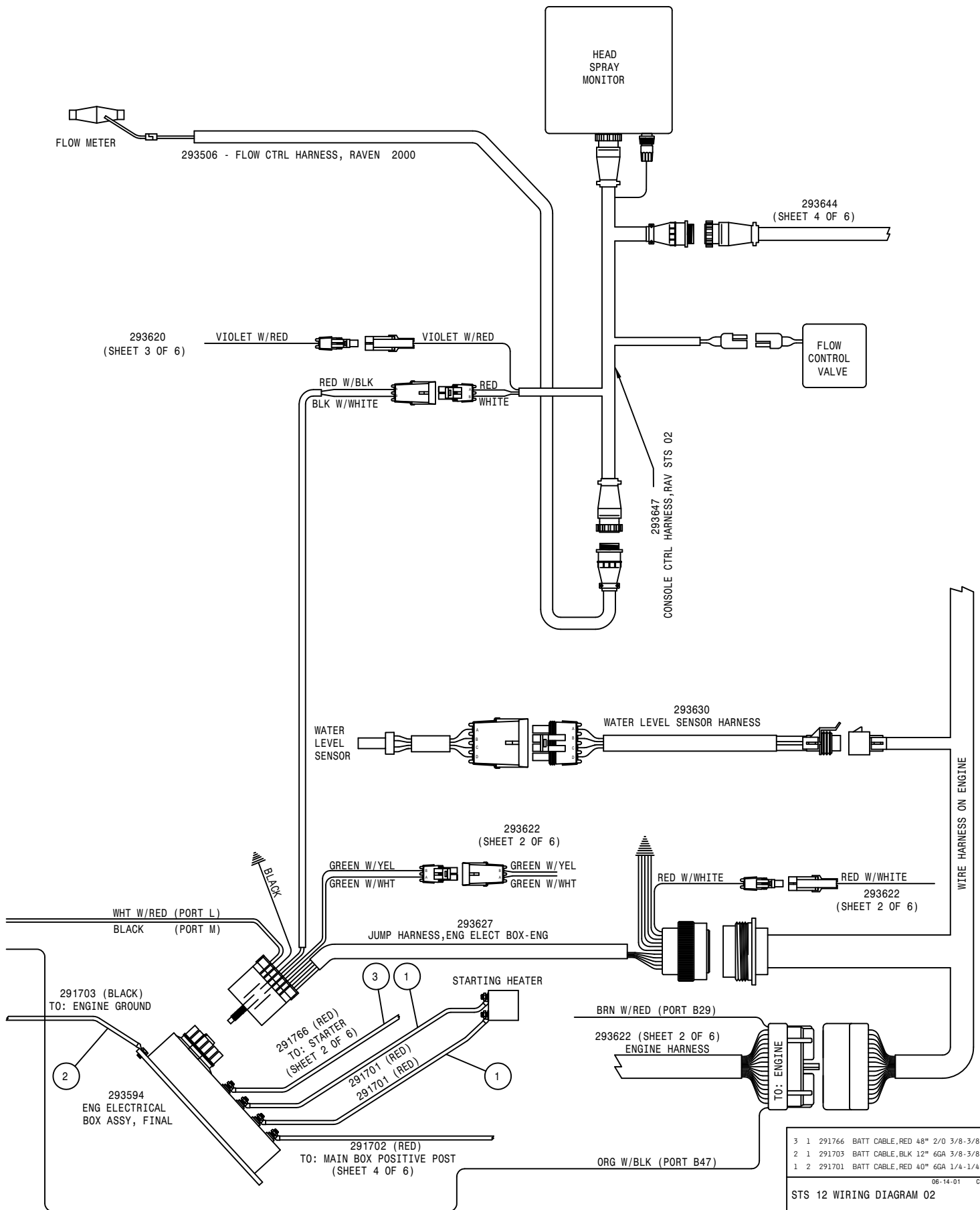

3	1	291766	BATT CABLE, RED 48" 2/0 3/8-3/8
2	1	291703	BATT CABLE, BLK 12" 6GA 3/8-3/8
1	2	291701	BATT CABLE, RED 40" 6GA 1/4-1/4

08-14-01 GRA

STS 12 WIRING DIAGRAM 02

SHEET 5 OF 6
REVISION DATE: 12-20-01

498635

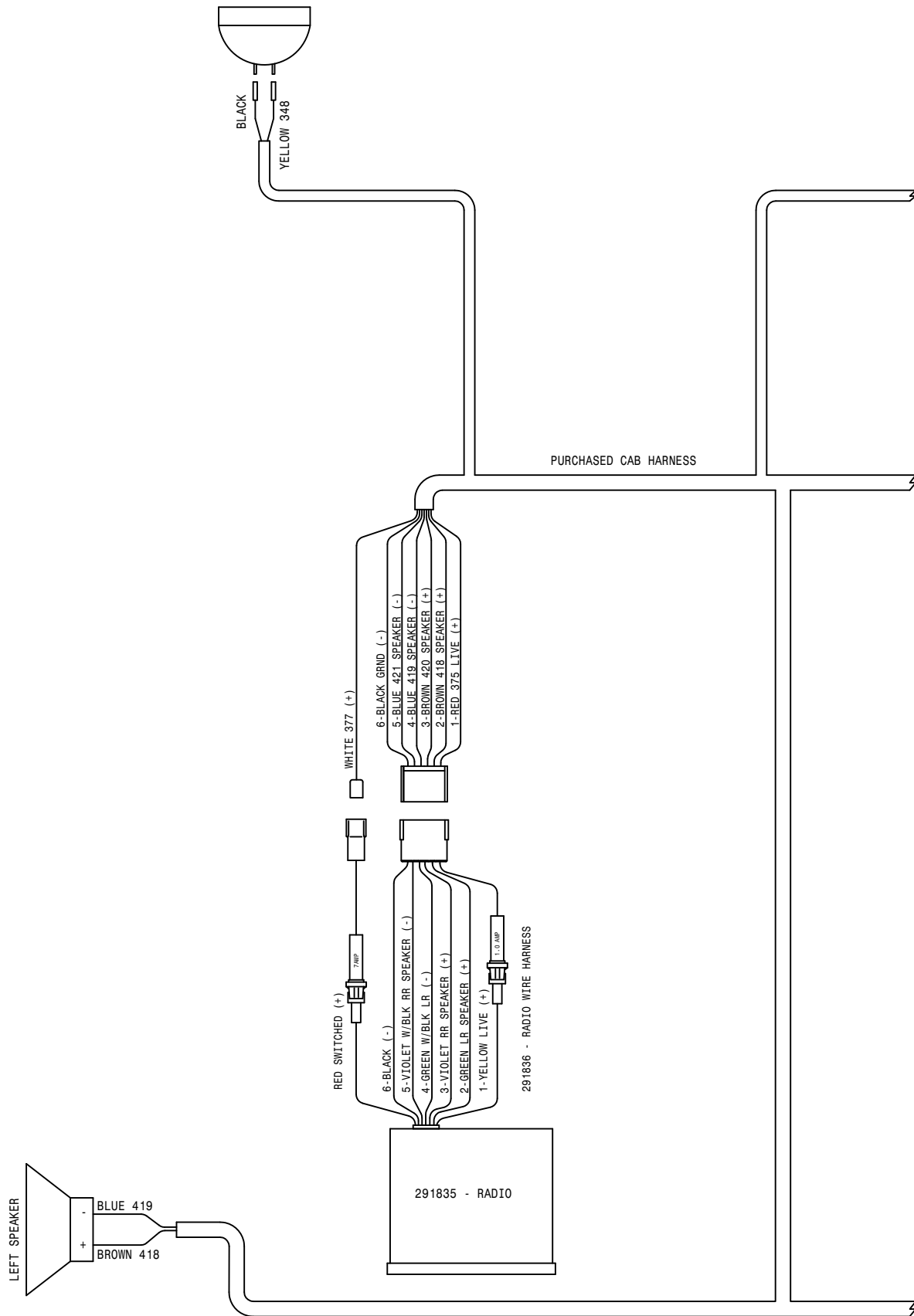

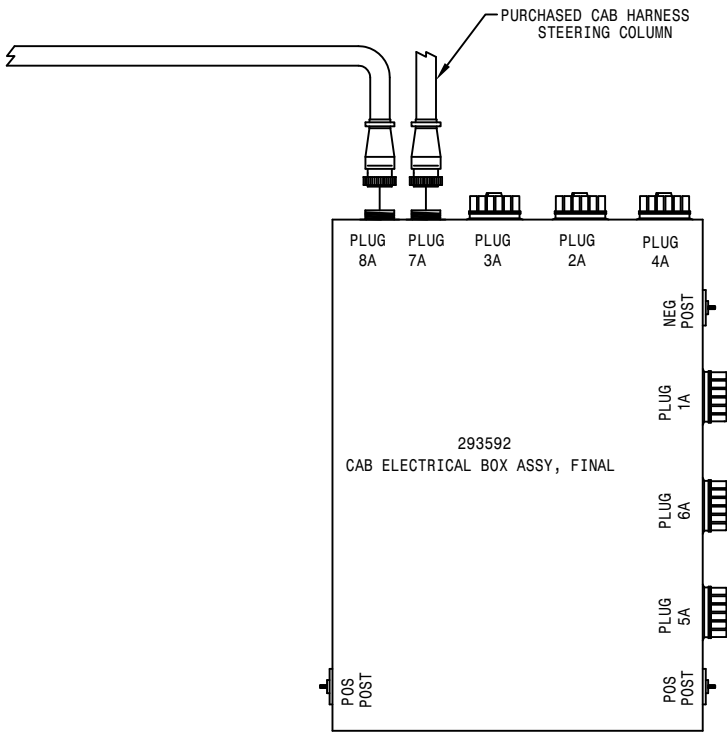

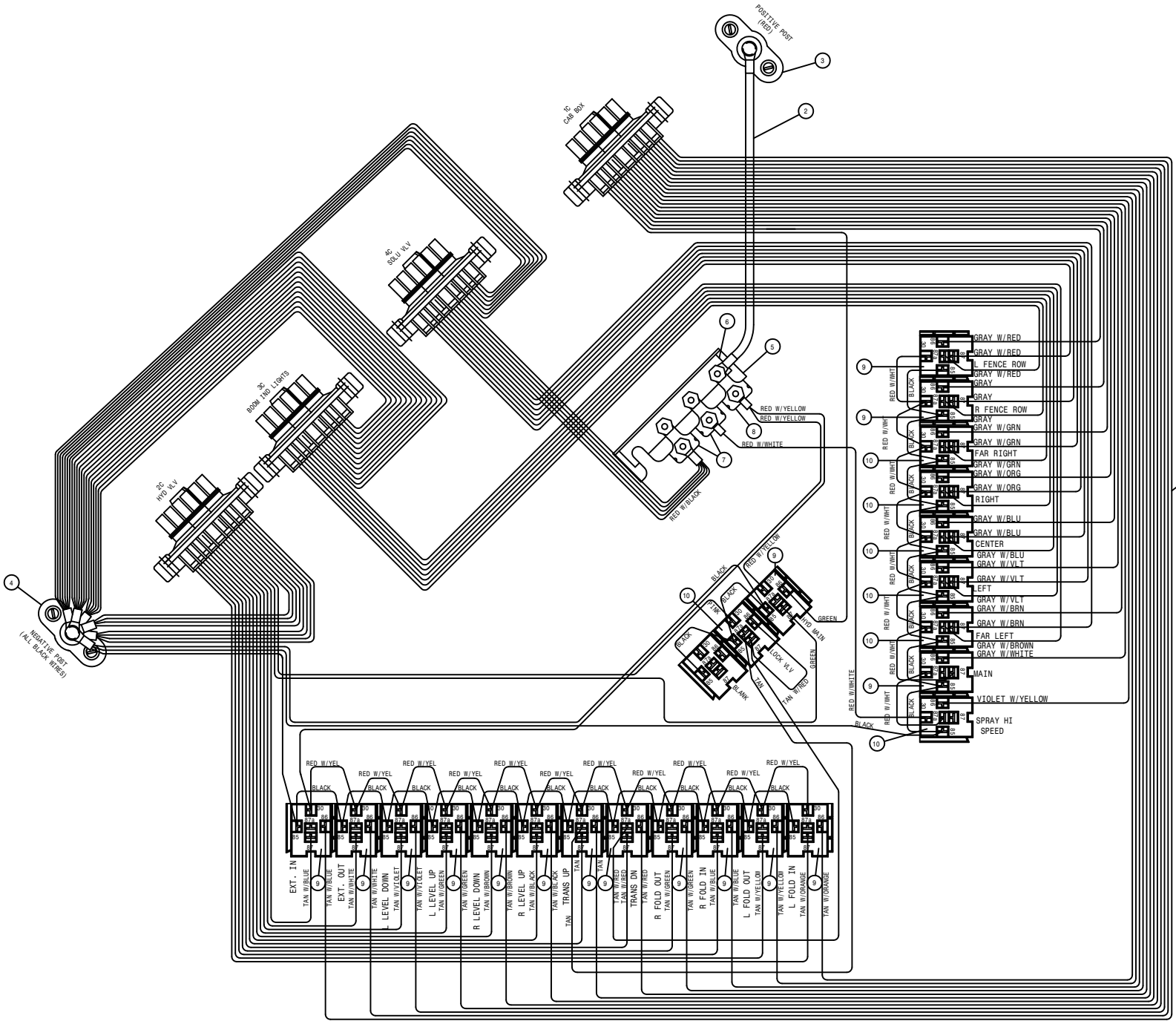

10	7	291752	RELAY, SPDT 12V 50A-NO 5-TERM BOSH 0332 209 137
9	16	291751	RELAY, SPST 12V 40A-NO, DIODE BOSH 0332 019 155
8	1	291573	CIRCUIT BREAKER, 20AMP W/O MT
7	2	291574	CIRCUIT BREAKER, 30AMP W/O MT
6	1	291756	BUS BAR, 4-GANG FOR 291755
5	2	291755	BREAKER MTG BRKT, 4-GANG NYLON
4	1	291749	TERM BLOCK, BLACK, 3/8-16 THRU
3	1	291750	TERM BLOCK, RED, 3/8-16 THRU
2	1	291803	BATT CABLE, RED 9"6GA.218-.250
1	1	293600	BOOM CTRL BOX HARNESS (342829)

DET	REQ	DESCRIPTION
HAGIE		
HAGIE MANUFACTURING COMPANY		
CLARION, IOWA 50525		
REMOVE ALL SHARP CORNERS & BURRS		
TOLERANCE UNLESS OTHERWISE SPECIFIED		
FRACTION ± 1/32 DECIMALS X.XX ± 0.03 X.XXX ± 0.005 ANGLES ± °		
DESCRIPTION OFF-SITE PARTS/ASSY FOR 293590		
DRAWN BY C. ADAMS		SCALE NONE (1)
CHECKED BY		APPROVED BY
DATE 01-18-00	DRAWING NUMBER 293591	
SHEET	OF	

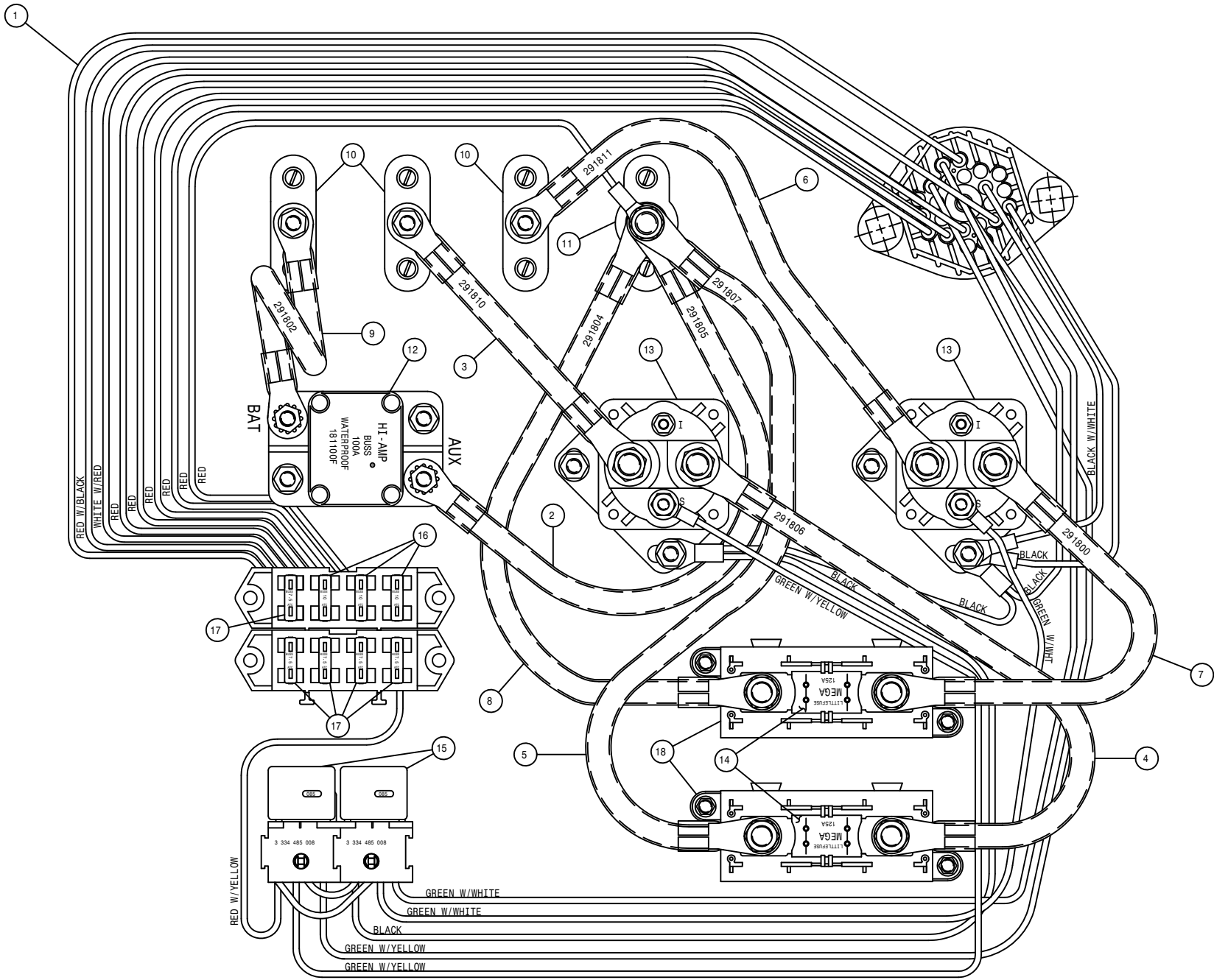

18	2	291814	FUSE HOLDER, HIGH AMP
17	5	291027	7.5 AMP FUSE, 1/4"BLADE ATD/ATC
16	3	291545	10 AMP FUSE, 1/4"BLADE ATD/ATC
15	2	291751	RELAY, SPST 12V 40A-ND 5-TERM
14	2	291813	125 AMP FUSE
13	2	291816	SOLENOID
12	1	291815	CIRCUIT BREAKER, 100 AMP BUSS
11	1	291750	TERM BLOCK, RED, 3/8-16 THRU
10	3	291748	TERM BLOCK, BLACK, 1/4-20 THRU
9	1	291802	BATT CABLE, RED 8*6GA. 281-.281
8	1	291804	BATT CABLE, RED 9*6GA. 343-.406
7	1	291800	BATT CABLE, RED 6*6GA. 343-.343
6	1	291811	BATT CABLE, BLK 8*6GA. 281-.343
5	1	291807	BATT CABLE, RED 12*6GA. 343-.406
4	1	291806	BATT CABLE, RED 11*6GA. 343-.343
3	1	291810	BATT CABLE, BLK 5*6GA. 281-.343
2	1	291805	BATT CABLE, RED 11*6GA. 281-.406
1	1	293626	ENGINE BOX HARNESS (342850)

SET	REQ	DESCRIPTION
HAGIE		
HAGIE MANUFACTURING COMPANY		
CLARION, IOWA 50525		
REMOVE ALL SHARP CORNERS & BURRS		
TOLERANCE UNLESS OTHERWISE SPECIFIED		
FRACTION	± 1/32	DECIMALS
		± .005
DESCRIPTION	OFF-SITE PARTS/ASSY FOR 293594	SCALE
DRAWN BY	C. ADAMS	NONE (1)
CHECKED BY		APPROVED BY
DATE	01-20-00	SHIPPING NUMBER
SHEET	OF	293595

ABBREVIATIONS

A/C - AIR CONDITIONER	MT - MOUNT
ADPTR - ADAPTER	MTR - MOTOR
AGI - AGITATOR	P/N - PART NUMBER
ALT - ALTERNATOR	PLT - PLATE
ASSY - ASSEMBLY	QTY - QUANTITY
BRKT - BRACKET	RED - REDUCER
DET - DETAIL	REF - REFERENCE
DISPL - DISPLACEMENT	REST - RESTRICTOR
EL - ELBOW	REQ - REQUIRED
EXT - EXTENSION	SHFT - SHAFT
FLO - FLOW	SOL - SOLUTION
FNPT - FEMALE NATIONAL PIPE THREAD	STRG - STEERING
FOR - FEMALE O-RING	ST - STREET
FRT - FRONT	SWIV - SWIVEL
HYD - HYDRAULIC	UNC - UNIFIED NATIONAL COURSE
HYDRO - HYDROSTATIC	UNF - UNIFIED NATIONAL FINE
LG - LONG	V - VOLT
LWR - LOWER	W/ - WITH
MJIC - MALE J.I.C.	WHL - WHEEL
MOR - MALE O-RING	WLD - WELDMENT

INDEX

-A-

ABBREVIATIONS.....141
ABSORBER, SHOCK.....42
ACCUMULATOR.....91
AIR DRYER.....13
AIR CLEANER.....10
 FILTER.....10
AIR COMPRESSOR GOVERNOR.....10
AIR CONDITIONER
 BINARY SWITCH.....9
 COMPRESSOR.....7
 CONDENSOR COIL.....12
 HOSE.....9,12
 RECEIVER/DRYER.....9
 TUBE.....31
AIR COOLER, CHARGE.....12
AIR PRESSURE GAUGE.....43,82
AIR REGULATOR, FOAMER.....82
AIRRIDE SPRING.....20,22,24,26,42
AIR VALVE.....20,22,24,26,42,
ALTERNATOR.....5
ARM, STEERING.....20,22,24,26
ATI CONTROLER.....48

-B-

BACK-UP BEEPER.....12
BALL VALVE.....55,65
 ELECTRIC..57,58,59,60,61,62,67
BATTERY.....16
 CABLE.....4,5,10,16
 BOX PANEL.....12
BEARING,
 BRONZE LEG.....20,22,24,26,32
 ORKOT.....20,22,24,26
BELT,
 AIR CONDITIONER.....7
 DRIVE.....5
BLOCK, TERMINAL.....43
BOOM.....92,93,94,95
 CRADLE.....49,96,97
 INDICATOR LIGHT.....87
 PIN.....94,95,96
 SWITCH.....47
 VALVE.....88,89
BOX,
 ELECTRICAL.....39,40,41
 PRESSURE WASHER.....103
 SIDE FILL.....109
BRACE, RADIATOR.....9
BREAKAWAY CYLINDER.....95,102
BUMPER, REAR.....53

-C-

CAB.....42
 FILTER.....42
 STABILIZER.....42
CABLE BATTERY.....4,5,10,16
CAP,
 FUEL.....14
 RADIATOR.....12
CHARGE AIR COOLER.....12
CHEMICAL INDUCTOR.....110
COMPRESSOR, A/C.....7
CONDENSOR COIL, A/C.....12
CONTROLER, ATI.....48
COOLER, OIL.....12
CRADLE, BOOM.....49,96,97
CYLINDER,
 BREAKAWAY.....95,102
 FOLD.....91,94,99,101
 GAS.....52
 LEVEL.....91,100
 LADDER.....36,37
 LIFT.....90,98
 SIDE FILL.....110
 STEERING.....20,22,28
 TREAD ADJUST.....32,33

-D-

DECALS.....116,117
DIAGRAMS, WIRING.....126
DIPSTICK, HYDRAULIC.....15
DOOR LATCH.....52
DRAIN COCK, AIR.....38
DRIVE
 BELT.....5
 DISK.....4

-E-

ELECTRIC BALL VALVE...58,59,60,61
ELECTRICAL BOX,
 BOOM.....39
 CAB.....41
 ENGINE.....40
ENGINE.....4,5
 SKID.....9

-F-

FAN.....5
 SPACER.....5

FEEDER TEE.....63,64,69,70
 FENCE ROW NOZZLE.....74,75
 FENDER.....114,115
 FILTER,
 AIR CLEANER.....10
 CAB.....42
 FUEL.....4
 HYDRAULIC.....17,34
 MINDER.....10
 OIL.....5,15
 FLASHER.....30,53
 FLOW METER.....61,67
 FOAMER
 AIR REGULATOR.....82
 DROP HOSE.....86
 HOSING.....80
 TANK.....81
 THREE-WAY VALVE.....81
 VALVE.....81
 FOLD CYLINDER.....91,94,99
 FRAME, SHEETMETAL.....53
 FRESH WATER.....83
 FRONT FILL.....112
 FUEL,
 CAP.....14
 SENDER.....14
 TANK.....14

-G-

GAS CYLINDER.....52
 GAUGE,
 AIR PRESSURE.....43,82
 SOLUTION.....61,67

-H-

HANDRAIL.....54
 HEATER TUBE.....31
 HOSE, A/C.....9
 HOSING,
 FOAMER.....80
 SOLUTION.....76,77,78,79
 HUB, TORQUE.....21,23,25,27
 HYDRAULIC,
 FILTER.....17
 LEVER.....45
 SCHEMATIC.....118
 TANK.....15
 TUBE.....30,31,90,93
 VALVE.....18,19
 HYDROSTATIC PUMP.....8

-I-

IGNITION SWITCH.....46
 INDICATOR LIGHT, BOOM.....87
 INLINE, HYDRAULIC FILTER.....34

-L-

LADDER.....36
 CYLINDER.....36,37
 PIVOT ARM.....36
 LEG.....20,22,24,26
 LEVEL CYLINDER.....91,100
 LEVER, HYDROSTATIC.....45
 LIFT CYLINDER.....90,98
 LIFTARM.....90
 LIGHT.....30,49
 LINE STRAINER.....56,57,60
 LIQUID LEVEL SWITCH.....15

-M-

MIRROR.....50,51
 MONITOR, SPRAYER.....48
 MOTOR,
 STEERING.....42
 WHEEL.....21,23,25,27
 MOUNT, RUBBER.....9,12
 MUFFLER.....11

-N-

NOZZLE,
 BODY.....73
 FENCE ROW.....74,75
 MOUNT TUBE.....93,94,95
 REAR WHEEL.....66,72

-O-

OIL COOLER.....12
 OIL FILTER.....5,15

-P-

PANEL,
 BATTERY BOX.....12
 SWITCH.....46
 PLATFORM, SERVICE.....54
 PRESSURE GAUGE.....61,67
 PRESSURE WASHER.....104
 BOX.....103
 VALVE.....106,107
 PUMP,
 HYDRAULIC.....6
 HYDROSTATIC.....8
 SIDE FILL.....110,111
 SOLUTION.....58

-R-

RADIATOR.....12
 BRACE.....9
 CAP.....12
 HOSE.....5

RADIO.....44
 REAR WHEEL NOZZLE.....66,72
 RECOVERY TANK.....52
 RINSE TANK.....56,57
 RUBBER
 MOUNT.....9,12
 SPRING.....20,22,24,26

-S-

SCHEMATIC, HYDRAULIC.....118
 SENDER, FUEL.....14
 SENDER, WATER LEVEL.....12
 SEVICE PLATFORM.....54
 SHEET METAL.....52,53
 SHIELD, WHEEL MOTOR...21,23,25,27
 SHOCK ABSORBER.....42
 SIDFILL.....110,111
 BOX.....109
 CYLINDER.....110,111
 SIGHT GAUGE, OIL.....15
 SKID, ENGINE.....9
 SMV SIGN.....53
 SOLUTION
 HOSING.....76,77,78,79
 PUMP.....58
 TANK.....55
 VALVE.....61,62,67
 SPACER, FAN.....5
 SPEAKER.....44
 SPRAY MONITOR.....48
 SPRING,
 AIRRIDE.....20,22,42
 SOLUTION TANK.....55
 STABILIZER, CAB.....42
 STARTER.....5
 STEERING,
 ARM.....20,22,24,26
 CYLINDER.....20,22,28
 MOTOR.....42
 STRAINER, LINE.....56,57,60
 SWITCH,
 A/C BINARY.....9
 IGNITION.....46
 LIQUID LEVEL.....15
 PANEL.....46

-T-

TAILLIGHT.....53
 TANK
 AIR.....38
 FOAMER.....81
 FRESHWATER.....83
 FUEL.....14

HYDRAULIC.....15
 RECOVERY.....52
 RINSE.....56,57
 SOLUTION.....55
 TERMINAL BLOCK.....43
 TIRE.....29
 TORQUE HUB.....21,23,25,27
 TRANSOM.....91
 TREAD ADJUST
 CYLINDER.....32,33
 VALVE.....34,35
 TUBE,
 A/C.....31
 HEATER.....31
 HYDRAULIC.....30,31,90,93

-V-

VALVE,
 AIR.....20,22,24,26,42
 BALL.....55,65
 BOOM.....88,89
 ELECTRIC BALL...57,58,59,61,67
 FOAMER.....81,84,85
 HYDRAULIC.....9,18
 PRESSURE WASHER.....106,107
 SIDE FILL.....101,108
 SOLUTION.....61,62,65
 TREAD ADJUST.....34,35

-W-

WASHER, PRESSURE.....104
 WATER LEVEL SENSOR.....12
 WHEELMOTOR.....21,23,25,27
 SHIELD.....21,23,25,27
 WIRING DIAGRAM.....126



PARTS ORDER FAX

Fax
24 hours
a day
7 days
a week*

Ph. 1 (800) 247-4885

Fx. 1 (515) 532-3553

Photocopy and fax to Hagie Customer Support Department

ORDERED BY/BILL TO:

Name _____
 Co. Name _____
 Street _____
 City, St, Zip _____
 Ph. _____ Fx. _____

SHIP TO:

Name _____
 Co. Name _____
 Street _____
 City, St, Zip _____
 Ph. _____ Fx. _____

HOW SHIP: UPS Ground Next Day 2 Day 3 Day Other _____

If "HOW SHIP" is left blank, parts will be sent UPS ground service. If part is over 150 pounds, an independent motor freight company will be used.

PAYMENT: Hagie Account #** _____
 C.O.D

American Express Discover Visa Master Card

Signature: _____
 name as appears on card: _____
 card no. _____ exp. date _____

Year and Model No. _____

Serial No. _____

Item Serial No. (if necessary):

Engine (include type) _____

Hydrostatic Pump (s) _____

Torque Hub _____ LF RF LR RR

Wheel Motor _____ LF RF LR RR

HAGIE Part No.	Qty.	Description

Check here if you want phone confirmation of parts order.

* Orders received before 3:00 p.m., CST will be processed the same business day.
 Regular business hours are Monday through Friday, 7:00 a.m. through 5:00 p.m..

** If you do not have a Hagie account number, contact the Hagie Customer Support Department and you will be issued one.



PARTS ORDER FAX

Fax
24 hours
a day
7 days
a week*

Ph. 1 (800) 247-4885

Fx. 1 (515) 532-3553

Photocopy and fax to Hagie Customer Support Department

ORDERED BY/BILL TO:

Name _____
 Co. Name _____
 Street _____
 City, St, Zip _____
 Ph. _____ Fx. _____

SHIP TO:

Name _____
 Co. Name _____
 Street _____
 City, St, Zip _____
 Ph. _____ Fx. _____

HOW SHIP: UPS Ground Next Day 2 Day 3 Day Other _____

If "HOW SHIP" is left blank, parts will be sent UPS ground service. If part is over 150 pounds, an independent motor freight company will be used.

PAYMENT: Hagie Account #** _____
 C.O.D

American Express Discover Visa Master Card

Signature: _____
 name as appears on card: _____
 card no. _____ exp. date _____

Year and Model No. _____

Serial No. _____

Item Serial No. (if necessary):

Engine (include type) _____

Hydrostatic Pump (s) _____

Torque Hub _____ LF RF LR RR

Wheel Motor _____ LF RF LR RR

HAGIE Part No.	Qty.	Description

Check here if you want phone confirmation of parts order.

* Orders received before 3:00 p.m., CST will be processed the same business day.
 Regular business hours are Monday through Friday, 7:00 a.m. through 5:00 p.m..

** If you do not have a Hagie account number, contact the Hagie Customer Support Department and you will be issued one.