

# CALIFORNIA

## Proposition 65

WARNING: Diesel engine exhaust and some of its constituents are known to the State of California to cause cancer and birth defects or other reproductive harm.

WARNING: Battery posts, terminals, and related accessories contain lead and lead compounds, chemicals known to the State of California to cause cancer and birth defects or other reproductive harm.



ANY PICTURES CONTAINED WITHIN THIS OPERATOR'S MANUAL THAT DEPICT SITUATIONS WITH SHIELDS, GUARDS, RAILS, OR LIDS REMOVED ARE FOR DEMONSTRATION PURPOSES ONLY. HAGIE MANUFACTURING COMPANY STRONGLY URGES THE OPERATOR TO KEEP ALL SHIELDS AND SAFETY DEVICES IN PLACE AT ALL TIMES.

# **HAGIE**

## **MODEL STS 12**

### **DETASSELER OPTION**

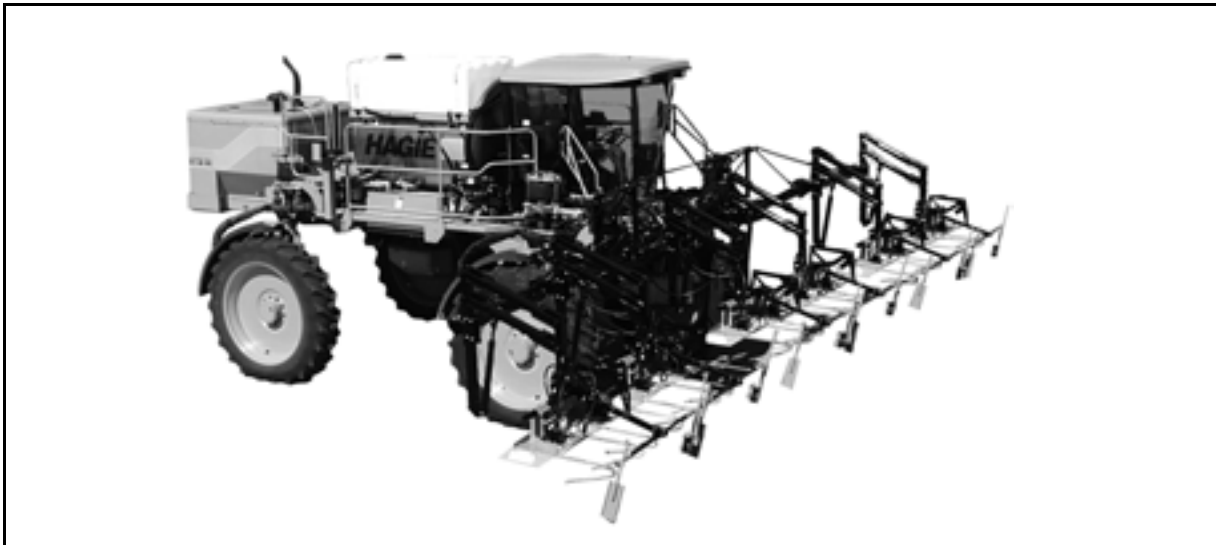

**OPERATOR'S MANUAL SUPPLEMENT FOR  
HAGIE MODEL STS 12  
SPRAYER/DETASSELER**

**HAGIE MANUFACTURING COMPANY**

BOX 273 CLARION, IOWA 50525

(515) 532-2861

COVERS MACHINE SERIAL NUMBERS:U1650220001 thru U1650220100

06-02 493255

# ABBREVIATIONS

A/C .....	AIR CONDITIONING	MT .....	MOUNT
ADJ .....	ADJUST	MTH .....	MONTH
ADPTR .....	ADAPTER	MTR .....	MOTOR
ALT .....	ALTERNATOR	NO .....	NUMBER
AMP .....	AMPERE	OD .....	OUTSIDE DIAMETER
APPROX .....	APPROXIMATELY	PLT .....	PLATE
ASSY .....	ASSEMBLY	PRESS .....	PRESSURE
AUX .....	AUXILIARY	PRKNG .....	PARKING
BRKT .....	BRACKET	PSI .....	POUNDS PER SQUARE INCH
BTRY .....	BATTERY	QT .....	QUART
C .....	CELSIUS	RAD .....	RADIATOR
CCA .....	COLD CRANKING AMPS	REC .....	RECOMMENDED
CTRL .....	CONTROL	REQ .....	REQUIRED
CYL .....	CYLINDER	RPM .....	REVOLUTIONS PER MINUTE
DIAG .....	DIAGRAM	SAE .....	SOCIETY of AUTOMOTIVE ENGINEERS
DIM .....	DIMENSION	SEC .....	SECOND
DISPL .....	DISPLACEMENT	SERV .....	SERVICE
EA .....	EACH	SLCTR .....	SELECTOR
ELECT .....	ELECTRIC	SMV .....	SLOW MOVING VEHICLE
F .....	FAHRENHEIT	SOLE .....	SOLENOID
FIG .....	FIGURE	SPEC .....	SPECIFICATION
FLO .....	FLOW	STRG .....	STEERING
FRT .....	FRONT	SQ .....	SQUARE
FT .....	FOOT OR FEET	TACH .....	TACHOMETER
GA .....	GAUGE	TEMP .....	TEMPERATURE
GAL .....	GALLON	TERM .....	TERMINAL
HAL .....	HALOGEN	TRD .....	TREAD
HR .....	HOUR	TT .....	TUBE-TYPE
HYD .....	HYDRAULIC	TU .....	TUBELESS
HYDRO .....	HYDROSTATIC	VAR .....	VARIABLE
ID .....	INSIDE DIAMETER	V .....	VOLT
IN .....	INCH	VLV .....	VALVE
INFO .....	INFORMATION	W .....	WEIGHT
Km/H .....	KILOMETERS PER HOUR	WD .....	WHEEL DRIVE
LB .....	POUND	W/ .....	WITH
LS .....	LIGHT SENSOR	W/O .....	WITHOUT
MAINT .....	MAINTENANCE	WHL .....	WHEEL
MIN .....	MINUTE	WK .....	WEEK
M/F .....	MAINFRAME	WLD .....	WELDMENT
MPH .....	MILES PER HOUR		

# TO THE OWNER

---

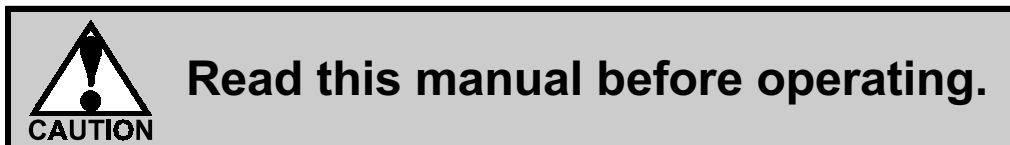

## A WORD FROM HAGIE MANUFACTURING COMPANY

Congratulations on your selection of a Hagie Model STS 12 SPRAYER/DETASSELER. This operator's manual supplement is not intended to stand alone as an operating manual for the STS 12 SPRAYER/DETASSELER, but is considered an additional support publication for your STS 12 Operator's Manual to encompass the detasseling options. We recommend that you study your STS 12 Operator's Manual along with this supplement and become acquainted with the adjustments and operating procedures before attempting to operate your new sprayer/detasseler. As with any piece of equipment, certain operating procedures, service, and maintenance are required to keep it in top running condition.

We have attempted herein to cover all of the adjustments required to fit varying conditions. However, there may be times when special care must be considered.

Hagie Manufacturing Company reserves the right to make changes in the design and material of any subsequent sprayer/detasseler without obligation to existing units.

We thank you for choosing a Hagie SPRAYER/DETASSELER and assure you of our continued interest in its satisfactory operation for you. If we might be of assistance to you, please call us.

We are proud to have you as a customer.



# CAUTION

READ OPERATOR'S MANUAL. BE ALERT. LEARN TO OPERATE THIS MACHINE SAFELY. OBSERVE ALL SAFETY PRACTICES. MACHINES CAN BE HAZARDOUS IN THE HANDS OF AN UNFAMILIAR, UNTRAINED, OR COMPLACENT OPERATOR. SHUT OFF ENGINE BEFORE SERVICING. WHEN MECHANISM BECOMES CLOGGED, SHUT OFF ENGINE BEFORE CLEANING. DON'T RISK INJURY OR DEATH.

## TO THE OPERATOR

The following pages and illustrations will help you operate and service your new sprayer/detasseler. It is the responsibility of the user to read the operator's manual and comply with the safe correct operating procedures and lubricate and maintain the product according to the maintenance schedule.

The user is responsible for inspecting the machine and having parts repaired or replaced when continued use of the product causes damage

or excessive wear to other parts.

Keep this manual in a convenient place for easy reference when problems arise. This manual is considered a permanent fixture with this machine. In the event of resale, this manual should accompany the sprayer/detasseler. If you do not understand any part of the manual or require additional information or service, contact the Hagie Customer Support Department:

Hagie Manufacturing Company  
Box 273, Clarion, IA 50525  
(515) 532-2861

The following symbols, found throughout this manual, alert you to potentially dangerous conditions to the operator, service personnel, or the equipment.



*This symbol indicates an immanently hazardous situation which, if not avoided, will result in death or serious injury.*



*This symbol indicates a potentially hazardous situation which, if not avoided, could result in death or injury.*



*This symbol indicates a potentially hazardous situation which, if not avoided, may result in minor or moderate injury. It may also be used to alert against unsafe practices.*

# TABLE OF CONTENTS

I. SAFETY/DECALS.....	4-6
II. PREPARING TO OPERATE.....	7-8
IV. OPERATING INFORMATION .....	9-18
V. SERVICE AND MAINTENANCE.....	19-21
VI. TROUBLE SHOOTING.....	22-32
VII. LIMITED WARRANTY .....	33
INDEX .....	34

SAFETY/DECALS

PREPARING  
TO OPERATE

OPERATING  
INFORMATION

SERVICE/  
MAINTENANCE

TROUBLE  
SHOOTING

LIMITED  
WARRANTY

INDEX

# I. SAFETY/DECALS

---

## SAFETY PRECAUTIONS

Most accidents occur as the result of failure to follow simple and fundamental safety rules. For this reason, most accidents can be prevented by recognizing the real cause and doing something about it before the accident occurs.

Many conditions cannot be completely safeguarded against without interfering with efficient operation and/or reasonable accessibility. Therefore, you must study your STS 12 Operator's

Manual along with this supplementary manual and learn how to use the sprayer/detasseler controls for safe operation. Likewise, do not let anyone operate without instruction.

Do not make modifications such as weldments, add-ons, adaptations, or changes from the original design of detasseler. Such changes and/or modifications may become safety hazards to you and to others and will void all warranties.



### OUTRIGGERS

- Make sure the outriggers are locked down either when folded in or folded out.

### GENERAL OPERATION SAFETY

- If equipped with light sensing depth units, do not look directly into light beam. It emits a very low intensity microwave signal which may cause possible eye damage.
- Never allow walking personnel in the same field as a detasseler.

# I. SAFETY/DECALS

## WARNING DECALS

Decals warning you of avoidable danger are located on various parts of the sprayer/detasseler. They are there for your personal safety and protection. DO NOT remove them. They will fracture upon attempted removal and therefore must be replaced.

Following are locations of important safety decals not shown in your STS 12 Operator's Man-

ual. Replace them if they are torn or missing. All warning decals and other instructional Hagie decals or machine striping may be purchased through the Hagie Customer Support Department. To replace decals, be sure that the installation area is clean and dry; decide on exact position before you remove the backing paper.

## DECAL LOCATION

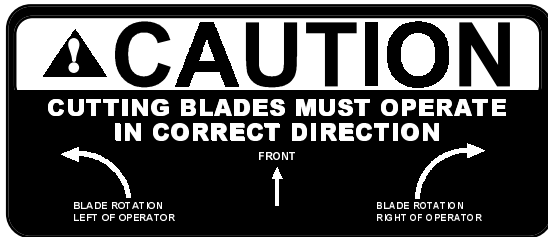

650303

Above door handle of left cab door.



650819

2 on each cutter housing.



DECALS CONTINUED →

SAFETY/DECALS

PREPARING  
TO OPERATE

OPERATING  
INFORMATION

SERVICE/  
MAINTENANCE

TROUBLE  
SHOOTING

LIMITED  
WARRANTY

INDEX



# I. SAFETY/DECALS



650820

Quad puller head.



650820

2 on each male corn chopper.

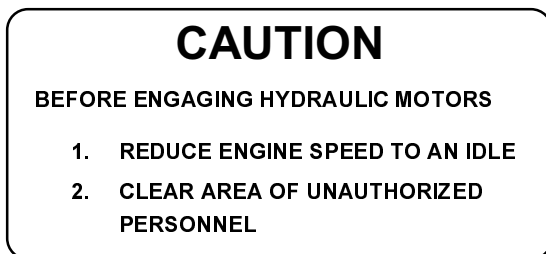
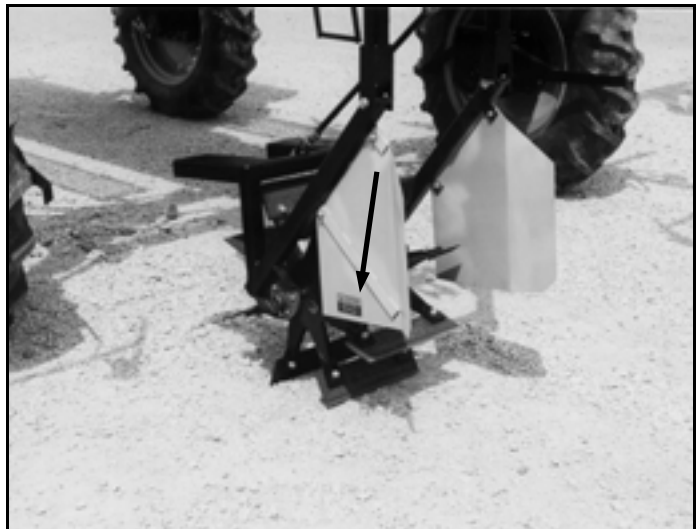

650955

Near motor control box on right cab glass.



## II. PREPARING TO OPERATE

### REMOVING SPRAY BOOMS

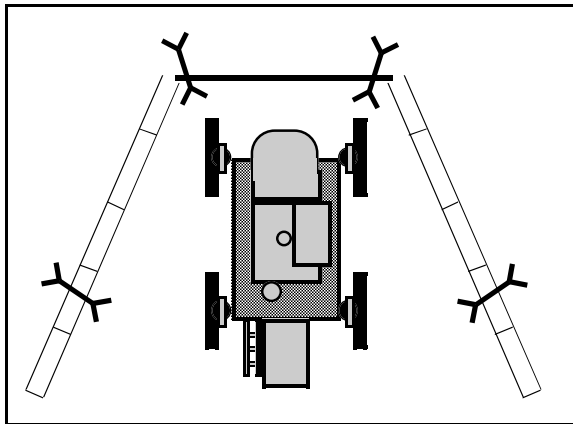

FIG 2.1

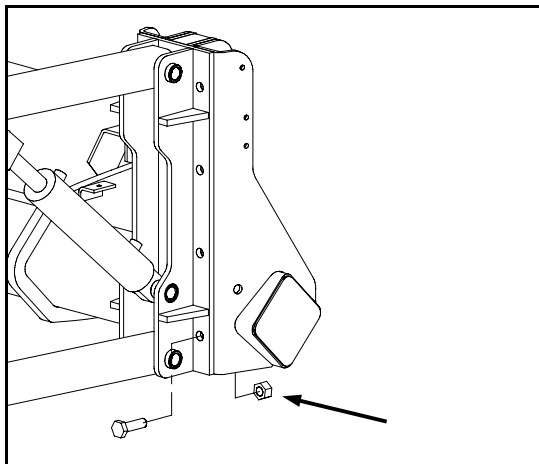

FIG 2.2

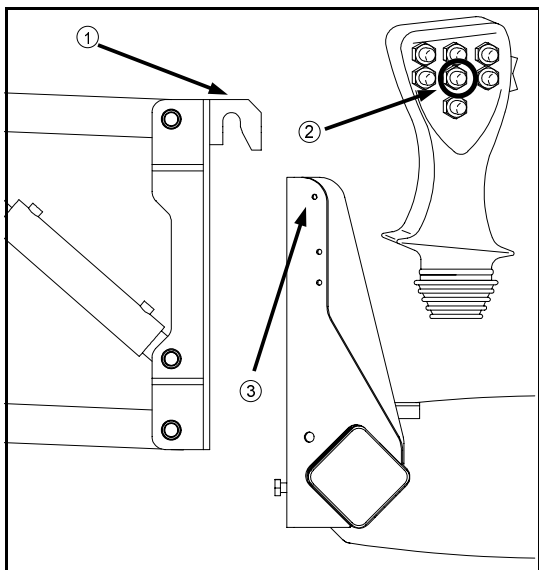

FIG 2.3

Park the sprayer on level ground and set the parking brake. To prepare the booms for removal, lift the booms out of the boom cradle, leaving the extensions folded in. Fold them out enough to clear the tractor when lowered. Lower the booms onto heavy-duty stands, supporting them in at least four places (fig. 2.1).

Disconnect solution supply quick-couples, foamer supply quick-couples and lift arm plate mounting bolts (item 2.2, 16 total).

After removing all 16 mounting bolts, with the booms resting on all four support stands, depress the lower transom button (fig. 2.3, item 2). This will cause the lift arm plate to raise. Continue pressing the button until the quick-attach “hook” has cleared the “quick-attach” pin (fig. 2.3, item 1 & 3).

Disconnect hydraulic breakaway hose quick-coupling. Cap each coupling after disconnection to prevent contamination of hydraulic circuit. Disconnect hydraulic supply to and return hose from boom control valve. Cap the hose coupling that stay with the boom. Connect the male and female hoses still on the tractor to each other until mounting the detasseling bar.

## II. PREPARING TO OPERATE

---

### Wiring Tasselrol<sup>®</sup>/LS and Depth Command

Attach Tasselrol<sup>®</sup>, Depth Command and other wire harnesses to the appropriate “jumper” ports located in front of the cab (fig. 2.4). Refer to also to STS 12 SPRAYER/DETASSELER Parts Manual

for proper wiring schematics.

All “jumper” ports not used should be “capped” (fig. 2.4, items 1) to protect connection points.

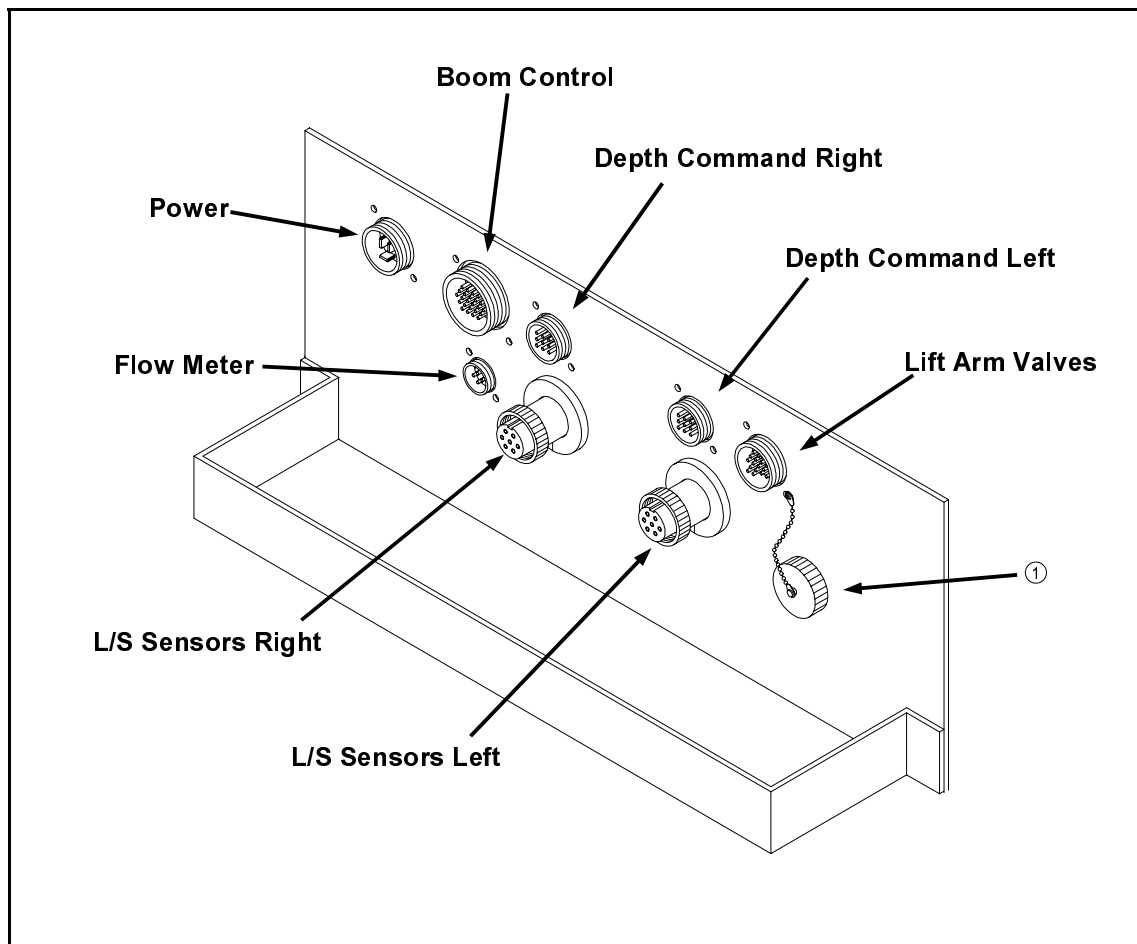

FIG 2.4

# III. OPERATING INFORMATION

## Detasseling Heads

The hydraulic motors on the detasseling heads (fig. 3.2) are turned on and off with a row of switches mounted on the control box to the right of the operator's seat (fig. 3.1). To activate the motors, depress the front or top of the corresponding switch(es). To shut any or all motors off, depress the back or bottom of the corresponding switch(es).

Each motor control valve contains a .182 inch orifice disc that restricts hydraulic flow to the hydraulic motors so they don't overspeed and become damaged.

Activate hydraulic motors while engine speed is at an idle, then increase engine RPM to operating speed.



FIG 3.1

**CAUTION**  
**BEFORE ENGAGING HYDRAULIC MOTORS**

1. REDUCE ENGINE SPEED TO AN IDLE
2. CLEAR AREA OF UNAUTHORIZED PERSONNEL

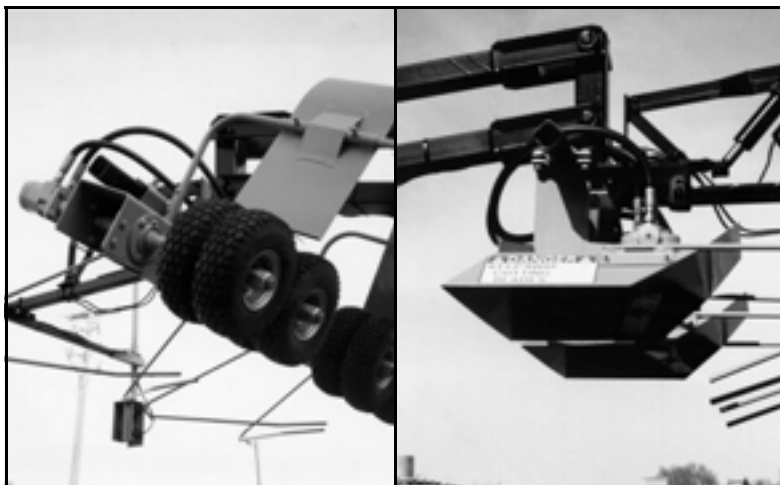

FIG 3.2

**CAUTION**  
DO NOT operate the hydraulic motors on detasseling heads without .182 inch orifices in place under each solenoid coil.

# III. OPERATING INFORMATION

## SETTING UP THE TASSELTROL®/LS SYSTEM

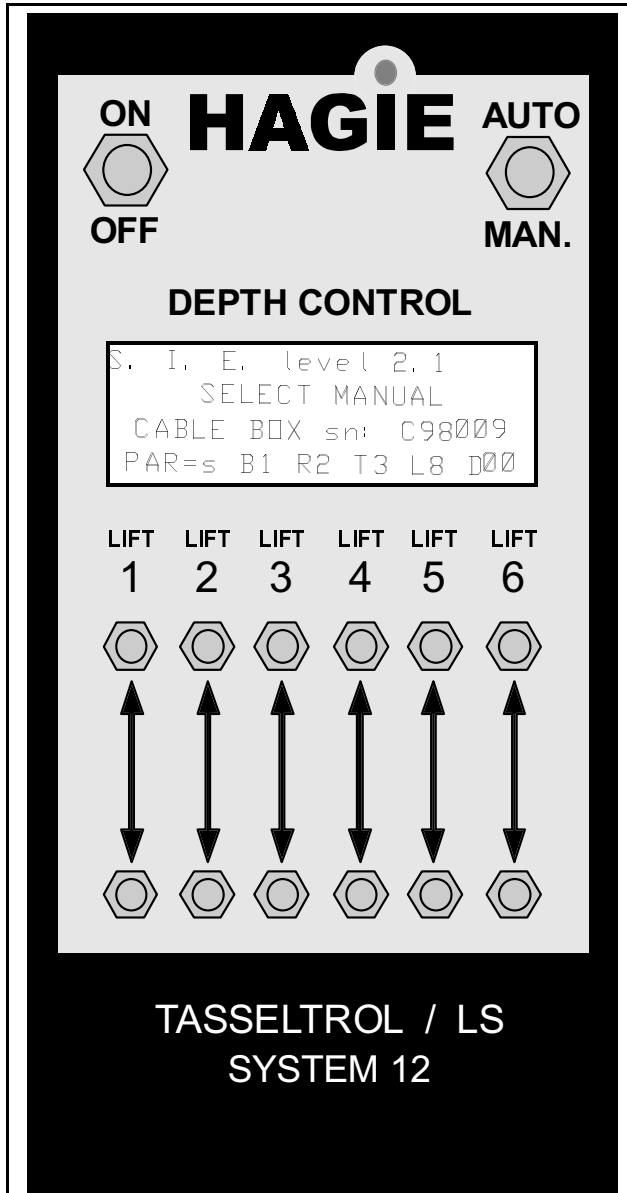

FIG 3.3

The control box (fig. 3.3) has three programmable parameters and each has four different value settings. Your programmable control box is factory preset with the following parameter defaults:

**BOTTOM PARAMETER – B1** See page 15 to reprogram the bottom parameter.

**RESPONSE PARAMETER – R2** See page 13 to reprogram the response parameter.

**TOP PARAMETER – T3** See page 14 to reprogram the top parameter.

These parameters will always be displayed until the control box is reprogrammed. Once reprogrammed, the values for the parameters will appear in the window of the control box. The new parameters will maintain their value for approximately a two week period. If the unit is not used within this time frame, the parameters will automatically return to the normal settings.

To program the unit, first select the response parameter (page 13). If further adjustment is required for top and/or bottom parameters, see pages 14 and 15.

# III. OPERATING INFORMATION

## OPERATING THE TASSELTROL®/LS CONTROL

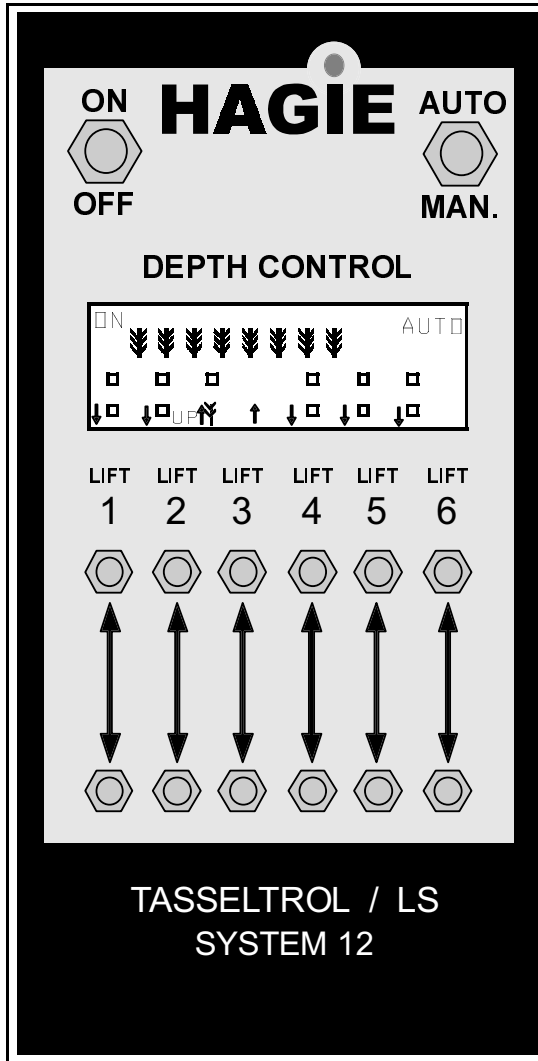

FIG 3.4

To use the control box with its normal parameter setting, use the following procedures. To adjust the given parameters, see pages 13-15.

1. From the operator's seat, turn the ignition to the "ON" position.
2. Turn the control box power switch to the "ON" position.
3. Turn the "AUTO/MANUAL" switch to "MANUAL." At this time the display will read "MANUAL" in addition to other information identifying the control box.
4. Press the individual row switches for up and down movement. An arrow in the display will indicate direction of each lift assembly. "P" indicates pressure - "UP" only.
5. If the "AUTO/MANUAL" switch is left in the "AUTO" position when the unit is first started, the display will tell you to select "MANUAL." After you have selected "MANUAL" switch back to the "AUTO" position.
6. To raise and hold one or more units during operation, press the desired "UP" switch, select "MANUAL" and back to "AUTO." This will hold the unit up in position. To re-activate the lift, switch to "MANUAL" and back to "AUTO."
7. To override the system, press the desired "UP" switch to raise the attachment. When the switch is released, the system will go back into the "AUTO" mode.
8. If the ignition is left on and the "AUTO/MANUAL" switch is left in the "AUTO" position, the down coils on the electro-hydraulic valve will lose power after 45 seconds. To re-activate, move the "AUTO/MANUAL" switch from "AUTO" to "MANUAL" and back to "AUTO."
9. The control box is set up with a feature so that if a unit loses contact during operation in the "AUTO" mode, the unit will automatically rise. If this should happen, switch to the "MANUAL" mode and determine the cause for malfunction.

### III. OPERATING INFORMATION



FIG 3.5

#### “ALL UP” and “ALL HOLD”

This function can be used to raise or lower all row units at the same time. The switches to control this option are located on the hydrostat control handle (fig. 3.5). All the row units will move up when the switch is pressed upward and will lower when the switch is pressed downward.

The parameters for dwell on the up move can be set to 0, 5, 10, 15, 20, or 25 seconds. The heads will move up in this amount of time without having to hold the switch up. All heads will hold this position when the parameter is reached. To resume automatic depth control, press the switch down.

To program the “ALL UP” and “ALL HOLD” function:

1. Put the “AUTO/MANUAL” switch to “AUTO.”
2. Put the “ON/OFF” switch to “ON.”
3. Press the “UP” button under “PAR”.
4. Press the “UP” button under “D” to set the dwell time.
5. After selecting one of the dwell time choices, press any of the down switches.
6. To escape the parameter mode, press down a second time to return to the original screen. To save the information switch the “AUTO/MANUAL” toggle to “MANUAL”.

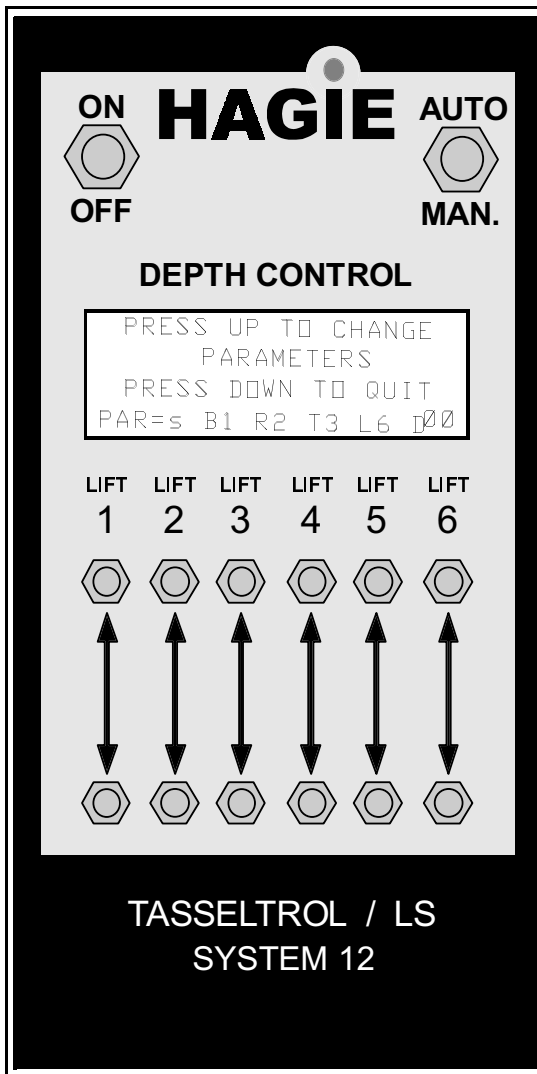

FIG 3.6

# III. OPERATING INFORMATION

## TASSELTROL® RESPONSE PARAMETER

The response parameter is used to adjust the response time of both photocells. How quickly the down motion starts when no corn is detected by either the top or bottom cells, and how quickly the up motion is stopped when corn is no longer detected by the top cell, can be changed by selecting R1, R2, R3, or R4. More corrections will occur with R1 selected, and fewer corrections with R4 selected. The normal or default value for this parameter is R2, but can be set to any desired value.

Use the response parameter to adjust overall correction activity and to compensate for ground speed. If the pullers are moving too quickly and frequently, the response parameter can be increased toward R4. If the pullers are too slow to respond to changes in the corn depth, increase the parameters toward R1. Generally this parameter can be left at R2.

To display the response parameter, select "AUTO" and turn the control box power on. Wait three seconds for the "SELECT MANUAL" message, press the "UP" button under "PAR". Now press the "UP" button under the "R" value.

The active value of the parameter is indicated by it blinking on and off, while the other three choices are displayed continuously.

To select a new value for the parameter, press the "UP" button under the desired choice.

After selecting one of the four choices, press any of the "DOWN" buttons to escape this parameter.

To save new values and escape the parameter mode, press "DOWN" a second time and switch "AUTO/MANUAL" toggle to "MANUAL."

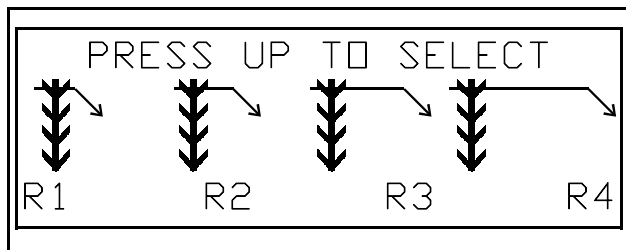
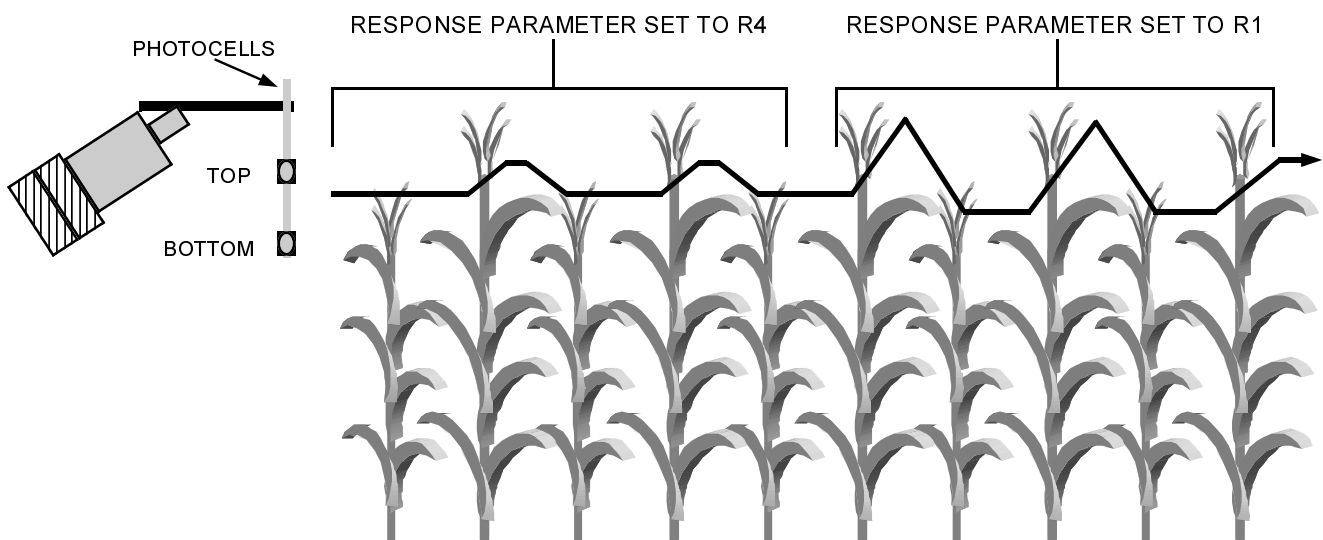

FIG 3.7

**NOTE:**  
See page 17 for more information regarding the LS photolights.





# III. OPERATING INFORMATION

## TASSELTROL® TOP PARAMETER

The top parameter is used to adjust the sensitivity of the top photocell. The top photocell starts the up motion when its lights path is blocked by corn. How much corn it has to see before starting the up move can be changed by selecting one of the four values T1, T2, T3, or T4. With T1 selected, more corn is required to start an up move. The normal or default value for this parameter is T3, but can be set to any desired value.

If the pullers move up too easily when a taller stalk of corn passes, increase the parameter toward T4. If the pullers stay deep too long when taller corn passes, decrease the parameter toward T1. Generally this parameter can be left at T3.

To display the top parameter, select "AUTO" and turn the control box power on. Wait three sec-

onds for the "SELECT MANUAL" message. Press the "UP" button under "PAR". Now press the "UP" button under the "T" value.

The active value of the parameter is indicated by it blinking on and off, while the other three choices are displayed continuously.

To select a new value for the parameter, press the "UP" button under the desired choice.

After selecting one of the four choices, press any of the "DOWN" buttons to escape this parameter.

To save new values and escape the parameter mode, press "DOWN" a second time and switch "AUTO/MANUAL" toggle to "MANUAL."

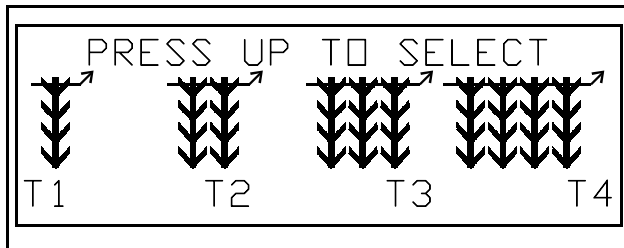
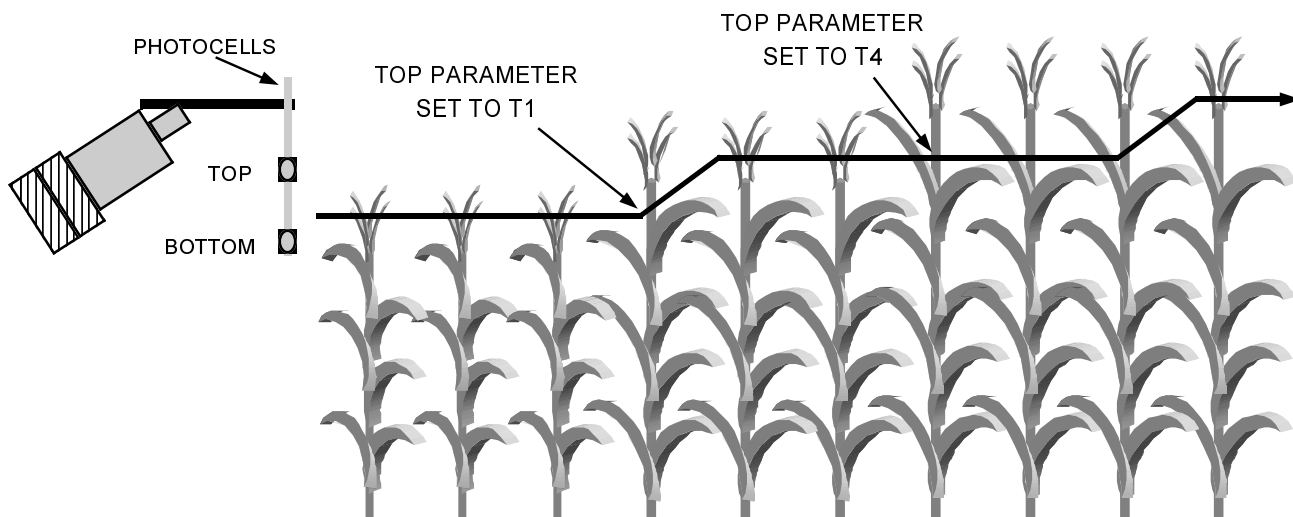

FIG 3.8

**NOTE:**  
See page 17 for more information regarding the LS photolights.



# III. OPERATING INFORMATION

## TASSELTROL® BOTTOM PARAMETER

The bottom parameter is used to adjust the sensitivity of the bottom photocell. The bottom photocell stops the down motion when its light is blocked by corn. How much corn it has to see before stopping the down move can be changed by selecting one of the four values B1, B2, B3, or B4. With B1 selected the down move will stop as soon as corn is detected. With B4 selected the down move will continue a little longer. The normal or default value for this parameter is B1, but can be set to any desired value.

If the pullers run too shallow after moving down into shorter corn, increase the parameter toward T4. If the pullers move too deep when going into shorter corn or oscillate between the top and bot-

tom photocells, decrease the parameter toward B1. Generally this parameter can be left at B1.

To display the bottom parameter, select "AUTO" and turn the control box power on. Wait three seconds for the "SELECT MANUAL" message. Press the "UP" button under "PAR". Now press the "UP" button under the "B" value.

The active value of the parameter is indicated by it blinking on and off, while the other three choices are displayed continuously.

To select a new value for the parameter, press the "UP" button under the desired choice.

After selecting one of the four choices, press any of the "DOWN" buttons to escape this parameter.

To save new values and escape the parameter mode, press "DOWN" a second time and switch "AUTO/MANUAL" toggle to "MANUAL."

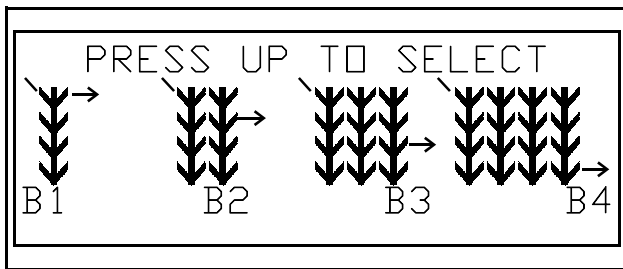
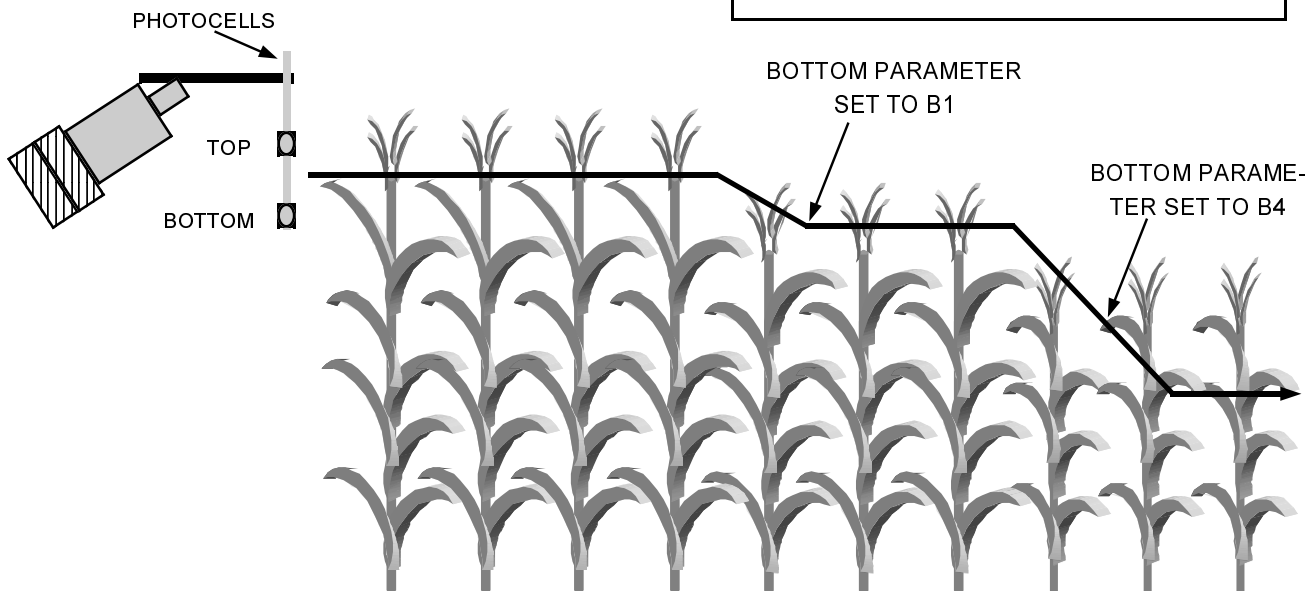

FIG 3.9

**NOTE:**  
See page 17 for more information regarding the LS photolights.





# III. OPERATING INFORMATION

## LS PHOTOLIGHT INDICATORS

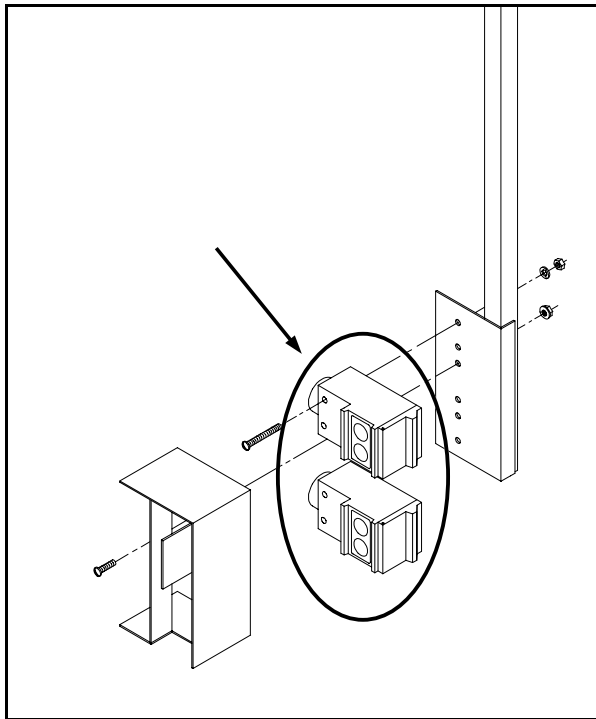

FIG 3.10

The upper and lower LS photolights (fig. 3.10) have L.E.D. lights (fig. 3.11) that indicate their operational status.

**LT/DK SWITCH** – Light/Dark switch on photolight (fig. 3.11, item 1) changes the activated condition of green L.E.D. (see below) from *ON* (“LT”) to *OFF* (“DK”). Switch does not affect the functional operation of the light, only how it is displayed. Switch should be set to “LT”.

**SENSITIVITY ADJUSTMENT SCREW** – Sensitivity adjustment screw (fig. 3.11, item 2) should always be set to maximum.

**YELLOW L.E.D.** – Yellow L.E.D. (fig. 3.11, item 3) indicates power on.

**GREEN L.E.D.** – Green L.E.D. (fig. 3.11, item 4) indicates output energized (sending a signal to Tassel-tron<sup>®</sup> box, opening the raise or lower stack valve).

**RED L.E.D.** – Red L.E.D. (fig. 3.11, item 5) indicates photolight is receiving reflected signal.

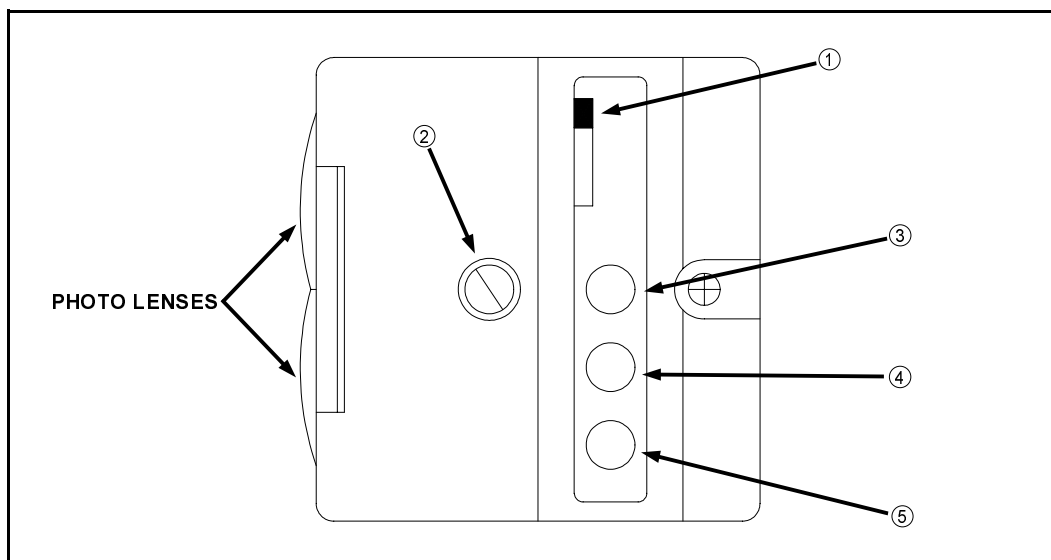

FIG 3.11

# III. OPERATING INFORMATION

## DEPTH COMMAND

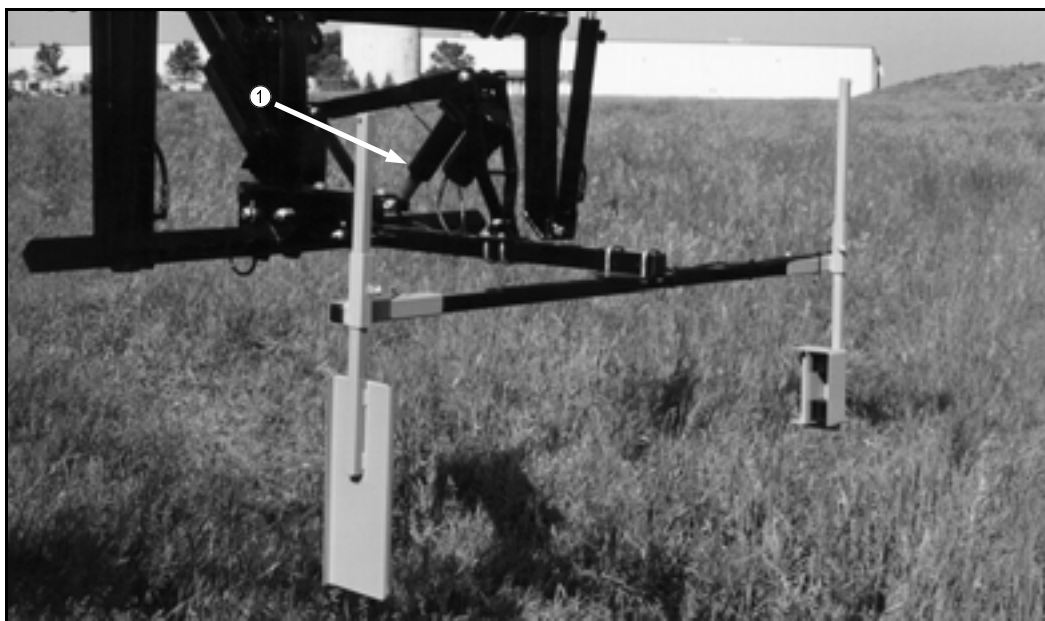

FIG 3.12



FIG 3.13

The Hagie STS 12 sprayer/detasseler combo comes available with optional adjustable DEPTH COMMAND (fig. 3.12). This allows the operator to adjust the depth of the LS system from the cab (fig. 3.13).

To lower the cutting or pulling height, select the appropriate switch and push down. This will extend the actuator (fig. 3.12, item 1), raising the LS system, which in turn lowers the cutting or pulling height. To raise the cutting height, lower the actuator by pushing the appropriate switch up.

**NOTE:**

DO NOT operate more than two actuators at one single time. This may blow the fuse located on the switch panel. For more information on the DEPTH COMMAND fuse, see page 21.

# IV. SERVICE AND MAINTENANCE

## FILTERS

### Return Filter

Remove and install a new 10 Micron rated return filter (fig. 5.1) at the end of the first 50 hours of use; subsequently, replace the filter every 250 hours, or once a year, whichever comes first.

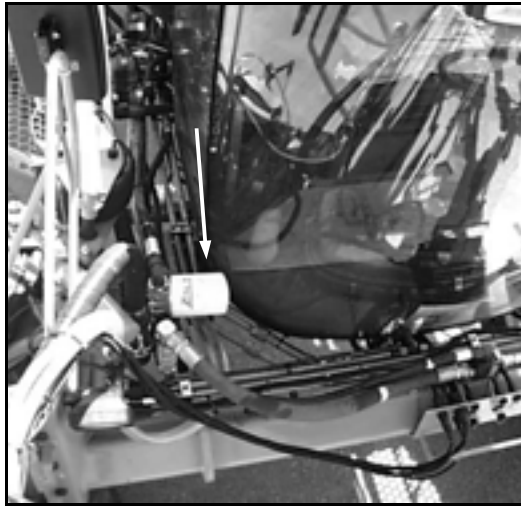

FIG 4.1

### High Pressure In-line Filter

**OUTRIGGER FOLD VALVES** - The valves on the outrigger fold valve are protected by a 90 Micron in-line sintered bronze filter (fig. 4.2).

**LIFTARM STACK VALVES** - The valves on the lift control stack valve are protected by a 90 Micron in-line sintered bronze filter (fig. 4.3).

When the filter elements are removed for cleaning, caution should be taken so the gasket is in the proper place when re-installing (fig. 4.4). Also, re-install filters paying attention to direction of flow so the ends marked "OUT" are oriented correctly.

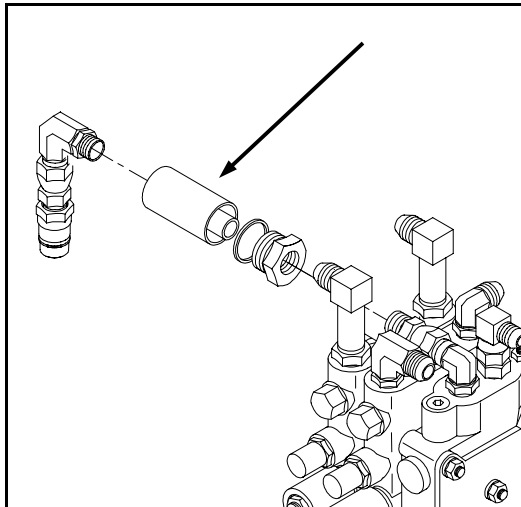

FIG 4.2

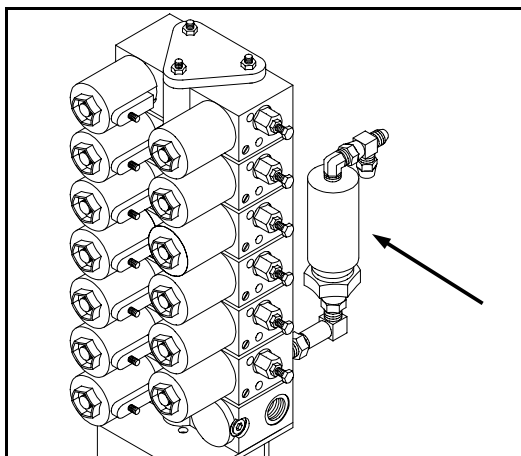

FIG 4.3

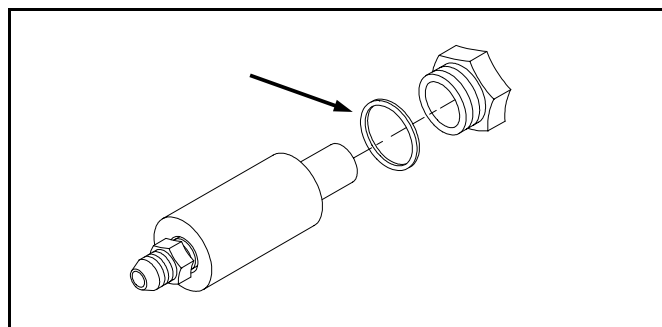

FIG 4.4

# IV. SERVICE AND MAINTENANCE

---

## LUBRICATION

### Quad Pullers

Each quad puller head has four bearings equipped with grease zerks (fig. 4.5). To ensure the longest life and best performance, grease each bearing twice a day: suggested times are morning and noon.

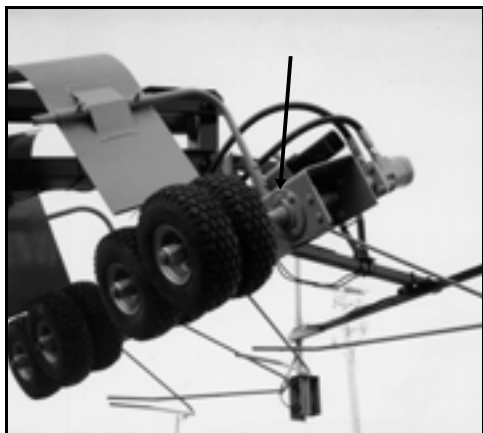

FIG 4.5

### Male Row Choppers

Each male row chopper has two bearings equipped with grease zerks (fig. 4.6). Grease each bearing once a day.

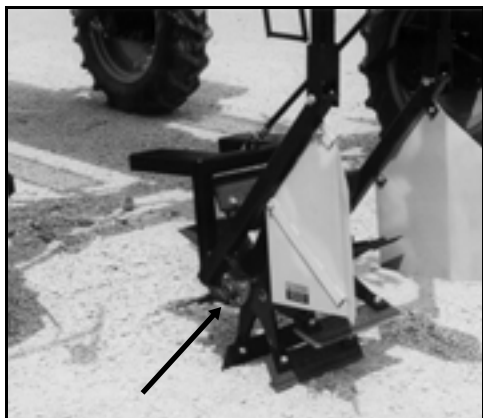

FIG 4.6

### Four Blade Male Row Cutters

Grease both upper (fig. 4.7, item 1) and lower (fig. 4.7, item 2) shaft bearings 4 times a day. Suggested times are morning, mid-morning, noon, and mid-afternoon.

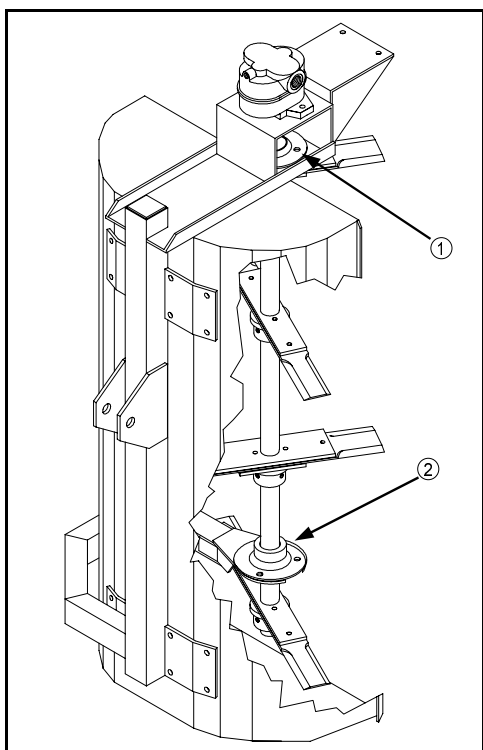

FIG 4.7

# IV. SERVICE AND MAINTENANCE

## Electrical System



FIG 4.8

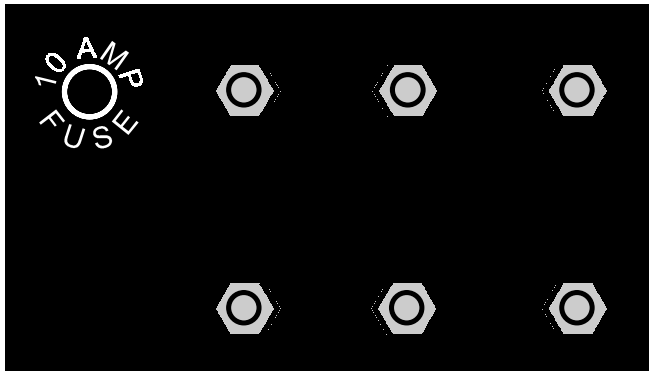

FIG 4.9

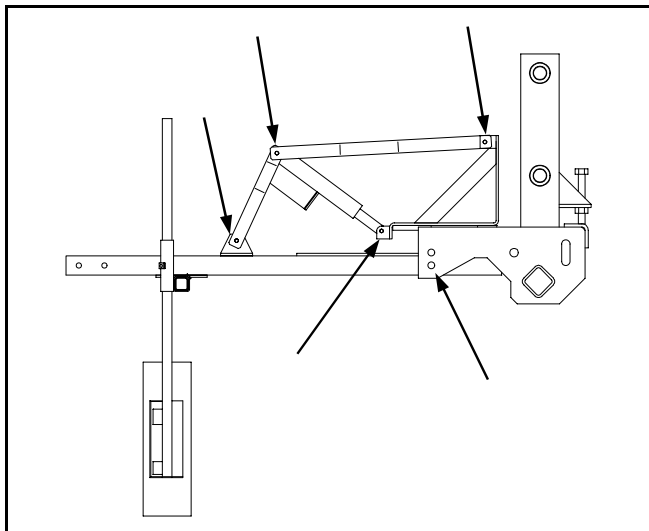

FIG 4.10

**MOTOR CONTROL FUSE** – The fuse for the DEPTH COMMAND is located in the switch box (fig. 4.8). If the DEPTH COMMAND fuse blows, remove it by rotating the fuse cap counter-clockwise as you push in. Then pull the fuse straight out. Replace the blown fuse with the same amperage fuse only (fig. 4.9). If the fuse continues to blow, determine the cause and correct it.

Operating more than two actuators at one time may cause the fuse to blow (see page 18). A blown fuse may indicate that the LS/DEPTH COMMAND pivot bolts (fig. 4.10) are torqued too tight. If the fuse continues to blow, determine cause and correct it.

SAFETY/DECALS

PREPARING TO OPERATE

OPERATING INFORMATION

SERVICE/ MAINTENANCE

TROUBLE SHOOTING

LIMITED WARRANTY

INDEX



# V. TROUBLE SHOOTING

## A. HYDRAULIC SYSTEM



### CAUTION

**DO NOT GO NEAR LEAKS.** High pressure oil easily punctures skin causing injury, gangrene, or death. If injured, seek emergency medical help. Immediate surgery is required to remove oil. Do not use finger or skin to check for leaks. Lower load or relieve hydraulic pressure before loosening fittings.

PROBLEM	POSSIBLE CAUSE	SUGGESTED REMEDY
Lifting mechanism won't lift	Bad Cylinder Blown relief valve Relief valve set too low Lift arms frozen Faulty electro-hydraulic valve	Check cylinder; remove and rebuild or replace Remove, check; replace w/ new Reset to 2000 PSI Loosen mounting bolts; lubricate grease fittings if equipped See Tasselrol®/LS and/or Tasselrol trouble shooting guide
Cutter head blades, quad pullers, rollers, or tires won't turn	Oil level in reservoir low Oil not reaching pump Faulty hydraulic pump Faulty hydraulic motor or motors	Fill reservoir to proper level with approved oil Remove suction hose from pump, check for proper flow. Reinstall hose; all suction fittings Replace hydraulic pump Replace motor or motors
Hydraulic motor leaking	Seal failure Restricted case drain hose	Replace seal; turn heads on with low engine RPM Inspect or replace hose

# V. TROUBLE SHOOTING

## B. TASSELTROL®/LS SYSTEM – HYDRAULIC



### CAUTION

DO NOT GO NEAR LEAKS. High pressure oil easily punctures skin causing injury, gangrene, or death. If injured, seek emergency medical help. Immediate surgery is required to remove oil. Do not use finger or skin to check for leaks. Lower load or relieve hydraulic pressure before loosening fittings.

PROBLEM	POSSIBLE CAUSE	SUGGESTED REMEDY
No units will lift	Oil level in reservoir low Faulty valve Relief valve in electro-hydraulic valve set too low	Fill tank to proper level Repair or replace valve Reset to 2000 PSI
No units will lower	All lift arm pivots too tight	Lubricate and loosen pivot points
Only one unit will not lower	Faulty valve Lift arm pivot too tight	Replace valve Lubricate and loosen pivot point

- SAFETY/DECALS
- PREPARING TO OPERATE
- OPERATING INFORMATION
- SERVICE/ MAINTENANCE
- TROUBLE SHOOTING**
- LIMITED WARRANTY
- INDEX

# V. TROUBLE SHOOTING

## ➔ TASSELTROL®/LS SYSTEM – HYDRAULIC CONTINUED

PROBLEM	POSSIBLE CAUSE	SUGGESTED REMEDY
All units lift slowly	<p>Hydraulic oil not at operating temperature</p> <p>Faulty valve</p> <p>Lift arm pivots too tight</p> <p>Plugged high pressure filter</p> <p>Raise orifice in valve adjusted incorrectly</p> <p>Relief valve in electro-hydraulic valve set too low</p>	<p>Allow time for oil to warm up</p> <p>Replace valve</p> <p>Lubricate and loosen pivot point</p> <p>Remove, clean, replace (see page 19)</p> <p>Contact Hagie Customer Support</p> <p>Reset to 2000 PSI</p>
Only one unit lifts slowly	<p>Faulty valve</p> <p>Lift arm pivots too tight</p> <p>Raise orifice in valve adjusted incorrectly</p>	<p>Replace valve</p> <p>Lubricate and loosen pivot point</p> <p>Contact Hagie Customer Support</p>
Only one unit will not hold position	<p>Oil leak between valve and cylinder</p> <p>Faulty valve</p> <p>Faulty lower poppet on stack valve</p>	<p>Repair leak or replace hose</p> <p>Replace valve</p> <p>Remove, clean, replace</p>
No units will hold position	Problem is not hydraulic	See Tasselrol® – elect. section

# V. TROUBLE SHOOTING

PROBLEM	POSSIBLE CAUSE	SUGGESTED REMEDY
Only one unit lowers slowly	Faulty valve	Replace valve
	Faulty lower poppet on stack valve	Remove, clean, replace
	Lower orifice incorrectly adjusted	Contact Hagie Customer Support
All units lower slowly	Hydraulic oil not at operating temperature	Allow time for oil to warm up
In "Manual" mode, more than one unit lifts or lowers from one up/down switch	Faulty valve	Replace valve
In "Auto" mode, more than one unit raises from photo sensor	Faulty valve	Replace valve
In "Auto" mode, wrong unit raises from photo sensor	Cylinder hoses are connected to wrong cylinder	Attach correct hose to proper cylinder

- SAFETY/DECALS
- PREPARING TO OPERATE
- OPERATING INFORMATION
- SERVICE/ MAINTENANCE
- TROUBLE SHOOTING**
- LIMITED WARRANTY
- INDEX

# V. TROUBLE SHOOTING

## C. TASSELTROL® / LS SYSTEM – ELECTRICAL

**NOTE:**  
Disconnect battery when servicing any part of electrical system to prevent system damage.

PROBLEM	POSSIBLE CAUSE	SUGGESTED REMEDY
No units will lift	Faulty "AUTO/MANUAL" switch  Blown fuse  Faulty #1 valve, coil, or loose coil mounting nut  Loose wire connections  Faulty wire connections  Faulty main wire assembly	Replace control box  Find short in wire, repair and replace fuse  Tighten nut or replace coil  Find loose connections, tighten  Replace or repair  Replace or repair
Only one unit will not lift	In "MANUAL" mode: faulty "UP/DOWN" switch  Light photo sensor assembly  Faulty valve, coil, or loose coil mounting unit  Loose wire connections  Lights photo sensor not lined up with reflector  Faulty row wire assembly  Faulty sensor connector wire assembly	Replace control box  Replace photo sensor  Tighten nut or replace coil  Find loose connections, tighten  Line up sensor with reflector  Replace or repair  Replace or repair

# V. TROUBLE SHOOTING

PROBLEM	POSSIBLE CAUSE	SUGGESTED REMEDY
No units will lower	<p>Faulty "AUTO/MANUAL" switch</p> <p>Blown fuse</p> <p>Loose wire connections</p> <p>In "AUTO" mode: LS valve assembly unplugged</p>	<p>Replace control box</p> <p>Find short in wire, repair and replace fuse</p> <p>Find loose connections, tighten</p> <p>Plug in wire assembly</p>
Only one unit will not lower	<p>Faulty "UP/DOWN" switch</p> <p>In "AUTO" mode: faulty light sensor assembly</p> <p>Loose wire connections</p> <p>Faulty valve coil or loose coil mounting unit</p> <p>Faulty sensor connector wire assembly</p> <p>In "AUTO" mode: light sensor not lined up with reflector</p> <p>Faulty row LS wire assembly</p>	<p>Replace control box</p> <p>Replace sensor</p> <p>Find loose connections, tighten</p> <p>Tighten nut or replace coil</p> <p>Replace or repair</p> <p>Line up sensor with reflector</p> <p>Replace or repair</p>
No units will hold position	In "AUTO" mode: no crop moving under sensor assemblies	Drive forward or select "MANUAL" mode
In "AUTO" mode, wrong unit raises from sensor assembly	Row LS wire assembly plugged into wrong sensor connector	Plug correct wire assembly into proper row sensor connector assembly

SAFETY/DECALS
PREPARING TO OPERATE
OPERATING INFORMATION
SERVICE/ MAINTENANCE
<b>TROUBLE SHOOTING</b>
LIMITED WARRANTY
INDEX

# V. TROUBLE SHOOTING

## ➔ TASSELTROL®/LS SYSTEM – ELECTRICAL CONTINUED

### TASSELTROL® DISPLAY TROUBLESHOOTING

To gain further information on the status of the Tasselrol®/LS system before operation: while sitting in the operator's seat, turn the ignition key to the "ON" position (do not start the engine); turn the Tasselrol® box to the "ON" position; turn the "AUTO/MANUAL" switch to "MANUAL."

Make sure there is nothing physically blocking any upper or lower sensor's path to its reflector.

The display will show the status of the upper and lower photo sensor on each lift assembly. If the display shows a box ("□") in all upper and lower areas, the unit is ready for operation. If the display shows a corn stalk ("☿") in one or more areas, refer to pages 26-27 for further suggested remedies.

The LEFT-CENTER sensors are used as examples.

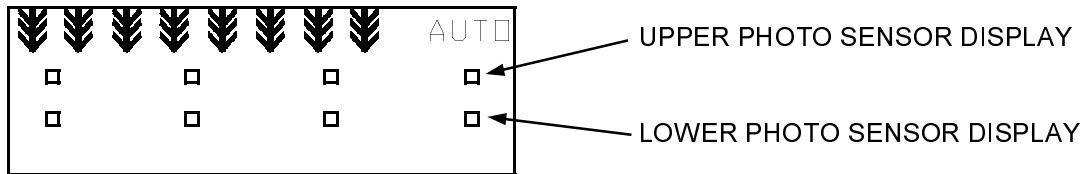

### TASSELTROL® DISPLAY

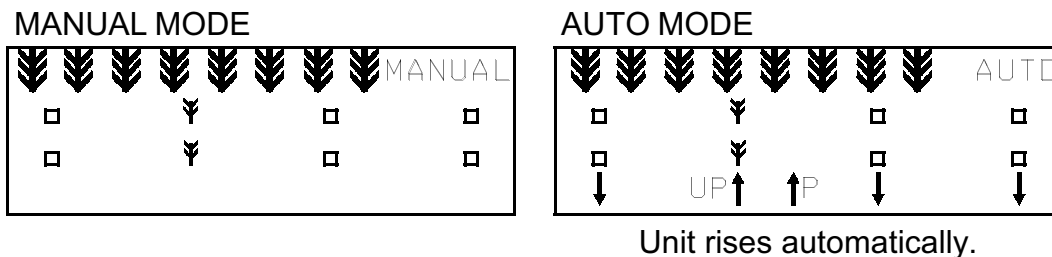
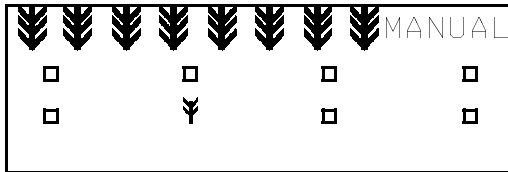

PHOTO SENSOR STATUS LIGHTS	POSSIBLE CAUSE
Lights at both photo sensors	Photo sensors not in line with reflector
No lights at either photo sensor	Faulty connector cable (See page 31, fig. 5.1, item 2)  Faulty RED and/or BLACK wire in connector cable (See page 31, fig. 5.1, item 1)

# V. TROUBLE SHOOTING

## TASSELTROL® DISPLAY

MANUAL MODE



AUTO MODE

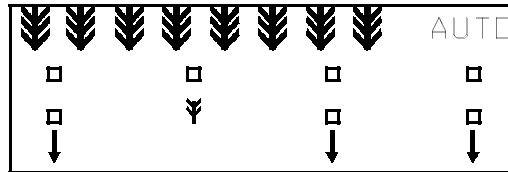

Unit does NOT rise automatically.

PHOTO SENSOR STATUS LIGHTS	POSSIBLE CAUSE
Lights at lower photo sensor	<p>Faulty GREEN wire in connector cable (See page 31, fig. 5.1, item 2)</p> <p>Photo sensor not in line with reflector</p> <p>Faulty BLUE wire in sensor assembly (See page 31, fig. 5.1, item 1)</p>
No lights at lower photo sensor	<p>Faulty RED and/or BLACK wire in connector cable (See page 31, fig. 5.1, item 2)</p>

SAFETY/DECALS

PREPARING TO OPERATE

OPERATING INFORMATION

SERVICE/ MAINTENANCE

TROUBLE SHOOTING

LIMITED WARRANTY

INDEX



# V. TROUBLE SHOOTING

## ➔ TASSELTROL®/LS SYSTEM – ELECTRICAL CONTINUED

### TASSELTROL® DISPLAY

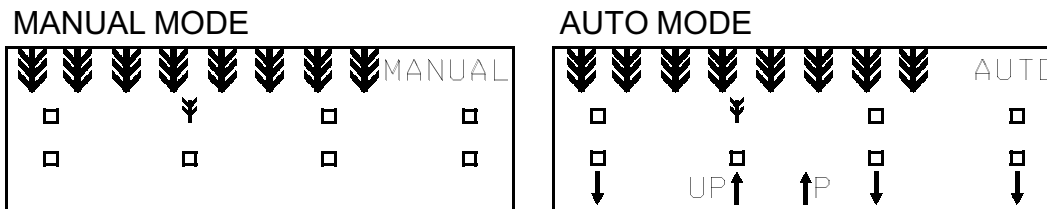

Unit rises automatically.

PHOTO SENSOR STATUS LIGHTS	POSSIBLE CAUSE
Lights at upper photo sensor	Faulty WHITE wire in sensor assembly (See page 31, fig. 5.1, item 1)  Faulty BLUE wire in sensor assembly (See page 31, fig. 5.1, item 1)
No lights at upper photo sensor	Faulty RED and/or BLACK wire in connector cable (See page 31, fig. 5.1, item 2)

# V. TROUBLE SHOOTING

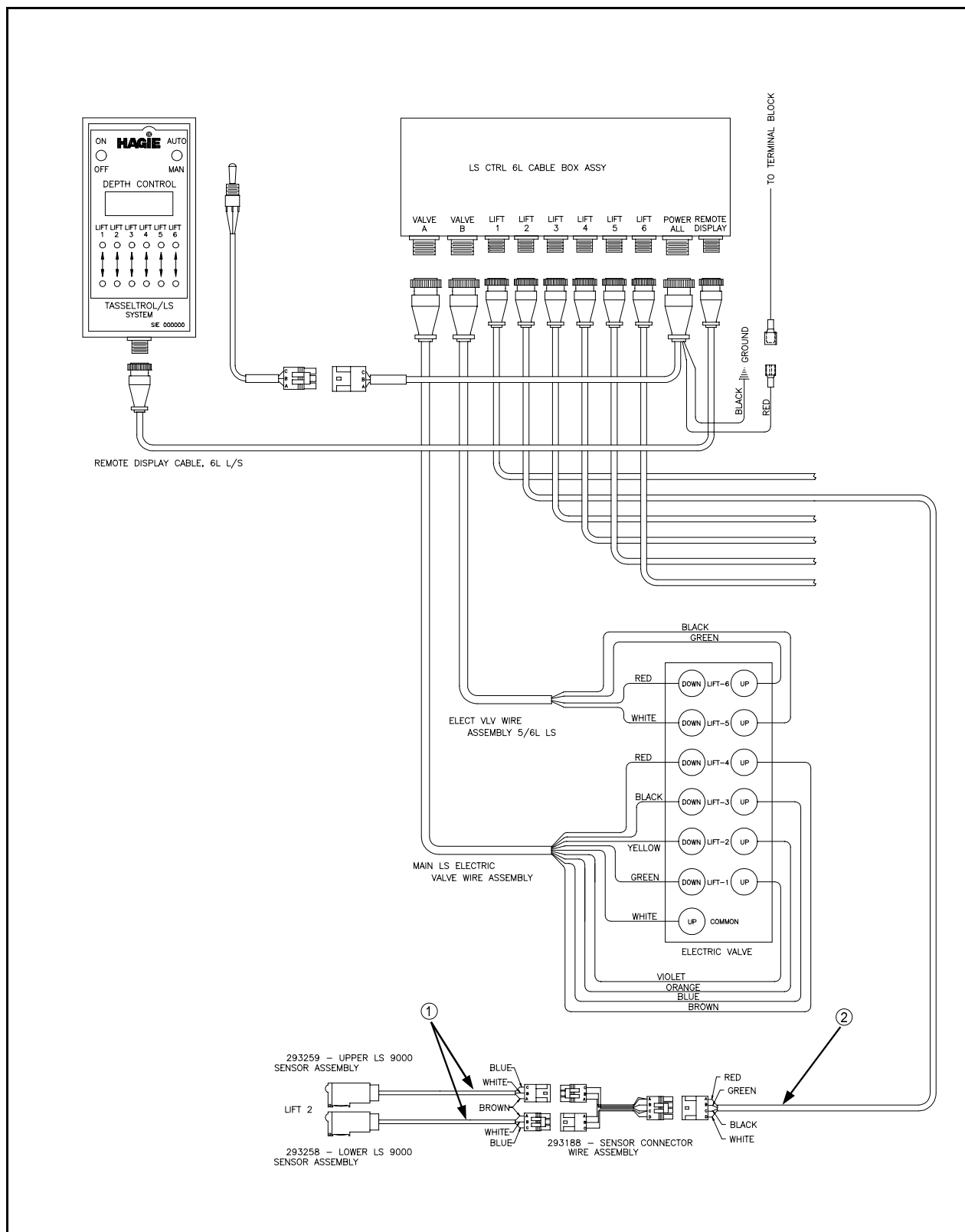

FIG 5.1

- SAFETY/DECALS
- PREPARING TO OPERATE
- OPERATING INFORMATION
- SERVICE/ MAINTENANCE
- TRUBLE SHOOTING**
- LIMITED WARRANTY
- INDEX

## V. TROUBLE SHOOTING

---

NOTES

# VI. LIMITED WARRANTY

## 1. The Warranty

- a. This warranty gives you specific legal rights. You may also have other rights which may vary from state to state.
- b. Hagie makes this warranty only to the original purchaser of its new equipment.
- c. The warranty period ends 12 months from the date of delivery of equipment to the original purchaser. When requesting warranty service, the original purchaser must present evidence of the date of delivery of the equipment.
- d. Parts or rebuilt assemblies furnished under the terms of this warranty are not warranted beyond the original warranty period.
- e. Exceptions to this warranty must be covered by separate warranty agreements.

## 2. Items not covered by Hagie Warranty

- a. Used equipment.
- b. Tires, tubes, engines, and batteries (under separate manufacturer's warranty).
- c. Depreciation or damage caused by normal wear, accident, improper maintenance, improper storage, or improper use.
- d. Service calls and transporting the equipment to and from the place where the warranty work is performed.

## 3. Unapproved service or modification

### NOTE:

All obligations of Hagie Manufacturing Company under this warranty shall be terminated if:

- a. . . . service is performed by someone other than Hagie authorized personnel.  
or
- b. . . . the equipment is modified or altered without Hagie approval.

## 4. No commercial loss coverage

- a. Hagie shall not be liable for incidental or consequential damages or injuries (damage and repairs of equipment itself, loss of profits, rental or substitute equipment, loss of good will, etc.).
- b. SOME STATES DO NOT ALLOW THE EXCLUSION OR LIMITATION OF INCIDENTAL OR CONSEQUENTIAL DAMAGES, SO THE ABOVE LIMITATION MAY NOT APPLY TO YOU.

## 5. Merger clause

- a. The entire warranty agreement is included in this writing.
- b. Any oral agreements that are made by the selling persons about the equipment are not warranties, and are not to be relied upon by the purchaser.

## 6. No representations or implied warranty

- a. The parties agree that the implied warranties of merchantability and fitness for a particular purpose and all other warranties expressed or implied, are excluded from this transaction and shall not apply to the equipment sold.

# INDEX

	PAGE		PAGE
<b>A</b>			
<b>Adjusting</b>		<b>Male Corn Cutters</b>	
Detasseling Depth .....	18	Four-Blade (Lubrication) .....	20
<b>B</b>			
<b>Bottom Parameter, Tasselrol®</b> .....	15	<b>O</b>	
<b>C</b>			
<b>Choppers, Male Corn</b> .....	20	<b>Operating Information</b> .....	9-18
<b>Cutters</b> .....	9	<b>P</b>	
<b>D</b>			
<b>Depth Command</b>		<b>Prepare to Operate</b> .....	7-8
Fuse .....	21	<b>Programming Tasselrol®</b> .....	10-16
Operating .....	18	<b>Q</b>	
<b>Detasseling Heads</b> .....	9	<b>Quad Pullers</b>	
<b>E</b>			
<b>Electrical System</b> .....	21	Lubrication .....	20
<b>F</b>			
<b>Filters</b>		Operating .....	9
Hydraulic High-Pressure In-Line Filters .....	19	<b>R</b>	
Hydraulic Return Filter .....	19	<b>Response Parameter, Tasselrol®</b> .....	13
<b>Fuses</b> .....	21	<b>Return Filter, Hydraulic</b> .....	19
<b>H</b>			
<b>High-Pressure In-Line Filters</b> .....	19	<b>S</b>	
<b>Hydraulic Filters</b>			
High-Pressure In-Line .....	19	<b>Service/Maintenance</b> .....	19-21
Return .....	19	<b>Switches</b>	
<b>L</b>			
<b>Light Sensing (LS) System</b> .....	10-17	Depth Command .....	18
<b>Lubrication</b>			
Detasseling Heads		Hydraulic Motor Control Valve Switches .....	9
Quad Puller .....	9	<b>T</b>	
Male Corn Equipment		<b>Table of Contents</b> .....	3
Eight Blade Chopper .....	20	<b>Tasselrol®</b>	
Four Blade Male Cutter .....	20	Operating .....	11
<b>M</b>			
<b>Male Corn Choppers</b>		Programming	
Lubricating .....	20	All Up Dwell .....	12
		Bottom Parameter .....	15
		Response Parameter .....	13
		Top Parameter .....	14
		<b>Top Parameter, Tasselrol®</b> .....	14
		<b>Trouble Shooting Guide</b> .....	22-32
		<b>W</b>	
		<b>Warning Decal Location</b> .....	5-6
		<b>Warranty</b> .....	33

# NOTES

---

SAFETY/DECALS

PREPARING  
TO OPERATE

OPERATING  
INFORMATION

SERVICE/  
MAINTENANCE

TROUBLE  
SHOOTING

LIMITED  
WARRANTY

INDEX



Sample

**HAGIE**  
UpFront