



**PARTS MANUAL
FOR
HAGIE MODEL STS 14 HI-TRACTOR**

HAGIE MANUFACTURING COMPANY

721 CENTRAL AVENUE WEST
BOX 273
CLARION, IOWA 50525-0273

COVERS MACHINE SERIAL NUMBERS:U1631111001 thru U1631111100
08-10 493508
05-12, 02-16, 03-17

To obtain the most current parts manual for your machine, please visit www.hagiehelp.com.
© 2010, 2012, 2016-17 Hagie Manufacturing Company, Clarion, Iowa USA

SPRAYER IDENTIFICATION

Each Hagie sprayer is identified by means of a frame serial number. This serial number denotes the model, the year in which it was built, and the number of the sprayer. As for further identification, the engine has a serial number and the planetary hubs have identification plates that describe the type of mount and gear ratio. To insure prompt, efficient service when ordering parts or requesting service repairs from Hagie Manufacturing Company, record the serial and identification numbers in the space provided below.

NOTE: Reference to left hand and right hand used throughout this manual refers to the position when seated in the operator's seat facing forward.

SPRAYER SERIAL NUMBER

ENGINE SERIAL NUMBER

PLANETARY HUB IDENTIFICATION NUMBERS

FILTER QUICK REFERENCE

<u>QTY.</u>	<u>PART NO.</u>	<u>DESCRIPTION</u>
1	311543	ENGINE AIR FILTER, PRIMARY
1	311544	ENGINE AIR FILTER, SECONDARY
1	316281	FUEL STRAINER IN LINE
1	316372	ENGINE OIL FILTER
1	316683	FUEL FILTER
1	316684	REMOTE FUEL FILTER
1	605626	HYDRAULIC OIL FILTER
1	657463	CAB PAPER FILTER
1	657464	CAB CHARCOAL FILTER

TABLE OF CONTENTS

ENGINE ASSEMBLY 4-8

RADIATOR AND OIL COOLER ASSEMBLY. 9

AIR CLEANER AND EXHAUST ASSEMBLY. 10-11

FUEL AND OIL TANK ASSEMBLY. 12-13

BATTERY 14

TIRE ASSEMBLY 15

LEG ASSEMBLY 16-23

TREAD ADJUST ASSEMBLY 24-27

HYDRAULIC TUBING 28-29

HYDRAULIC MANIFOLDS 30-33

SOLUTION CONTROL AND QUICK COUPLER 34-35

LADDER AND BRAKE VALVE ASSEMBLY 36

LADDER ASSEMBLY 37

SERVICE PLATFORM. 38

AIR DRIER AND AIR TANK ASSEMBLY 39-41

CAB ASSEMBLY. 42-57

FLASHER AND LIGHT RELAY 58

REAR ELECTRICAL AND ENGINE BOX ASSEMBLY 59-60

BUMPER AND ENGINE HOOD. 61-63

SOLUTION TANK 64-66

SOLUTION PUMP AND ELECTRIC VALVES 67-87

REAR WHEEL NOZZLE 88

TRANSOM, BOOM, AND LIFT COMPONENTS. 89-107

FOAMER AND FRESH WATER TANK. 108-114

PRESSURE WASHER OPTION 115-117

SIDE FILL/CHEMICAL INDUCTOR OPTION 118-120

FRONT FILL OPTION 121

FENDER OPTION. 122-123

FLOW MAX 110 MONITOR. 124

BOOM STAND OPTION 125

WET BOOM OPTION. 126-141

AWS HYDRAULIC VALVE 142

AIR LINE DIAGRAM. 143

DECALS 144-145

HYDRAULIC DIAGRAM. 146-153

ELECTRICAL DIAGRAM 154-167

ABBREVIATIONS 168

INDEX 169

PARTS ORDER FORM. 173

ENGINE ASSEMBLY

DET. QTY PART NO. DESCRIPTION

DET.	QTY	PART NO.	DESCRIPTION
1	1	292544	ENG HEATR CBL ASSY,RED 6GA '10
2	1	316371	GASKET, AUX DRIVE CUMM 154916
3	1	316662	AIR INTAKE PIPE W/FLG,T3 ENG
4	1	316884	CUMM ENG,QSB6.7C,275HP,STS14
5	1	316683	FUEL FILTER, ENG, TIER 3 07
6	1	800502	PUMP DRIVE,DIRECT SAE#3/C 23T
7	1	800503	DRIVE DISK ASSY,11.5" 23T SPL
8	12	473798	10MM LOCK WASHER
9	12	473818	10MM-1.50 X 40MM HEX BOLT (H)
10	8	900128	3/8UNC X 3/4 HEX BOLT
11	8	920502	3/8 LOCK WASHER
12	2	473767	6MM-1.00 HEX NUT
13	2	473768	6MM LOCK WASHER
14	2	473799	10MM FLAT WASHER
15	2	473844	10MM-1.50 X 30 SOC HD CAP SCR
16	1	520120	HOSE CLAMP NO 4 STAINLESS
17	1	520160	CUSH CLAMP,#24 1 1/2D-3/4WLOOP
18	1	601537	HOSE, 3/4 X 24 CLEAR VINYL
19	1	601625	HOSE, 1/4 X 14 AIR
20	1	618059	7/8MJIC-3/4MNPT ADPTR
21	1	618699	1 1/16MJIC-M27X2.0MOR ADPTR
22	1	711039	1/8MNPT-90-1/4 NYL TUBE LBO
23	1	611127	1 1/16MJIC-1 1/16MOR ADPTR
24	1	618476	1 5/8MJIC-90-1 5/16MOR LBO
25	1	618762	1 5/8FJIC-1 7/8MJIC ADPTR
26	1	618763	1 1/16MJIC-90-1 1/16FJX TUBE
27	1	618641	1 1/16FJIC-1 5/16MJIC ADPTR
28	1	607001	SAUER GEAR PUMP 29CC DE1L
29	1	520101	CUSH CLAMP,#16 1"D X 1/2W
30	1	611306	12-P919J-12FJX-12FJX90-42 H/A
31	1	657485	10-213-10FJX-10FJX-62 H/A

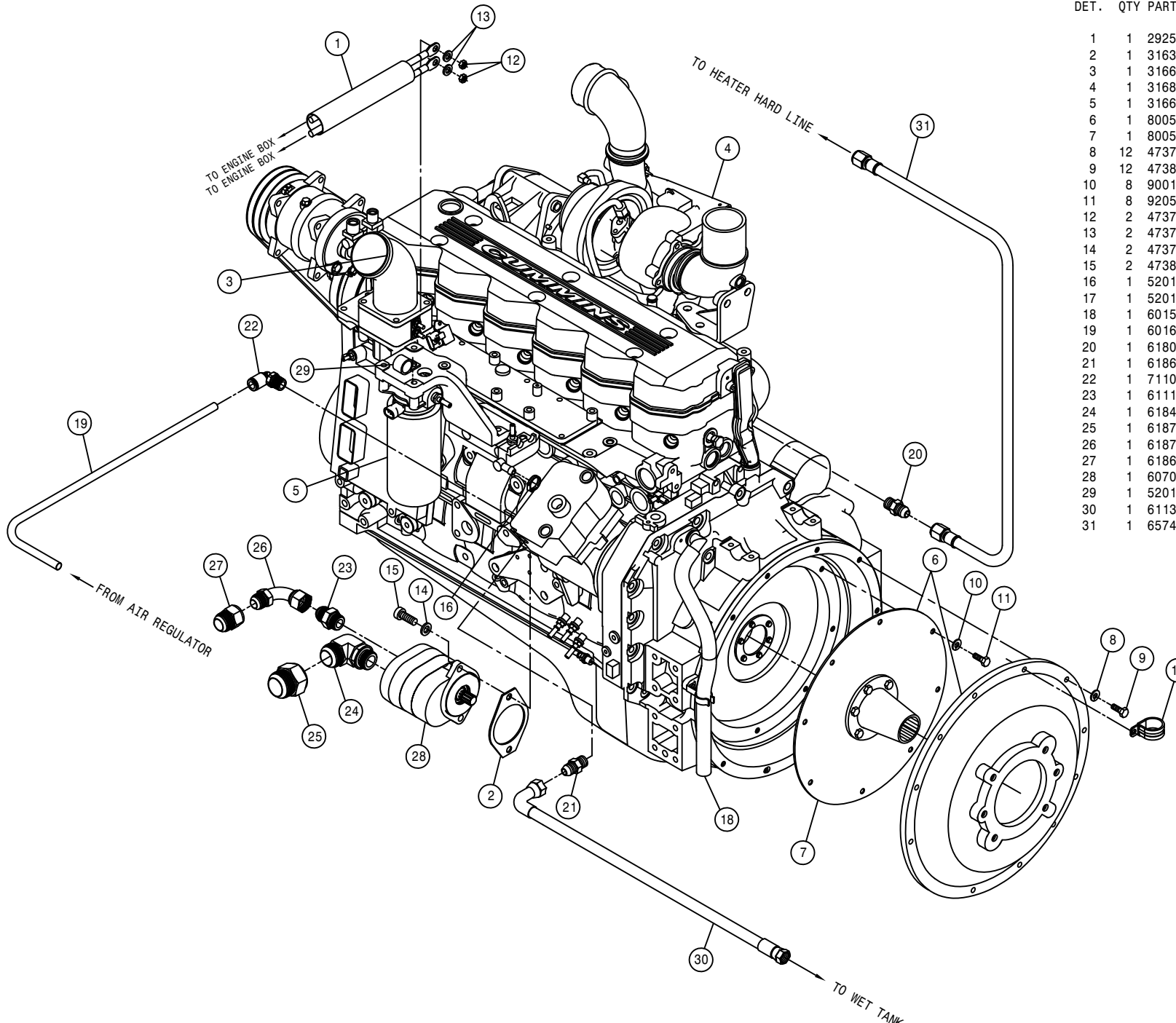

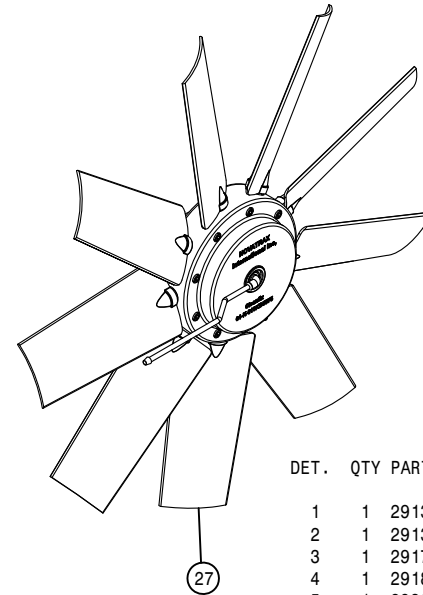
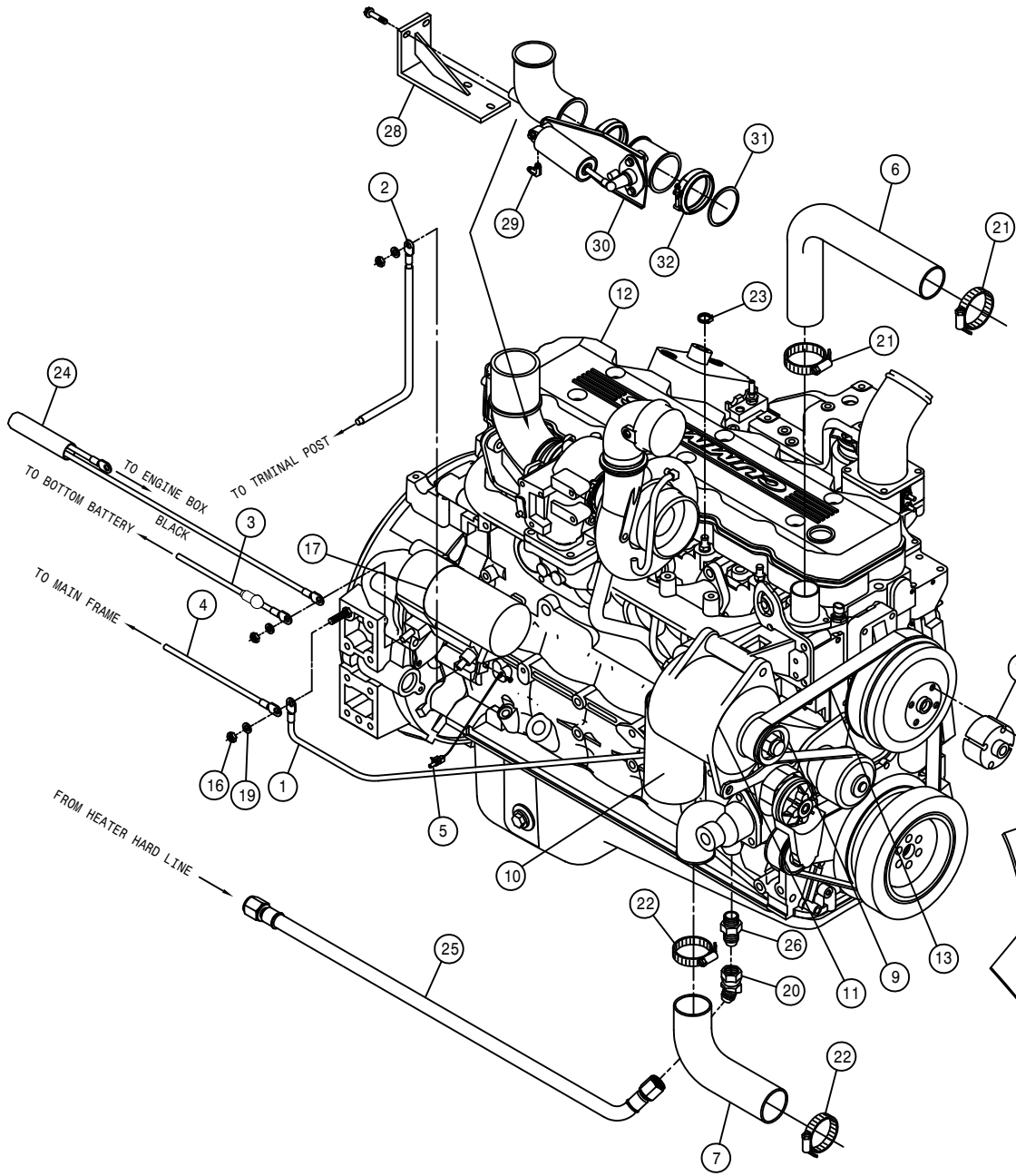

ENGINE ASSEMBLY

DET. QTY PART NO. DESCRIPTION

1	1	291358	BATT CABLE, BLK 56"2GA.281- 8mm
2	1	291359	BATT CABLE, RED 26"2/0 3/8-3/8
3	1	291708	BATT CABLE, BLK 73"2/0 3/8-3/8
4	1	291892	BATT CABLE, BLK 42"4GA.406-.406
5	1	293631	STARTER WIRE HARNESS, STS
6	1	314832	RADIATOR HOSE 1.75 X 19(52818)
7	1	314987	LWR RADIATOR HOSE STS-12
8	1	316524	FAN, 28" CUMM QSB5.9C, STS 02
9	1	316370	ALT PULLEY, 2.76 OD, 8-GROOVE
10	1	316372	LUBE FILTER (CUMM ENG 316360)
11	1	316394	DELCO ALTERNATOR, 160 AMP
12	1	316884	CUMM ENG, QSB6.7C, 275HP, STS14
13	1	316680	FAN BELT, TIER 3 ENGINE 07
14	1	316681	FAN SPACER, 6.4MM, TIER 3 ENG 07
15	1	316682	FAN SPACER, 63.5MM, TIER3 ENG 07
16	1	473778	8MM-1.25 HEX NUT
17	1	316723	STARTER, CUMM R4.0 ST9371
18	4	473780	10MM-1.50 X 90MM FLANGE BOLT
19	1	473804	8MM LOCK WASHER
20	1	618628	7/8MJIC-45-7/8FJIC SWIV LBO
21	2	520067	HOSE CLAMP NO 28 STAINLESS
22	2	520099	HOSE CLAMP NO 40 STAINLESS
23	1	520069	HOSE CLAMP NO 6 STAINLESS
24	1	292543	CAB PWR, GND CBLE ASSY STS14/16
25	1	657484	10-213-10FJX-10FJX-89 H/A
26	1	618325	7/8MJIC-1/2MNPT ADPTR
27	1	316810	REVERSING FAN KIT, STS 6.7L 07-
28	1	316801	A51303<
29	1	711058	7/16MJIC-90-1/4MNPT LBO BRS
30	1	316644	EXHAUST BRAKE, CUMMINS 05
31	1	316645	GASKET, EXHAUST BRAKE CUMMINS
32	1	316646	V-CLAMP, EXHAUST BRAKE, CUMMINS

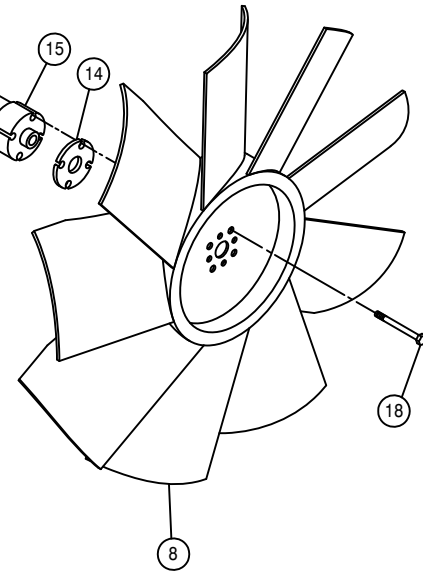

A/C COMPRESSOR PUMP ASSEMBLY

DET. QTY PART NO. DESCRIPTION

1	1	147052	BELT, 9470 GATES
2	1	316591	A/C MTG BRKT WLD, STS 2004
3	3	473844	10MM-1.50 X 30 SOC HD CAP SCR
4	3	473798	10MM LOCK WASHER
5	1	291675	PED, TERM, M, WP, 16-14GA
6	1	657450	A/C COMP SR, 90D PORT TM15/12
7	4	900131	3/8UNC X 1 1/2 HEX BOLT
8	4	910004	3/8UNC HEX NUT
9	1	657446	A/C HOSE, 08-08F90-08F90SV-65"
10	1	657447	A/C HOSE, 10-10F90-10F90SV-92"
11	1	291593	PED, RECP, WP, 1W
12	1	291620	PED, SEAL, GREEN, 18-16GA

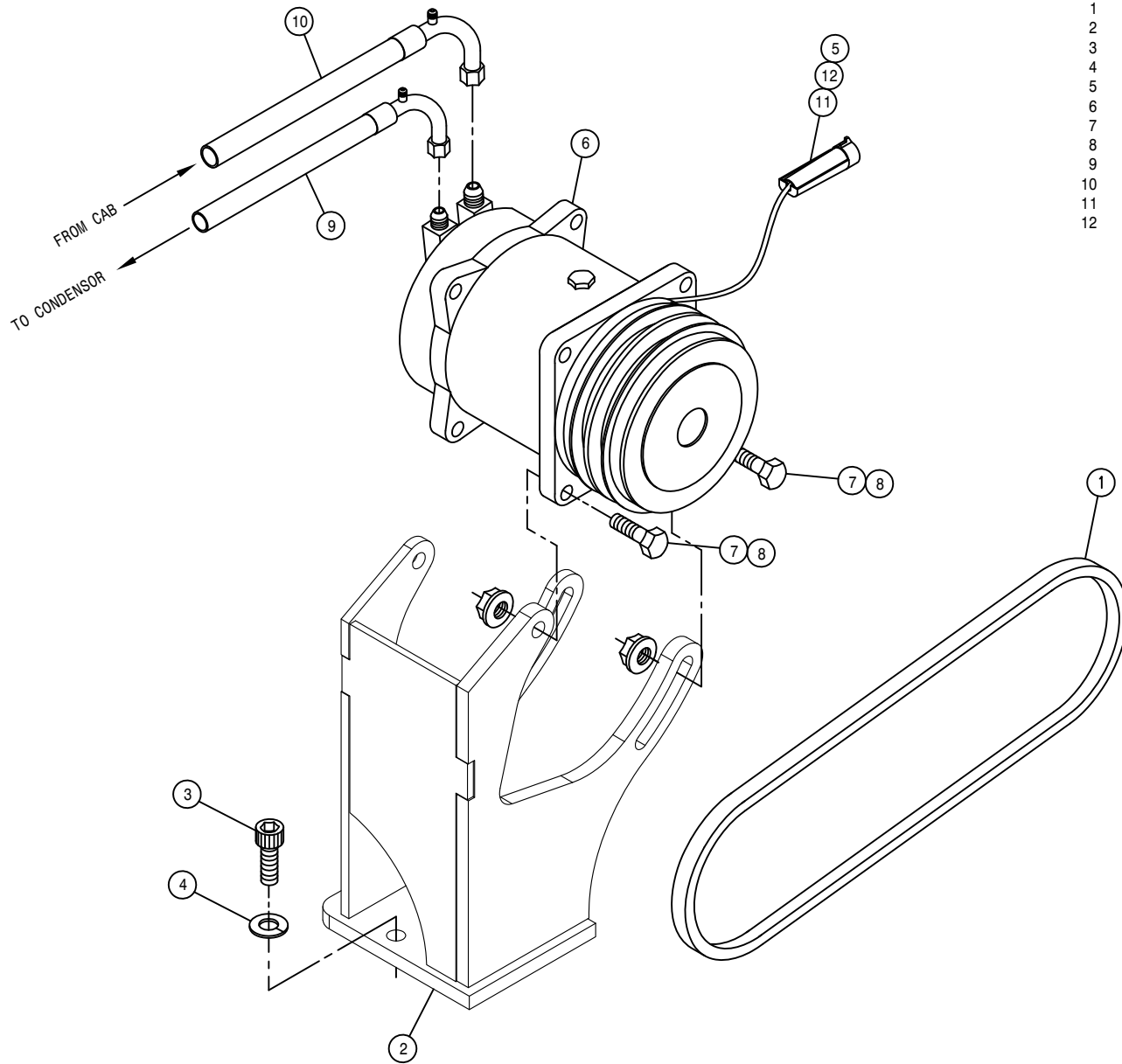

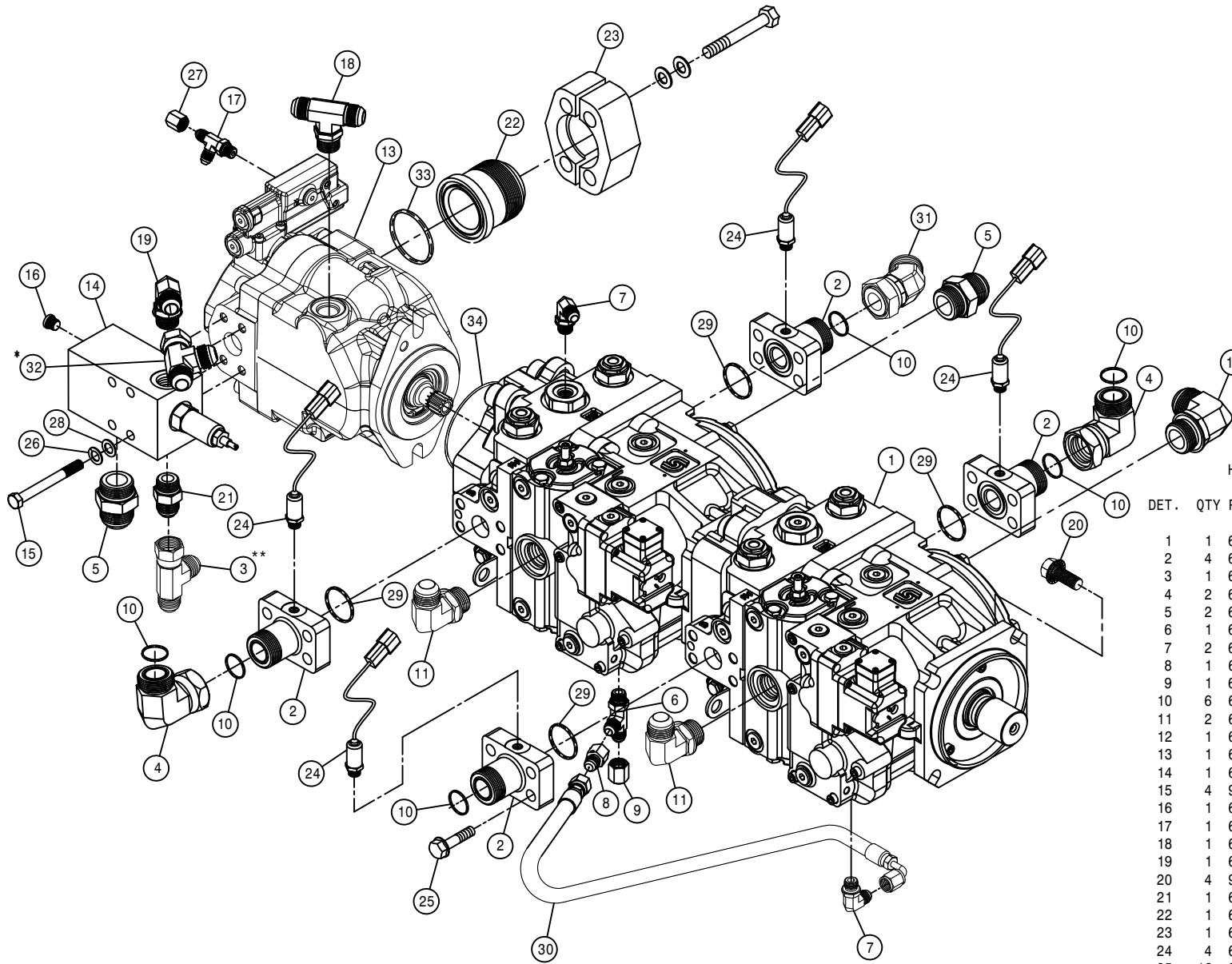

HYDROSTATIC PUMP ASSEMBLY

DET. QTY PART NO. DESCRIPTION

DET.	QTY	PART NO.	DESCRIPTION
1	1	606170	TANDEM PUMP, 606173 & 606176 05
2	4	618799	1" FLG-1" ORFS ADPTR W/9/16 PORT
3	1	618333	7/8 FJIC SW RUN TEE-7/8 MJIC
4	2	618362	1 7/16 MFOR-90-1 7/16 FFOR LBO
5	2	618186	1 5/16 MJIC-1 5/16 MOR ADPTR
6	1	618444	9/16 MOR RUN TEE-9/16 MJIC
7	2	618119	9/16 MJIC-90-9/16 MOR LBO
8	1	618734	9/16 JIC .047 ORIFICE ADPTR
9	1	618531	9/16 FJIC CAP NUT
10	6	618677	O-RING, -16 FACE SEAL .93ID 90D
11	2	618248	1 1/16 MJIC-90-1 1/16 MOR LBO
12	1	618178	1 5/16 MJIC-90-1 5/16 MOR LBO
13	1	607004	SAUER PISTON PUMP JRR060B
14	1	606258	REFIEF, LS PUMP SAUER
15	4	900138	3/8 UNC X 3 1/2 HEX BOLT
16	1	618753	7/16 MOR PLUG, HEX SOCKET
17	1	618509	7/16 MOR RUN TEE-7/16 MJIC
18	1	618637	7/8 MOR BRANCH TEE-7/8 MJIC
19	1	618183	3/4 MJIC-90-7/8 MOR LBO
20	4	900264	1/2 UNC X 1 1/4 HEX BOLT
21	1	611126	7/8 MJIC-7/8 MOR ADPTR
22	1	618765	2" FLANGE-2 1/2 MJIC ADPTR #61
23	1	618766	2" SPLIT FLANGE KIT #61
24	4	606196	PRESSURE TRANSDUCER, 9000 PSI
25	16	900198	7/16 UNC X 1 3/4 HEX BOLT
26	4	920502	3/8 LOCK WASHER
27	1	618363	7/16 FJIC CAP NUT
28	4	920002	3/8 SAE FLAT WASHER
29	4	870219	BUNA ORING 1 5/16 X 1 9/16 90D
30	1	616038	04-471TC-06FJX-06FJX90-15 H/A
31	1	618853	1 7/16 MFOR-45-1 7/16 FFOR ADPTR
32	1	618451	3/4 FJIC SW RUN TEE-3/4 MJIC
33	1	618394	O-RING FOR 2" FLANGE -32
34	1	606357	O-RING, 3.737ID-.103CS-3.94 BMT

NOTE: 1. (*) USED WITH THE TREAD ADJUST OPTION.
 2. (**) USED WITH THE PRESSURE WASHER OPTION.

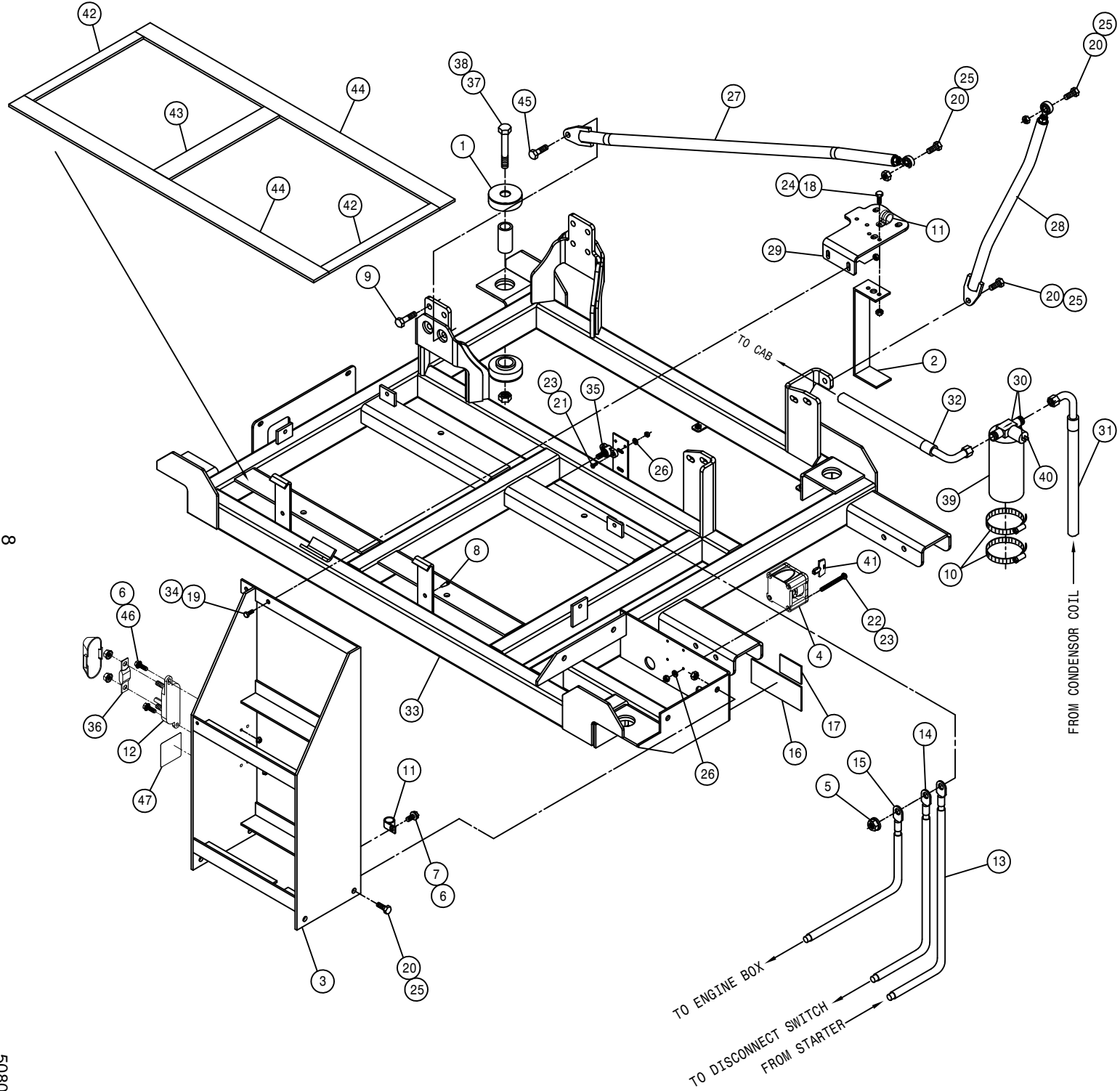

ENGINE SKID ASSEMBLY

DET.	QTY	PART NO.	DESCRIPTION
1	4	311057	RUBBER MT SET,SSB33-1000-4
2	1	316432	A/C DRIER MT
3	1	316637	BATTERY BOX WLD STS 05
4	1	291962	BATTERY SWITCH,ON/OFF(KEY)6005
5	1	910004	3/8UNC HEX NUT
6	3	470121	1/4UNC HEX FLANGE LOCK NUT
7	1	470122	1/4UNC X 1/2 FLANGE HEX BOLT
8	6	470313	GROMMET BUMPER,1/4T X 1/4D MT
9	11	473855	12MM-1.75 X 35MM FLANGE BOLT
10	2	520052	HOSE CLAMP NO 52 STAINLESS
11	2	520121	CUSH CLAMP,#16 1IN X 3/4W
12	1	292578	HIGH AMP FUSE HOLDER W/COVER
13	1	291359	BATT CABLE,RED 26*2/0 3/8-3/8
14	1	291997	BATT CABLE,RED 40*2/0 3/8-3/8
15	1	292541	BATT CABLE,RED 72*2/0 3/8-1/2
16	1	650107	DECAL,CAUTION BOOSTER STS12
17	1	650372	DECAL,MAIN ELECTRIC DISCONNECT
18	2	900065	5/16UNC X 1" HEX BOLT
19	2	900129	3/8UNC X 1" SERR FLANGE BOLT
20	7	900264	1/2UNC X 1 1/4 HEX BOLT
21	2	903706	10-32X1/2 PHIL PAN MACH SCR
22	4	903897	10-32X2 1/2 PHIL PAN MACH SCR
23	6	910027	10-32 HEX NUT
24	2	914002	5/16UNC HEX STOVER NUT
25	7	914008	1/2UNC HEX STOVER NUT
26	6	920510	#10 LOCK WASHER
27	1	316828	LH RAD BRACE ASSY,STS 10/12' 10
28	1	316730	RH RAD BRACE ASSY,STS 10/12' 07
29	1	316729	RAD MT PLT, STS T3 QSB 07
30	1	657438	RECEIVER DRIER W/SWITCH
31	1	657443	A/C HOSE,06-06F90-06F90-34"
32	1	657474	A/C HOSE,06-06F-06F90-128"
33	1	316650	SKID WLD, STS LS TIER 3 06
34	2	470087	3/8UNC HEX FLANGE LOCK NUT
35	1	291936	TERM BLOCK,RED, 3/8-16 SINGLE
36	1	291330	FUSE, 200 AMP 32 VOLT DC
37	4	900408	3/4UNC X 3 1/2 HEX BOLT
38	4	914012	3/4UNC HEX STOVER NUT
39	1	657421	A/C RECEIVER/DRIER
40	1	657422	A/C BINARY SWITCH
41	1	291963	KEY,BATTERY SWITCH 291962
42	2	470561	IND BELT, 1.00 X 15.00 .203THK
43	1	470562	IND BELT, 2.00 X 15.00 .203THK
44	2	470563	IND BELT, 2.00 X 40.00 .203THK
45	1	473859	12MM-1.75 X 50MM FLANGE BOLT
46	2	470118	1/4UNC X 3/4 FLANGE HEX BOLT
47	1	650272	DECAL,200AMP ECM FUSE,STS '11

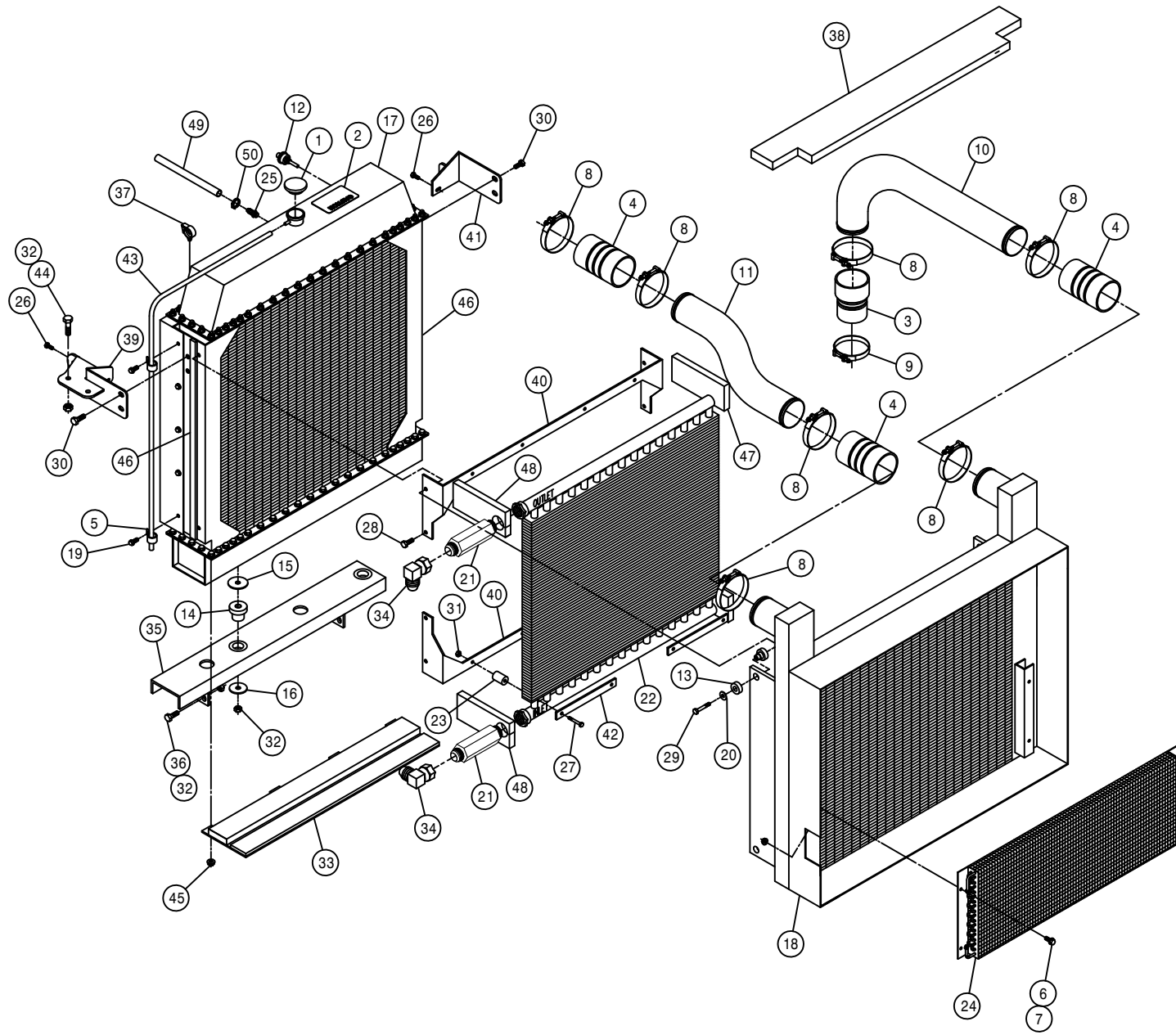

RADIATOR AND OIL COOLER ASSEMBLY

DET.	QTY	PART NO.	DESCRIPTION
1	1	316377	RAD CAP, 10LB 10237
2	1	650174	DECAL, CAUTION RADIATOR, STS 07
3	1	311500	3.50-3.00 X 6.40 REDU CAC HOSE
4	3	311501	3.50 X 6.00 CAC HOSE
5	2	520128	CUSH J CLAMP, #9 9/16D X 3/4W
6	4	470121	1/4UNC HEX FLANGE LOCK NUT
7	4	470122	1/4UNC X 1/2 FLANGE HEX BOLT
8	7	520145	3.56/3.88 T-BOLT HOSE CLAMP SS
9	1	520146	3.06/3.38 T-BOLT HOSE CLAMP SS
10	1	311540	PIPE, CAC TO ENG, STS T3 07
11	1	311539	PIPE, TURBO TO CAC, STS T3 07
12	1	291935	RAD WATER LEVEL SENSOR, T3 ENG
13	4	311056	RUBBER MOUNT SET, 2-PC CB 2320
14	2	311060	RUBBER MOUNT, 1-PC CB-1122-2
15	2	311061	HEAD WASHER FOR 311060
16	2	311062	TAIL WASHER FOR 311060
17	1	316364	RADIATOR, STS12 2000
18	1	316660	CHARGE AIR COOLER, STS TIER3 06
19	10	470319	3/8UNC X 1/2 SERR FLANGE BOLT
20	4	483043	3/8 REGULAR FLAT WASHER
21	2	618830	1 5/16MJ-1 5/16MOR 6.0LG ADPTR
22	1	618800	OIL COOLER STS12 2000
23	8	618801	MOUNTING KIT FOR 618800 COOLER
24	1	657434	A/C CONDENSER COIL 21-0302
25	1	783304	1/4 NPT X 3/8 HOSE BARB, BRS
26	2	470233	5/16UNC X 3/4 FLANGE HEX BOLT
27	8	900071	5/16UNC X 2 3/4 HEX BOLT
28	4	900128	3/8UNC X 3/4 HEX BOLT
29	4	900133	3/8UNC X 2" SERR FLANGE BOLT
30	4	900264	1/2UNC X 1 1/4 HEX BOLT
31	8	473001	5/16UNC HEX NUT, NYLOC 316 SS
32	8	914008	1/2UNC HEX STOVER NUT
33	1	316490	LWR RADIATOR FILLER PANEL ASSY
34	2	618640	1 5/16MJ-90-1 5/16FJ SWIV LBO
35	1	316594	RADIATOR MT CHAN WLD, STS 04
36	4	900264	1/2UNC X 1 1/4 HEX BOLT
37	4	291008	ROSEBUD CLIP FOR .350 CONDUIT
38	1	316588	FOAM, STS 04
39	1	316727	UPPER LH RAD MT WLD, STS T3 07
40	2	316452	RAD TO OIL COOLER MT
41	1	316446	UPPER RH RAD MT WLD 2000
42	4	316453	RAD TO OIL COOLER KEEPER
43	1	601614	HOSE, 5/16 X 64 EPDM
44	2	900264	1/2UNC X 1 1/4 HEX BOLT
45	4	470113	5/16UNC HEX FLANGE LOCK NUT
46	2	316493	SIDE FOAM, RAD/CAC
47	2	316494	RH UPR/LWR FOAM, OIL CLR/RAD 00
48	2	316495	LH UPR/LWR FOAM, OIL CLR/RAD 00
49	1	601668	HOSE, 3/8 X 30 HEATER
50	1	520069	HOSE CLAMP NO 6 STAINLESS

TO AIR BRAKE (REF)

AIR CLEANER ASSEMBLY

DET.	QTY	PART NO.	DESCRIPTION
1	2	193037	STICKERTITE 1/8 X 3/4
2	1	311538	PIPE,AIR CLEANER-TURBO,STS 07
3	1	311507	4.00" 45DEG ELBOW, RUBBER
4	1	311535	5.00-4.00 ID REDUCER BUSHING
5	1	311536	7"-5" REDU HUMP HOSE, RUBBER
6	1	311537	AIR CLEANER HOOD EXT,14"STS 07
7	1	311541	AIR CLEANER,OPTIAIR 1300
8	2	311542	AIR CLEANER MT BAND FOR 311541
9	1	311543	PRIMARY AIR FILTER FOR 311541
10	1	311544	SECONDARY FILTER FOR 311541
11	1	311545	7.00-6.00 REDUCER,STEEL W/CLMP
12	1	316277	AIR COMPRESSOR GOVERNOR KIT
13	1	470480	6" EASYSEAL CLAMP, SS
14	1	316684	FILTER,PRE FUEL 25 MICRON
15	2	520134	4.31/4.59 T-BOLT HOSE CLAMP SS
16	1	520148	5.38/5.69 T-BOLT HOSE CLAMP SS
17	1	520149	7.13/7.44 T-BOLT HOSE CLAMP SS
18	1	520150	7.38/7.69 T-BOLT HOSE CLAMP SS
19	1	520163	CUSH CLAMP,#8 1/2D X 3/4W
20	7	470087	3/8UNC HEX FLANGE LOCK NUT
21	4	470121	1/4UNC HEX FLANGE LOCK NUT
22	5	470460	3/8UNC X 1 SERR FLANGE BOLT
23	1	473782	12MM-1.75 X 18MM HEX BOLT
24	1	473784	12MM LOCK WASHER
25	2	473855	12MM-1.75 X 35MM FLANGE BOLT
26	1	520102	CUSH CLAMP,#20 1 1/4D X 1/2W
27	1	520101	CUSH CLAMP,#16 1"D X 1/2W
28	1	601707	HOSE, 1/4 X 63 AIR
29	1	311565	COVER ASSEMBLY FOR 311541
30	2	711036	1/8MNPT-1/4 NYL TUBE FTG
31	1	711039	1/8MNPT-90-1/4 NYL TUBE LBO
32	2	900072	5/16UNC X 3" HEX BOLT
33	2	900129	3/8UNC X 1" SERR FLANGE BOLT
34	2	901255	1/2UNC X 1 1/2 CARR BOLT
35	2	914002	5/16UNC HEX STOVER NUT
36	2	914008	1/2UNC HEX STOVER NUT
37	1	316796	AIR CLEANER MT WLD, STS T3 07
38	1	316716	RH FRT HOOD BRACE, STS T3 07
39	1	316795	AIR INTAKE SUPP, STS10/12 07
40	1	520069	HOSE CLAMP NO 6 STAINLESS
41	1	601625	HOSE, 1/4 X 14 AIR
42	1	601554	HOSE, 1/4 X 46 AIR
43	4	470118	1/4UNC X 3/4 FLANGE HEX BOLT
44	1	311520	ENGINE PRE CLEANER
45	1	293880	JUMPER WIRE ASSY(DEUTSCH)
46	1	293568	PRESS SWITCH HARNESS,STS16 05
47	1	311082	AIR VALVE ASSY,STS16-GST20 05
48	1	311083	PRESSURE SWITCH,80PSI,12VDC
49	1	316656	E-BRAKE CTRL VLV MT,STSL16 06
50	2	470402	1/4MNPT MUFFLER
51	2	470463	8-32 SERR. FLANGE NUT
52	1	611352	04-213-04FJX-04FJX-25 H/A
53	1	601671	HOSE, 1/4 X 145 AIR
54	1	711049	1/4 NYL TUBE-1/4MNPT FTG
55	1	711057	7/16MJIC-1/4MNPT ADPTR BRS
56	1	711060	1/4 UNION TEE BRS
57	1	711061	1/4NPT PLUG, SKT HEX HEAD BRS
58	2	903855	8-32 X 1 1/2 PHIL PAN HD SCR
59	2	502707	PIPE NIPPLE,1/4NPT HEX, BRS

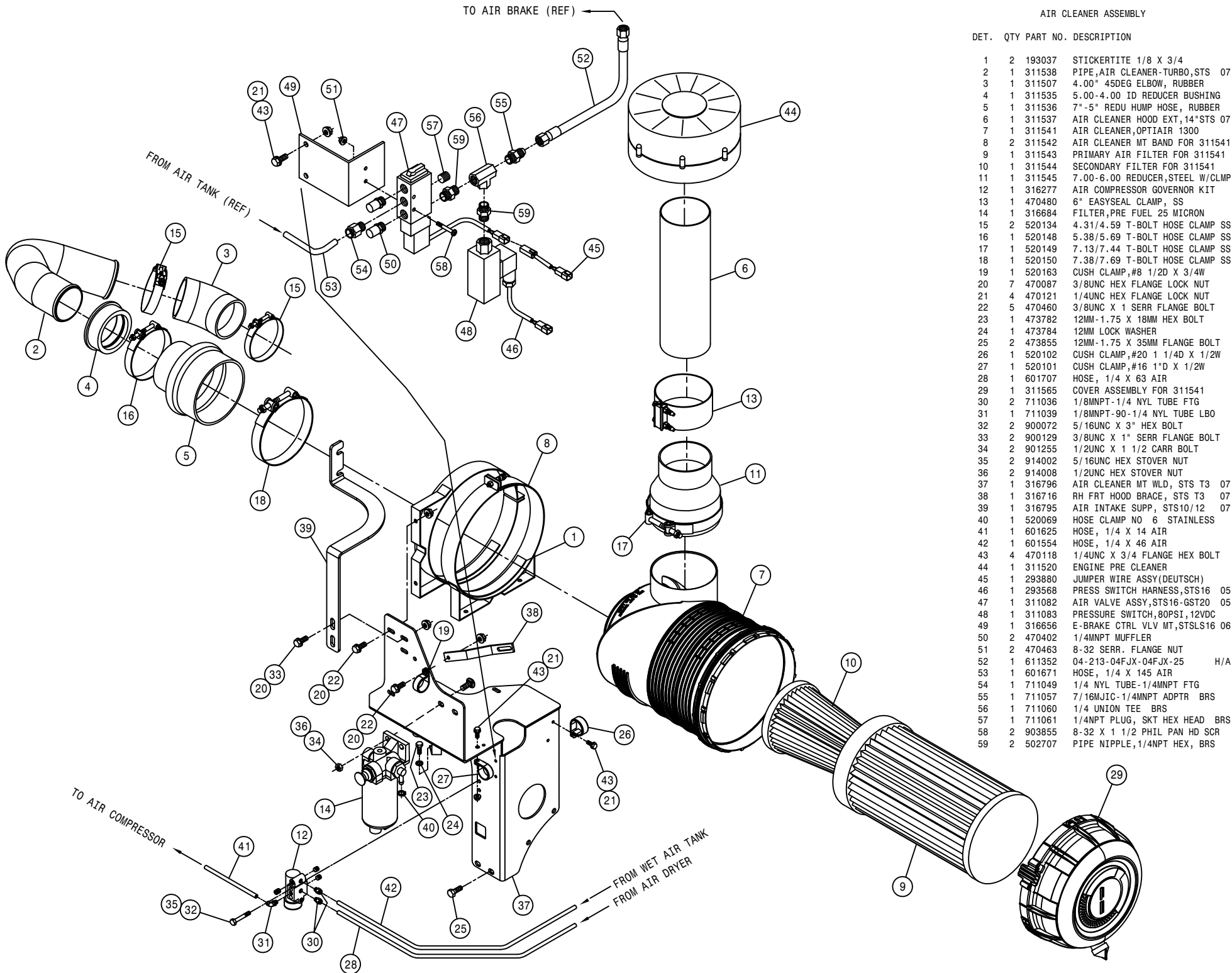

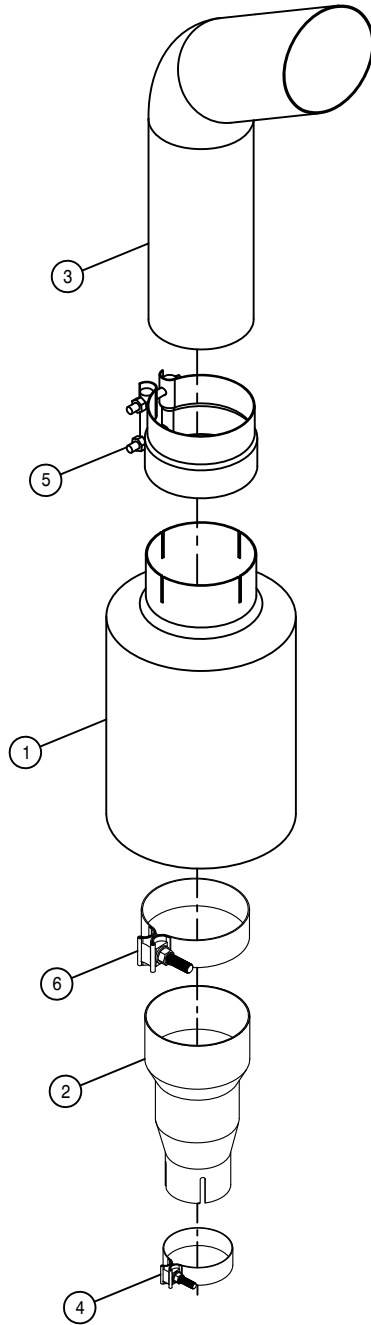
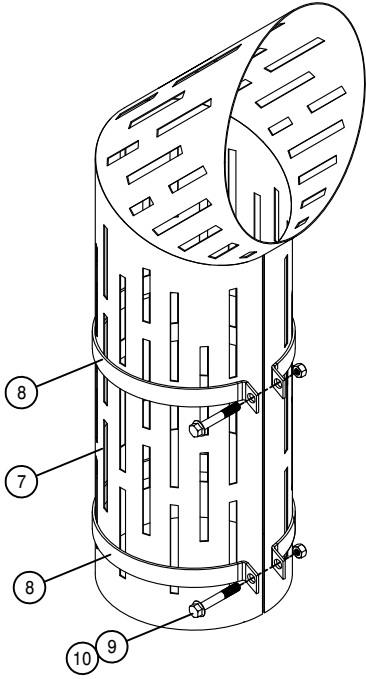

MUFFLER ASSEMBLY

DET. QTY PART NO. DESCRIPTION

DET.	QTY	PART NO.	DESCRIPTION
1	1	316657	MUFFLER 5"
2	1	316816	EXH REDUCER CONNECTOR
3	1	316817	EXHAUST STACK ,ANGLED
4	1	470458	MUFFLER CLAMP, 3.00 ACCUSEAL
5	1	470477	5" LAP EXHAUST CLAMP
6	1	470600	MUFFLER CLAMP, 5.00 ACCUSEAL
7	1	343794	MUFFLER GUARD WLD,STS '11
8	2	343796	MUFFLER GUARD CLMP BAND,STS'11
9	2	900134	3/8UNC X 2 1/2 SER FLANGE BOLT
10	2	914004	3/8UNC HEX STOVER NUT

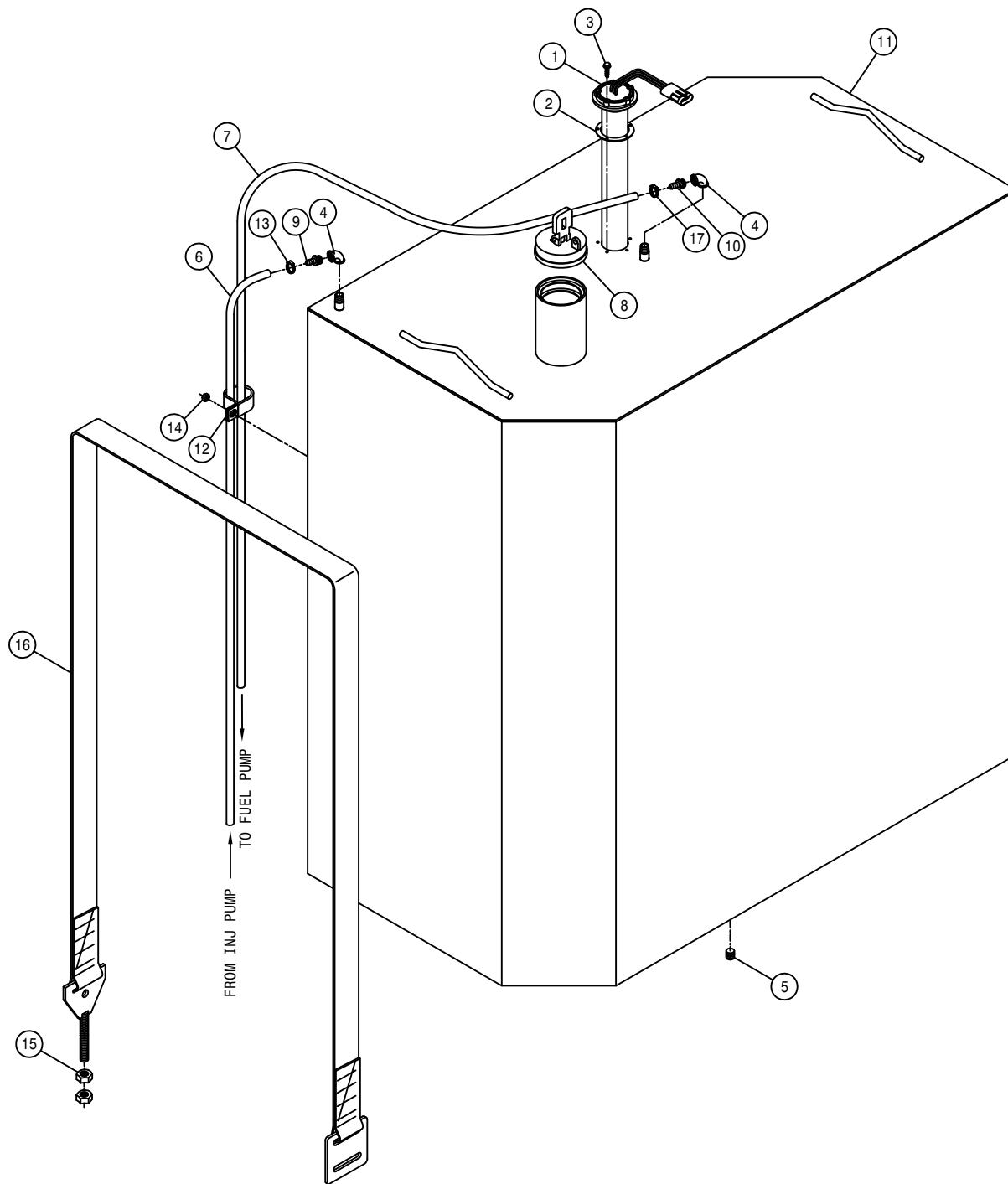

FUEL TANK ASSEMBLY

DET. QTY PART NO. DESCRIPTION

1	1	291354	FUEL LEVEL SENDER	05
2	1	291789	GASKET FOR FUEL SENDER 291788	
3	5	903905	10-32X1 1/2 PHIL PAN MACH SCR	
4	2	501451	BLK PIPE EL 90DEG .25NPT	
5	1	470308	1/2MNPT DRAIN PLUG,AL HD,MAG	
6	1	601666	HOSE, 5/16 X 68 FUEL LINE	
7	1	601746	HOSE, 3/8 X 79 FUEL LINE	
8	1	760469	FUEL TANK CAP,3.50" VENTED	
9	1	783303	1/4 NPT X 5/16 HOSE BARB, BRS	
10	1	783304	1/4 NPT X 3/8 HOSE BARB, BRS	
11	1	760473	FUEL TANK WLDMT, STS/GST	06
12	1	520101	CUSH CLAMP,#16 1"D X 1/2W	
13	1	520120	HOSE CLAMP NO 4 STAINLESS	
14	1	914000	1/4UNC HEX STOVER NUT	
15	4	910008	1/2UNC HEX NUT	
16	2	316575	FUEL TANK STRAP ASSY, STS	04
17	1	520069	HOSE CLAMP NO 6 STAINLESS	

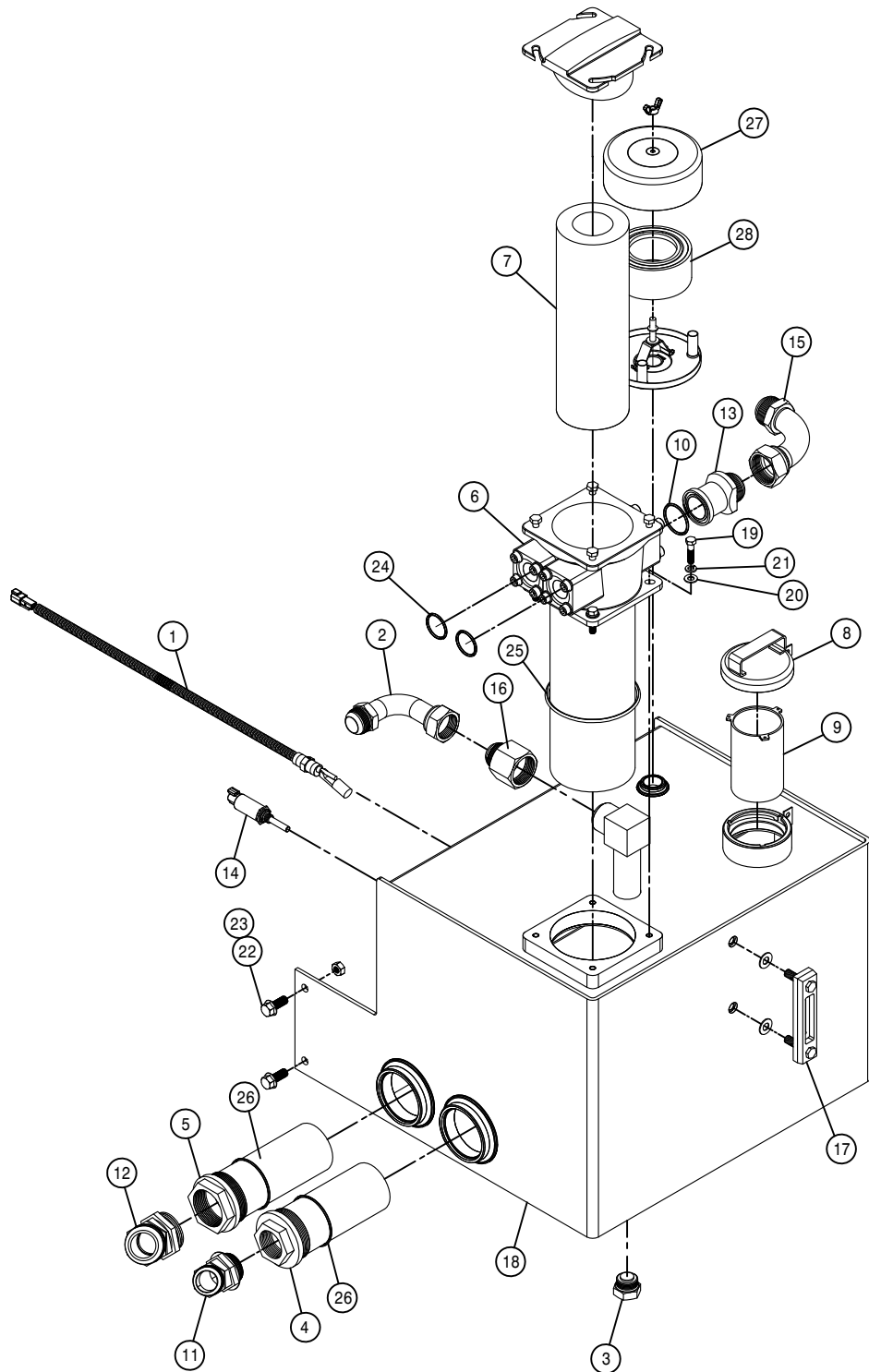

HYDRAULIC TANK ASSEMBLY

DET. QTY PART NO. DESCRIPTION

1	1	293815	LIQUID LEV SWITCH ASSY,1/2NPO5
2	1	618768	1 5/8MJIC-90-1 5/8FJX TUBE
3	1	470471	1 5/16MOR PLUG, MAGNETIC
4	1	605622	SUCTION STRAINER,21GPM 100M 24
5	1	605623	SUCTION STRAINER,39GPM 100M 32
6	1	605625	IN-TANK RETURN FILTER, 10M
7	1	605626	FILTER ELEMENT FOR 605625 10M
8	1	605646	FILL CAP-HYD RSRVR NON-VENTED
9	1	605645	STRAINER-HYD RSRVR
10	1	618395	O-RING FOR 1 1/2" FLANGE -24
11	1	618745	1 7/8MJIC-45-1 7/8MOR LBO
12	1	618746	2 1/2MJIC-45-2 1/2MOR LBO
13	1	618747	1 1/2 FLANGE-1 7/8MJIC ADPTR
14	1	291995	TEMPERATURE TRANSDUCER,HYDAC
15	1	618764	1 7/8MJIC-90-1 7/8FJX TUBE LBO
16	1	618767	1 7/8FJIC-1 5/8MJIC ADPTR
17	1	760177	SIGHT GAUGE W/TEMP, HYD TANK
18	1	760732	HYD TANK WLD,STS10/12/14 '10
19	4	900131	3/8UNC X 1 1/2 HEX BOLT
20	4	920002	3/8 SAE FLAT WASHER
21	4	920502	3/8 LOCK WASHER
22	4	900264	1/2UNC X 1 1/4 HEX BOLT
23	4	914008	1/2UNC HEX STOVER NUT
24	2	618465	O-RING FOR 1 1/4" FLANGE, -20
25	1	605632	O-RING,-357,FILTER HEAD 605625
26	2	605638	O-RING,-48 3.228ID-.118W
27	1	605647	BREATHER-HYD RSRVR
28	1	605648	FOAM BREATHER, HYD RSRVR

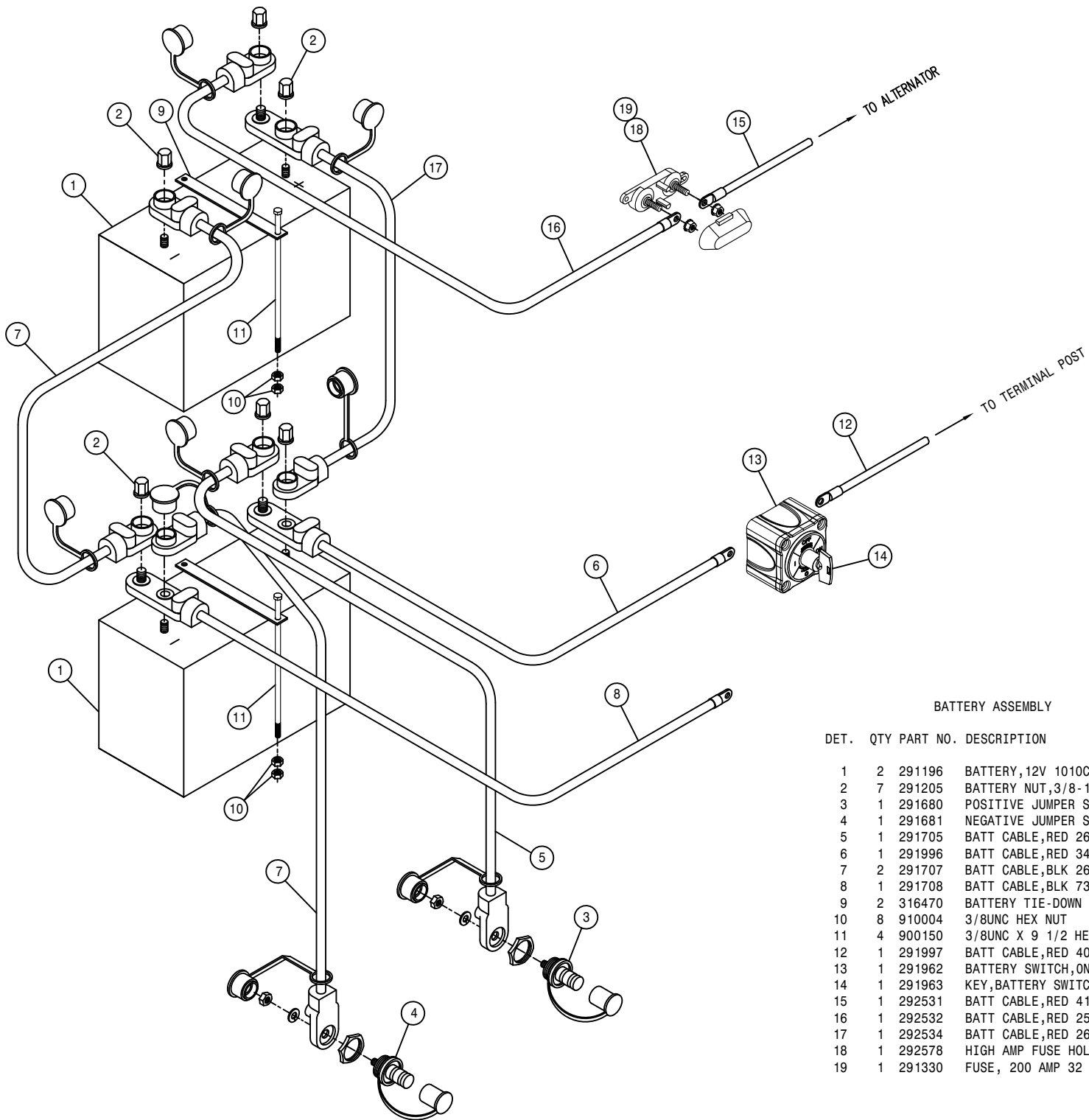

BATTERY ASSEMBLY

DET.	QTY	PART NO.	DESCRIPTION
	2	291196	BATTERY,12V 1010CCA, SS STUD
	7	291205	BATTERY NUT,3/8-16 SS CLSD CAP
	1	291680	POSITIVE JUMPER STUD, RED
	1	291681	NEGATIVE JUMPER STUD, BLACK
	1	291705	BATT CABLE,RED 26"2/0 3/8-3/8
	1	291996	BATT CABLE,RED 34"2/0 3/8-3/8
	2	291707	BATT CABLE,BLK 26"2/0 3/8-3/8
	1	291708	BATT CABLE,BLK 73"2/0 3/8-3/8
	2	316470	BATTERY TIE-DOWN
	8	910004	3/8UNC HEX NUT
	4	900150	3/8UNC X 9 1/2 HEX BOLT
	1	291997	BATT CABLE,RED 40"2/0 3/8-3/8
	1	291962	BATTERY SWITCH,ON/OFF(KEY)6005
	1	291963	KEY,BATTERY SWITCH 291962
	1	292531	BATT CABLE,RED 41"1/0.312-.343
	1	292532	BATT CABLE,RED 25"1/0.312-.375
	1	292534	BATT CABLE,RED 26"2/0.375-.375
	1	292578	HIGH AMP FUSE HOLDER W/COVER
	1	291330	FUSE, 200 AMP 32 VOLT DC

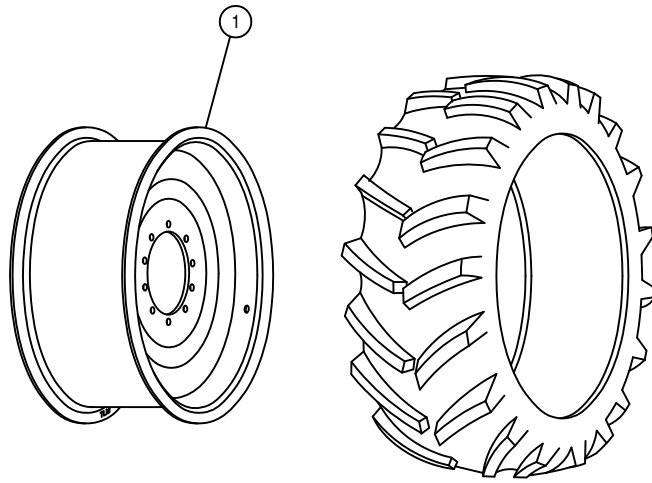

580/70 R38 RADIAL TIRE

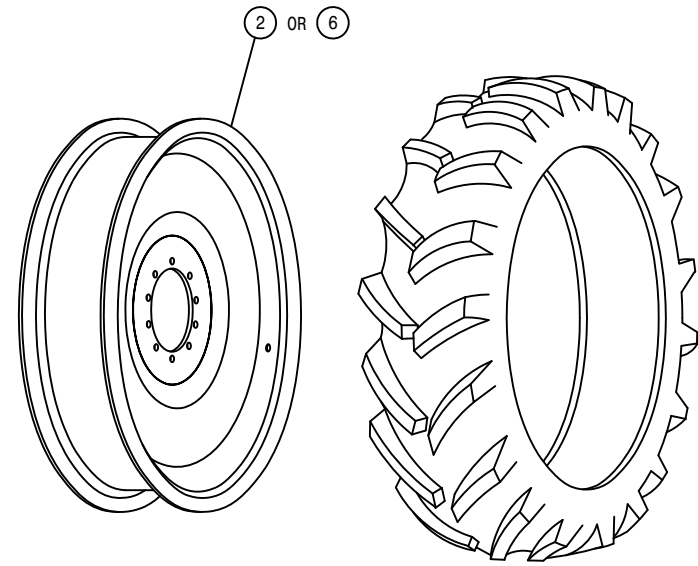

380/90 R46 RADIAL TIRE

520/85 R46 RADIAL TIRE

TIRE AND RIM ASSEMBLY

DET. QTY PART NO. DESCRIPTION

1	1	821055	RIM WLD, 38 X W18A	STS12
2	1	821054	RIM WLD, 46 X W13A	STS12
3	1	821053	RIM WLD, 50 X DW10	STS
4	1	821058	RIM WLD, 54 X W10A	
5	1	821059	RIM WLD, 54 X W12	
6	1	821061	RIM WLD, 46 X W16	

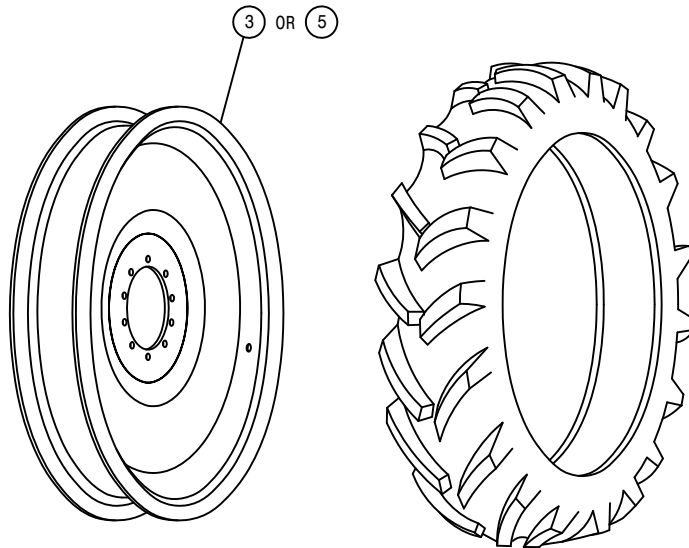

320/90 R50 RADIAL TIRE

380/90 R54 RADIAL TIRE

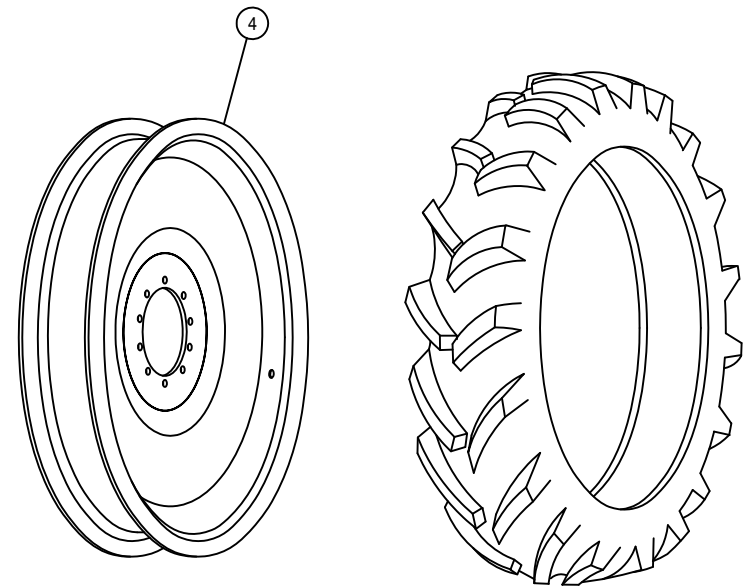

320/105 R54 RADIAL TIRE

RIGHT FRONT OUTER LEG ASSEMBLY

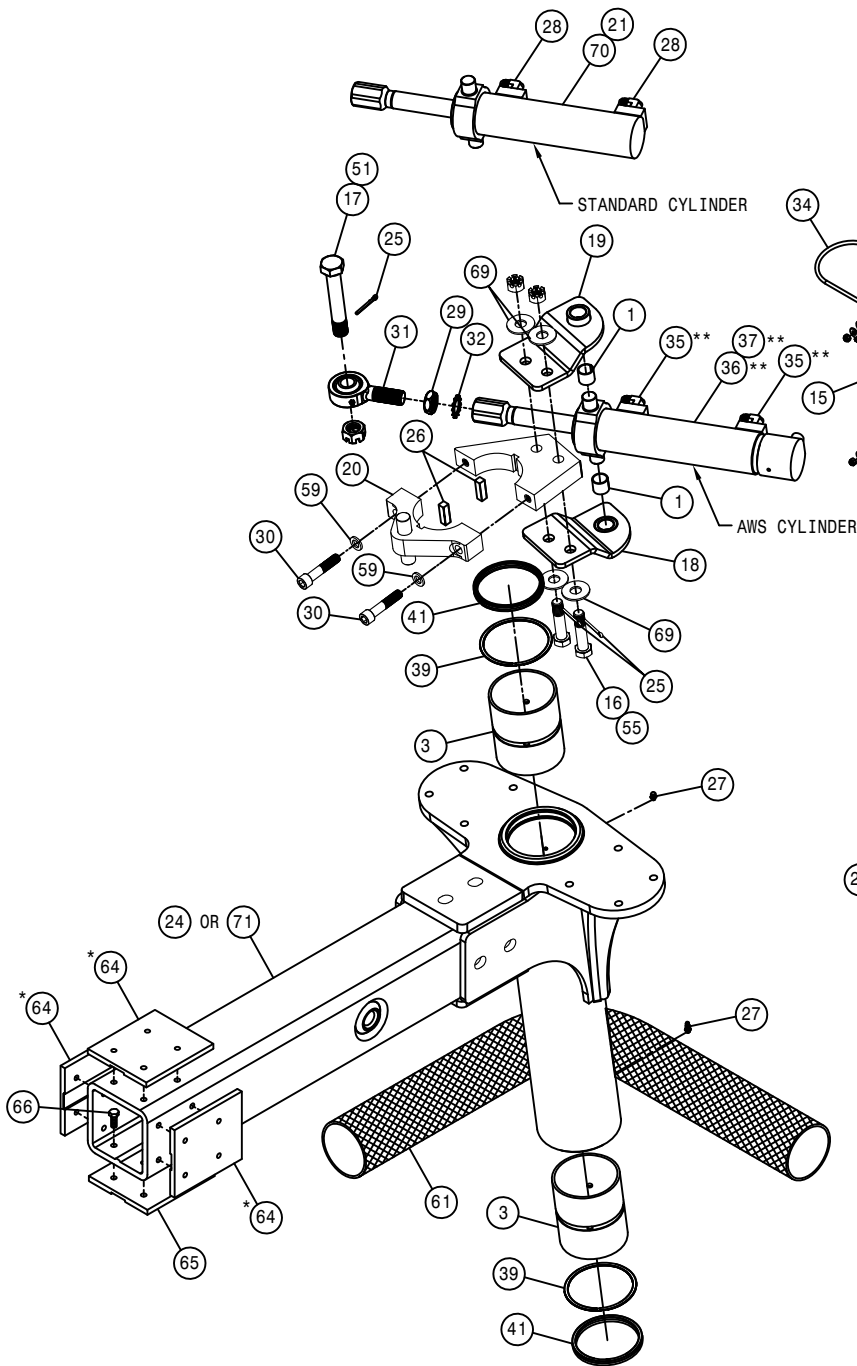

DET.	QTY	PART NO.	DESCRIPTION
1	2	121029	JOURNAL BRG, 1.00 ID X 1.00 LG
2	4	121113	TOWER SLEEVE BRG (POLYGON) 05
3	2	121120	LEG SLEEVE BRG,AWS (POLYGON) 09
4	1	125050	BRG CONE,1.00 ID W/FACE SEAL
5	1	125051	BRG CUP FOR 125050
6	1	125052	BRG CONE, 2.687 ID W/FACE SEAL
7	1	125053	BRG CUP FOR 125052
8	2	311058	RUBBER SPRING
9	1	311080	AIRIDE SPRING, 11.81 BASE
10	1	358832	AIRIDE SPRING CTRL VALVE 98
11	1	359619	HOSE SUPPORT,FRT STS 54" '10
12	1	359333	AIRBAG TOWER TOP MT WLD,STS 05
13	1	359350	RH EXTENDED HOSE SUPPORT, STS
14	1	359369	RH LEG AIR VALVE MT, STS16 05
15	1	359544	LEG HEIGHT CTRL LINK,AWS STS09
16	2	359545	TRUNION MT BOLT, AWS STS 09
17	1	359546	STRG CYL BOLT, AWS STS 09
18	1	359547	TOP TRUNION MT WLD, AWS STS 09
19	1	359548	BTM TRUNION MT WLD, AWS STS 09
20	1	359593	STRG ARM CLAMP WLD,STS '10
21	1	621551	REPAIR KIT,HYD CYL,STRG 621550
22	1	359556	RH AIR BAG LWR PLT WLD,AWS STS
23	2	359563	NITRO TOWER WLD, AWS STS 09
24	1	359568	OUTER LEG WLDMT,96D AWS STS 09
25	3	470117	COTTER PIN 3/16 1 3/4 SQ CUT
26	2	470447	KEY, .50 SQ X 1.69 LG
27	5	471005	GREASE ZERK, 1/4 28 X 1/2
28	2	618249	3/4MJIC-90-9/16MOR LBO
29	1	472328	1" -12 HEX JAM NUT
30	2	472337	5/8 X 3" SOCKET HD CAP SCR
31	1	473975	ROD END,1.00 BORE,1-12 RH MALE
32	1	483018	1" EXTERNAL TOOTH LOCK WASHER
33	1	520164	CUSH CLAMP,9/16D-3/4W-.531MT
34	1	601473	HOSE, 1/4 X 18 AIR
35	2	618241	3/4MJIC-90-3/4MOR LBO
36	1	621602	HYD CYL,2.50 X 8.81 PHASE/SENS
37	1	621604	REPAIR KIT, HYD CYL 621602/603
38	8	629537	187RRHOZ SNAP RING
39	2	629538	4.5 SPIROLOX RING
40	4	629620	SEAL, 1.500 ROD DIA
41	2	629621	SEAL, 4.500 ROD DIA
42	2	711036	1/8MNPT-1/4 NYL TUBE FTG
43	1	711040	1/4MNPT-90-1/4 NYL TUBE LBO
44	2	900002	1/4UNC X 3/4 HEX BOLT
45	4	900265	1/2UNC X 1 1/2 HEX BOLT
46	4	900267	1/2UNC X 2" HEX BOLT
47	4	900268	1/2UNC X 2 1/2 HEX BOLT
48	4	900269	1/2UNC X 2 3/4 HEX BOLT
49	1	910008	1/2UNC HEX NUT
50	1	910013	3/4UNF HEX NUT
51	1	910020	1-8 HEX SLOTTED NUT
52	1	910021	1-14 SLOT JAM NUT
53	2	914000	1/4UNC HEX STOVER NUT
54	12	914008	1/2UNC HEX STOVER NUT
55	2	910102	3/4UNC SLOT HEX NUT, GR8
56	1	920008	1" SAE FLAT WASHER
57	1	920504	1/2 LOCK WASHER
58	1	920506	3/4 LOCK WASHER
59	2	473841	16MM LOCK WASHER
60	1	601642	HOSE, 1/4 X 256 AIR
61	1	470310	SIDEWINDER SLEEVE,14.06 X 45"
62	1	470305	HOSE CLAMP, 4-HOLE
63	1	359094	HYD TUBE CLAMP KEEPER, 5.75
64	3	342917	TREAD ADJ PLATE, STEEL, THD
65	4	342719	TRD ADJ BRONZE BEARING,THD-GRV
66	16	900128	3/8UNC X 3/4 HEX BOLT
67	2	900138	3/8UNC X 3 1/2 HEX BOLT
68	2	914004	3/8UNC HEX STOVER NUT
69	4	483048	3/4 REG FLAT WASH,THRU-HARD
70	1	621550	HYD CYL, 2.50 X 8.81 X 1.250
71	1	359632	OUTER LEG WLDMT,96D AWS STS' 11

NOTE: (*) FOR TREAD ADJUST OPTION REPLACE ITEM 64 WITH THREE OF ITEM 65.

(**) ITEMS ARE FOR ALL WHEEL STEER OPTION.

RH FRONT INNER LEG ASSEMBLY (BONFIGLIOLI HUB)

DET. QTY PART NO. DESCRIPTION

1	1	359565	INNER LEG WLD, AWS STS	09
2	1	470117	COTTER PIN 3/16 1 3/4 SQ CUT	
3	1	470305	HOSE CLAMP, 4-HOLE	
4	1	359396	RH WHL MTR SHIELD,SS STS12L 06	
5	1	359404	RH WHL MTR SHIELD,STL STS12L06	
6	20	473840	16MM-2.00 X 40MM SOCKET CAP SCR	
7	20	473841	16MM LOCK WASHER	
8	1	606288	WHL MOTOR,51C060 SAUER	
9	1	610968	WHEEL HUB,26:1 W/BRAKE BONFIG	
10	2	618431	3/4 (-12) SPLIT FLANGE KIT #62	
11	2	870214	BUNA ORING 1 X 1 1/4	
12	10	824055	22MM-1.50 FLANGED WHEEL NUT	
13	2	900138	3/8UNC X 3 1/2 HEX BOLT	
14	3	473987	1/2UNC X 1 1/4 BUT SKTHD SCR SS	
15	2	900265	1/2UNC X 1 1/2 HEX BOLT	
16	2	914004	3/8UNC HEX STOVER NUT	
17	6	914008	1/2UNC HEX STOVER NUT	
18	1	618812	3/4 FLANGE-1 7/16MFOR ADPTR	
19	2	359102	WHL MTR SHIELD BRACE	
20	1	359624	RH LWR FENDER MT WLD, STS '10	
21	1	359094	HYD TUBE CLAMP KEEPER, 5.75	
22	1	470379	SIDEWINDER SLEEVE,14.06 X 57"	
23	1	618740	3/4 FLANGE-90-1 7/16MFOR LBO	
24	1	618469	3/4MJIC-1 1/16MOR ADPTR	
25	1	470378	SIDEWINDER SLEEVE,14.06 X 21"	
26	1	615875	WHEEL MOTOR HYD TUBE ASSY	
27	4	900266	1/2UNC X 1 3/4 HEX BOLT	
28	2	359367	BUSHING, CROP SHIELD, STS 05	
29	3	473988	1/2UNC HEX NUT, NYLOC SS	
30	1	618677	O-RING, -16 FACE SEAL .93ID 90D	
31	1	293848	WHL MTR JMPR HARNESS,STS16 05	
32	1	606321	SOLENOID, WHL MTR 606288/291	
33	1	618467	7/16MJIC-7/16MOR ADPTR	

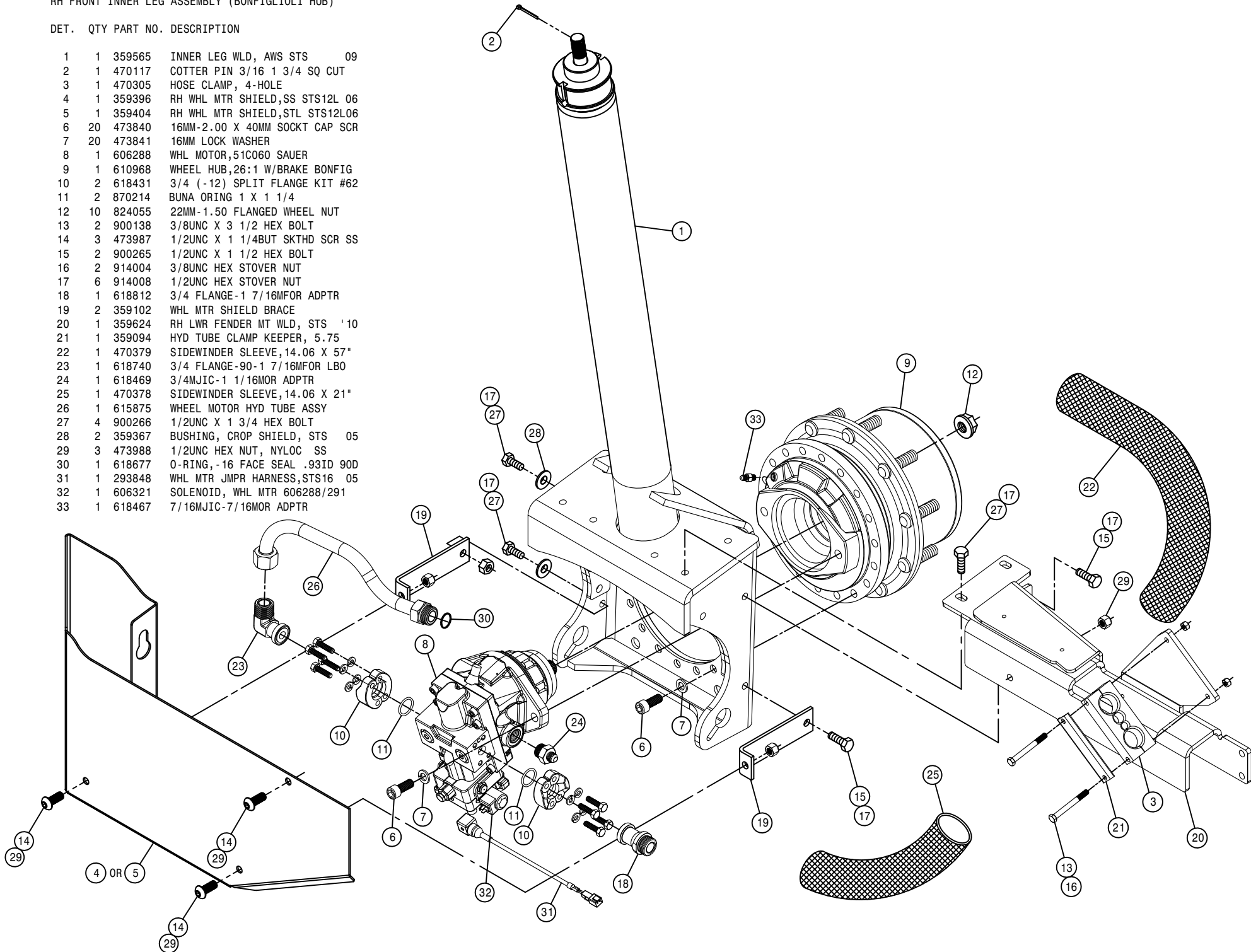

LEFT FRONT OUTER LEG ASSEMBLY

DET. QTY PART NO. DESCRIPTION

1	2	121029	JOURNAL BRG, 1.00 ID X 1.00 LG
2	4	121113	TOWER SLEEVE BRG (POLYGON) 05
3	2	121120	LEG SLEEVE BRG,AWS (POLYGON)09
4	1	125050	BRG CONE,1.00 ID W/FACE SEAL
5	1	125051	BRG CUP FOR 125050
6	1	125052	BRG CONE, 2.687 ID W/FACE SEAL
7	1	125053	BRG CUP FOR 125052
8	2	311058	RUBBER SPRING
9	1	311080	AIRIDE SPRING, 11.81 BASE
10	1	358832	AIRIDE SPRING CTRL VALVE 98
11	1	359619	HOSE SUPPORT,FRT STS 54" '10
12	1	359333	AIRBAG TOWER TOP MT WLD,STS 05
13	1	359351	LH EXTENDED HOSE SUPPORT, STS
14	1	359370	LH LEG AIR VALVE MT, STS16 05
15	1	359544	LEG HEIGHT CTRL LINK,AWS STS09
16	2	359545	TRUNION MT BOLT, AWS STS 09
17	1	359546	STRG CYL BOLT, AWS STS 09
18	1	359547	TOP TRUNION MT WLD, AWS STS 09
19	1	359548	BTM TRUNION MT WLD, AWS STS 09
20	1	359593	STRG ARM CLAMP WLD,STS '10
21	1	621551	REPAIR KIT,HYD CYL,STRG 621550
22	1	359557	LH AIR BAG LWR PLT WLD,AWS STS
23	2	359563	NITRO TOWER WLD, AWS STS 09
24	1	359568	OUTER LEG WLDMT,98D AWS STS 09
25	3	470117	COTTER PIN 3/16 1 3/4 SQ CUT
26	2	470447	KEY, .50 SQ X 1.69 LG
27	5	471005	GREASE ZERK, 1/4 28 X 1/2
28	2	618249	3/4MJIC-90-9/16MOR LBO
29	1	472328	1" -12 HEX JAM NUT
30	2	472337	5/8 X 3" SOCKET HD CAP SCR
31	1	473975	ROD END,1.00 BORE,1-12 RH MALE
32	1	483018	1" EXTERNAL TOOTH LOCK WASHER
33	1	520164	CUSH CLAMP,9/16D-3/4W-.531MT
34	1	601473	HOSE, 1/4 X 18 AIR
35	2	618241	3/4MJIC-90-3/4MOR LBO
36	1	621602	HYD CYL,2.50 X 8.81 PHASE/SENS
37	1	621604	REPAIR KIT, HYD CYL 621602/603
38	8	629537	187RRHOOZ SNAP RING
39	2	629538	4.5 SPIROLOX RING
40	4	629620	SEAL, 1.500 ROD DIA
41	2	629621	SEAL, 4.500 ROD DIA
42	2	711036	1/8MNPT-1/4 NYL TUBE FTG
43	1	711040	1/4MNPT-90-1/4 NYL TUBE LBO
44	2	900002	1/4UNC X 3/4 HEX BOLT
45	4	900265	1/2UNC X 1 1/2 HEX BOLT
46	4	900267	1/2UNC X 2" HEX BOLT
47	4	900268	1/2UNC X 2 1/2 HEX BOLT
48	4	900269	1/2UNC X 2 3/4 HEX BOLT
49	1	910008	1/2UNC HEX NUT
50	1	910013	3/4UNF HEX NUT
51	1	910020	1-8 HEX SLOTTED NUT
52	1	910021	1-14 SLOT JAM NUT
53	2	914000	1/4UNC HEX STOVER NUT
54	12	914008	1/2UNC HEX STOVER NUT
55	2	910102	3/4UNC SLOT HEX NUT, GR8
56	1	920008	1" SAE FLAT WASHER
57	1	920504	1/2 LOCK WASHER
58	1	920506	3/4 LOCK WASHER
59	2	473841	16MM LOCK WASHER
60	1	601641	HOSE, 1/4 X 222 AIR
61	1	470310	SIDEWINDER SLEEVE,14.06 X 45"
62	1	470305	HOSE CLAMP, 4-HOLE
63	1	359094	HYD TUBE CLAMP KEEPER, 5.75
64	3	342917	TREAD ADJ PLATE, STEEL, THD
65	4	342719	TRD ADJ BRONZE BEARING,THD-GRV
66	16	900128	3/8UNC X 3/4 HEX BOLT
67	2	900138	3/8UNC X 3 1/2 HEX BOLT
68	2	914004	3/8UNC HEX STOVER NUT
69	4	483048	3/4 REG FLAT WASH, THRU-HARD
70	1	621550	HYD CYL, 2.50 X 8.81 X 1.250
71	1	359632	OUTER LEG WLDMT,96D AWS STS'11

NOTE: (*) FOR TREAD ADJUST OPTION REPLACE ITEM 64 WITH THREE OF ITEM 65.

(**) ITEMS ARE FOR ALL WHEEL STEER OPTION.

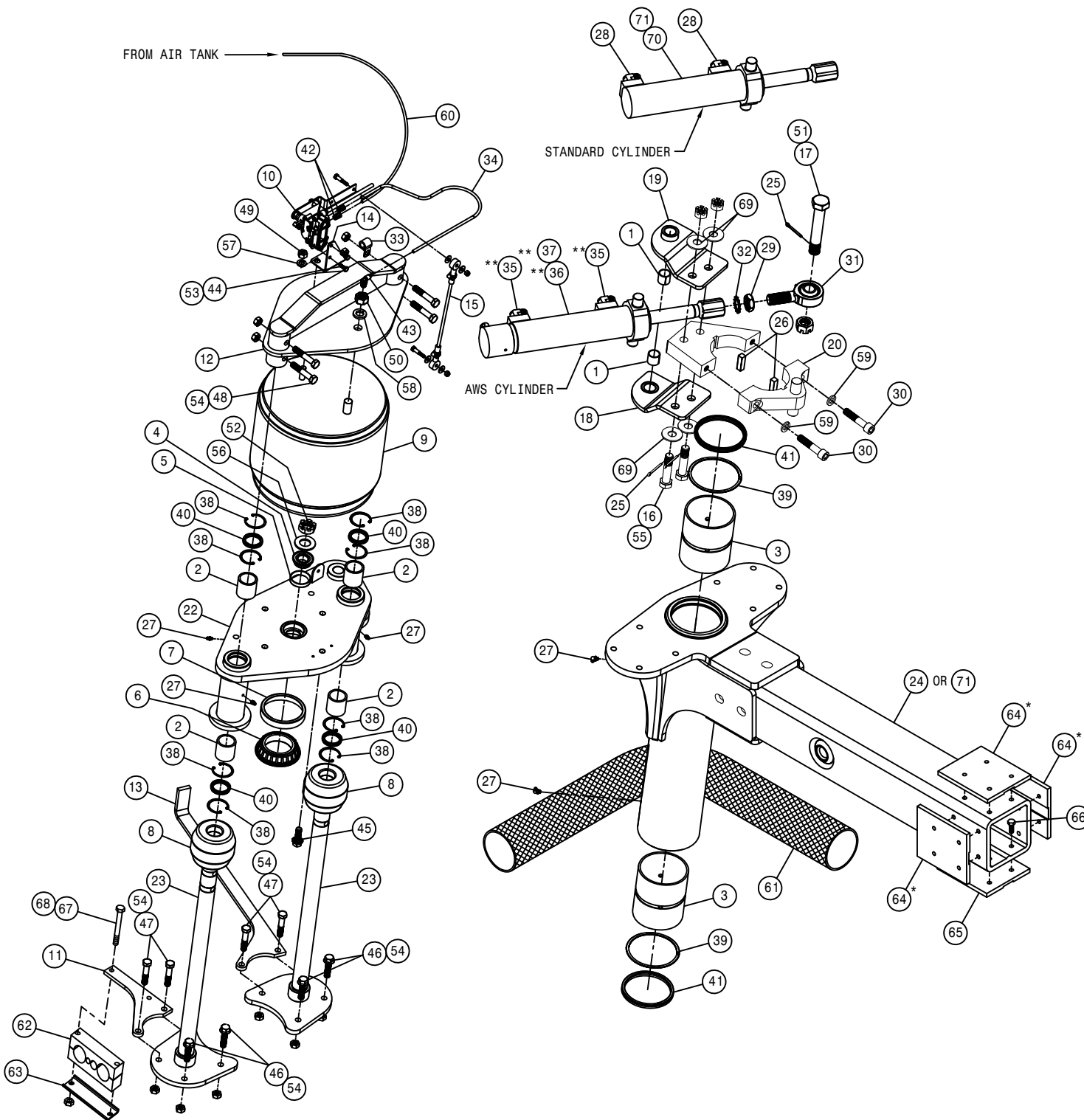

LH FRONT INNER LEG ASSEMBLY (BONIFIGLIOLI HUB)

DET. QTY PART NO. DESCRIPTION

DET.	QTY	PART NO.	DESCRIPTION
1	1	359565	INNER LEG WLD, AWS STS 09
2	1	470117	COTTER PIN 3/16 1 3/4 SQ CUT
3	1	470305	HOSE CLAMP, 4-HOLE
4	1	359397	LH WHL MTR SHIELD,SS STS12L 06
5	1	359405	LH WHL MTR SHIELD,STL STS12L06
6	20	473840	16MM-2.00 X 40MM SOCKT CAP SCR
7	20	473841	16MM LOCK WASHER
8	1	606288	WHL MOTOR,51C060 SAUER
9	1	610968	WHEEL HUB,26:1 W/BRAKE BONFIG
10	2	618431	3/4 (-12) SPLIT FLANGE KIT #62
11	2	870214	BUNA ORING 1 X 1 1/4
12	10	824055	22MM-1.50 FLANGED WHEEL NUT
13	2	900138	3/8UNC X 3 1/2 HEX BOLT
14	3	473987	1/2UNC X 1 1/4BUT SKTHD SCR SS
15	2	900265	1/2UNC X 1 1/2 HEX BOLT
16	2	914004	3/8UNC HEX STOVER NUT
17	6	914008	1/2UNC HEX STOVER NUT
18	1	618812	3/4 FLANGE-1 7/16MFOR ADPTR
19	2	359102	WHL MTR SHIELD BRACE
20	1	359625	LH LWR FENDER MT WLD, STS '10
21	1	359094	HYD TUBE CLAMP KEEPER, 5.75
22	1	470379	SIDEWINDER SLEEVE,14.06 X 57"
23	1	615875	WHEEL MOTOR HYD TUBE ASSY
24	1	618469	3/4MJIC-1 1/16MOR ADPTR
25	4	900266	1/2UNC X 1 3/4 HEX BOLT
26	1	470378	SIDEWINDER SLEEVE,14.06 X 21"
27	1	618740	3/4 FLANGE-90-1 7/16MFOR LBO
28	2	359367	BUSHING, CROP SHIELD, STS 05
29	3	473988	1/2UNC HEX NUT, NYLOC SS
30	1	618677	O-RING,-16 FACE SEAL .93ID 90D
31	1	293848	WHL MTR JMPR HARNESS,STS16 05
32	1	606321	SOLENOID, WHL MTR 606288/291
33	1	618467	7/16MJIC-7/16MOR ADPTR

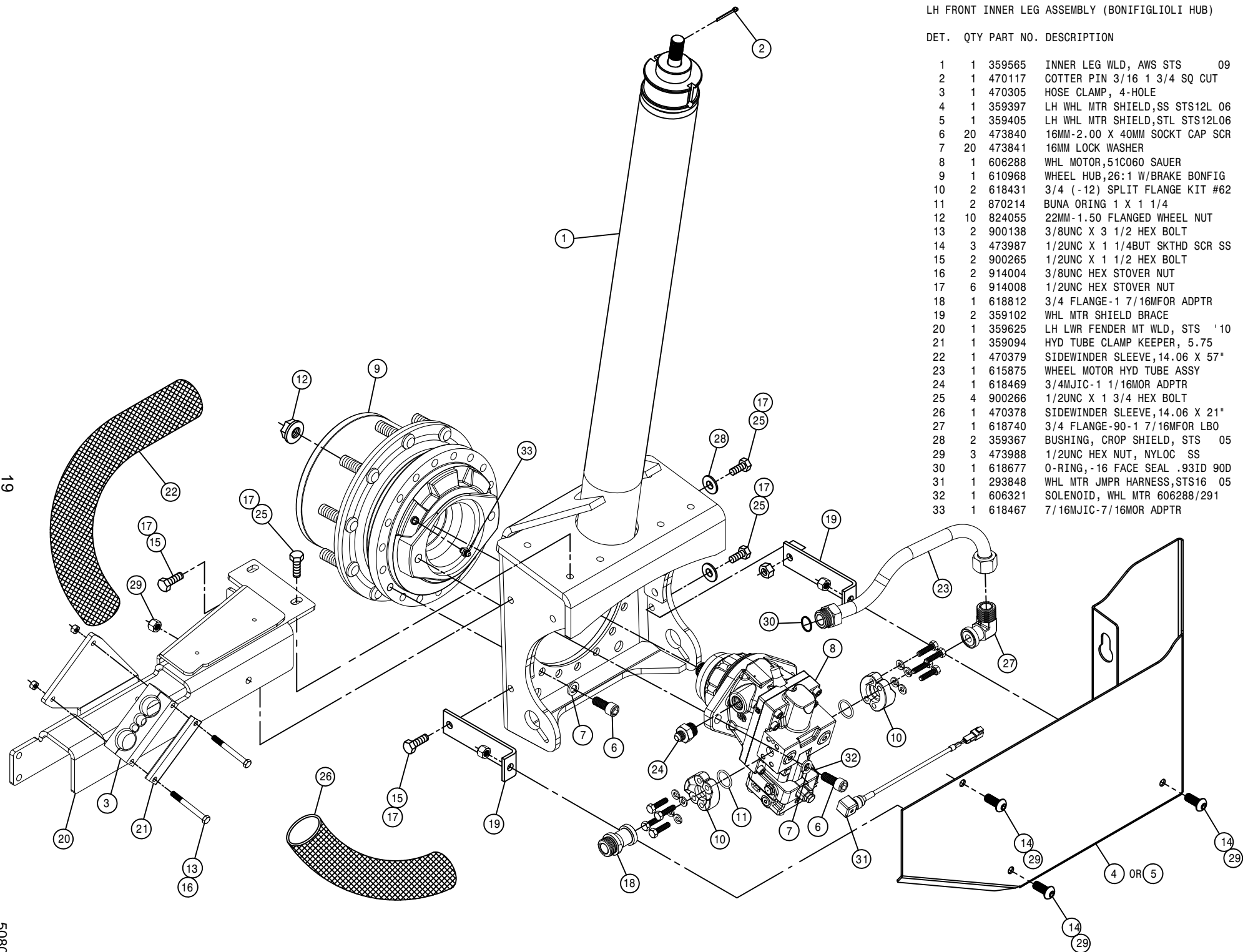

19

508019

RIGHT REAR OUTER LEG ASSEMBLY

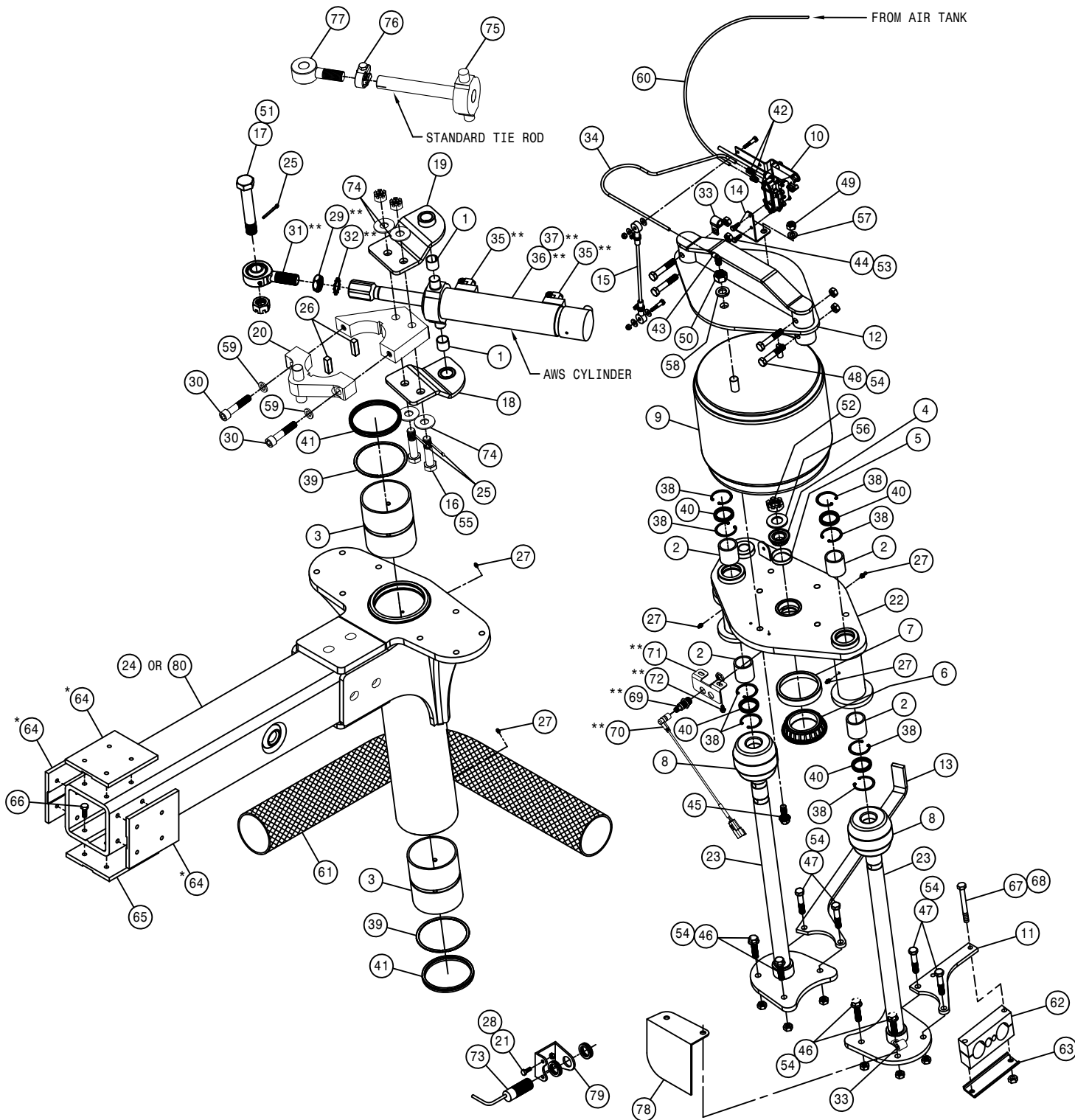

DET.	QTY	PART NO.	DESCRIPTION
1	2	121029	JOURNAL BRG, 1.00 ID X 1.00 LG
2	4	121113	TOWER SLEEVE BRG (POLYGON) 05
3	2	121120	LEG SLEEVE BRG,AWS (POLYGON)09
4	1	125050	BRG CONE,1.00 ID W/FACE SEAL
5	1	125051	BRG CUP FOR 125050
6	1	125052	BRG CONE, 2.687 ID W/FACE SEAL
7	1	125053	BRG CUP FOR 125052
8	2	311058	RUBBER SPRING
9	1	311080	AIRIDE SPRING, 11.81 BASE
10	1	358832	AIRIDE SPRING CTRL VALVE 98
11	1	359619	HOSE SUPPORT,FRT STS 54" '10
12	1	359333	AIRBAG TOWER TOP MT WLD,STS 05
13	1	359350	RH EXTENDED HOSE SUPPORT, STS
14	1	359369	RH LEG AIR VALVE MT, STS16 05
15	1	359544	LEG HEIGHT CTRL LINK,AWS STS09
16	2	359545	TRUNION MT BOLT, AWS STS 09
17	1	359546	STRG CYL BOLT, AWS STS 09
18	1	359547	TOP TRUNION MT WLD, AWS STS 09
19	1	359548	BTM TRUNION MT WLD, AWS STS 09
20	1	359593	STRG ARM CLAMP WLD,STS '10
21	2	900064	5/16UNC X 3/4 HEX BOLT
22	1	359556	RH AIR BAG LWR PLT WLD,AWS STS
23	2	359563	NITRO TOWER WLD, AWS STS 09
24	1	359568	OUTER LEG WLDMT,96D AWS STS 09
25	3	470117	COTTER PIN 3/16 1 3/4 SQ CUT
26	2	470447	KEY, .50 SQ X 1.69 LG
27	5	471005	GREASE ZERK, 1/4 28 X 1/2
28	2	914002	5/16UNC HEX STOVER NUT
29	1	472328	1"-12 HEX JAM NUT
30	2	472337	5/8 X 3" SOCKET HD CAP SCR
31	1	473975	ROD END,1.00 BORE,1-12 RH MALE
32	1	483018	1" EXTERNAL TOOTH LOCK WASHER
33	2	520164	CUSH CLAMP,9/16D-3/4W-.531MT
34	1	601473	HOSE, 1/4 X 18 AIR
35	2	618115	9/16MJIC-90-3/4MOR LBO
36	1	621603	HYD CYL,2.50 X 8.81 W/SENSOR
37	1	621604	REPAIR KIT, HYD CYL 621602/603
38	8	629537	187RRHOOD SNAP RING
39	2	629538	4.5 SPIROLOX RING
40	4	629620	SEAL, 1.500 ROD DIA
41	2	629621	SEAL, 4.500 ROD DIA
42	2	711036	1/8MNPT-1/4 NYL TUBE FTG
43	1	711040	1/4MNPT-90-1/4 NYL TUBE LBO
44	2	900002	1/4UNC X 3/4 HEX BOLT
45	4	900265	1/2UNC X 1 1/2 HEX BOLT
46	4	900267	1/2UNC X 2" HEX BOLT
47	4	900268	1/2UNC X 2 1/2 HEX BOLT
48	4	900269	1/2UNC X 2 3/4 HEX BOLT
49	1	910008	1/2UNC HEX NUT
50	1	910013	3/4UNF HEX NUT
51	1	910020	1-8 HEX SLOTTED NUT
52	1	910021	1-14 SLOT JAM NUT
53	2	914000	1/4UNC HEX STOVER NUT
54	12	914008	1/2UNC HEX STOVER NUT
55	2	910102	3/4UNC SLOT HEX NUT, GR8
56	1	920008	1" SAE FLAT WASHER
57	1	920504	1/2 LOCK WASHER
58	1	920506	3/4 LOCK WASHER
59	2	473841	16MM LOCK WASHER
60	1	601478	HOSE, 1/4 X 175 AIR
61	1	470311	SIDEWINDER SLEEVE,14.06 X 60"
62	1	470305	HOSE CLAMP, 4-HOLE
63	1	359094	HYD TUBE CLAMP KEEPER, 5.75
64	3	342917	TREAD ADJ PLATE, STEEL, THD
65	4	342719	TRD ADJ BRONZE BEARING,THD-GRV
66	16	900128	3/8UNC X 3/4 HEX BOLT
67	2	900138	3/8UNC X 3 1/2 HEX BOLT
68	2	914004	3/8UNC HEX STOVER NUT
69	1	291919	INDUCTIVE SENSOR
70	1	291994	SENSOR BRNKS,MICRO-DEUTSCH
71	1	359555	SENSOR BRKT, AWS STS 09
72	2	470122	1/4UNC X 1/2 FLANGE HEX BOLT
73	1	293827	SENSOR W/DEUTSCH ASSY STS 05
74	4	483048	3/4 REG FLAT WASH,THRU-HARD
75	1	359086	REAR TIE ROD SHAFT WLD
76	1	749322	STEERING TUBE CLAMP & BOLT ASSY
77	1	359089	TIE ROD STUD WLD
78	1	359092	RH SENSOR REFLECTOR
79	1	342856	TREAD SENSOR MT
80	1	359632	OUTER LEG WLDMT,96D AWS STS '11

NOTE: (*) FOR TREAD ADJUST OPTION REPLACE ITEM 64 WITH THREE OF ITEM 65.

(**) ITEMS ARE FOR ALL WHEEL STEER OPTION.

RH REAR INNER LEG ASSEMBLY (BONFIGLIOLI HUB)

DET.	QTY	PART NO.	DESCRIPTION
1	1	359565	INNER LEG WLD, AWS STS 09
2	1	470117	COTTER PIN 3/16 1 3/4 SQ CUT
3	1	470305	HOSE CLAMP, 4-HOLE
4	1	359396	RH WHL MTR SHIELD,SS STS12L 06
5	1	359404	RH WHL MTR SHIELD,STL STS12L06
6	20	473840	16MM-2.00 X 40MM SOCKET CAP SCR
7	20	473841	16MM LOCK WASHER
8	1	606291	WHL MOTOR,51C060 W/SENSR SAUER
9	1	610971	WHEEL HUB,30:1 W/BRAKE BONFIG
10	1	618467	7/16MJIC-7/16MOR ADPTR
11	2	618431	3/4 (-12) SPLIT FLANGE KIT #62
12	2	870214	BUNA ORING 1 X 1 1/4
13	10	824055	22MM-1.50 FLANGED WHEEL NUT
14	2	900138	3/8UNC X 3 1/2 HEX BOLT
15	3	473987	1/2UNC X 1 1/4BUT SKTHD SCR SS
16	2	900265	1/2UNC X 1 1/2 HEX BOLT
17	2	914004	3/8UNC HEX STOVER NUT
18	6	914008	1/2UNC HEX STOVER NUT
19	1	618812	3/4 FLANGE-1 7/16MFOR ADPTR
20	2	359102	WHL MTR SHIELD BRACE
21	1	359624	RH LWR FENDER MT WLD, STS '10
22	1	359094	HYD TUBE CLAMP KEEPER, 5.75
23	1	470379	SIDEWINDER SLEEVE,14.06 X 57"
24	1	618740	3/4 FLANGE-90-1 7/16MFOR LBO
25	1	618469	3/4MJIC-1 1/16MOR ADPTR
26	1	470378	SIDEWINDER SLEEVE,14.06 X 21"
27	1	615875	WHEEL MOTOR HYD TUBE ASSY
28	2	359367	BUSHING, CROP SHIELD, STS 05
29	3	473988	1/2UNC HEX NUT, NYLOC SS
30	1	618677	O-RING, -16 FACE SEAL .93ID 90D
31	1	606320	SPEED SENSOR, WHL MTR 606291
32	1	606321	SOLENOID, WHL MTR 606288/291
33	1	293848	WHL MTR JMPR HARNESS,STS16 05
34	4	900266	1/2UNC X 1 3/4 HEX BOLT

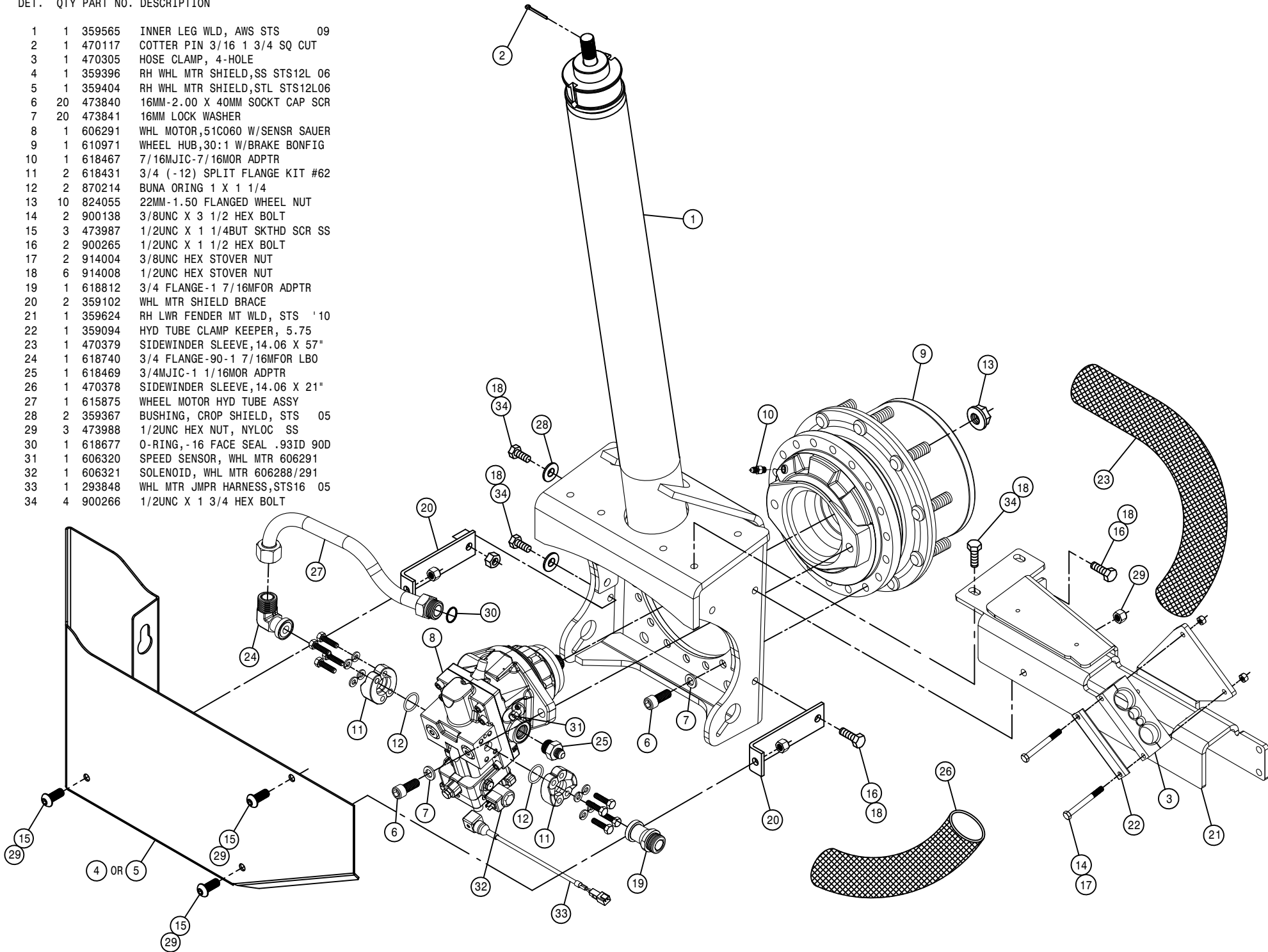

LEFT REAR OUTER LEG ASSEMBLY

DET.	QTY	PART NO.	DESCRIPTION
1	2	121029	JOURNAL BRG, 1.00 ID X 1.00 LG
2	4	121113	TOWER SLEEVE BRG (POLYGON) 05
3	2	121120	LEG SLEEVE BRG,AWS (POLYGON)09
4	1	125050	BRG CONE,1.00 ID W/FACE SEAL
5	1	125051	BRG CUP FOR 125050
6	1	125052	BRG CONE, 2.687 ID W/FACE SEAL
7	1	125053	BRG CUP FOR 125052
8	2	311058	RUBBER SPRING
9	1	311080	AIRIDE SPRING, 11.81 BASE
10	1	358832	AIRIDE SPRING CTRL VALVE 98
11	1	359619	HOSE SUPPORT,FRT STS 54" '10
12	1	359333	AIRBAG TOWER TOP MT WLD,STS 05
13	1	359351	LH EXTENDED HOSE SUPPORT, STS
14	1	359370	LH LEG AIR VALVE MT, STS16 05
15	1	359544	LEG HEIGHT CTRL LINK,AWS STS09
16	2	359545	TRUNION MT BOLT, AWS STS 09
17	1	359546	STRG CYL BOLT, AWS STS 09
18	1	359547	TOP TRUNION MT WLD, AWS STS 09
19	1	359548	BTM TRUNION MT WLD, AWS STS 09
20	1	359593	STRG ARM CLAMP WLD,STS '10
21	2	900064	5/16UNC X 3/4 HEX BOLT
22	1	359557	LH AIR BAG LWR PLT WLD,AWS STS
23	2	359563	NITRO TOWER WLD, AWS STS 09
24	1	359568	OUTER LEG WLDMT,98D AWS STS 09
25	3	470117	COTTER PIN 3/16 1 3/4 SQ CUT
26	2	470447	KEY, .50 SQ X 1.69 LG
27	5	471005	GREASE ZERK, 1/4 28 X 1/2
28	2	914002	5/16UNC HEX STOVER NUT
29	1	472328	1"-12 HEX JAM NUT
30	2	472337	5/8 X 3" SOCKET HD CAP SCR
31	1	473975	ROD END,1.00 BORE,1-12 RH MALE
32	1	483018	1" EXTERNAL TOOTH LOCK WASHER
33	2	520164	CUSH CLAMP,9/16D-3/4W-.531MT
34	1	601473	HOSE, 1/4 X 18 AIR
35	2	618115	9/16MJIC-90-3/4MOR LBO
36	1	621603	HYD CYL,2.50 X 8.81 W/SENSOR
37	1	621604	REPAIR KIT, HYD CYL 621602/603
38	8	629537	187RRHOZ SNAP RING
39	2	629538	4.5 SPIROLOX RING
40	4	629620	SEAL, 1.500 ROD DIA
41	2	629621	SEAL, 4.500 ROD DIA
42	2	711036	1/8MNPT-1/4 NYL TUBE FTG
43	1	711040	1/4MNPT-90-1/4 NYL TUBE LBO
44	2	900002	1/4UNC X 3/4 HEX BOLT
45	4	900265	1/2UNC X 1 1/2 HEX BOLT
46	4	900267	1/2UNC X 2" HEX BOLT
47	4	900268	1/2UNC X 2 1/2 HEX BOLT
48	4	900269	1/2UNC X 2 3/4 HEX BOLT
49	1	910008	1/2UNC HEX NUT
50	1	910013	3/4UNF HEX NUT
51	1	910020	1-8 HEX SLOTTED NUT
52	1	910021	1-14 SLOT JAM NUT
53	2	914000	1/4UNC HEX STOVER NUT
54	12	914008	1/2UNC HEX STOVER NUT
55	2	910102	3/4UNC SLOT HEX NUT, GR8
56	1	920008	1" SAE FLAT WASHER
57	1	920504	1/2 LOCK WASHER
58	1	920506	3/4 LOCK WASHER
59	2	473841	16MM LOCK WASHER
60	1	601476	HOSE, 1/4 X 120 AIR
61	1	470311	SIDEWINDER SLEEVE,14.06 X 60"
62	1	470305	HOSE CLAMP, 4-HOLE
63	1	359094	HYD TUBE CLAMP KEEPER, 5.75
64	3	342917	TREAD ADJ PLATE, STEEL, THD
65	4	342719	TRD ADJ BRONZE BEARING,THD-GRV
66	16	900128	3/8UNC X 3/4 HEX BOLT
67	2	900138	3/8UNC X 3 1/2 HEX BOLT
68	2	914004	3/8UNC HEX STOVER NUT
69	1	291919	INDUCTIVE SENSOR
70	1	291994	SENSOR HARNESS,MICRO-DEUTSCH
71	1	359555	SENSOR BRKT, AWS STS 09
72	2	470122	1/4UNC X 1/2 FLANGE HEX BOLT
73	1	293827	SENSOR W/DEUTSCH ASSY STS 05
74	4	483048	3/4 REG FLAT WASH,THRU-HARD
75	1	359086	REAR TIE ROD SHAFT WLD
76	1	749322	STEERING TUBE CLAMP & BOLT ASSY
77	1	359089	TIE ROD STUD WLD
78	1	359093	LH SENSOR REFLECTOR
79	1	342856	TREAD SENSOR MT
80	1	359632	OUTER LEG WLDMT,96D AWS STS'11

NOTE: (*) FOR TREAD ADJUST OPTION REPLACE ITEM 64 WITH THREE OF ITEM 65.
 (**) ITEMS ARE FOR ALL WHEEL STEER OPTION.

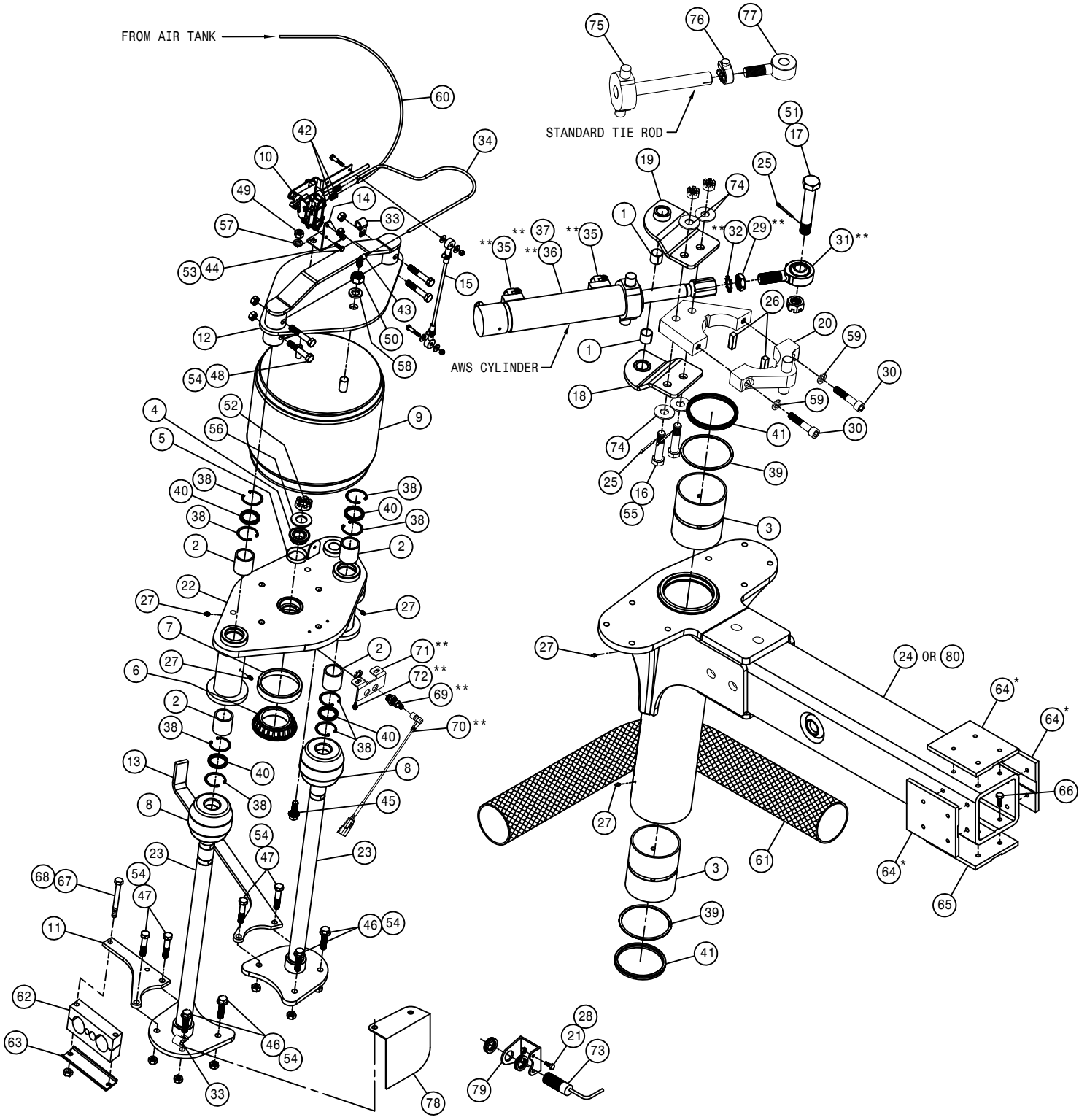

LH REAR INNER LEG ASSEMBLY (BONFIGLIOLI HUB)

DET. QTY PART NO. DESCRIPTION

1	1	359565	INNER LEG WLD, AWS STS	09
2	1	470117	COTTER PIN 3/16 1 3/4 SQ CUT	
3	1	470305	HOSE CLAMP, 4-HOLE	
4	1	359397	LH WHL MTR SHIELD,SS STS12L 06	
5	1	359405	LH WHL MTR SHIELD,STL STS12L06	
6	20	473840	16MM-2.00 X 40MM SOCKT CAP SCR	
7	20	473841	16MM LOCK WASHER	
8	1	606291	WHL MOTOR,51C060 W/SENSR SAUER	
9	1	610971	WHEEL HUB,30:1 W/BRAKE BONFIG	
10	1	618740	3/4 FLANGE-90-1 7/16MFOR LBO	
11	2	618431	3/4 (-12) SPLIT FLANGE KIT #62	
12	2	870214	BUNA ORING 1 X 1 1/4	
13	10	824055	22MM-1.50 FLANGED WHEEL NUT	
14	2	900138	3/8UNC X 3 1/2 HEX BOLT	
15	3	473987	1/2UNC X 1 1/4BUT SKTHD SCR SS	
16	2	900265	1/2UNC X 1 1/2 HEX BOLT	
17	2	914004	3/8UNC HEX STOVER NUT	
18	6	914008	1/2UNC HEX STOVER NUT	
19	1	618812	3/4 FLANGE-1 7/16MFOR ADPTR	
20	2	359102	WHL MTR SHIELD BRACE	
21	1	359625	LH LWR FENDER MT WLD, STS '10	
22	1	359094	HYD TUBE CLAMP KEEPER, 5.75	
23	1	470378	SIDEWINDER SLEEVE,14.06 X 21"	
24	1	470379	SIDEWINDER SLEEVE,14.06 X 57"	
25	1	615875	WHEEL MOTOR HYD TUBE ASSY	
26	1	618469	3/4MJIC-1 1/16MOR ADPTR	
27	1	618467	7/16MJIC-7/16MOR ADPTR	
28	2	359367	BUSHING, CROP SHIELD, STS	05
29	3	473988	1/2UNC HEX NUT, NYLOC SS	
30	1	618677	O-RING, -16 FACE SEAL .93ID 90D	
31	1	606320	SPEED SENSOR, WHL MTR 606291	
32	1	606321	SOLENOID, WHL MTR 606288/291	
33	1	293848	WHL MTR JMPR HARNESS,STS16	05
34	4	900266	1/2UNC X 1 3/4 HEX BOLT	

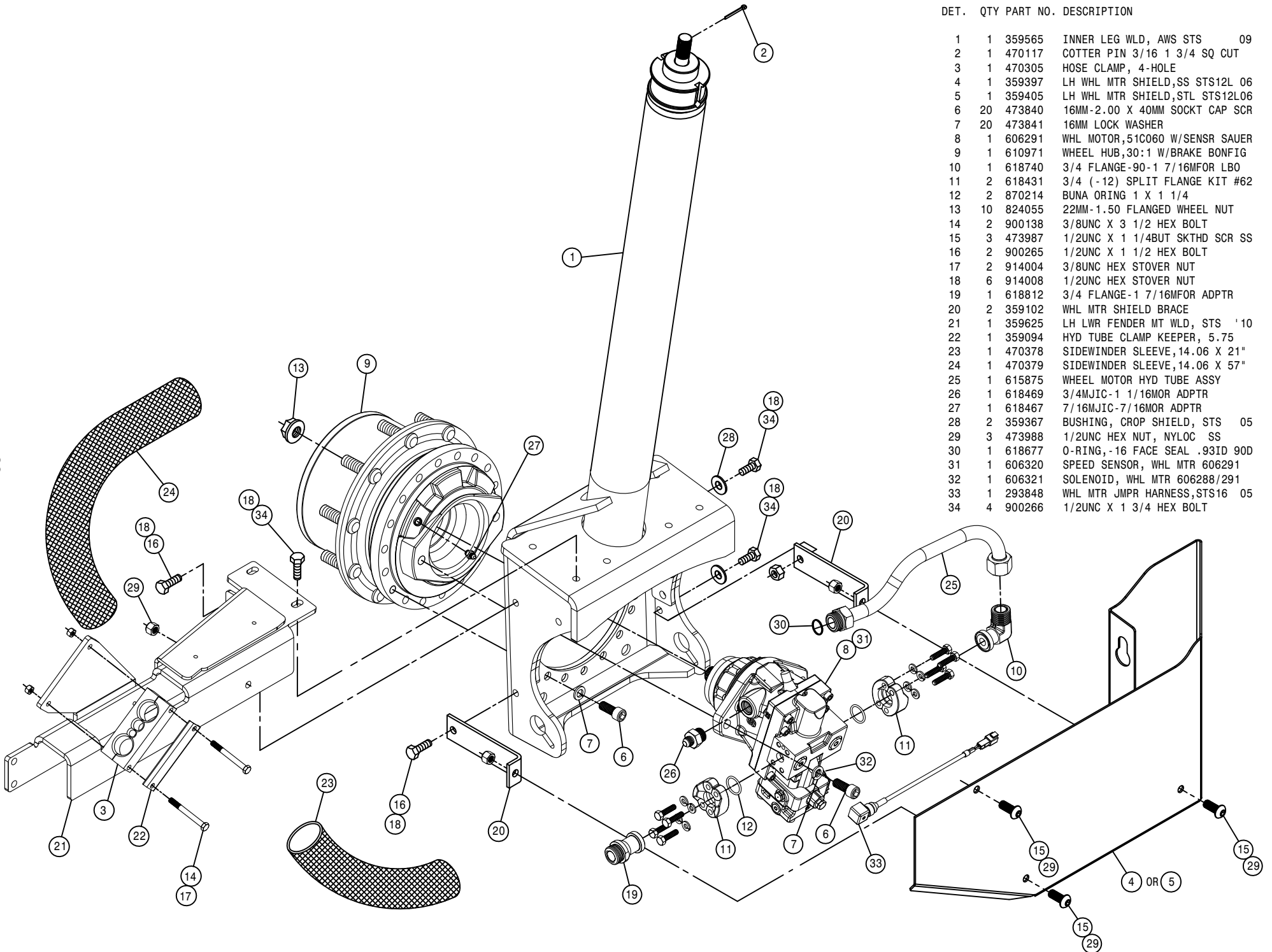

FRONT TREAD ADJUST ASSEMBLY

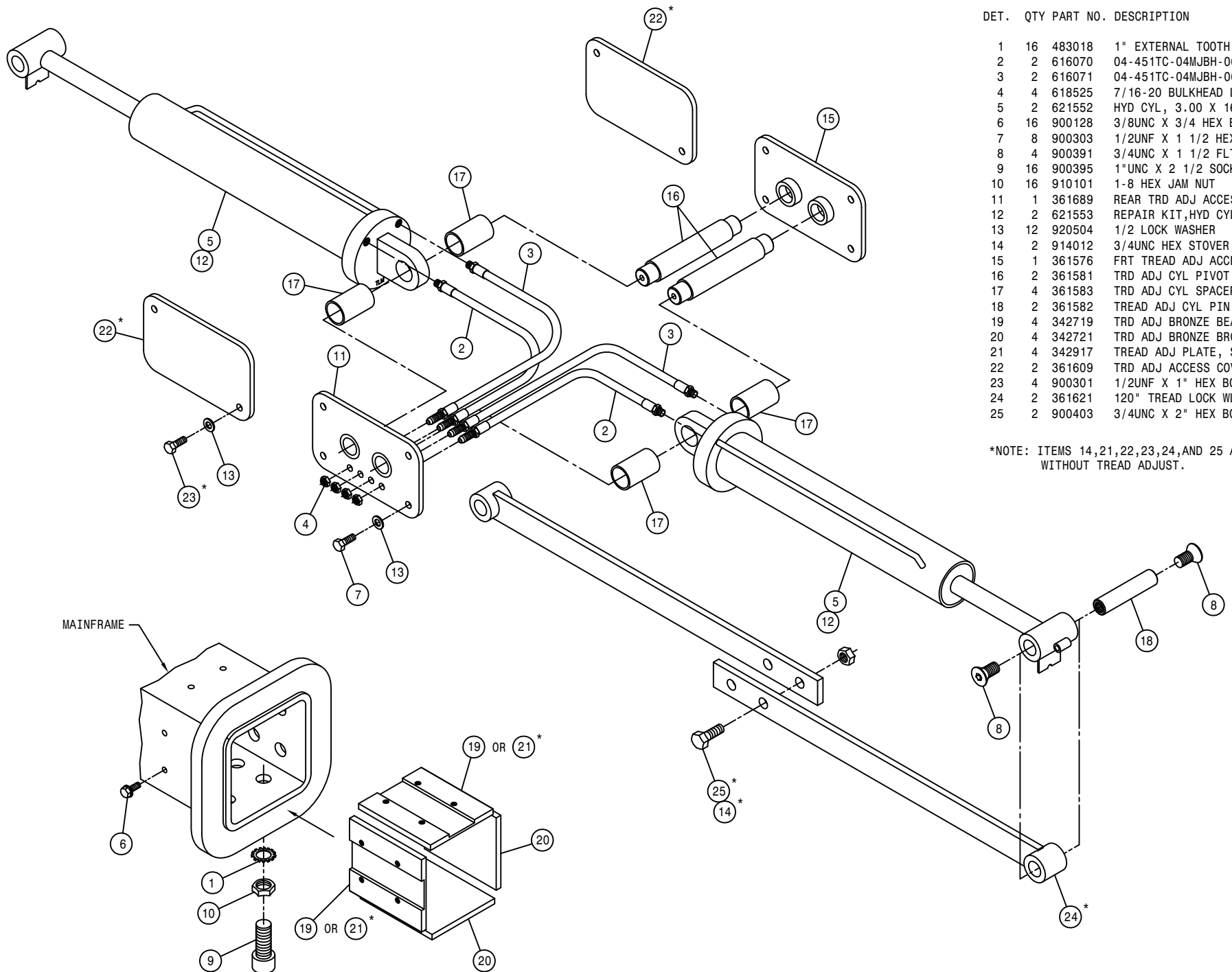

DET.	QTY	PART NO.	DESCRIPTION
1	16	483018	1" EXTERNAL TOOTH LOCK WASHER
2	2	616070	04-451TC-04MJBH-06MOR-11.00H/A
3	2	616071	04-451TC-04MJBH-06MOR-13.00H/A
4	4	618525	7/16-20 BULKHEAD LOCKNUT
5	2	621552	HYD CYL, 3.00 X 16.00 X 1.375
6	16	900128	3/8UNC X 3/4 HEX BOLT
7	8	900303	1/2UNF X 1 1/2 HEX BOLT
8	4	900391	3/4UNC X 1 1/2 FLT SOC CAP SCR
9	16	900395	1"UNC X 2 1/2 SOCKET CAP SCR
10	16	910101	1-8 HEX JAM NUT
11	1	361689	REAR TRD ADJ ACCESS PLT WLD 04
12	2	621553	REPAIR KIT, HYD CYL 621552
13	12	920504	1/2 LOCK WASHER
14	2	914012	3/4UNC HEX STOVER NUT
15	1	361576	FRT TREAD ADJ ACCESS PLT WLD
16	2	361581	TRD ADJ CYL PIVOT PIN, M/F
17	4	361583	TRD ADJ CYL SPACER, M/F
18	2	361582	TREAD ADJ CYL PIN, OUTER LEG
19	4	342719	TRD ADJ BRONZE BEARING, THD-GRV
20	4	342721	TRD ADJ BRONZE BRG W/DIMPLES
21	4	342917	TREAD ADJ PLATE, STEEL, THD
22	2	361609	TRD ADJ ACCESS COVER, M/F STS10
23	4	900301	1/2UNF X 1" HEX BOLT
24	2	361621	120" TREAD LOCK WLD, STS10 03
25	2	900403	3/4UNC X 2" HEX BOLT

*NOTE: ITEMS 14, 21, 22, 23, 24, AND 25 ARE USED WITHOUT TREAD ADJUST.

REAR TREAD ADJUST ASSEMBLY

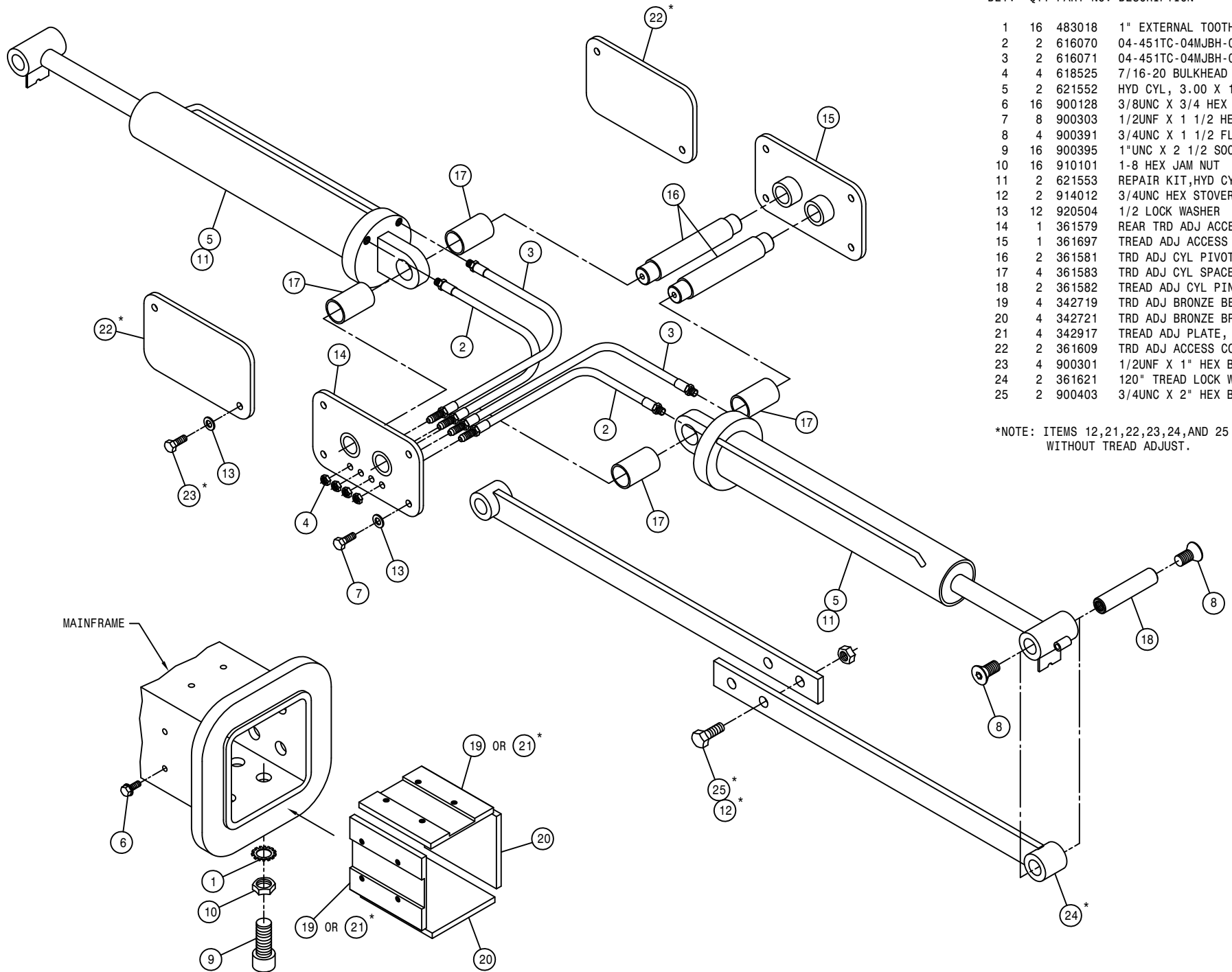

DET.	QTY	PART NO.	DESCRIPTION
1	16	483018	1" EXTERNAL TOOTH LOCK WASHER
2	2	616070	04-451TC-04MJBH-06MOR-11.00H/A
3	2	616071	04-451TC-04MJBH-06MOR-13.00H/A
4	4	618525	7/16-20 BULKHEAD LOCKNUT
5	2	621552	HYD CYL, 3.00 X 16.00 X 1.375
6	16	900128	3/8UNC X 3/4 HEX BOLT
7	8	900303	1/2UNF X 1 1/2 HEX BOLT
8	4	900391	3/4UNC X 1 1/2 FLT SOC CAP SCR
9	16	900395	1"UNC X 2 1/2 SOCKET CAP SCR
10	16	910101	1-8 HEX JAM NUT
11	2	621553	REPAIR KIT, HYD CYL 621552
12	2	914012	3/4UNC HEX STOVER NUT
13	12	920504	1/2 LOCK WASHER
14	1	361579	REAR TRD ADJ ACCESS PLT WLD 00
15	1	361697	TREAD ADJ ACCESS PLT WLD 07
16	2	361581	TRD ADJ CYL PIVOT PIN, M/F
17	4	361583	TRD ADJ CYL SPACER, M/F
18	2	361582	TREAD ADJ CYL PIN, OUTER LEG
19	4	342719	TRD ADJ BRONZE BEARING, THD-GRV
20	4	342721	TRD ADJ BRONZE BRG W/DIMPLES
21	4	342917	TREAD ADJ PLATE, STEEL, THD
22	2	361609	TRD ADJ ACCESS COVER, M/F STS10
23	4	900301	1/2UNF X 1" HEX BOLT
24	2	361621	120" TREAD LOCK WLD, STS10 03
25	2	900403	3/4UNC X 2" HEX BOLT

*NOTE: ITEMS 12, 21, 22, 23, 24, AND 25 ARE USED WITHOUT TREAD ADJUST.

MAINFRAME

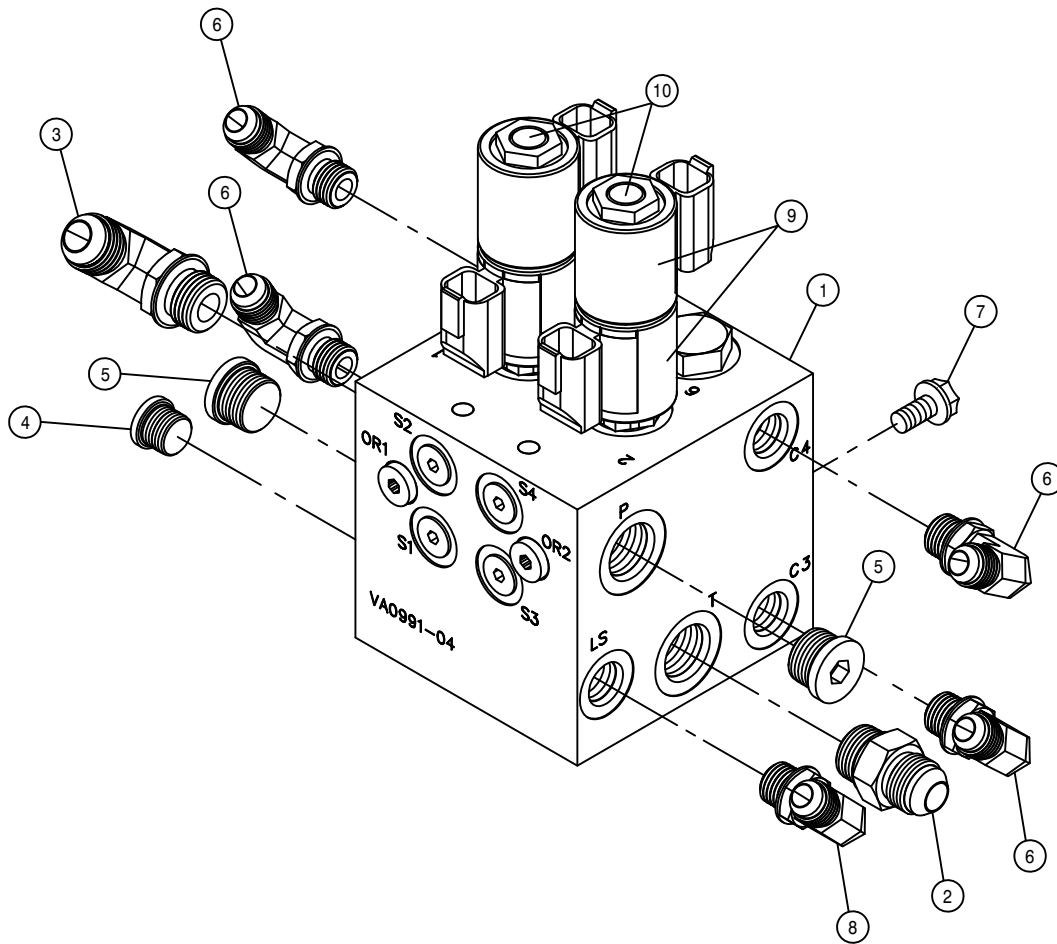

FRONT TREAD ADJUST VALVE ASSEMBLY

DET.	QTY	PART NO.	DESCRIPTION	
1	1	606249	MANIFOLD, TRD ADJ	PWRSYS
2	1	611125	3/4MJIC-3/4MOR ADPTR	
3	1	618241	3/4MJIC-90-3/4MOR LBO	
4	1	618754	9/16MOR PLUG, HEX SOCKET	
5	2	618755	3/4MOR PLUG, HEX SOCKET	
6	4	618119	9/16MJIC-90-9/16MOR LBO	
7	2	900064	5/16UNC X 3/4 HEX BOLT	
8	1	618499	7/16MJIC-90-9/16MOR LBO	
9	4	606266	#8 COIL W/DEUTSCH FOR 606210	
10	2	606358	CARTRIDGE SP08-47D,PROP,3POS	

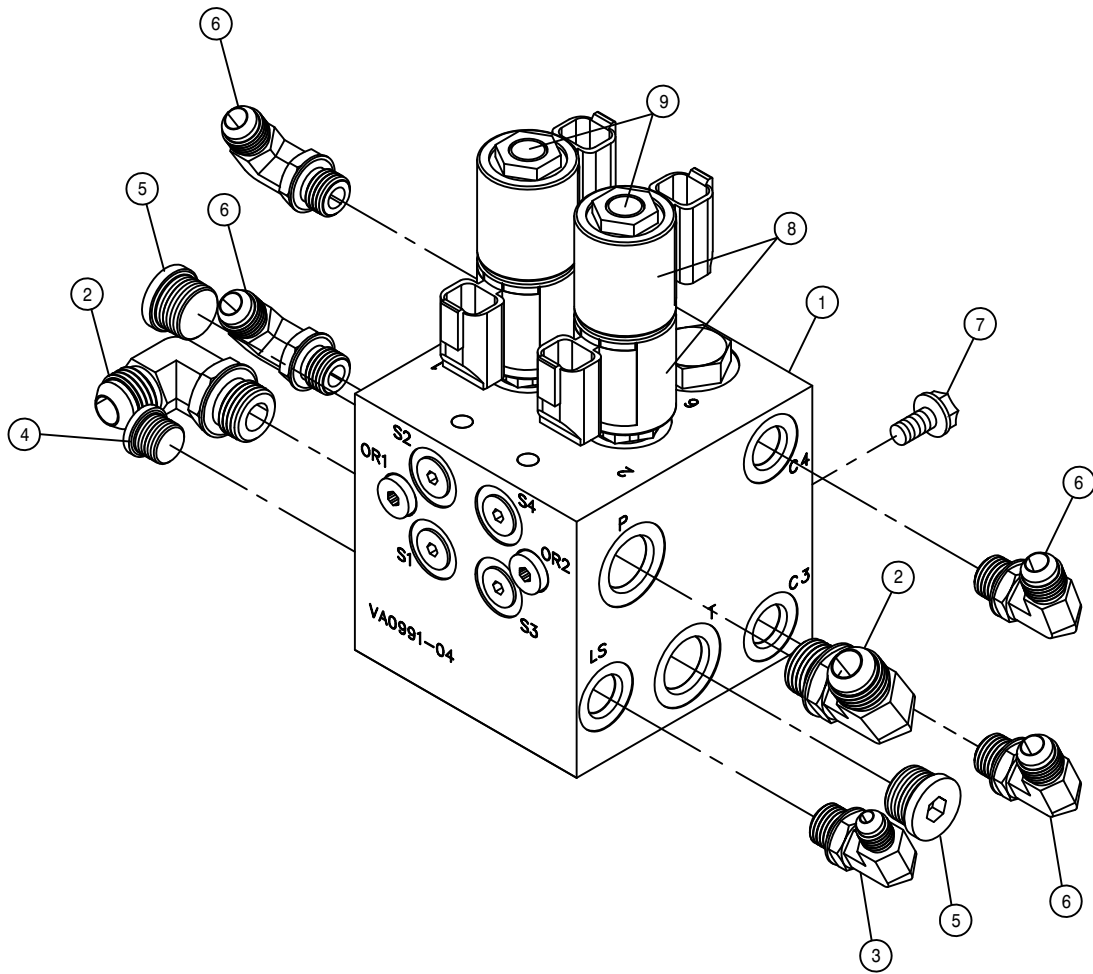

REAR TREAD ADJUST VALVE ASSEMBLY

DET.	QTY	PART NO.	DESCRIPTION	PWRSYS
	1	606249	MANIFOLD, TRD ADJ	PWRSYS
	2	618241	3/4MJIC-90-3/4MOR LBO	
	3	618499	7/16MJIC-90-9/16MOR LBO	
	4	618754	9/16MOR PLUG, HEX SOCKET	
	5	618755	3/4MOR PLUG, HEX SOCKET	
	6	618119	9/16MJIC-90-9/16MOR LBO	
	7	900064	5/16UNC X 3/4 HEX BOLT	
	8	606266	#8 COIL W/DEUTSCH	
	9	606358	CARTRIDGE SP08-47D, PROP, 3POS	

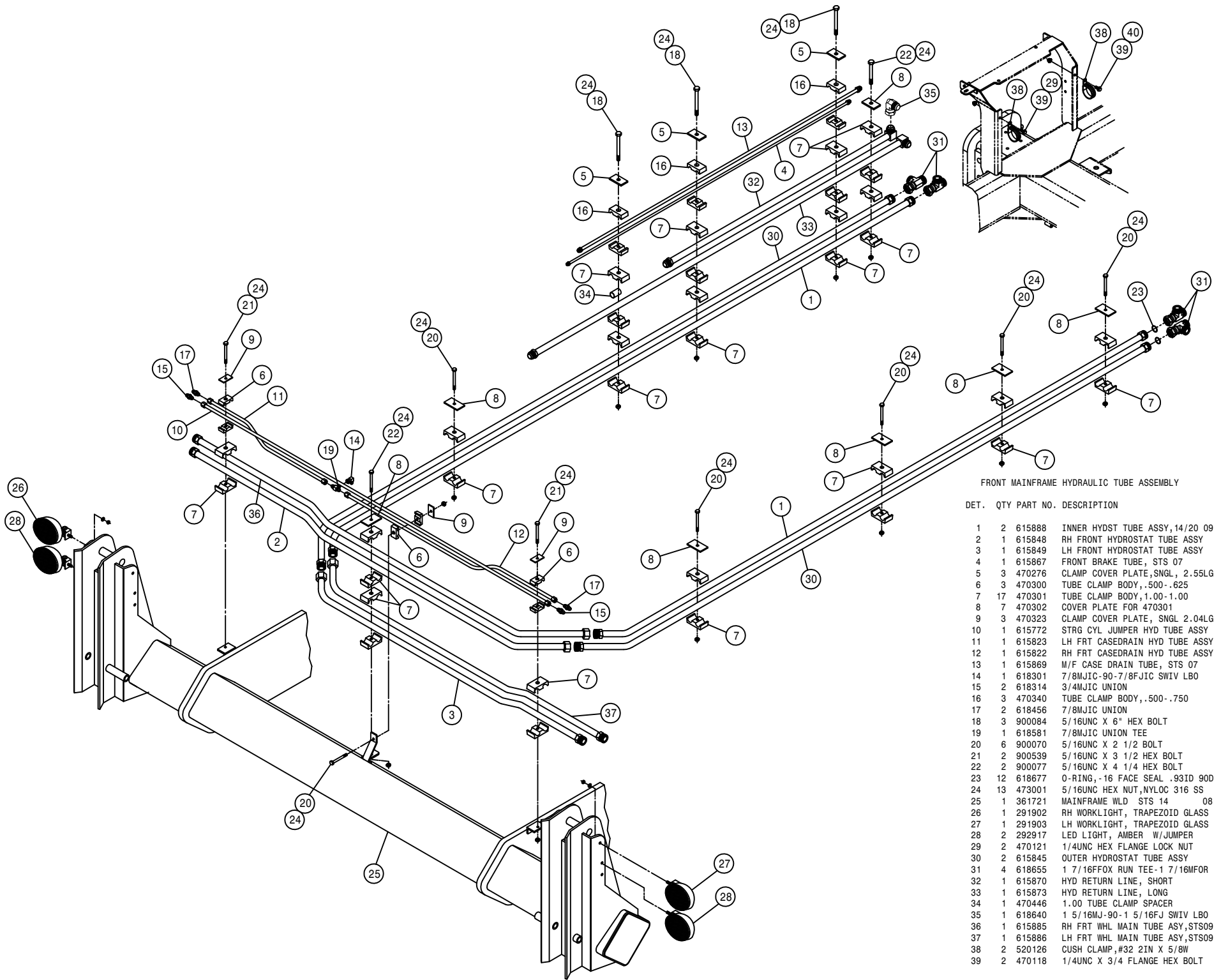

FRONT MAINFRAME HYDRAULIC TUBE ASSEMBLY

DET. QTY PART NO. DESCRIPTION

DET.	QTY	PART NO.	DESCRIPTION
1	2	615888	INNER HYDST TUBE ASSY, 14/20 09
2	1	615848	RH FRONT HYDROSTAT TUBE ASSY
3	1	615849	LH FRONT HYDROSTAT TUBE ASSY
4	1	615867	FRONT BRAKE TUBE, STS 07
5	3	470276	CLAMP COVER PLATE, SNGL, 2.55LG
6	3	470300	TUBE CLAMP BODY, .500-.625
7	17	470301	TUBE CLAMP BODY, 1.00-1.00
8	7	470302	COVER PLATE FOR 470301
9	3	470323	CLAMP COVER PLATE, SNGL 2.04LG
10	1	615772	STRG CYL JUMPER HYD TUBE ASSY
11	1	615823	LH FRT CASEDRAIN HYD TUBE ASSY
12	1	615822	RH FRT CASEDRAIN HYD TUBE ASSY
13	1	615869	M/F CASE DRAIN TUBE, STS 07
14	1	618301	7/8MJIC-90-7/8FJIC SWIV LBO
15	2	618314	3/4MJIC UNION
16	3	470340	TUBE CLAMP BODY, .500-.750
17	2	618456	7/8MJIC UNION
18	3	900084	5/16UNC X 6" HEX BOLT
19	1	618581	7/8MJIC UNION TEE
20	6	900070	5/16UNC X 2 1/2 BOLT
21	2	900539	5/16UNC X 3 1/2 HEX BOLT
22	2	900077	5/16UNC X 4 1/4 HEX BOLT
23	12	618677	O-RING, -16 FACE SEAL .93ID 90D
24	13	473001	5/16UNC HEX NUT, NYLOC 316 SS
25	1	361721	MAINFRAME WLD STS 14 08
26	1	291902	RH WORKLIGHT, TRAPEZOID GLASS
27	1	291903	LH WORKLIGHT, TRAPEZOID GLASS
28	2	292917	LED LIGHT, AMBER W/JUMPER
29	2	470121	1/4UNC HEX FLANGE LOCK NUT
30	2	615845	OUTER HYDROSTAT TUBE ASSY
31	4	618655	1 7/16FFOX RUN TEE-1 7/16MFOR
32	1	615870	HYD RETURN LINE, SHORT
33	1	615873	HYD RETURN LINE, LONG
34	1	470446	1.00 TUBE CLAMP SPACER
35	1	618640	1 5/16MJ-90-1 5/16FJ SWIV LBO
36	1	615885	RH FRT WHL MAIN TUBE ASY, STS09
37	1	615886	LH FRT WHL MAIN TUBE ASY, STS09
38	2	520126	CUSH CLAMP, #32 2IN X 5/8W
39	2	470118	1/4UNC X 3/4 FLANGE HEX BOLT

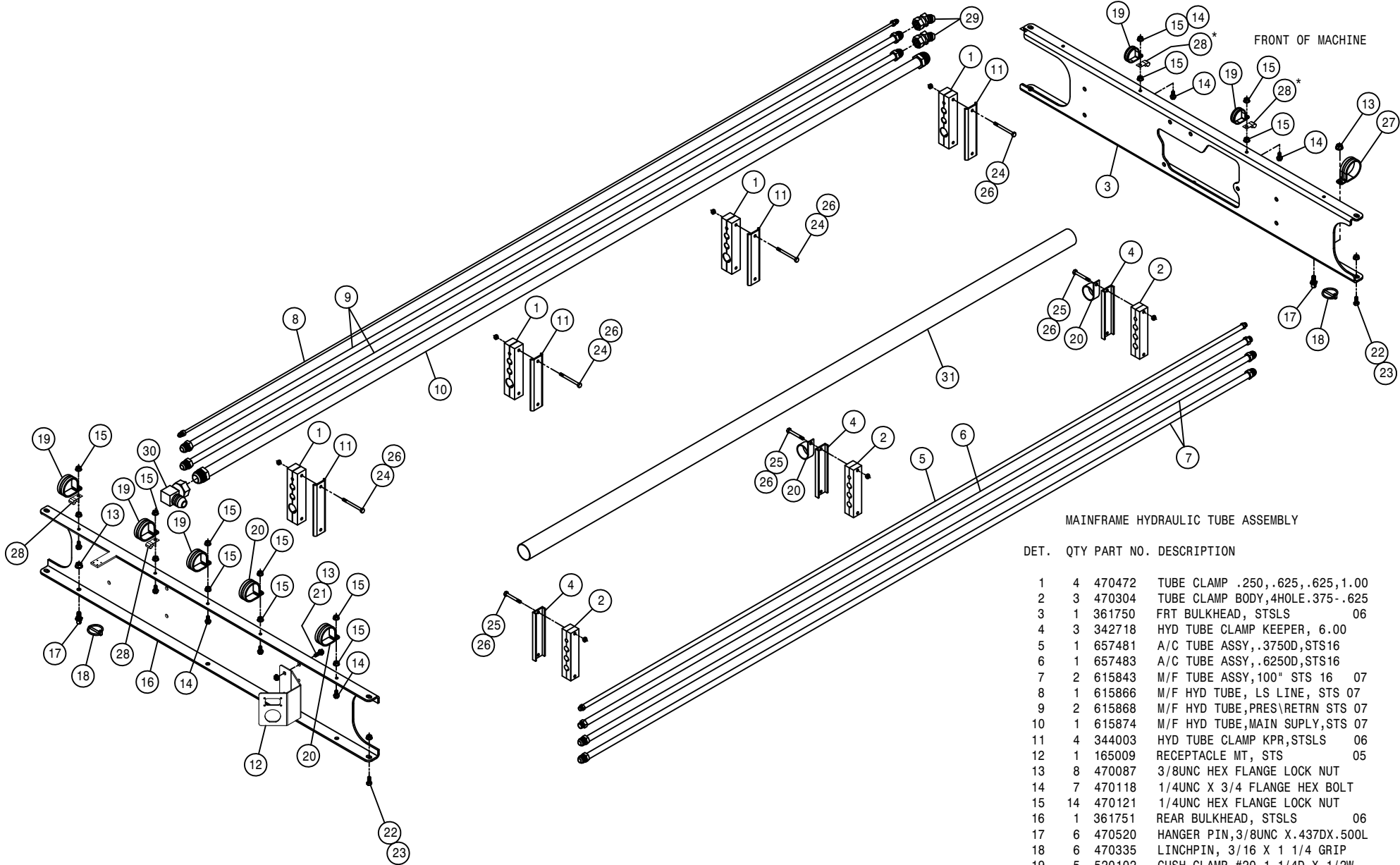

MAINFRAME HYDRAULIC TUBE ASSEMBLY

DET. QTY PART NO. DESCRIPTION

DET.	QTY	PART NO.	DESCRIPTION
1	4	470472	TUBE CLAMP .250, .625, .625, 1.00
2	3	470304	TUBE CLAMP BODY, 4HOLE .375- .625
3	1	361750	FRT BULKHEAD, STSLS 06
4	3	342718	HYD TUBE CLAMP KEEPER, 6.00
5	1	657481	A/C TUBE ASSY, .3750D, STS16
6	1	657483	A/C TUBE ASSY, .6250D, STS16
7	2	615843	M/F TUBE ASSY, 100" STS 16 07
8	1	615866	M/F HYD TUBE, LS LINE, STS 07
9	2	615868	M/F HYD TUBE, PRES\RETRN STS 07
10	1	615874	M/F HYD TUBE, MAIN SUPPLY, STS 07
11	4	344003	HYD TUBE CLAMP KPR, STSLS 06
12	1	165009	RECEPTACLE MT, STS 05
13	8	470087	3/8UNC HEX FLANGE LOCK NUT
14	7	470118	1/4UNC X 3/4 FLANGE HEX BOLT
15	14	470121	1/4UNC HEX FLANGE LOCK NUT
16	1	361751	REAR BULKHEAD, STSLS 06
17	6	470520	HANGER PIN, 3/8UNC X .437DX .500L
18	6	470335	LINCHPIN, 3/16 X 1 1/4 GRIP
19	5	520102	CUSH CLAMP, #20 1 1/4D X 1/2W
20	4	520126	CUSH CLAMP, #32 2IN X 5/8W
21	2	900128	3/8UNC X 3/4 HEX BOLT
22	8	900129	3/8UNC X 1" SERR FLANGE BOLT
23	8	910004	3/8UNC HEX NUT
24	8	900008	1/4UNC X 2 1/2 HEX BOLT
25	6	900007	1/4UNC X 2" HEX BOLT
26	14	470089	1/4UNC HEX NYLOC NUT, 316 SS
27	1	520161	CUSH CLAMP, #32 2"D-3/4W LOOP
28	4	520128	CUSH J CLAMP, #9 9/16D X 3/4W
29	2	618628	7/8MJIC-45-7/8FJIC SWIV LBO
30	1	618640	1 5/16MJ-90-1 5/16FJ SWIV LBO
31	1	470403	SIDEWINDER SLEEVE, 8.50 X 106"

NOTE: ITEMS WITH (*) ARE USED WITH THE SIDE FILL OPTION.

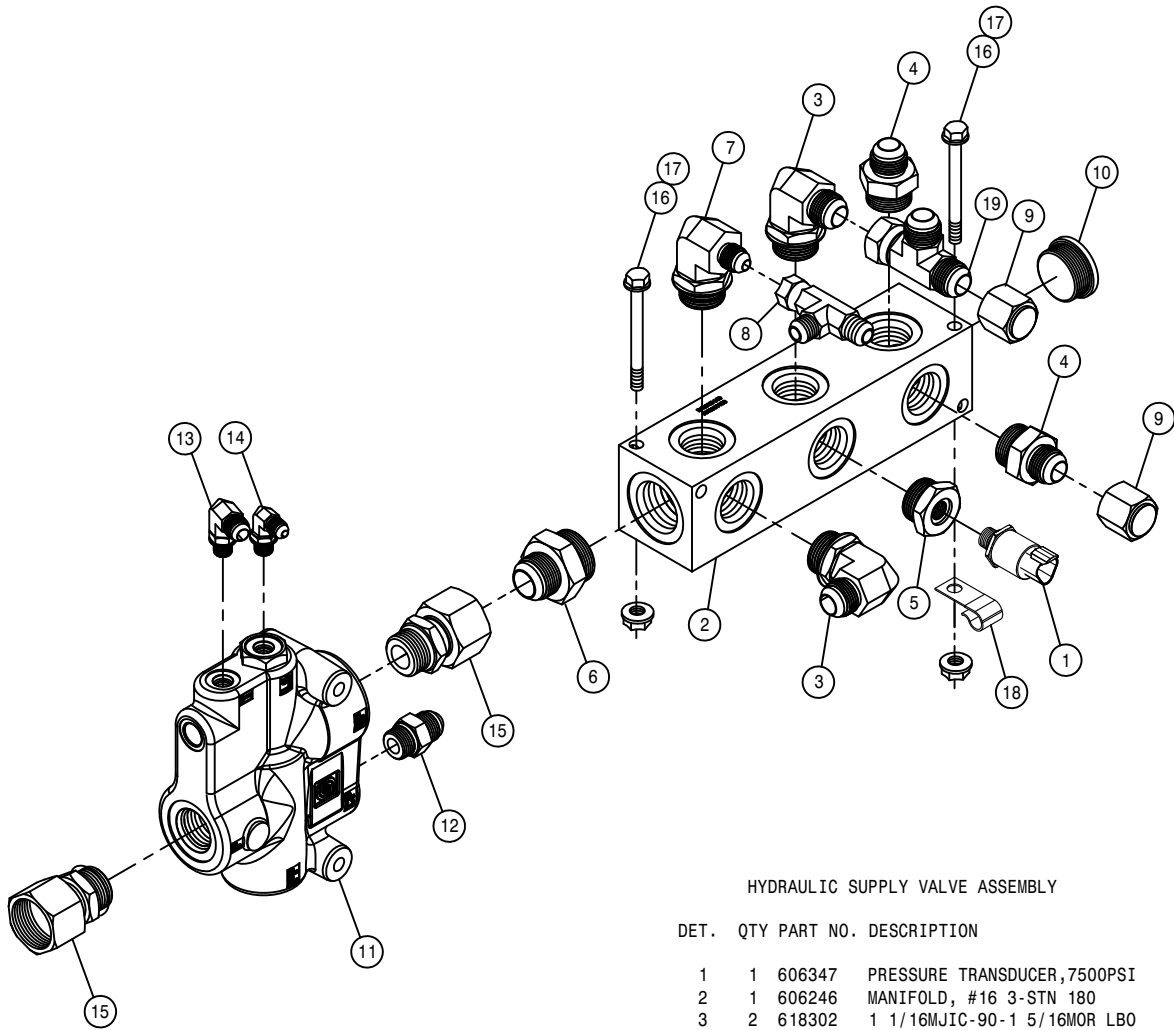

HYDRAULIC SUPPLY VALVE ASSEMBLY

DET. QTY PART NO. DESCRIPTION

DET.	QTY	PART NO.	DESCRIPTION
1	1	606347	PRESSURE TRANSDUCER,7500PSI
2	1	606246	MANIFOLD, #16 3-STN 180
3	2	618302	1 1/16MJIC-90-1 5/16MOR LBO
4	2	618308	1 1/16MJIC-1 5/16MOR ADPTR
5	1	618397	1 5/16MOR-9/16FOR ADPTR
6	1	618455	1 5/16MJIC-1 5/8MOR ADPTR
7	1	618475	3/4MJIC-90-1 5/16MOR LBO
8	1	618451	3/4FJIC SW RUN TEE-3/4MJIC
9	2	618533	1 1/16FJIC CAP NUT
10	1	618759	1 5/8MOR PLUG, HEX SOCKET
11	1	606254	FLOW DIVIDER, OLS160 SAUER
12	1	611125	3/4MJIC-3/4MOR ADPTR
13	1	618114	9/16MJIC-90-7/16MOR LBO
14	1	618473	7/16MJIC-90-7/16MOR LBO
15	2	618761	1 5/16FJX-1 1/16MOR ADPTR
16	2	900140	3/8UNC X 4" HEX BOLT
17	2	470087	3/8UNC HEX FLANGE LOCK NUT
18	1	520128	CUSH J CLAMP,#9 9/16D X 3/4W
19	1	618487	1 1/16FJ SW RUN TEE-1 1/16MJ

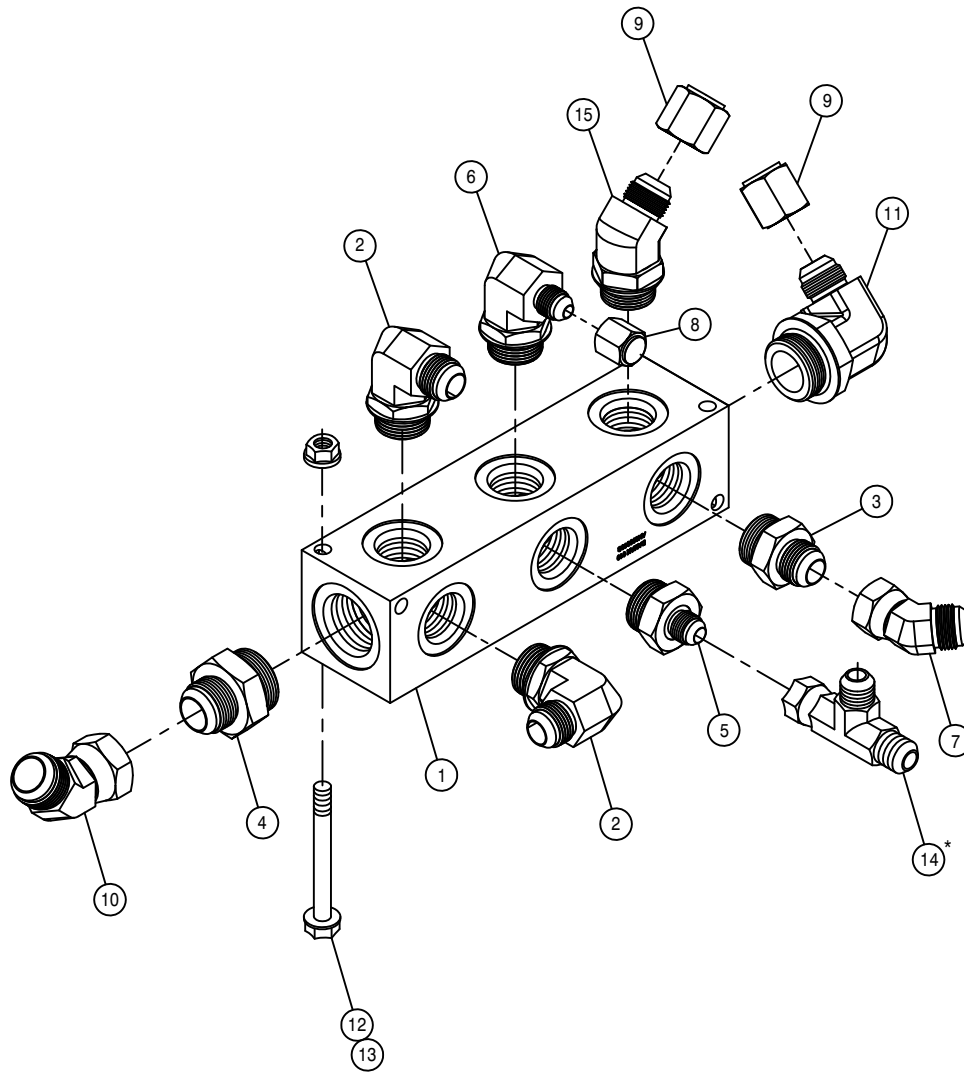

FRONT RETURN MANIFOLD ASSEMBLY

DET. QTY PART NO. DESCRIPTION

1	1	606246	MANIFOLD, #16 3-STN 180
2	2	618302	1 1/16MJIC-90-1 5/16MOR LBO
3	1	618308	1 1/16MJIC-1 5/16MOR ADPTR
4	1	618455	1 5/16MJIC-1 5/8MOR ADPTR
5	1	618470	3/4MJIC-1 5/16MOR ADPTR
6	1	618475	3/4MJIC-90-1 5/16MOR LBO
7	1	618529	1 1/16MJ-45-1 1/16FJ SWIV LBO
8	1	618532	3/4FJIC CAP NUT
9	2	618533	1 1/16FJIC CAP NUT
10	1	618630	1 5/16MJ-45-1 5/16FJ SWIV LBO
11	1	618842	1 1/16MJIC-90-1 5/8MOR LBO
12	2	470087	3/8UNC HEX FLANGE LOCK NUT
13	2	900139	3/8UNC X 3 3/4 HEX BOLT
14	1	618451	3/4FJIC SW RUN TEE-3/4MJIC
15	1	618831	1 1/16MJIC-45-1 5/16MOR LBO

NOTE: (*) IS USED WITH TREAD ADJUST OPTION OR SIDE FILL OPTION.

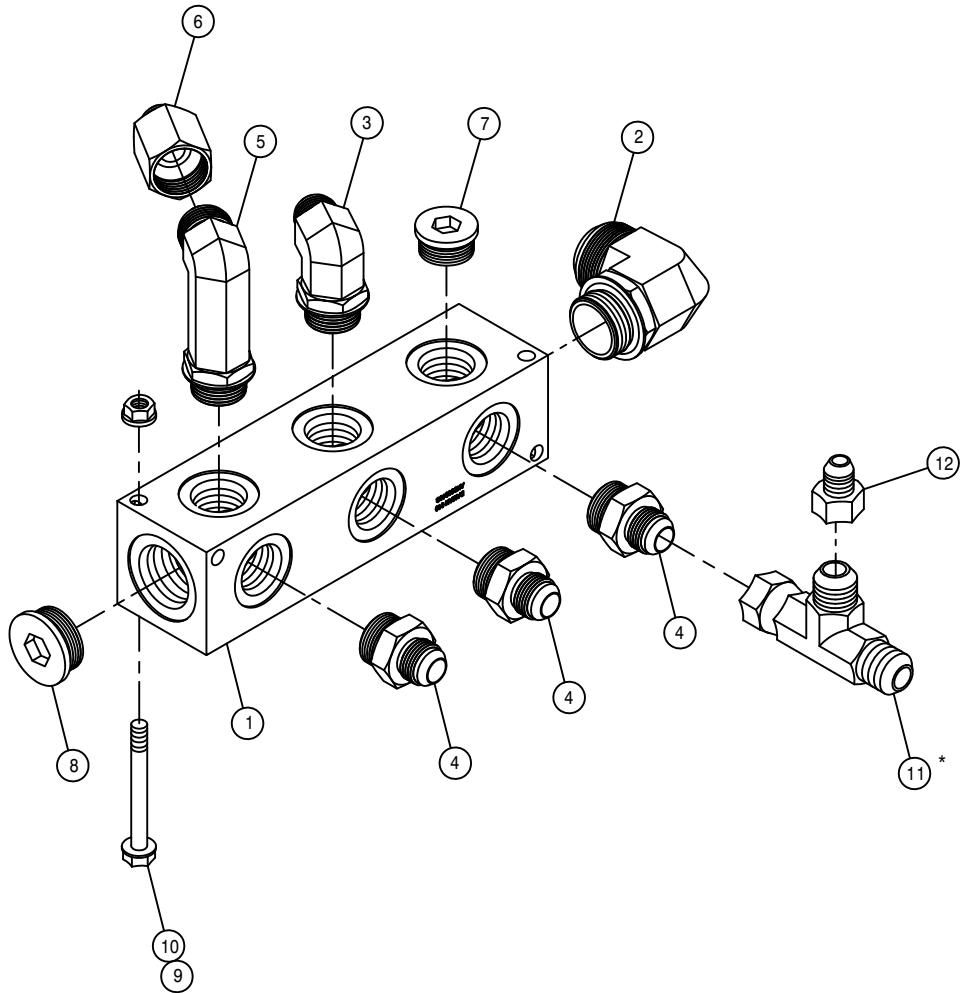

CASE DRAIN MANIFOLD ASSEMBLY

DET. QTY PART NO. DESCRIPTION

1	1	606246	MANIFOLD, #16 3-STN 180
2	1	618477	1 5/8M JIC-90-1 5/8MOR LBO
3	1	618302	1 1/16M JIC-90-1 5/16MOR LBO
4	3	618308	1 1/16M JIC-1 5/16MOR ADPTR
5	1	618463	1 5/16M JIC-90-1 5/16MOR XL LBO
6	1	618541	1 5/16F JIC-1 1/16M JIC ADPTR
7	1	618758	1 5/16 MOR PLUG, HEX SOCKET
8	1	618759	1 5/8MOR PLUG, HEX SOCKET
9	2	470087	3/8UNC HEX FLANGE LOCK NUT
10	2	900139	3/8UNC X 3/4 HEX BOLT
11	1	618487	1 1/16FJ SW RUN TEE-1 1/16MJ
12	1	618483	1 1/16F JIC-9/16M JIC ADPTR

*NOTE: USED WITH PRESSURE WASHER OPTION.

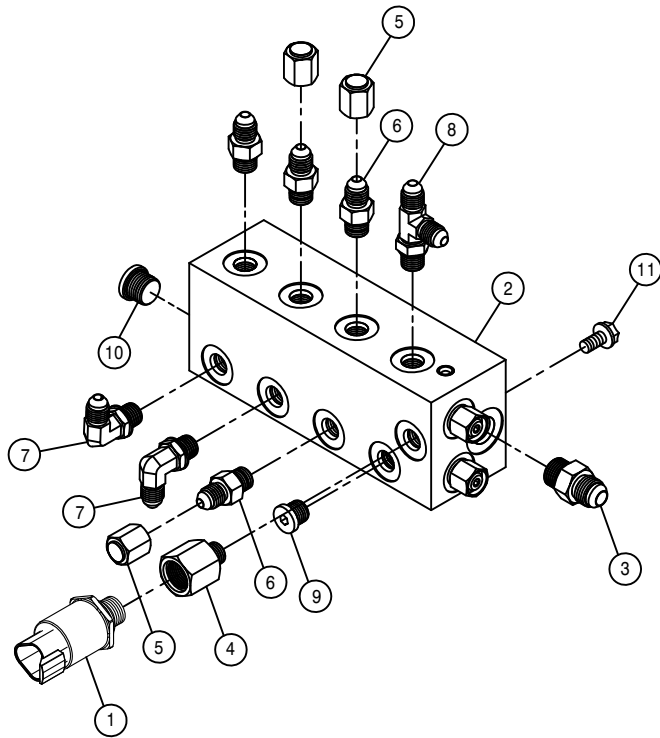

LS MANIFOLD ASSEMBLY

DET. QTY PART NO. DESCRIPTION

1	1	606347	PRESSURE TRANSDUCER,7500PSI
2	1	606247	MANIFOLD W/CHK VLV SAUER
3	1	618126	9/16MJIC-9/16MOR ADPTR
4	1	618361	7/16MOR-9/16FOR ADPTR
5	3	618363	7/16FJIC CAP NUT
6	4	618467	7/16MJIC-7/16MOR ADPTR
7	2	618473	7/16MJIC-90-7/16MOR LBO
8	1	618509	7/16MOR RUN TEE-7/16MJIC
9	1	618753	7/16MOR PLUG, HEX SOCKET
10	1	618754	9/16MOR PLUG, HEX SOCKET
11	2	900128	3/8UNC X 3/4 HEX BOLT

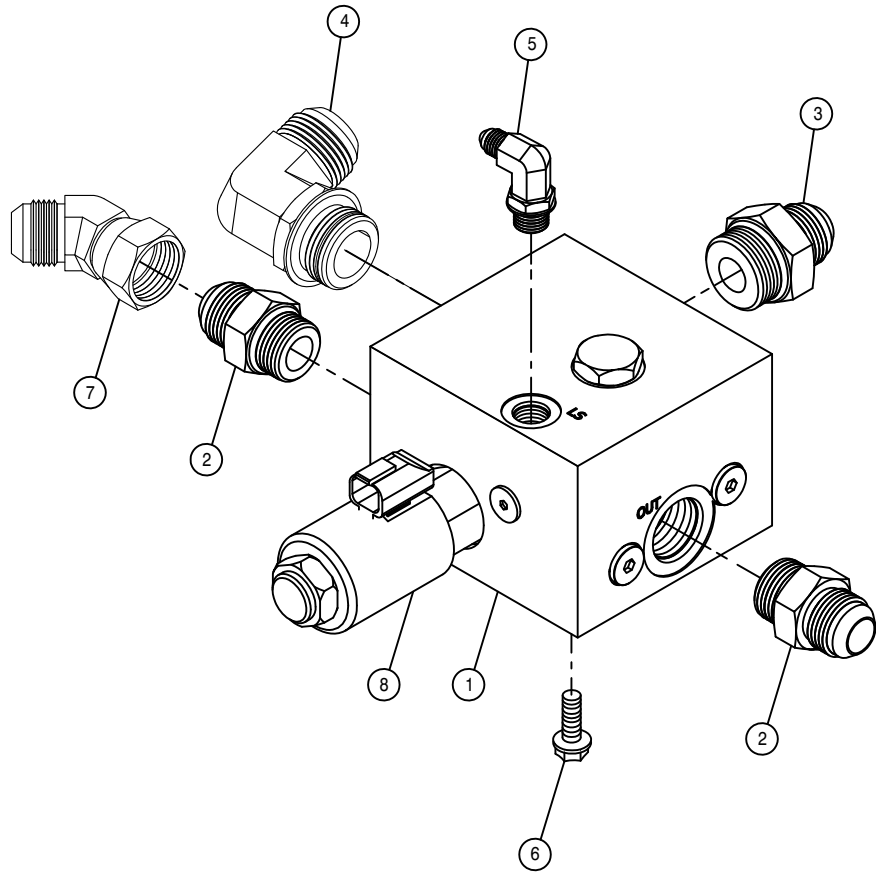

SOLUTION PUMP CONTROL VALVE ASSEMBLY

DET. QTY PART NO. DESCRIPTION

1	1	606253	CTRL VALVE,SOLU PUMP SAUER
2	2	611127	1 1/16MJIC-1 1/16MOR ADPTR
3	1	618308	1 1/16MJIC-1 5/16MOR ADPTR
4	1	618178	1 5/16MJIC-90-1 5/16MOR LBO
5	1	618499	7/16MJIC-90-9/16MOR LBO
6	4	900129	3/8UNC X 1" SERR FLANGE BOLT
7	1	618529	1 1/16MJ-45-1 1/16FJ SWIV LBO
8	1	606308	COIL FOR VLV 606253

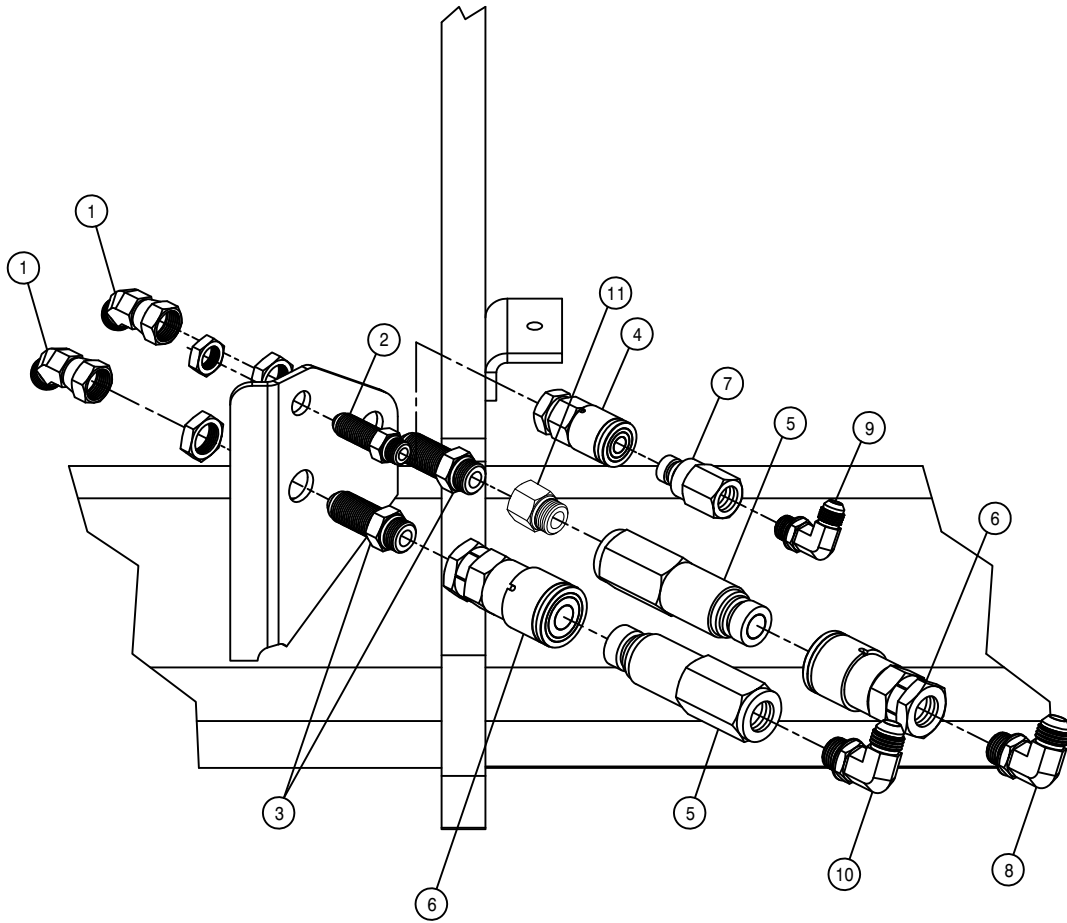

QUICK CONNECT ASSEMBLY

DET.	QTY	PART NO.	DESCRIPTION
1	2	618590	3/4MJIC-45-3/4FJIC SWIV LBO
2	1	618769	9/16MJIC-9/16MOR BLKHD ADPT
3	2	618770	3/4MJIC-3/4MOR BLKHD ADPT
4	1	618805	HYD CPLR, FEM #14,9/16FOR
5	2	618806	HYD CPLR, MALE #12,7/8FOR
6	2	618807	HYD CPLR, FEM #12,3/4FOR
7	1	618804	HYD CPLR, MALE #14,9/16FOR
8	1	618241	3/4MJIC-90-3/4MOR LBO
9	1	618119	9/16MJIC-90-9/16MOR LBO
10	1	618183	3/4MJIC-90-7/8MOR LBO
11	1	618171	7/8MOR-3/4FOR ADPTR

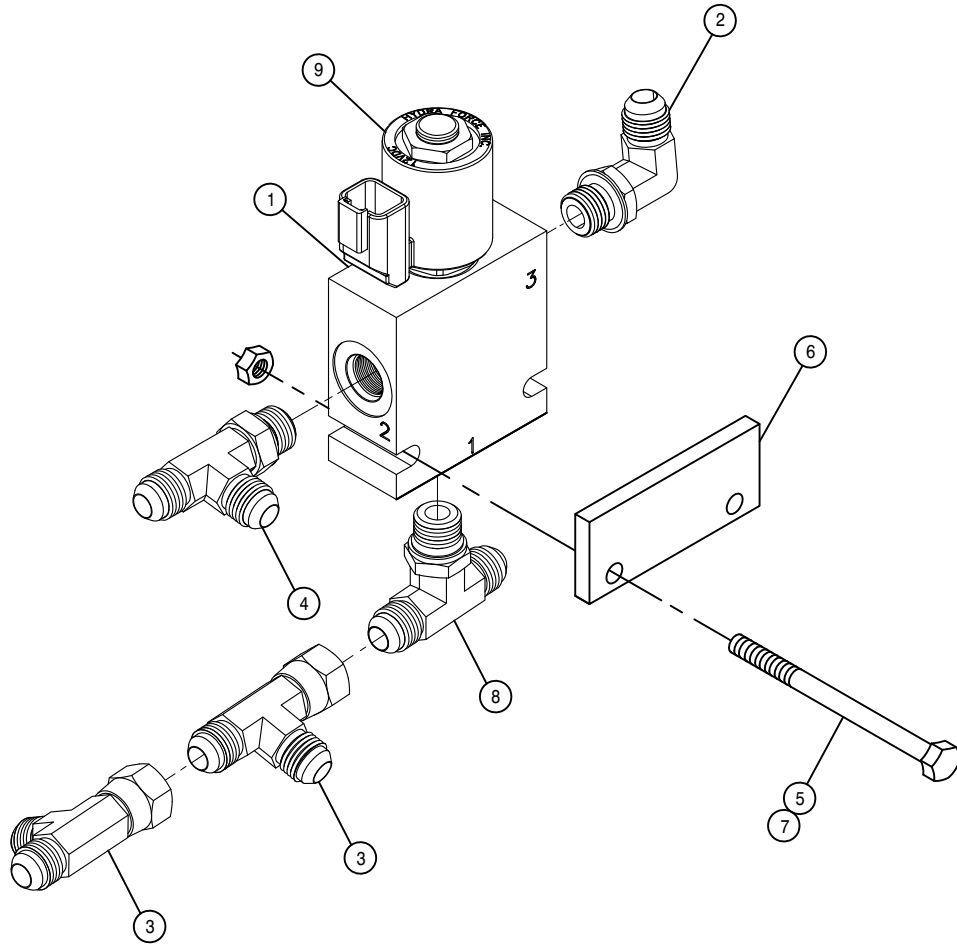

LADDER AND BRAKE VALVE ASSEMBLY

DET.	QTY	PART NO.	DESCRIPTION
1	1	606213	HYD SOLE VLV,2P-3W,9/16FOR 05
2	1	618119	9/16MJIC-90-9/16MOR LBO
3	2	618486	9/16FJIC SW RUN TEE-9/16MJIC
4	1	618444	9/16MOR RUN TEE-9/16MJIC
5	2	900007	1/4UNC X 2" HEX BOLT
6	1	342826	SOLE VLV SPACER
7	2	914000	1/4UNC HEX STOVER NUT
8	1	618629	9/16MOR BRANCH TEE-9/16MJIC
9	1	606266	#8 COIL W/DEUTSCH

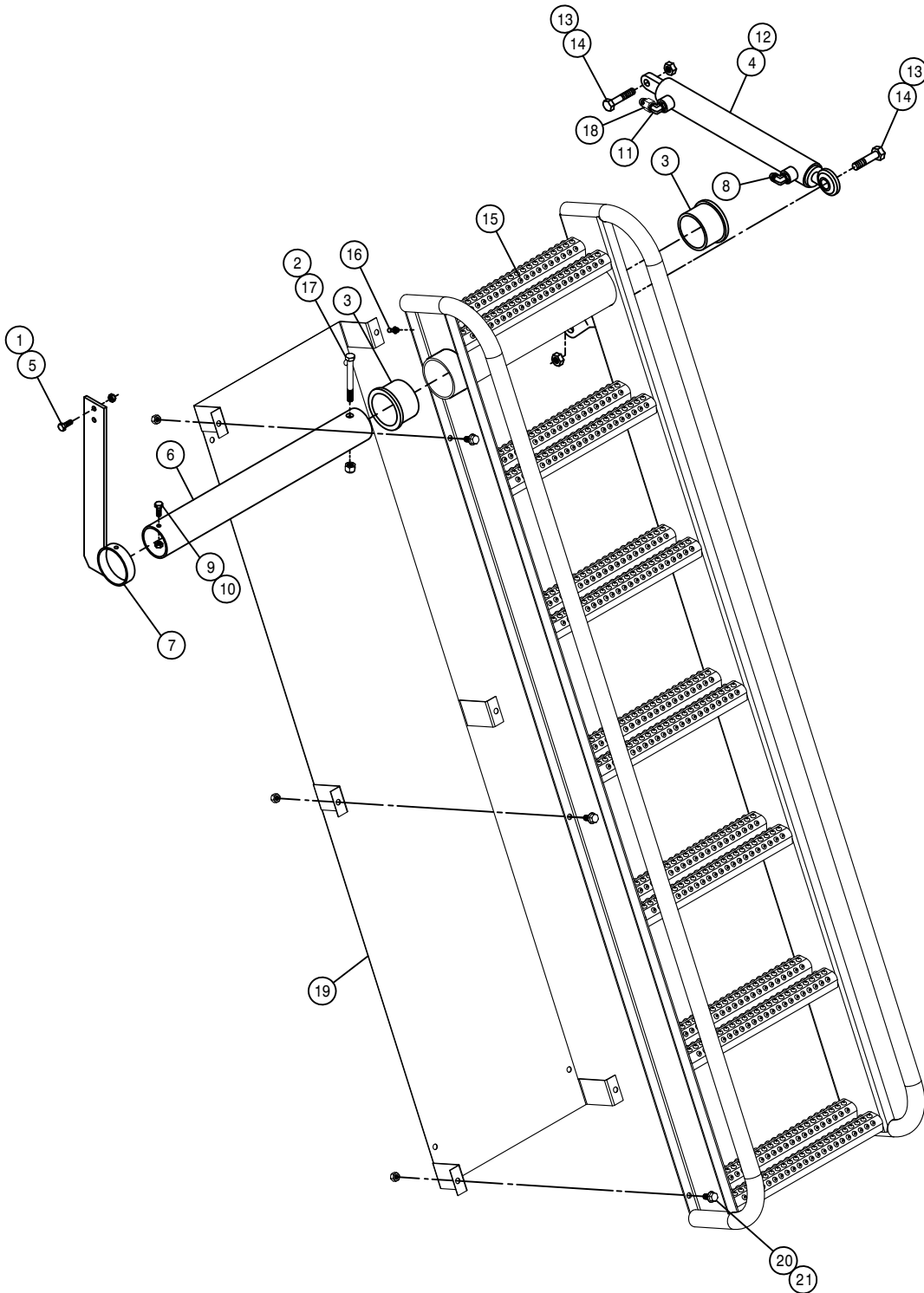

LADDER ASSEMBLY

DET. QTY PART NO. DESCRIPTION

DET.	QTY	PART NO.	DESCRIPTION
1	2	914002	5/16UNC HEX STOVER NUT
2	1	473007	1/2UNC HEX NUT, NYLOC
3	2	121102	LADDER PIVOT BEARING POLYGON
4	1	621554	HYD CYL, 1.50 X 12.25 X .750
5	2	900065	5/16UNC X 1" HEX BOLT
6	1	342805	LADDER MT TUBE
7	1	342806	LH PLTFRM SUPP BRKT WLD, STS12
8	1	618688	9/16MJ-90-9/16MOR .025 CHK VLV
9	1	914000	1/4UNC HEX STOVER NUT
10	1	900003	1/4UNC X 1" HEX BOLT
11	1	618119	9/16MJIC-90-9/16MOR LBO
12	1	621555	REPAIR KIT, HYD CYL 621554
13	2	914008	1/2UNC HEX STOVER NUT
14	2	900267	1/2UNC X 2" HEX BOLT
15	1	343808	LADDER WLDMNT, STS10/16 '11
16	1	471005	GREASE ZERK, 1/4 28 X 1/2
17	1	900275	1/2UNC X 4 1/2 HEX BOLT
18	1	618733	9/16JIC .042 ORIFICE ADPTR
19	1	344009	STEP BACKPLATE, STS CE '11
20	6	900128	3/8UNC X 3/4 HEX BOLT
21	6	914004	3/8UNC HEX STOVER NUT

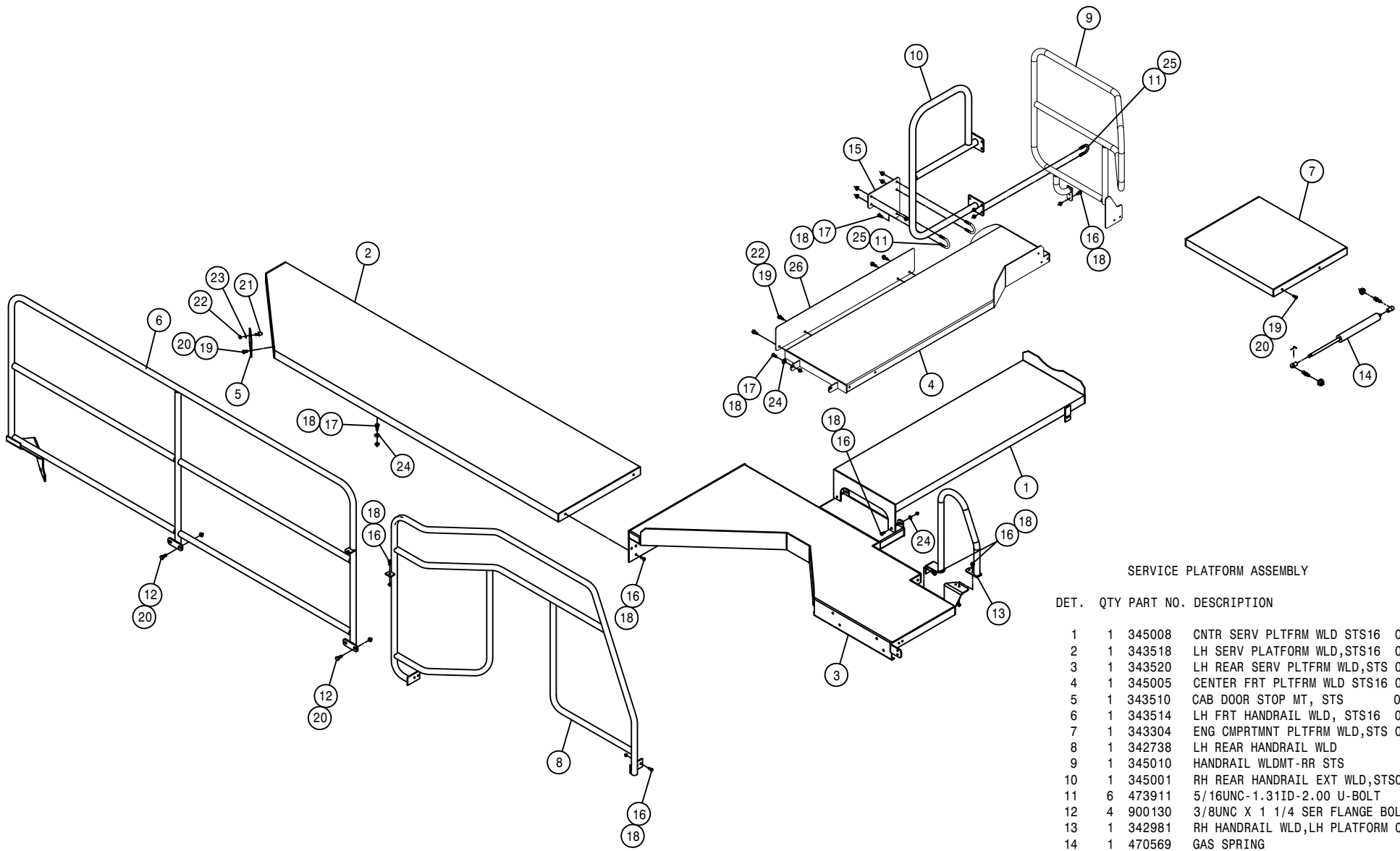

SERVICE PLATFORM ASSEMBLY

DET.	QTY	PART NO.	DESCRIPTION
	1	345008	CNTR SERV PLTFRM WLD STS16 07
	1	343518	LH SERV PLATFORM WLD,STS16 05
	1	343520	LH REAR SERV PLTFRM WLD,STS 05
	4	345005	CENTER FRT PLTFRM WLD STS16 07
	5	343510	CAB DOOR STOP MT, STS 05
	6	343514	LH FRT HANDRAIL WLD, STS16 05
	7	343304	ENG CMPRTMNT PLTFRM WLD,STS 04
	8	342738	LH REAR HANDRAIL WLD
	9	345010	HANDRAIL WLDMT-RR STS
	10	345001	RH REAR HANDRAIL EXT WLD,STS06
	11	473911	5/16UNC-1.31ID-2.00 U-BOLT
	12	900130	3/8UNC X 1 1/4 SER FLANGE BOLT
	13	342981	RH HANDRAIL WLD,LH PLATFORM 05
	14	470569	GAS SPRING
	15	345015	RR HANDRAIL MT,STS10/12/14 08
	16	900064	5/16UNC X 3/4 HEX BOLT
	17	900065	5/16UNC X 1" HEX BOLT
	18	914002	5/16UNC HEX STOVER NUT
	19	900129	3/8UNC X 1" SERR FLANGE BOLT
	20	914004	3/8UNC HEX STOVER NUT
	21	470571	BUMPER,MALE STUD 2.375 X 1.75
	22	470087	3/8UNC HEX FLANGE LOCK NUT
	23	920502	3/8 LOCK WASHER
	24	920001	5/16 SAE FLAT WASHER
	25	470113	5/16UNC HEX FLANGE LOCK NUT
	26	343094	TOE KICK PLT,STS14

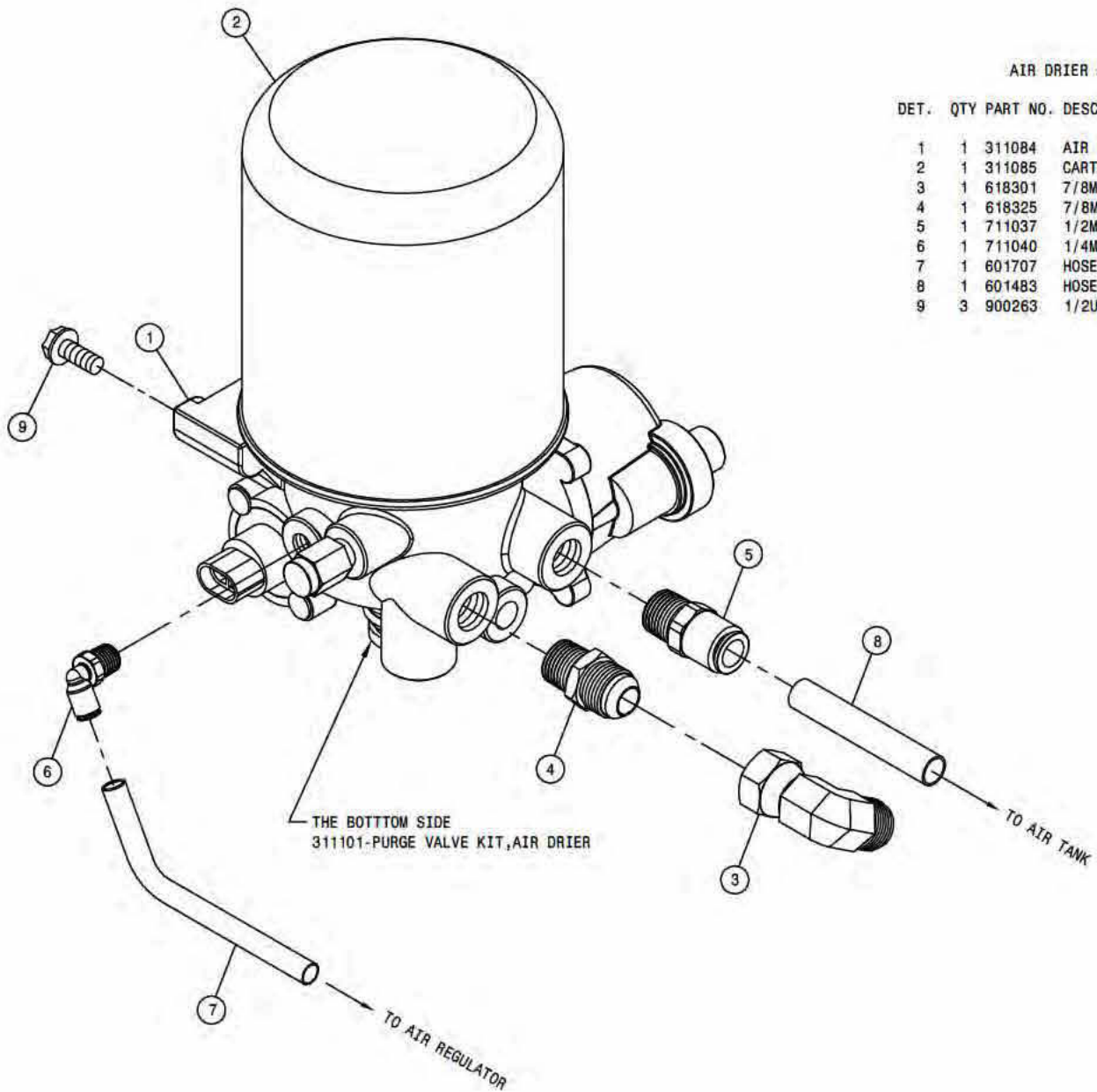

AIR DRIER ASSEMBLY

DET.	QTY	PART NO.	DESCRIPTION
1	1	311084	AIR DRIER,SYSTEM SAVER 1200
2	1	311085	CARTRIDGE KIT FOR 311084 DRIER
3	1	618301	7/8MJIC-90-7/8FJIC SWIV LBO
4	1	618325	7/8MJIC-1/2MNPT ADPTR
5	1	711037	1/2MNPT-1/2 NYL TUBE FTG
6	1	711040	1/4MNPT-90-1/4 NYL TUBE LBO
7	1	601707	HOSE, 1/4 X 63 AIR
8	1	601483	HOSE, 1/2 X 84 AIR
9	3	900263	1/2UNC X 1* HEX BOLT

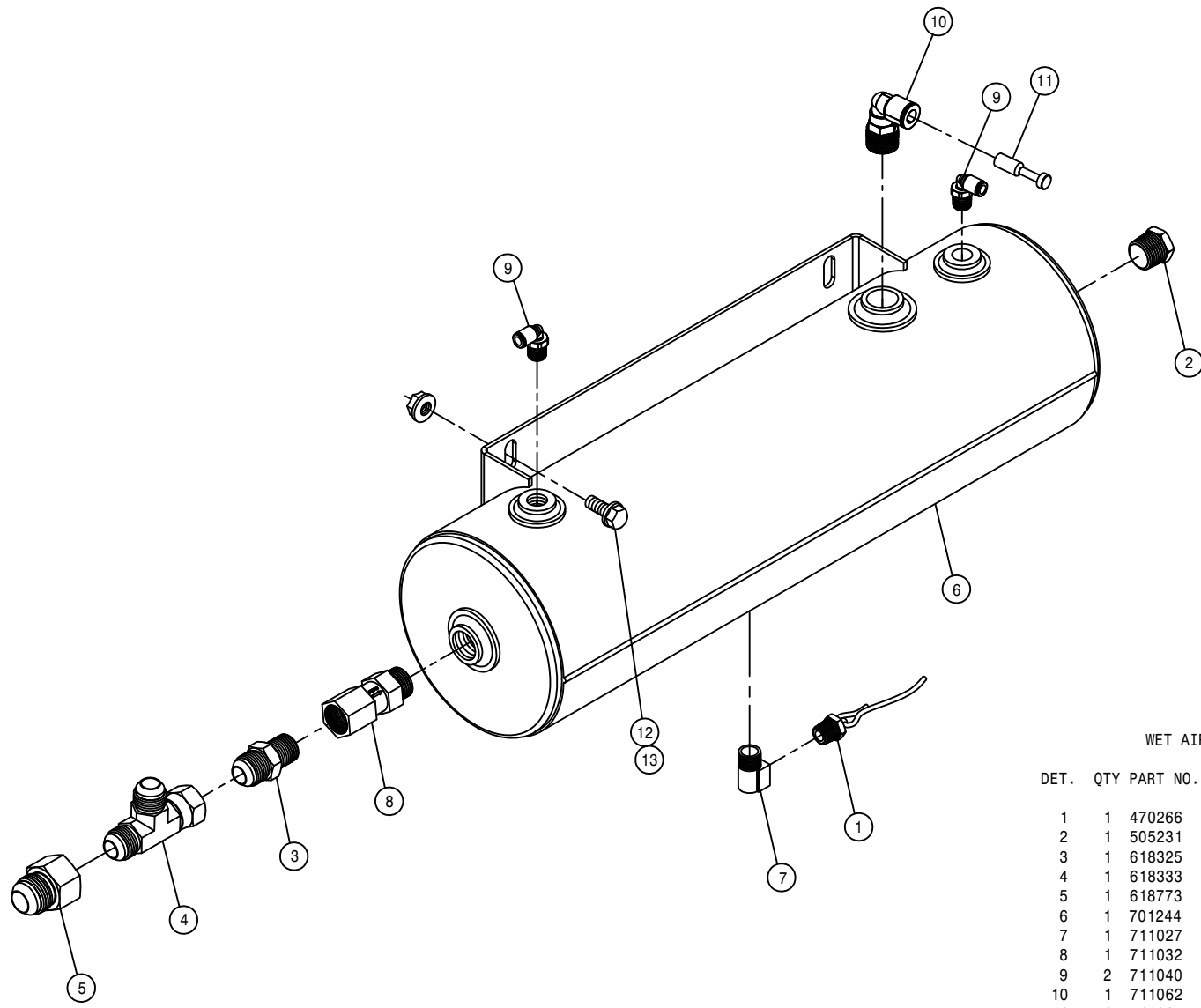

WET AIR TANK ASSEMBLY

DET. QTY PART NO. DESCRIPTION

1	1	470266	DRAIN VALVE KIT, 1/4NPT
2	1	505231	PIPE PLUG .50NPT HEX HD BRS
3	1	618325	7/8MJIC-1/2MNPT ADPTR
4	1	618333	7/8FJIC SW RUN TEE-7/8MJIC
5	1	618773	7/8FJIC-1 1/16MJIC ADPTR
6	1	701244	WET AIR TANK STSLS 16 06
7	1	711027	1/4 NPT ST EL BRS
8	1	711032	CHECK VALVE, 1/2"FNPT-1/2"MNPT
9	2	711040	1/4MNPT-90-1/4 NYL TUBE LBO
10	1	711062	1/2MNPT-90-3/8 NYL 1-TUBE LBO
11	1	711064	RUBBER PLUG FOR 3/8 PISCO CPLR
12	2	900128	3/8UNC X 3/4 HEX BOLT
13	2	470087	3/8UNC HEX FLANGE LOCK NUT

AIR TANK ASSEMBLY

DET. QTY PART NO. DESCRIPTION

1	1	470266	DRAIN VALVE KIT, 1/4NPT
2	1	505228	RED BUSH 3/4MNPT-1/2FNPT, BRS
3	1	505232	RED BUSH 3/4MNPT-1/4FNPT, BRS
4	1	505230	3/4 NPT ST EL BRS
5	1	701154	AIR TANK
6	2	711027	1/4 NPT ST EL BRS
7	1	711037	1/2MNPT-1/2 NYL TUBE FTG
8	1	711045	3/8MNPT-90-1/4 NYL 2-TUBE LBO
9	1	711046	3/8MNPT-90-1/4 NYL 3-TUBE LBO
10	1	311086	CHECK VALVE, PRESS CTRL, WABCO
11	1	601476	HOSE, 1/4 X 120 AIR
12	1	601478	HOSE, 1/4 X 175 AIR
13	1	601592	HOSE, 1/4 X 69 AIR
14	1	601641	HOSE, 1/4 X 222 AIR
15	1	601642	HOSE, 1/4 X 256 AIR
16	1	601483	HOSE, 1/2 X 84 AIR
17	8	920002	3/8 SAE FLAT WASHER
18	4	900130	3/8UNC X 1 1/4 SER FLANGE BOLT
19	4	914004	3/8UNC HEX STOVER NUT
20	1	311081	PROTECTION VALVE, JACOBS
21	1	502707	PIPE NIPPLE, 1/4NPT HEX, BRS
22	1	711049	1/4 NYL TUBE-1/4MNPT FTG
23	1	601671	HOSE, 1/4 X 145 AIR
24	1	711047	3/8MNPT-1/4NYL TUBE, DBL BRANCH
25	1	601394	HOSE, 1/4 X 34 AIR

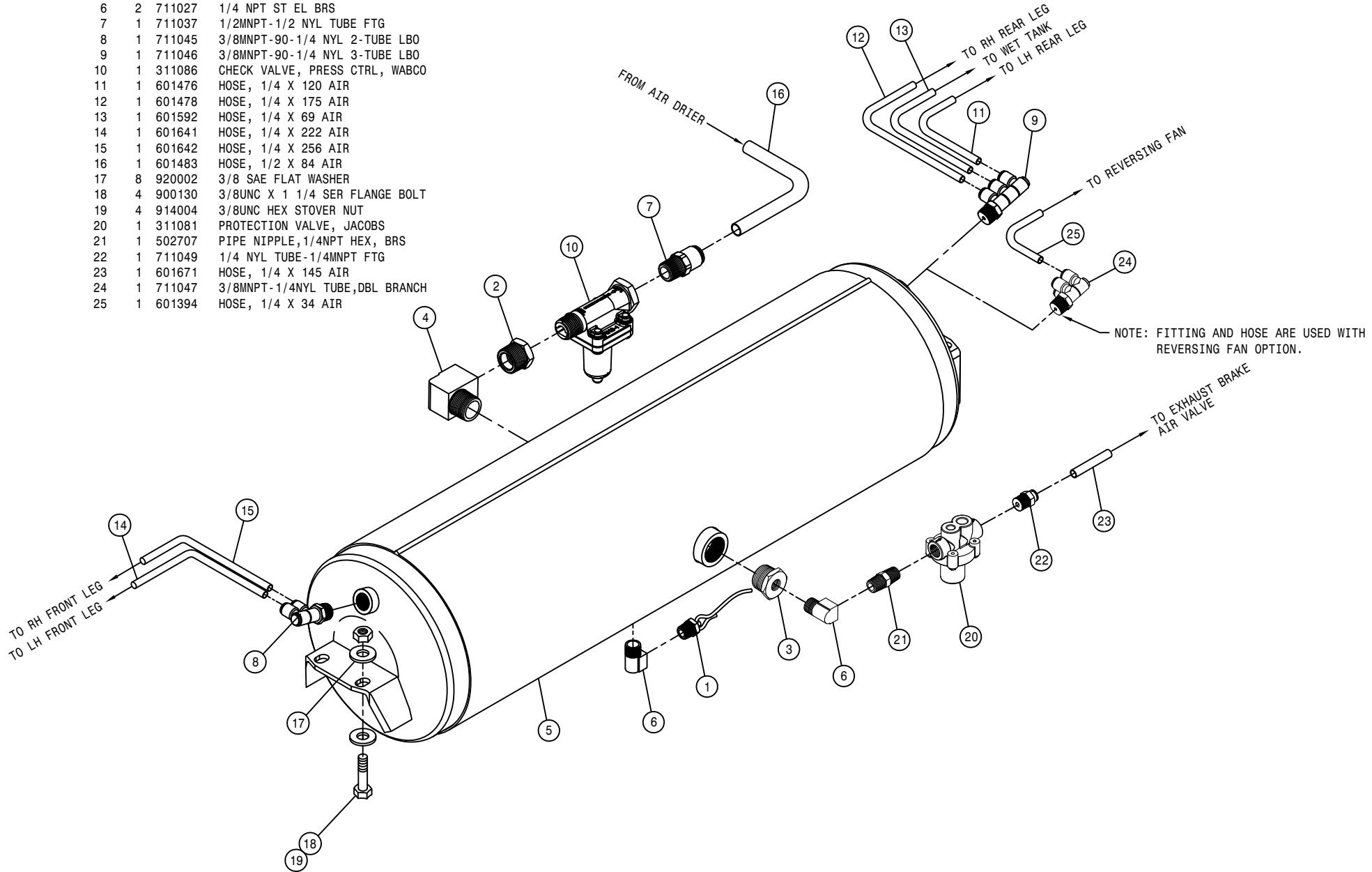

CAB ASSEMBLY (FRONT VIEW)

DET. QTY PART NO. DESCRIPTION

1	1	291749	TERM BLOCK, BLACK, 3/8-16 THRU
2	1	291750	TERM BLOCK, RED, 3/8-16 THRU
3	2	291900	RH WORKLIGHT, FLOOD GLASS
4	2	291901	LH WORKLIGHT, FLOOD GLASS
5	1	291902	RH WORKLIGHT, TRAPEZOID GLASS
6	1	291903	LH WORKLIGHT, TRAPEZOID GLASS
7	1	343431	STRG COLUMN ELECT PANEL, STS 05
8	1	343663	AUX. ACCESS COVER, STS 08
9	1	343433	AUX. ACCESS COVER, STS 05
10	1	343552	CAPLUG, 2X3 W/.75 HOLE, STS 05
11	1	343553	CAPLUG, 2X3 W/1.31 HOLE, STS 05
12	1	343830	CAB WELDMNT, STS '11
13	5	470087	3/8UNC HEX FLANGE LOCK NUT
14	1	470118	1/4UNC X 3/4 FLANGE HEX BOLT
15	12	470122	1/4UNC X 1/2 FLANGE HEX BOLT
16	4	470234	5/16UNC X 1" FLANGE HEX BOLT
17	12	470380	1/4-20 NUTSERT .027-.165 STL
18	4	470381	5/16-18 NUTSERT .027-.150 STL
19	2	470393	KNOB, 3-BLADE BLK, 5/16-18X1/2
20	1	470397	RES-Q-ME TOOL
21	1	470398	BEAD CHAIN, #10 X 4" LONG
22	1	470400	BEAD CHAIN CONNECTOR #10 WHITE
23	1	470426	MOTOR, WINDSHIELD WIPER, STS 05
24	1	470427	BLADE, WINDSHIELD WIPER STS 05
25	1	470428	ARM, WNDSHLD WIPER BLADE, STS 05
26	1	470429	SPRAY JET, WNDSHLD WIPER, STS 05
27	1	470503	SLAVE SHAFT, WINDSHIELD WIPER
28	1	470504	PIVOT SHAFT, 2.337 BALL STUD
29	28	470463	8-32 SERR. FLANGE NUT
30	6	470465	#12 X 3/4 PHIL PAN SHT MTL SCR
31	4	472238	12-24 X 1/2 PHIL PAN HD SCR
32	6	483019	7/8" INTERNAL TOOTH LOCK WASHER
33	2	483020	5/8" INTERNAL TOOTH LOCK WASHER
34	4	520080	HOSE CLAMP NO 10 STAINLESS
35	1	601678	HOSE, 5/8 X 8 HEATER
36	1	601679	HOSE, 5/8 X 13 HEATER
37	2	618497	7/8MJIC-7/8MJIC BLKHD UNION
38	2	629762	CAPPLUGS PLUG, 5/8" RD, BLK POLY
39	2	711101	5/8 HOSE BARB-7/8FJX ADPTR, BRS
40	4	903706	10-32X1/2 PHIL PAN MACH SCR
41	4	920510	#10 LOCK WASHER
42	4	910027	10-32 HEX NUT
43	22	903844	8-32 X 1/2 PHIL PANHD MACH SCR
44	1	657475	A/C HOSE ASSY, 5/16X12.50 BLKHD
45	1	657476	A/C HOSE ASSY, 1/2X12.50 BLKHD
46	1	657500	A/C & HEATER BLOWER SYS, STS 07
47	1	290062	HORN, FREEWAY BLASTER 130 DB
48	1	470121	1/4UNC HEX FLANGE LOCK NUT
49	2	470113	5/16UNC HEX FLANGE LOCK NUT
50	2	470233	5/16UNC X 3/4 FLANGE HEX BOLT
51	2	920502	3/8 LOCK WASHER
52	1	290059	BEACON, 12V AMBER HALOGEN
53	1	290060	BEACON TILT SURFACE MT, QK CHG

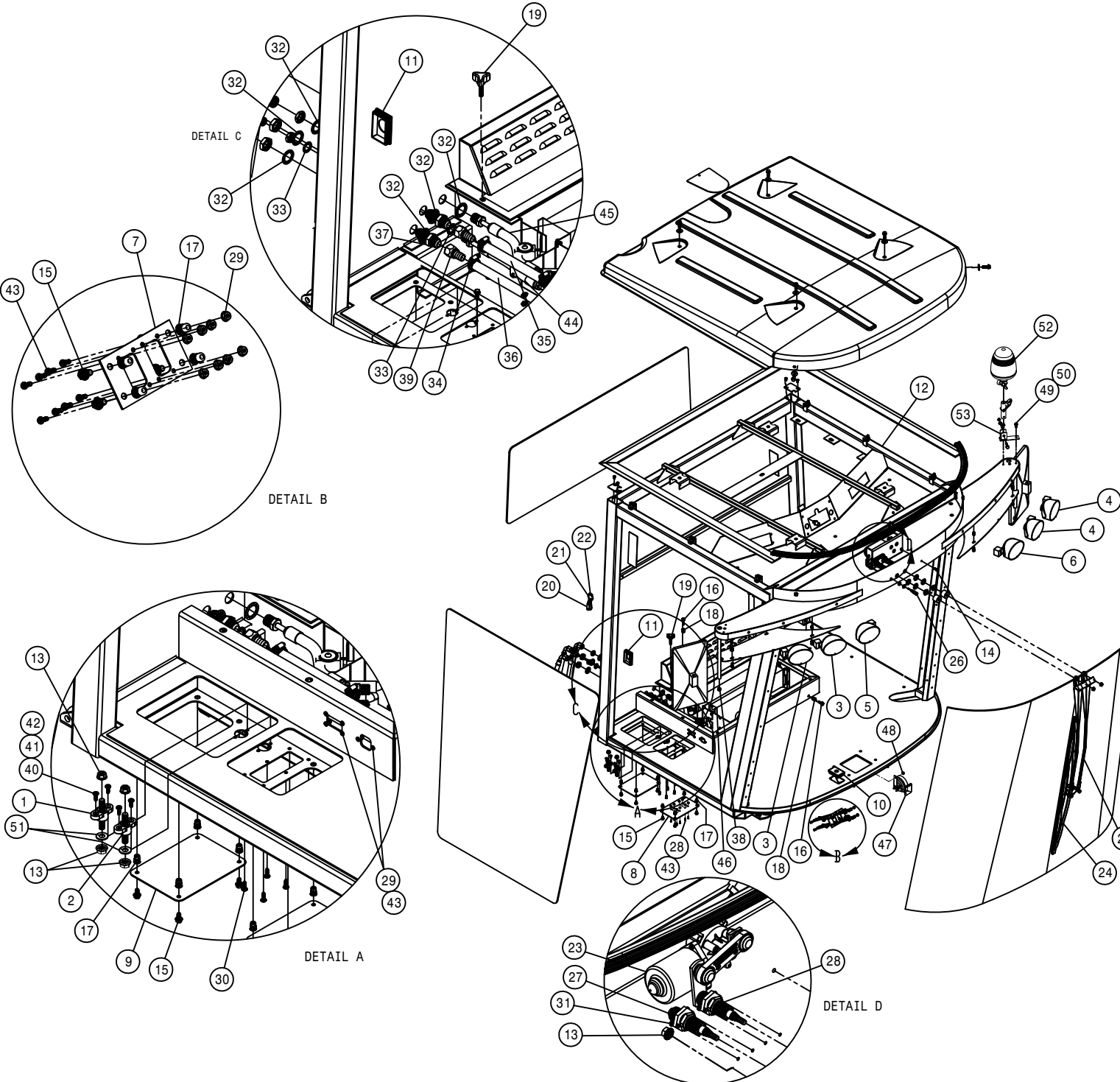

CAB ASSEMBLY (REAR VIEW)

DET. QTY PART NO. DESCRIPTION

DET.	QTY	PART NO.	DESCRIPTION
1	4	291009	ROSEBUD CLIP FOR .625 CONDUIT
2	4	291010	ROSEBUD CLIP FOR 1.000 CONDUIT
3	1	311533	3.00 90 DEG COBRA ELBOW RUBBER
4	1	311534	RAIN CAP, 3.00 PLASTIC
5	1	343824	CAB ROOF STS'11
6	1	343351	GPS MTG PLATE, STS CAB 05
7	2	343352	LWR LIGHT MT COVER, STS CAB 05
8	1	343712	WIPER MTR MT WLD, STS CAB '10
9	1	343422	HVAC INTAKE TUBE WLD, STS CAB05
10	1	343434	CAB ENTRY STEP PLATE, STS 05
11	1	343582	FRT CAB ROOF SEAL, STS CAB 06
12	1	343583	CAB ROOF SEAL, STS CAB 06
13	1	470417	STRIKER PIN ASSY
14	1	343605	RH REAR CORNER POST CAP, STS 07
15	1	343606	LH REAR CORNER POST CAP, STS 07
16	1	343830	CAB WELDMENT STS'11
17	1	343642	HVAC ACCESS COVER, STS 08
18	14	470118	1/4UNC X 3/4 HHSFB GR5 MC
19	2	470121	1/4UNC SER FLG LOCK NUT
20	4	470234	5/16UNC X 1" SER FLG HEX BOLT
21	6	470329	3/8UNC X1 1/4 SER FLG HEX BOLT
22	2	470348	MIRROR STS10 & STS12
23	1	473852	12MM-1.75 SERR FLANGE NUT, ZINC
24	6	470377	3/8 X 1 3/16 BONDED WASHER SS
25	11	910127	1/4-20 NUTSERT .027-.165YZ
26	4	470526	3/8UNC U-NUT, 1.125 CLIP ON
27	1	470440	WINDSHIELD WASHER TANK ASSY 05
28	2	470491	GROMMET, .75ID .125GW 1.25GD
29	4	910130	10-32 NUTSERT .020-.130 YZ
30	2	520130	3.31/3.59 T-BOLT HOSE CLAMP SS
31	1	650164	DECAL, NO PASSNGR, NOT NEAR LEAK
32	1	650165	DECAL, PWR LINE/BM FOLD/GLASS
33	1	650176	DECAL, CAUTION, CAB CHEM EXPOSUR
34	2	657479	10-213-10FJX-10FJX90-22 H/A
35	1	658035	WINDSHIELD, STS CAB 05
36	1	658036	RH CAB GLASS, STS 05
37	1	658038	REAR CAB GLASS, STS 05
38	3	900050	1/4UNC X 1 1/4 PH FLHD MAC SCR
39	4	903708	1/4UNCX1/2 PHL PNHD MCH SCR BZ
40	1	657477	A/C HOSE ASSY, 5/16 X 24"
41	1	657478	A/C HOSE, 10-10F-10F90-24
42	8	470087	3/8UNC HEX SER FLG NUT
43	4	311078	SNUBBING WASHER FOR 311077 05
44	4	311077	ISOLATION MOUNT, LF1.5 SER 05
45	8	470460	3/8UNC X 1 SER FLG BOLT
46	4	470461	1/2UNC X 3 SER FLG BOLT
47	4	470345	1/2UNC HEX SMTH FLG LOCK NUT
48	1	291915	SWITCH, PANEL MT PUSH BUTTON
49	1	193037	STICKERTITE 1/8 X 3/4
50	4	910128	5/16-18 NUTSERT .027-.150 YZ
51	4	193022	STICKERTITE 1/4 X 3/4
52	1	291964	SWITCH BOOT FOR 291915
53	1	291214	ANTENNA
54	2	193016	QUICKEDGE TRIM .060 TO .170

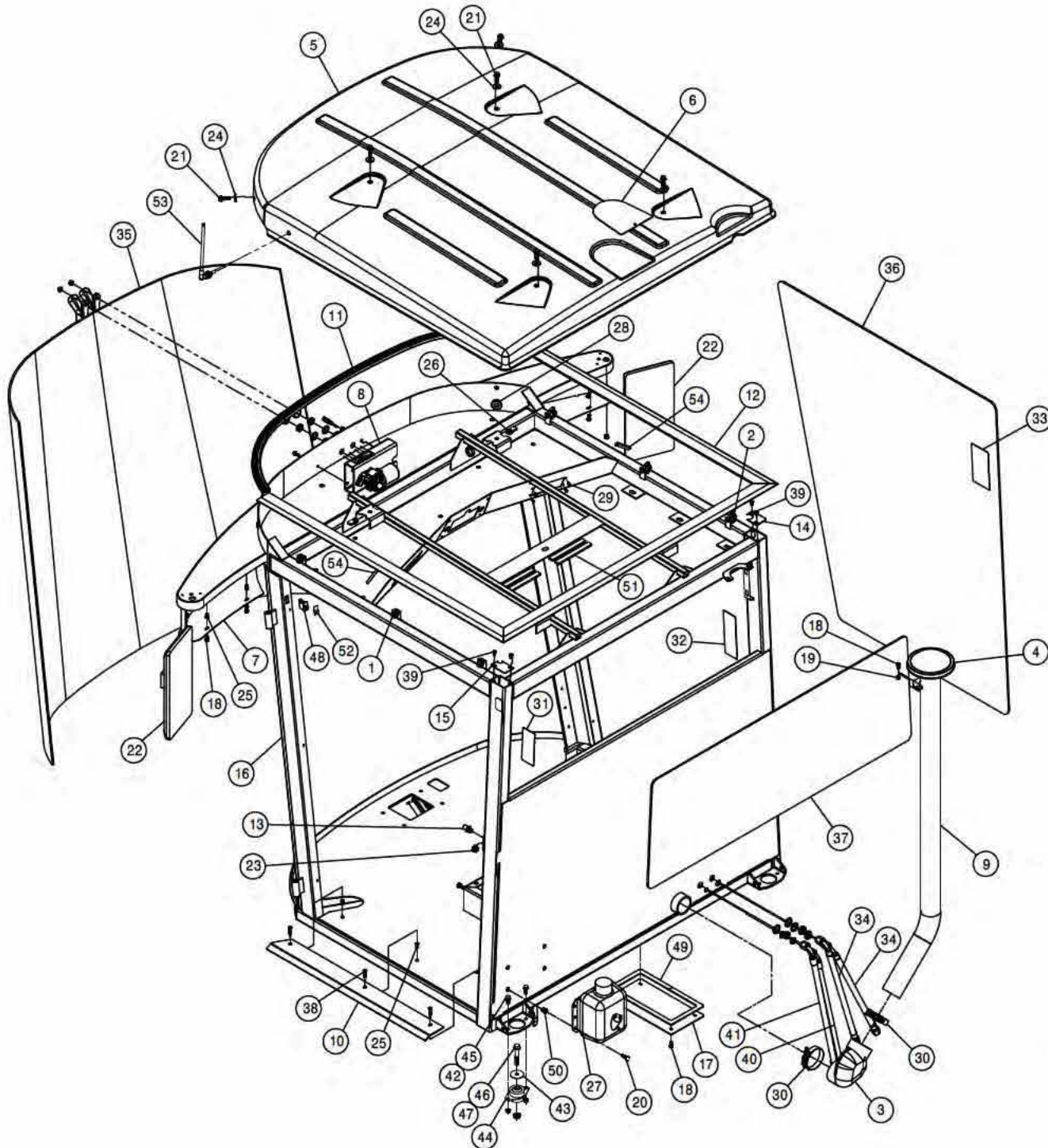

HEADLINER ASSEMBLY

DET. QTY PART NO. DESCRIPTION

1	8	470384	10-32 NUTSERT .020-.130 STL
2	2	473907	#10X5/8 OHPHIL 8 SHT MTL SCR
3	1	291909	L.E.D. COURTESY LIGHT W/LEADS
4	1	291912	DOME LIGHT
5	1	291913	TRIM RING, DOME LIGHT 291912
6	2	291922	SPEAKERS,PAIR
7	8	472235	10-32 X 3/4 PHIL PAN MACH SCR
8	1	291932	RADIO, AM/FM/WB/CD
9	1	658336	HEADLINER, STS/GST '10
10	1	292214	SWITCH, WASHER, STS
11	1	292215	SWITCH, WIPER, STS
12	2	292216	SWITCH,WORK/FIELD LIGHTS, STS
13	2	292261	MOUNTING TRIM,END VME
14	3	292262	MOUNTING TRIM, MIDDLE VMM
15	1	292270	SWITCH BLANK, VH2
16	19	483067	1/4 X 1.00 OD FENDER WASHER
17	1	343331	RADIO BEZEL,CAB, BLK PLASIC 05
18	4	473990	#8 X 3/4 PHIL PAN SHTMTL(A)SCR
19	1	343607	BEZEL,LIGHT/WIPER GST20 07
20	19	470457	1/4-20 WING NUT, NYLON
21	19	470456	1/4-20 X 1.00 STUD,SQ BASE,NYL
22	1	166856	BOOM SECT IND LIGHT PLT,STS'11

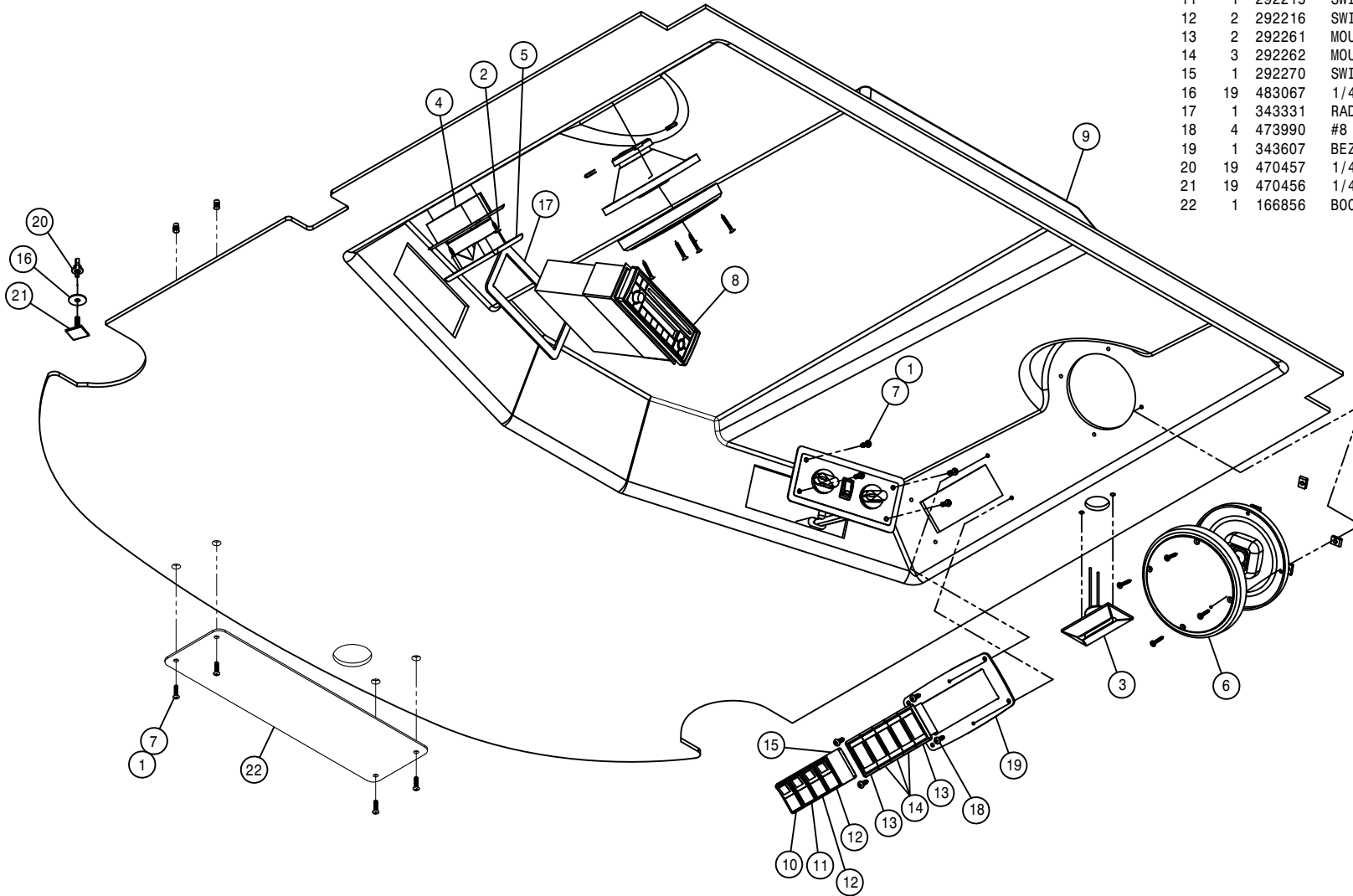

330103-TRIGGERING MECHANISM(CTRL KIT)
 330104-132146 SEAT AIR ADJ SWITCH
 330105-COMPRESSOR KIT

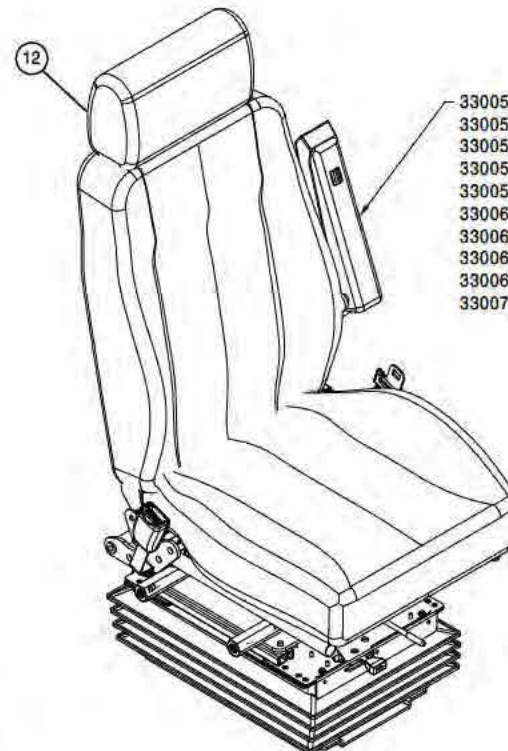
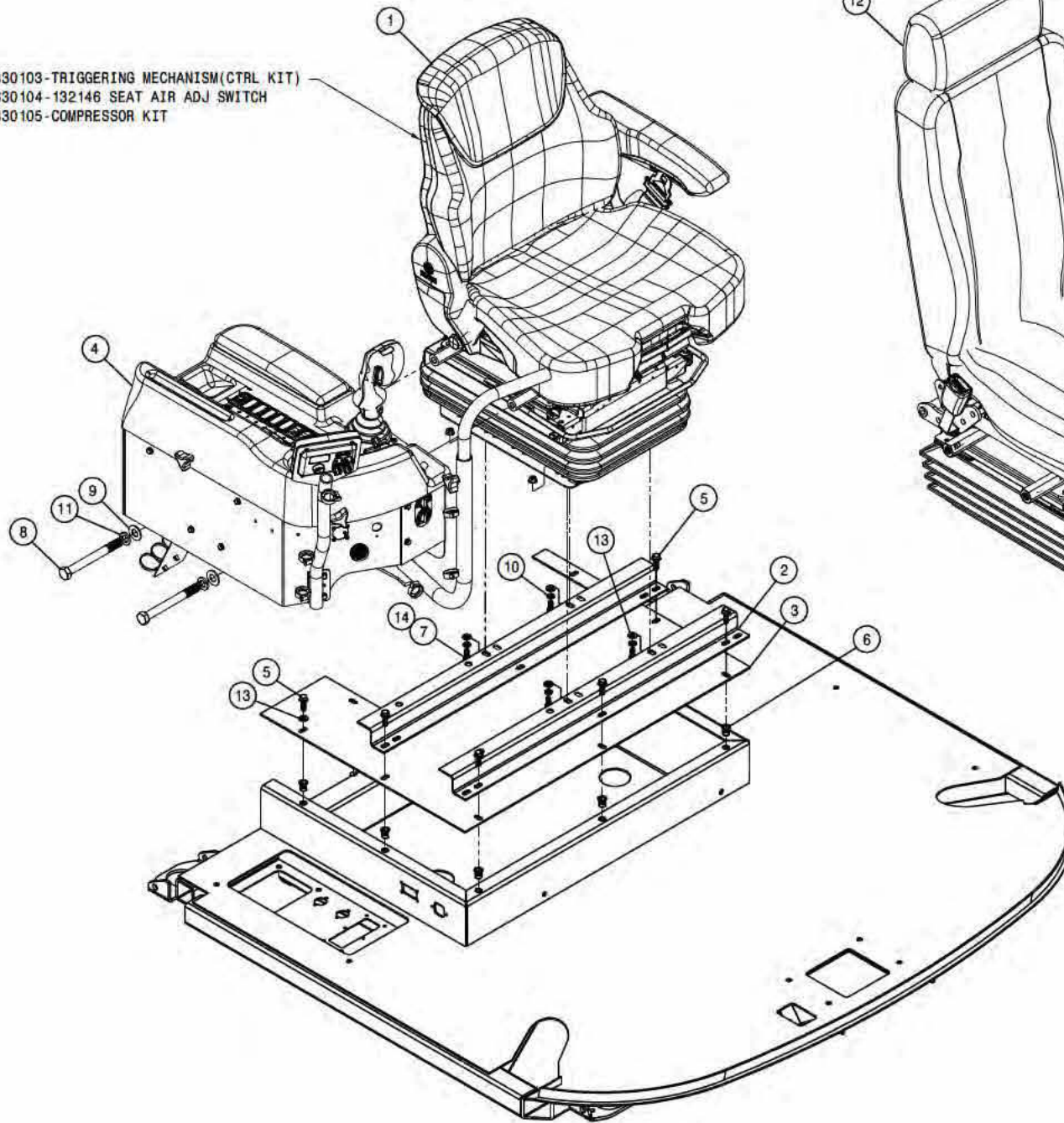

330050-HD SUSPENSION KIT,12V,KNOEDLER
 330056-98 DUAL LOCK SLIDE KIT(LONG)
 330057-SEAT BELT KIT,RETRACTABLE
 330058-98 SEAT CUSHION,GREY W/OPS
 330059-9400 LH HEIGHT ADJ VALVE,ELECT
 330060-9400 LH LUMBAR VALVE,ELECT
 330061-LH ARMREST,GREY LEATHER GH725
 330062-98 HEADREST,GREY W/HAGIE LOGO
 330063-98 BACKREST,GREY W/O HEADREST
 330076-CHECK VALVE,KNOEDLER SEAT

SEAT ASSEMBLY

DET.	QTY	PART NO.	DESCRIPTION	
1	1	330047	SEAT, STS GRAMMER	'11
2	2	343429	SEAT BASE STIFF, STS CAB	05
3	1	343430	HVAC LID, STS CAB	05
4	1	343821	SIDE CONSOLE ASSY, STS	'11
5	6	470233	5/16UNC X 3/4 FLANGE HEX BOLT	
6	8	470381	5/16-18 NUTSERT .027-.150 STL	
7	4	473827	BMM-1.25 X 20MM HEX BOLT	
8	2	900346	5/8UNC X 6" HEX BOLT	
9	2	920005	5/8 SAE FLAT WASHER	
10	4	920501	5/16 LOCK WASHER	
11	2	920505	5/8 LOCK WASHER	
12	1	330048	SEAT, STS KNOEDLER	'11
13	5	920001	5/16 SAE FLAT WASHER	
14	4	473858	BMM-1.25 SERR FLANGE NUT	

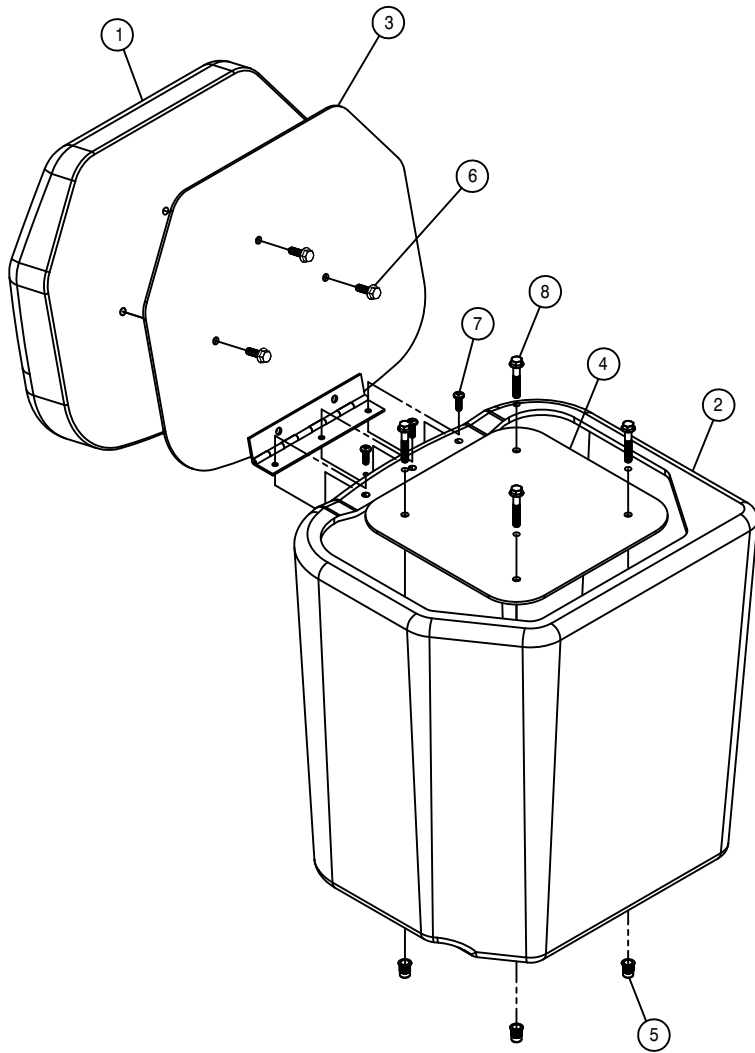

BUDDY SEAT ASSEMBLY

DET.	QTY	PART NO.	DESCRIPTION	
	1	330036	BUDDY SEAT CUSHION	05
	1	330037	BUDDY SEAT BASE, POLY	05
	1	343425	BUDDY SEAT MT WLD, STS CAB	05
	1	343428	BUDDY SEAT MT PANEL, STS CAB	05
	4	470380	1/4-20 NUTSERT .027-.165	STL
	3	470118	1/4UNC X 3/4 FLANGE HEX BOLT	
	3	903710	10-32X5/8 PHIL PANHD MACH SCR	
	4	900005	1/4UNC X 1 1/2 HEX BOLT	

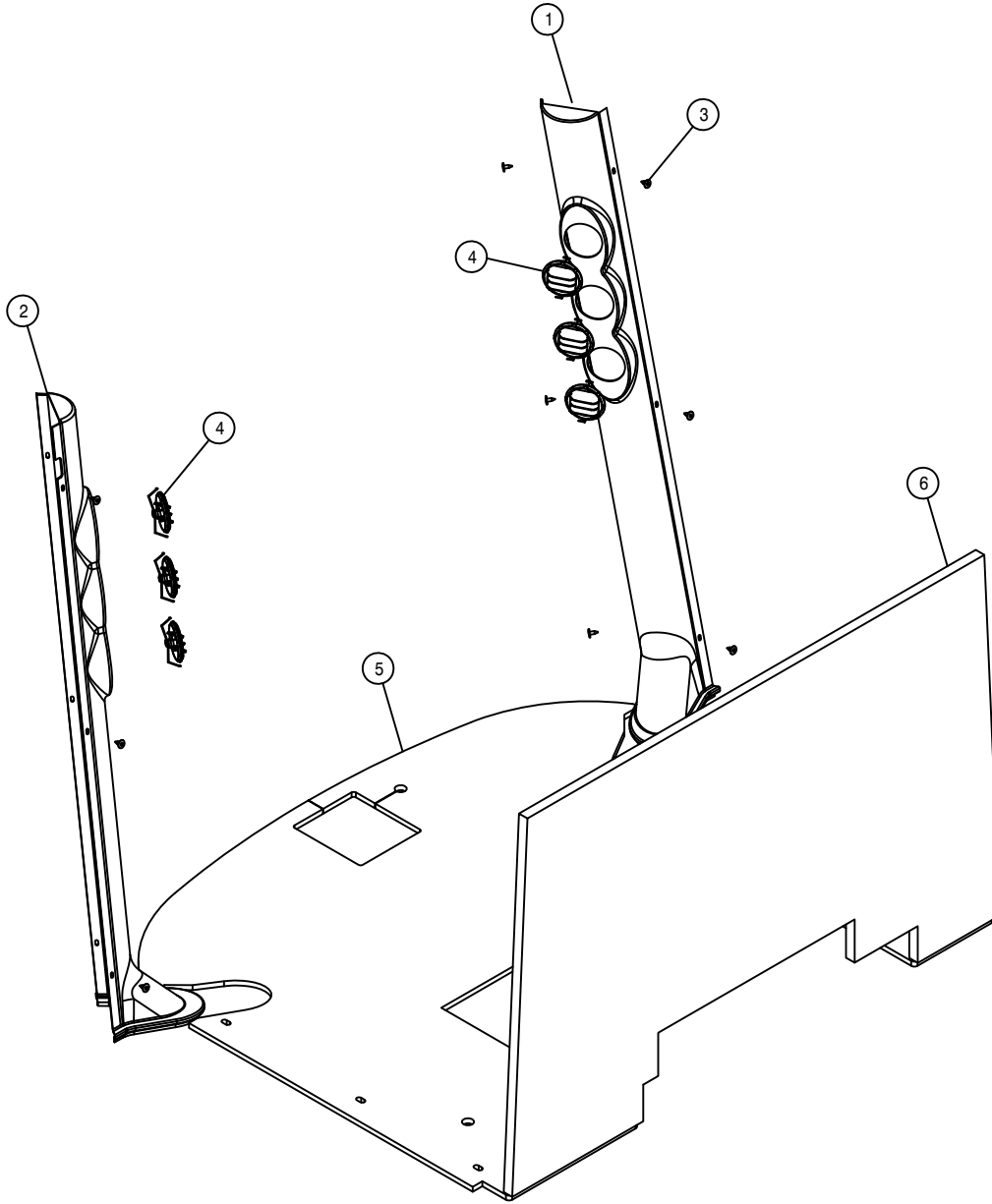

AIR DUCT AND FOAM ASSEMBLY

DET. QTY PART NO. DESCRIPTION

1	1	343356	RH AIR DUCT COVERS,STS CAB	05
2	1	343357	LH AIR DUCT COVERS,STS CAB	05
3	12	470466	1/4 X 3/4 PLTC LCK RIVET	
4	6	657469	LOUVER, ROUND	
5	1	658339	FLOOR MAT, STS CAB	'11
6	1	658333	FOAM, REAR CAB STS	05

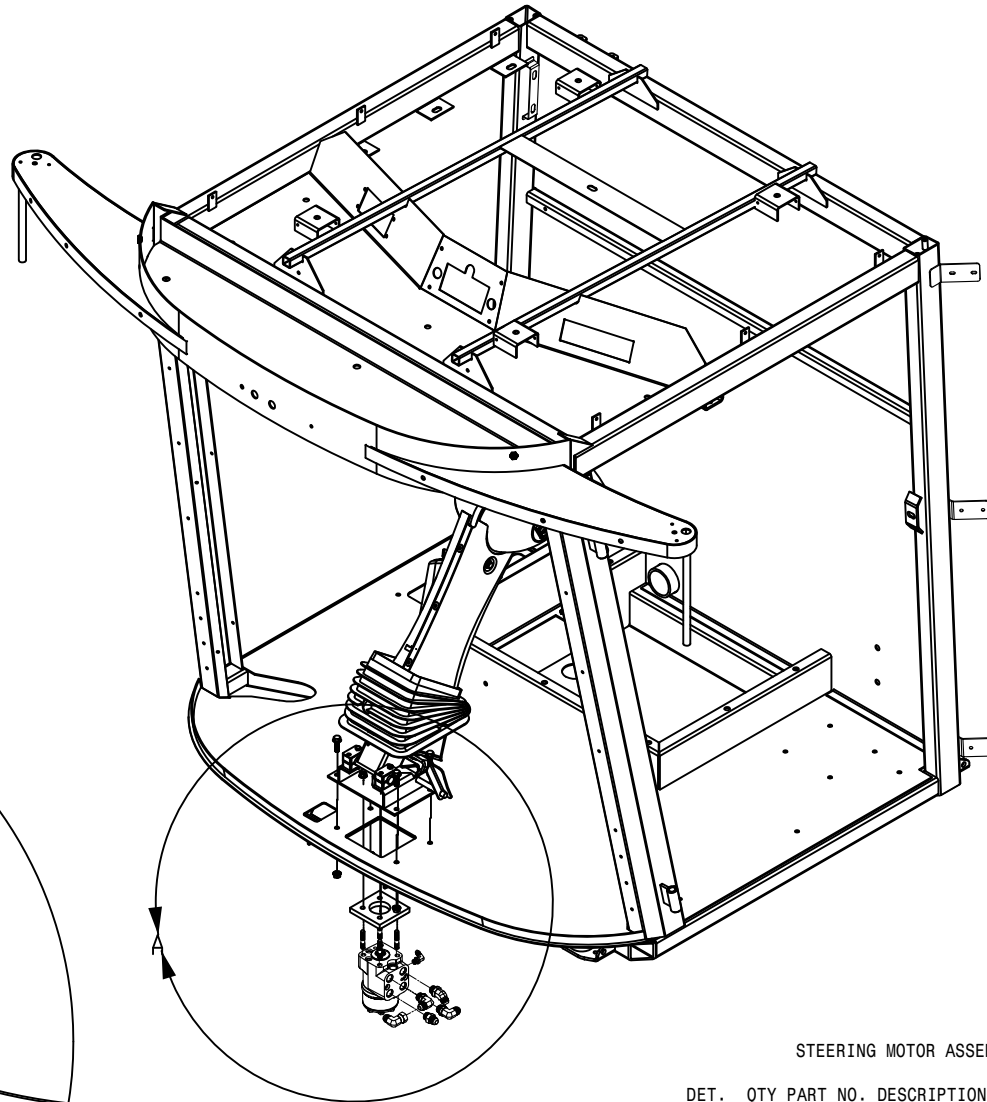
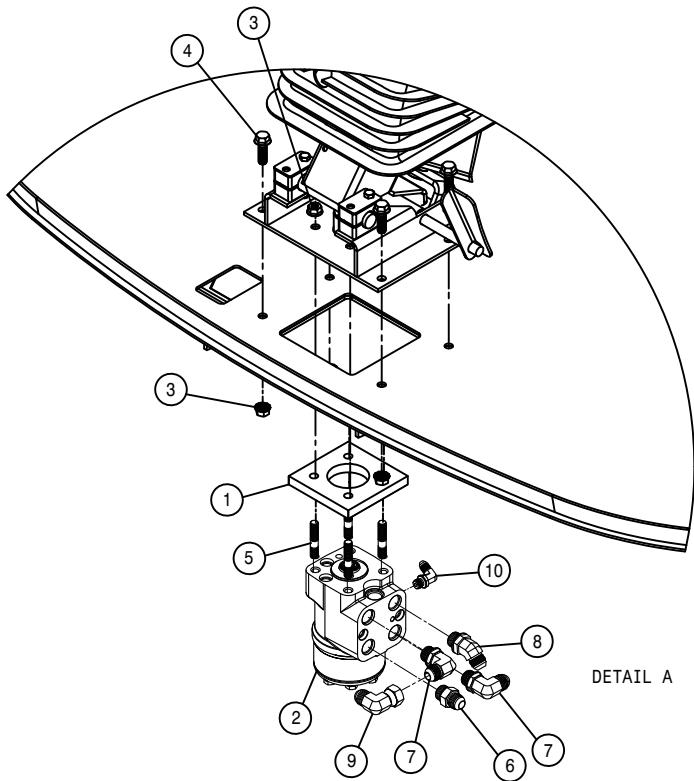

STEERING MOTOR ASSEMBLY

DET.	QTY	PART NO.	DESCRIPTION
1	1	343392	.500 STRG MTR SPACER, STS CAB05
2	1	749331	STEERING CTRL VALVE, LS SAUER
3	8	470087	3/8UNC HEX FLANGE LOCK NUT
4	4	470329	3/8UNC X 1 1/4 SER FLANGE BOLT
5	4	472336	3/8UNC X 2" STUD BOLT, DBL END
6	1	611125	3/4MJIC-3/4MOR ADPTR
7	2	618241	3/4MJIC-90-3/4MOR LBO
8	1	618315	3/4MJIC-45-3/4MOR LBO
9	1	618609	3/4MJIC-90-3/4FJIC SWIV LBO
10	1	618473	7/16MJIC-90-7/16MOR LBO

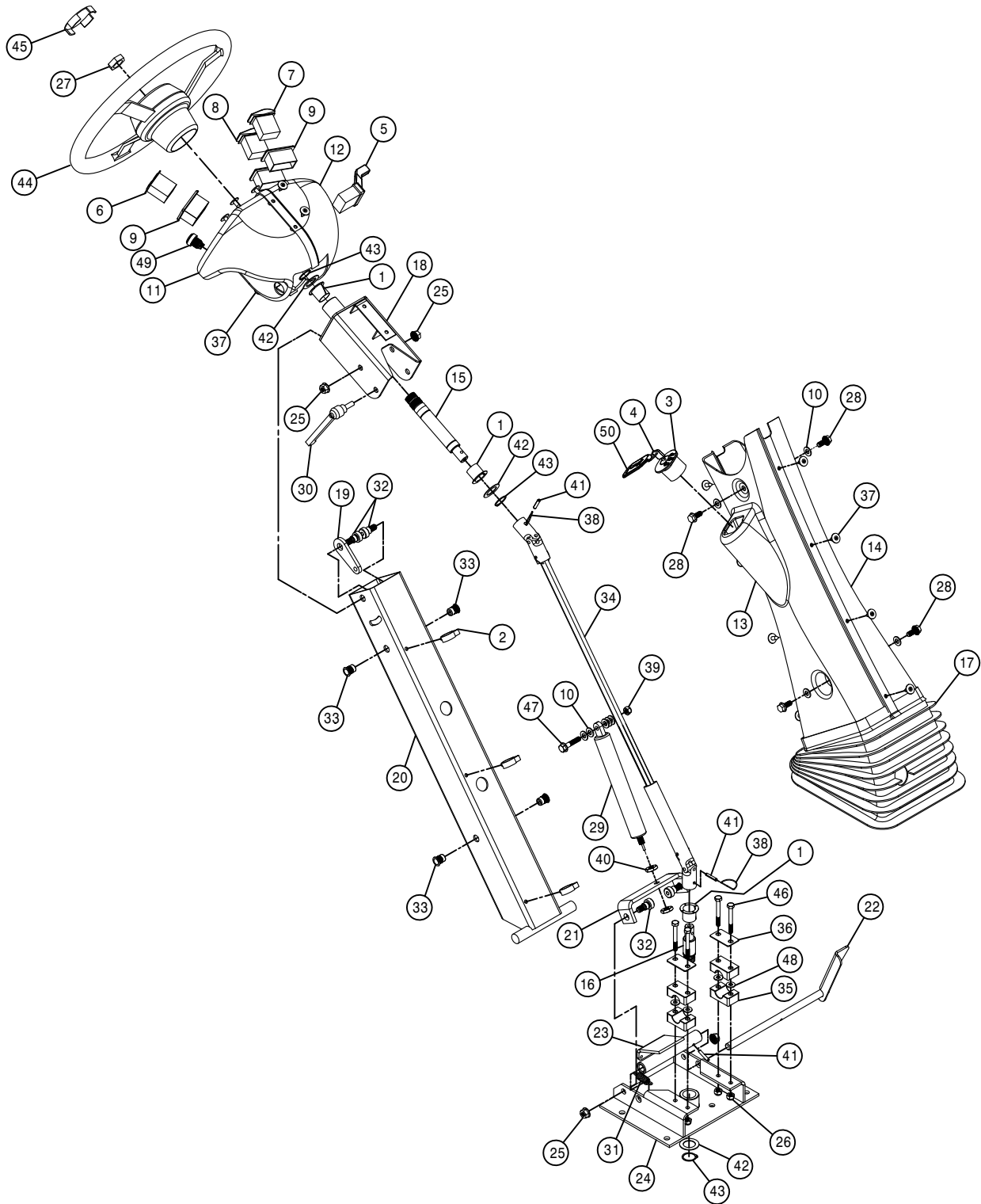

STEERING COLUMN ASSEMBLY

DET. QTY PART NO. DESCRIPTION

1	3	127503	NYLINER FLG BRG, .875 ID
2	3	291006	ROSEBUD CLIP FOR .500 CONDUIT
3	1	291916	IGNITION SWITCH
4	2	291917	IGNITION KEY FOR 291916
5	1	292210	SWITCH, TURN SIGNAL, STS
6	1	292211	TURN INDICATOR W/GREEN LED,STS
7	1	292212	SWITCH,HAZARD,STS
8	1	292213	SWITCH, HEADLIGHTS, STS
9	3	292260	MOUNTING TRIM, SINGLE VMS
10	9	920001	5/16 SAE FLAT WASHER
11	1	343359	RH UPR STRG CLMN COVERS,STS 05
12	1	343360	LH UPR STRG CLMN COVERS,STS 05
13	1	343361	RH LWR STRG CLMN COVERS,STS 05
14	1	343362	LH LWR STRG CLMN COVERS,STS 05
15	1	343364	STRG SHAFT,UPPER COLUMN,STS 05
16	1	343365	STRG SHAFT,LOWER COLUMN,STS 05
17	1	343366	BELLOWS,STEERING COLUMN,STS 05
18	1	343367	STEERING SUPP WELD, STS CAB 05
19	1	343372	STRG COLUMN TOP LOCK, STS CAB
20	1	343373	STEERING COLUMN WLD,STS CAB 05
21	1	343385	GAS SHOCK PIVOT MT,STS CAB 05
22	1	343386	TILT PEDAL WELD, STS CAB 05
23	1	343389	TILT RELEASE WLD, STS CAB 05
24	1	343614	STEERING BASE WELD,STS CAB 07
25	4	910004N	3/8UNC FLANGE CNTR LOCK NUT
26	4	470089	1/4UNC HEX NYLOC NUT, 316 SS
27	1	470157	13/16-20UNEF HEX NUT STRG WHL
28	2	470233	5/16UNC X 3/4 FLANGE HEX BOLT
29	1	470252	GAS SPRING,3.15 STROKE LOCKING
30	1	470257	ADJ HANDLE,3/8-16 STUD, BLACK
31	1	470268	SPRING, EXTENSION, .50 X 1.75
32	4	470283	3/8UNC 1/2 SCKT SHLDR BOLT
33	4	470381	5/16-18 NUTSERT .027-.150 STL
34	1	470401	DRIVE SHAFT ASSY,.625 U-JOINTS
35	2	470405	CLAMP PAIR, 19MM SMOOTH BORE
36	2	470406	TOP CLAMP, SIZE #3 FOR 470405
37	16	470466	1/4 X 3/4 PLTC LCK RIVET
38	4	470479	5"SAFETY LOCK WIRE,304SS .051D
39	1	473001	5/16UNC HEX NUT,NYLOC 316 SS
40	2	473830	10MM-1.00 HEX JAM NUT
41	3	473928	ROLL PIN, 3/16 X 1
42	3	483031	1 3/8 X 7/8 X 18GA MACH WASHER
43	3	629533	SNAP RING, 7/8 EXTRN
44	1	749294	STEERING WHEEL, VIP 14"
45	1	749295	STRG WHL CAP WITH 'H' EMBLEM
46	4	900023	1/4UNC X 2 1/4 HEX BOLT
47	1	900067	5/16UNC X 1 1/2 HEX BOLT
48	4	920022	1/4 FLAT WASH, AN960-416 SS
49	1	292504	HORN SWITCH ASSY
50	1	470544	HAGIE KEY CHAIN

CAB DOOR ASSEMBLY

DET. QTY PART NO. DESCRIPTION

1	8	127502	NYLON FLANGE BRG	
2	2	343332	CAB DOOR HINGE PIN,SS	05
3	2	473928	ROLL PIN, 3/16 X 1	
4	2	470113	5/16UNC HEX FLANGE LOCK NUT	
5	1	470253	HYD DAMPER,100LB,4"STROKE 1084	
6	2	470254	BALL SOCKET, M6 THD X 10MM	
7	2	470255	BALL STUD,5/16-18 THD X 10MM	
8	2	470256	SAFTY CLIP, 10MM BALL SOCKET	

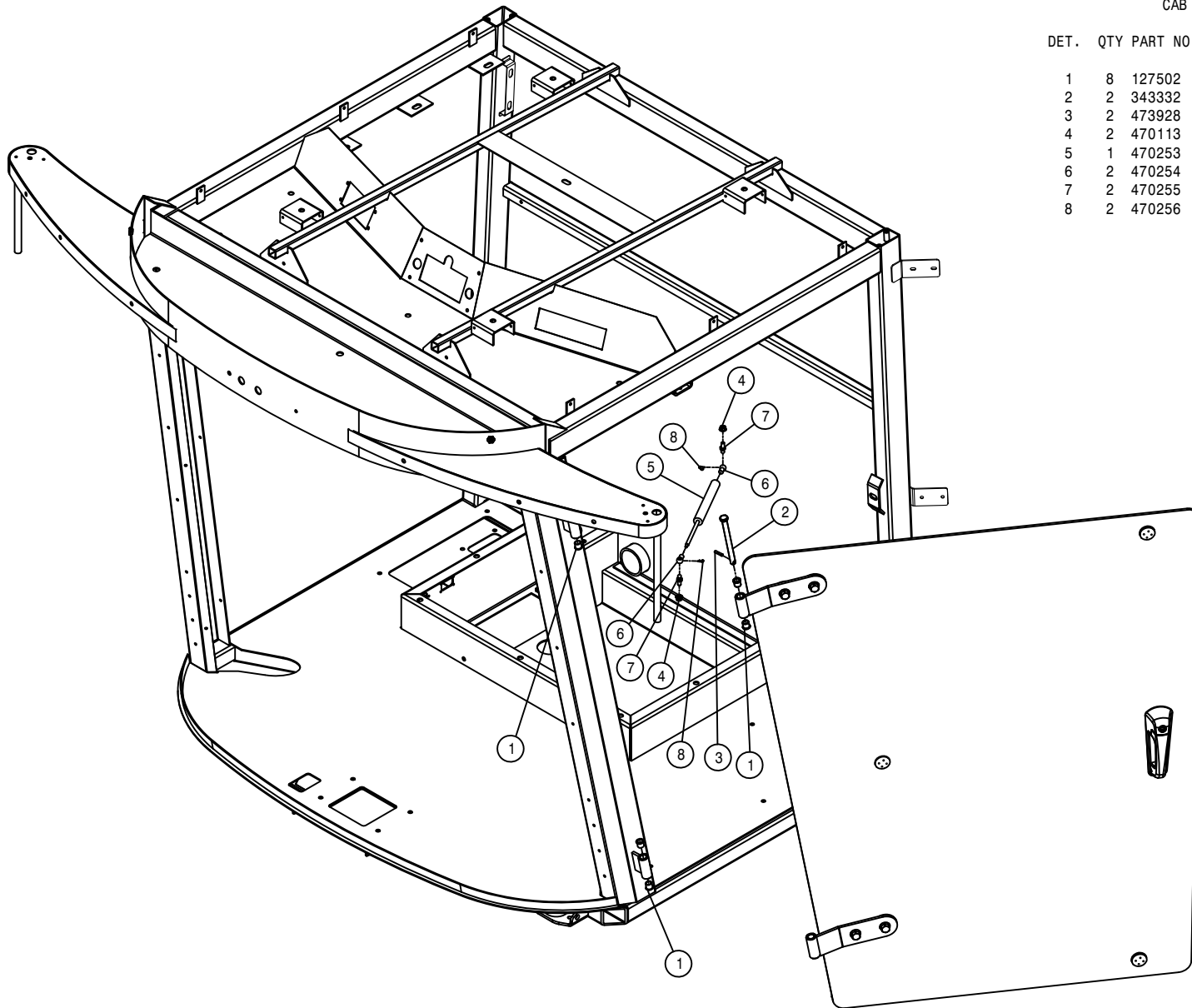

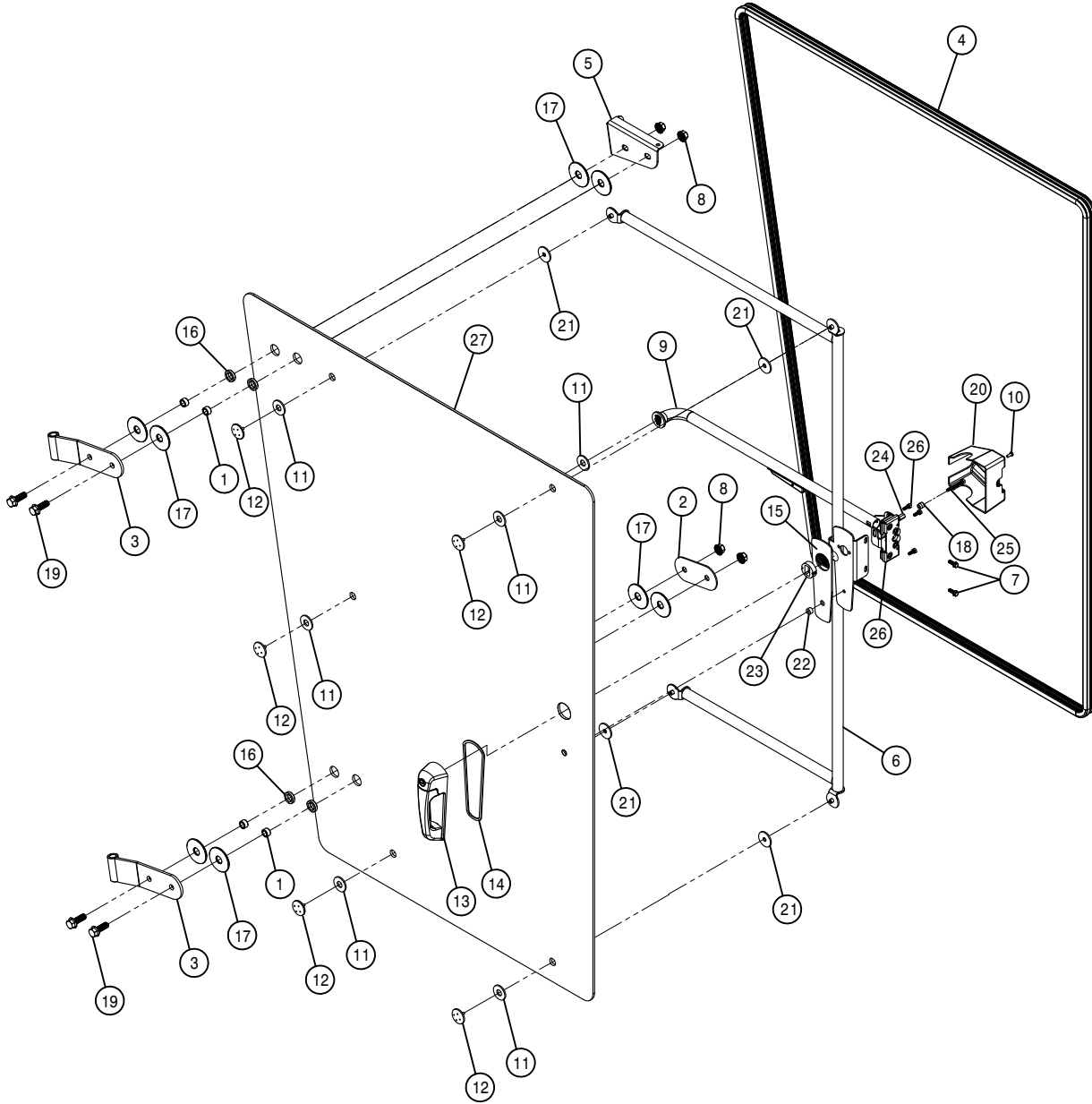

DOOR ASSEMBLY

DET.	QTY	PART NO.	DESCRIPTION	
1	4	343335	DOOR HINGE GLASS BUSH, CAB	05
2	1	343337	LWR DOOR HINGE BACK PLT,	05
3	2	343338	HINGE WELD,CAB	05
4	1	343346	DOOR SEAL, STS CAB	05
5	1	343421	TOP DOOR HINGE PLT, STS	05
6	1	343814	CAB DOOR STIFF WLD, STS	'11
7	2	470118	1/4UNC X 3/4 FLANGE HEX BOLT	
8	4	470360	1/2UNC HEX FLANGE LOCK NUT	
9	1	470583	INSIDE SQUEEZE LATCH ASY,1-POS	
10	1	470412	INSIDE SQUEEZE LATCH SCREWS	
11	6	470413	INSIDE SQUEEZE LATCH GASKET	
12	5	470414	INSIDE SQUEEZE LATCH CAP	
13	1	470415	OUTSIDE PULL HANDLE ASSY	
14	1	470416	OUTSIDE PULL HANDLE GASKET	
15	1	470418	DOOR HANDLE MT GASKET,STS CAB	
16	4	470419	DOOR HINGE BUSH,RUBBER STS	05
17	8	470420	DOOR HINGE WASH,RUBBER,STS	05
18	1	470421	NYLON SPACER, SPHERICAL 6MMX12	
19	4	470431	1/2UNC X 1 1/2 FLANGE BOLT	
20	1	470485	INSIDE SQUEEZE LATCH COVER	07
21	2	470489	GASKET, DOOR HANDLE STIFFENER	
22	1	470496	SPACER,BTM,DOOR HANDLE	470415
23	1	470497	SPACER, TOP,DOOR HANDLE	470415
24	1	473764	6MM-1.00 HEX HIGH NUT	
25	1	473794	6MM-1.00 X 50MM HEX BOLT	
26	3	473826	6MM-1.00 X 16MM HEX BOLT	
27	1	658041	DOOR GLASS, STS CAB	'11

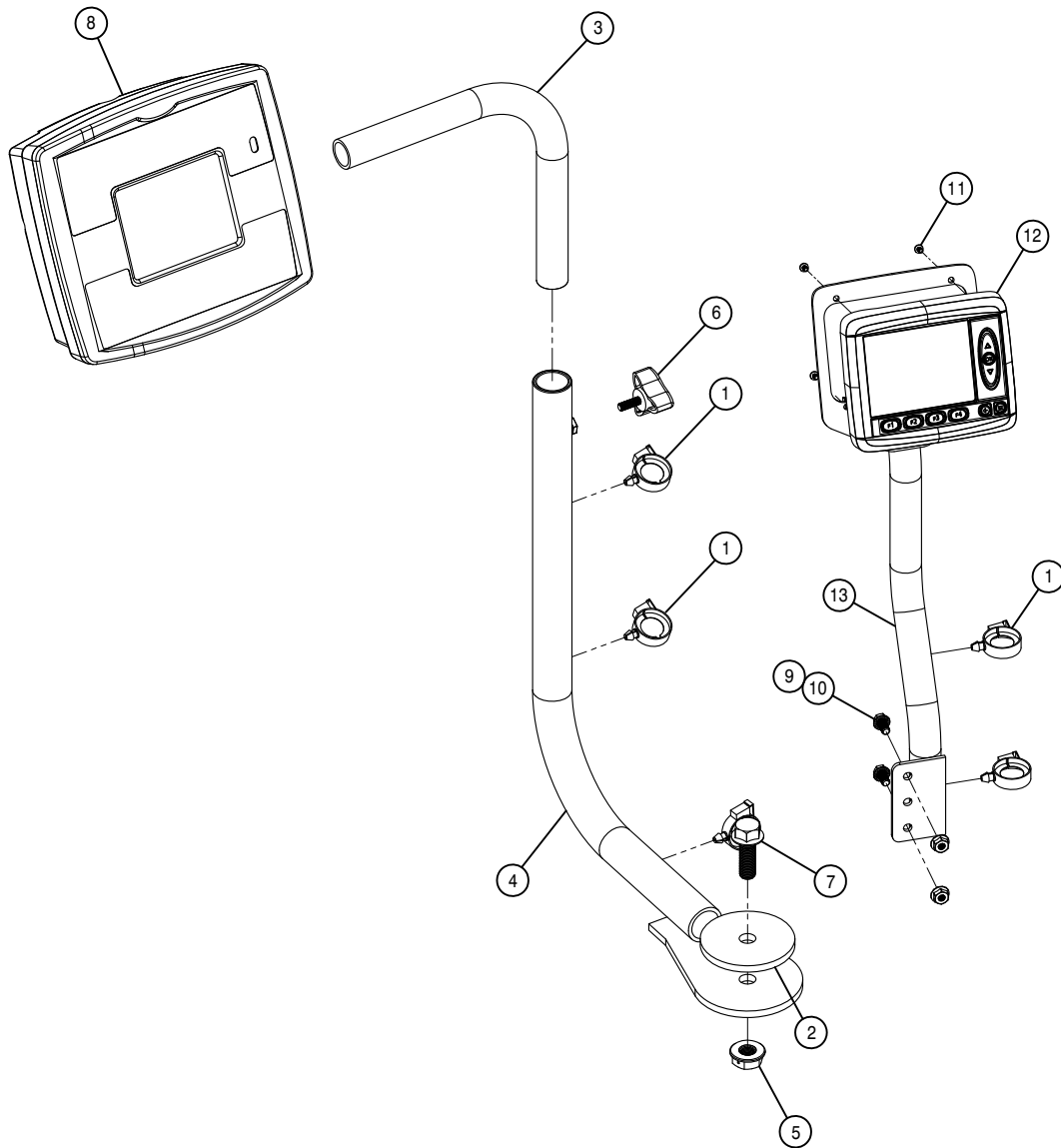

MONITOR ASSEMBLY

DET. QTY PART NO. DESCRIPTION

1	6	291007	ROSEBUD CLIP FOR .750 CONDUIT
2	1	343415	WASHER,3.00 X .531 X .25T UHMW
3	1	343416	MONITOR MT TUBE, STS 05
4	1	343417	MONITOR MT WELD, STS CAB 05
5	1	470345	1/2UNC HEX SMTH FLNG LOCK NUT
6	1	470392	KNOB,3-BLADE BLK,1/4-20 X 3/4
7	1	470431	1/2UNC X 1 1/2 FLANGE LOCK
8	1	690986	CONSOLE, RAVEN SCS 4600
9	2	470121	1/4UNC HEX FLANGE LOCK NUT
10	2	470122	1/4UNC X 1/2 FLANGE HEX BOLT
11	4	903836	8-32X1/4 PHIL PAN MACH SCR
12	1	292008	MD3 MASTER MODULE & DISPLAY
13	1	343678	MD3 DISPLAY MT WLD,STS '10

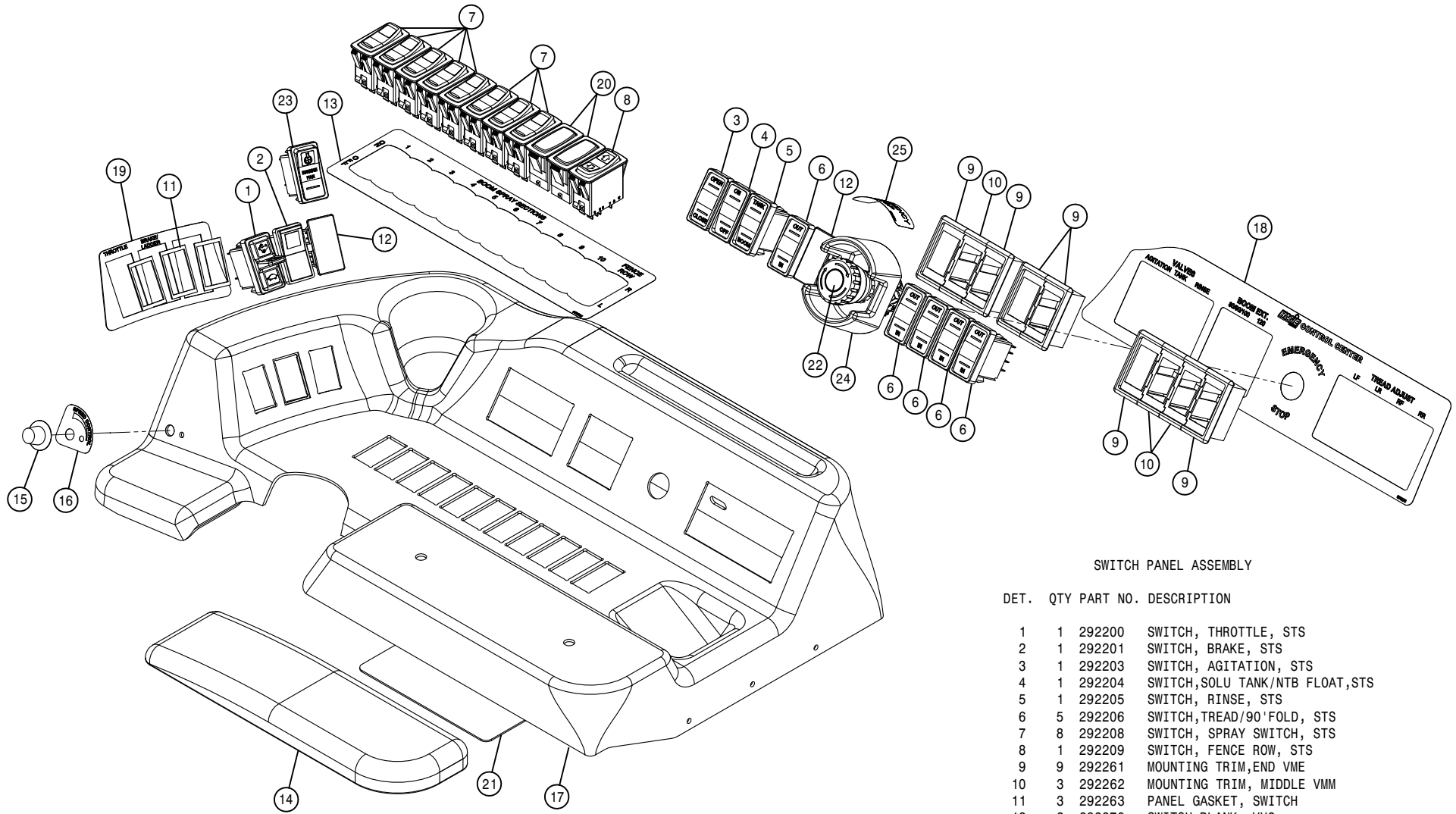

SWITCH PANEL ASSEMBLY

DET.	QTY	PART NO.	DESCRIPTION
	1	292200	SWITCH, THROTTLE, STS
	2	292201	SWITCH, BRAKE, STS
	3	292203	SWITCH, AGITATION, STS
	4	292204	SWITCH, SOLU TANK/NTB FLOAT, STS
	5	292205	SWITCH, RINSE, STS
	6	292206	SWITCH, TREAD/90' FOLD, STS
	7	292208	SWITCH, SPRAY SWITCH, STS
	8	292209	SWITCH, FENCE ROW, STS
	9	292261	MOUNTING TRIM, END VME
	10	292262	MOUNTING TRIM, MIDDLE VMM
	11	292263	PANEL GASKET, SWITCH
	12	292270	SWITCH BLANK, VH2
	13	650225	DECAL, SPRAY SELECT, 10 SECT '10
	14	343397	ARM REST W/MTS, STS CAB '05
	15	470395	DIAL KNOB W/ARROW FOR .25 SHFT
	16	650158	DECAL, SPEED CONTROL STS CAB 05
	17	343823	SIDE CONSOLE, STS CAB '11
	18	650275	DECAL, CONTROL CENTER, STS '11
	19	650177	DECAL, THROTTLE & BRAKE STS 07
	20	292271	SWITCH BLANK, LH2-01
	21	650230	DECAL, STS CAB MODULE '10
	22	290081	E-STOP SWITCH, LED DPST-1NO/1NC
	23	292222	SWITCH, FAN REVERSING
	24	290089	E-STOP SHROUD
	25	650278	DECAL, E-STOP

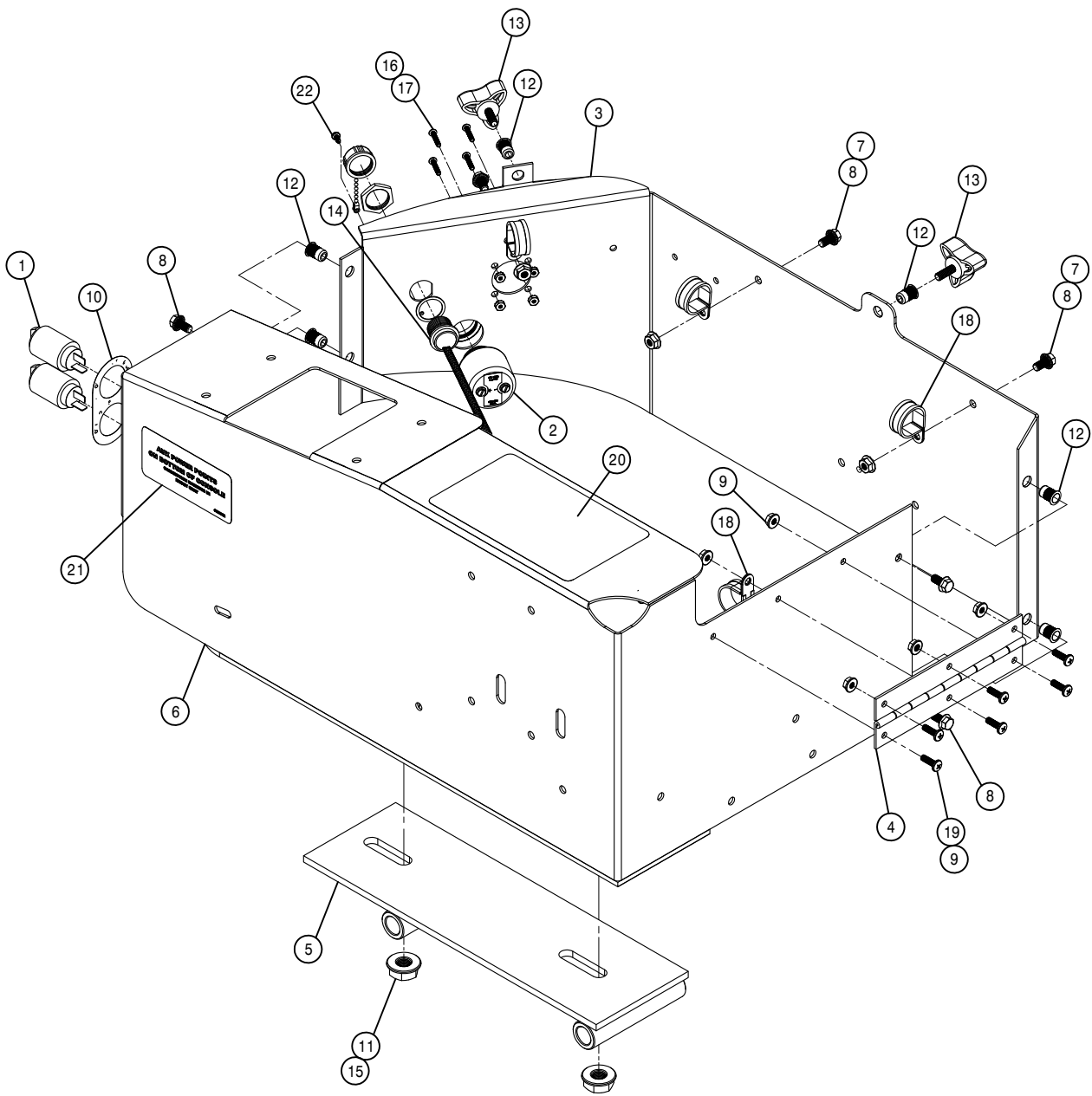

CONSOLE ASSEMBLY

DET.	QTY	PART NO.	DESCRIPTION
1	2	291648	POWER POINT RECEPTACLE
2	1	192502	1 STEEL SPRING GUARD
3	1	343685	SIDE CONSOLE OUTER WRAP,STS' 10
4	1	343405	SIDE CONSOLE REAR HINGE,STS 05
5	1	343406	CONSOLE SEAT BASE WLD,STS 05
6	1	343682	CONSOLE WELD, STS CAB ' 10
7	3	470121	1/4UNC HEX FLANGE LOCK NUT
8	7	470122	1/4UNC X 1/2 FLANGE HEX BOLT
9	6	470175	10-32 HEX FLANGE LOCK NUT
10	1	650163	DECAL,POWER POINT, STS CAB 05
11	2	470345	1/2UNC HEX SMTH FLNG LOCK NUT
12	6	470380	1/4-20 NUTSERT .027-.165 STL
13	2	470392	KNOB,3-BLADE BLK,1/4-20 X 3/4
14	1	293903	HARNES, USB
15	2	470431	1/2UNC X 1 1/2 FLANGE BOLT
16	4	470467	6-32 KEP NUT
17	4	903814	6-32 X 3/4 PHIL PAN MACH SCR
18	4	520101	CUSH CLAMP,#16 1"D X 1/2W
19	6	903710	10-32X5/8 PHIL PANHD MACH SCR
20	1	650276	DECAL,CONSOLE FUSE-RELY STS' 11
21	1	650232	DECAL,AUX PWR POINTS SIGN ' 10
22	1	473932	6-32 X 3/8 PAN SELF TAP SCR

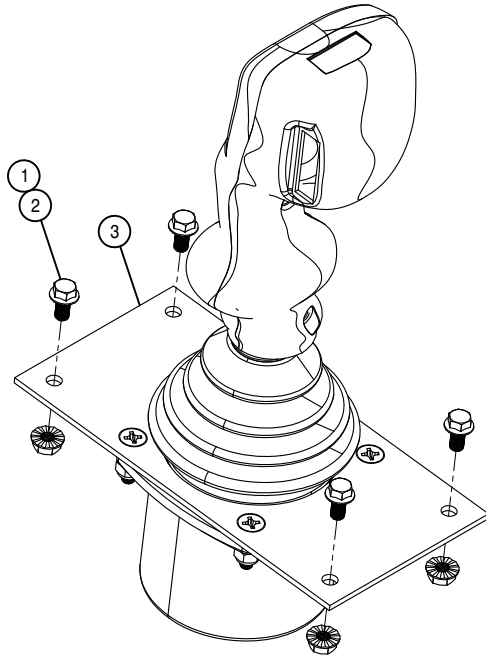

HYDROSTATIC LEVER ASSEMBLY

DET. QTY PART NO. DESCRIPTION

1	4	470121	1/4UNC HEX FLANGE LOCK NUT
2	4	470122	1/4UNC X 1/2 FLANGE HEX BOLT
3	1	785092	CONTROL HANDLE, STS '10

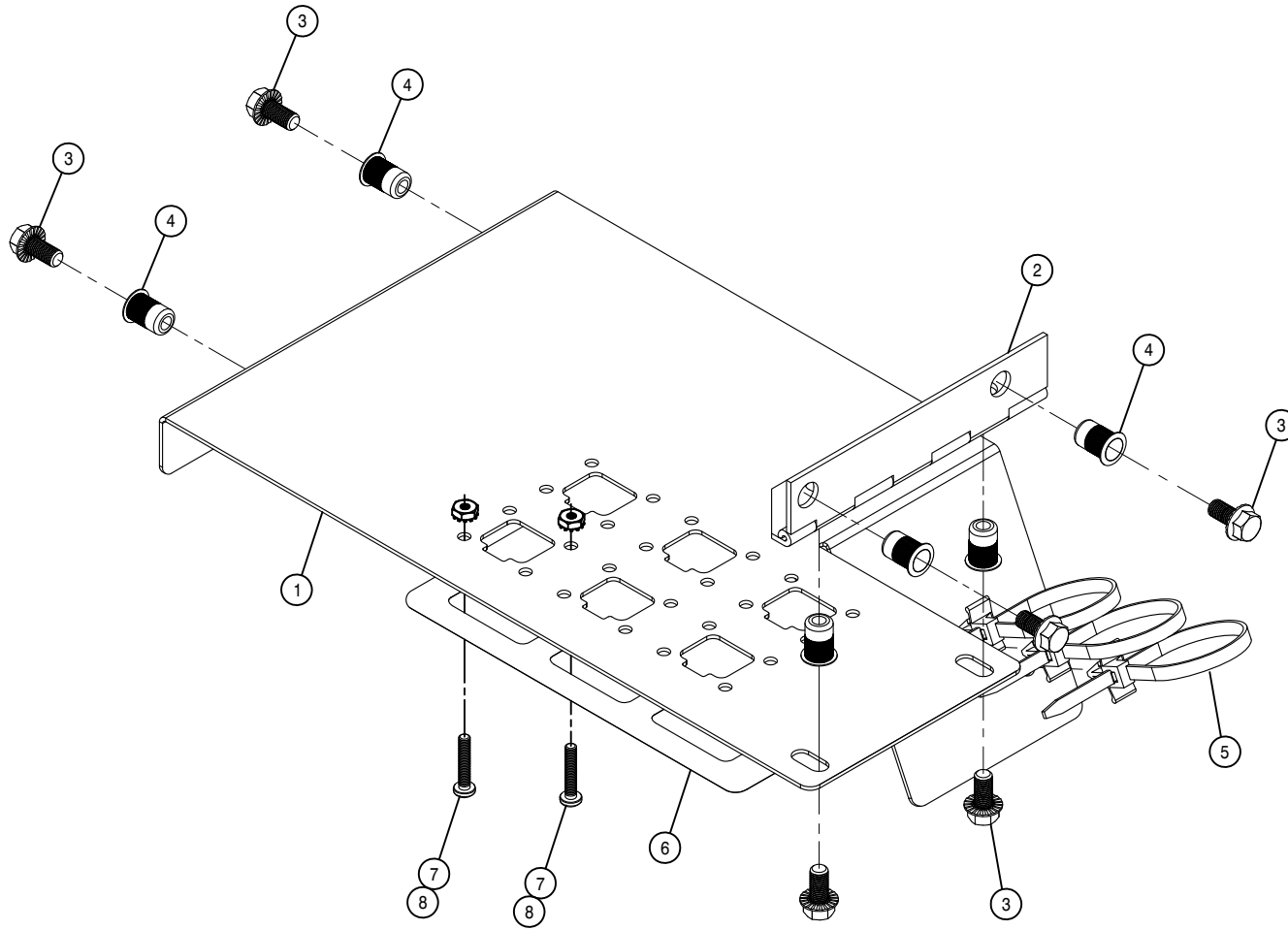

TERMINAL STRIP DOOR ASSEMBLY

DET. QTY PART NO. DESCRIPTION

1	1	343688	CONSOLE BOTTOM DOOR,CAB STS'10
2	1	343414	CONSOLE BTM DOOR HINGE,CAB STS
3	6	470122	1/4UNC X 1/2 FLANGE HEX BOLT
4	6	470380	1/4-20 NUTSERT .027-.165 STL
5	3	470445	CABLE TIE,PUSH MT 7.8" BLK NYL
6	1	650231	DECAL,AUX POWER POINTS '10
7	12	903814	6-32 X 3/4 PHIL PAN MACH SCR
8	12	470467	6-32 KEP NUT

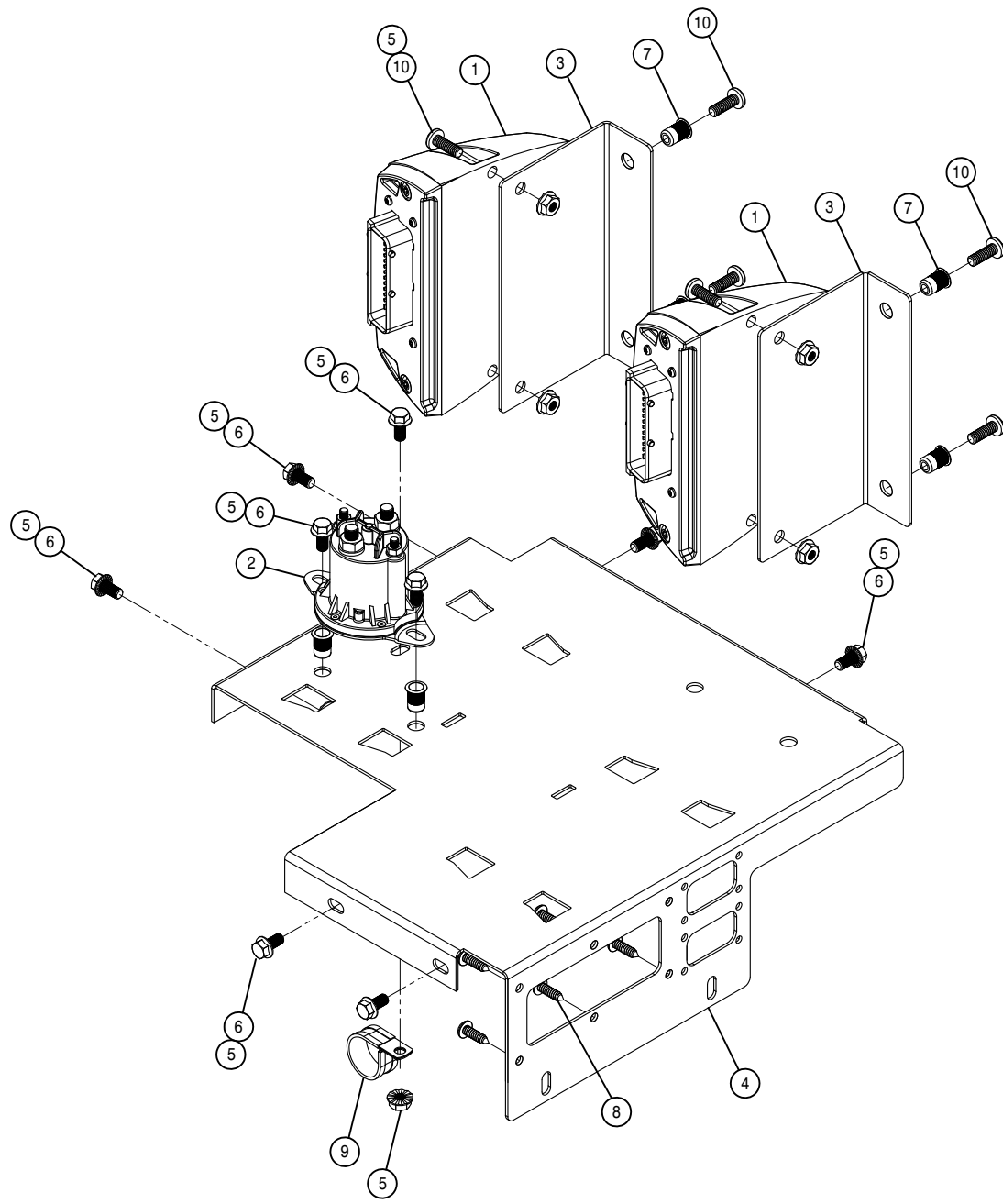

MODULE MOUNT ASSEMBLY

DET.	QTY	PART NO.	DESCRIPTION
	1	292017	IQAN-XS2 MODULE
	2	292505	MASTER CONTROL RELAY
	3	343686	MODULE MT BRKT, STS '10
	4	343687	MODULE MT, CAB CONSOLE STS '10
	5	11 470121	1/4UNC HEX FLANGE LOCK NUT
	6	9 470122	1/4UNC X 1/2 FLANGE HEX BOLT
	7	6 470380	1/4-20 NUTSERT .027- .165 STL
	8	6 470465	#12 X 3/4 PHIL PAN SHT MTL SCR
	9	1 520101	CUSH CLAMP,#16 1"D X 1/2W
	10	8 903700	1/4UNC X 3/4 PHIL PAN MACH SCR

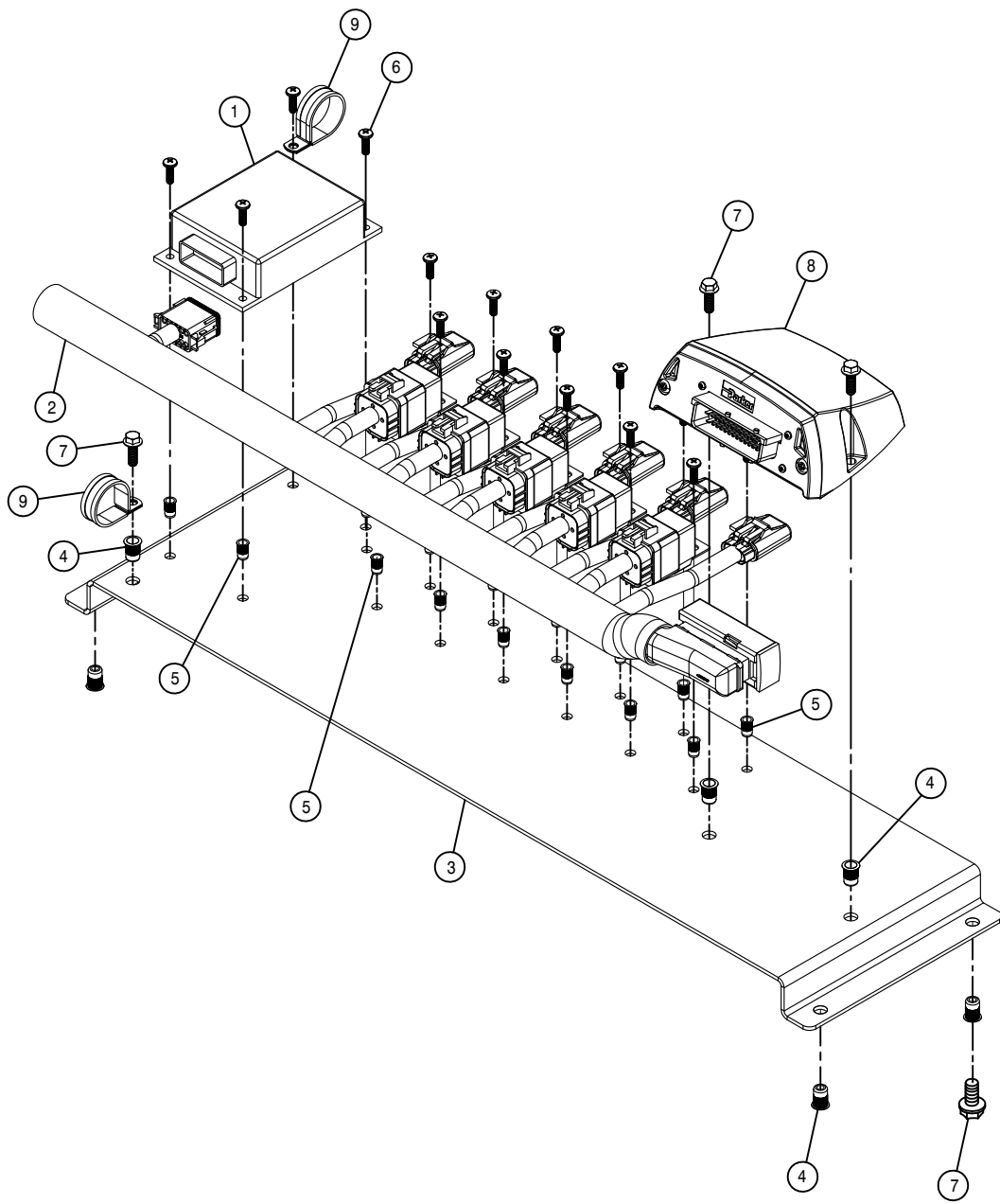

FLASHER AND LIGHT RELAY PANEL

DET. QTY PART NO. DESCRIPTION

1	1	291910	FLASHER, SOLID STATE, 12V
2	1	293926	FUSE/RELY/FLSHR HARNESS, STS' 10
3	1	343692	FLASHER/LIGHT RELAY PNL STS' 10
4	7	470380	1/4-20 NUTSERT .027-.165 STL
5	17	470384	10-32 NUTSERT .020-.130 STL
6	15	903710	10-32X5/8 PHIL PANHD MACH SCR
7	7	470118	1/4UNC X 3/4 FLANGE HEX BOLT
8	1	292017	IQAN-XS2 MODULE
9	2	520102	CUSH CLAMP,#20 1 1/4D X 1/2W

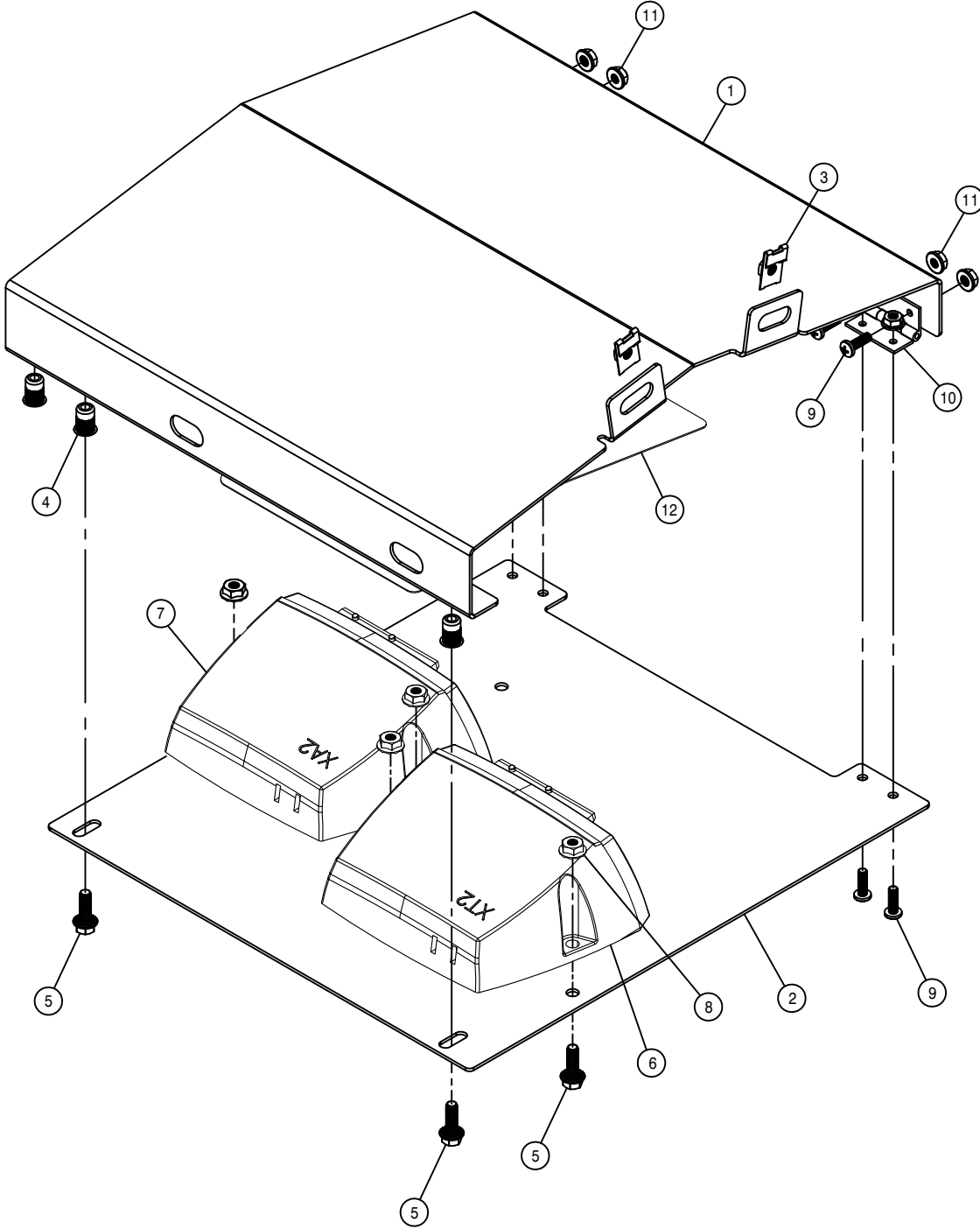

REAR ELECTRICAL BOX ASSEMBLY

DET. QTY PART NO. DESCRIPTION

1	1	343577	TOP LH REAR ELECT BOX, STS 06
2	1	343578	BOT LH REAR ELECT BOX, STS 06
3	2	470218	1/4UNC NUT J-TYPE CAGE CLIP
4	4	470380	1/4-20 NUTSERT .027-.165 STL
5	6	470118	1/4UNC X 3/4 FLANGE HEX BOLT
6	1	292014	IQAN-XT2 TRANSMISSION MODULE
7	1	292016	IQAN-XA2 MODULE
8	4	470121	1/4UNC HEX FLANGE LOCK NUT
9	8	903710	10-32X5/8 PHIL PANHD MACH SCR
10	2	470198	HINGE 146-035
11	8	470175	10-32 HEX FLANGE LOCK NUT
12	1	650235	DECAL,REAR CHASSIS MOD,STS '10

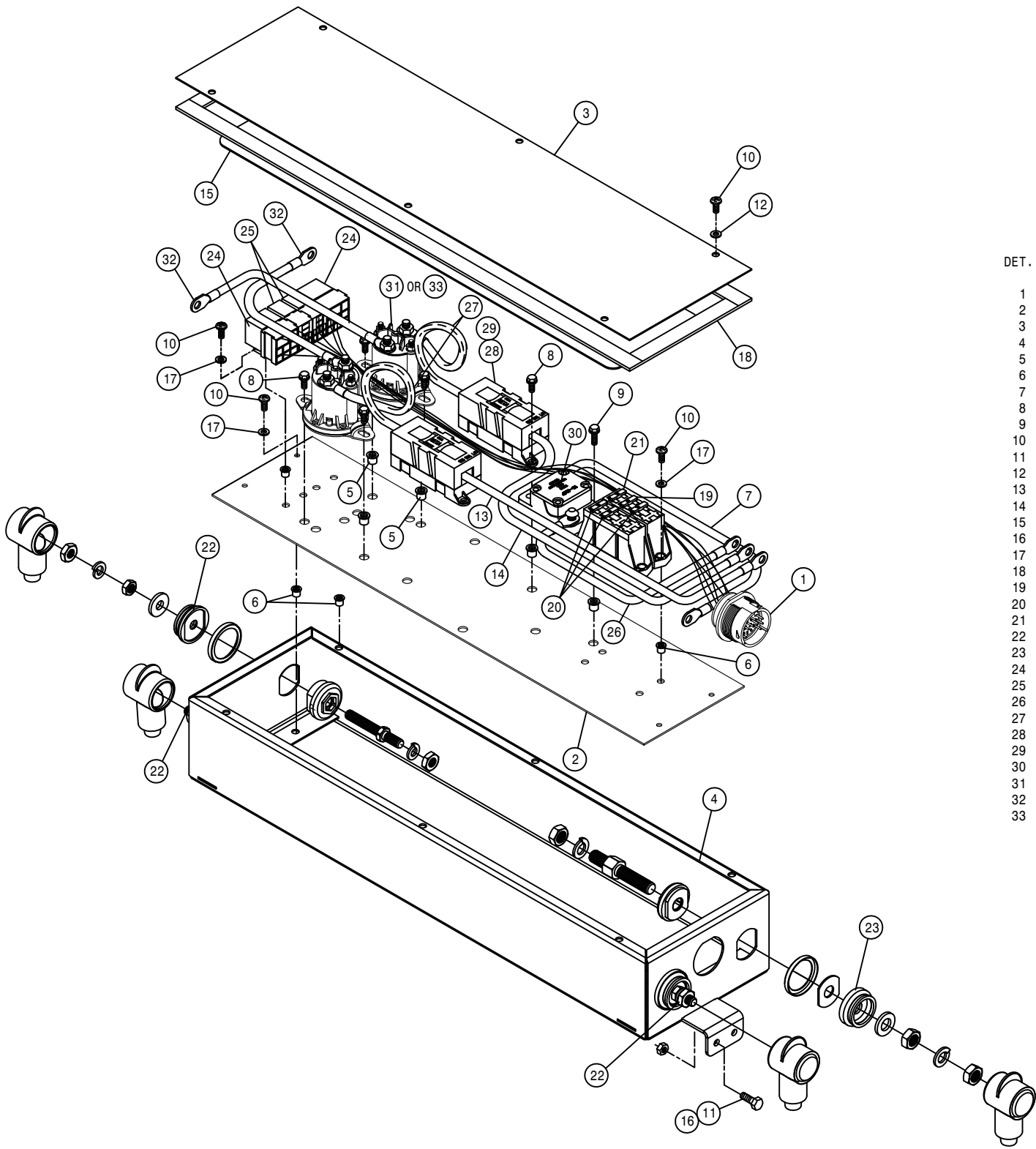

ENGINE ELECTRICAL BOX ASSEMBLY

DET.	QTY	PART NO.	DESCRIPTION
			'10
1	1	293936	ENG ELECT BOX HARNESS, STS
2	1	342960	ENG BOX MT PANEL, STS
3	1	342961	ENG BOX COVER, STS
4	1	343703	ENG BOX WLD, STS
5	10	470380	1/4-20 NUTSERT .027-.165 STL
6	18	470384	10-32 NUTSERT .020-.130 STL
7	1	292538	BATT CABLE, RED 15"6GA 281-406
8	8	470122	1/4UNC X 1/2 FLANGE HEX BOLT
9	2	470118	1/4UNC X 3/4 FLANGE HEX BOLT
10	18	903710	10-32X5/8 PHIL PANHD MACH SCR
11	4	900002	1/4UNC X 3/4 HEX BOLT
12	6	470351	#10 X 1/2 BONDED SEALING WASH
13	1	292539	BATT CABLE, RED 15"6GA 343-531
14	1	292540	BATT CABLE, RED 19"6GA 343-531
15	1	650232	DECAL, AUX PWR POINTS SIGN
16	4	914000	1/4UNC HEX STOVER NUT
17	12	920510	#10 LOCK WASHER
18	5.5	193037	STICKERTITE 1/8 X 3/4
19	1	291549	30 AMP FUSE, LED 1/4" BLADE, ATC
20	3	291546	15 AMP FUSE, LED 1/4" BLADE, ATC
21	1	291547	20 AMP FUSE, LED 1/4" BLADE, ATC
22	3	291343	POWER BUSHING, 3/8" RED WTHRPRF
23	1	291344	POWER BUSHING, 1/2" RED WTHRPRF
24	2	291751	RELAY, SPDT, BKT MT, DIODE, 5T
25	2	291781	MICRO RELAY, BOSCH 12V SPDT
26	1	292537	BATT CABLE, RED 12"6GA 281-531
27	2	291806	BATT CABLE, RED 11"6GA. 343-.343
28	2	291813	FUSE, 125 AMP 32V DC
29	2	291814	FUSE HOLDER, HIGH AMP
30	1	292501	CIRCUIT BREAKER, 120 AMP, BUSS
31	2	291816	SOLENOID, 4-TERMINAL STS
32	2	292536	BATT CABLE, RED 10"6GA 343-406
33	1	292505	MASTER CONTROL RELAY

09

508060

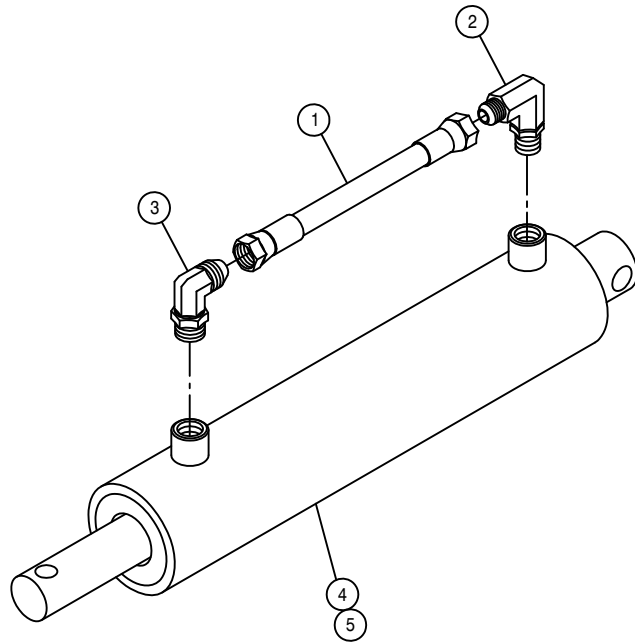

HOOD HYDRAULIC CYLINDER ASSEMBLY

DET. QTY PART NO. DESCRIPTION

1	1	616246	04-451TC-06FJX-06FJX-10	H/A
2	1	618119	9/16MJIC-90-9/16MOR LBO	
3	1	618689	9/16MJ-90-9/16MOR .042 CHK VLV	
4	1	621530	HYD CYL, 2.00 X 6.00 X 1.000	
5	1	621531	SUB>621521:KIT, HYD CYL 621530	

NOTE: 1. 621077 - HOOD HYDRAULIC CYLINDER ASSEMBLY

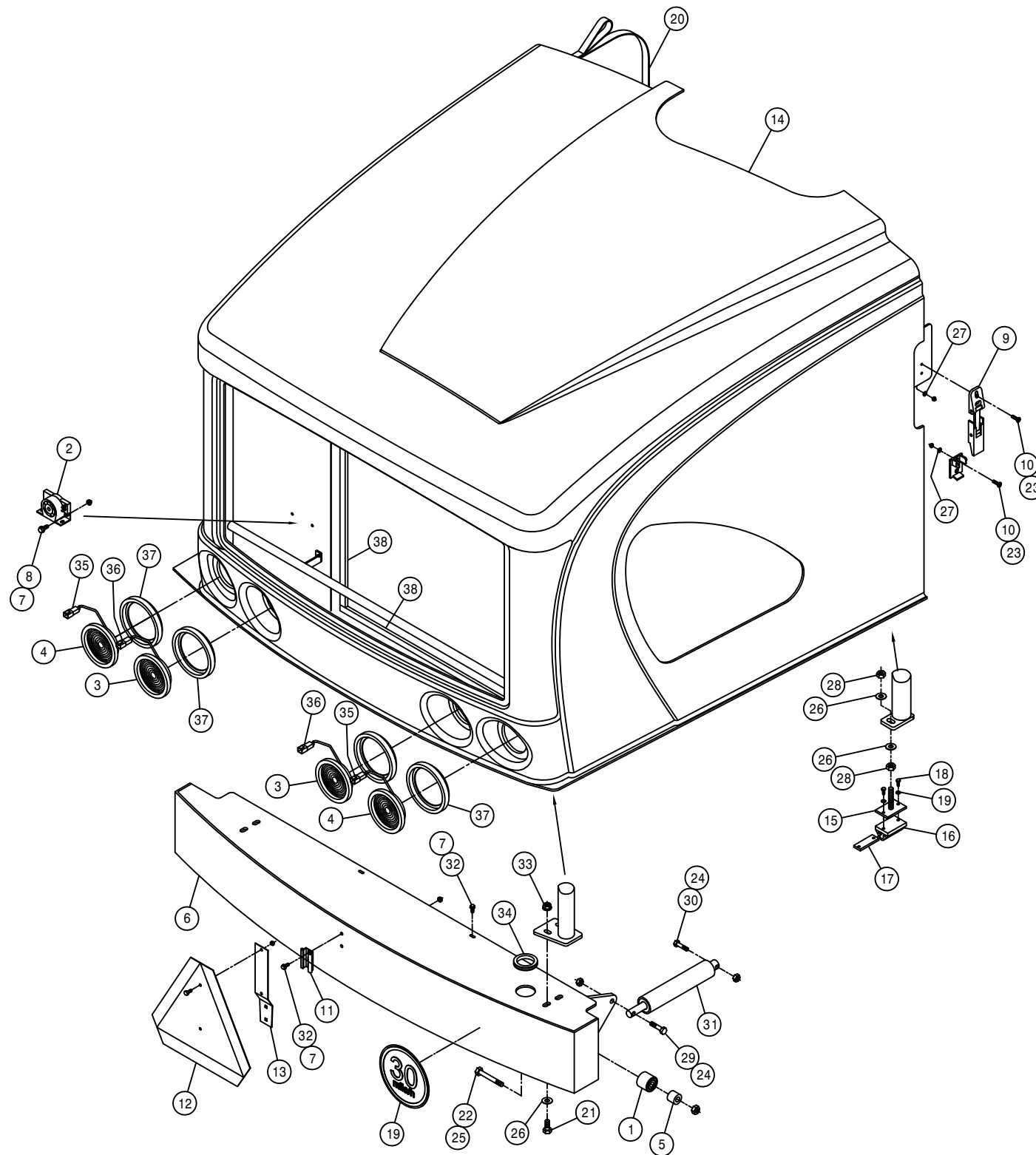

BUMPER AND REAR HOOD ASSEMBLY

DET.	QTY	PART NO.	DESCRIPTION
	2	125056	TRACK ROLLER,2.00 OD, .625 BORE
	1	290061	ALARM,BACKUP 107DBA LT DUTY
	2	290201	RED LED STT 3 DIODE LAMP
	2	290200	AMBER LED STT 3 DIODE LAMP
	2	361679	BUMPER PIVOT BRG SPACER,STS 04
	1	361680	REAR BUMPER WLD, STS 04
	6	470121	1/4UNC HEX FLANGE LOCK NUT
	2	470122	1/4UNC X 1/2 FLANGE HEX BOLT
	2	470368	LATCH W/KEEPER, FLEXIBLE LEVER
	8	903710	10-32X5/8 PHIL PANHD MACH SCR
	1	472251	MTG SOCKET FOR 472249 SMV SIGN
	1	472249	SLOW MOVING VEHICLE SIGN, SMV
	1	472250	SPADE MTG BRKT FOR 472249 SMV
	1	660222	REAR ENGINE HOOD, STS 04
	2	660224	ENG HOOD BUMPER WLD, STS 04
	2	660226	ENG HOOD BUMPER, STS 04
	2	660227	ENG HOOD BUMPER KEEPER, STS 04
	4	900003	1/4UNC X 1" HEX BOLT
	1	650223	DECAL,30MPH ID SYMBOL, VINYL
	1	660230	ENG HOOD PULL STRAP ASSY,STS04
	4	900265	1/2UNC X 1 1/2 HEX BOLT
	2	900341	5/8UNC X 3 3/4 HEX BOLT
	8	910027	10-32 HEX NUT
	2	473007	1/2UNC HEX NUT, NYLOC
	2	914010	5/8UNC HEX STOVER NUT
	8	920004	1/2 SAE FLAT WASHER
	8	920510	#10 LOCK WASHER
	4	910008	1/2UNC HEX NUT
	1	900267	1/2UNC X 2" HEX BOLT
	1	900268	1/2UNC X 2 1/2 HEX BOLT
	1	621077	HOOD HYD CYL ASSY, STS 04
	4	470118	1/4UNC X 3/4 FLANGE HEX BOLT
	4	470360	1/2UNC HEX FLANGE LOCK NUT
	1	470441	GROMMET, .500ID .250GW 2.190GD
	2	290202	2-WIRE PIGTAIL FOR 290200AMBER
	2	290203	3-WIRE PIGTAIL FOR 290201 RED
	4	290204	4" GROMMET FOR 290200 & 290201
	2	193066	FOAM,1" X 1.5 X 81"ADHVE STRIP

FRONT PANEL AND DOOR ASSEMBLY

DET. QTY PART NO. DESCRIPTION

DET.	QTY	PART NO.	DESCRIPTION	C/L
1	1	340330	.375 SCH40 BP X 1.25	C/L
2	4	470075	COTTER PIN 1/8 X 3/4	
3	4	470118	1/4UNC X 3/4 FLANGE HEX BOLT	
4	7	470121	1/4UNC HEX FLANGE LOCK NUT	
5	5	470122	1/4UNC X 1/2 FLANGE HEX BOLT	
6	1	470306	DOOR LATCH, RH TWO-ROTOR	
7	1	470325	7/16UNC HEX FLANGE LOCK NUT	
8	6	470335	LINCHPIN, 3/16 X 1 1/4 GRIP	
9	2	470367	FLAT HINGE, 180 DEG, DIECAST	
10	1	472324	ROLL PIN, 5/32 X 1/2	
11	2	900064	5/16UNC X 3/4 HEX BOLT	
12	4	660244	DOOR HINGE BRKT WLD STS LS	06
13	1	660246	FRT BELLY SHILD, STSLS	06
14	1	660247	REAR BELLY SHIELD, STSLS	06
15	1	660231	LWR ENG COVER, STS	04
16	1	660238	FRT ENG HOOD BRACE, STS10/12	07
17	1	660220	FRONT ENGINE HOOD, STS	04
18	1	660221	AIR CLEANER DOOR, STS	04
19	1	660228	SIDE DOOR LATCH EXT, STS	04
20	2	660229	DOOR HINGE BACK PLATE, STS	04
21	2	900005	1/4UNC X 1 1/2 HEX BOLT	
22	4	900050	1/4UNC X 1 1/4 PH LHLD MAC SCR	
23	2	900277	1/2UNC X 5 1/2 HEX BOLT	
24	1	900216	7/16UNC X 2 1/2 HEX BOLT	
25	2	900265	1/2UNC X 1 1/2 HEX BOLT	
26	4	914000	1/4UNC HEX STOVER NUT	
27	2	914002	5/16UNC HEX STOVER NUT	
28	2	920001	5/16 SAE FLAT WASHER	
29	1	920003	7/16 SAE FLAT WASHER	
30	2	920004	1/2 SAE FLAT WASHER	
31	4	470360	1/2UNC HEX FLANGE LOCK NUT	
32	8	470233	5/16UNC X 3/4 FLANGE HEX BOLT	
33	8	470113	5/16UNC HEX FLANGE LOCK NUT	

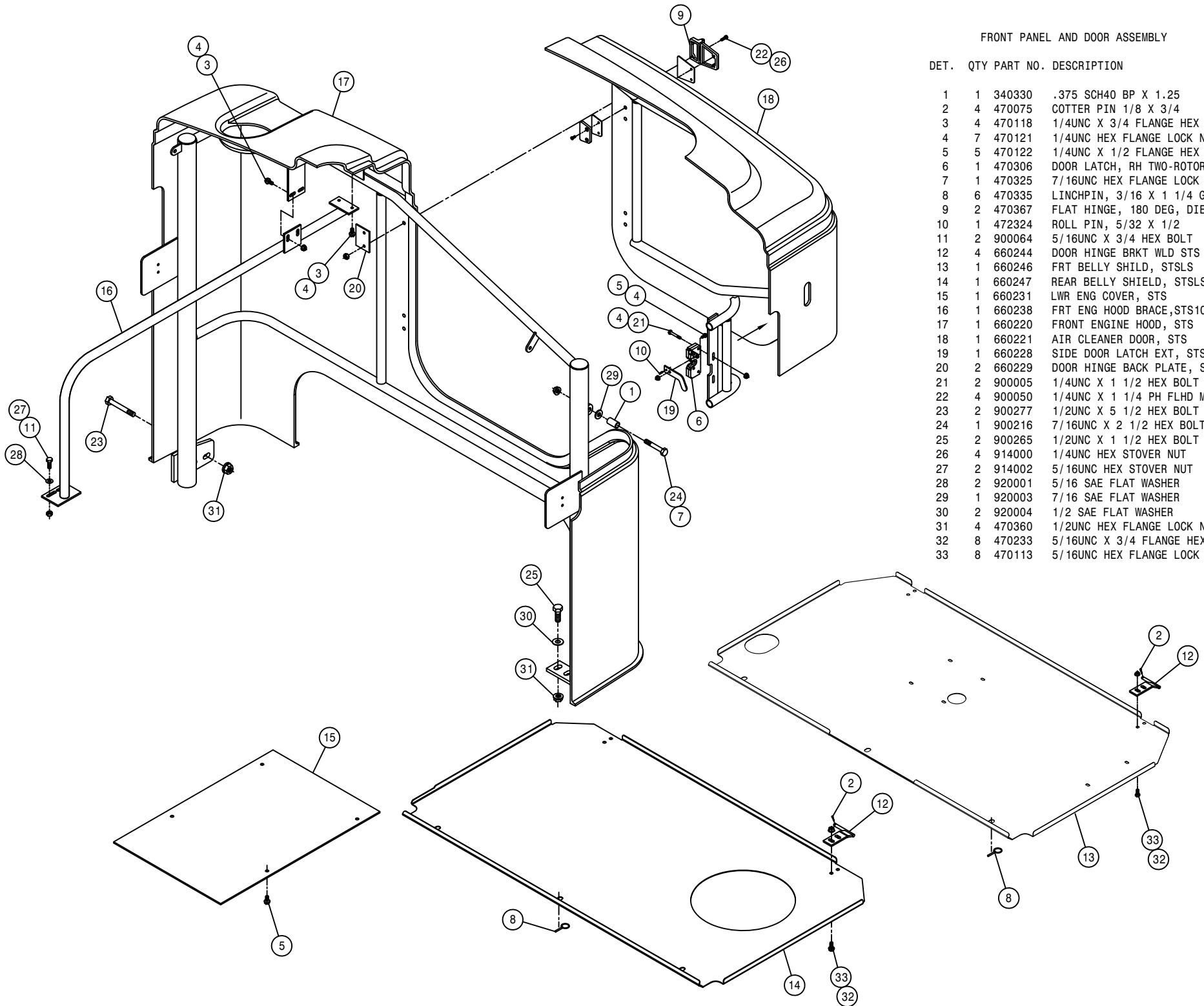

POLY RINSE TANK ASSEMBLY

DET. QTY PART NO. DESCRIPTION

1	5	500024	1"NPT-90-1"HOSE BARB, POLY
2	1	500063	1"NPT PIPE PLUG, POLY
3	1	763740	100 GAL POLY TANK, GRAY '11
4	1	763590	POLY RINSE TANK MT WLD STS12
5	1	763594	POLY RINSE TANK MT PAD STS12
6	2	763595	POLY RINSE TNK STRAP ASSY STS
7	2	900392	1/2UNC X 1 1/2 SOCKET CAP SCR
8	4	914008	1/2UNC HEX STOVER NUT
9	2	920004	1/2 SAE FLAT WASHER
10	2	500157	1" FLANGE GASKET EPDM
11	2	500159	1" FLANGE CLAMP, S.S.
12	1	500163	1" FLANGE-1" MNPT ADPTR POLY
13	1	500173	1" FLANGE-90-1" HOSE BARB POLY
14	1	505198	SS PIPE NIPPLE 1.00NPT-3.00
15	1	690660	LINE T-STRAINER,1"FLG,W/O SCR
16	1	690669	100 MESH SCREEN FOR 690660
17	1	696004	BALL VLV,1.00NP 3WAY-SIDE POLY
18	5	520090	HOSE CLAMP NO 16 STAINLESS
19	1	601522	HOSE, 1 X 204 1BR BLK EPDM
20	1	601556	HOSE, 1 X 48 1BR BLK EPDM
21	1	601725	HOSE, 1 X 225 1BR BLK EPDM
22	1	601391	HOSE, 1 X 274 1BR BLK EPDM
23	1	701155	8" LID FOR 5 GAL TANK 701085
24	1	601742	HOSE, 1" X 16 CLEAR VINYL
25	1	763623	GREEN POLYPROPYLENE BALL .750"
26	2	500107	1"NPT SWIVEL POLY

NOTE * FRONT FILL OPTION
 ** SIDE FILL OPTION

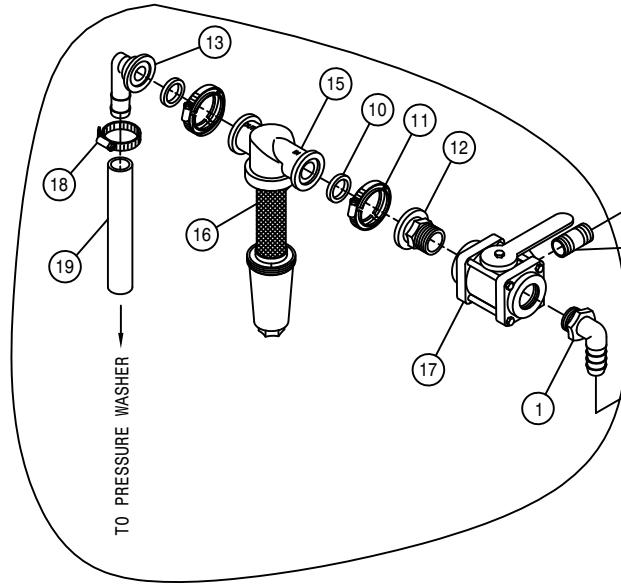

PRESSURE WASHER OPTION

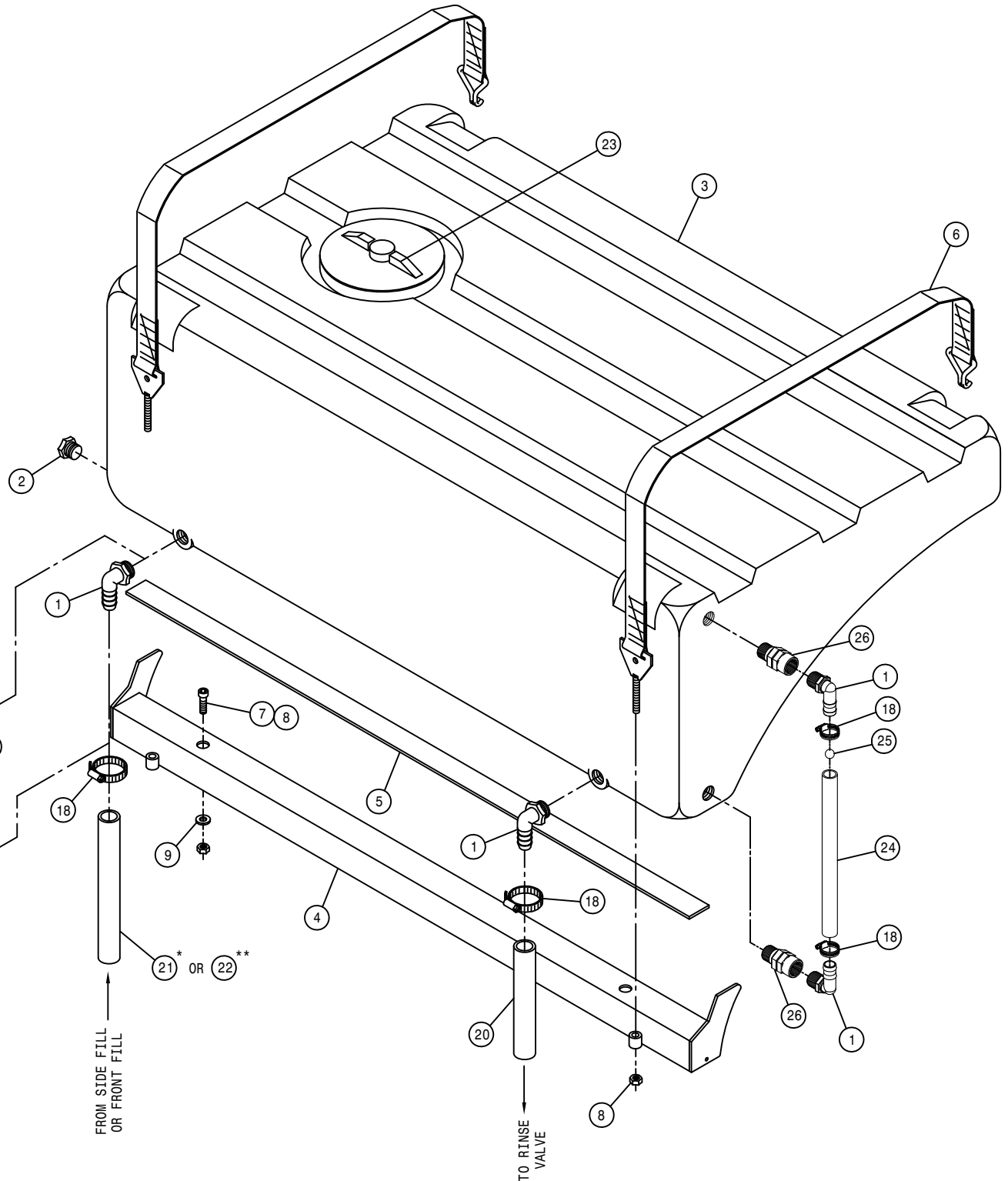

1400 GALLON SS TANK ASSEMBLY

DET. QTY PART NO. DESCRIPTION

1	1	500063	1" NPT PIPE PLUG, POLY
2	1	500047	1/2 NPT-90-1/2 HOSE BARB, POLY
3	1	500104	1/4 NPT-90-1/4 HOSE BARB, POLY
4	5	500157	1" FLANGE GASKET EPDM
5	3	500158	1 1/2" GASKET FOR 2" FLANGE
6	5	500159	1" FLANGE CLAMP, S.S.
7	3	500160	2" FLANGE CLAMP, S.S.
8	1	500171	1" FLANGE-1" HOSE BARB POLY
9	1	500175	1" FLANGE TEE POLY
10	3	470118	1/4 UNC X 3/4 FLANGE HEX BOLT
11	4	500194	2" FP FLANGE CLAMP, S.S.
12	4	500195	2" FP FLANGE GASKET EPDM
13	1	500197	2" FP FLANGE-90-1 1/2 HBARB
14	1	500226	1" FLANGE PLUG W/1/4" FNPT POLY
15	1	500238	1" FLANGE PLUG W/1/2" FNPT POLY
16	1	507103	PIPE CAP, 2.00 FNPT S.S.
17	1	520067	HOSE CLAMP NO 28 STAINLESS
18	1	520070	HOSE CLAMP NO 8 STAINLESS
19	2	520090	HOSE CLAMP NO 16 STAINLESS
20	1	520120	HOSE CLAMP NO 4 STAINLESS
21	1	601705	HOSE, 1 X 170 1BR BLK EPDM
22	3	470121	1/4 UNC HEX FLANGE LOCK NUT
23	1	601706	HOSE, 1 1/2 X 60 2BR BLK EPDM
24	1	601643	HOSE, 1/2 X 286 1BR BLK EPDM
25	1	601674	HOSE, 1/4 X 120 1 BR BLK EPDM
26	1	763727	1400 GAL SS TANK '11
27	7	500208	3" FLANGE CLAMP, S.S.
28	7	500209	3" FLANGE GASKET EPDM
29	3	500210	3" FLANGE-3" HOSE BARB POLY
30	2	500213	3" FLANGE-90-3" FLANGE LBO POLY
31	1	696149	BALL VLV, 3" FLANGE
32	2	500164	3" FLANGE-3" MNPT ADPTR POLY
33	1	696268	VALVE, 3" KZCO
34	1	500196	2" FP FLANGE-2" HOSE BARB POLY
35	1	500212	3" FLANGE-2" FP FLANGE REDU POLY
36	1	500219	2" FP FLANGE-90-2" FP FLANGE LBO
37	1	696258	VALVE, KZCO C2I-60B-Y19
38	1	601573	HOSE, 2 X 48 2F-1W EPDM
39	1	601663	HOSE, 3 X 50 POLY HELIX EPDM
40	1	520141	2.31/2.62 T-BOLT HOSE CLAMP SS
41	6	520145	3.56/3.88 T-BOLT HOSE CLAMP SS
42	1	500211	3" FLANGE-90-3" HOSE BARB POLY
43	1	601508	HOSE, 3 X 64 POLY HELIX EPDM
44	1	601680	HOSE, 3 X 91 POLY HELIX EPDM
45	1	601574	HOSE, 3 X 36 POLY HELIX EPDM
46	1	601645	HOSE, 3 X 94 POLY HELIX EPDM
47	1	690731	SOLU TUBE, 3.00 S.S. SIDE FILL
48	2	900064	5/16 UNC X 3/4 HEX BOLT
49	2	914002	5/16 UNC HEX STOVER NUT
50	1	470422	IND BELT, 4.00 X 93.00 .203THK
51	1	763738	SIGHT GAUGE TUBE, STS '11
52	4	482016	SPRING, 1.40 X 3.00 COMPRSN
53	4	900416	3/4 UNC X 6 1/2 HEX BOLT
54	4	914012	3/4 UNC HEX STOVER NUT
55	8	920006	3/4 SAE FLAT WASHER
56	1	763561	LID ASSY FOR 763550 TANK
57	1	763562	10" FILL LID SEAL FOR 763550
58	1	763563	16" MANHOLE SEAL FOR 763550
59	1	500024	1" NPT-90-1" HOSE BARB, POLY
60	1	601682	HOSE, 1 X 111 2BR BLK EPDM
61	1	500054	3/4 NPT-90-3/4 HOSE BARB, POLY
62	1	500150	2" FLANGE-1" BRANCH TEE POLY
63	1	500154	2" FLANGE-2" HOSE BARB POLY
64	1	500180	2" FLANGE-90-2" FLANGE LBO, LONG
65	1	500185	1" FLANGE-90-3/4" HOSE BARB POLY
66	4	520055	HOSE CLAMP NO 12 STAINLESS
67	1	520068	HOSE CLAMP NO 32 STAINLESS
68	1	601529	HOSE, 3/4 X 34 CLEAR VINYL
69	1	601728	HOSE, 3/4 X 60 CLEAR VINYL
70	1	601743	HOSE, 2 X 113 2F-1W EPDM
71	2	650144	DECAL, LOGO, SOLU TANK STS12
72	1	650264	DECAL, 1400G SS SIGHT GAUGE '11
73	1	343759	SIGHT GAUGE SUPP, STS '11
74	3	470572	1.31ID U-BOLT HUB CLAMP
75	2	500067	1 NPT-90-3/4 HOSE BARB, POLY
76	2	504212	1" SCH80 SOCKT X 1" NPT ADPT, PVC
77	1	763623	GREEN POLYPROPYLENE BALL .750"
78	1	316783	HOSE SUPPORT, STS16/GST20 07
79	2	470113	5/16 UNC HEX FLANGE LOCK NUT
80	2	470234	5/16 UNC X 1" FLANGE HEX BOLT
81	1	193012	QUICKEDGE TRIM .135 TO .250

NOTE: ITEMS (*) ARE USED WITH THE SIDE FILL OPTION
 ITEMS (**) ARE USED WITH THE FRONT FILL OPTION

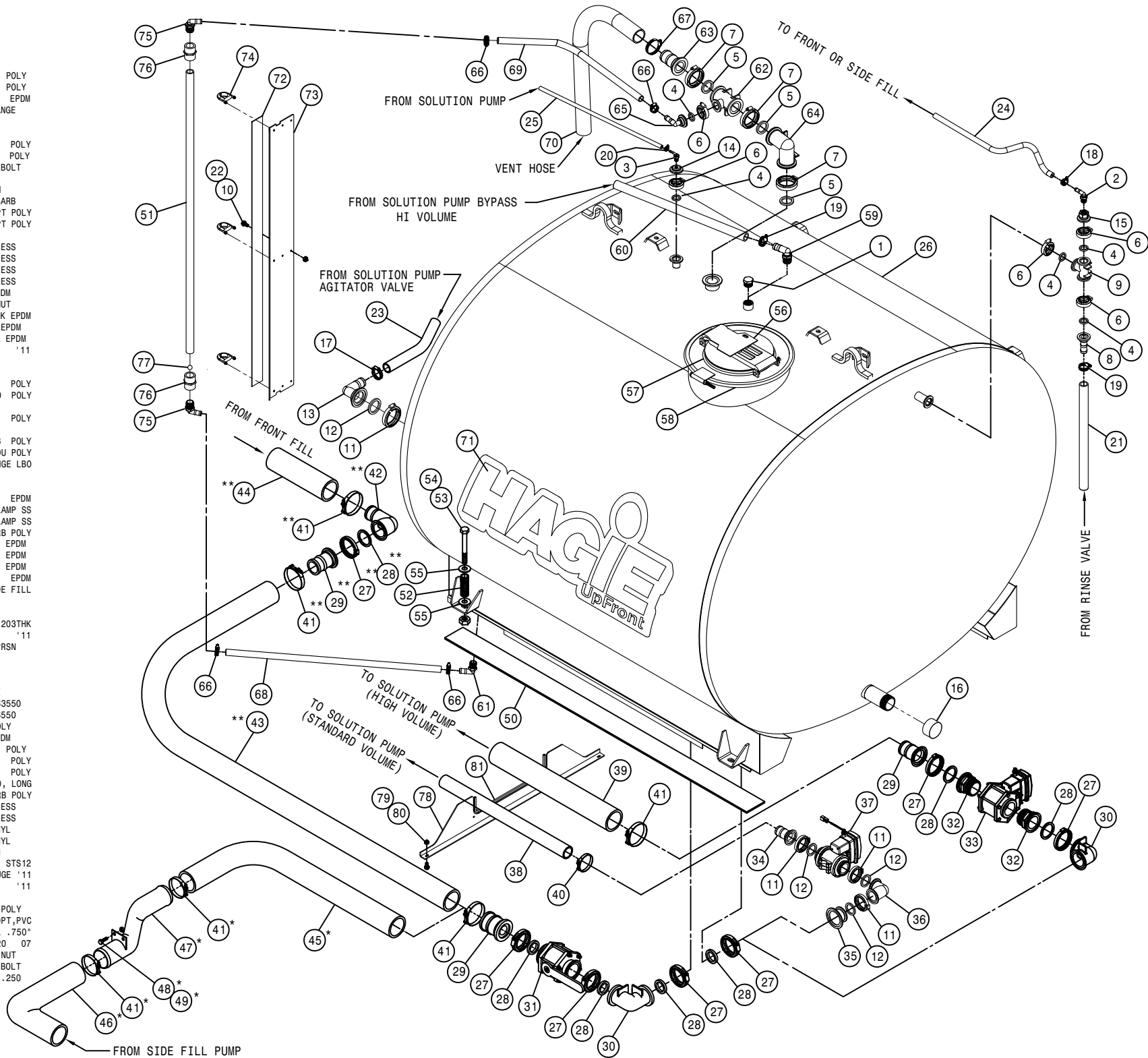

QUICK COUPLER ASSEMBLY

DET. QTY PART NO. DESCRIPTION

1	1	500154	2" FLANGE-2" HOSE BARB	POLY
2	3	500158	1 1/2" GASKET FOR 2" FLANGE	
3	3	500160	2" FLANGE CLAMP, S.S.	
4	1	500180	2"FLANGE-90-2"FLANGE LBO	POLY
5	1	500225	2"FLANGE-45-2"FLANGE LBO	POLY
6	1	500152	2" FLANGE-2" MNPT ADPTR	POLY
7	1	690391	2.00FNPT-MALE COUPLER	POLY
8	1	601628	HOSE, 2 X 51 2F-1W EPDM	
9	2	520141	2.31/2.62 T-BOLT HOSE CLAMP SS	
10	1	690392	PLUG FOR 2.00 FEMALE COUPLER	
11	1	690272	2" FEM COUPLER W/LOCK, 2" BARB	
12	1	690623	CAP FOR 2.00 MALE COUPLER POLY	
13	1	500231	2"FP FLANGE GASKET,EXTRA THICK	
14	2	470322	LANYARD, 8" NYLON LOOP/LOOP	
15	1	520099	HOSE CLAMP NO 40 STAINLESS	

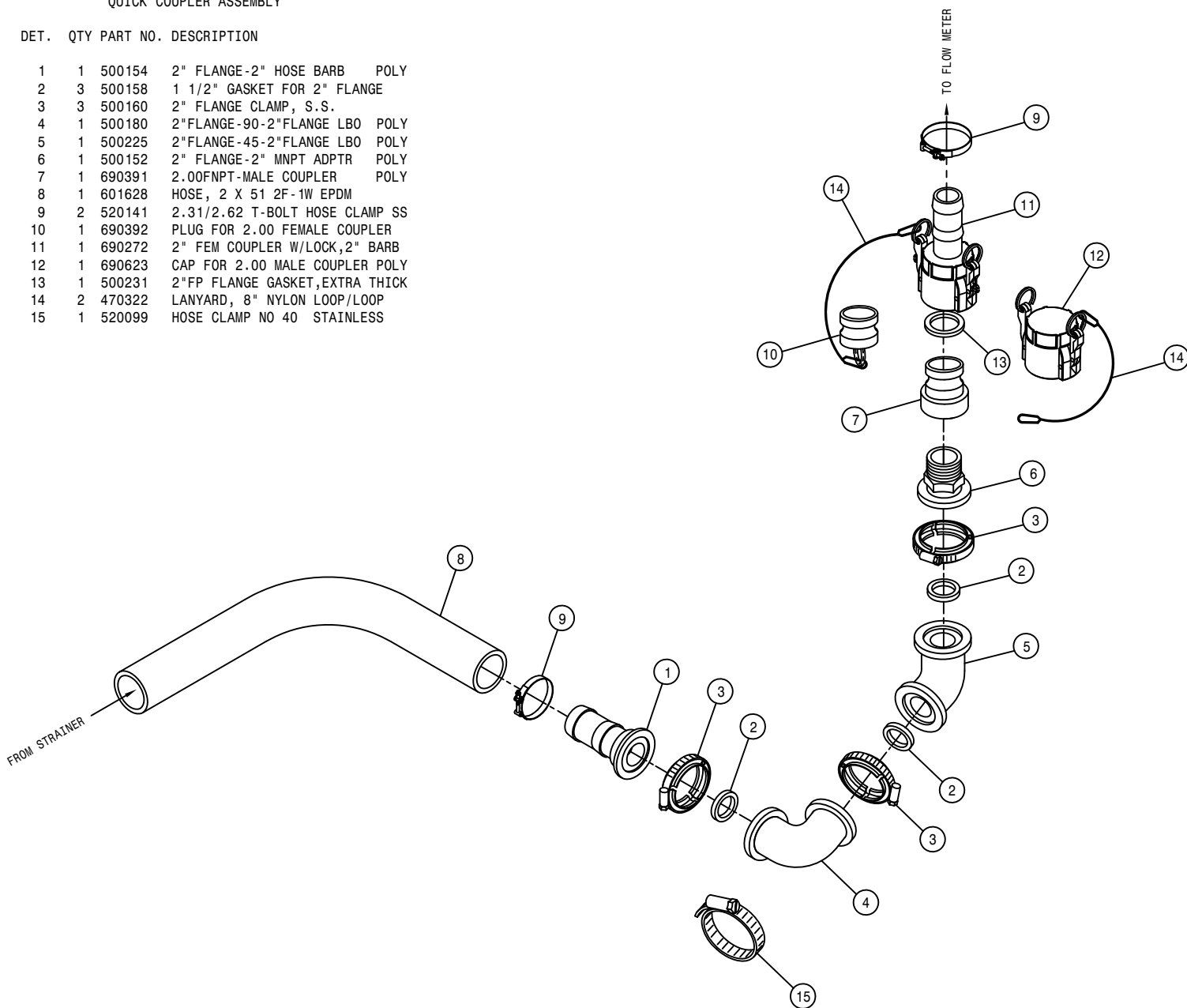

FRONT FILL SOLUTION HOSEING (SV)

DET. QTY PART NO. DESCRIPTION

DET.	QTY	PART NO.	DESCRIPTION
1	1	601705	HOSE, 1 X 170 1BR BLK EPDM
2	1	601674	HOSE, 1/4 X 120 1 BR BLK EPDM
3	1	601743	HOSE, 2 X 113 2F-1W EPDM
4	1	601613	HOSE, 2 X 43 2F-1W EPDM
5	1	601502	HOSE, 2 X 56 2F-1W EPDM
6	1	601643	HOSE, 1/2 X 286 1BR BLK EPDM
7	1	601634	HOSE, 1/2 X 78 1BR BLK EPDM
8	1	601677	HOSE, 1/2 X 100 1BR BLK EPDM
9	1	601573	HOSE, 2 X 48 2F-1W EPDM
10	1	601706	HOSE, 1 1/2 X 60 2BR BLK EPDM
11	1	601590	HOSE, 1 X 6 1BR BLK EPDM
12	1	601628	HOSE, 2 X 51 2F-1W EPDM
13	2	601566	HOSE, 1/2 X 252 1BR BLK EPDM
14	1	601273	HOSE, 1 X 132 1BR BLK EPDM
15	1	601680	HOSE, 3 X 91 POLY HELIX EPDM
16	2	601725	HOSE, 1 X 225 1BR BLK EPDM
17	1	601508	HOSE, 3 X 64 POLY HELIX EPDM
18	1	601521	HOSE, 1 X 72 1BR BLK EPDM
19	1	601522	HOSE, 1 X 204 1BR BLK EPDM
20	1	601523	HOSE, 1 X 300 1BR BLK EPDM
21	1	601524	HOSE, 1 X 396 1BR BLK EPDM
22	2	601525	HOSE, 1 X 84 1BR BLK EPDM
23	1	601529	HOSE, 3/4 X 34 CLEAR VINYL
24	1	601728	HOSE, 3/4 X 60 CLEAR VINYL
25	1	601742	HOSE, 1" X 16 CLEAR VINYL
26	2	601556	HOSE, 1 X 48 1BR BLK EPDM
27	2	601510	HOSE, 1 X 26 1BR BLK EPDM
28	1	601397	HOSE, 1 1/2 X 120 2BR BLK EPDM

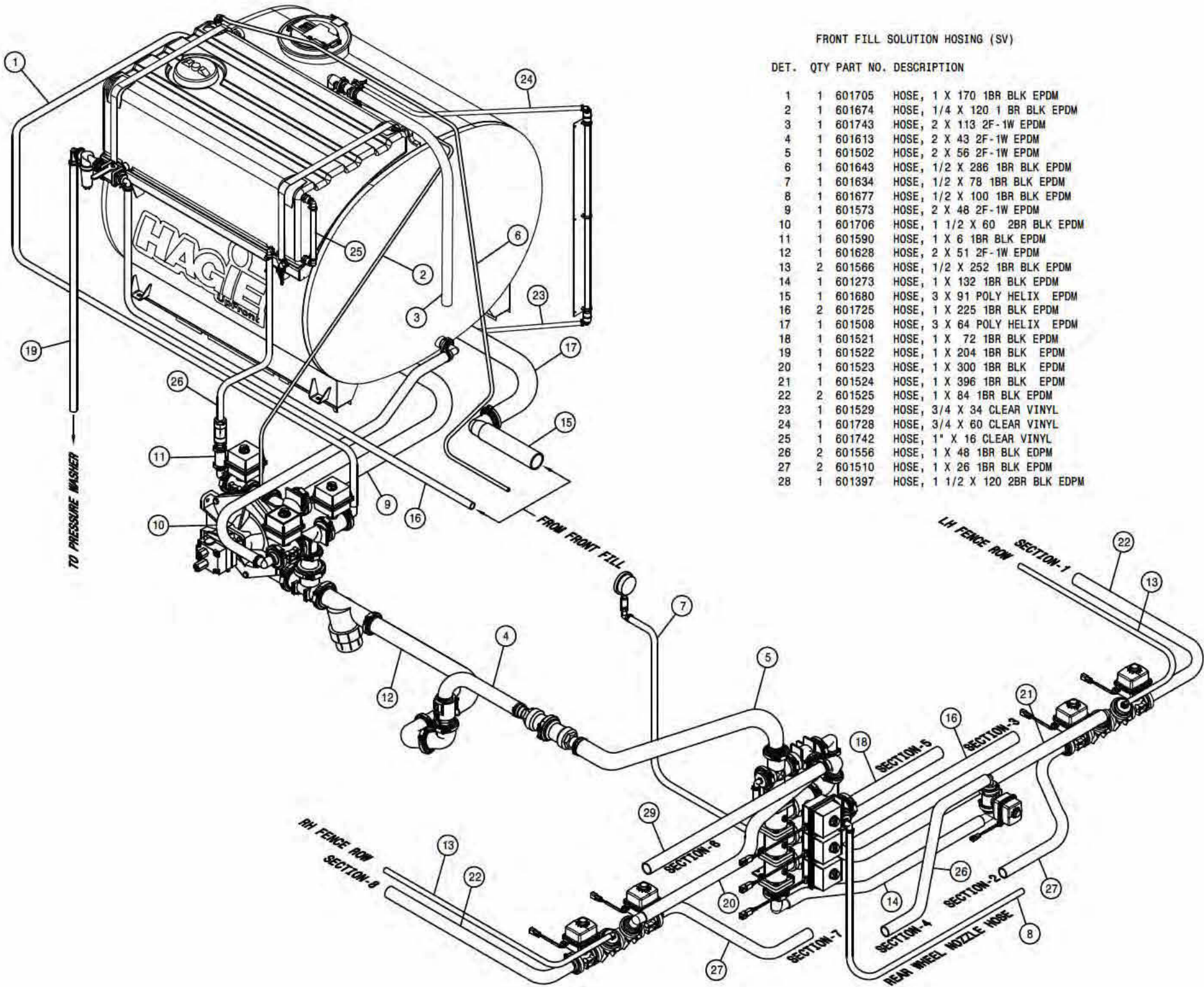

SIDE FILL SOLUTION HOISING (SV)

DET. QTY PART NO. DESCRIPTION

DET.	QTY	PART NO.	DESCRIPTION
1	1	601705	HOSE, 1 X 170 1BR BLK EPDM
2	1	601674	HOSE, 1/4 X 120 1 BR BLK EPDM
3	1	601743	HOSE, 2 X 113 2F-1W EPDM
4	1	601613	HOSE, 2 X 43 2F-1W EPDM
5	1	601502	HOSE, 2 X 56 2F-1W EPDM
6	1	601643	HOSE, 1/2 X 286 1BR BLK EPDM
7	1	601634	HOSE, 1/2 X 78 1BR BLK EPDM
8	1	601677	HOSE, 1/2 X 100 1BR BLK EPDM
9	1	601573	HOSE, 2 X 48 2F-1W EPDM
10	1	601706	HOSE, 1 1/2 X 60 2BR BLK EPDM
11	1	601590	HOSE, 1 X 8 1BR BLK EPDM
12	1	601628	HOSE, 2 X 51 2F-1W EPDM
13	2	601566	HOSE, 1/2 X 252 1BR BLK EPDM
14	1	601725	HOSE, 1 X 225 1BR BLK EPDM
15	2	601525	HOSE, 1 X 84 1BR BLK EPDM
16	1	601645	HOSE, 3 X 94 POLY HELIX EPDM
17	1	601574	HOSE, 3 X 36 POLY HELIX EPDM
18	1	690731	SOLU TUBE, 3.00 S.S. SIDE FILL
19	1	601391	HOSE, 1 X 274 1BR BLK EPDM
20	1	601521	HOSE, 1 X 72 1BR BLK EPDM
21	1	601522	HOSE, 1 X 204 1BR BLK EPDM
22	1	601523	HOSE, 1 X 300 1BR BLK EPDM
23	1	601524	HOSE, 1 X 396 1BR BLK EPDM
24	1	601529	HOSE, 3/4 X 34 CLEAR VINYL
25	1	601728	HOSE, 3/4 X 60 CLEAR VINYL
26	1	601742	HOSE, 1" X 16 CLEAR VINYL
27	2	601556	HOSE, 1 X 48 1BR BLK EDPM
28	1	601510	HOSE, 1 X 26 1BR BLK EPDM
29	1	601397	HOSE, 1 1/2 X 120 2BR BLK EDPM
30	1	601273	HOSE, 1 X 132 1BR BLK EPDM

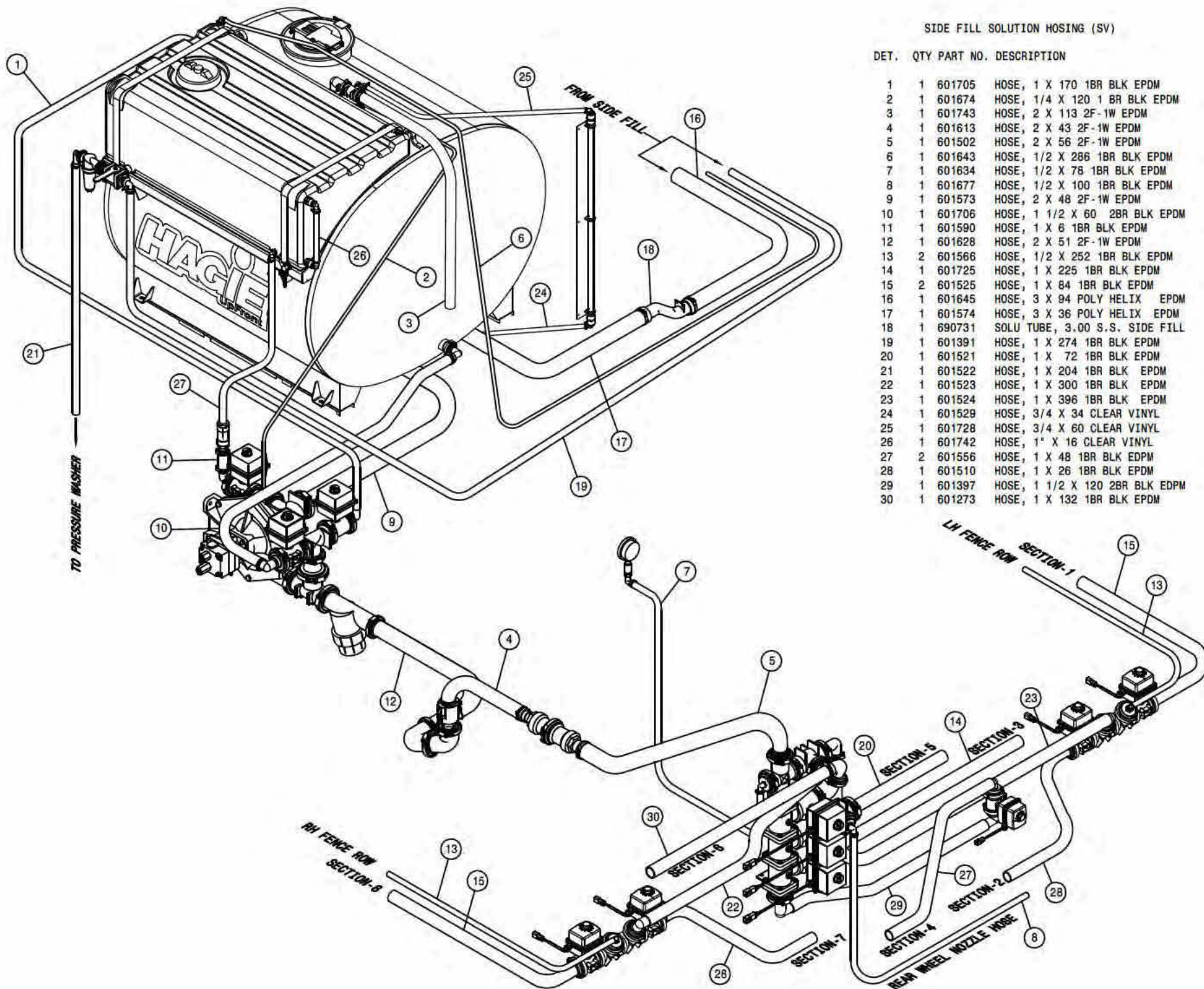

DET. QTY PART NO. DESCRIPTION

DET.	QTY	PART NO.	DESCRIPTION
1	2	500074	1"NPT-1" HOSE BARB, POLY
2	1	500103	1/8NPT-90-1/4 HOSE BARB,NYLON
3	1	500151	2" FLANGE TEE POLY
4	1	500154	2" FLANGE-2" HOSE BARB POLY
5	9	500158	1 1/2" GASKET FOR 2" FLANGE
6	12	500160	2" FLANGE CLAMP, S.S.
7	1	500172	2" FLANGE-1" HOSE BARB POLY
8	3	500180	2"FLANGE-90-2"FLANGE LBO POLY
9	1	500189	2" FLANGE-90-1" HOSE BARB POLY
10	6	500194	2"FP FLANGE CLAMP, S.S.
11	6	500195	2"FP FLANGE GASKET EPDM
12	1	500196	2"FP FLANGE-2" HOSE BARB POLY
13	3	500199	2"FP FLANGE-2"FLANGE REDU POLY
14	2	500207	2"FP FLANGE TEE POLY
15	4	520090	HOSE CLAMP NO 16 STAINLESS
16	1	601590	HOSE, 1 X 6 1BR BLK EPDM
17	2	618191	1 1/16MJ-90-1 1/16FJ SWIV LBO
18	1	618273	1 1/16MJIC-1/2MNPT ADPTR
19	1	650125	DECAL,AGIT RATE IND, KZCO VLV
20	1	690488	1.00 CHECK VLV, SPRING LOADED
21	1	690628	LINE "Y" STRAINER, 2" FLANGE
22	1	690629	50 MESH SCREEN FOR 690628
23	1	691160	HYPRO PUMP,9306G-HMSC-BU,FLG
24	3	696254	O-RING, KZCO FLANGED VALVES
25	2	696256	VALVE, KZCO C2F-60B-M-S9
26	1	696257	VALVE, KZCO C2F-62-Q-S9
27	1	500153	2" FLANGE-90-1 1/2 HBARB POLY
28	1	520067	HOSE CLAMP NO 28 STAINLESS
29	2	520141	2.31/2.62 T-BOLT HOSE CLAMP SS
30	1	520120	HOSE CLAMP NO 4 STAINLESS
31	2	900131	3/8UNC X 1 1/2 HEX BOLT
32	2	914004	3/8UNC HEX STOVER NUT
33	1	690944	SEAL KIT,SILICON HYPRO 690906
34	1	292500	PWM AMPLIFIER,12V
35	2	472235	10-32 X 3/4 PHIL PAN MACH SCR
36	2	470175	10-32 HEX FLANGE LOCK NUT
37	1	618108	1 1/16MJIC-3/4MNPT ADPTR

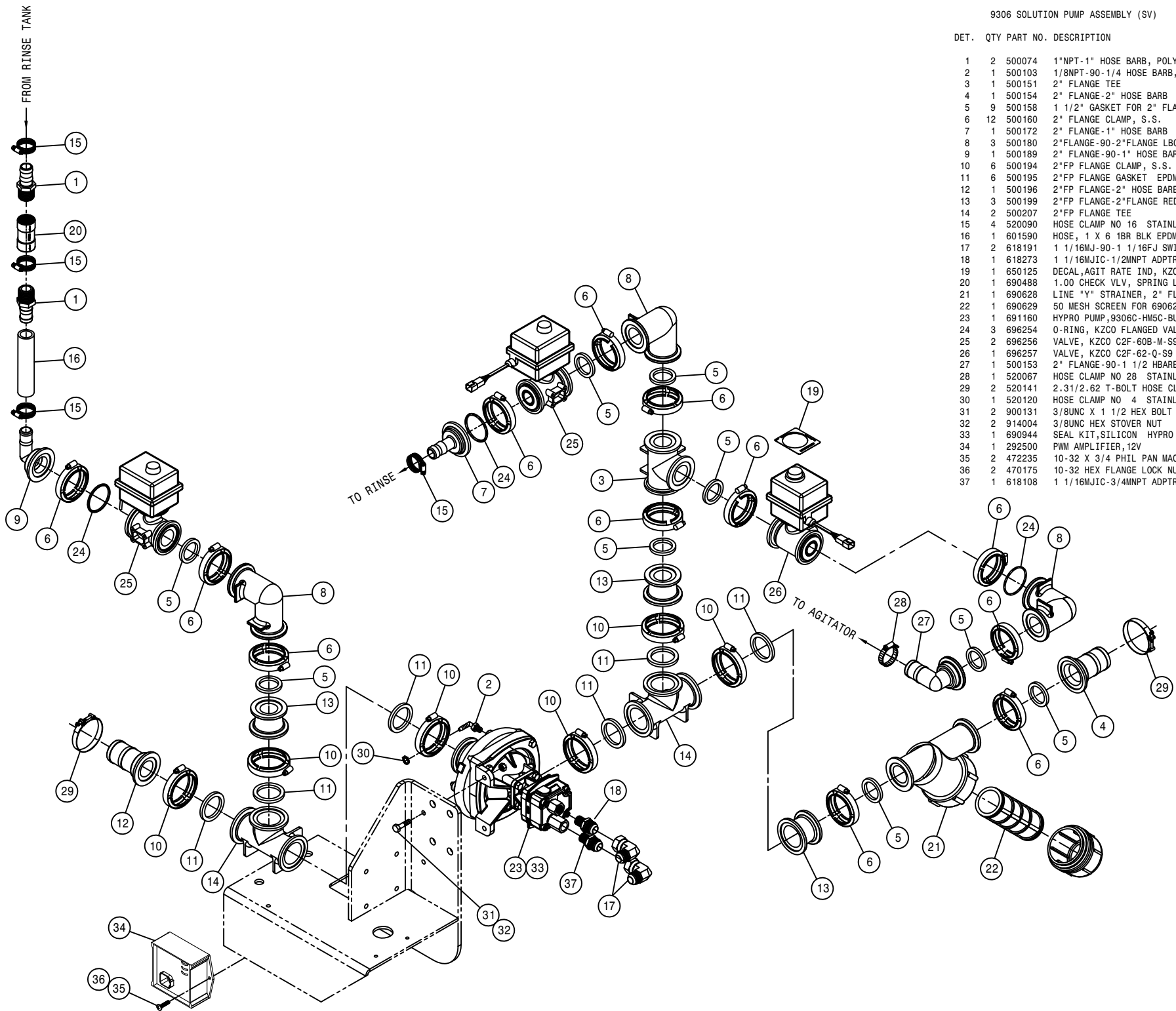

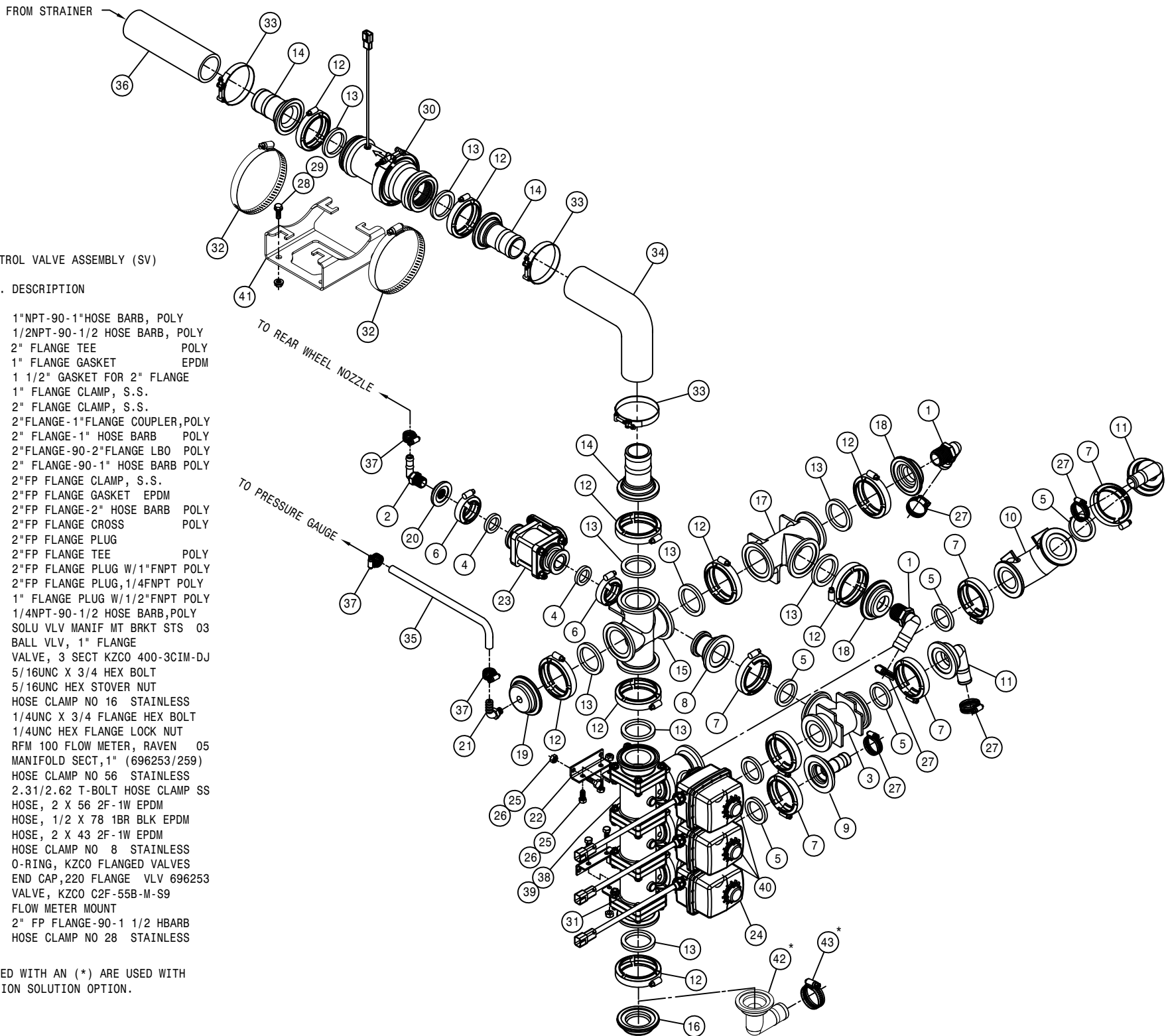

SOLUTION CONTROL VALVE ASSEMBLY (SV)

DET. QTY PART NO. DESCRIPTION

1	2	500024	1"NPT-90-1"HOSE BARB, POLY
2	1	500047	1/2NPT-90-1/2 HOSE BARB, POLY
3	1	500151	2" FLANGE TEE POLY
4	2	500157	1" FLANGE GASKET EPDM
5	6	500158	1 1/2" GASKET FOR 2" FLANGE
6	2	500159	1" FLANGE CLAMP, S.S.
7	6	500160	2" FLANGE CLAMP, S.S.
8	1	500161	2"FLANGE-1"FLANGE COUPLER,POLY
9	1	500172	2" FLANGE-1" HOSE BARB POLY
10	1	500180	2"FLANGE-90-2"FLANGE LBO POLY
11	2	500189	2" FLANGE-90-1" HOSE BARB POLY
12	9	500194	2"FP FLANGE CLAMP, S.S.
13	9	500195	2"FP FLANGE GASKET EPDM
14	3	500196	2"FP FLANGE-2" HOSE BARB POLY
15	1	500203	2"FP FLANGE CROSS POLY
16	1	500206	2"FP FLANGE PLUG
17	1	500207	2"FP FLANGE TEE POLY
18	2	500228	2"FP FLANGE PLUG W/1"FNPT POLY
19	1	500229	2"FP FLANGE PLUG,1/4FNPT POLY
20	1	500238	1" FLANGE PLUG W/1/2"FNPT POLY
21	1	618556	1/4NPT-90-1/2 HOSE BARB,POLY
22	2	690870	SOLU VLV MANIF MT BRKT STS 03
23	1	696147	BALL VLV, 1" FLANGE
24	1	696259	VALVE, 3 SECT KZCO 400-3CIM-DJ
25	8	900064	5/16UNC X 3/4 HEX BOLT
26	8	914002	5/16UNC HEX STOVER NUT
27	5	520090	HOSE CLAMP NO 16 STAINLESS
28	2	470118	1/4UNC X 3/4 FLANGE HEX BOLT
29	2	470121	1/4UNC HEX FLANGE LOCK NUT
30	1	690961	RFM 100 FLOW METER, RAVEN 05
31	3	696269	MANIFOLD SECT,1" (696253/259)
32	2	520056	HOSE CLAMP NO 56 STAINLESS
33	3	520141	2.31/2.62 T-BOLT HOSE CLAMP SS
34	1	601502	HOSE, 2 X 56 2F-1W EPDM
35	1	601634	HOSE, 1/2 X 78 1BR BLK EPDM
36	1	601613	HOSE, 2 X 43 2F-1W EPDM
37	3	520070	HOSE CLAMP NO 8 STAINLESS
38	7	696254	O-RING, KZCO FLANGED VALVES
39	2	696255	END CAP,220 FLANGE VLV 696253
40	3	696260	VALVE, KZCO C2F-55B-M-S9
41	1	691089	FLOW METER MOUNT
42	1	500197	2" FP FLANGE-90-1 1/2 HBARB
43	1	520067	HOSE CLAMP NO 28 STAINLESS

NOTE: ITEMS MARKED WITH AN (*) ARE USED WITH THE 8-SECTION SOLUTION OPTION.

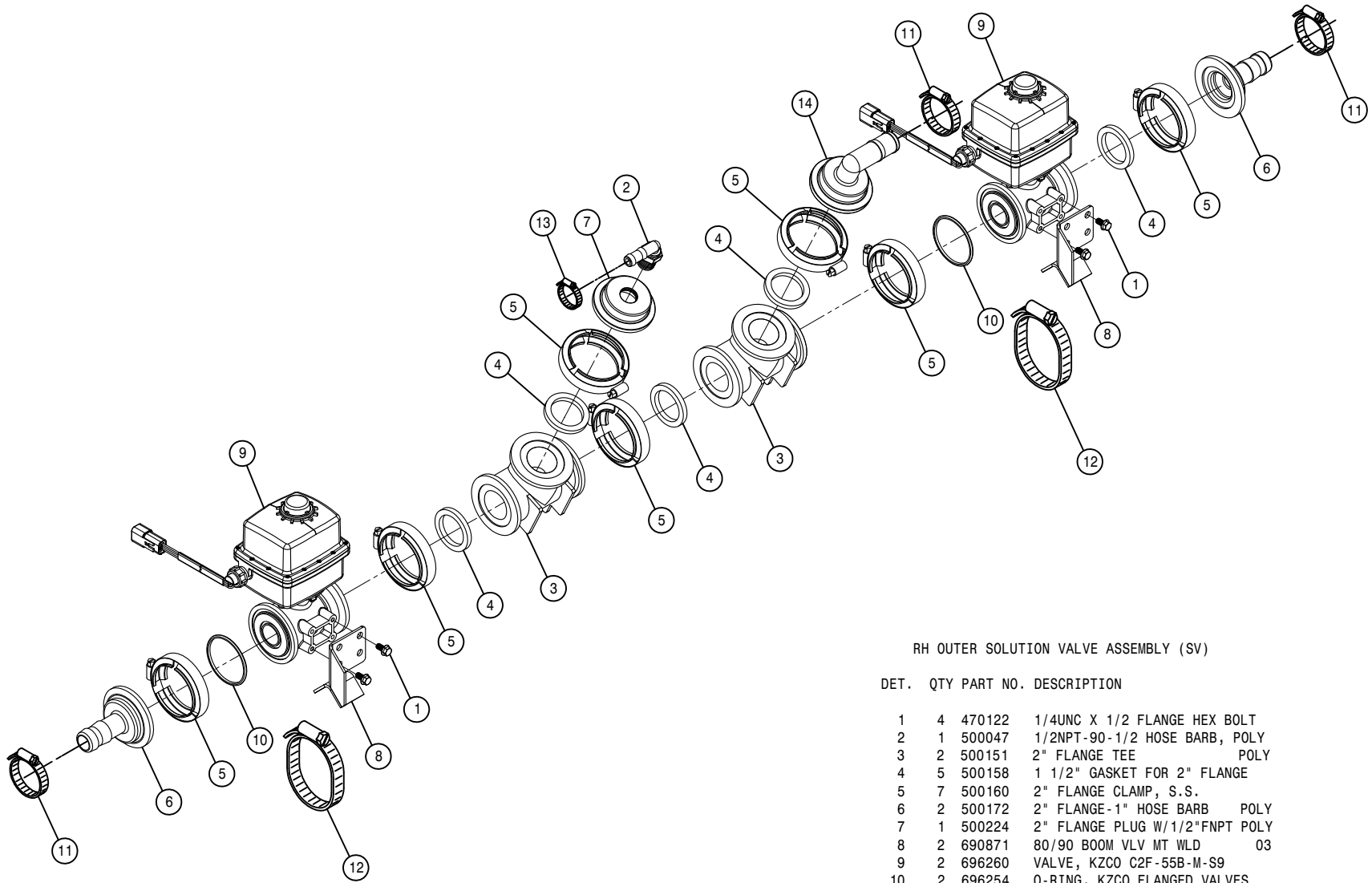

RH OUTER SOLUTION VALVE ASSEMBLY (SV)

DET. QTY PART NO. DESCRIPTION

DET.	QTY	PART NO.	DESCRIPTION
1	4	470122	1/4UNC X 1/2 FLANGE HEX BOLT
2	1	500047	1/2NPT-90-1/2 HOSE BARB, POLY
3	2	500151	2" FLANGE TEE POLY
4	5	500158	1 1/2" GASKET FOR 2" FLANGE
5	7	500160	2" FLANGE CLAMP, S.S.
6	2	500172	2" FLANGE-1" HOSE BARB POLY
7	1	500224	2" FLANGE PLUG W/1/2" FNPT POLY
8	2	690871	80/90 BOOM VLV MT WLD 03
9	2	696260	VALVE, KZCO C2F-55B-M-S9
10	2	696254	O-RING, KZCO FLANGED VALVES
11	3	520090	HOSE CLAMP NO 16 STAINLESS
12	2	520085	HOSE CLAMP NO 24 STAINLESS
13	1	520070	HOSE CLAMP NO 8 STAINLESS
14	1	500189	2" FLANGE-90-1" HOSE BARB POLY

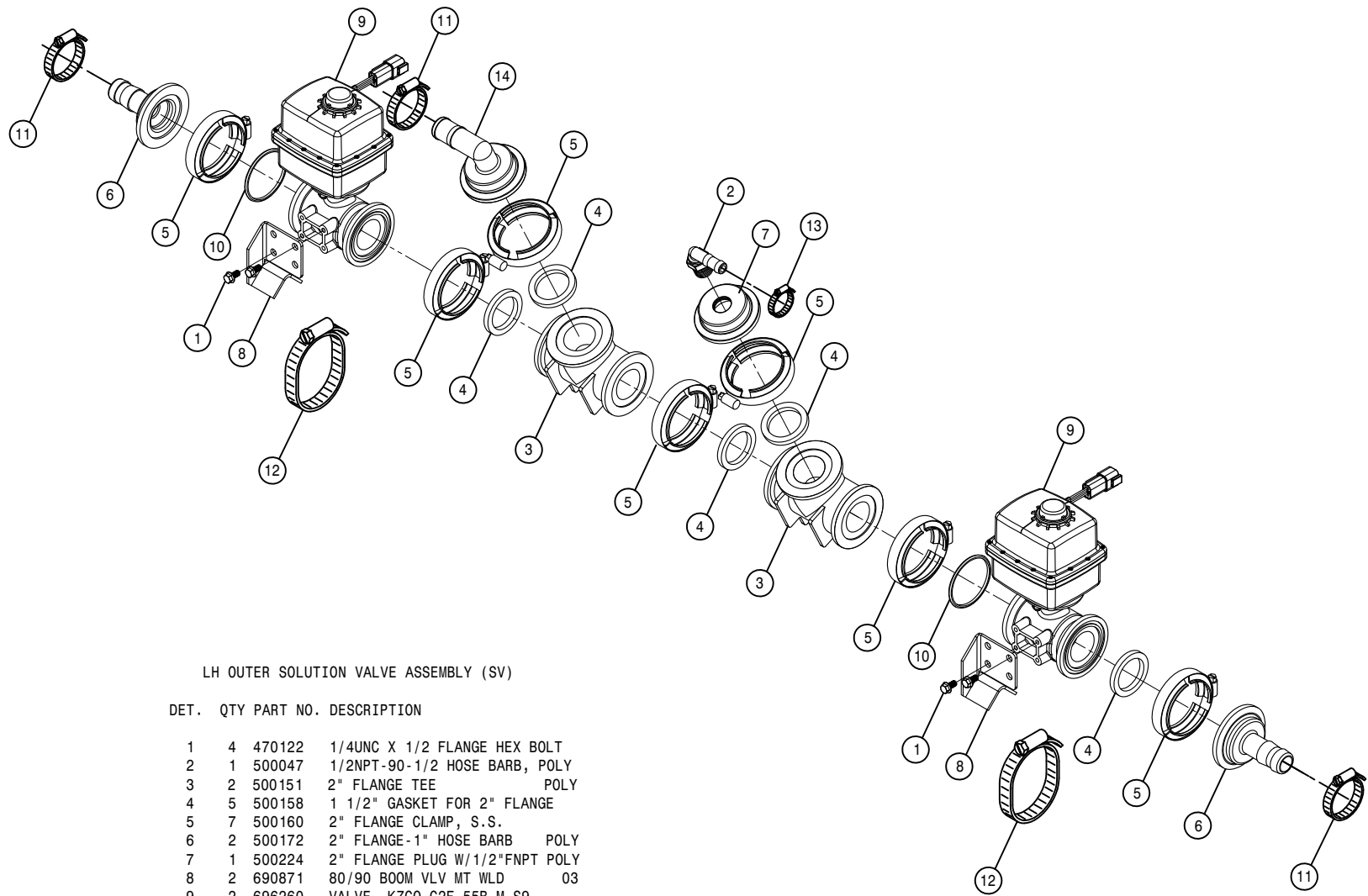

LH OUTER SOLUTION VALVE ASSEMBLY (SV)

DET. QTY PART NO. DESCRIPTION

DET.	QTY	PART NO.	DESCRIPTION
1	4	470122	1/4UNC X 1/2 FLANGE HEX BOLT
2	1	500047	1/2NPT-90-1/2 HOSE BARB, POLY
3	2	500151	2" FLANGE TEE POLY
4	5	500158	1 1/2" GASKET FOR 2" FLANGE
5	7	500160	2" FLANGE CLAMP, S.S.
6	2	500172	2" FLANGE-1" HOSE BARB POLY
7	1	500224	2" FLANGE PLUG W/1/2"FNPT POLY
8	2	690871	80/90 BOOM VLV MT WLD 03
9	2	696260	VALVE, KZCO C2F-55B-M-S9
10	2	696254	O-RING, KZCO FLANGED VALVES
11	3	520090	HOSE CLAMP NO 16 STAINLESS
12	2	520085	HOSE CLAMP NO 24 STAINLESS
13	1	520070	HOSE CLAMP NO 8 STAINLESS
14	1	500189	2" FLANGE-90-1" HOSE BARB POLY

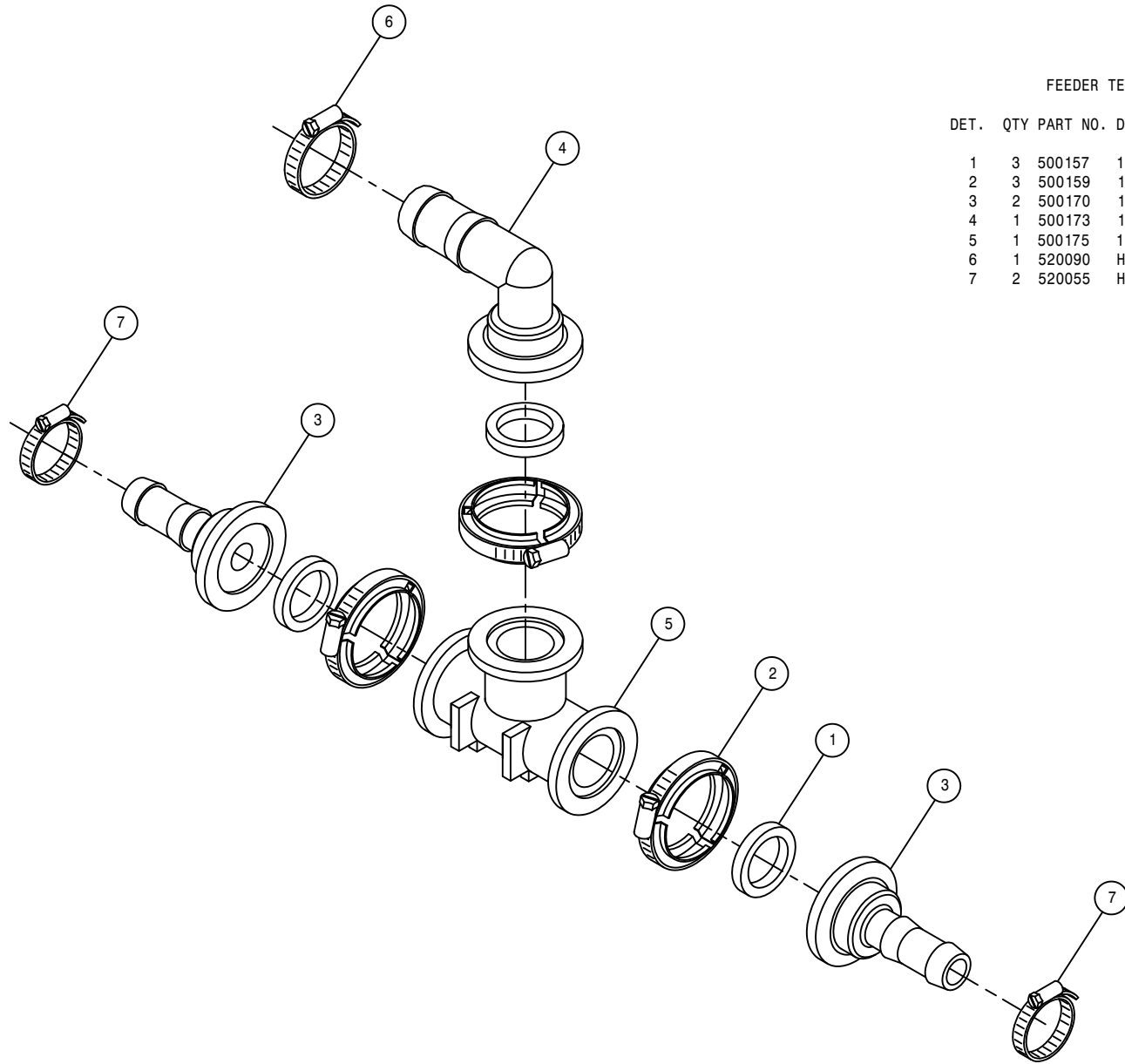

FEEDER TEE ASSEMBLY (SV)

DET.	QTY	PART NO.	DESCRIPTION	
1	3	500157	1" FLANGE GASKET	EPDM
2	3	500159	1" FLANGE CLAMP, S.S.	
3	2	500170	1" FLANGE-3/4" HOSE BARB	POLY
4	1	500173	1" FLANGE-90-1" HOSE BARB	POLY
5	1	500175	1" FLANGE TEE	POLY
6	1	520090	HOSE CLAMP NO 16	STAINLESS
7	2	520055	HOSE CLAMP NO 12	STAINLESS

80' -90' FEEDER TEE ASSEMBLY (SV)

DET. QTY PART NO. DESCRIPTION

1	5	500157	1" FLANGE GASKET	EPDM
2	5	500159	1" FLANGE CLAMP, S.S.	
3	1	500171	1" FLANGE-1" HOSE BARB	POLY
4	3	500170	1" FLANGE-3/4" HOSE BARB	POLY
5	2	500175	1" FLANGE TEE	POLY
6	3	520055	HOSE CLAMP NO 12	STAINLESS
7	1	520090	HOSE CLAMP NO 16	STAINLESS

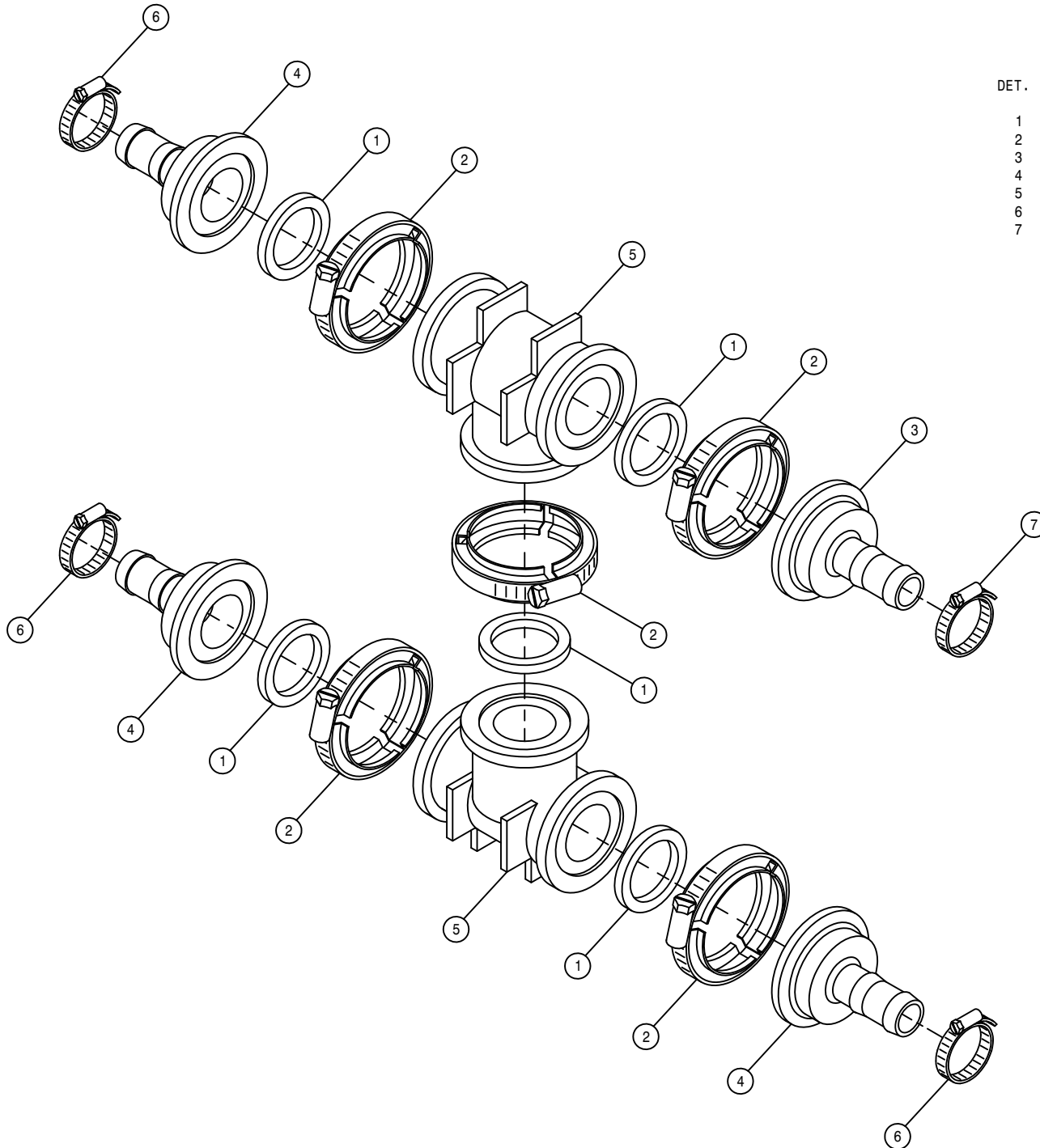

90° BALL VALVE ASSEMBLY (SV)

DET.	QTY	PART NO.	DESCRIPTION
1	4	500157	1" FLANGE GASKET EPDM
2	4	500159	1" FLANGE CLAMP, S.S.
3	2	500170	1" FLANGE-3/4" HOSE BARB POLY
4	2	701191	1" SOLU VLV MT WLD
5	2	696147	BALL VLV, 1" FLANGE
6	2	520087	HOSE CLAMP NO 20 STAINLESS
7	4	520055	HOSE CLAMP NO 12 STAINLESS
8	2	500185	1" FLANGE-90-3/4" HOSE BARB POLY

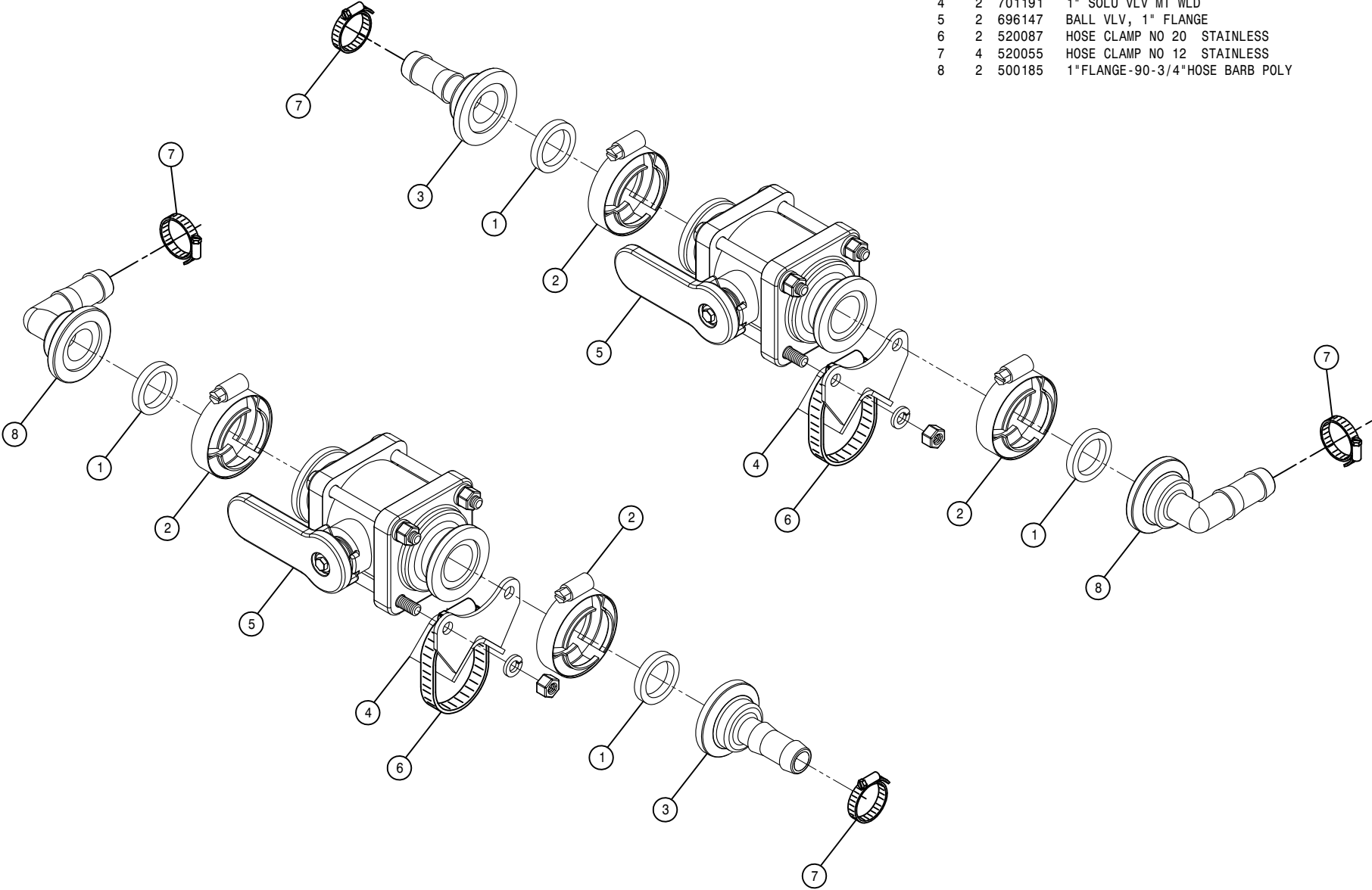

FRONT FILL SOLUTION TANK HOISING (HV)

DET. QTY PART NO. DESCRIPTION

DET.	QTY	PART NO.	DESCRIPTION
1	1	601705	HOSE, 1 X 170 1BR BLK EPDM
2	1	601674	HOSE, 1/4 X 120 1 BR BLK EPDM
3	1	601743	HOSE, 2 X 113 2F-1W EPDM
4	1	601613	HOSE, 2 X 43 2F-1W EPDM
5	1	601502	HOSE, 2 X 56 2F-1W EPDM
6	1	601643	HOSE, 1/2 X 286 1BR BLK EPDM
7	1	601634	HOSE, 1/2 X 78 1BR BLK EPDM
8	1	601677	HOSE, 1/2 X 100 1BR BLK EPDM
9	1	601663	HOSE, 3 X 50 POLY HELIX EPDM
10	1	601706	HOSE, 1 1/2 X 60 2BR BLK EPDM
11	1	601590	HOSE, 1 X 6 1BR BLK EPDM
12	1	601628	HOSE, 2 X 51 2F-1W EPDM
13	2	601566	HOSE, 1/2 X 252 1BR BLK EPDM
14	1	601397	HOSE, 1 1/2 X 120 2BR BLK EPDM
15	1	601522	HOSE, 1 X 204 1BR BLK EPDM
16	1	601273	HOSE, 1 X 132 1BR BLK EPDM
17	1	601508	HOSE, 3 X 64 POLY HELIX EPDM
18	2	601240	HOSE, 1 1/2 X 84 2F-1W EPDM
19	1	601521	HOSE, 1 X 72 1BR BLK EPDM
20	2	601725	HOSE, 1 X 225 1BR BLK EPDM
21	1	601518	HOSE, 1 1/2 X 300 2BR BLK EPDM
22	1	601519	HOSE, 1 1/2 X 396 2BR BLK EPDM
23	1	601682	HOSE, 1 X 111 2BR BLK EPDM
24	1	601680	HOSE, 3 X 91 POLY HELIX EPDM
25	1	601529	HOSE, 3/4 X 34 CLEAR VINYL
26	1	601728	HOSE, 3/4 X 60 CLEAR VINYL
27	1	601742	HOSE, 1" X 16 CLEAR VINYL
28	2	601556	HOSE, 1 X 48 1BR BLK EPDM
29	2	601510	HOSE, 1 X 26 1BR BLK EPDM

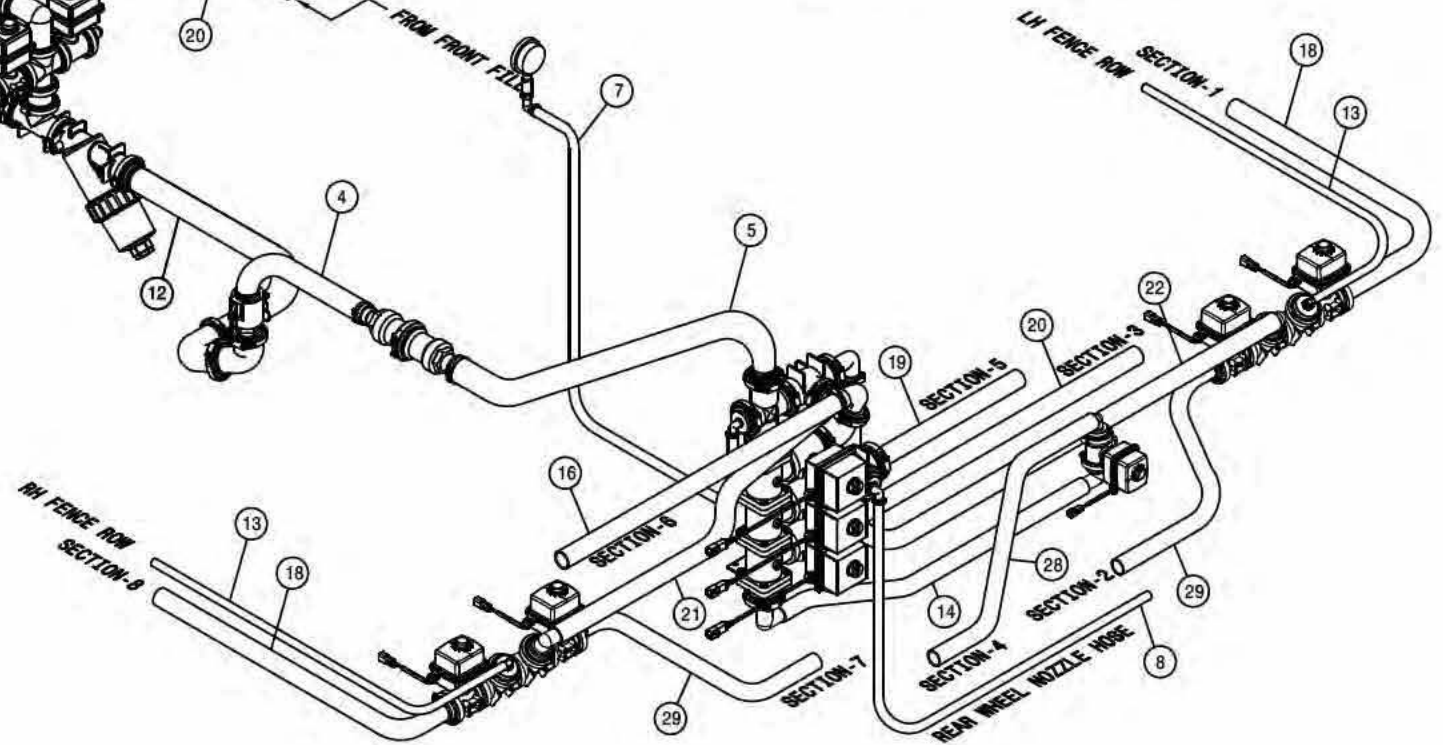
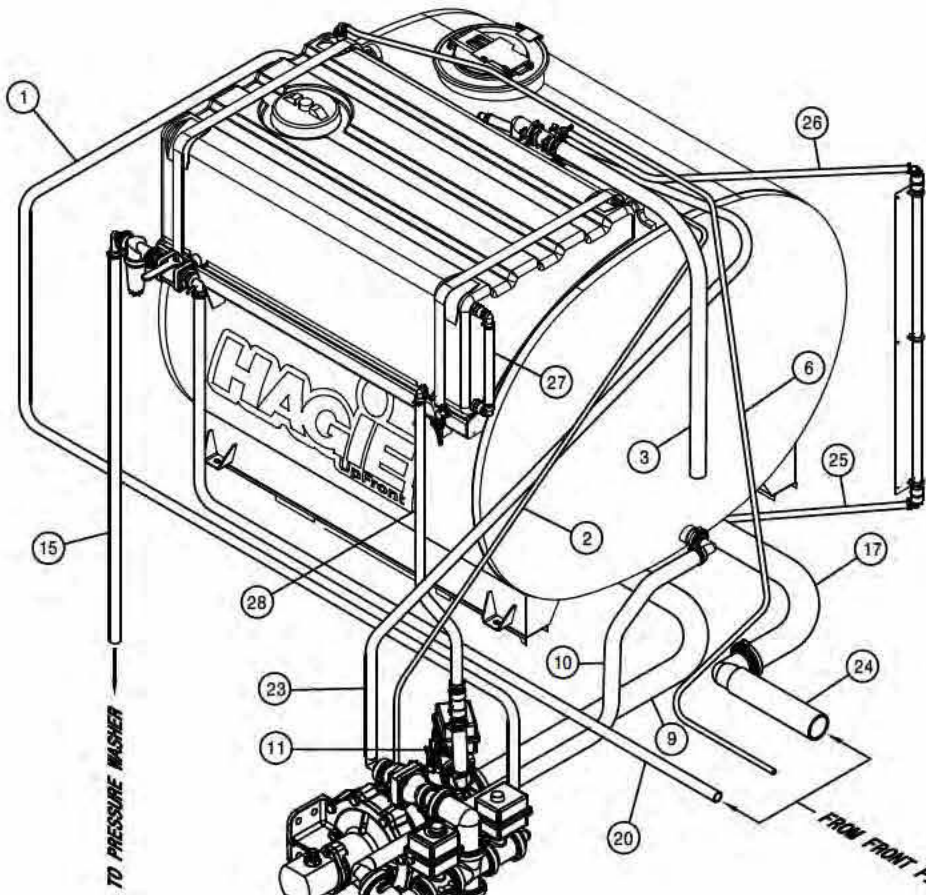

SIDE FILL SOLUTION HOISING (HV)

DET. QTY PART NO. DESCRIPTION

DET.	QTY	PART NO.	DESCRIPTION
1	1	601705	HOSE, 1 X 170 1BR BLK EPDM
2	1	601674	HOSE, 1/4 X 120 1 BR BLK EPDM
3	1	601743	HOSE, 2 X 113 2F-1W EPDM
4	1	601613	HOSE, 2 X 43 2F-1W EPDM
5	1	601502	HOSE, 2 X 56 2F-1W EPDM
6	1	601643	HOSE, 1/2 X 286 1BR BLK EPDM
7	1	601634	HOSE, 1/2 X 78 1BR BLK EPDM
8	1	601677	HOSE, 1/2 X 100 1BR BLK EPDM
9	1	601663	HOSE, 3 X 50 POLY HELIX EPDM
10	1	601706	HOSE, 1 1/2 X 60 2BR BLK EPDM
11	1	601590	HOSE, 1 X 6 1BR BLK EPDM
12	1	601628	HOSE, 2 X 51 2F-1W EPDM
13	2	601566	HOSE, 1/2 X 252 1BR BLK EPDM
14	1	601273	HOSE, 1 X 132 1BR BLK EPDM
15	1	601522	HOSE, 1 X 204 1BR BLK EPDM
16	1	601645	HOSE, 3 X 94 POLY HELIX EPDM
17	1	601574	HOSE, 3 X 36 POLY HELIX EPDM
18	1	690731	SOLU TUBE, 3.00 S.S. SIDE FILL
19	1	601391	HOSE, 1 X 274 1BR BLK EPDM
20	2	601240	HOSE, 1 1/2 X 84 2F-1W EPDM
21	1	601521	HOSE, 1 X 72 1BR BLK EPDM
22	1	601725	HOSE, 1 X 225 1BR BLK EPDM
23	1	601518	HOSE, 1 1/2 X 300 2BR BLK EPDM
24	1	601519	HOSE, 1 1/2 X 396 2BR BLK EPDM
25	1	601682	HOSE, 1 X 111 2BR BLK EPDM
26	1	601529	HOSE, 3/4 X 34 CLEAR VINYL
27	1	601728	HOSE, 3/4 X 60 CLEAR VINYL
28	1	601742	HOSE, 1" X 16 CLEAR VINYL
29	2	601556	HOSE, 1 X 48 1BR BLK EPDM
30	1	601510	HOSE, 1 X 26 1BR BLK EPDM
31	1	601397	HOSE, 1 1/2 X 120 2BR BLK EPDM

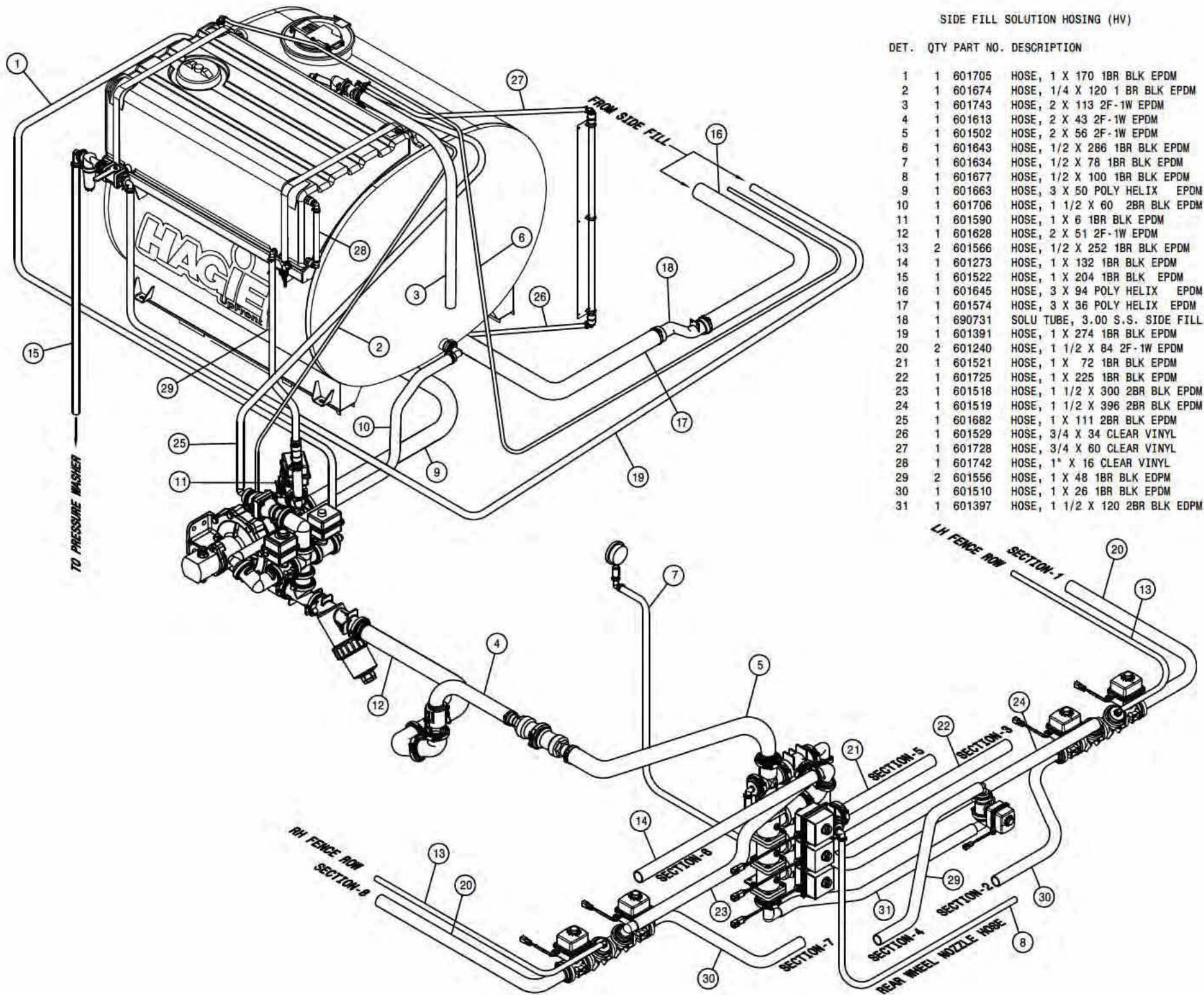

DET. QTY PART NO. DESCRIPTION

1	2	500074	1"NPT-1" HOSE BARB, POLY
2	1	500104	1/4NPT-90-1/4 HOSE BARB, POLY
3	2	500157	1" FLANGE GASKET EPDM
4	8	500158	1 1/2" GASKET FOR 2" FLANGE
5	2	500159	1" FLANGE CLAMP, S.S.
6	11	500160	2" FLANGE CLAMP, S.S.
7	1	500161	2"FLANGE-1"FLANGE COUPLER,POLY
8	1	500173	1" FLANGE-90-1" HOSE BARB POLY
9	1	500176	2" FLANGE CROSS POLY
10	3	500180	2"FLANGE-90-2"FLANGE LBO POLY
11	2	500189	2" FLANGE-90-1" HOSE BARB POLY
12	4	500194	2"FP FLANGE CLAMP, S.S.
13	4	500195	2"FP FLANGE GASKET EPDM
14	1	500196	2"FP FLANGE-2" HOSE BARB POLY
15	1	500199	2"FP FLANGE-2"FLANGE REDU POLY
16	1	500205	2"FP FLANGE-2"MNPT ADPTR S.S.
17	1	500207	2"FP FLANGE TEE POLY
18	3	500208	3" FLANGE CLAMP, S.S.
19	3	500209	3" FLANGE GASKET EPDM
20	1	500210	3" FLANGE-3" HOSE BARB POLY
21	1	500217	3" FLANGE TEE POLY
22	1	500234	3"FP FLANGE-3"MNPT ADPTR S.S.
23	1	500237	3"FLANGE-2"FLANGE REDU POLY
24	5	520090	HOSE CLAMP NO 16 STAINLESS
25	1	601590	HOSE, 1 X 6 1BR BLK EPDM
26	1	650125	DECAL,AGIT RATE IND, KZCO VLV
27	1	690488	1.00 CHECK VLV, SPRING LOADED
28	1	691036	HYPRO 9307 PUMP
29	1	696006	LINE "Y" STRAINER,2"FP FLG 50M
30	1	696008	PRESS RELIEF VLV,100PSI,1"FLG
31	3	696254	O-RING, KZCO FLANGED VALVES
32	2	696256	VALVE, KZCO C2F-60B-M-S9
33	1	696257	VALVE, KZCO C2F-62-Q-S9
34	1	611128	7/8MJIC-90-7/8MOR LBO
35	1	611127	1 1/16MJIC-1 1/16MOR ADPTR
36	1	500153	2" FLANGE-90-1 1/2 HBARB POLY
37	4	900334	5/8UNC X 1 3/4 HEX BOLT
38	4	914010	5/8UNC HEX STOVER NUT
39	1	520120	HOSE CLAMP NO 4 STAINLESS
40	1	520141	2.31/2.62 T-BOLT HOSE CLAMP SS
41	1	520145	3.56/3.88 T-BOLT HOSE CLAMP SS
42	1	520067	HOSE CLAMP NO 28 STAINLESS
43	1	691068	MECHANICAL SEAL KIT FOR 691036
44	1	691069	BEARING KIT FOR 691036
45	1	691070	IMPELLER HDWE KIT FOR 691036
46	1	691071	HYD MOTOR SEAL FOR 691036
47	1	691072	HYD MOTOR (GM10) FOR 691036
48	1	691073	SHAFT ASSEMBLY FOR 691036
49	1	691074	SEAL FLANGE FOR 691036
50	1	691075	IMPELLER FOR 691036
51	1	691076	O-RING,FLANGE FOR 691036
52	1	696007	50 MESH SCREEN FOR 696006
53	1	696009	80 MESH SCREEN FOR 696006
54	1	292500	PWM AMPLIFIER,12V
55	2	472235	10-32 X 3/4 PHIL PAN MACH SCR
56	2	470175	10-32 HEX FLANGE LOCK NUT

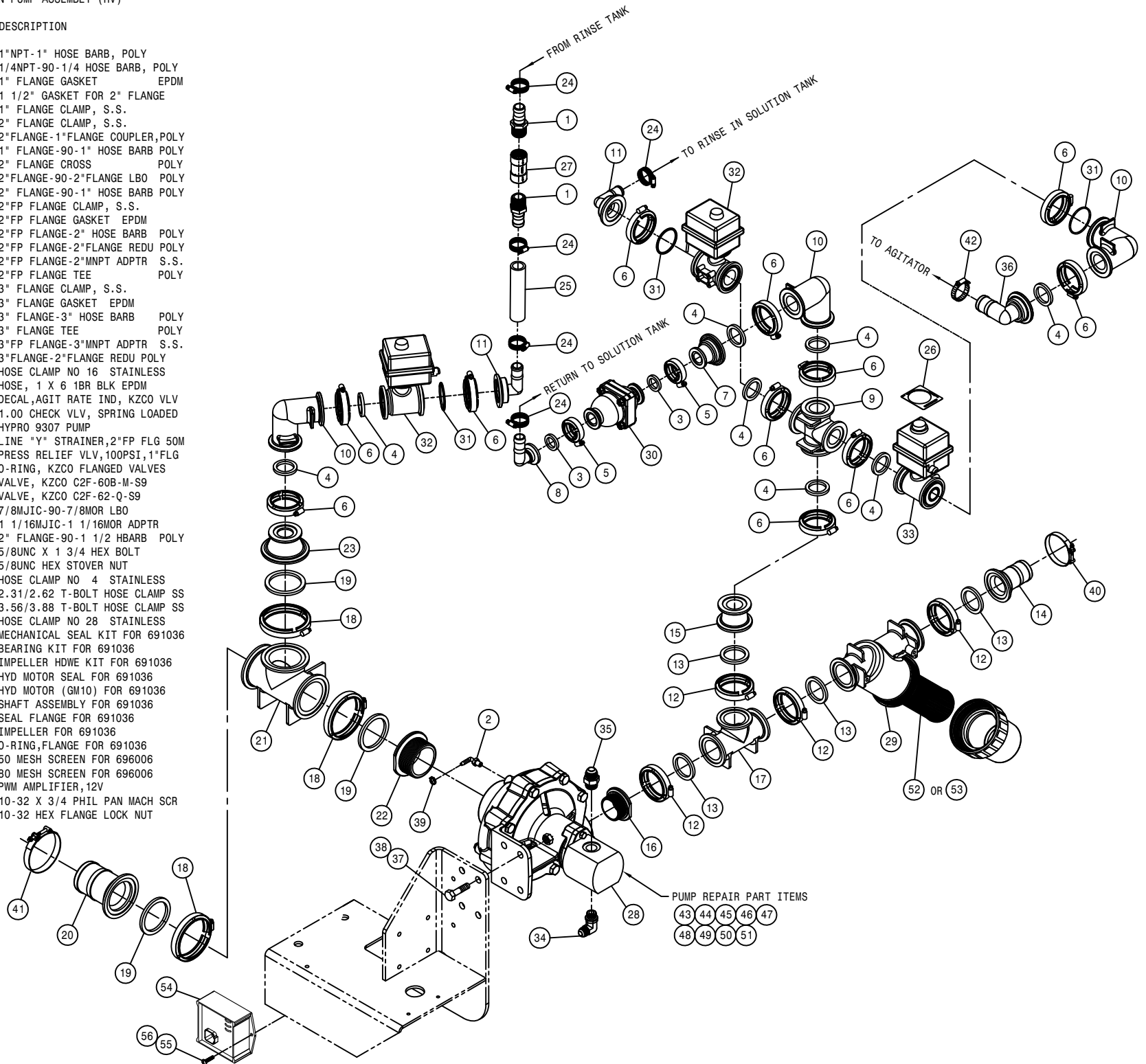

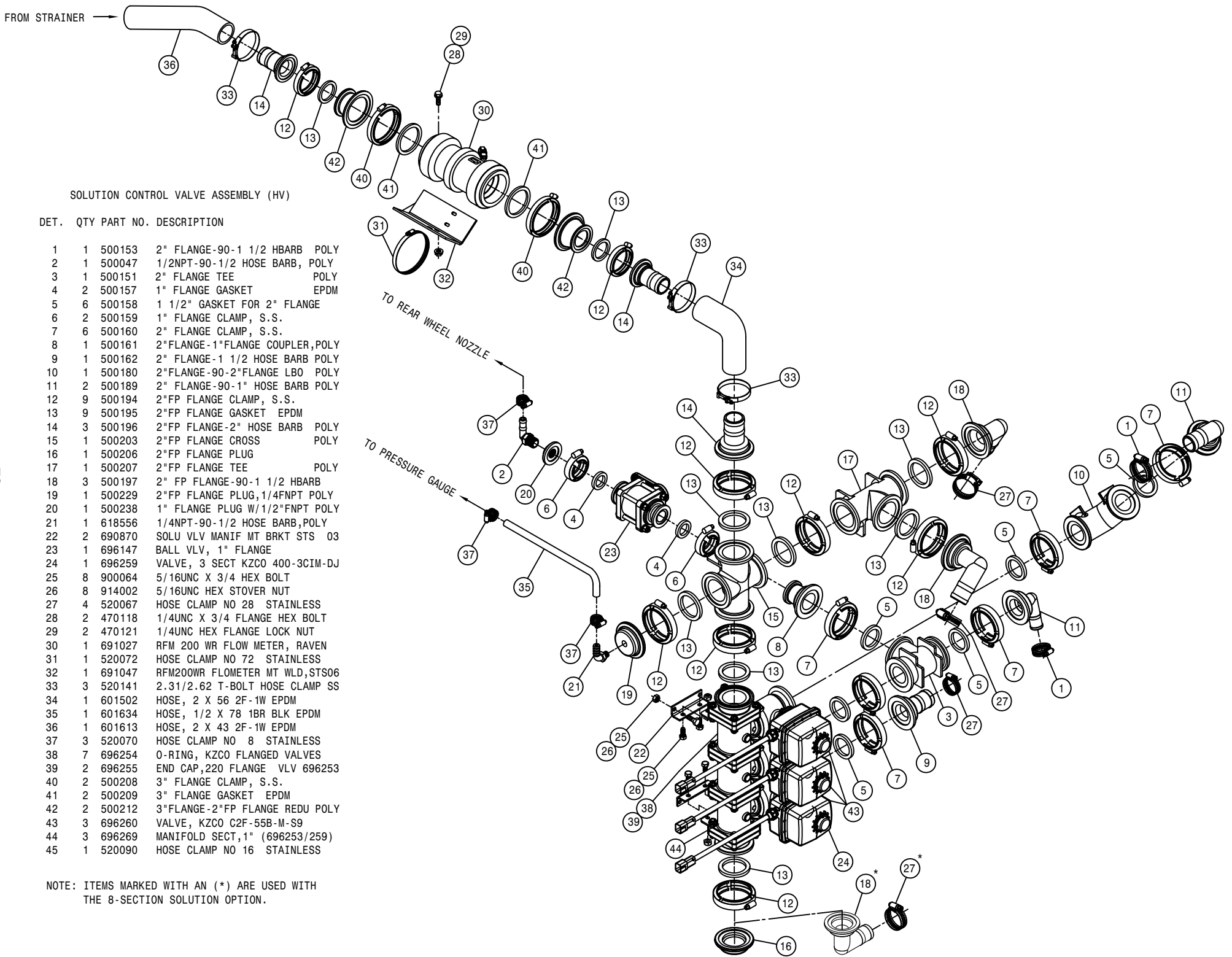

SOLUTION CONTROL VALVE ASSEMBLY (HV)

DET.	QTY	PART NO.	DESCRIPTION
1	1	500153	2" FLANGE-90-1 1/2 HBARB POLY
2	1	500047	1/2NPT-90-1/2 HOSE BARB, POLY
3	1	500151	2" FLANGE TEE POLY
4	2	500157	1" FLANGE GASKET EPDM
5	6	500158	1 1/2" GASKET FOR 2" FLANGE
6	2	500159	1" FLANGE CLAMP, S.S.
7	6	500160	2" FLANGE CLAMP, S.S.
8	1	500161	2"FLANGE-1"FLANGE COUPLER,POLY
9	1	500162	2" FLANGE-1 1/2 HOSE BARB POLY
10	1	500180	2"FLANGE-90-2"FLANGE LBO POLY
11	2	500189	2" FLANGE-90-1" HOSE BARB POLY
12	9	500194	2"FP FLANGE CLAMP, S.S.
13	9	500195	2"FP FLANGE GASKET EPDM
14	3	500196	2"FP FLANGE-2" HOSE BARB POLY
15	1	500203	2"FP FLANGE CROSS POLY
16	1	500206	2"FP FLANGE PLUG
17	1	500207	2"FP FLANGE TEE POLY
18	3	500197	2" FP FLANGE-90-1 1/2 HBARB
19	1	500229	2"FP FLANGE PLUG,1/4FNPT POLY
20	1	500238	1" FLANGE PLUG W/1/2"FNPT POLY
21	1	618556	1/4NPT-90-1/2 HOSE BARB,POLY
22	2	690870	SOLU VLV MANIF MT BRKT STS 03
23	1	696147	BALL VLV, 1" FLANGE
24	1	696259	VALVE, 3 SECT KZCO 400-3CIM-DJ
25	8	900064	5/16UNC X 3/4 HEX BOLT
26	8	914002	5/16UNC HEX STOVER NUT
27	4	520067	HOSE CLAMP NO 28 STAINLESS
28	2	470118	1/4UNC X 3/4 FLANGE HEX BOLT
29	2	470121	1/4UNC HEX FLANGE LOCK NUT
30	1	691027	RFM 200 WR FLOW METER, RAVEN
31	1	520072	HOSE CLAMP NO 72 STAINLESS
32	1	691047	RFM200WR FLOMETER MT WLD,STS06
33	3	520141	2.31/2.62 T-BOLT HOSE CLAMP SS
34	1	601502	HOSE, 2 X 56 2F-1W EPDM
35	1	601634	HOSE, 1/2 X 78 1BR BLK EPDM
36	1	601613	HOSE, 2 X 43 2F-1W EPDM
37	3	520070	HOSE CLAMP NO 8 STAINLESS
38	7	696254	O-RING, KZCO FLANGED VALVES
39	2	696255	END CAP,220 FLANGE VLV 696253
40	2	500208	3" FLANGE CLAMP, S.S.
41	2	500209	3" FLANGE GASKET EPDM
42	2	500212	3"FLANGE-2"FP FLANGE REDU POLY
43	3	696260	VALVE, KZCO C2F-55B-M-S9
44	3	696269	MANIFOLD SECT,1" (696253/259)
45	1	520090	HOSE CLAMP NO 16 STAINLESS

NOTE: ITEMS MARKED WITH AN (*) ARE USED WITH THE 8-SECTION SOLUTION OPTION.

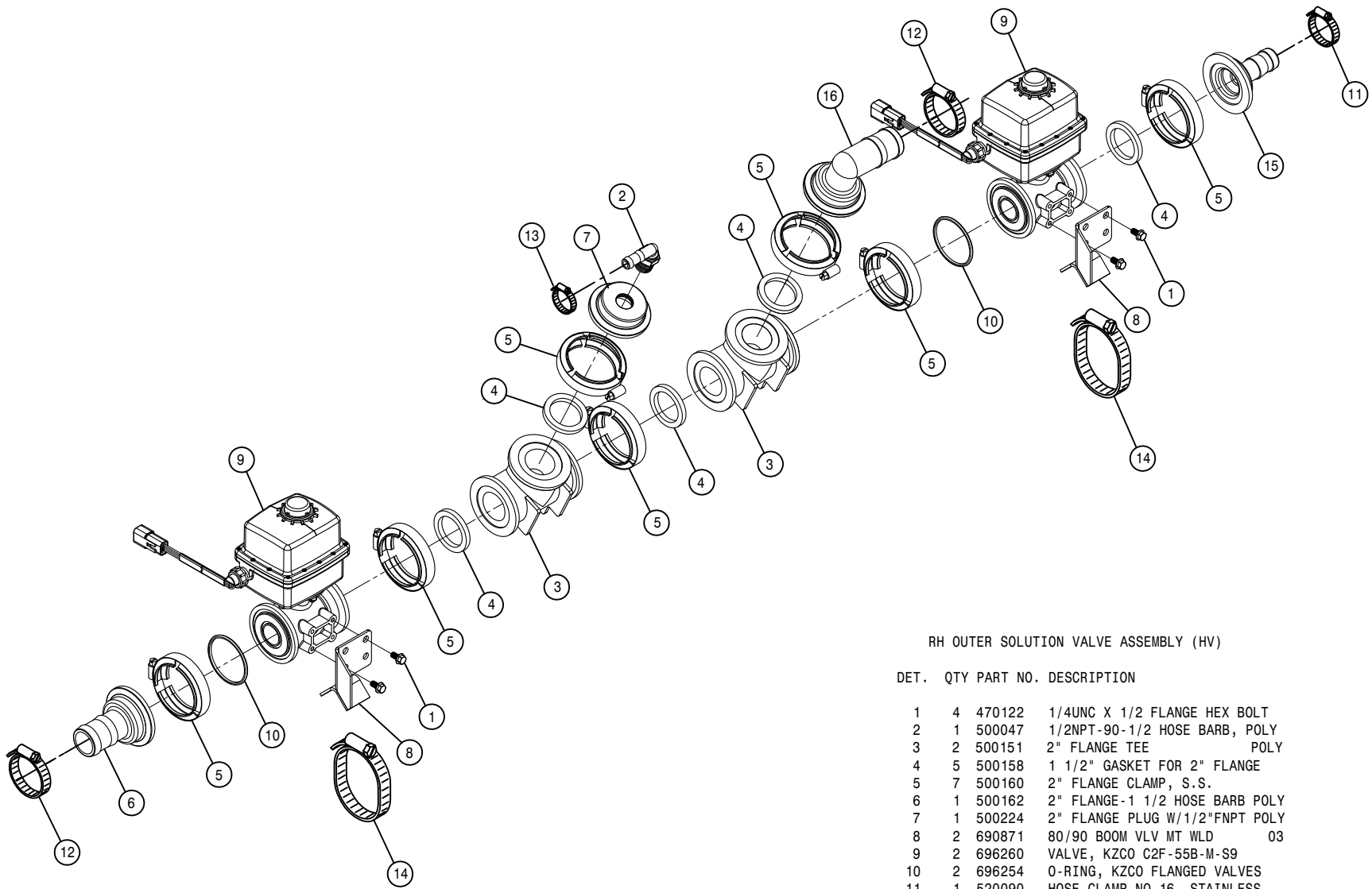

RH OUTER SOLUTION VALVE ASSEMBLY (HV)

DET. QTY PART NO. DESCRIPTION

DET.	QTY	PART NO.	DESCRIPTION
1	4	470122	1/4UNC X 1/2 FLANGE HEX BOLT
2	1	500047	1/2NPT-90-1/2 HOSE BARB, POLY
3	2	500151	2" FLANGE TEE POLY
4	5	500158	1 1/2" GASKET FOR 2" FLANGE
5	7	500160	2" FLANGE CLAMP, S.S.
6	1	500162	2" FLANGE-1 1/2 HOSE BARB POLY
7	1	500224	2" FLANGE PLUG W/1/2"FNPT POLY
8	2	690871	80/90 BOOM VLV MT WLD 03
9	2	696260	VALVE, KZCO C2F-55B-M-S9
10	2	696254	O-RING, KZCO FLANGED VALVES
11	1	520090	HOSE CLAMP NO 16 STAINLESS
12	2	520067	HOSE CLAMP NO 28 STAINLESS
13	1	520070	HOSE CLAMP NO 8 STAINLESS
14	2	520085	HOSE CLAMP NO 24 STAINLESS
15	1	500172	2" FLANGE-1" HOSE BARB POLY
16	1	500153	2" FLANGE-90-1 1/2 HBARB POLY

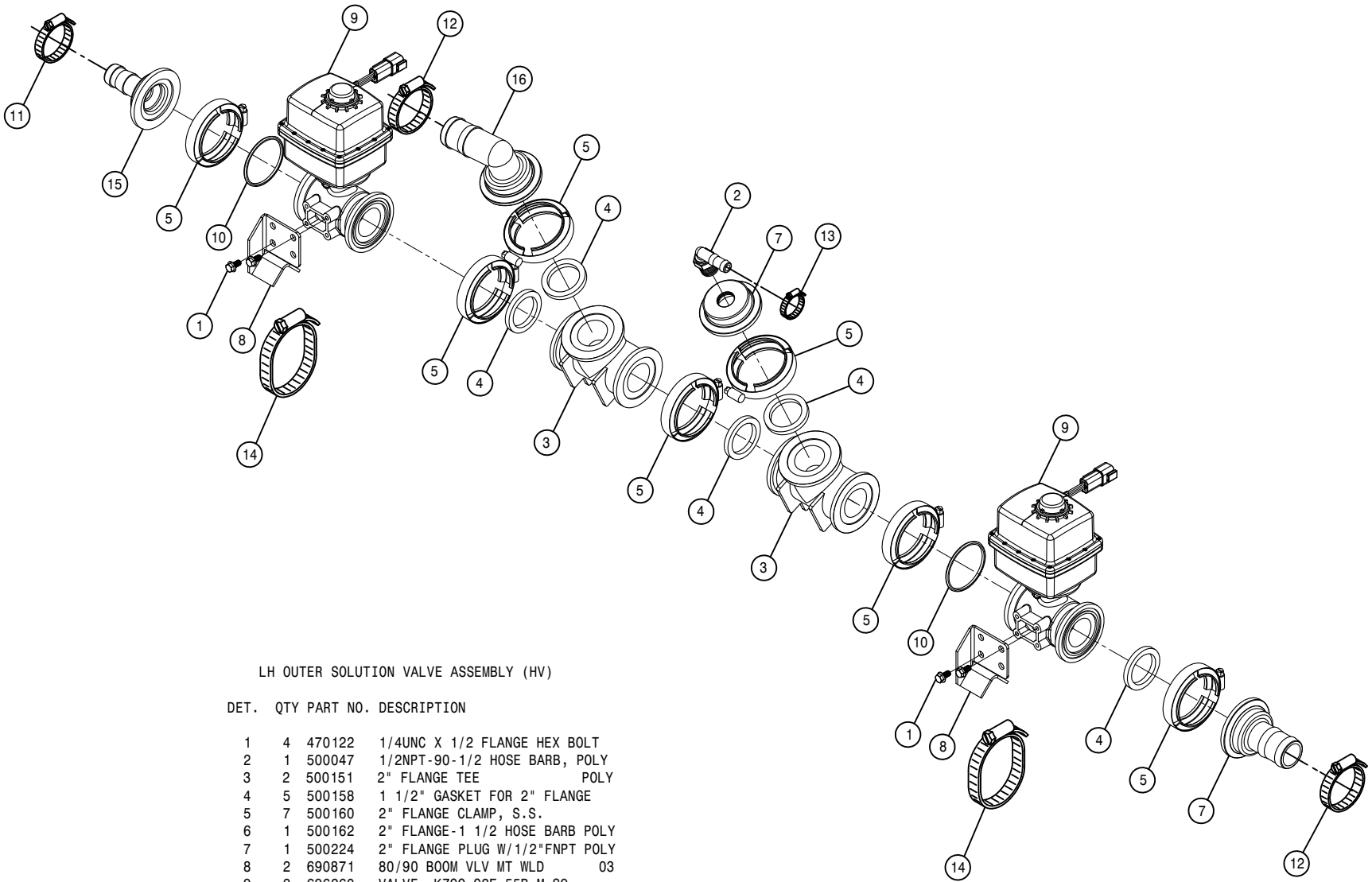

LH OUTER SOLUTION VALVE ASSEMBLY (HV)

DET. QTY PART NO. DESCRIPTION

1	4	470122	1/4UNC X 1/2 FLANGE HEX BOLT
2	1	500047	1/2NPT-90-1/2 HOSE BARB, POLY
3	2	500151	2" FLANGE TEE POLY
4	5	500158	1 1/2" GASKET FOR 2" FLANGE
5	7	500160	2" FLANGE CLAMP, S.S.
6	1	500162	2" FLANGE-1 1/2 HOSE BARB POLY
7	1	500224	2" FLANGE PLUG W/1/2"FNPT POLY
8	2	690871	80/90 BOOM VLV MT WLD 03
9	2	696260	VALVE, KZCO C2F-55B-M-S9
10	2	696254	O-RING, KZCO FLANGED VALVES
11	1	520090	HOSE CLAMP NO 16 STAINLESS
12	2	520067	HOSE CLAMP NO 28 STAINLESS
13	1	520070	HOSE CLAMP NO 8 STAINLESS
14	2	520085	HOSE CLAMP NO 24 STAINLESS
15	1	500172	2" FLANGE-1" HOSE BARB POLY
16	1	500153	2" FLANGE-90-1 1/2 HBARB POLY

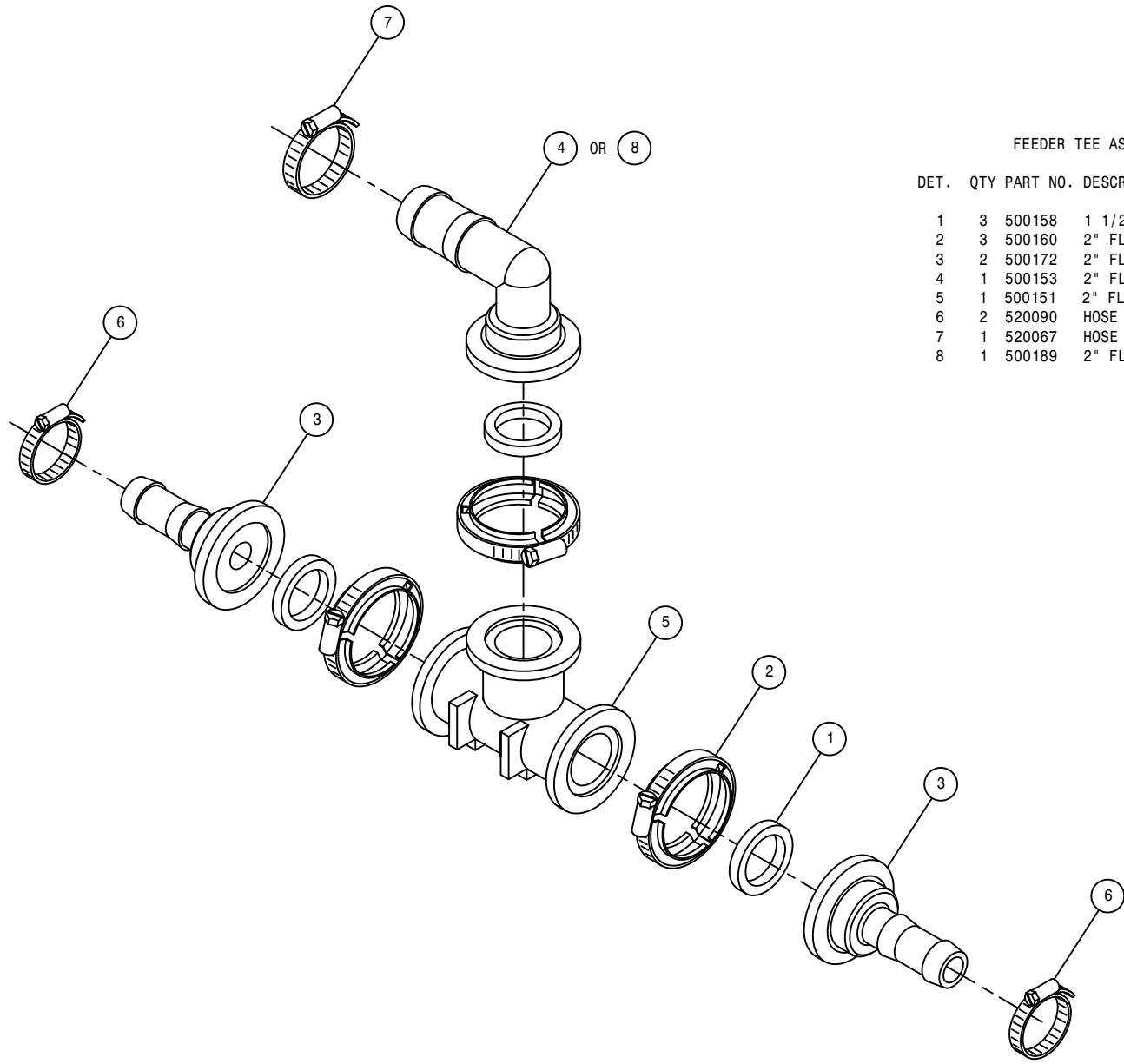

FEEDER TEE ASSEMBLY (HV)

DET.	QTY	PART NO.	DESCRIPTION
1	3	500158	1 1/2" GASKET FOR 2" FLANGE
2	3	500160	2" FLANGE CLAMP, S.S.
3	2	500172	2" FLANGE-1" HOSE BARB POLY
4	1	500153	2" FLANGE-90-1 1/2 HBARB POLY
5	1	500151	2" FLANGE TEE POLY
6	2	520090	HOSE CLAMP NO 16 STAINLESS
7	1	520067	HOSE CLAMP NO 28 STAINLESS
8	1	500189	2" FLANGE-90-1" HOSE BARB POLY

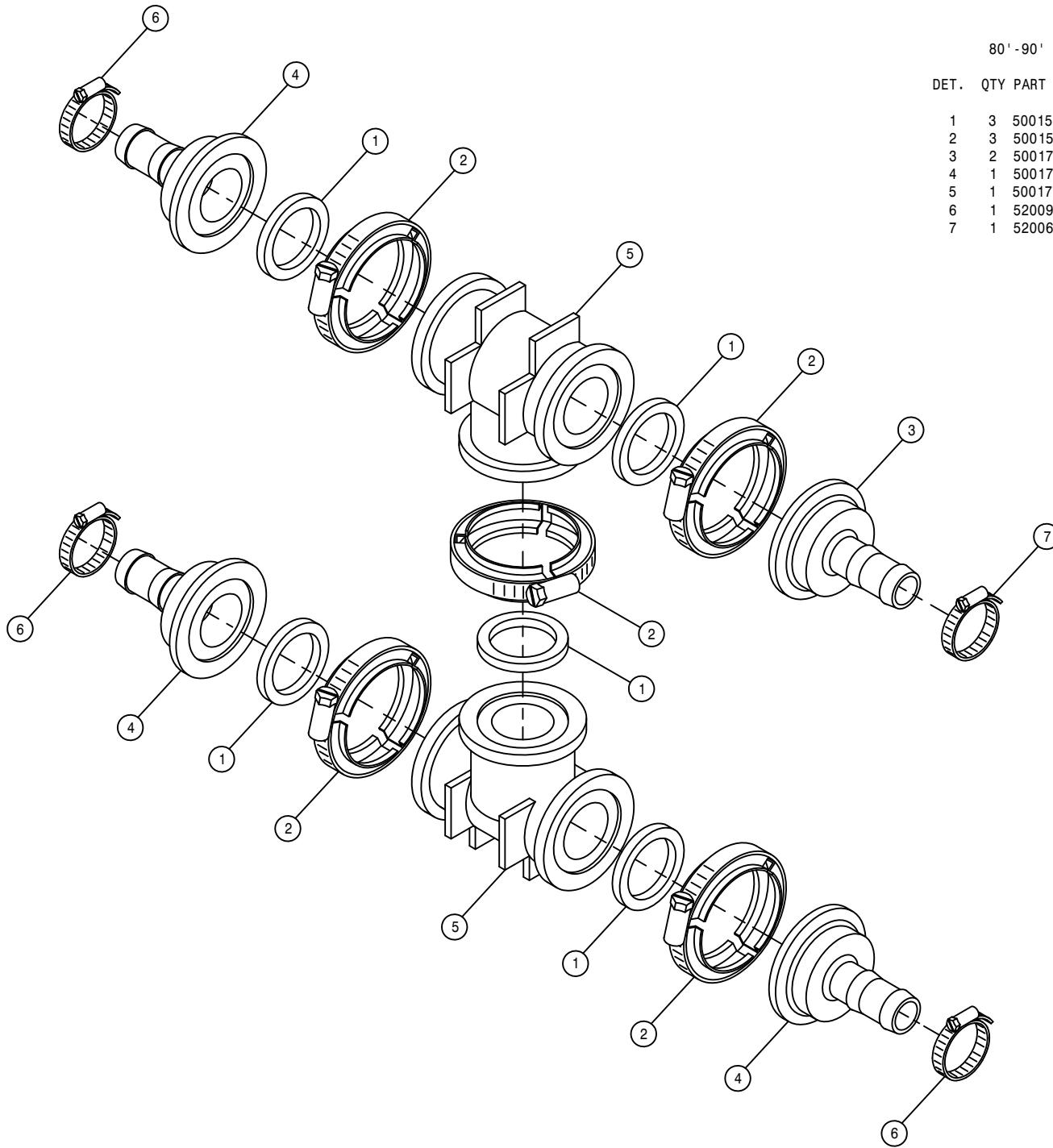

80'-90' FEEDER TEE ASSEMBLY (HV)

DET. QTY PART NO. DESCRIPTION

1	3	500157	1" FLANGE GASKET	EPDM
2	3	500159	1" FLANGE CLAMP, S.S.	
3	2	500170	1" FLANGE-3/4" HOSE BARB	POLY
4	1	500173	1" FLANGE-90-1" HOSE BARB	POLY
5	1	500175	1" FLANGE TEE	POLY
6	1	520090	HOSE CLAMP NO 16	STAINLESS
7	1	520067	HOSE CLAMP NO 28	STAINLESS

90' BALL VALVE ASSEMBLY (HV)

DET. QTY PART NO. DESCRIPTION

1	4	500157	1" FLANGE GASKET	EPDM
2	4	500159	1" FLANGE CLAMP, S.S.	
3	1	500173	1" FLANGE-90-1" HOSE BARB POLY	
4	2	701191	1" SOLU VLV MT WLD	
5	2	696147	BALL VLV, 1" FLANGE	
6	2	520087	HOSE CLAMP NO 20 STAINLESS	
7	1	520090	HOSE CLAMP NO 16 STAINLESS	
8	2	500171	1" FLANGE-1" HOSE BARB POLY	

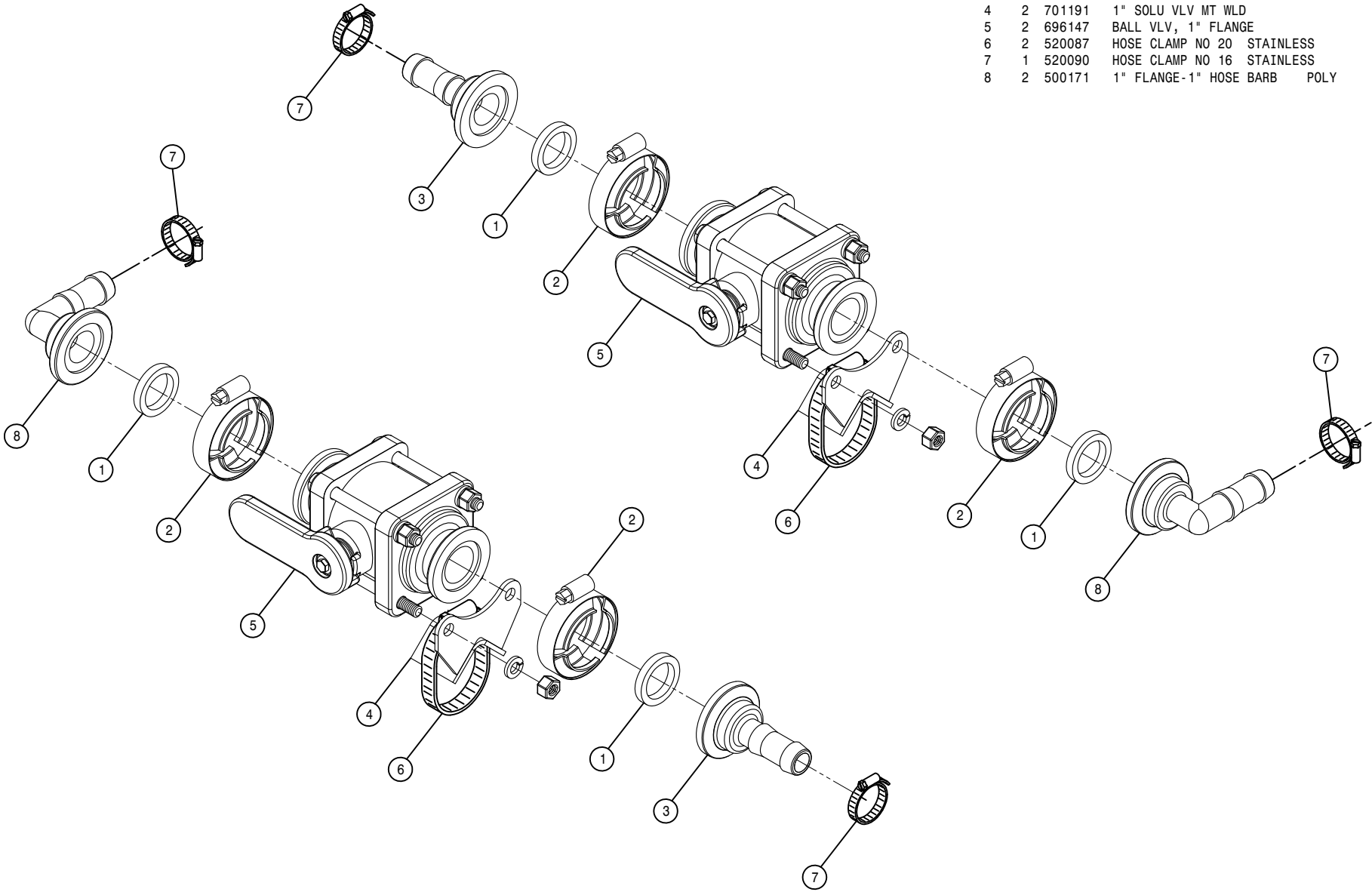

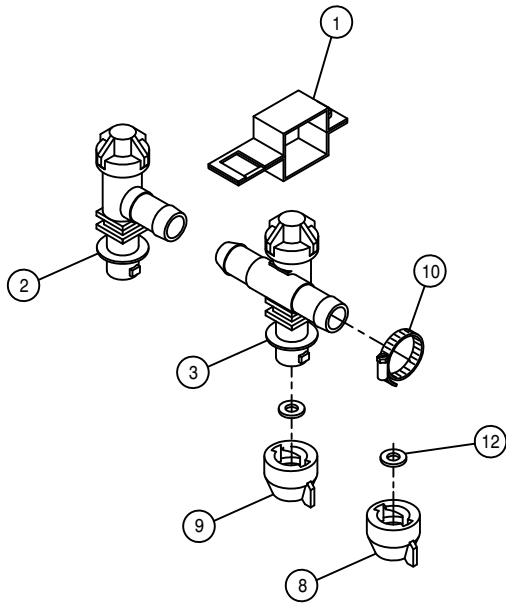

STANDARD SINGLE TIP SPACING

BOOM NOZZLE BODY

DET. QTY PART NO. DESCRIPTION

1	3	737817	NOZL MT CLMP,1.00 SQ SS,Q-TJET
2	1	737829	QUICK TJET LBO,1-TIP BODY .75
3	1	737830	QUICK TJET TEE,1-TIP BODY .75
4	1	737833	LH QUICK TJET LBO,3-TIP .75
5	1	737834	QUICK TJET TEE,3-TIP BODY .75
6	1	737900	LH QUICK TJET LBO,3-TIP 1.00
7	1	737901	QUICK TJET TEE,3-TIP BODY 1.00
8	3	737825	QUICK SHUT-OFF CAP
9	3	737822	CAP SET, YELLOW QUICK TEEJET
10	2	520055	HOSE CLAMP NO 12 STAINLESS
11	1	520090	HOSE CLAMP NO 16 STAINLESS
12	6	737824	QUICK TEEJET SEAT GASKET

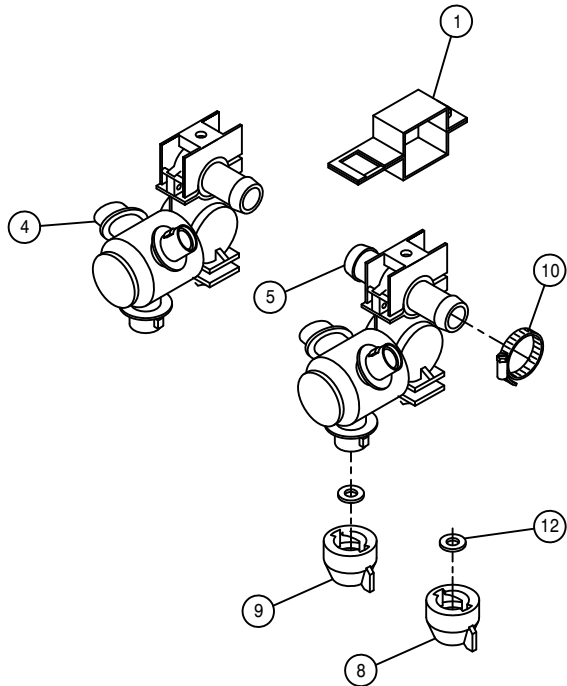

STANDARD TRIPLE TIP SPACING

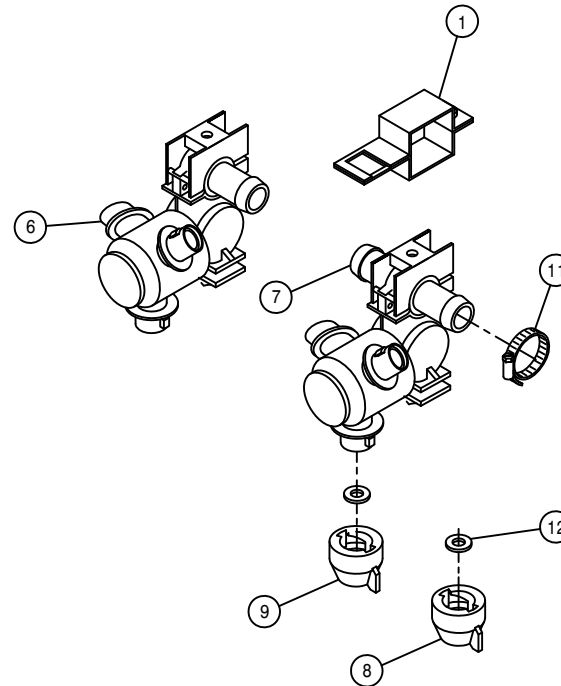

HI-VOLUME TRIPLE TIP SPACING

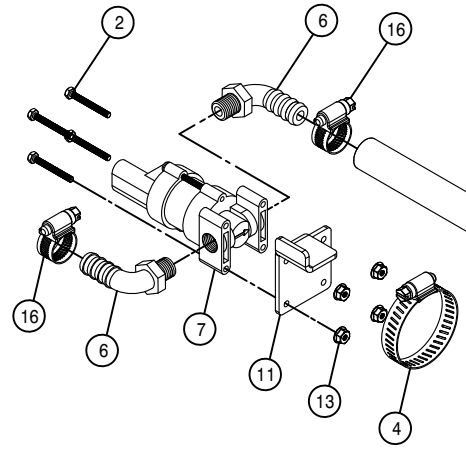

RIGHT FENCE ROW NOZZLE ASSEMBLY

DET. QTY PART NO. DESCRIPTION

1	2	470118	1/4UNC X 3/4 FLANGE HEX BOLT
2	4	473993	6-32 X 1 1/4 HH MACH SCR
3	2	900128	3/8UNC X 3/4 HEX BOLT
4	1	520087	HOSE CLAMP NO 20 STAINLESS
5	1	601720	HOSE, 1/2 X 25 1BR BLK EPDM
6	2	618556	1/4NPT-90-1/2 HOSE BARB,POLY
7	1	696235	1/4" ELECT SOLU SOLE VLV, 2203
8	1	737907	RH FENCE ROW TIP BRKT MT
9	1	737931	11/16-16F-QUICK TJET ADAPTER
10	1	737932	11/16MPS-90-1/2 HBARB NOZLBODY
11	1	737945	MTG BRKT- SOLENOID, FENCE ROW
12	1	737946	MTG BRKT- RH FENCE ROW NOZZLE
13	4	470509	6-32 SERR. FLANGE NUT
14	2	914000	1/4UNC HEX STOVER NUT
15	2	920000	1/4 SAE FLAT WASHER
16	3	520070	HOSE CLAMP NO 8 STAINLESS
17	2	472029	3/8UNC HEX FLANGE NUT SERR SS

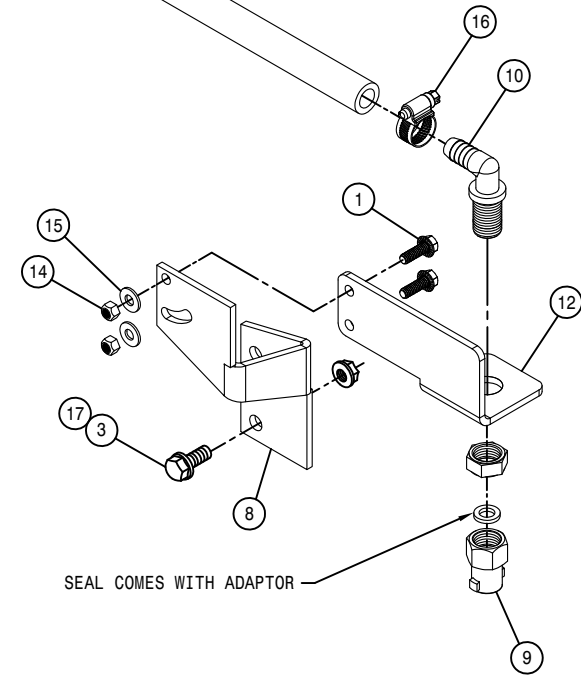

SEAL COMES WITH ADAPTOR

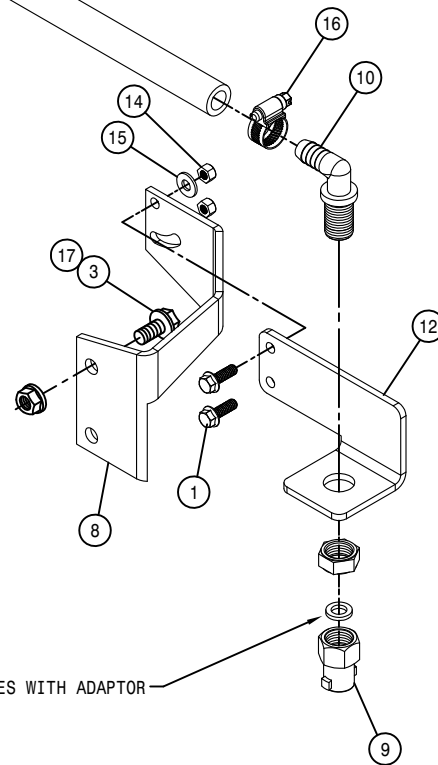
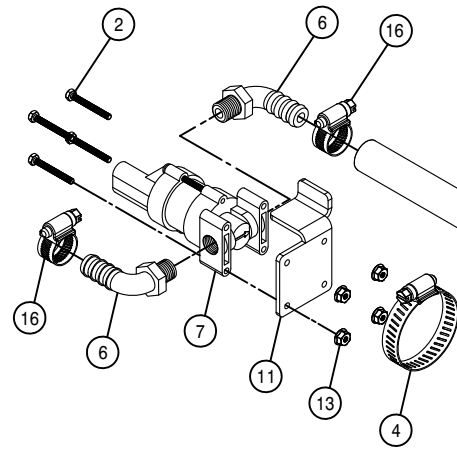

LEFT FENCE ROW NOZZLE ASSEMBLY

DET. QTY PART NO. DESCRIPTION

1	2	470118	1/4UNC X 3/4 FLANGE HEX BOLT
2	4	473993	6-32 X 1 1/4 HH MACH SCR
3	2	900128	3/8UNC X 3/4 HEX BOLT
4	1	520087	HOSE CLAMP NO 20 STAINLESS
5	1	601720	HOSE, 1/2 X 25 1BR BLK EPDM
6	2	618556	1/4NPT-90-1/2 HOSE BARB,POLY
7	1	696235	1/4" ELECT SOLU SOLE VLV, 2203
8	1	737908	LH FENCE ROW TIP BRKT MT
9	1	737931	11/16-16F-QUICK TJET ADAPTER
10	1	737932	11/16MPS-90-1/2 HBARB NOZLBODY
11	1	737945	MTG BRKT- SOLENOID, FENCE ROW
12	1	737947	MTG BRKT- LH FENCE ROW NOZZLE
13	4	470509	6-32 SERR. FLANGE NUT
14	2	914000	1/4UNC HEX STOVER NUT
15	2	920000	1/4 SAE FLAT WASHER
16	3	520070	HOSE CLAMP NO 8 STAINLESS
17	2	472029	3/8UNC HEX FLANGE NUT SERR SS

SEAL COMES WITH ADAPTOR

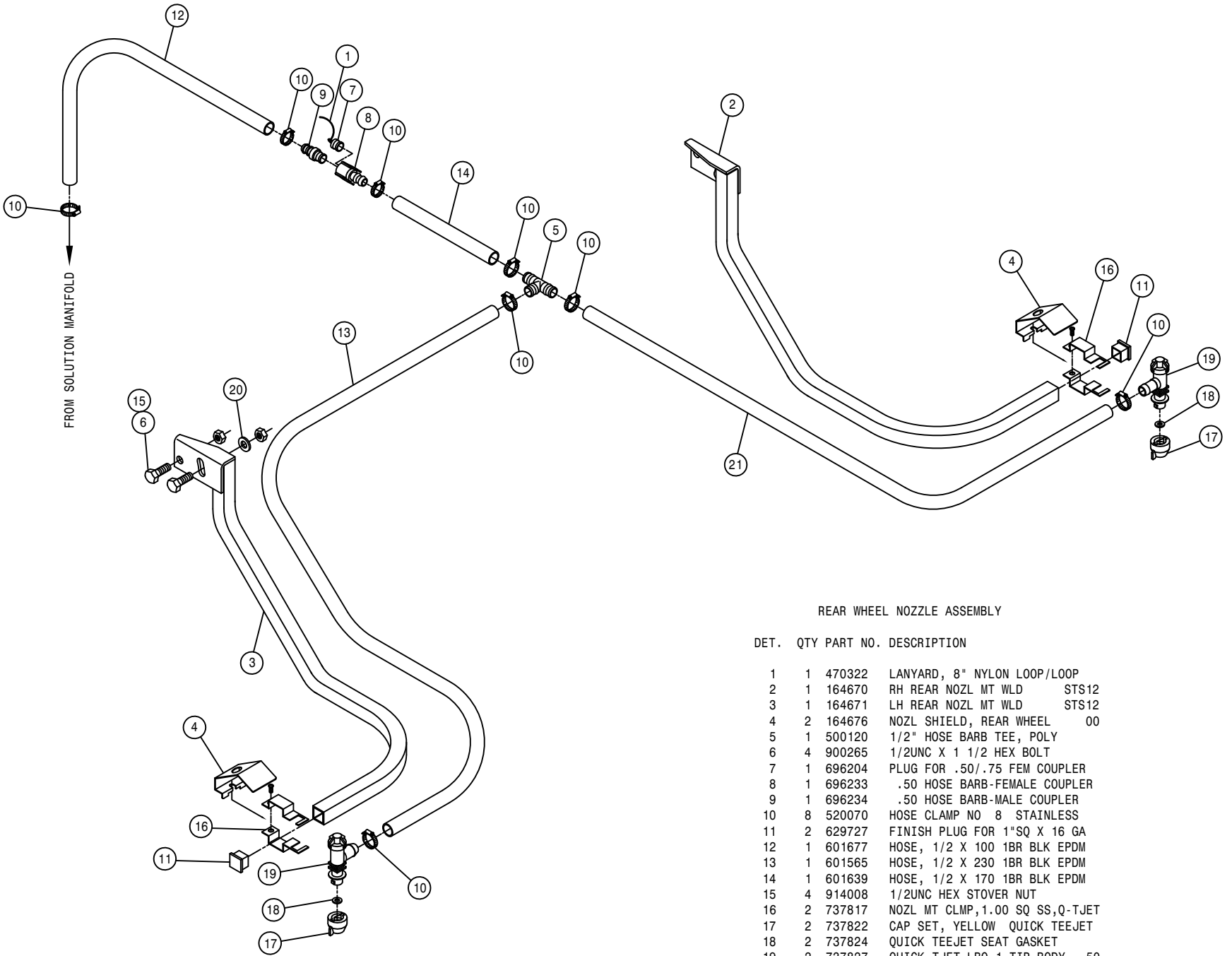

REAR WHEEL NOZZLE ASSEMBLY

DET. QTY PART NO. DESCRIPTION

DET.	QTY	PART NO.	DESCRIPTION
1	1	470322	LANYARD, 8" NYLON LOOP/LOOP
2	1	164670	RH REAR NOZL MT WLD STS12
3	1	164671	LH REAR NOZL MT WLD STS12
4	2	164676	NOZL SHIELD, REAR WHEEL 00
5	1	500120	1/2" HOSE BARB TEE, POLY
6	4	900265	1/2UNC X 1 1/2 HEX BOLT
7	1	696204	PLUG FOR .50/.75 FEM COUPLER
8	1	696233	.50 HOSE BARB-FEMALE COUPLER
9	1	696234	.50 HOSE BARB-MALE COUPLER
10	8	520070	HOSE CLAMP NO 8 STAINLESS
11	2	629727	FINISH PLUG FOR 1"SQ X 16 GA
12	1	601677	HOSE, 1/2 X 100 1BR BLK EPDM
13	1	601565	HOSE, 1/2 X 230 1BR BLK EPDM
14	1	601639	HOSE, 1/2 X 170 1BR BLK EPDM
15	4	914008	1/2UNC HEX STOVER NUT
16	2	737817	NOZL MT CLMP,1.00 SQ SS,Q-TJET
17	2	737822	CAP SET, YELLOW QUICK TEEJET
18	2	737824	QUICK TEEJET SEAT GASKET
19	2	737827	QUICK TJET LBO,1-TIP BODY .50
20	2	920004	1/2 SAE FLAT WASHER
21	1	601260	HOSE, 1/2 X 180 1BR EPDM

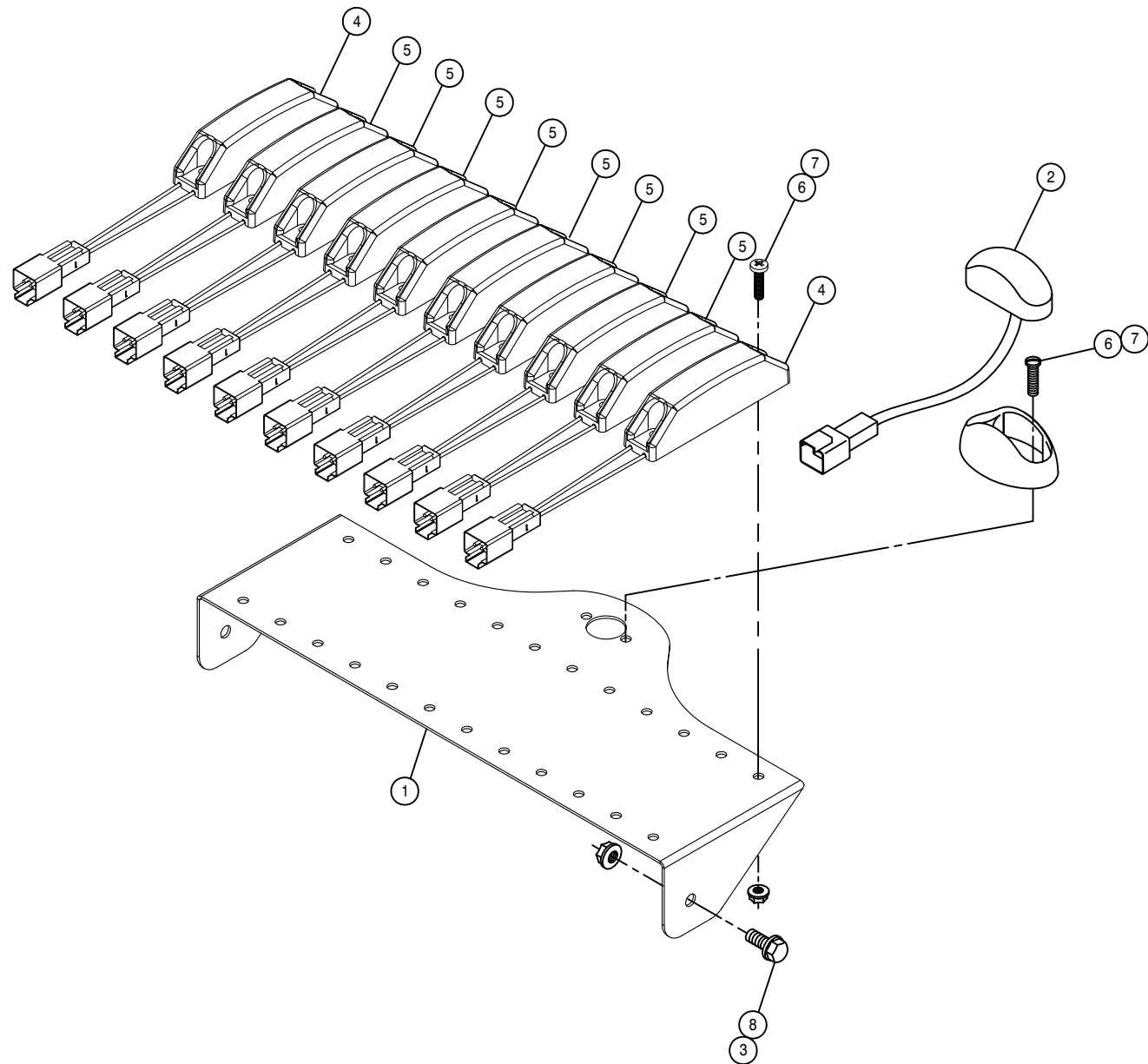

BOOM INDICATOR LIGHT ASSEMBLY

DET.	QTY	PART NO.	DESCRIPTION
	1	165008	BOOM INDICATOR LIGHT MT 05
	1	293817	MASTER SPRAY LIGHT ASSY,STS 05
	2	470121	1/4UNC HEX FLANGE LOCK NUT
	2	291325	AMBER LAMP,4" DT DEUTSCH
	8	291326	RED LAMP,4" DT DEUTSCH
	16	472235	10-32 X 3/4 PHIL PAN MACH SCR
	16	470175	10-32 HEX FLANGE LOCK NUT
	2	470118	1/4UNC X 3/4 FLANGE HEX BOLT

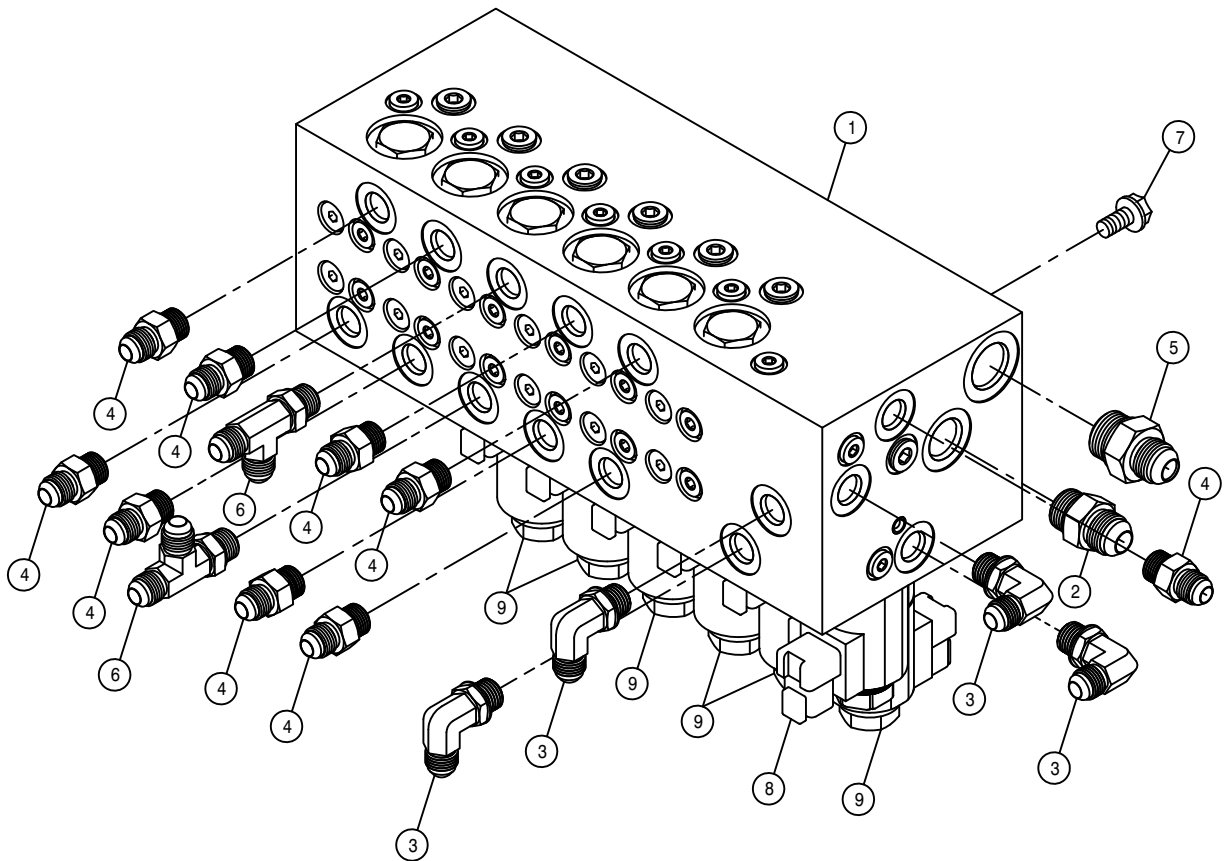

BOOM MANIFOLD ASSEMBLY

DET. QTY PART NO. DESCRIPTION

1	1	606272	VALVE, LOAD SENSE BOOM SAUER
2	1	611125	3/4MJIC-3/4MOR ADPTR
3	4	618119	9/16MJIC-90-9/16MOR LBO
4	9	618126	9/16MJIC-9/16MOR ADPTR
5	1	618327	3/4MJIC-7/8MOR ADPTR
6	2	618444	9/16MOR RUN TEE-9/16MJIC
7	4	900128	3/8UNC X 3/4 HEX BOLT
8	1	606303	CARTRIDGE, SV10, FOR VLV 606272
9	6	606304	CARTRIDGE, PSV10, FOR VLV 606272

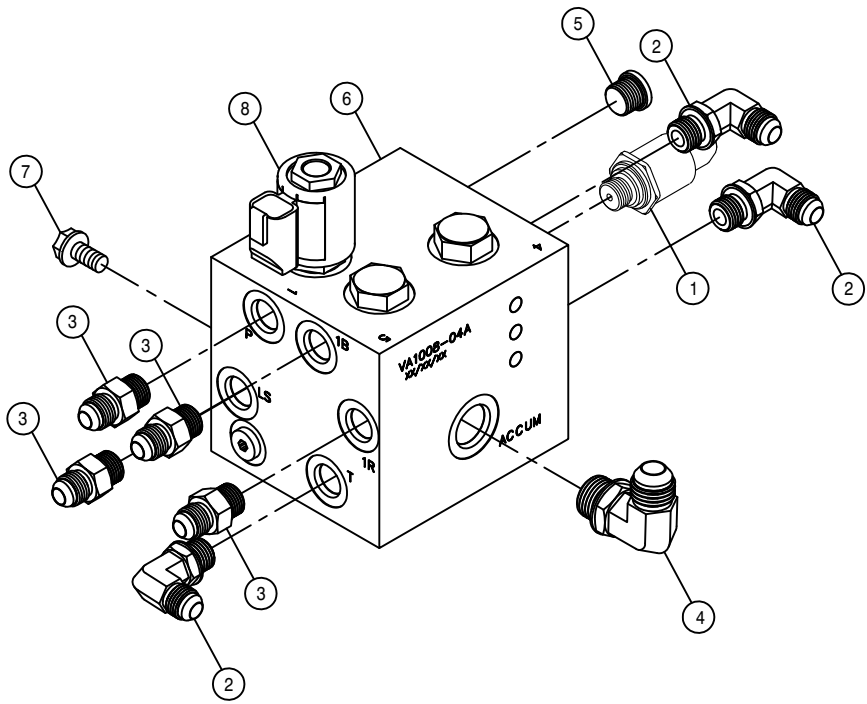

BOOM BREAKAWAY MANIFOLD ASSEMBLY

DET.	QTY	PART NO.	DESCRIPTION
	1	606347	PRESSURE TRANSDUCER, 7500PSI
	3	618119	9/16MJIC-90-9/16MOR LBO
	4	618126	9/16MJIC-9/16MOR ADPTR
	1	618241	3/4MJIC-90-3/4MOR LBO
	1	618754	9/16MOR PLUG, HEX SOCKET
	1	606248	90° BREAKAWAY VLV, STS PWRSYS
	2	900128	3/8UNC X 3/4 HEX BOLT
	1	606266	#8 COIL W/DEUTSCH

QUICK ATTACH LEVER ASSEMBLY

DET. QTY PART NO. DESCRIPTION

1	1	361742	MAINFRAME WLD STS 10/12	07
2	1	361665	RH Q-ATTACH LOCK WLD, STS	04
3	1	361666	LH Q-ATTACH LOCK WLD, STS	04
4	1	361670	RH Q-ATTACH LOCK PIN WLD, STS04	
5	1	361671	LH Q-ATTACH LOCK PIN WLD, STS04	
6	2	473805	ROLL PIN, 1/4 X 1 1/2	
7	2	482018	SPRING, 1.00 X 12.00 COMPRSN	
8	2	483055	.771ID-1.250OD-.135T MACH WASH	
9	2	629765	CAPPLUGS PLUG, 1 1/2"RD, BLK POLY	
10	4	900130	3/8UNC X 1 1/4 SER FLANGE BOLT	
11	4	914004	3/8UNC HEX STOVER NUT	
12	4	920002	3/8 SAE FLAT WASHER	
13	2	473850	ROLL PIN, 1/4 X 1"	

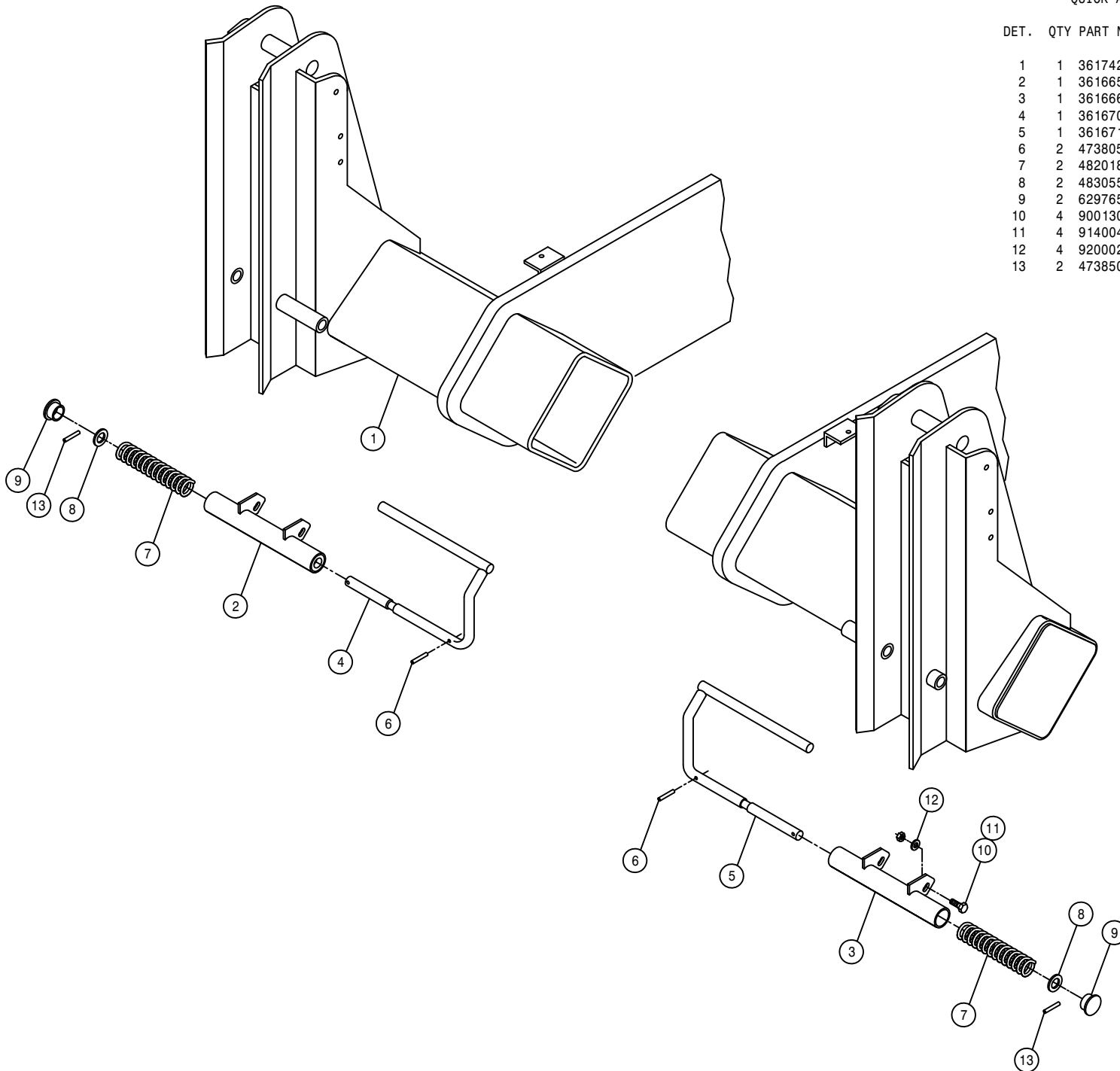

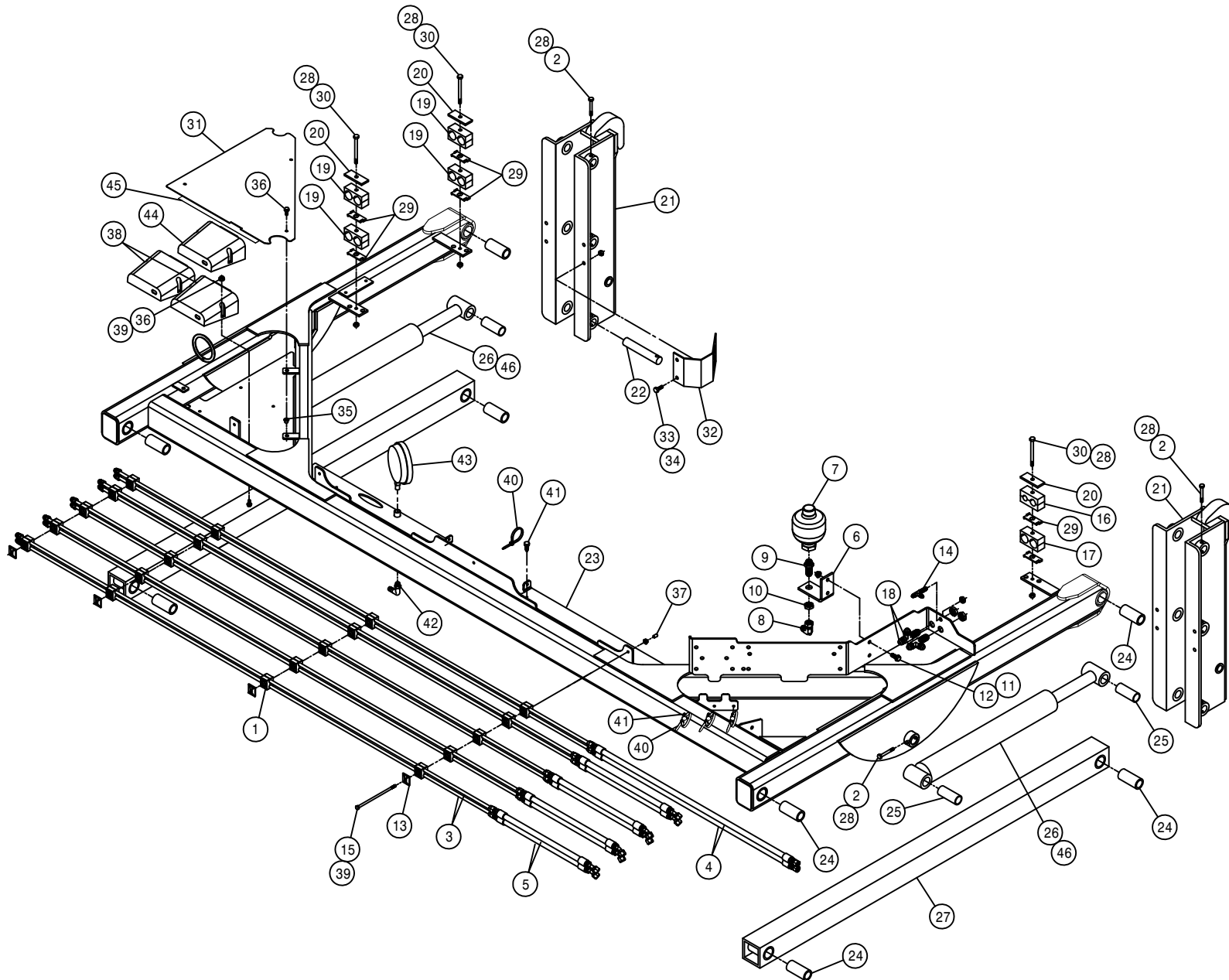

LIFTARM ASSEMBLY

DET.	QTY	PART NO.	DESCRIPTION
1	20	470473	TUBE CLAMP, HVY DTY .375-.375
2	8	900086	5/16UNC X 2 1/4 HEX BOLT
3	10	615852	LIFTARM HYD TUBE ASSY,STLSLS 07
4	2	616304	06-451TC-06FJX-06FJX-36 H/A
5	8	616316	06-451TC-06FJX-06FJX45-18 H/A
6	1	165027	ACCUMULATOR MT, GST-ST5 07
7	1	470444	ACCUMULATOR, 30CI 1508 PSI
8	1	618609	3/4MJIC-90-3/4FJIC SWIV LBO
9	1	618743	3/4MOR-3/4MJIC BLKHD, .040 ORF
10	1	618744	3/4-16 BULKHEAD LOCKNUT
11	2	470087	3/8UNC HEX FLANGE LOCK NUT
12	2	470460	3/8UNC X 1 SERR FLANGE BOLT
13	4	470474	COVER PLATE FOR 470473 CLAMP
14	1	618748	7/16MJIC BLKHD RUN TEE
15	4	900032	1/4UNC X 6 1/2" HEX BOLT
16	1	470270	HOSE CLAMP BODY, .530-.680
17	1	470274	TUBE CLAMP BODY, .750-.750
18	2	618749	3/4MJIC BLKHD RUN TEE
19	4	470275	TUBE CLAMP BODY,1.000-1.000
20	3	470276	CLAMP COVER PLATE,SNGL, 2.55LG
21	2	164800	QUICK ATTACH PLT WLD STS 04
22	12	164452	LIFT ARM MT PIVOT PIN,ST512 04
23	1	165021	UPPER LIFT ARM WLD, STLSLS 06
24	8	121107	BEARING,1.006-1.368-3.00PLYGON
25	4	121109	LIFT CYL BRG, .313 POLYGON
26	2	621556	HYD CYL, 2.50 X 18.00 X 1.500
27	2	164450	LWR LIFTARM WLD, STS 00
28	11	914002	5/16UNC HEX STOVER NUT
29	6	470281	STACK BOLT SAFETY LOCK PLATE
30	3	900076	5/16UNC X 4" HEX BOLT
31	1	165006	UPPER LIFTARM BUSS COVER,ST505
32	1	165741	RECEPTACLE MT,ST5 BOOMS '10
33	2	900129	3/8UNC X 1" SERR FLANGE BOLT
34	2	914004	3/8UNC HEX STOVER NUT
35	3	470380	1/4-20 NUTSERT .027-.165 STL
36	9	470118	1/4UNC X 3/4 FLANGE HEX BOLT
37	4	629770	CAPPLUGS CAP, .234 X .500 VINYL
38	2	292017	IQAN-XS2 MODULE
39	10	470121	1/4UNC HEX FLANGE LOCK NUT
40	7	470154	CABLE TIE, 11.75" BLK PLASTIC
41	7	470432	PUSH MT BASE FOR PLASTIC TIE
42	1	618556	1/4NPT-90-1/2 HOSE BARB,POLY
43	1	690359	PRESSURE GA GLYCERI 100 PSI
44	1	292016	IQAN-XA2 MODULE
45	1	650228	DECAL,BM MODULE ST510/12,90 '10
46	2	621557	REPAIR KIT,HYD CYL 621556

TRANSOM ASSEMBLY

DET. QTY PART NO. DESCRIPTION

DET.	QTY	PART NO.	DESCRIPTION
1	4	470012	COTTER PIN 5/16 X 2" LG,316 SS
2	4	121029	JOURNAL BRG, 1.00 ID X 1.00 LG
3	2	471005	GREASE ZERK, 1/4 28 X 1/2
4	16	473842	1/4UNC LOCK NUT,CNTR POINT SS
5	8	473979	1/4UNC-1 1/8ID-1 1/2U-BOLTSQSS
6	2	900284	1/2UNC X 4 3/4 HEX BOLT
7	2	914008	1/2UNC HEX STOVER NUT
8	1	165825	TRANSOM WLD STS12 '10
9	1	164469	RH TRANSOM PIVOT TUBE WLD
10	2	164481	INNER TRANSOM PIVOT TUBE
11	2	121103	TRANSOM PIVOT BRG, LWR,POLYGON
12	1	164470	LH TRANSOM PIVOT TUBE WLD
13	4	121104	BOOM PIVOT BEARING, POLYGON
14	2	164482	WASH: 11GA X 2.69 X 4.00
15	4	629727	FINISH PLUG FOR 1"SQ X 16 GA
16	8	914010	5/8UNC HEX STOVER NUT
17	1	164485	HOSE SUPPORT WLD
18	1	165828	FOLD CYL TRUNNION MT WLD '10
19	2	164491	1.000 SQ X 16GA X 124.00 C/L
20	2	121101	TRANSOM PIVOT BRG,TOP POLYGON
21	4	900086	5/16UNC X 2 1/4 HEX BOLT
22	4	914002	5/16UNC HEX STOVER NUT
23	2	914004	3/8UNC HEX STOVER NUT
24	2	164642	2.875 OD X 16GA X 18.00 C/L
25	2	164498	BOOM FOLD CYL PIN WLD
26	2	164496	LEVEL CYL PIN WLD, TRANSOM END
27	4	920008	1" SAE FLAT WASHER
28	2	621558	HYD CYL, 3.00 X 11.00 X 1.380
29	2	621560	HYD CYL, 2.50 X 21.00 X 1.380
30	8	900333	5/8UNC X 1 1/2 HEX BOLT
31	2	900129	3/8UNC X 1" SERR FLANGE BOLT
32	2	164641	1.750 OD X 14GA X 3.81 C/L
33	2	165027	ACCUMULATOR MT, GST-ST5 07
34	2	470444	ACCUMULATOR, 30CI 1508 PSI
35	2	618609	3/4MJIC-90-3/4FJIC SWIV LBO
36	2	618743	3/4MOR-3/4MJIC BLKHD, .040 ORF
37	2	618744	3/4-16 BULKHEAD LOCKNUT
38	4	470087	3/8UNC HEX FLANGE LOCK NUT
39	4	900130	3/8UNC X 1 1/4 SER FLANGE BOLT
40	1	291902	RH WORKLIGHT, TRAPEZOID GLASS
41	1	291903	LH WORKLIGHT, TRAPEZOID GLASS

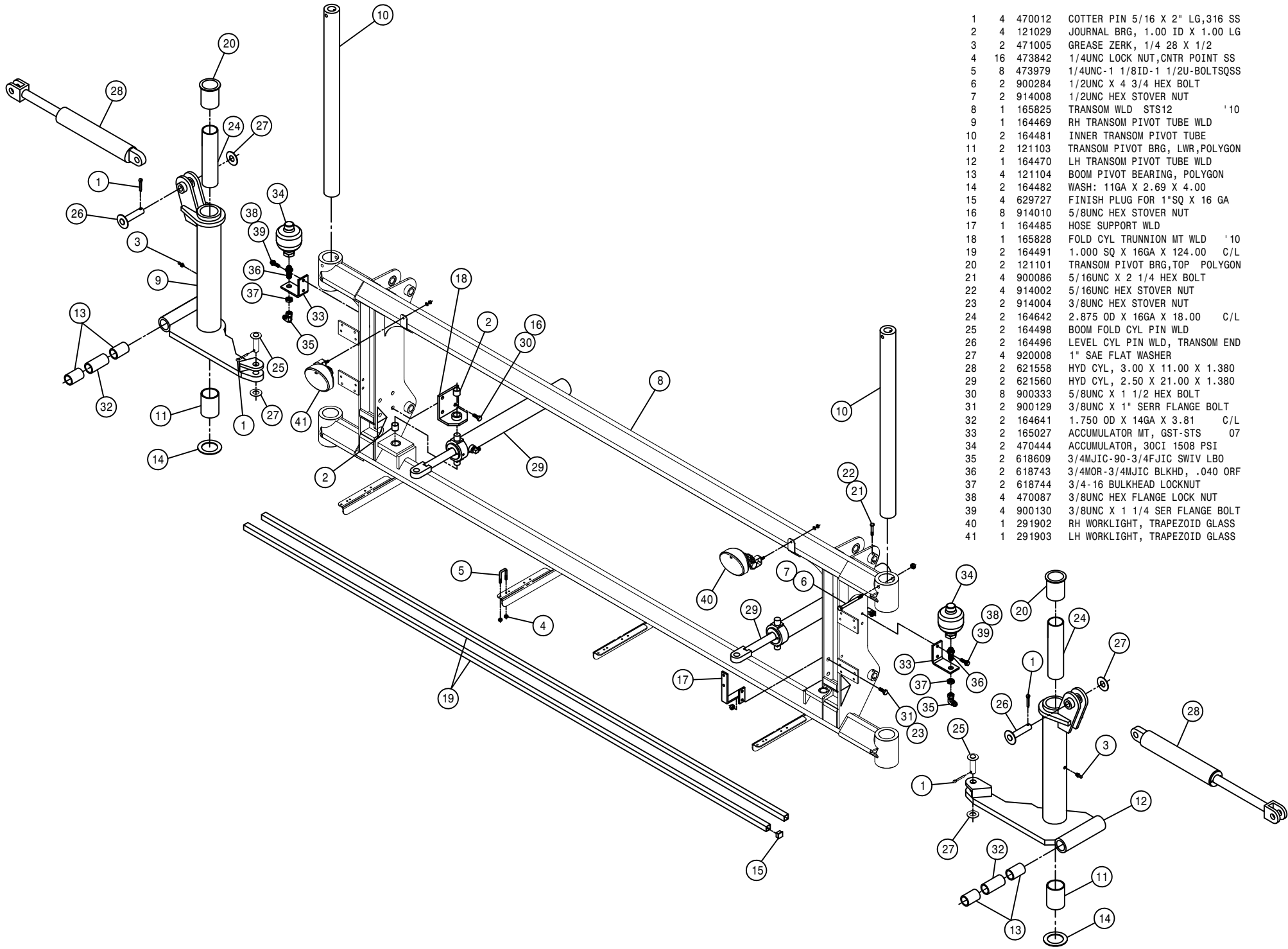

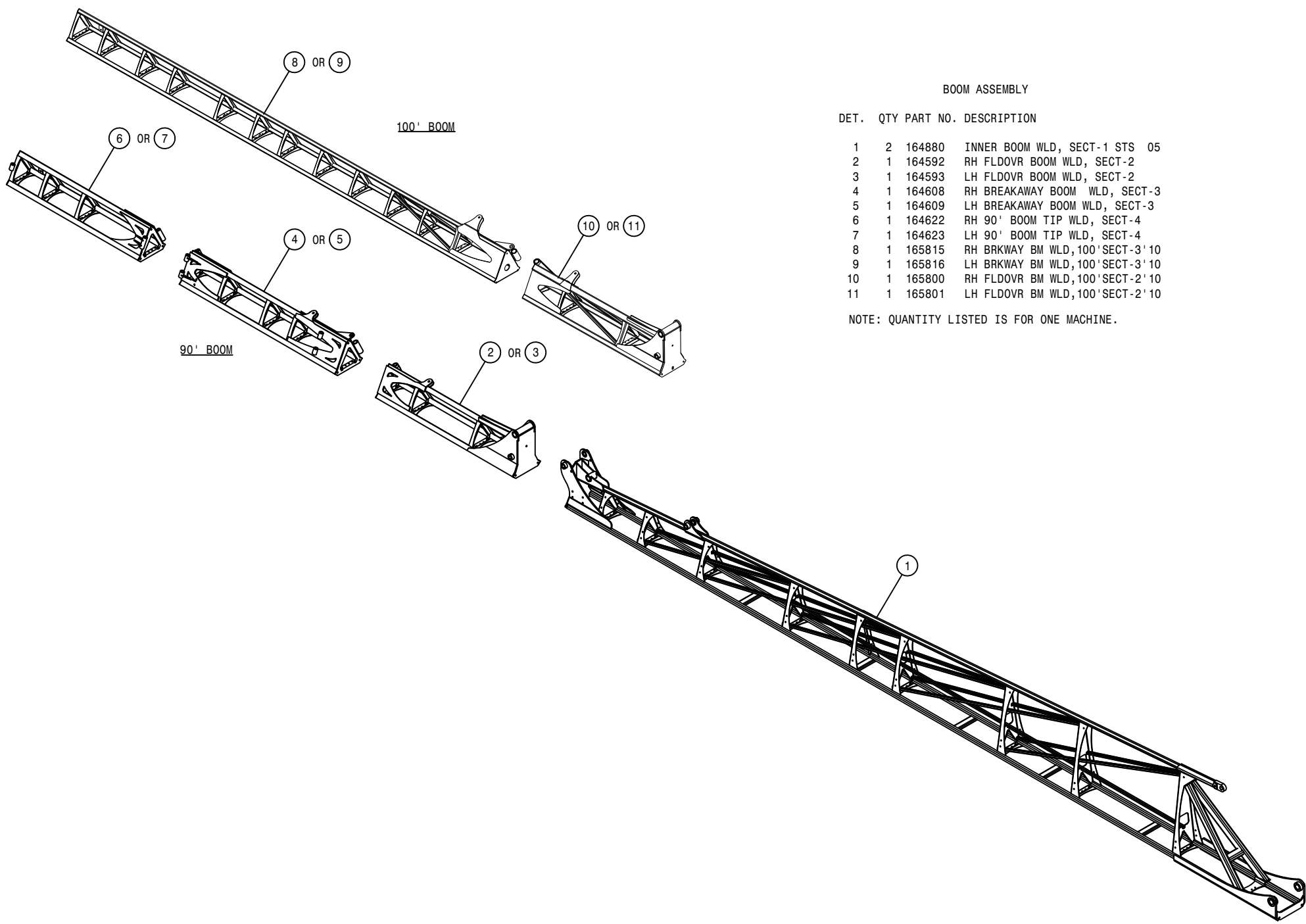

BOOM ASSEMBLY

DET.	QTY	PART NO.	DESCRIPTION
1	2	164880	INNER BOOM WLD, SECT-1 STS 05
2	1	164592	RH FLDOVR BOOM WLD, SECT-2
3	1	164593	LH FLDOVR BOOM WLD, SECT-2
4	1	164608	RH BREAKAWAY BOOM WLD, SECT-3
5	1	164609	LH BREAKAWAY BOOM WLD, SECT-3
6	1	164622	RH 90' BOOM TIP WLD, SECT-4
7	1	164623	LH 90' BOOM TIP WLD, SECT-4
8	1	165815	RH BRKWAY BM WLD, 100' SECT-3' 10
9	1	165816	LH BRKWAY BM WLD, 100' SECT-3' 10
10	1	165800	RH FLDOVR BM WLD, 100' SECT-2' 10
11	1	165801	LH FLDOVR BM WLD, 100' SECT-2' 10

NOTE: QUANTITY LISTED IS FOR ONE MACHINE.

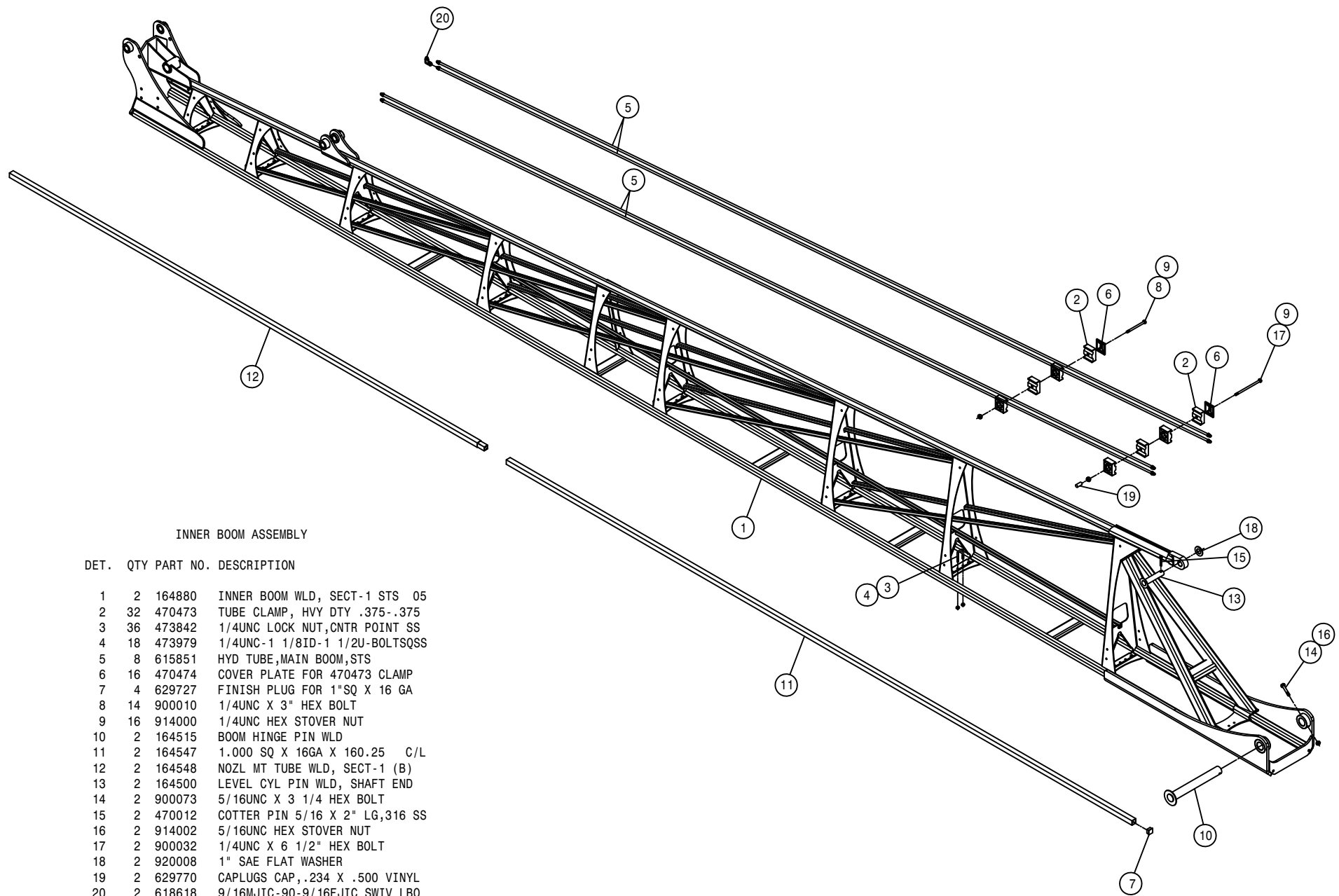

INNER BOOM ASSEMBLY

DET. QTY PART NO. DESCRIPTION

DET.	QTY	PART NO.	DESCRIPTION
1	2	164880	INNER BOOM WLD, SECT-1 STS 05
2	32	470473	TUBE CLAMP, HVY DTY .375-.375
3	36	473842	1/4UNC LOCK NUT,CNTR POINT SS
4	18	473979	1/4UNC-1 1/8ID-1 1/2U-BOLTSQSS
5	8	615851	HYD TUBE,MAIN BOOM,STS
6	16	470474	COVER PLATE FOR 470473 CLAMP
7	4	629727	FINISH PLUG FOR 1"SQ X 16 GA
8	14	900010	1/4UNC X 3" HEX BOLT
9	16	914000	1/4UNC HEX STOVER NUT
10	2	164515	BOOM HINGE PIN WLD
11	2	164547	1.000 SQ X 16GA X 160.25 C/L
12	2	164548	NOZL MT TUBE WLD, SECT-1 (B)
13	2	164500	LEVEL CYL PIN WLD, SHAFT END
14	2	900073	5/16UNC X 3 1/4 HEX BOLT
15	2	470012	COTTER PIN 5/16 X 2" LG,316 SS
16	2	914002	5/16UNC HEX STOVER NUT
17	2	900032	1/4UNC X 6 1/2" HEX BOLT
18	2	920008	1" SAE FLAT WASHER
19	2	629770	CAPPLUGS CAP,.234 X .500 VINYL
20	2	618618	9/16MJIC-90-9/16FJIC SWIV LBO

NOTE: QUANTITY LISTED IS FOR ONE MACHINE.

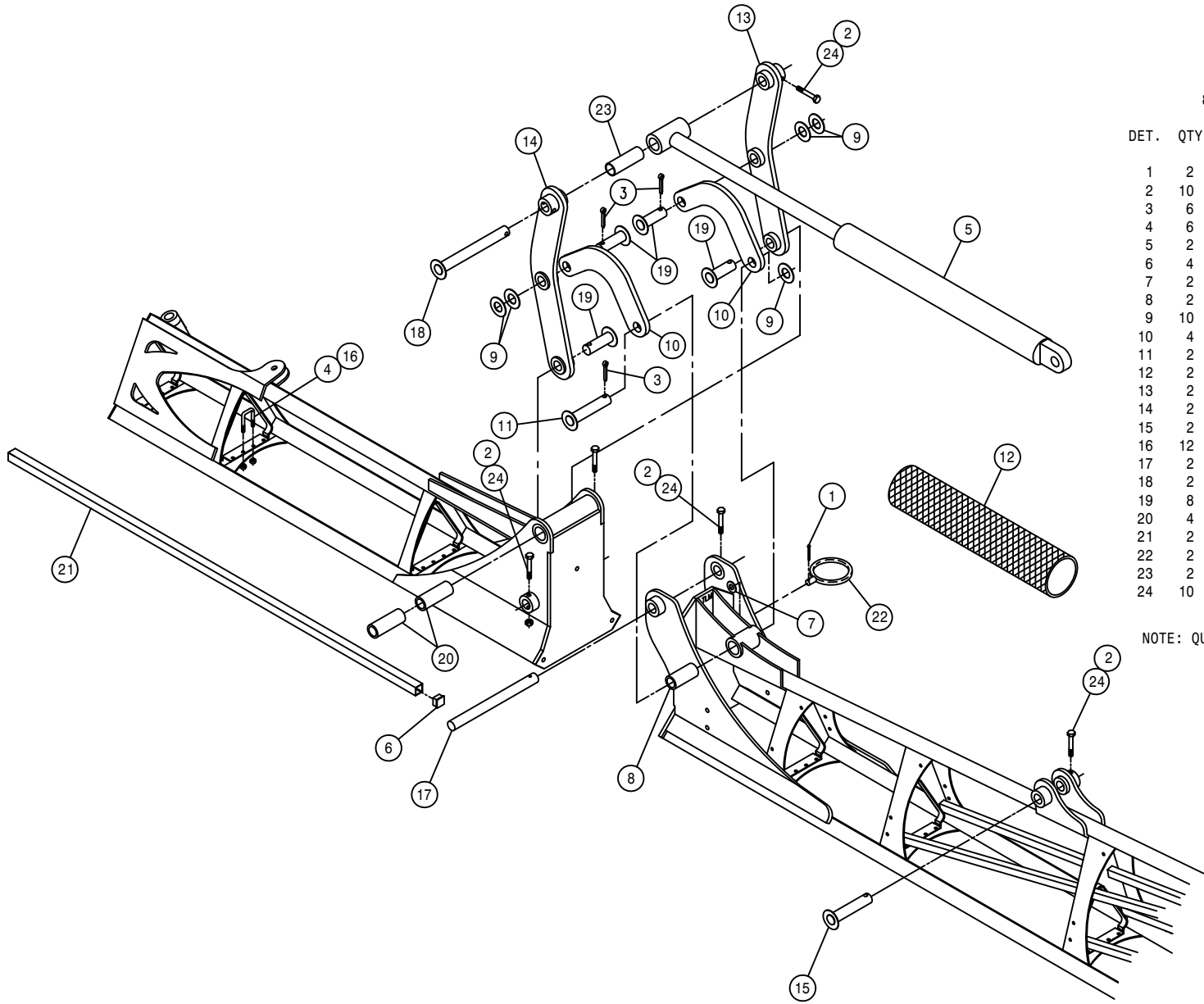

80'-90' BOOM HINGE ASSEMBLY

DET.	QTY	PART NO.	DESCRIPTION
	1	2 390984	COTTER PIN 1/8 X 1 1/4
	2	10 914002	5/16UNC HEX STOVER NUT
	3	6 470012	COTTER PIN 5/16 X 2" LG,316 SS
	4	6 473979	1/4UNC-1 1/8ID-1 1/2U-BOLTSQSS
	5	2 621562	HYD CYL, 2.25 X 21.00 X 1.380
	6	4 629727	FINISH PLUG FOR 1"SQ X 16 GA
	7	2 920004	1/2 SAE FLAT WASHER
	8	2 121121	BEARING,1.006-1.368-3.60POLYGON
	9	10 920008	1" SAE FLAT WASHER
	10	4 164643	XK402 TOP ARM(LEFT) 10.35 CNTR
	11	2 165834	PIN WLD, 1.00 X 5.14
	12	2 470378	SIDEWINDER SLEEVE,14.06 X 21"
	13	2 165836	RH FOLD-OVER BOOMERANG WLD
	14	2 165837	LH FOLD-OVER BOOMERANG WLD
	15	2 164522	BOOM FOLD CYL PIN WLD
	16	12 473842	1/4UNC LOCK NUT,CNTR POINT SS
	17	2 164678	BOOM FOLD PIVOT PIN, STS 05
	18	2 164520	BOOM CYL PIVOT PIN WLD
	19	8 164524	BOOMERANG CNTR PIVOT PIN WLD
	20	4 121106	BOOM FOLD BRG, POLYGON
	21	2 164551	1.000 SQ X 16GA X 58.50 C/L
	22	2 164517	HOSE SUPPORT RING WLD
	23	2 121108	OUTR BOOM FOLD CYL BRG,POLYGON
	24	10 900086	5/16UNC X 2 1/4 HEX BOLT

NOTE: QUANTITY LISTED IS FOR ONE MACHINE.

DET. QTY PART NO. DESCRIPTION

DET.	QTY	PART NO.	DESCRIPTION
1	36	473842	1/4UNC LOCK NUT,CNTR POINT SS
2	18	473979	1/4UNC-1 1/8ID-1 1/2U-BOLTSQSS
3	6	470011	COTTER PIN 5/32 X 1 1/2,316 SS
4	2	621066	BOOM BREAKAWAY CYL ASSY STS 03
5	12	629727	FINISH PLUG FOR 1"SQ X 16 GA
6	1	164592	RH FLDOVR BOOM WLD, SECT-2
7	1	164593	LH FLDOVR BOOM WLD, SECT-2
8	1	164608	RH BREAKAWAY BOOM WLD, SECT-3
9	1	164609	LH BREAKAWAY BOOM WLD, SECT-3
10	1	164622	RH 90' BOOM TIP WLD, SECT-4
11	1	164623	LH 90' BOOM TIP WLD, SECT-4
12	4	164637	BOOM TIP SECTION PIN WLD
13	8	121110	BREAKAWAY BRG, POLYGON
14	2	164553	1.000 SQ X 16GA X 53.00 C/L
15	2	164552	1.000 SQ X 16GA X 65.50 C/L
16	2	900265	1/2UNC X 1 1/2 HEX BOLT
17	4	900267	1/2UNC X 2" HEX BOLT
18	4	914008	1/2UNC HEX STOVER NUT
19	2	164526	BOOM BREAKAWAY PIVOT PIN WLD
20	2	164778	1.000 SQ X 16GA X 114.00 C/L
21	1	165815	RH BRKWAY BM WLD,100'SECT-3' 10
22	1	165816	LH BRKWAY BM WLD,100'SECT-3' 10
23	1	165800	RH FLDOVR BM WLD,100'SECT-2' 10
24	1	165801	LH FLDOVR BM WLD,100'SECT-2' 10
25	2	906350	3/4UNC X 6" HEX BOLT FULL
26	2	472334	3/4UNC HEX JAM NUT
27	12	920004	1/2 SAE FLAT WASHER

NOTE: QUANTITY LISTED IS FOR ONE MACHINE.

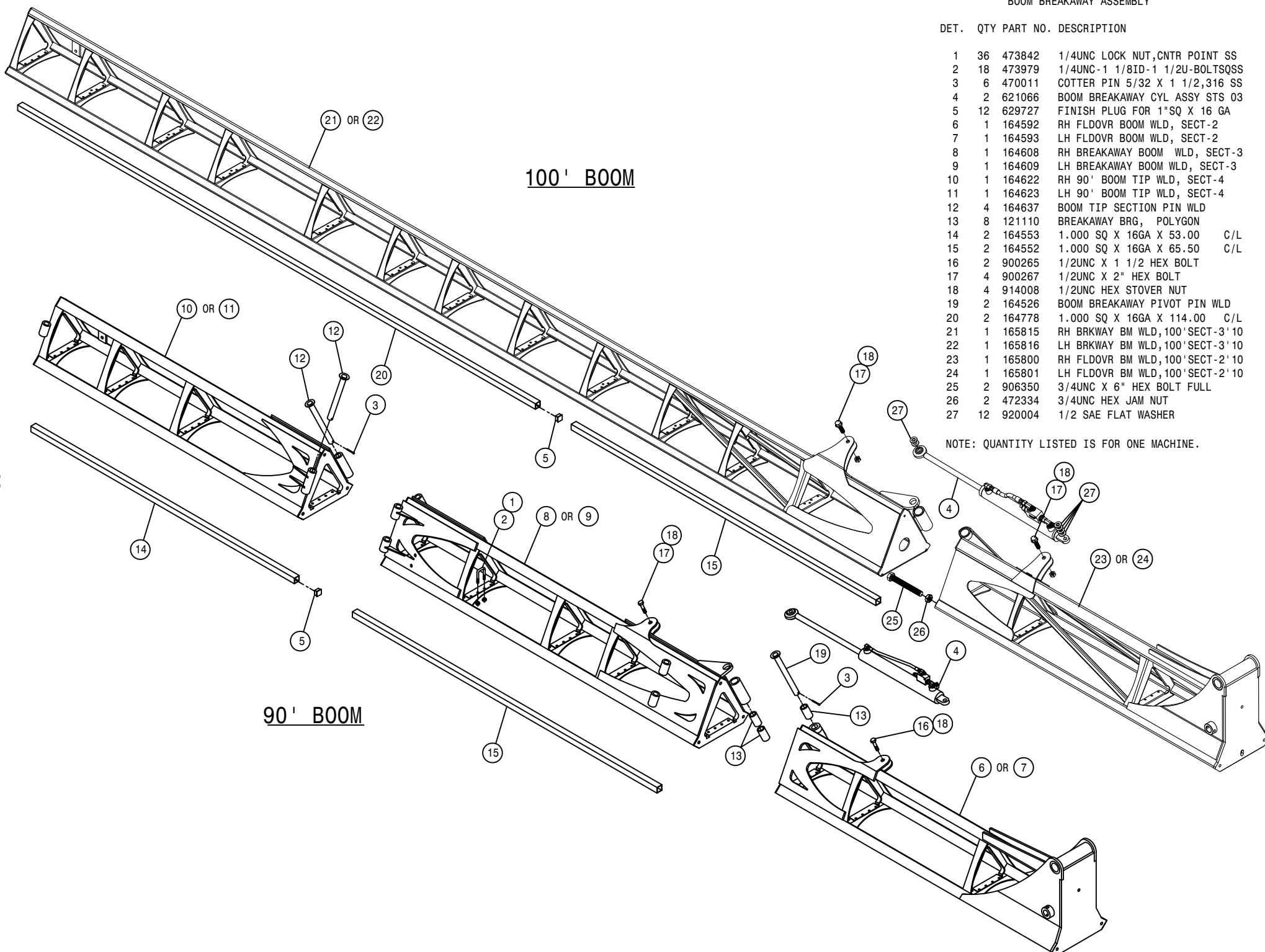

100' BOOM

90' BOOM

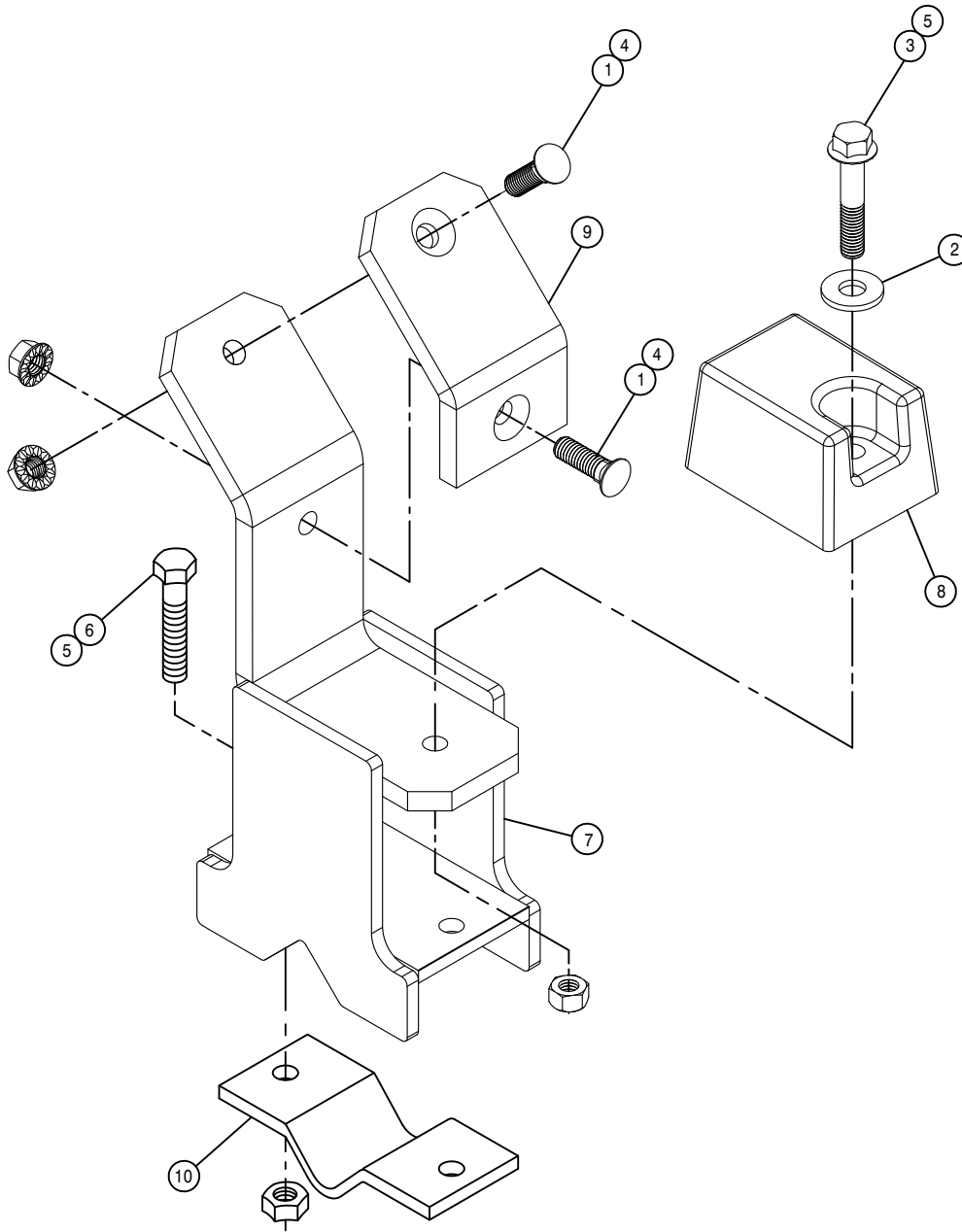

BOOM SUPPORT CRADLE ASSEMBLY, 80' - 90'

DET.	QTY	PART NO.	DESCRIPTION
1	2	470328	3/8UNC X 1 1/4 #3HD PLOW BOLT
2	1	483043	3/8 REGULAR FLAT WASHER
3	1	900133	3/8UNC X 2" SERR FLANGE BOLT
4	2	470087	3/8UNC HEX FLANGE LOCK NUT
5	3	914004	3/8UNC HEX STOVER NUT
6	2	900170	3/8UNC X 2 1/4 SER FLANGE BOLT
7	1	164811	BOOM SUPP CRADLE WLD,80/90' 04
8	1	164541	BOOM SUPPORT PAD
9	1	164542	BOOM SUPPORT CRADLE PAD
10	1	164543	BOOM SUPPORT KEEPER

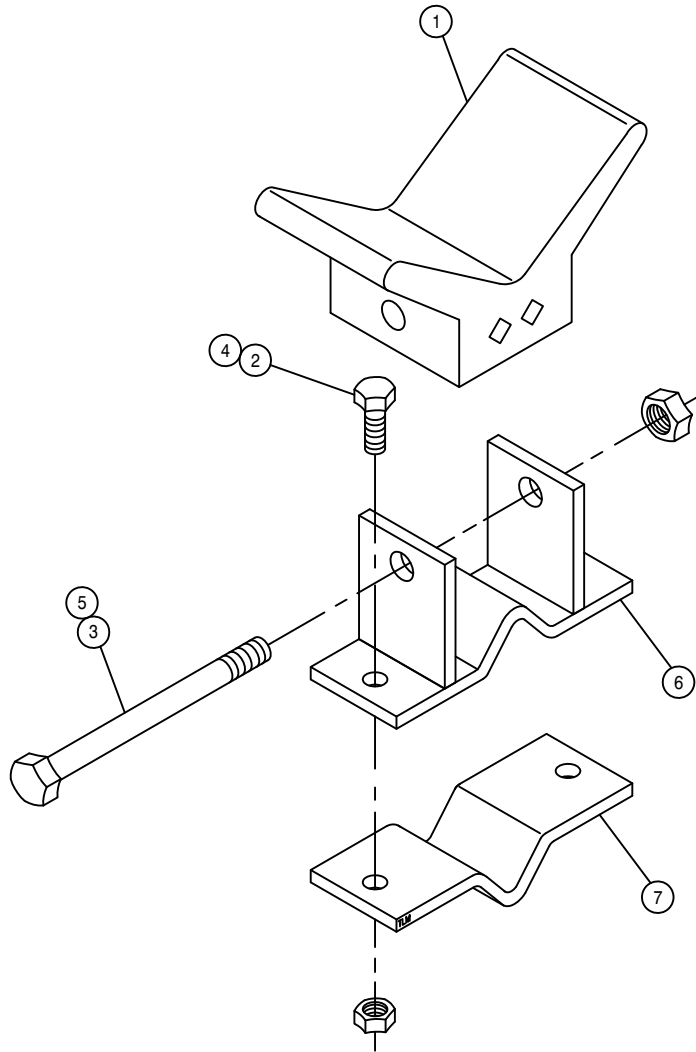

90' BOOM SUPPORT ASSEMBLY

DET. QTY PART NO. DESCRIPTION

1	1	470324	3" RUBBER BOW GUARD
2	2	900130	3/8UNC X 1 1/4 SER FLANGE BOLT
3	1	900273	1/2UNC X 3 3/4 HEX BOLT
4	2	914004	3/8UNC HEX STOVER NUT
5	1	914008	1/2UNC HEX STOVER NUT
6	1	164544	FRT BOOM SUPPORT WLD, 90' BOOM
7	1	164545	FRT BOOM SUPPORT MT

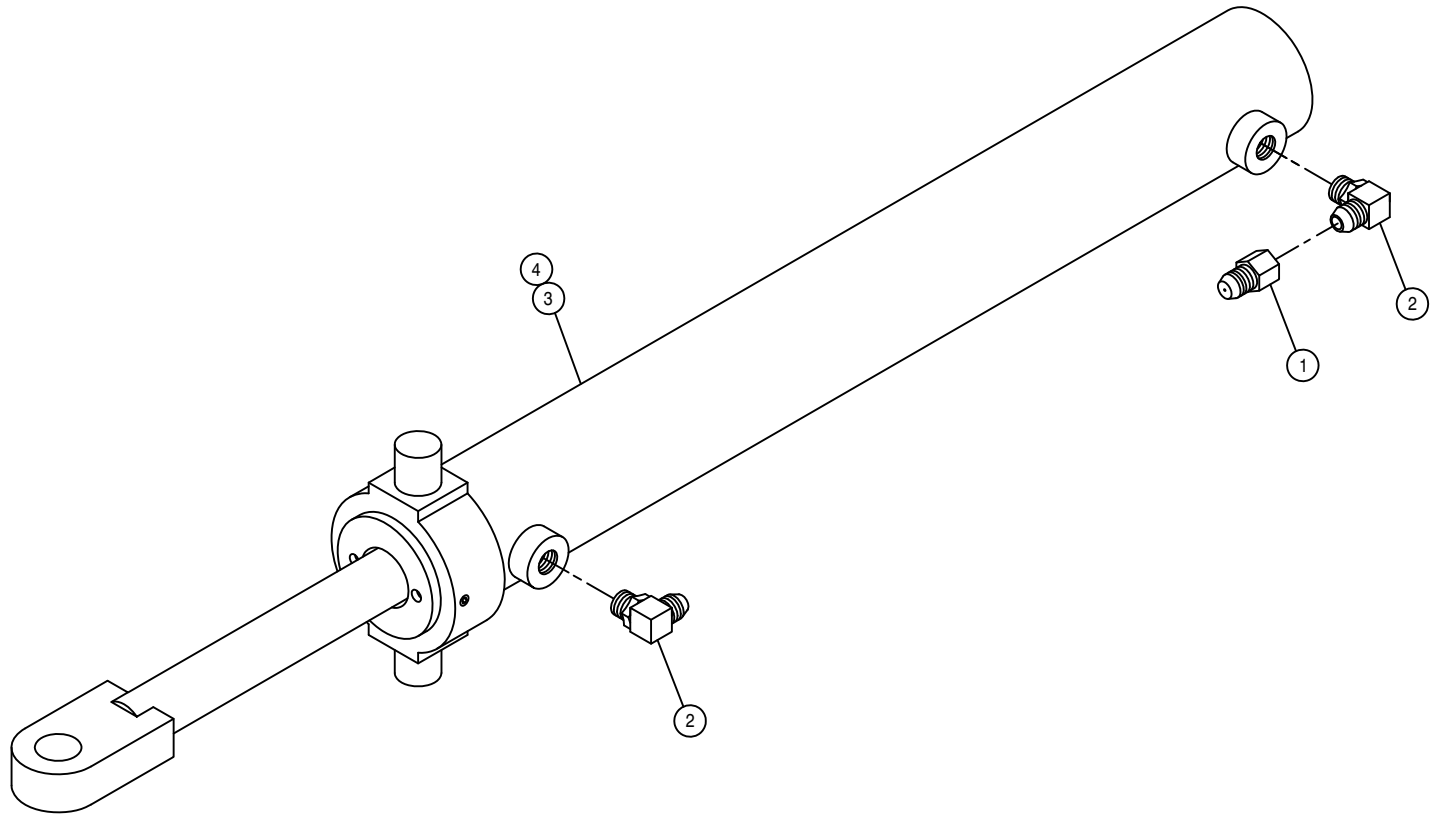

BOOM FOLD CYLINDER ASSEMBLY

DET.	QTY	PART NO.	DESCRIPTION
	1	618733	9/16JIC .042 ORIFICE ADPTR
	2	618119	9/16MJIC-90-9/16MOR LBO
	3	621560	HYD CYL, 2.50 X 21.00 X 1.380
	4	621561	REPAIR KIT, HYD CYL 621560

BOOM LEVEL CYLINDER ASSEMBLY

DET.	QTY	PART NO.	DESCRIPTION
1	1	618119	9/16MJIC-90-9/16MOR LBO
2	1	621559	REPAIR KIT, HYD CYL 621558
3	1	618689	9/16MJ-90-9/16MOR .042 CHK VLV
4	1	621558	HYD CYL, 3.00 X 11.00 X 1.380
5	1	618486	9/16FJIC SW RUN TEE-9/16MJIC

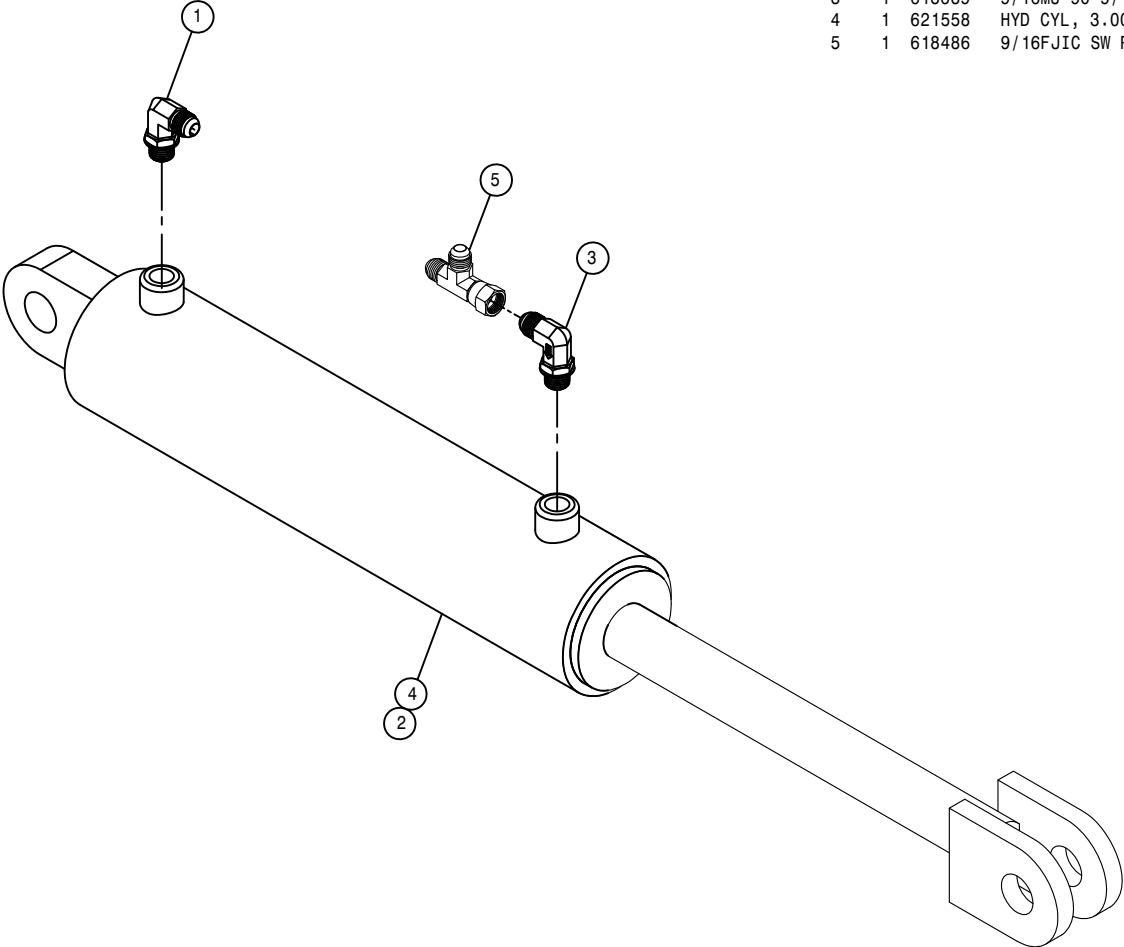

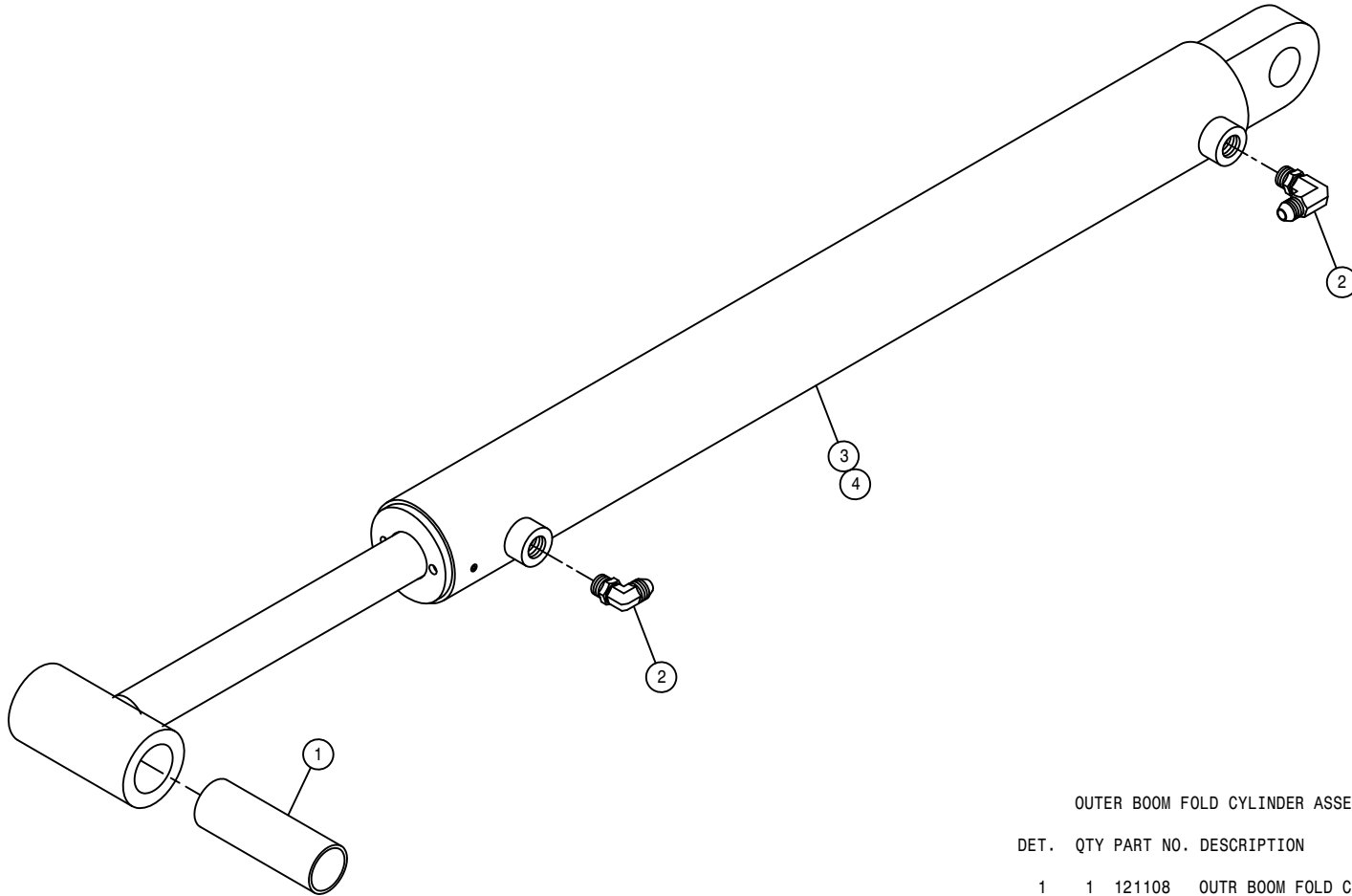

OUTER BOOM FOLD CYLINDER ASSEMBLY

DET.	QTY	PART NO.	DESCRIPTION
1	1	121108	OUTR BOOM FOLD CYL BRG,POLYGON
2	2	618688	9/16MJ-90-9/16MOR .025 CHK VLV
3	1	621562	HYD CYL , 2.25 X 21.00 X 1.380
4	1	621563	REPAIR KIT,HYD CYL 621562

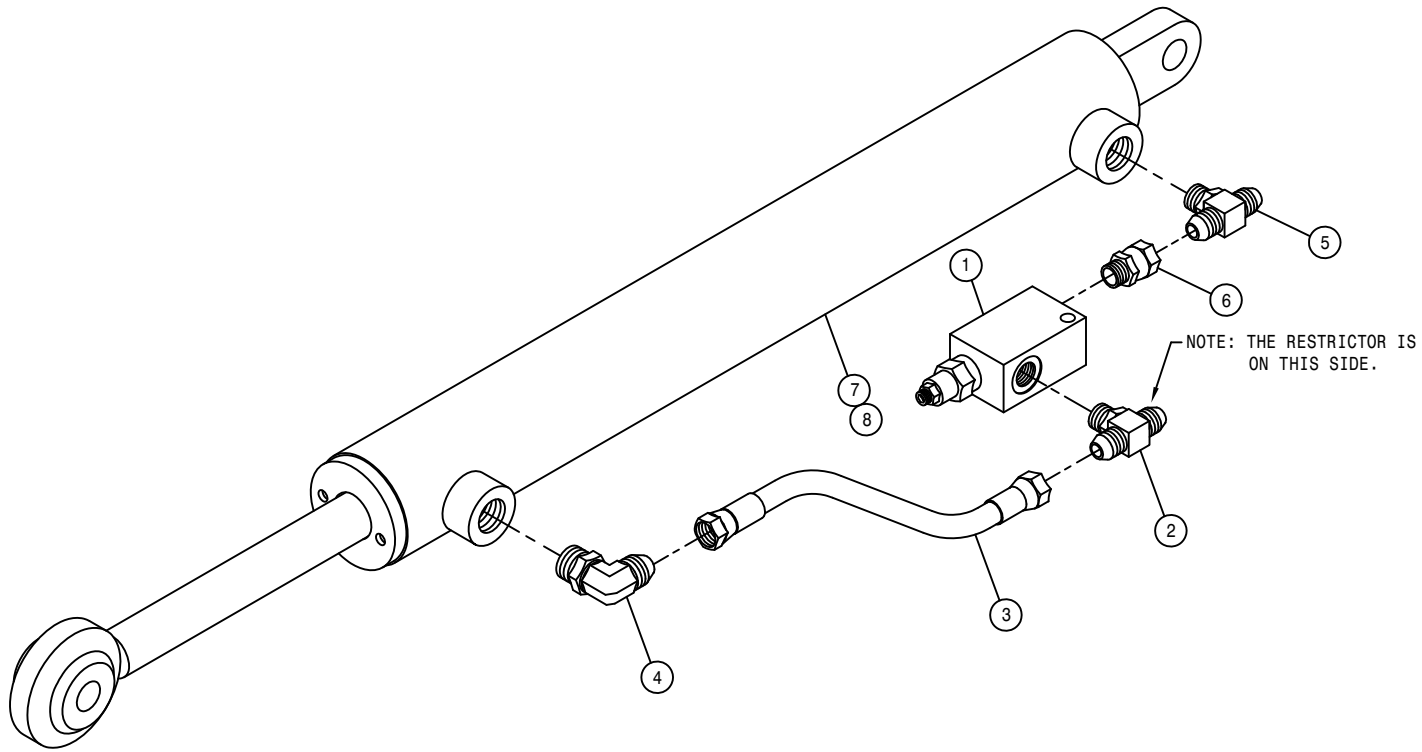

BOOM BREAKAWAY CYLINDER ASSEMBLY

DET.	QTY	PART NO.	DESCRIPTION
	1	607540	KICK-DOWN RELIEF VALVE, 800PSI
	1	614752	RESTRICTOR BR TEE ASSY, .042DIA
	1	616075	04-451TC-06FJX-06FJX-9 H/A
	1	618119	9/16MJIC-90-9/16MOR LBO
	1	618629	9/16MOR BRANCH TEE-9/16MJIC
	1	618668	9/16FJIC SWIV-9/16MOR ADPTR
	1	621554	HYD CYL, 1.50 X 12.25 X .750
	1	621555	REPAIR KIT, HYD CYL 621554

LIFT CYLINDER ASSEMBLY

DET.	QTY	PART NO.	DESCRIPTION
1	2	121109	LIFT CYL BRG, .313 POLYGON
2	1	618119	9/16MJIC-90-9/16MOR LBO
3	1	618689	9/16MJ-90-9/16MOR .042 CHK VLV
4	1	621556	HYD CYL, 2.50 X 18.00 X 1.500
5	1	621557	REPAIR KIT, HYD CYL 621556

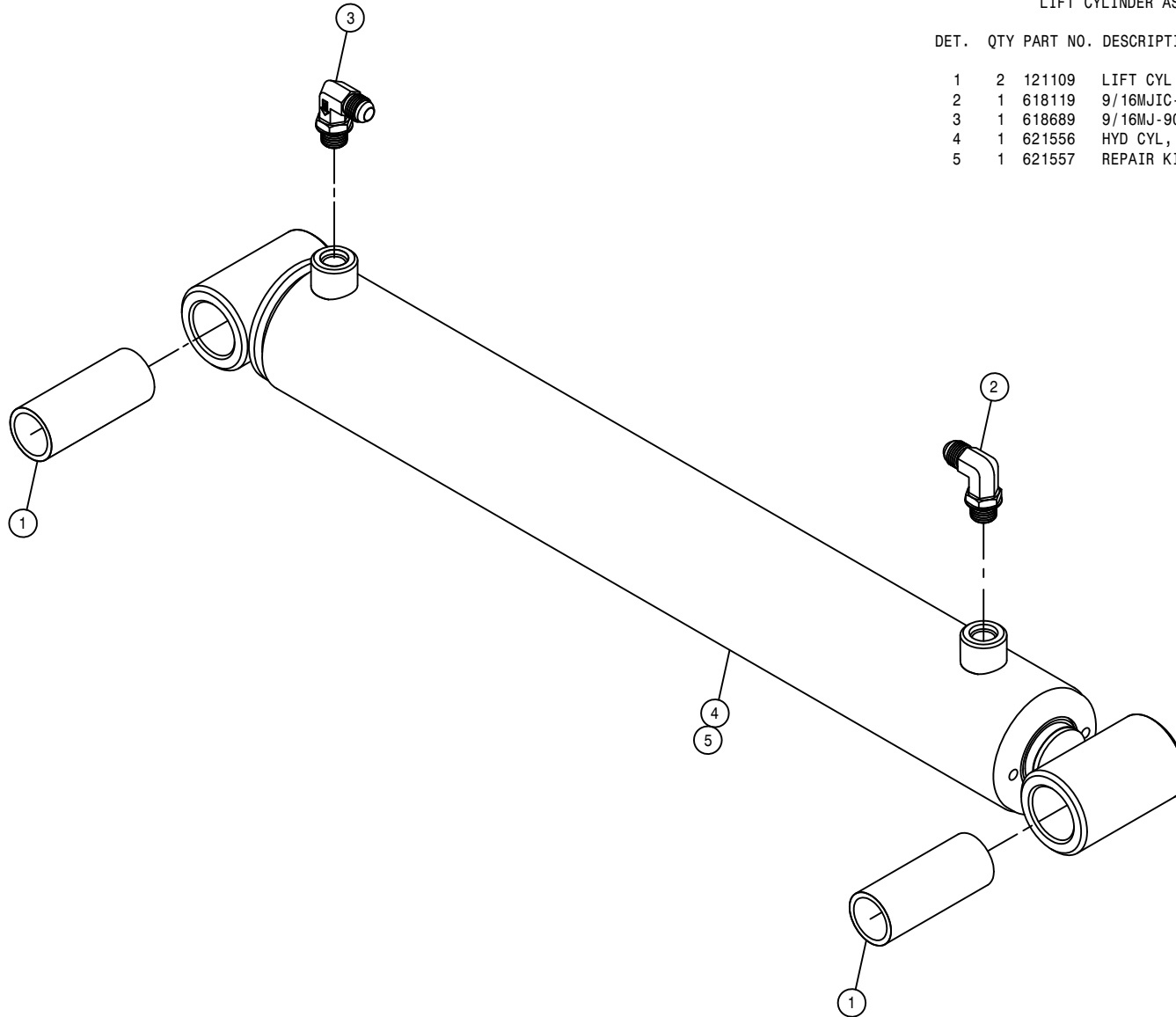

RH BOOM CRADLE ASSEMBLY 90' BOOM

DET.	QTY	PART NO.	DESCRIPTION
1	2	164513	BOOM CRADLE PAD
2	1	164512	RUBBER BUMPER, BOOM CRADLE
3	1	165041	BOOM CRADLE WLD 07
4	1	292917	LED LIGHT, AMBER W/JUMPER
5	2	470118	1/4UNC X 3/4 FLANGE HEX BOLT
6	6	920002	3/8 SAE FLAT WASHER
7	6	914004	3/8UNC HEX STOVER NUT
8	6	900133	3/8UNC X 2" SERR FLANGE BOLT
9	2	470121	1/4UNC HEX FLANGE LOCK NUT
10	4	900265	1/2UNC X 1 1/2 HEX BOLT
11	4	914008	1/2UNC HEX STOVER NUT
12	2	291904	WORKLIGHT, VERTICAL FLOOD PLAS
13	1	343689	EXTREMITY FLASHER MT, STS '11

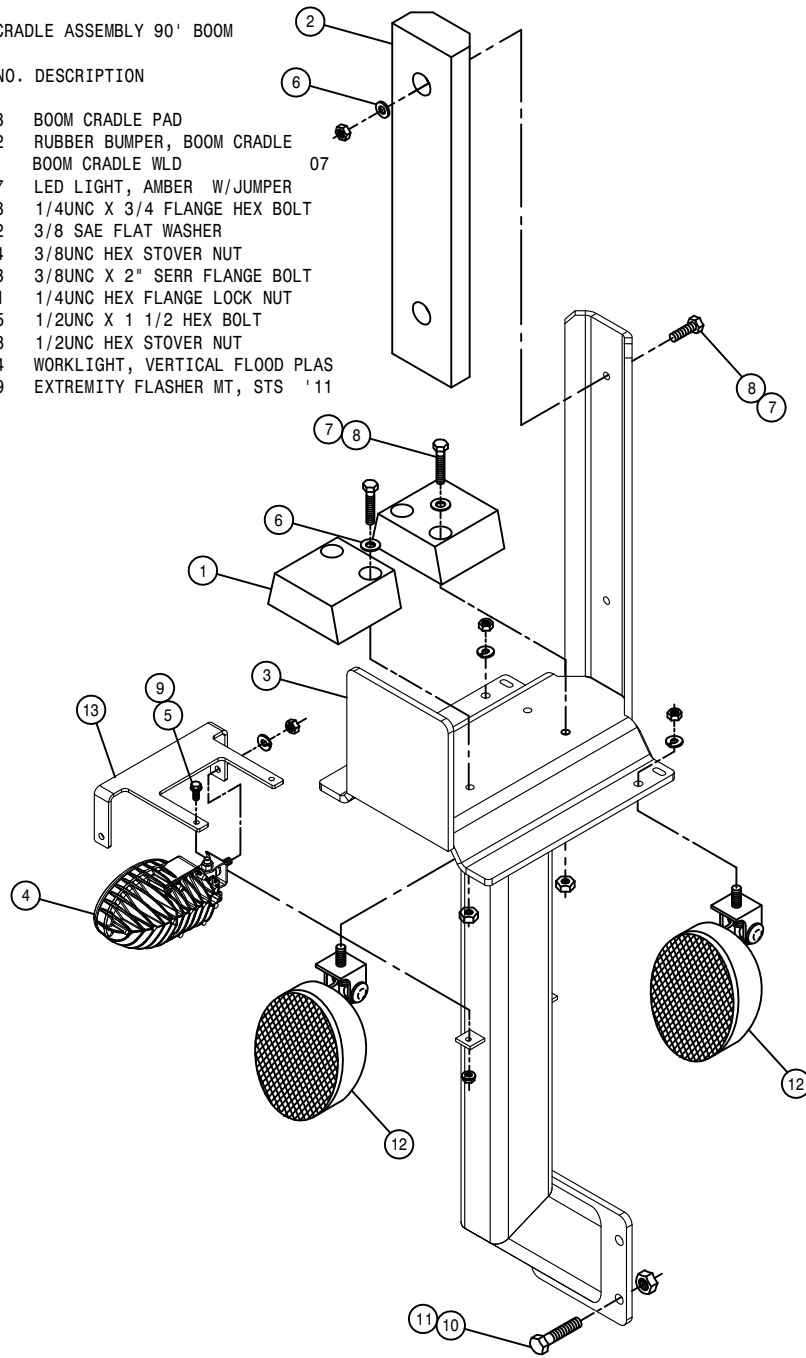

90' BOOM CRADLE

RH BOOM CRADLE ASSEMBLY 120' BOOM

DET.	QTY	PART NO.	DESCRIPTION
1	1	A53884	BUMPER, BOOM CRADLE, DELTA
2	1	164512	RUBBER BUMPER, BOOM CRADLE
3	1	A53874	MACHINE CRADLE WLD, DELTA
4	1	292917	LED LIGHT, AMBER W/JUMPER
5	2	470118	1/4UNC X 3/4 FLANGE HEX BOLT
6	1	920002	3/8 SAE FLAT WASHER
7	4	914004	3/8UNC HEX STOVER NUT
8	3	900133	3/8UNC X 2" SERR FLANGE BOLT
9	2	470121	1/4UNC HEX FLANGE LOCK NUT
10	4	900265	1/2UNC X 1 1/2 HEX BOLT
11	4	914008	1/2UNC HEX STOVER NUT
12	2	291904	WORKLIGHT, VERTICAL FLOOD PLAS
13	1	343689	EXTREMITY FLASHER MT, STS '11
14	2	470087	3/8UNC HEX FLANGE LOCK NUT
15	2	470328	3/8UNC X 1 1/4 #3HD PLOW BOLT
16	1	900142	3/8UNC X 5" HEX BOLT
17	1	A53915	WEAR PAD, BOOM CRADLE 120' BOOM

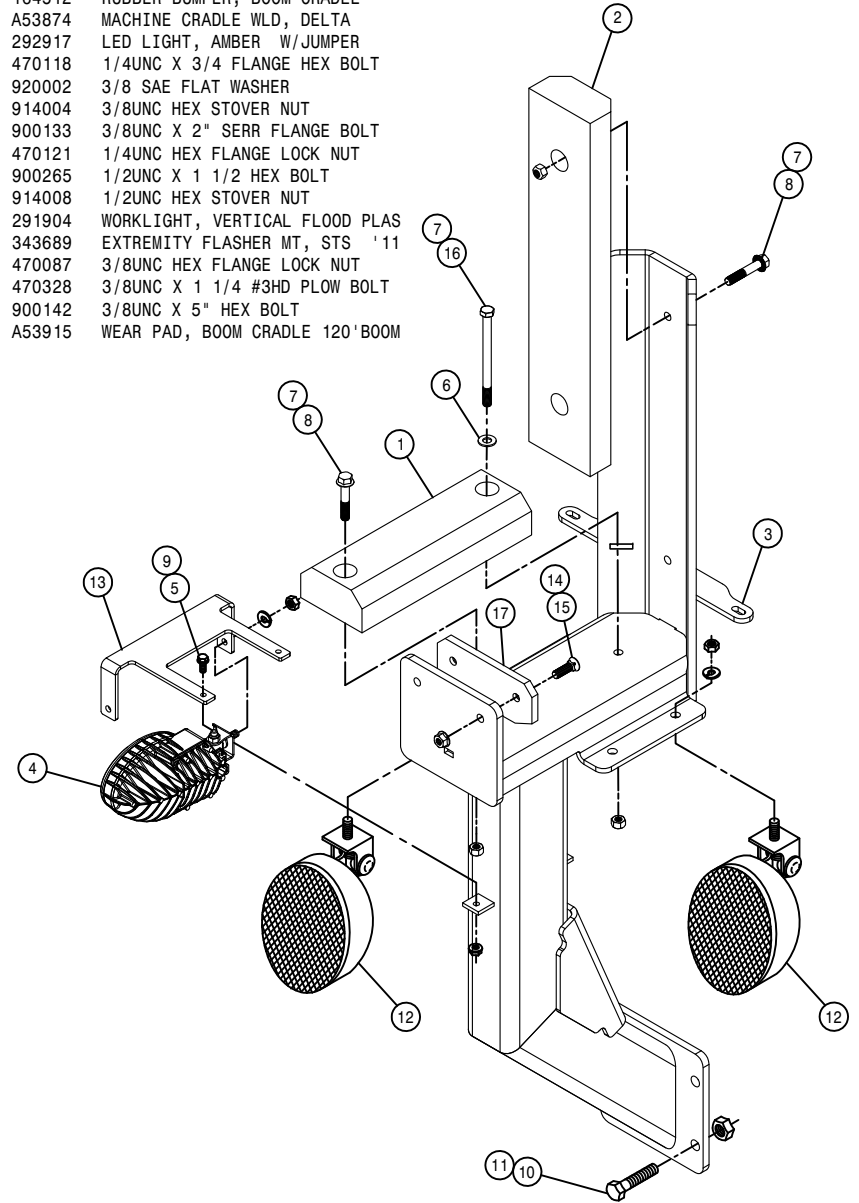

120' BOOM CRADLE

LH BOOM CRADLE ASSEMBLY 90' BOOM

DET.	QTY	PART NO.	DESCRIPTION
1	2	164513	BOOM CRADLE PAD
2	1	164512	RUBBER BUMPER, BOOM CRADLE
3	1	165041	BOOM CRADLE WLD
4	1	292917	LED LIGHT, AMBER W/JUMPER
5	2	470118	1/4UNC X 3/4 FLANGE HEX BOLT
6	6	920002	3/8 SAE FLAT WASHER
7	6	914004	3/8UNC HEX STOVER NUT
8	6	900133	3/8UNC X 2" SERR FLANGE BOLT
9	2	470121	1/4UNC HEX FLANGE LOCK NUT
10	4	900265	1/2UNC X 1 1/2 HEX BOLT
11	4	914008	1/2UNC HEX STOVER NUT
12	2	291904	WORKLIGHT, VERTICAL FLOOD PLAS
13	1	343689	EXTREMITY FLASHER MT, STS '11

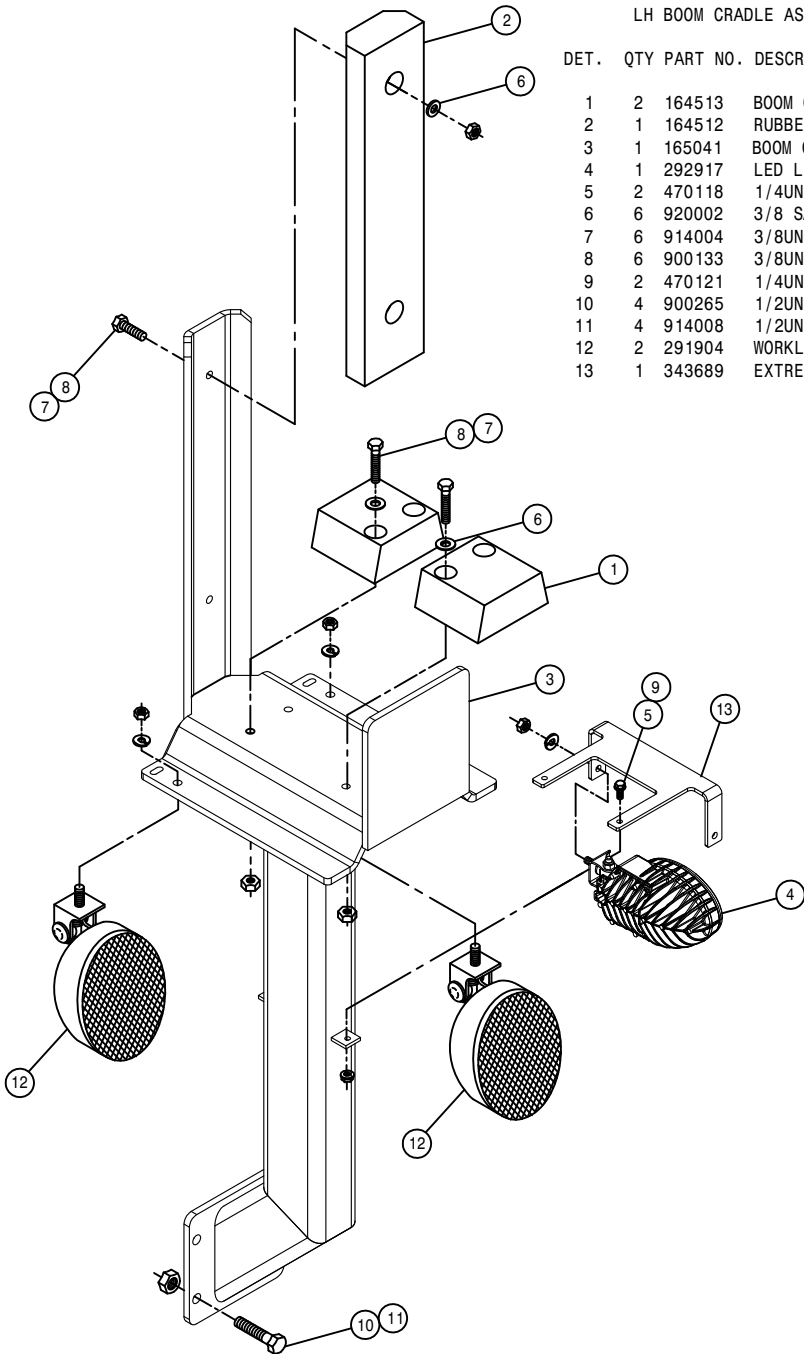

90' BOOM CRADLE

LH BOOM CRADLE ASSEMBLY 120' BOOM

DET.	QTY	PART NO.	DESCRIPTION
1	1	A53884	BUMPER, BOOM CRADLE, DELTA
2	1	164512	RUBBER BUMPER, BOOM CRADLE
3	1	A53874	MACHINE CRADLE WLD, DELTA
4	1	292917	LED LIGHT, AMBER W/JUMPER
5	2	470118	1/4UNC X 3/4 FLANGE HEX BOLT
6	1	920002	3/8 SAE FLAT WASHER
7	4	914004	3/8UNC HEX STOVER NUT
8	3	900133	3/8UNC X 2" SERR FLANGE BOLT
9	2	470121	1/4UNC HEX FLANGE LOCK NUT
10	4	900265	1/2UNC X 1 1/2 HEX BOLT
11	4	914008	1/2UNC HEX STOVER NUT
12	2	291904	WORKLIGHT, VERTICAL FLOOD PLAS
13	1	343689	EXTREMITY FLASHER MT, STS '11
14	2	470087	3/8UNC HEX FLANGE LOCK NUT
15	2	470328	3/8UNC X 1 1/4 #3HD PLOW BOLT
16	1	900142	3/8UNC X 5" HEX BOLT
17	1	A53915	WEAR PAD, BOOM CRADLE 120' BOOM

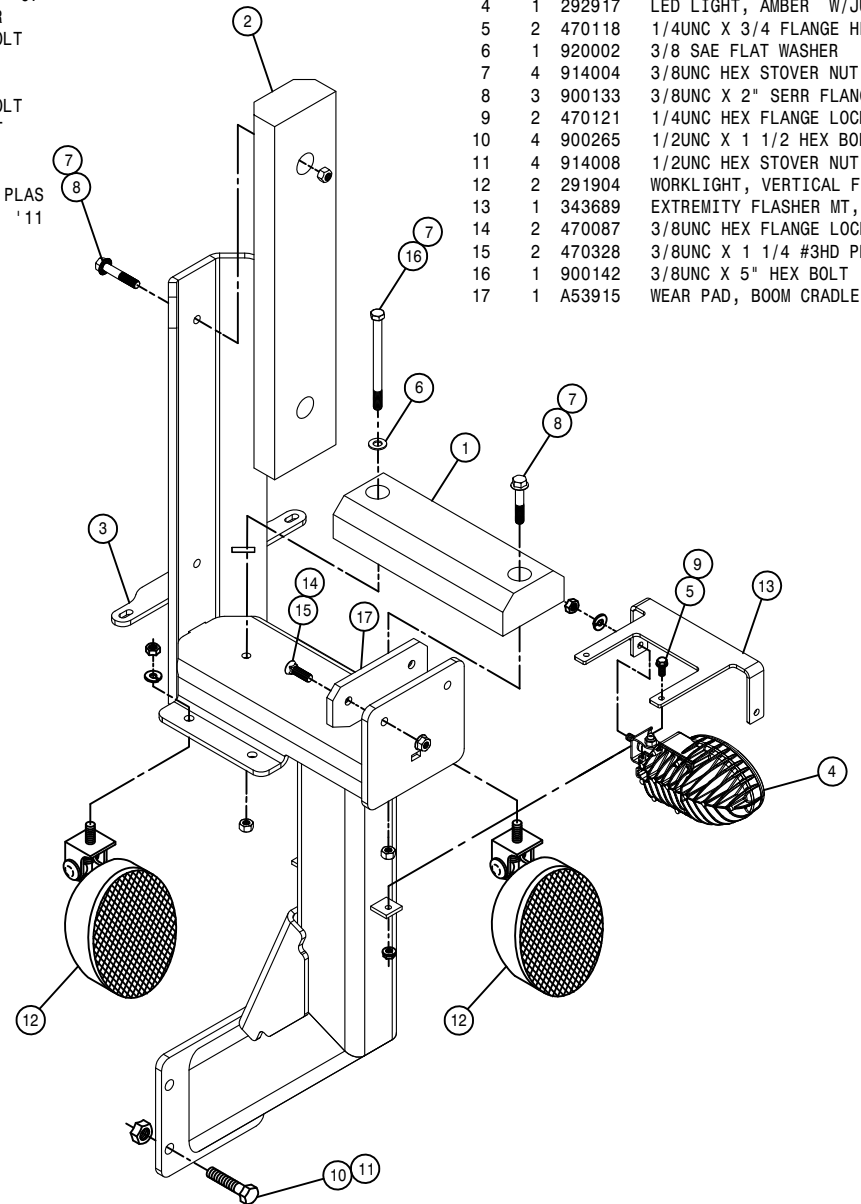

120' BOOM CRADLE

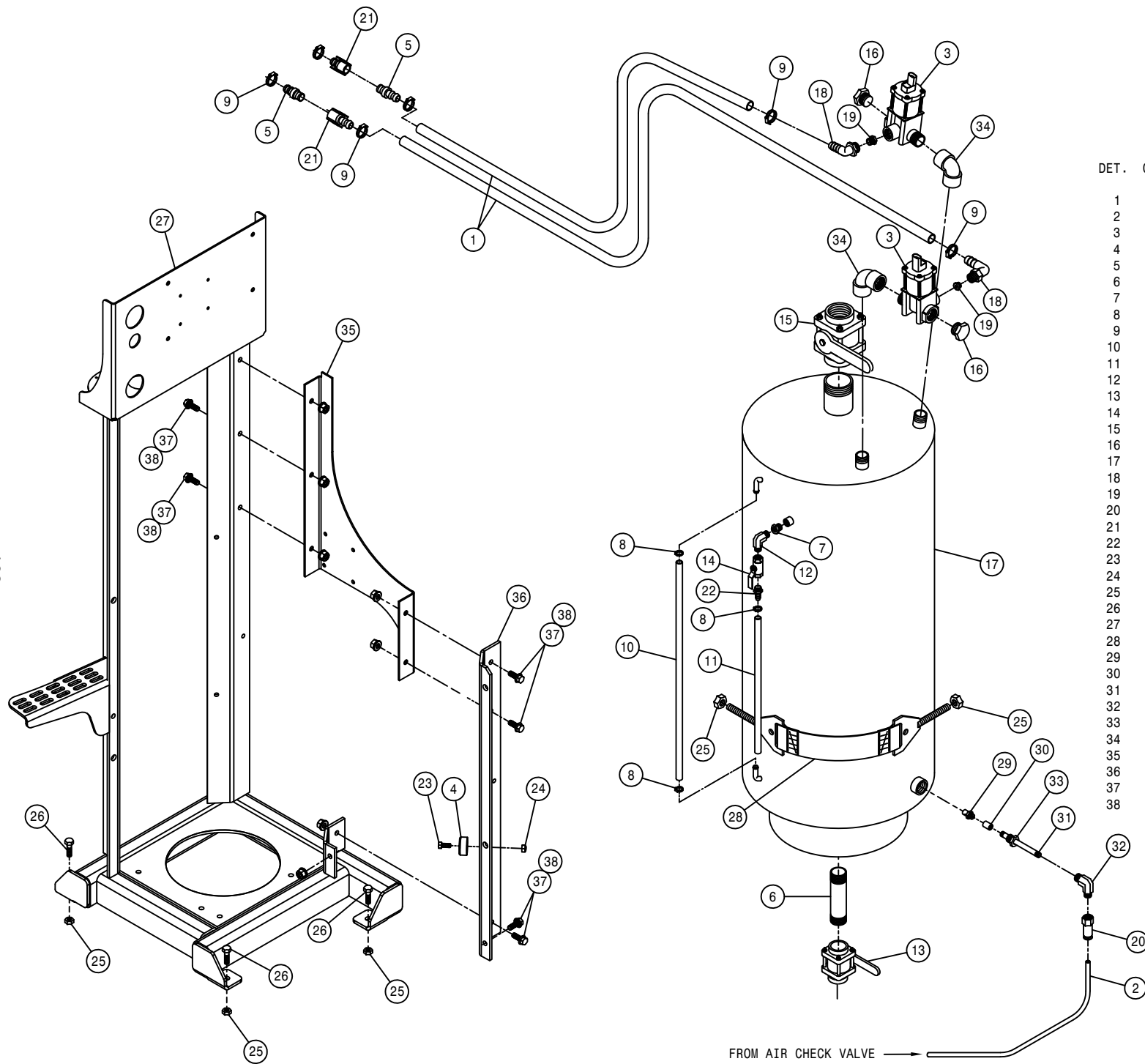

FOAMER TANK ASSEMBLY

DET.	QTY	PART NO.	DESCRIPTION
	1	2	195908 HOSE 3/4ID-1/8W CLEAR VINYL
	2	1	601624 HOSE, 3/8 X 60 AIR
	3	2	696181 3/4" ELECT SOLU SOLE VALVE 02
	4	6	470294 RUBBER BUMPER, RECESS, .63H-1.5D
	5	2	696208 .75 HOSE BARB-MALE COUPLER
	6	1	505205 BLK PIPE NIPPLE 1.00NPT-5.00
	7	1	505211 3/8-1/4NPT REDU BUSH, BRS
	8	3	520120 HOSE CLAMP NO 4 STAINLESS
	9	6	520055 HOSE CLAMP NO 12 STAINLESS
	10	1	601419 HOSE, 3/8 X 30 CLEAR VINYL
	11	1	601420 HOSE, 3/8 X 48 CLEAR VINYL
	12	1	618571 1/4MNPT-90-1/4MNPT LBO
	13	1	695900 BALL VALVE 1IN FNPT POLY
	14	1	696120 BALL VALVE, 1/4NPT, STEEL
	15	1	696134 BALL VALVE 2IN FNPT POLY
	16	2	500043 3/4NPT PIPE PLUG, POLY
	17	1	701112 FOAM MARKER TANK, 36 GAL SS
	18	2	701214 1/2NPT-90-3/4HBARB, 1/4TAP, POLY
	19	2	701215 1/4PIPE PLUG, .187 ORIFICE, POLY
	20	1	711051 1/4FNPT-3/8 NYL TUBE, SNGL
	21	2	696207 .75 HOSE BARB-FEMALE COUPLER
	22	1	783304 1/4 NPT X 3/8 HOSE BARB, BRS
	23	6	900064 5/16UNC X 3/4 HEX BOLT
	24	6	914002 5/16UNC HEX STOVER NUT
	25	7	914008 1/2UNC HEX STOVER NUT
	26	3	900264 1/2UNC X 1 1/4 HEX BOLT
	27	1	701257 FMR TANK MT WELD STS 07
	28	2	701170 FOAMER TANK STRAP ASSY
	29	1	701144 FOAMER AIR NOZZLE
	30	1	500223 SS PIPE CPLG, 1/8NPT
	31	1	507021 SS PIPE NIPPLE, 1/8NPT X 6"
	32	1	701143 FOAMER AIR TUBE FTG
	33	1	507728 REDU BUSH 1/2MNPT X 1/4FNPT, SS
	34	2	500079 3/4NPT-90 EL, POLY
	35	1	701269 LH FMR TANK SUPP CHAN, LG STS07
	36	1	701270 FMR TANK CROSS BRACE STS 07
	37	8	470460 3/8UNC X 1 SERR FLANGE BOLT
	38	8	470087 3/8UNC HEX FLANGE LOCK NUT

FROM AIR CHECK VALVE →

FRESH WATER TANK ASSEMBLY

DET. QTY PART NO. DESCRIPTION

1	1	470318	RINSE TANK, 3 GAL SQ W/LID
2	1	500019	3/4NPT-1/2HOSE BARB, POLY
3	1	500047	1/2NPT-90-1/2 HOSE BARB, POLY
4	2	520070	HOSE CLAMP NO 8 STAINLESS
5	1	601489	HOSE, 1/2 X 72 CLEAR VINYL
6	1	696082	BALL VALVE 1/2FNPT POLY
7	1	713340	1/2NPT-1/2 HOSE BARB, POLY
8	4	900064	5/16UNC X 3/4 HEX BOLT
9	2	903853	6-32X1 1/4 PHIL PN MACH SCR,SS
10	2	910022	6-32 HEX NUT
11	4	920501	5/16 LOCK WASHER
12	1	701257	FMR TANK MT WELD STS 07
13	2	920512	# 6 LOCK WASHER
14	1	470337	6" LID FOR 3 GAL TANK 470318
15	1	314901	FILTER MINDER AIR RESTRICT GA
16	1	701310	AIR PRESS GAUGE, 1/8"BOT
17	1	711019	1/4"MNPT AIR REGULATOR
18	1	711021	1 1/4-18 NUT,AIR REGULATOR MT
19	3	711043	1/4MNPT-90-3/8 NYL 1-TUBE LBO
20	1	601587	HOSE, 3/8 X 102 AIR
21	1	601624	HOSE, 3/8 X 60 AIR
22	1	601633	HOSE, 3/8 X 11 AIR
23	1	711051	1/4FNPT-3/8 NYL TUBE, SNGL
24	1	696235	1/4" ELECT SOLU SOLE VLV, 2203
25	1	711052	1/4"NPT CHECK VALVE,SWING,2600
26	1	618571	1/4MNPT-90-1/4MNPT LBO
27	1	195913	HOSE 7/64" WINDSHIELD WASHER

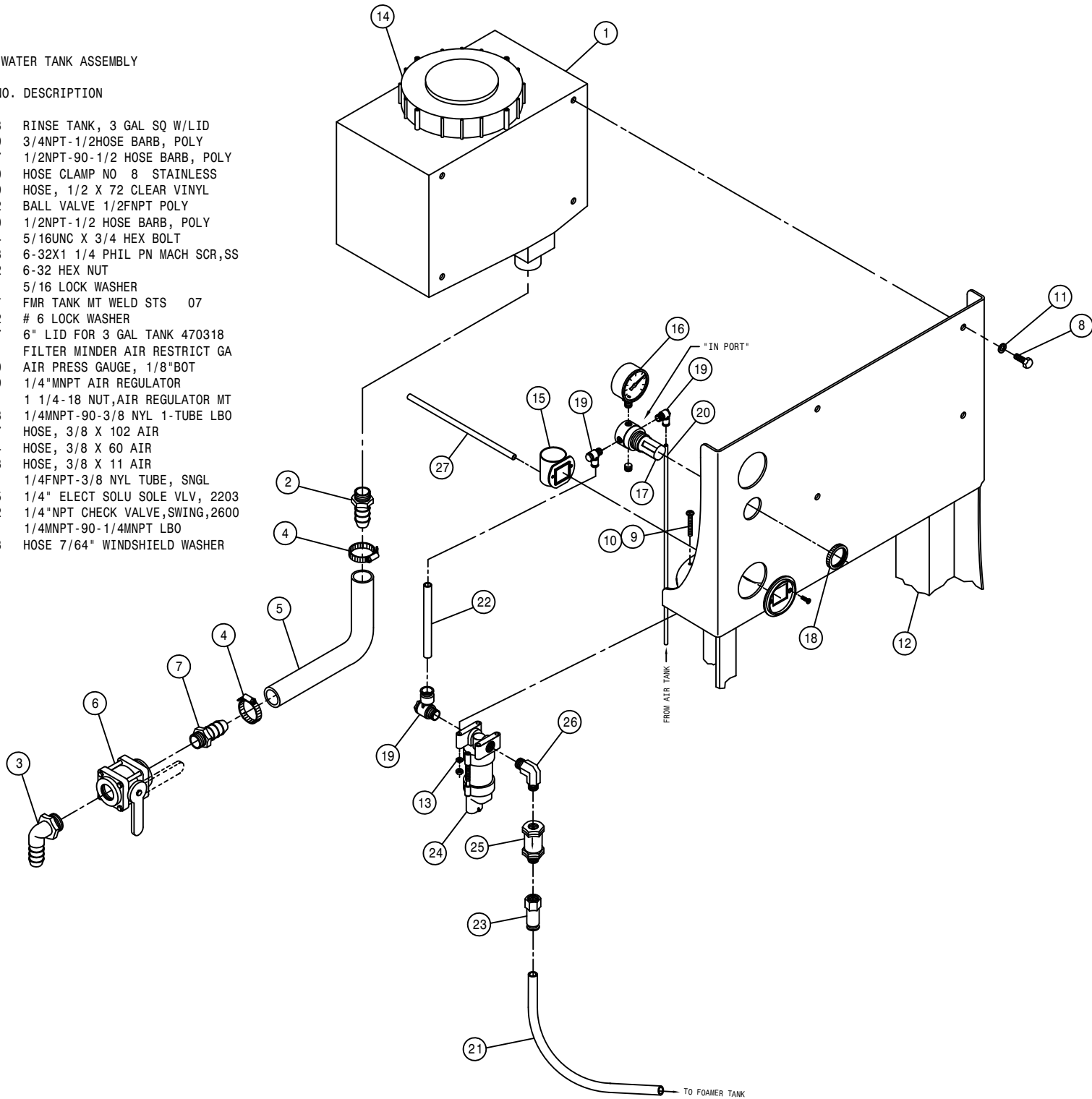

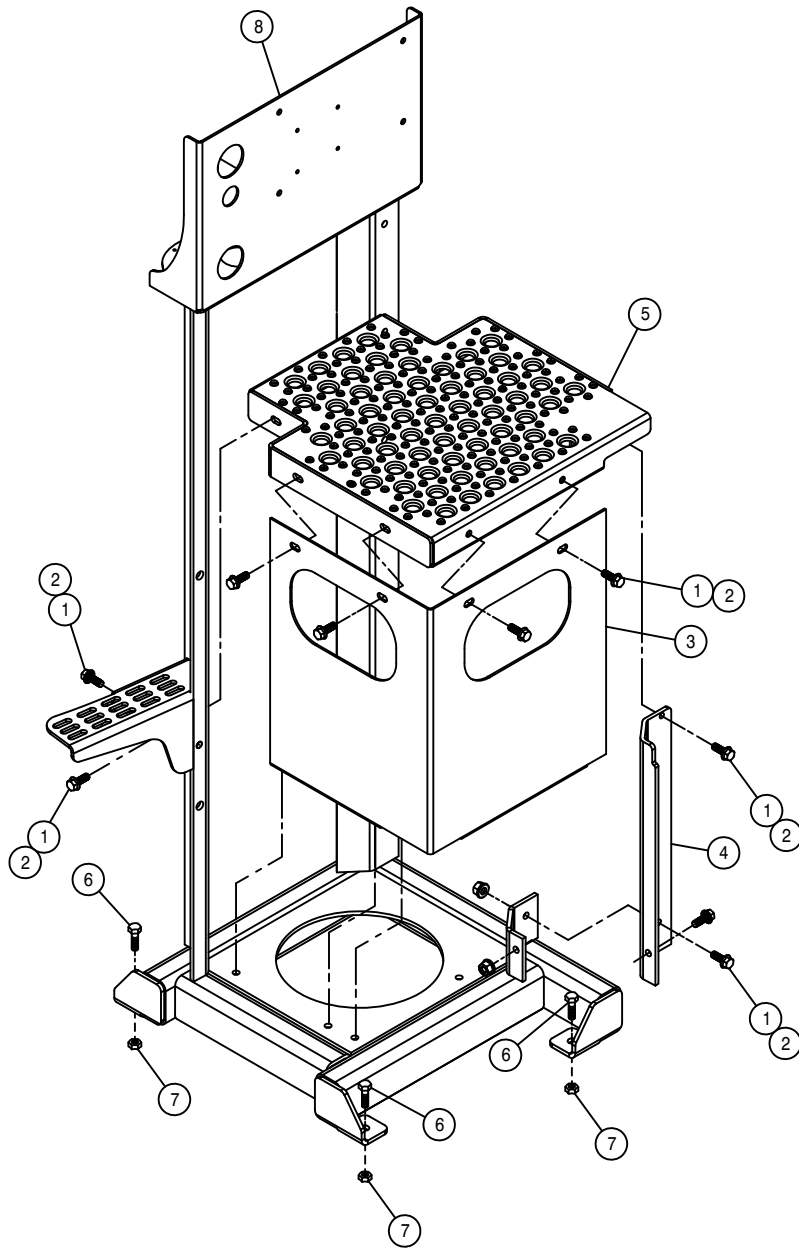

FRESH WATER TANK MT W/O FOAMER ASSEMBLY

DET. QTY PART NO. DESCRIPTION

1	12	470087	3/8UNC HEX FLANGE LOCK NUT
2	12	470460	3/8UNC X 1 SERR FLANGE BOLT
3	1	701268	FOAMER SERV PLTFRM WRAP
4	1	701263	LH FMR TANK SUPP CHAN STS 07
5	1	701264	FMR SERV PLATFRM WELD
6	3	900264	1/2UNC X 1 1/4 HEX BOLT
7	3	914008	1/2UNC HEX STOVER NUT
8	1	701257	FMR TANK MT WELD STS 07

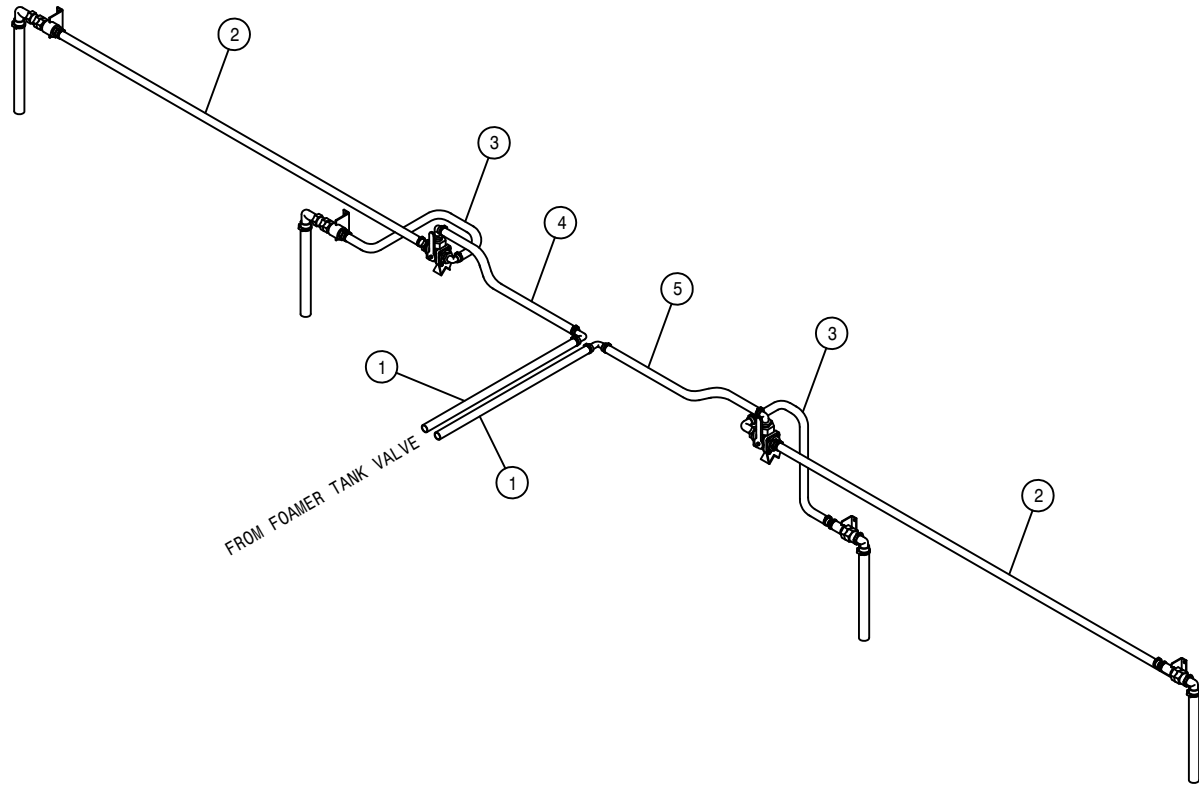

90° BOOM FOAMER HOISING

DET.	QTY	PART NO.	DESCRIPTION
1	2	195908	HOSE, 3/4ID-1/8W CLEAR VINYL X 206"
2	2	195908	HOSE, 3/4ID-1/8W CLEAR VINYL X 205"
3	2	195908	HOSE, 3/4ID-1/8W CLEAR VINYL X 24"
4	1	195908	HOSE, 3/4ID-1/8W CLEAR VINYL X 584"
5	1	195908	HOSE, 3/4ID-1/8W CLEAR VINYL X 420"

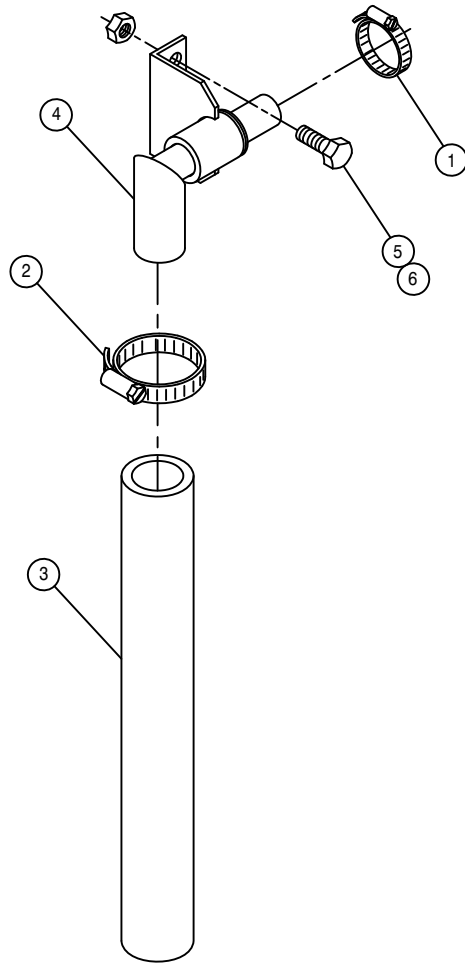

FOAMER DROP HOSE ASSEMBLY

DET.	QTY	PART NO.	DESCRIPTION
	1	520055	HOSE CLAMP NO 12 STAINLESS
	1	520085	HOSE CLAMP NO 24 STAINLESS
	1	601367	HOSE, 1 1/4 X 24 2BR BLK EPDM
	1	701194	FOAMER DROP HOSE SWIVEL WLD
	2	900129	3/8UNC X 1" HEX BOLT
	2	914004	3/8UNC HEX STOVER NUT

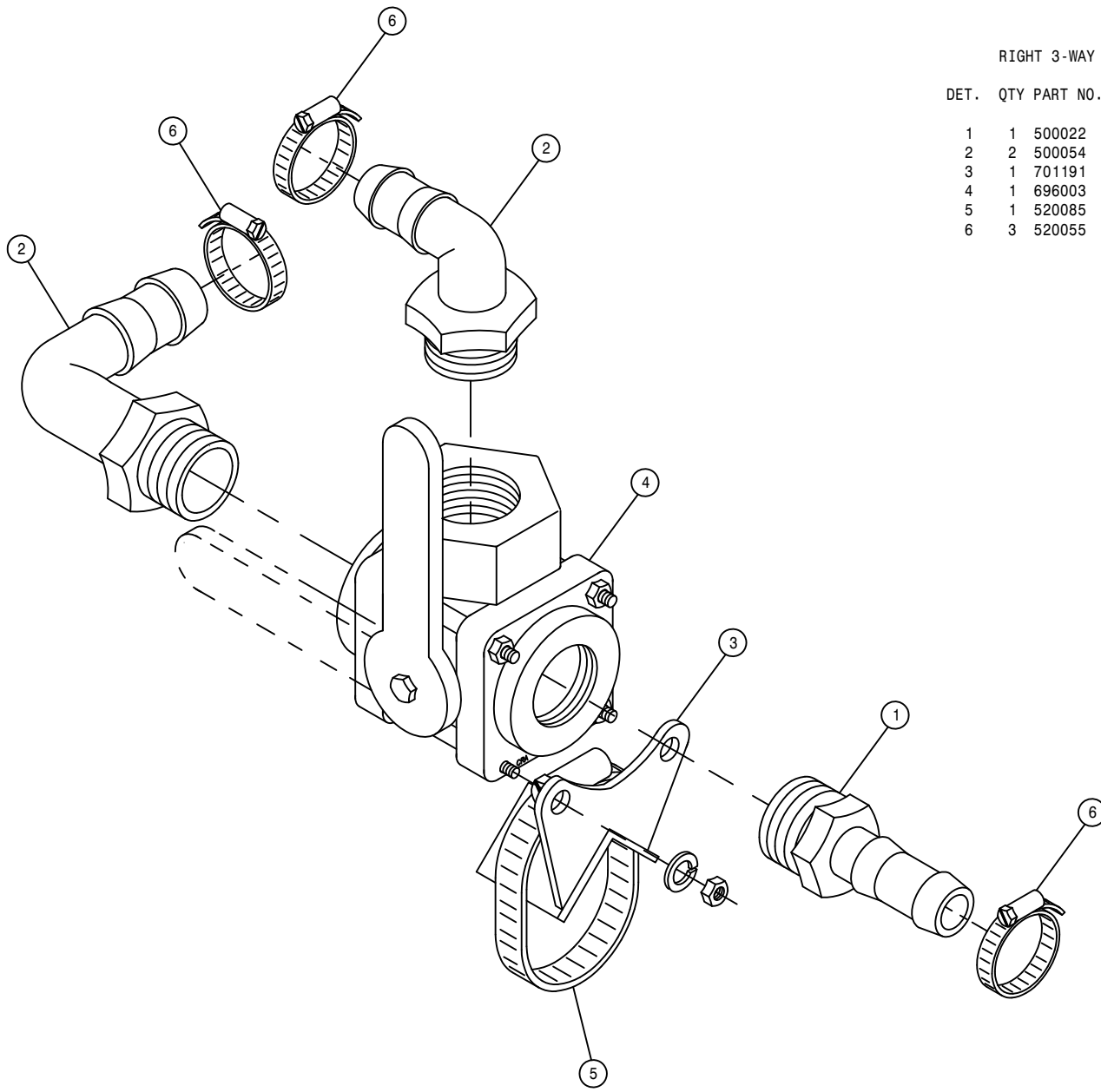

RIGHT 3-WAY FOAMER VALVE ASSEMBLY

DET. QTY PART NO. DESCRIPTION

1	1	500022	3/4NPT-3/4HOSE BARB, POLY
2	2	500054	3/4NPT-90-3/4 HOSE BARB, POLY
3	1	701191	1" SOLU VLV MT WLD
4	1	696003	BALL VLV,3/4NPT 3WAY-SIDE POLY
5	1	520085	HOSE CLAMP NO 24 STAINLESS
6	3	520055	HOSE CLAMP NO 12 STAINLESS

LEFT 3-WAY FOAMER VALVE ASSEMBLY

DET. QTY PART NO. DESCRIPTION

1	1	500022	3/4NPT-3/4HOSE BARB, POLY
2	2	500054	3/4NPT-90-3/4 HOSE BARB, POLY
3	1	701191	1" SOLU VLV MT WLD
4	1	696003	BALL VLV,3/4NPT 3WAY-SIDE POLY
5	1	520085	HOSE CLAMP NO 24 STAINLESS
6	3	520055	HOSE CLAMP NO 12 STAINLESS

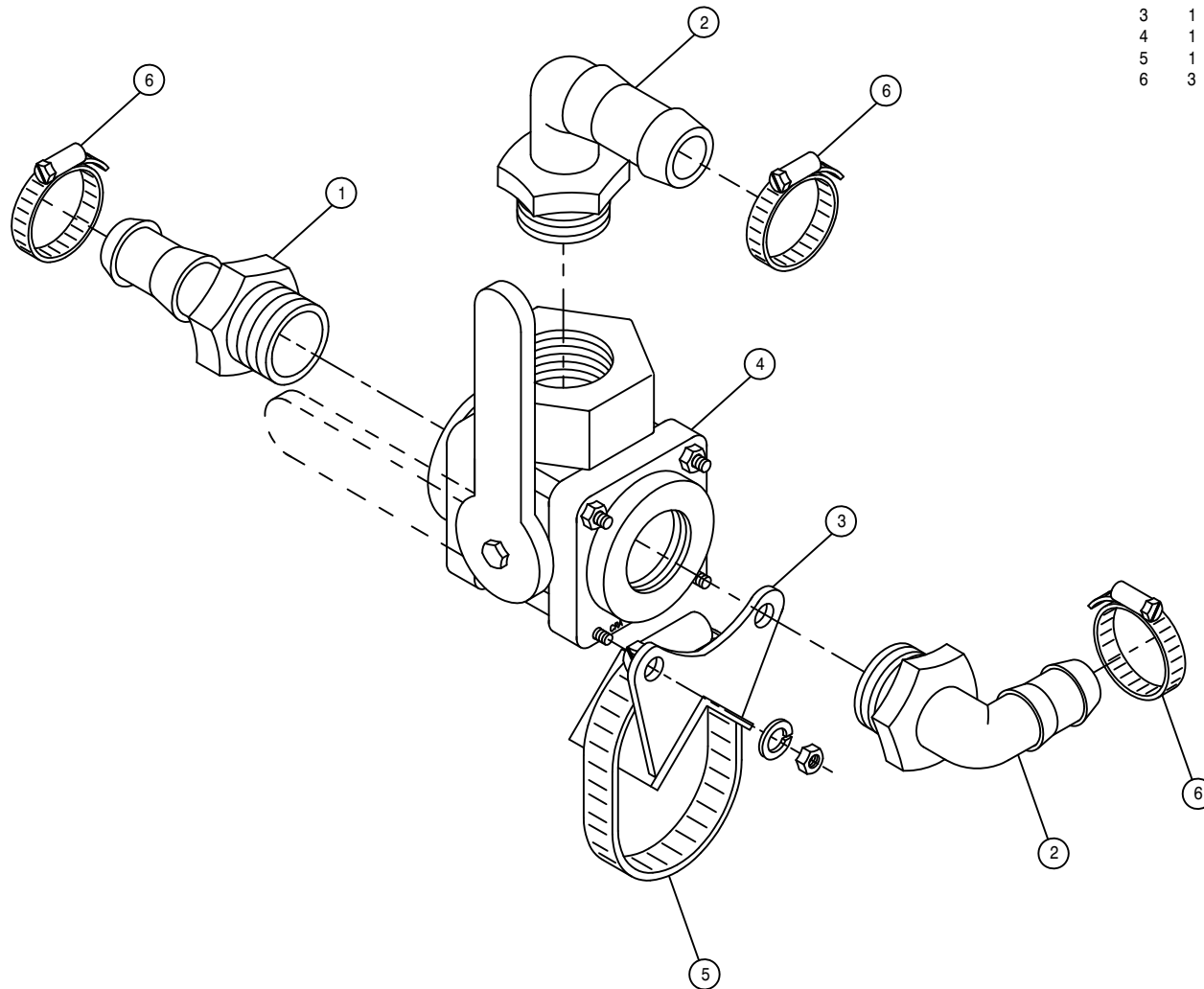

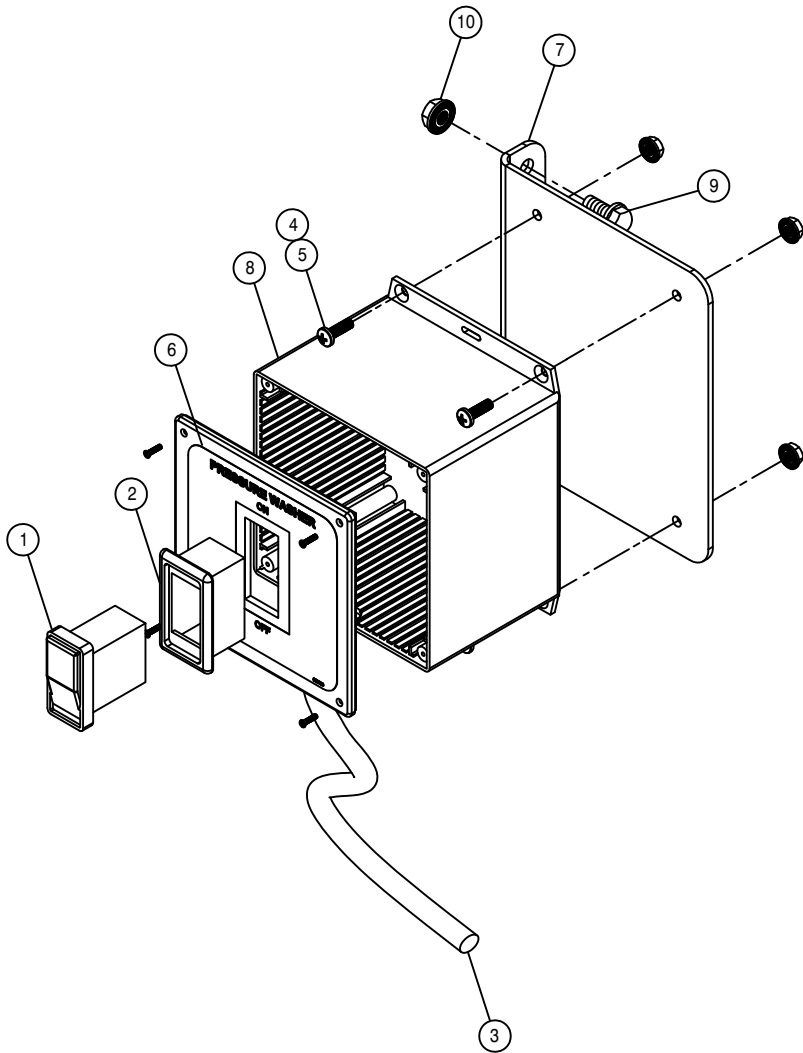

PRESSURE WASHER SWITCH BOX ASSEMBLY

DET. QTY PART NO. DESCRIPTION

1	1	292218	SWITCH,SIDE FILL PUMP/PRESWASH
2	1	292260	MOUNTING TRIM, SINGLE VMS
3	1	293878	PRESS WASH WIRE HARNESS STS 07
4	4	470175	10-32 HEX FLANGE LOCK NUT
5	4	903710	10-32X5/8 PHIL PANHD MACH SCR
6	1	650156	DECAL,PRESS WASH CTRL STS 05
7	1	691112	PRESS WASH SWITCH BX MT,STS 09
8	1	690975	PRESS WASH SWITCH BOX, STS 05
9	2	900064	5/16UNC X 3/4 HEX BOLT
10	2	470113	5/16UNC HEX FLANGE LOCK NUT

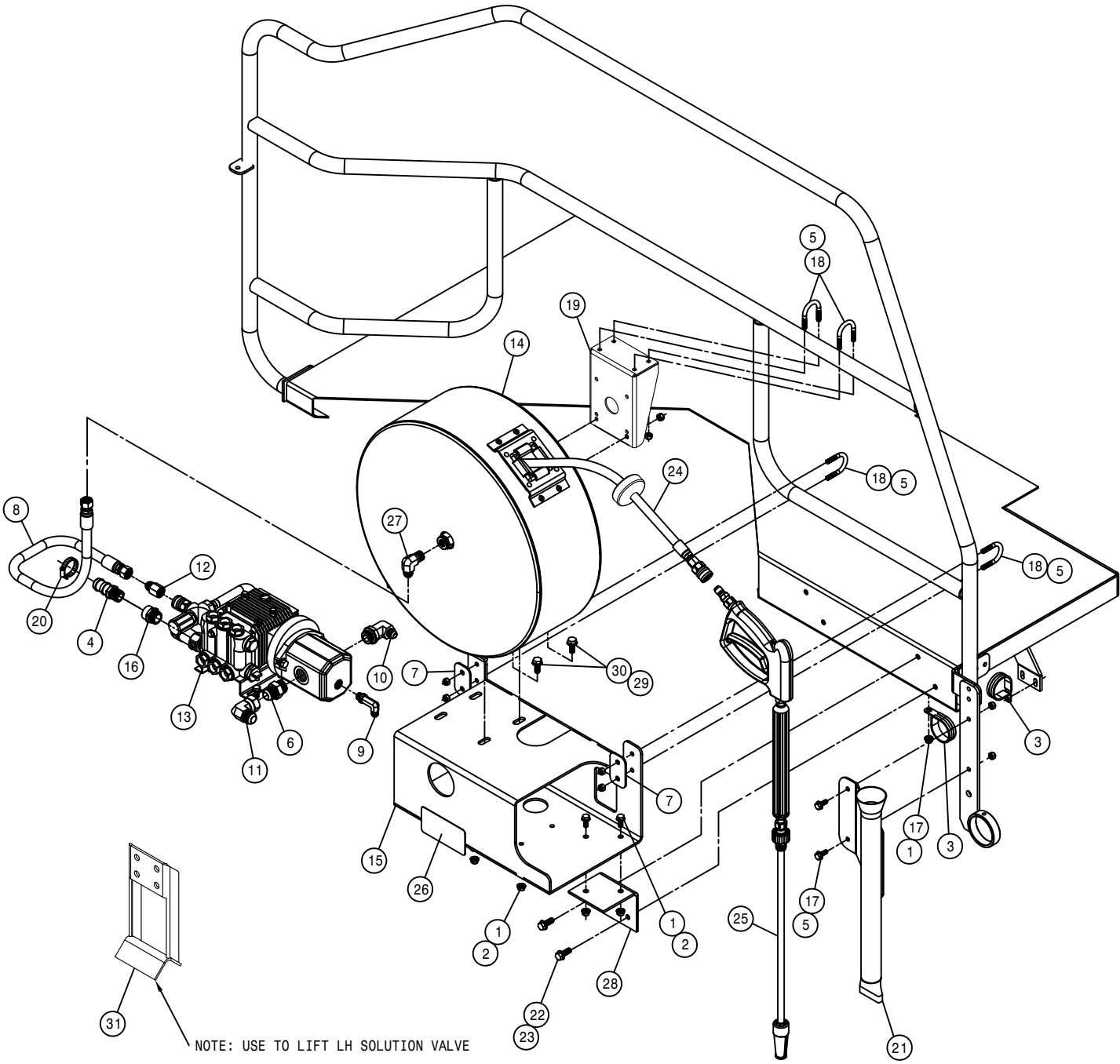

PRESSURE WASHER OPTION

DET.	QTY	PART NO.	DESCRIPTION
1	9	470113	5/16UNC HEX FLANGE LOCK NUT
2	8	470233	5/16UNC X 3/4 FLANGE HEX BOLT
3	2	520126	CUSH CLAMP,#32 2IN X 5/8W
4	1	500123	3/4NPT-1"HOSE BARB, POLY
5	10	473001	5/16UNC HEX NUT,NYLOC 316 SS
6	1	611127	1 1/16MJIC-1 1/16MOR ADPTR
7	2	691119	PRESS WASHER SUPP PLT, STS 09
8	1	616459	08-451TC-08FJX-08FJX-26 H/A
9	1	618440	9/16MJIC-90-9/16MOR EX LG LBO
10	1	618474	3/4MJIC-90-1 1/16MOR LBO
11	1	618191	1 1/16MJ-90-1 1/16FJ SWIV LBO
12	1	618787	3/4MJIC-3/8FNPT ADPTR
13	1	690672	HMC 320 SPECIAL/MINUS HOSE
14	1	690931	HOSE REEL, ENCLOSED PRESS WASH
15	1	691114	PRESSURE WASHER MT WLD, STS 09
16	1	715449	3/4FNPT X 3/4MGT ADPTR BR
17	3	900064	5/16UNC X 3/4 HEX BOLT
18	4	473911	5/16UNC-1.31ID-2.00 U-BOLT
19	1	691118	PRESS WASH REEL SUPP WLD, STS09
20	1	520090	HOSE CLAMP NO 16 STAINLESS
21	1	691120	PRESSURE WASHER WAND MT WLD 09
22	4	900129	3/8UNC X 1" SERR FLANGE BOLT
23	4	472029	3/8UNC HEX FLANGE NUT SERR SS
24	1	690941	REEL HOSE, 3/8" ID X 50' 3000PSI
25	1	690673	TRIGGER GUN ASSY FOR 690672
26	1	650217	DECAL, CAUTION,CHECK OIL LEVEL
27	1	618184	3/4MJIC-90-3/8MNPT LBO
28	2	691117	PRESSURE WASHER MT ANGL, STS 09
29	4	470325	7/16UNC HEX FLANGE LOCK NUT
30	4	900195	7/16UNC X 1" HEX BOLT
31	1	691092	80/90 BOOM VLV MT WLD, WASH09

NOTE: USE TO LIFT LH SOLUTION VALVE

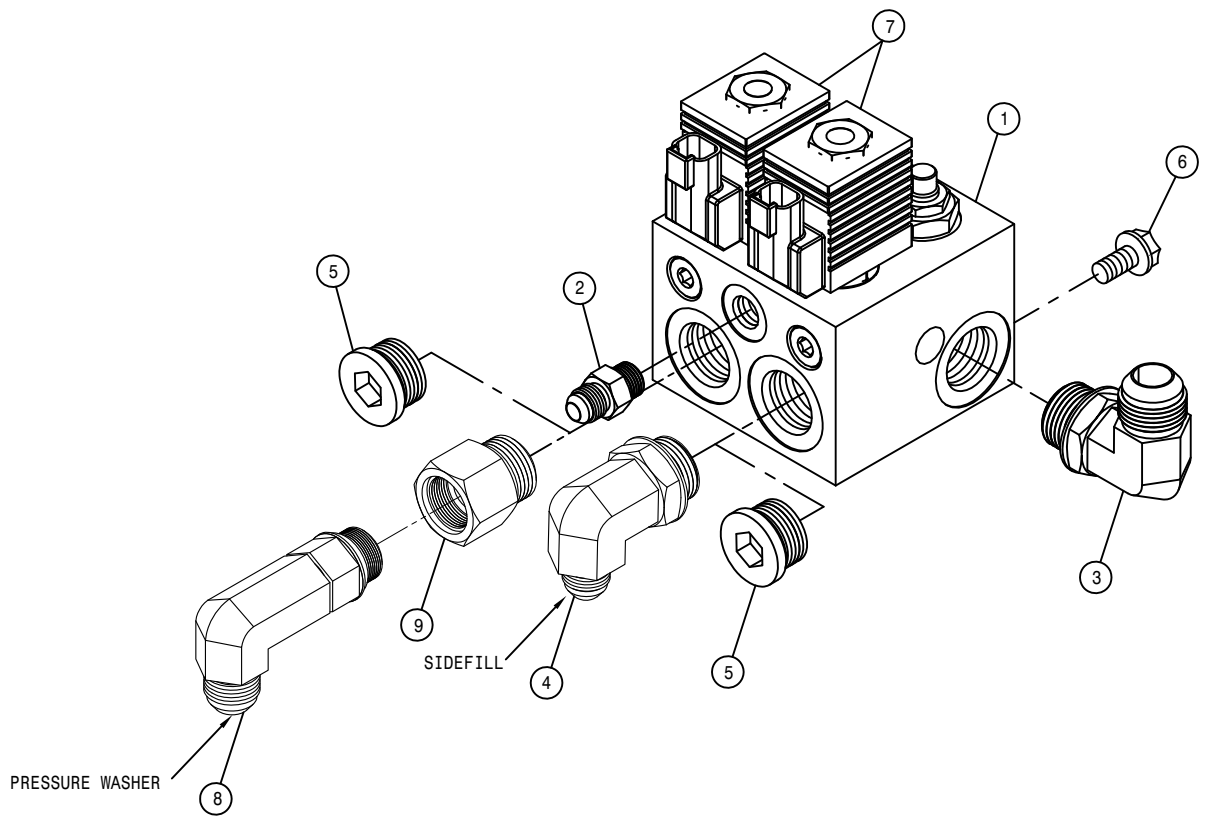

SIDEFILL/PRESSURE WASHER VALVE ASSEMBLY

DET.	QTY	PART NO.	DESCRIPTION	
	1	606259	DIVERSION VLV,STS LS	07
	1	618126	9/16MJIC-9/16MOR ADPTR	
	1	618248	1 1/16MJIC-90-1 1/16MOR LBO	
	1	618474	3/4MJIC-90-1 1/16MOR LBO	
	2	618757	1 1/16MOR PLUG, HEX SOCKET	
	2	900064	5/16UNC X 3/4 HEX BOLT	
	2	606309	COIL FOR VLV 606259	
	1	618774	7/8MJIC-90-7/8MOR LG LBO	
	1	618312	1 5/16MOR-1 1/16FOR ADPTR	

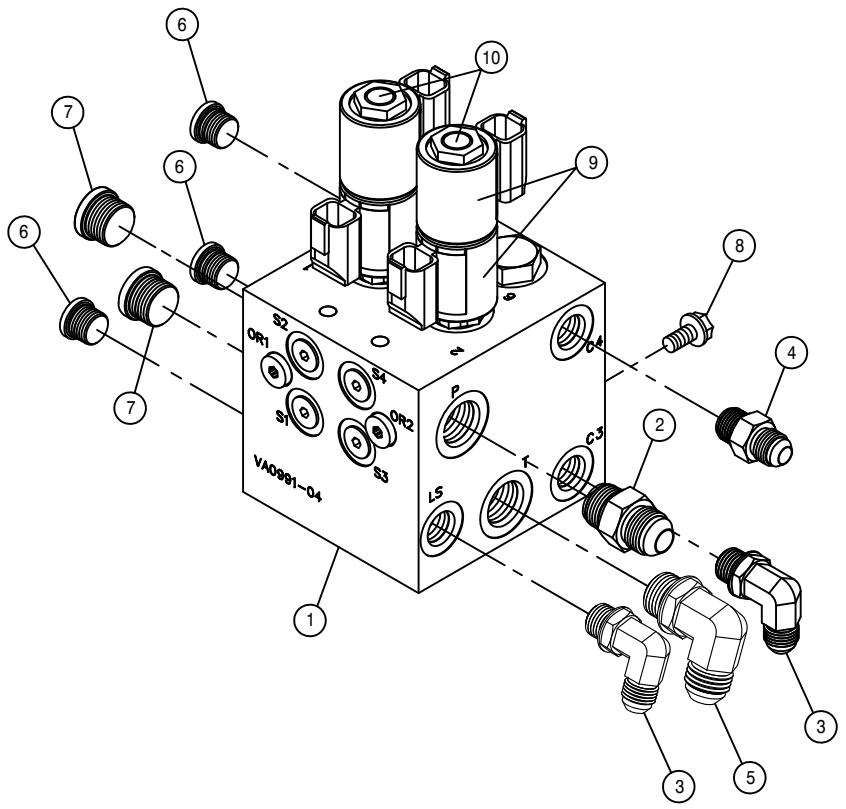

SIDEFILL LIFT VALVE ASSEMBLY

DET.	QTY	PART NO.	DESCRIPTION	PWRSYS
1	1	606249	MANIFOLD,TRD ADJ	PWRSYS
2	1	611125	3/4MJIC-3/4MOR ADPTR	
3	2	618119	9/16MJIC-90-9/16MOR LBO	
4	1	618126	9/16MJIC-9/16MOR ADPTR	
5	1	618241	3/4MJIC-90-3/4MOR LBO	
6	3	618754	9/16MOR PLUG, HEX SOCKET	
7	2	618755	3/4MOR PLUG, HEX SOCKET	
8	2	900064	5/16UNC X 3/4 HEX BOLT	
9	4	606266	#8 COIL W/DEUTSCH	
10	2	606358	CARTRIDGE SP08-47D,PROP,3POS	

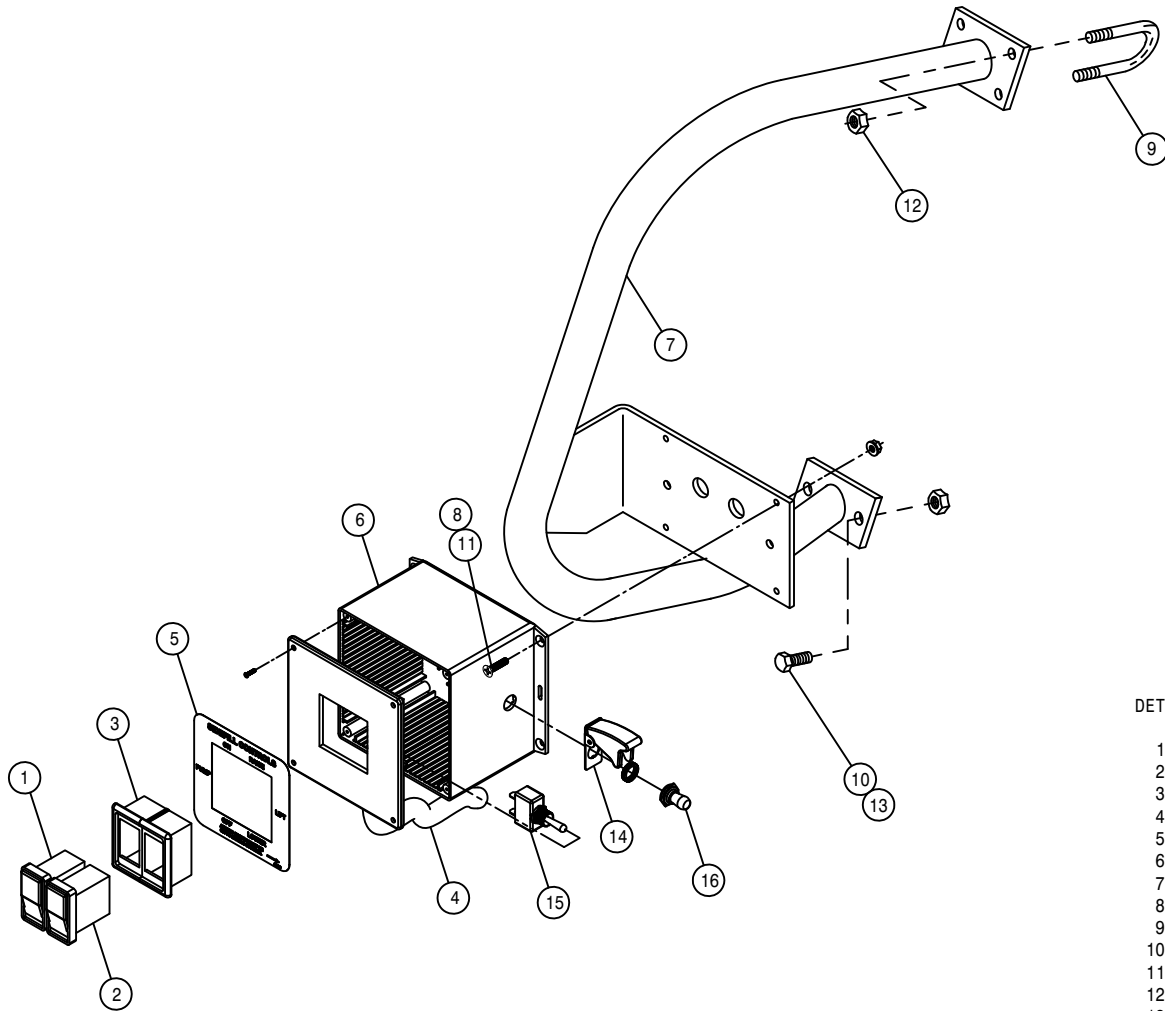

SIDE FILL SWITCH BOX ASSEMBLY

DET. QTY PART NO. DESCRIPTION

DET.	QTY	PART NO.	DESCRIPTION
1	1	292218	SWITCH,SIDE FILL PUMP/PRESWASH
2	1	292219	SWITCH, SIDE FILL LIFT, STS
3	2	292261	MOUNTING TRIM,END VME
4	1	293578	SIDE FILL WIRE HARNESS LS 07
5	1	650155	DECAL,SIDEFILL CTRL STS 05
6	1	691057	SIDE FILL SWITCH BOX, STS 07
7	1	690723	CHEM IND GUARD WLD
8	4	470175	10-32 HEX FLANGE LOCK NUT
9	2	473911	5/16UNC-1.31ID-2.00 U-BOLT
10	2	900130	3/8UNC X 1 1/4 SER FLANGE BOLT
11	4	903723	10-32 x 3/4 PHIL FLHD MACH SCR
12	4	914002	5/16UNC HEX STOVER NUT
13	2	914004	3/8UNC HEX STOVER NUT
14	1	291655	AIRCRAFT TOGGLE SWITCH GUARD
15	1	291937	TOGGLE SWITCH, SPST
16	1	470001	RUBBER BOOT W NUT FOR 298012

SIDE/CHEMICAL INDUCTOR ASSEMBLY

DET.	QTY	PART NO.	DESCRIPTION
1	1	121101	TRANSOM PIVOT BRG, TOP POLYGON
2	1	470352	LANYARD, 11" POLY
3	2	500024	1"NPT-90-1"HOSE BARB, POLY
4	1	500041	3/4NPT-90-1/2"HOSE BARB, POLY
5	1	500085	1" X 3/4NPT REDU NIPPLE, POLY
6	8	500157	1" FLANGE GASKET EPDM
7	8	500159	1" FLANGE CLAMP, S.S.
8	2	500163	1" FLANGE-1" MNPT ADPTR POLY
9	2	500164	3" FLANGE-3" MNPT ADPTR POLY
10	1	500168	1" FLANGE-1" FNPT ADPTR POLY
11	2	500173	1" FLANGE-90-1" HOSE BARB POLY
12	2	500174	1" FLANGE-90-1" FLANGE LBOPOLY
13	7	500208	3" FLANGE CLAMP, S.S.
14	7	500209	3" FLANGE GASKET EPDM
15	1	500210	3" FLANGE-3" HOSE BARB POLY
16	2	500213	3"FLANGE-90-3"FLANGE LBO POLY
17	1	500216	3"FLANGE PLUG W/1"FNPT POLY
18	1	500217	3" FLANGE TEE POLY
19	1	500220	3"FLANGE-3"MNPT W/1"FNPT POLY
20	1	505214	1" -3/4"NPT REDU BUSH, POLY
21	5	520090	HOSE CLAMP NO 16 STAINLESS
22	1	601609	HOSE, 1 X 33 1BR BLK EPDM
23	1	601611	HOSE, 1 X 30 2F-1W EPDM
24	1	618602	3/4MJIC-45-7/8MOR LBO
25	1	690488	1.00 CHECK VLV, SPRING LOADED
26	1	690760	BANJO PUMP, 3" SIDE FILL STS12
27	1	690916	SIDE FILL ARM WLD, STS 2004
28	3	696147	BALL VLV, 1" FLANGE
29	1	696149	BALL VLV, 3" FLANGE
30	1	696225	3.00FNPT-MALE COUPLER POLY
31	1	696231	CAP FOR 3.00 MALE COUPLER POLY
32	1	701085	TANK, 5 GAL, SQ WHITE
33	6	900064	5/16UNC X 3/4 HEX BOLT
34	4	900066	5/16UNC X 1 1/4 HEX BOLT
35	6	914002	5/16UNC HEX STOVER NUT
36	8	920001	5/16 SAE FLAT WASHER
37	4	920501	5/16 LOCK WASHER
38	1	473978	ROLL PIN, 1/2 X 3 1/2 LG
39	1	520070	HOSE CLAMP NO 8 STAINLESS
40	1	520145	3.56/3.88 T-BOLT HOSE CLAMP SS
41	1	601391	HOSE, 1 X 274 1BR BLK EPDM
42	1	621554	LADR/SF/BRKWAY CYL, 1.50 X12.25
43	1	690717	CHEM IND CYL MT WLD
44	1	690729	3.50 OD X 2.68 ID X 11 GA WASH
45	4	900265	1/2UNC X 1 1/2 HEX BOLT
46	2	900267	1/2UNC X 2" HEX BOLT
47	6	914008	1/2UNC HEX STOVER NUT
48	1	701155	8" LID FOR 5 GAL TANK 701085
49	1	500171	1" FLANGE-1" HOSE BARB POLY
50	2	618119	9/16MJIC-90-9/16MOR LBO
51	1	618733	9/16JIC .042 ORIFICE ADPTR
52	1	621555	REPAIR KIT, HYD CYL 621554
53	1	342991	SIDEFILL HOSE SUPP BRKT, STS 05
54	1	193012	QUICKEDGE TRIM .135 TO .250
55	1	611128	7/8MJIC-90-7/8MOR LBO
56	1	690762	SEAL ASSY, 3" BANJO PUMP 690760
57	1	690779	SOLU PUMP REPAIR KIT - 690760

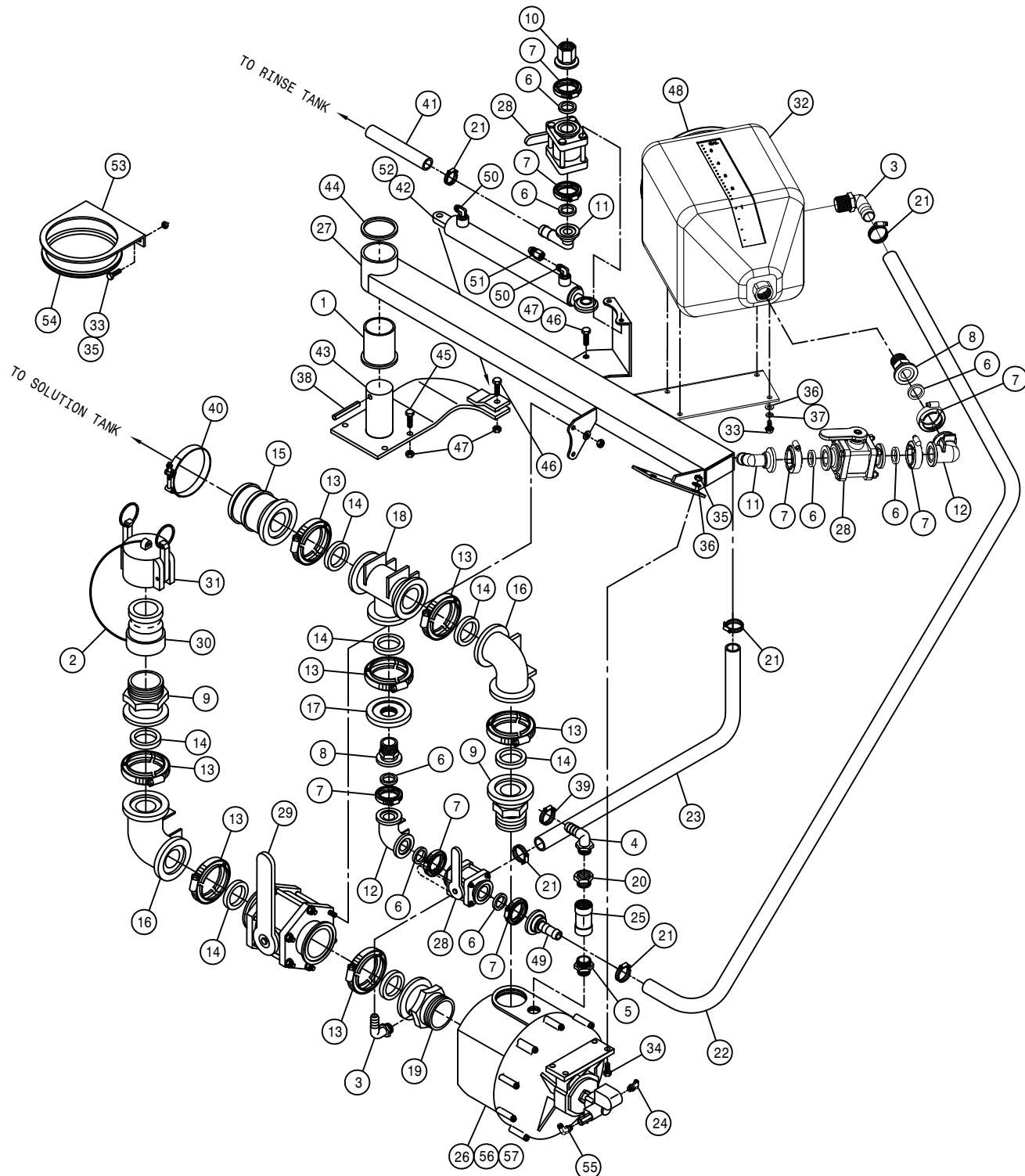

FRONT FILL ASSEMBLY

DET. QTY PART NO. DESCRIPTION

DET.	QTY	PART NO.	DESCRIPTION
1	1	470352	LANYARD, 11" POLY
2	1	500013	1"NPT HEX PIPE NIPPLE, POLY
3	1	500014	1"NPT-90 ST EL, POLY
4	1	500019	3/4NPT-1/2HOSE BARB, POLY
5	1	500063	1"NPT PIPE PLUG, POLY
6	2	500157	1" FLANGE GASKET EPDM
7	2	500159	1" FLANGE CLAMP, S.S.
8	1	500164	3" FLANGE-3" MNPT ADPTR POLY
9	1	500168	1" FLANGE-1" FNPT ADPTR POLY
10	1	500171	1" FLANGE-1" HOSE BARB POLY
11	4	500208	3" FLANGE CLAMP, S.S.
12	4	500209	3" FLANGE GASKET EPDM
13	1	500210	3" FLANGE-3" HOSE BARB POLY
14	1	500216	3"FLANGE PLUG W/1"FNPT POLY
15	1	500217	3" FLANGE TEE POLY
16	1	505214	1"-3/4"NPT REDU BUSH, POLY
17	1	690488	1.00 CHECK VLV, SPRING LOADED
18	1	691143	FRT FILL SUPP ARM WLD '10
19	1	696147	BALL VLV, 1" FLANGE
20	1	696149	BALL VLV, 3" FLANGE
21	1	696225	3.00FNPT-MALE COUPLER POLY
22	1	696231	CAP FOR 3.00 MALE COUPLER POLY
23	1	470253	HYD DAMPER,100LB,4"STROKE 1084
24	2	470254	BALL SOCKET, M6 THD X 10MM
25	2	470255	BALL STUD,5/16-18 THD X 10MM
26	2	470256	SAFTY CLIP, 10MM BALL SOCKET
27	1	472316	ROLL PIN, 5/16 X 1 1/2
28	1	482017	SPRING
29	1	520090	HOSE CLAMP NO 16 STAINLESS
30	1	520070	HOSE CLAMP NO 8 STAINLESS
31	1	520145	3.56/3.88 T-BOLT HOSE CLAMP SS
32	1	601725	HOSE, 1 X 225 1BR BLK EPDM
33	1	690698	FRT FILL SUPP ARM REL WLD
34	1	691139	FRT FILL SUPP ARM LATCH PIN'10
35	1	785007	KNOB,1 3/16" BALL,RED,3/8-16
36	3	900066	5/16UNC X 1 1/4 HEX BOLT
37	1	900418	3/4UNC X 7" HEX BOLT
38	2	910002	5/16UNC HEX NUT
39	1	914002	5/16UNC HEX STOVER NUT
40	2	473006	3/4UNC HEX JAM NUT, NYLOC
41	2	920006	3/4 SAE FLAT WASHER
42	2	920501	5/16 LOCK WASHER
43	1	601680	HOSE, 3 X 91 POLY HELIX EPDM
44	1	601676	HOSE, 1/2 X 270 1BR BLK EPDM
45	1	691140	FRT FILL LATCH BRKT WLD,STS'10
46	2	470113	5/16UNC HEX FLANGE LOCK NUT

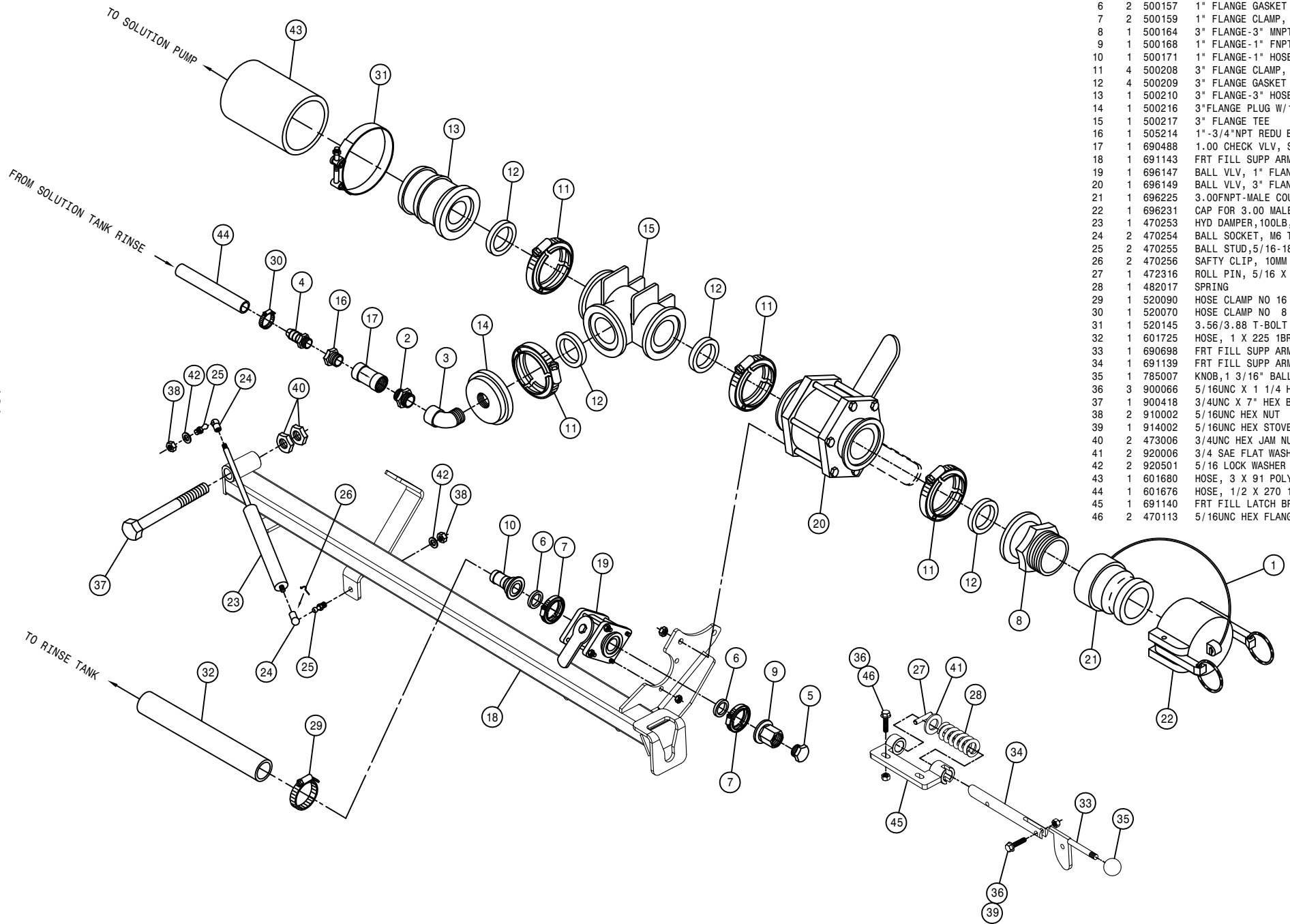

121

508121

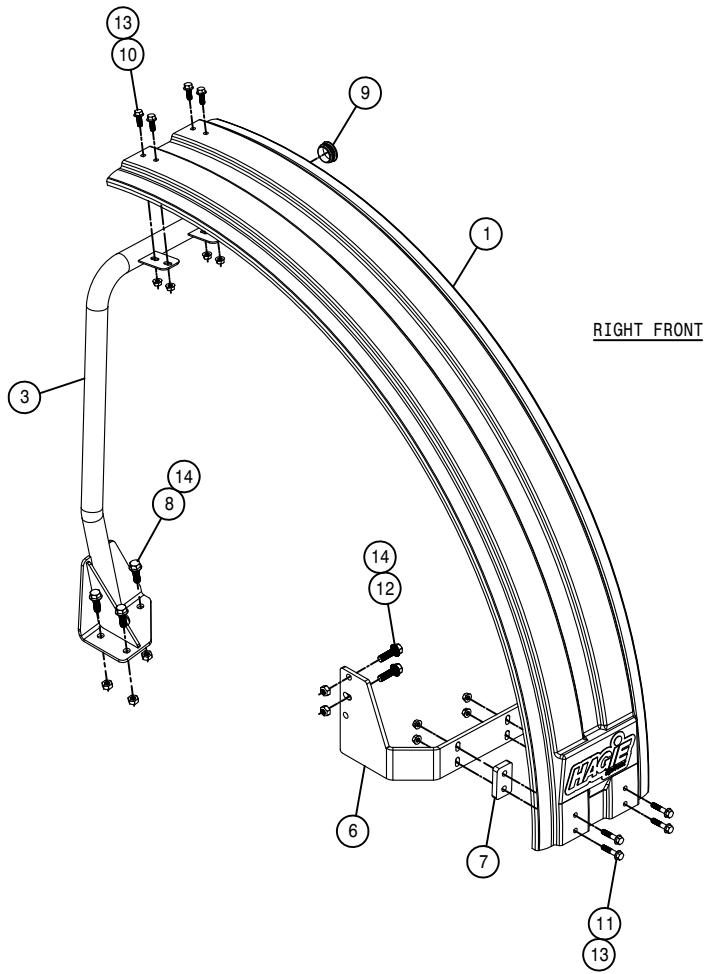

RIGHT FENDER ASSEMBLY

DET. QTY PART NO. DESCRIPTION

DET.	QTY	PART NO.	DESCRIPTION	
1	1	359598	FRONT FENDER, STS	'10
2	1	359599	REAR FENDER, STS	'10
3	1	359600	RH FRT FENDER BRKT WLD, STS	'10
4	1	359607	RH REAR FENDER BRKT WLD, STS	'10
5	1	359614	RH REAR UPR FENDER SUPP WLD	'10
6	2	359620	RH LWR FENDER SUPP, STS 54"	'10
7	4	359622	LWR FENDER SUPP SPACER, 54"	'10
8	6	470431	1/2UNC X 1 1/2 FLANGE BOLT	
9	3	629772	CAPPLUGS PLUG, 1 3/4"RD, BLK POLY	
10	12	900129	3/8UNC X 1" SERR FLANGE BOLT	
11	8	900132	3/8UNC X 1 3/4 SER FLANGE BOLT	
12	6	900266	1/2UNC X 1 3/4 HEX BOLT	
13	20	910004N	3/8UNC FLANGE CNTR LOCK NUT	
14	12	914008	1/2UNC HEX STOVER NUT	

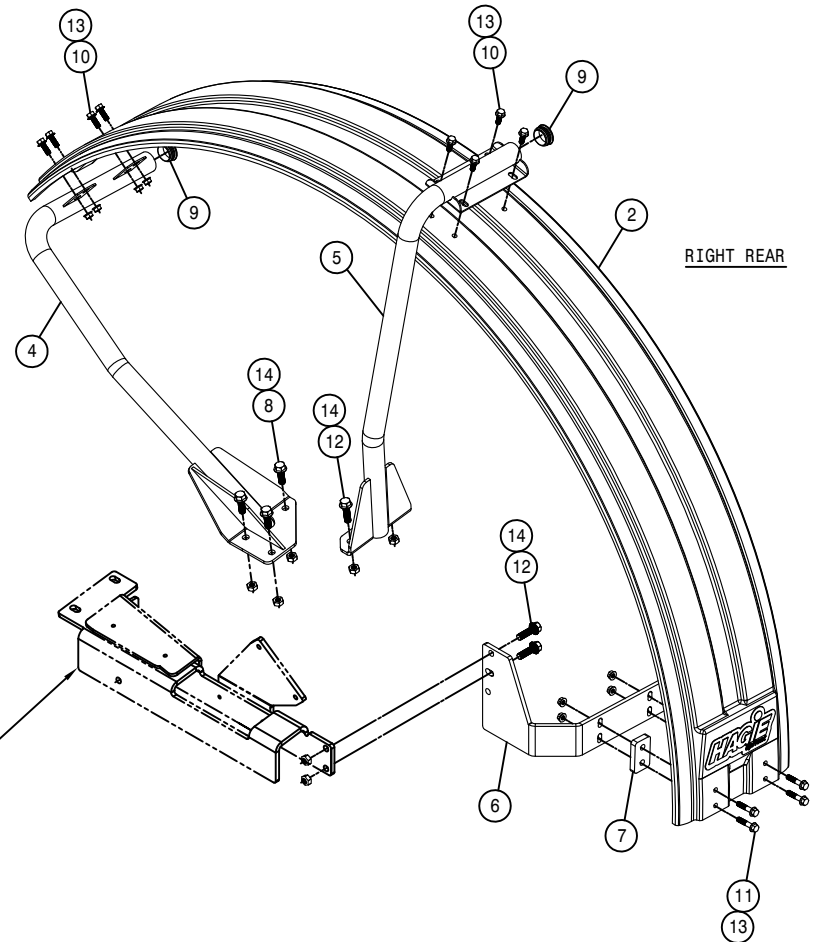

NOTE: 359624 SHOWN FOR REFERENCE
SEE LEG ASSEMBLY

LEFT FENDER ASSEMBLY

DET. QTY PART NO. DESCRIPTION

1	1	359598	FRONT FENDER, STS	'10
2	1	359599	REAR FENDER, STS	'10
3	1	359601	LH FRT FENDER BRKT WLD, STS	'10
4	1	359608	LH REAR FENDER BRKT WLD, STS	'10
5	1	359615	LH REAR UPR FENDER SUPP WLD	'10
6	1	359621	LH LWR FENDER SUPP, STS 54"	'10
7	4	359622	LWR FENDER SUPP SPACER, 54"	'10
8	6	470431	1/2UNC X 1 1/2 FLANGE BOLT	
9	3	629772	CAPPLUGS PLUG, 1 3/4"RD, BLK POLY	
10	12	900129	3/8UNC X 1" SERR FLANGE BOLT	
11	8	900132	3/8UNC X 1 3/4 SER FLANGE BOLT	
12	6	900266	1/2UNC X 1 3/4 HEX BOLT	
13	20	910004N	3/8UNC FLANGE CNTR LOCK NUT	
14	12	914008	1/2UNC HEX STOVER NUT	

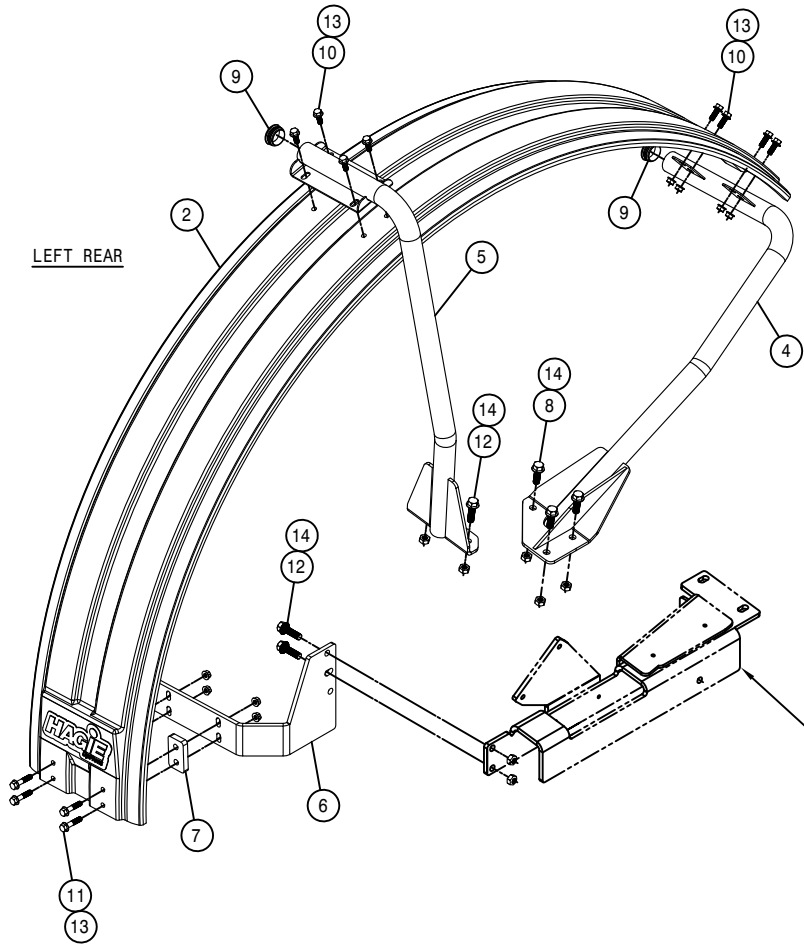

LEFT REAR

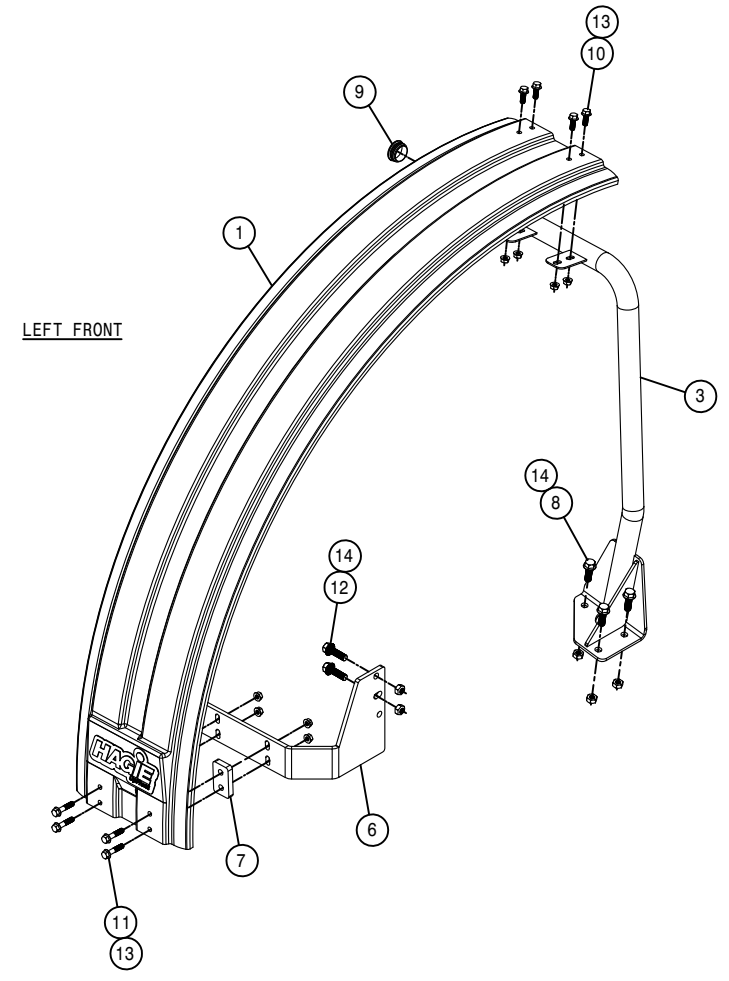

LEFT FRONT

NOTE: 359625 SHOWN FOR REFERENCE
SEE LEG ASSEMBLY

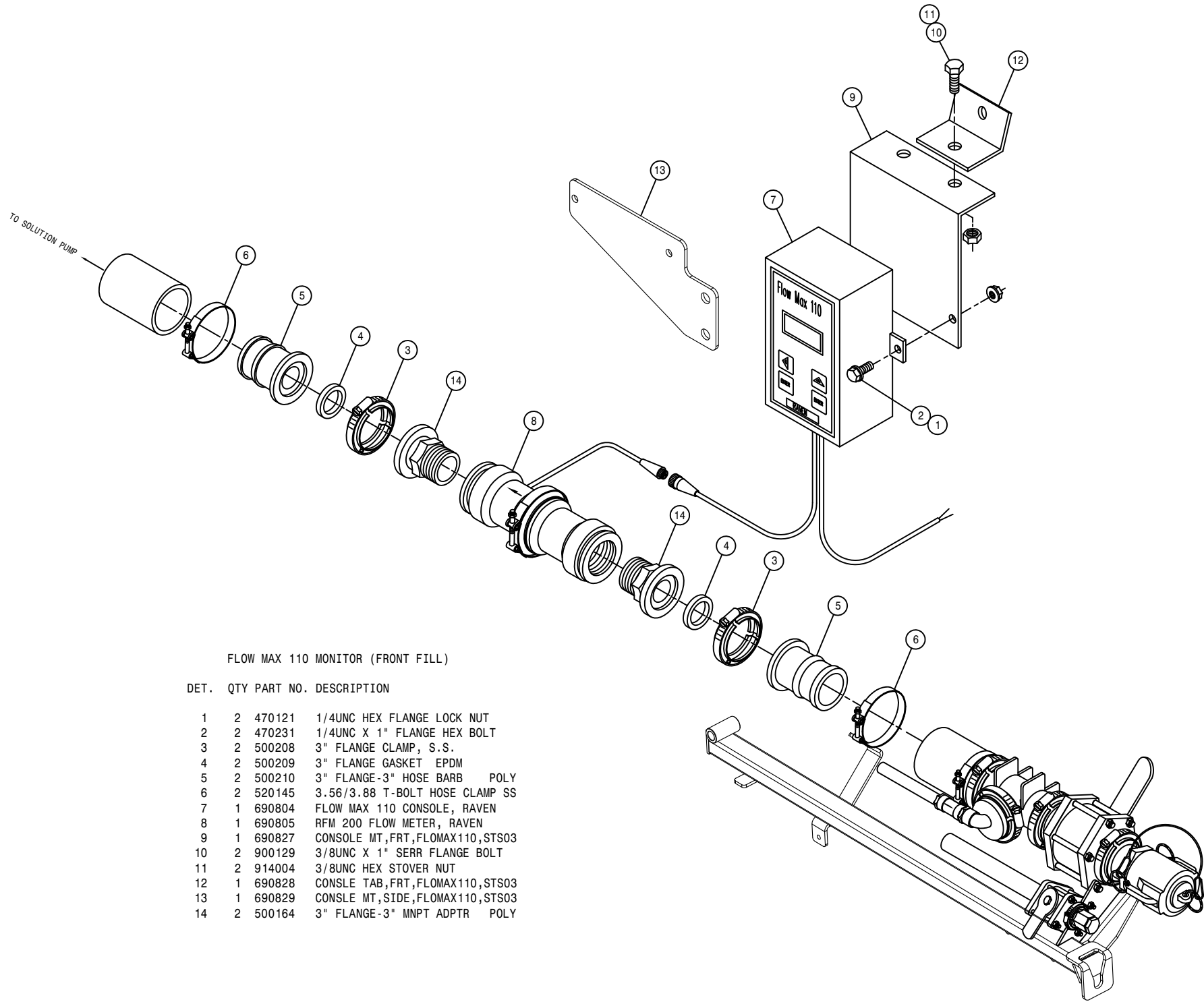

FLOW MAX 110 MONITOR (FRONT FILL)

DET.	QTY	PART NO.	DESCRIPTION
	1	2 470121	1/4UNC HEX FLANGE LOCK NUT
	2	2 470231	1/4UNC X 1" FLANGE HEX BOLT
	3	2 500208	3" FLANGE CLAMP, S.S.
	4	2 500209	3" FLANGE GASKET EPDM
	5	2 500210	3" FLANGE-3" HOSE BARB POLY
	6	2 520145	3.56/3.88 T-BOLT HOSE CLAMP SS
	7	1 690804	FLOW MAX 110 CONSOLE, RAVEN
	8	1 690805	RFM 200 FLOW METER, RAVEN
	9	1 690827	CONSOLE MT,FRT,FLOMAX110,STS03
	10	2 900129	3/8UNC X 1" SERR FLANGE BOLT
	11	2 914004	3/8UNC HEX STOVER NUT
	12	1 690828	CONSLE TAB,FRT,FLOMAX110,STS03
	13	1 690829	CONSLE MT,SIDE,FLOMAX110,STS03
	14	2 500164	3" FLANGE-3" MNPT ADPTR POLY

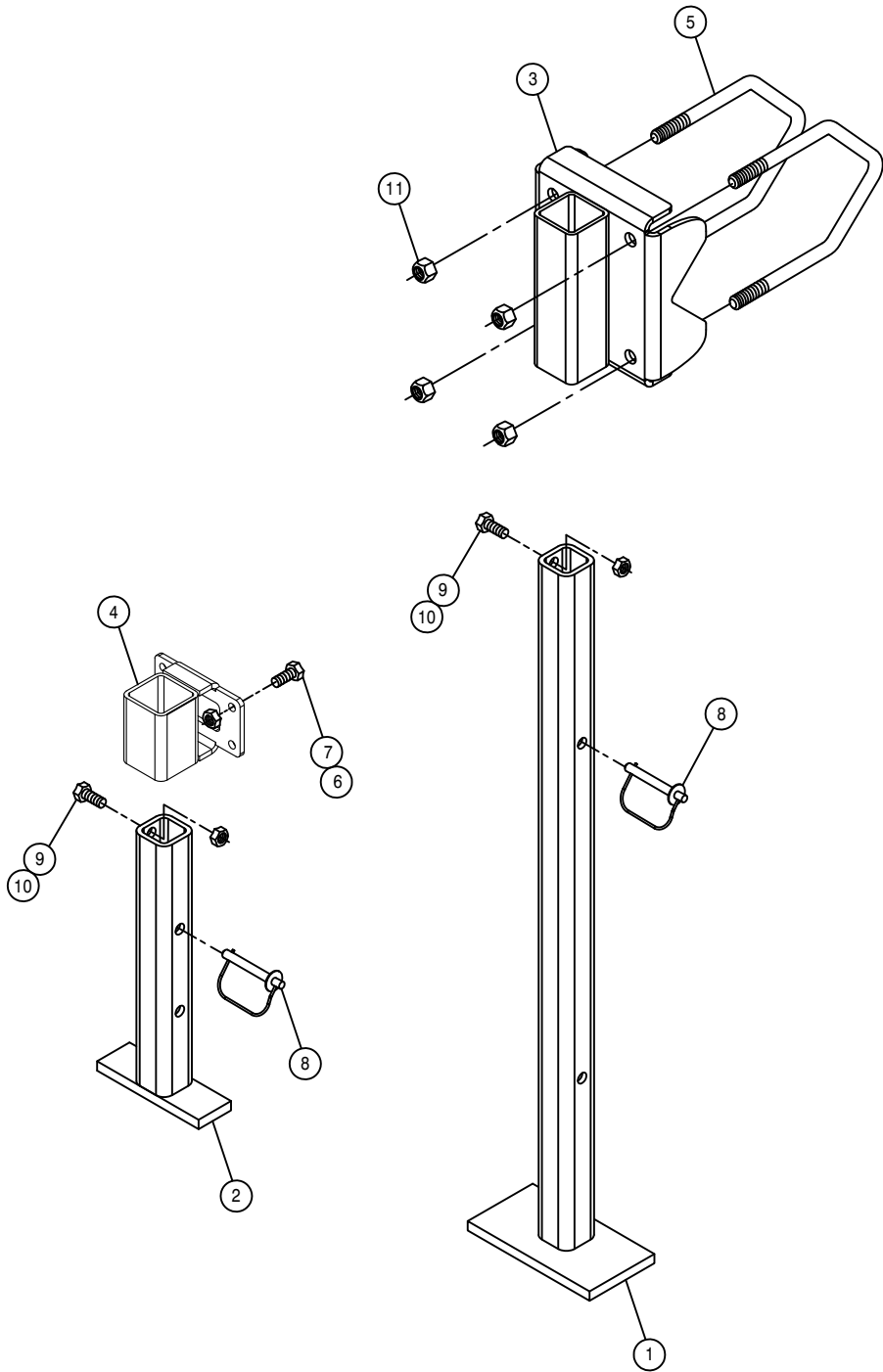

BOOM STAND OPTION

DET. QTY PART NO. DESCRIPTION

1	2	164787	TRANSOM STAND POST WLD, STS 04
2	2	164794	BOOM STAND POST WLD, STS 04
3	2	164855	TRANSOM STAND MT WLD, STS 05
4	2	164857	MAIN BOOM JACKSTAND WLD, STS 05
5	4	438293	5/8UNC X 6 1/4 CTR U-BOLT TRI
6	8	470087	3/8UNC HEX FLANGE LOCK NUT
7	8	470329	3/8UNC X 1 1/4 SER FLANGE BOLT
8	4	470361	SNAP LOCK PIN, 1/2 X 3 1/2
9	4	900263	1/2UNC X 1" HEX BOLT
10	4	914008	1/2UNC HEX STOVER NUT
11	8	914010	5/8UNC HEX STOVER NUT

15" SPACING 90' WET BOOM ASSEMBLY (SV)

DET. QTY PART NO. DESCRIPTION

DET.	QTY	PART NO.	DESCRIPTION
1	22	164859	CLAMP MT BRKT, WET BOOM, STS
2	1	165656	15" WET BOOM WLD,52.90 LG 09
3	1	165658	15" WET BOOM WLD,67.91 LG 09
4	2	165857	15" WET BOOM WLD, 124.40 LG
5	2	165662	15" WET BOOM WLD,155.63 LG 09
6	4	165654	15" WET BOOM WLD,50.20 LG 09
7	46	197116	HOSE 1IN 1-FBR BR BLK EPDM
8	28	470375	TUBE CLAMP BODY,1.31 ID (PAIR)
9	28	470376	COVER PLATE FOR 470375
10	4	500105	1.00 HOSE BARB TEE, POLY
11	2	500109	1.00-90-1.00 HOSE BARB, POLY
12	33	500157	1" FLANGE GASKET EPDM
13	33	500159	1" FLANGE CLAMP, S.S.
14	12	500173	1" FLANGE-90-1" HOSE BARB POLY
15	2	500174	1" FLANGE-90-1" FLANGE LBOPOLY
16	3	500175	1" FLANGE TEE POLY
17	2	520087	HOSE CLAMP NO 20 STAINLESS
18	26	520090	HOSE CLAMP NO 16 STAINLESS
19	2	690757	BALL VLV ASSY,1"FLG-1"HBARB
20	71	737921	QUICK TJET 3-TIP BODY,1" HV
21	48	900002	1/4UNC X 3/4 HEX BOLT
22	56	900010	1/4UNC X 3" HEX BOLT
23	10	914000	1/4UNC HEX STOVER NUT
24	10	920000	1/4 SAE FLAT WASHER
25	14	500155	1" FLANGE CAP PLUG POLY
26	2	164916	Z-BRKT, WET BOOM SECT 1, STS
27	1	165855	15" WET BOOM WLD, 49.40 LG
28	2	165928	15" WET BM TUBE WLD,5.10LG '11
29	2	165926	15" WET BOOM WLD,41.82LG '11

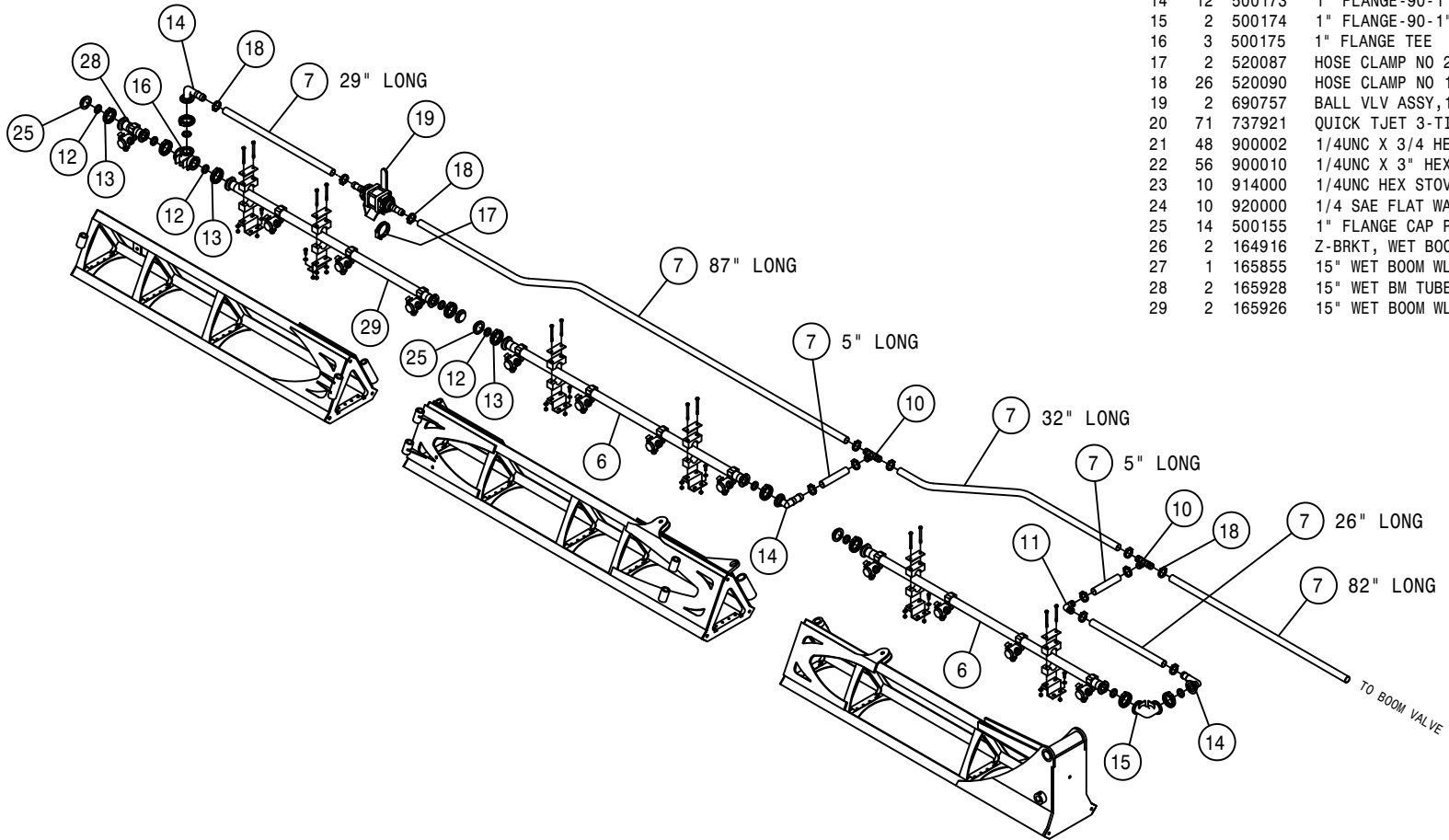

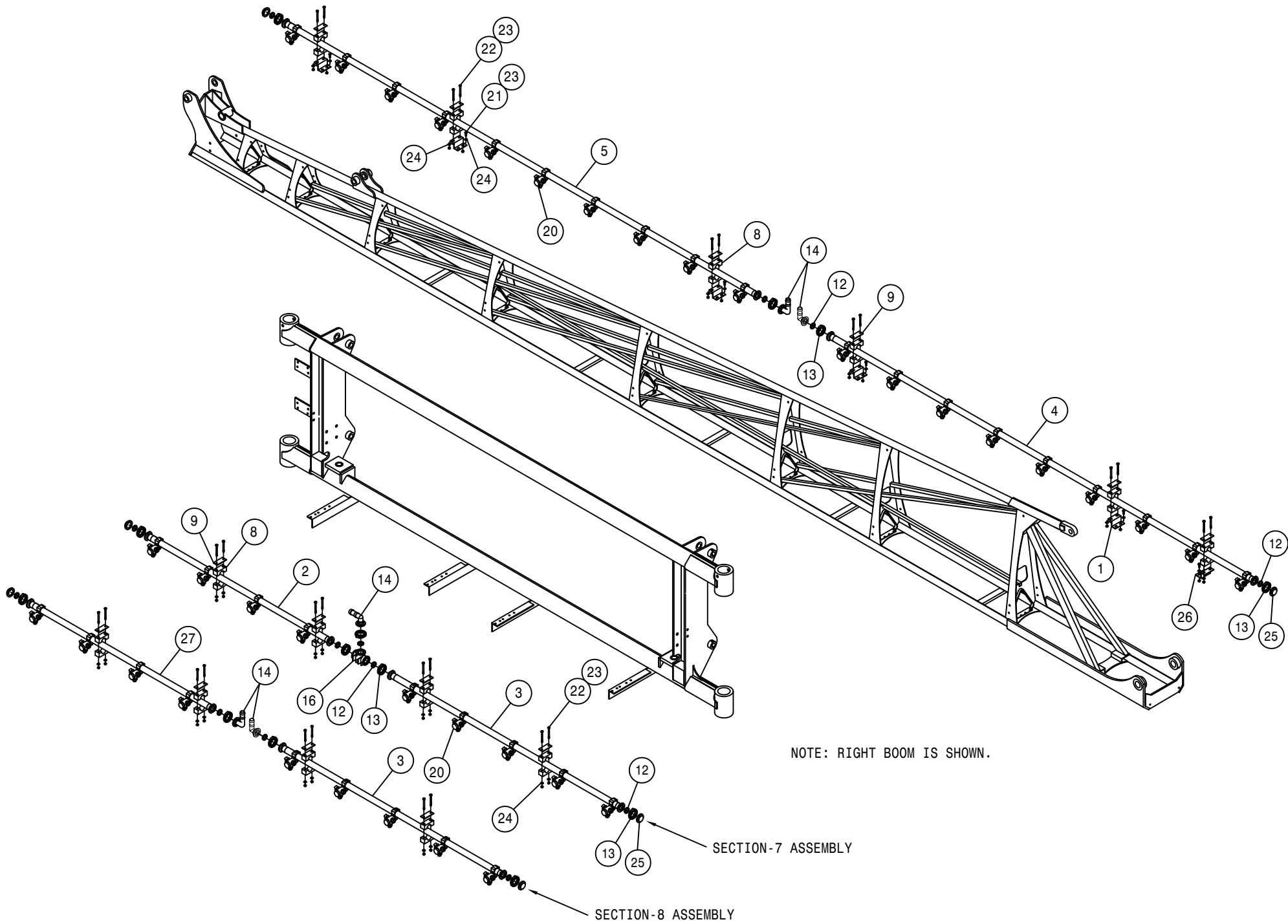

NOTE: RIGHT BOOM IS SHOWN.

SECTION-7 ASSEMBLY

SECTION-8 ASSEMBLY

15" SPACING 100' WET BOOM ASSEMBLY (SV)

DET.	QTY	PART NO.	DESCRIPTION
1	26	164859	CLAMP MT BRKT, WET BOOM, STS
2	5	165656	15" WET BOOM WLD,52.90 LG 09
3	1	165658	15" WET BOOM WLD,67.91 LG 09
4	2	165857	15" WET BOOM WLD, 124.40 LG
5	2	165662	15" WET BOOM WLD,155.63 LG 09
6	4	165654	15" WET BOOM WLD,50.20 LG 09
7	46	197116	HOSE 1IN 1-FBR BR BLK EPDM
8	32	470375	TUBE CLAMP BODY,1.31 ID (PAIR)
9	32	470376	COVER PLATE FOR 470375
10	4	500105	1.00 HOSE BARB TEE, POLY
11	2	500109	1.00-90-1.00 HOSE BARB, POLY
12	33	500157	1" FLANGE GASKET EPDM
13	33	500159	1" FLANGE CLAMP, S.S.
14	12	500173	1" FLANGE-90-1" HOSE BARB POLY
15	2	500174	1" FLANGE-90-1" FLANGE LBOPOLY
16	3	500175	1" FLANGE TEE POLY
17	2	520087	HOSE CLAMP NO 20 STAINLESS
18	26	520090	HOSE CLAMP NO 16 STAINLESS
19	2	690757	BALL VLV ASSY,1"FLG-1"HBARB
20	81	737921	QUICK TJET 3-TIP BODY,1" HV
21	56	900002	1/4UNC X 3/4 HEX BOLT
22	64	900010	1/4UNC X 3" HEX BOLT
23	12	914000	1/4UNC HEX STOVER NUT
24	12	920000	1/4 SAE FLAT WASHER
25	14	500155	1" FLANGE CAP PLUG POLY
26	2	164916	Z-BRKT, WET BOOM SECT 1, STS
27	1	165855	15" WET BOOM WLD, 49.40 LG

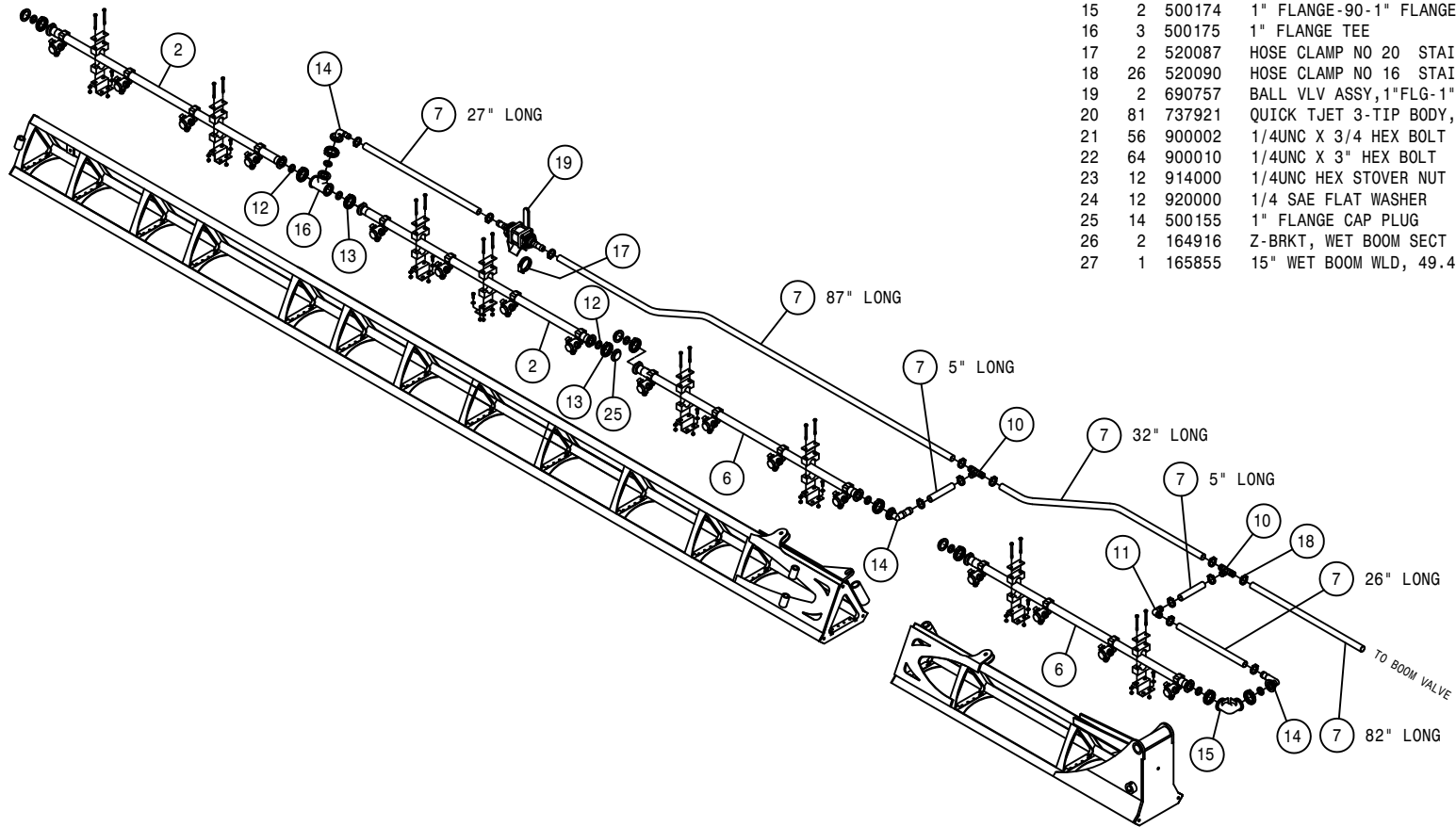

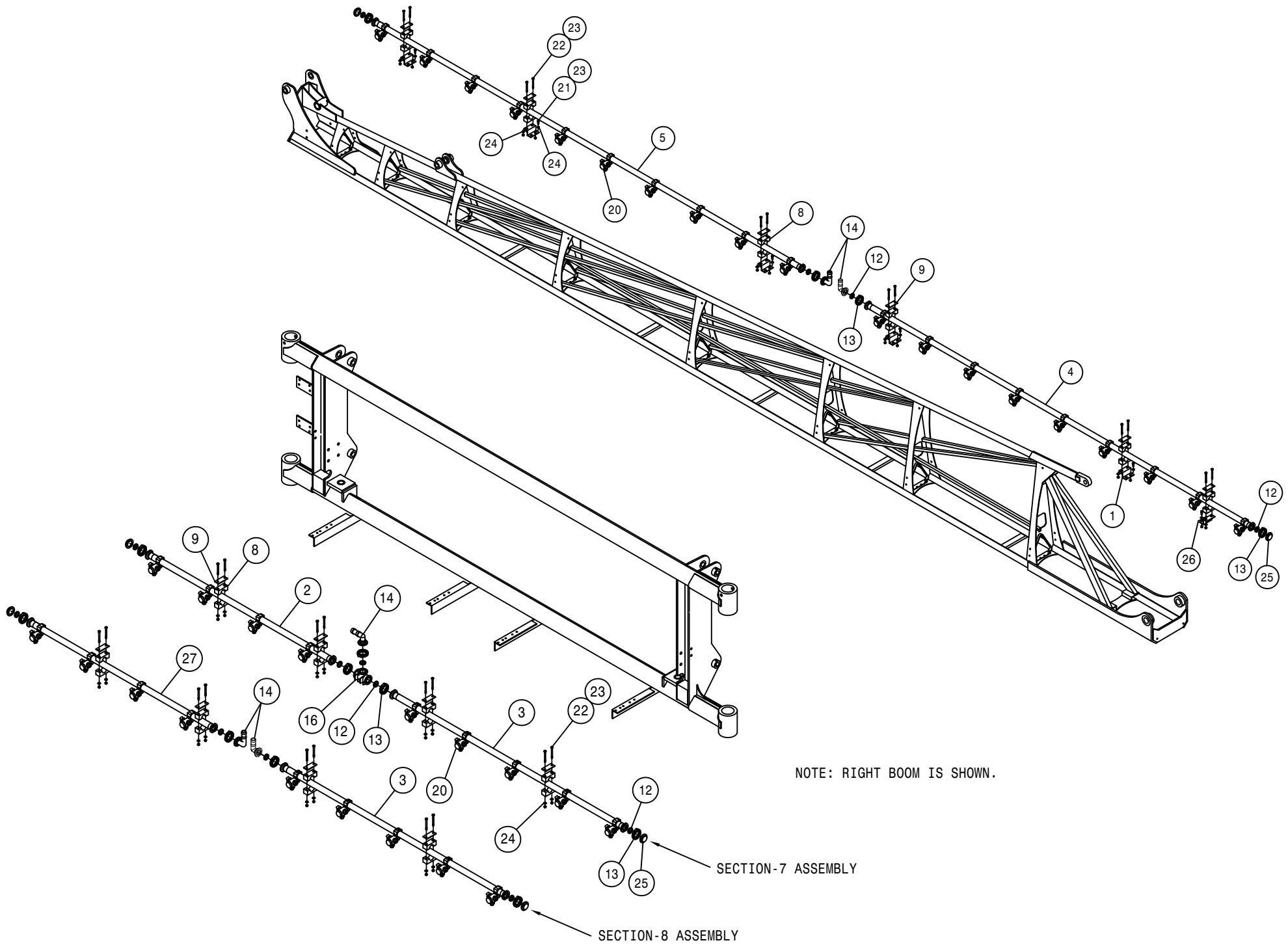

NOTE: RIGHT BOOM IS SHOWN.

SECTION-7 ASSEMBLY

SECTION-8 ASSEMBLY

20" SPACING 90' WET BOOM ASSEMBLY

DET. QTY PART NO. DESCRIPTION

DET.	QTY	PART NO.	DESCRIPTION
1	22	164859	CLAMP MT BRKT, WET BOOM, STS
2	1	165668	20" WET BOOM WLD,52.91 LG 09
3	1	165670	20" WET BOOM WLD,67.91 LG 09
4	2	165672	20" WET BOOM WLD,125.20 LG 09
5	1	165936	20" WET BOOM WLD,154.63 LG '11
6	6	165664	20" WET BOOM WLD,45.20 LG 09
7	46	197116	HOSE 1IN 1-FBR BR BLK EPDM
8	28	470375	TUBE CLAMP BODY,1.31 ID (PAIR)
9	28	470376	COVER PLATE FOR 470375
10	4	500105	1.00 HOSE BARB TEE, POLY
11	4	500109	1.00-90-1.00 HOSE BARB, POLY
12	29	500157	1" FLANGE GASKET EPDM
13	29	500159	1" FLANGE CLAMP, S.S.
14	12	500173	1" FLANGE-90-1" HOSE BARB POLY
15	4	500174	1" FLANGE-90-1" FLANGE LBOPOLY
16	1	500175	1" FLANGE TEE POLY
17	2	520087	HOSE CLAMP NO 20 STAINLESS
18	32	520090	HOSE CLAMP NO 16 STAINLESS
19	1	690752	RH BALL VLV ASSY,STD VOL 90'
20	55	737921	QUICK TJET 3-TIP BODY,1" HV
21	48	900002	1/4UNC X 3/4 HEX BOLT
22	56	900010	1/4UNC X 3" HEX BOLT
23	10	914000	1/4UNC HEX STOVER NUT
24	10	920000	1/4 SAE FLAT WASHER
25	1	690753	LH BALL VLV ASSY,STD VOL 90'
26	12	500155	1" FLANGE CAP PLUG POLY
27	2	164916	Z-BRKT, WET BOOM SECT 1, STS
28	1	165934	20" WET BOOM WLD,67.41 LG '11
29	1	165932	20" WET BOOM WLD,52.41 LG '11

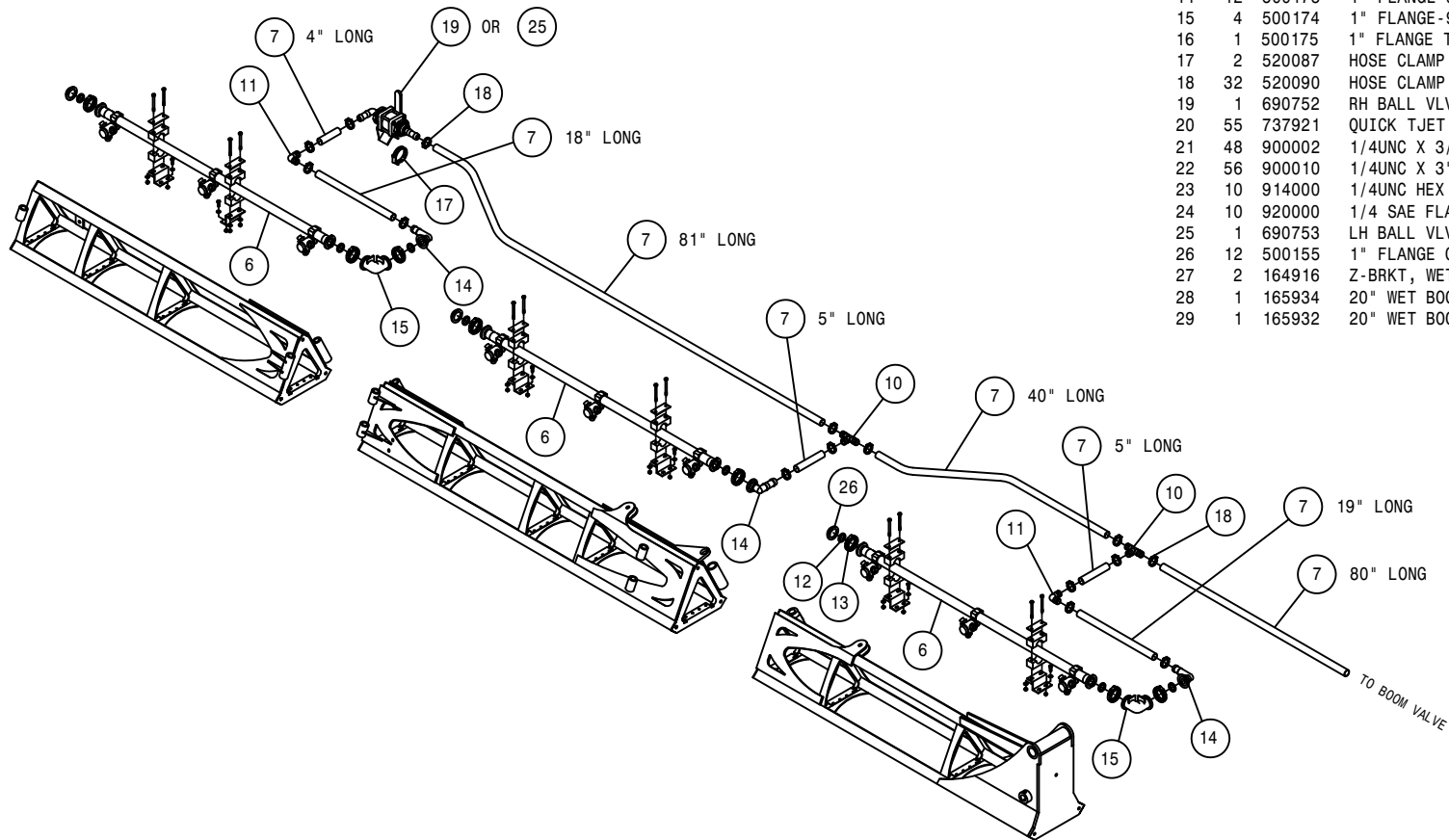

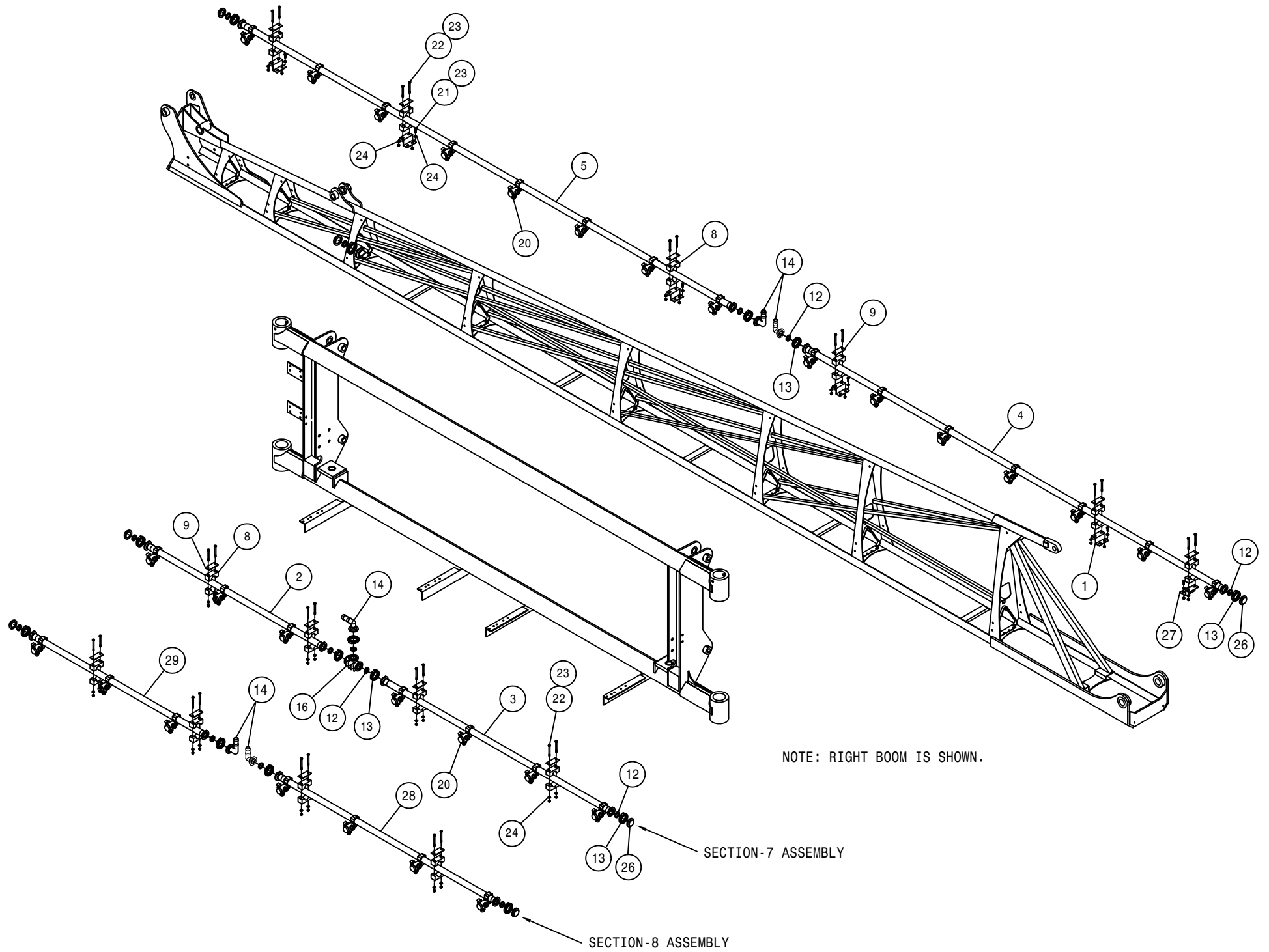

NOTE: RIGHT BOOM IS SHOWN.

SECTION-7 ASSEMBLY

SECTION-8 ASSEMBLY

20" SPACING 100' WET BOOM ASSEMBLY (SV)

DET. QTY PART NO. DESCRIPTION

1	26	164859	CLAMP MT BRKT, WET BOOM, STS
2	1	165668	20" WET BOOM WLD,52.91 LG 09
3	1	165670	20" WET BOOM WLD,67.91 LG 09
4	2	165672	20" WET BOOM WLD,125.20 LG 09
5	2	165936	20" WET BOOM WLD,154.63 LG '11
6	4	165664	20" WET BOOM WLD,45.20 LG 09
7	46	197116	HOSE 1IN 1-FBR BR BLK EPDM
8	32	470375	TUBE CLAMP BODY,1.31 ID (PAIR)
9	32	470376	COVER PLATE FOR 470375
10	4	500105	1.00 HOSE BARB TEE, POLY
11	2	500109	1.00-90-1.00 HOSE BARB, POLY
12	33	500157	1" FLANGE GASKET EPDM
13	33	500159	1" FLANGE CLAMP, S.S.
14	12	500173	1" FLANGE-90-1" HOSE BARB POLY
15	2	500174	1" FLANGE-90-1" FLANGE LBOPOLY
16	3	500175	1" FLANGE TEE POLY
17	2	520087	HOSE CLAMP NO 20 STAINLESS
18	24	520090	HOSE CLAMP NO 16 STAINLESS
19	2	690757	BALL VLV ASSY,1"FLG-1"HBARB
20	61	737921	QUICK TJET 3-TIP BODY,1" HV
21	56	900002	1/4UNC X 3/4 HEX BOLT
22	64	900010	1/4UNC X 3" HEX BOLT
23	12	914000	1/4UNC HEX STOVER NUT
24	12	920000	1/4 SAE FLAT WASHER
25	4	165666	20" WET BOOM WLD,50.41 LG 09
26	14	500155	1" FLANGE CAP PLUG POLY
27	2	164916	Z-BRKT, WET BOOM SECT 1, STS
28	1	165932	20" WET BOOM WLD,52.41 LG '11
29	1	165934	20" WET BOOM WLD,67.41 LG '11

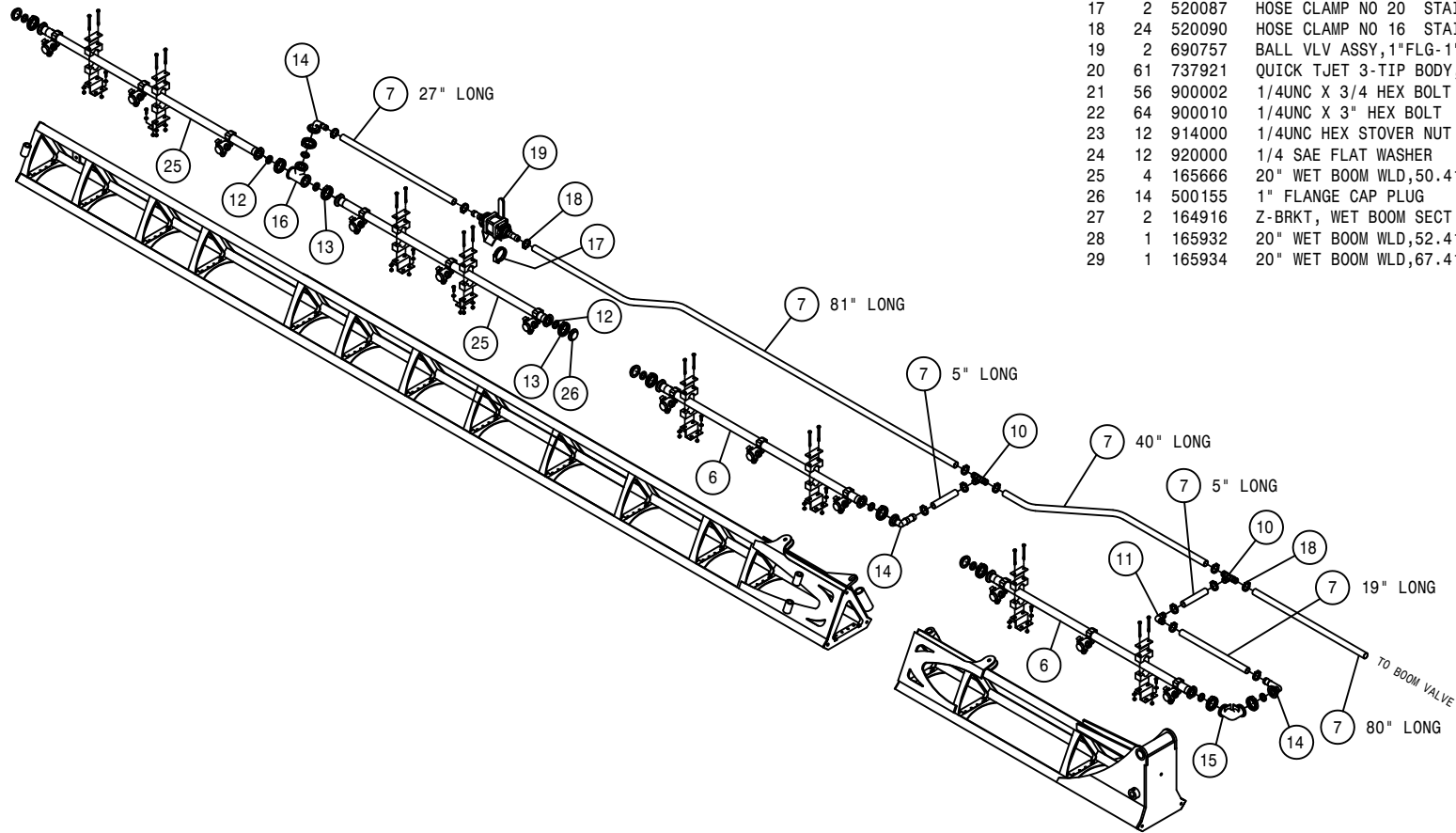

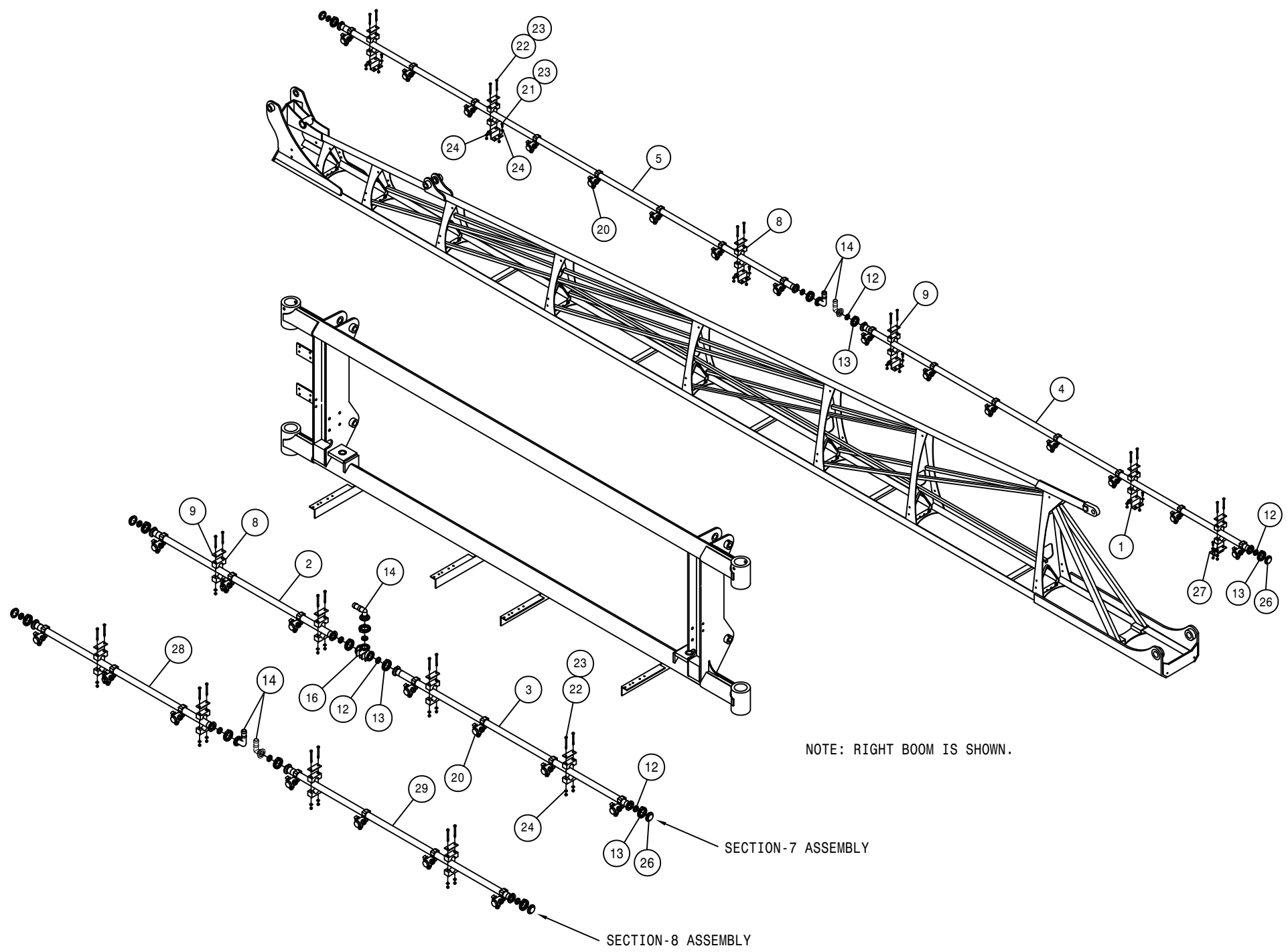

NOTE: RIGHT BOOM IS SHOWN.

SECTION-7 ASSEMBLY

SECTION-8 ASSEMBLY

15" SPACING 90' WET BOOM ASSEMBLY (HV)

DET. QTY PART NO. DESCRIPTION

DET.	QTY	PART NO.	DESCRIPTION
1	22	164859	CLAMP MT BRKT, WET BOOM, STS
2	1	165656	15" WET BOOM WLD,52.90 LG 09
3	1	165658	15" WET BOOM WLD,67.91 LG 09
4	2	165857	15" WET BOOM WLD, 124.40 LG
5	2	165662	15" WET BOOM WLD,155.63 LG 09
6	4	165654	15" WET BOOM WLD,50.20 LG 09
7	46	197116	HOSE 1IN 1-FBR BR BLK EPDM
8	28	470375	TUBE CLAMP BODY,1.31 ID (PAIR)
9	28	470376	COVER PLATE FOR 470375
10	2	500105	1.00 HOSE BARB TEE, POLY
11	2	500109	1.00-90-1.00 HOSE BARB, POLY
12	38	500157	1" FLANGE GASKET EPDM
13	38	500159	1" FLANGE CLAMP, S.S.
14	12	500173	1" FLANGE-90-1" HOSE BARB POLY
15	2	500174	1" FLANGE-90-1" FLANGE LBOPOLY
16	5	500175	1" FLANGE TEE POLY
17	2	520087	HOSE CLAMP NO 20 STAINLESS
18	24	520090	HOSE CLAMP NO 16 STAINLESS
19	2	690757	BALL VLV ASSY,1"FLG-1"HBARB
20	71	737921	QUICK TJET 3-TIP BODY,1" HV
21	48	900002	1/4UNC X 3/4 HEX BOLT
22	56	900010	1/4UNC X 3" HEX BOLT
23	10	914000	1/4UNC HEX STOVER NUT
24	10	920000	1/4 SAE FLAT WASHER
25	2	165928	15" WET BM TUBE WLD,5.10LG '11
26	2	500158	1 1/2" GASKET FOR 2" FLANGE
27	2	500160	2" FLANGE CLAMP, S.S.
28	2	500161	2"FLANGE-1"FLANGE COUPLER,POLY
29	2	500162	2" FLANGE-1 1/2 HOSE BARB POLY
30	4	500171	1" FLANGE-1" HOSE BARB POLY
31	14	500155	1" FLANGE CAP PLUG POLY
32	2	164916	Z-BRKT, WET BOOM SECT 1, STS
33	1	165853	15" WET BOOM WLD, 64.40 LG
34	2	165926	15" WET BOOM WLD,41.82LG '11

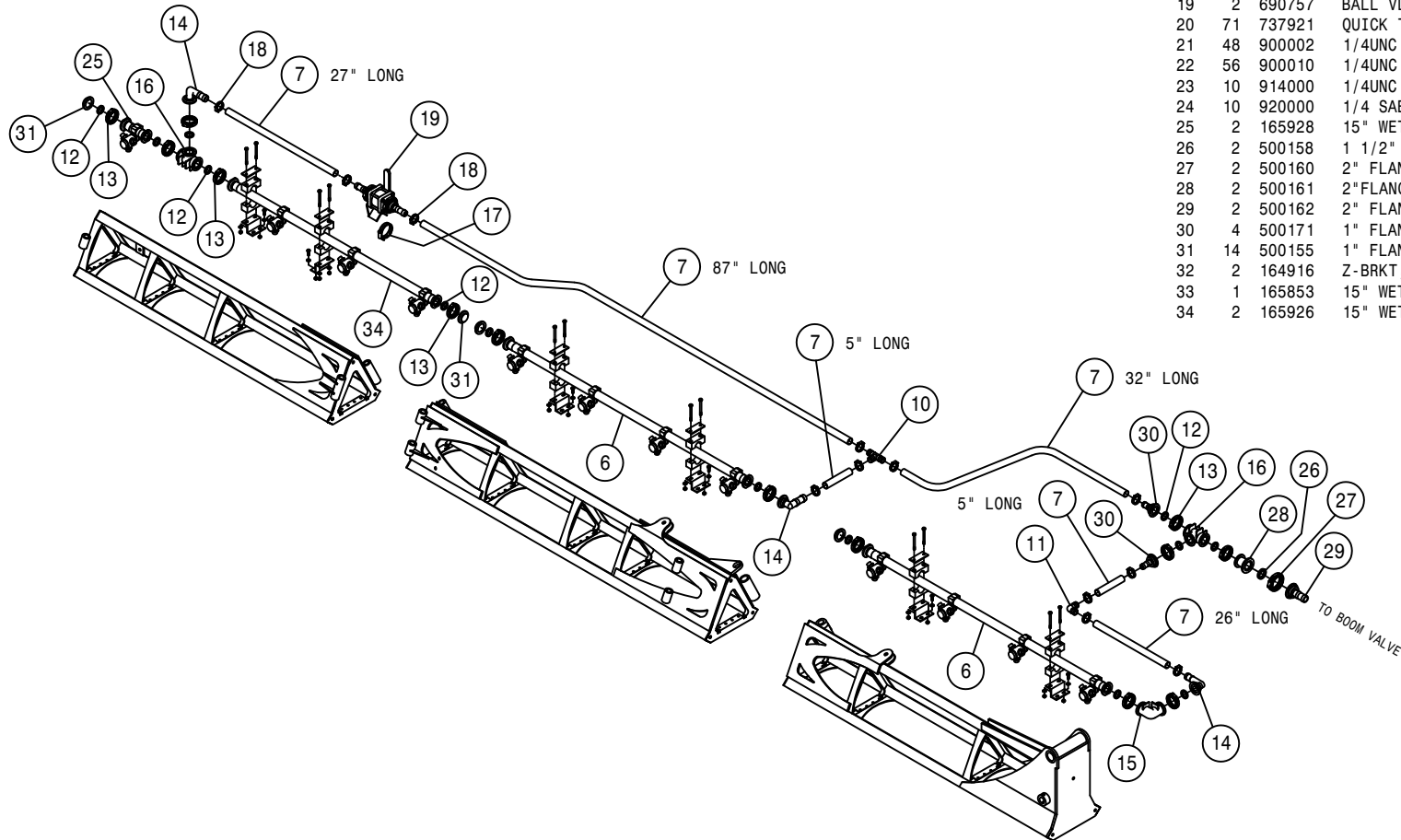

134

508134

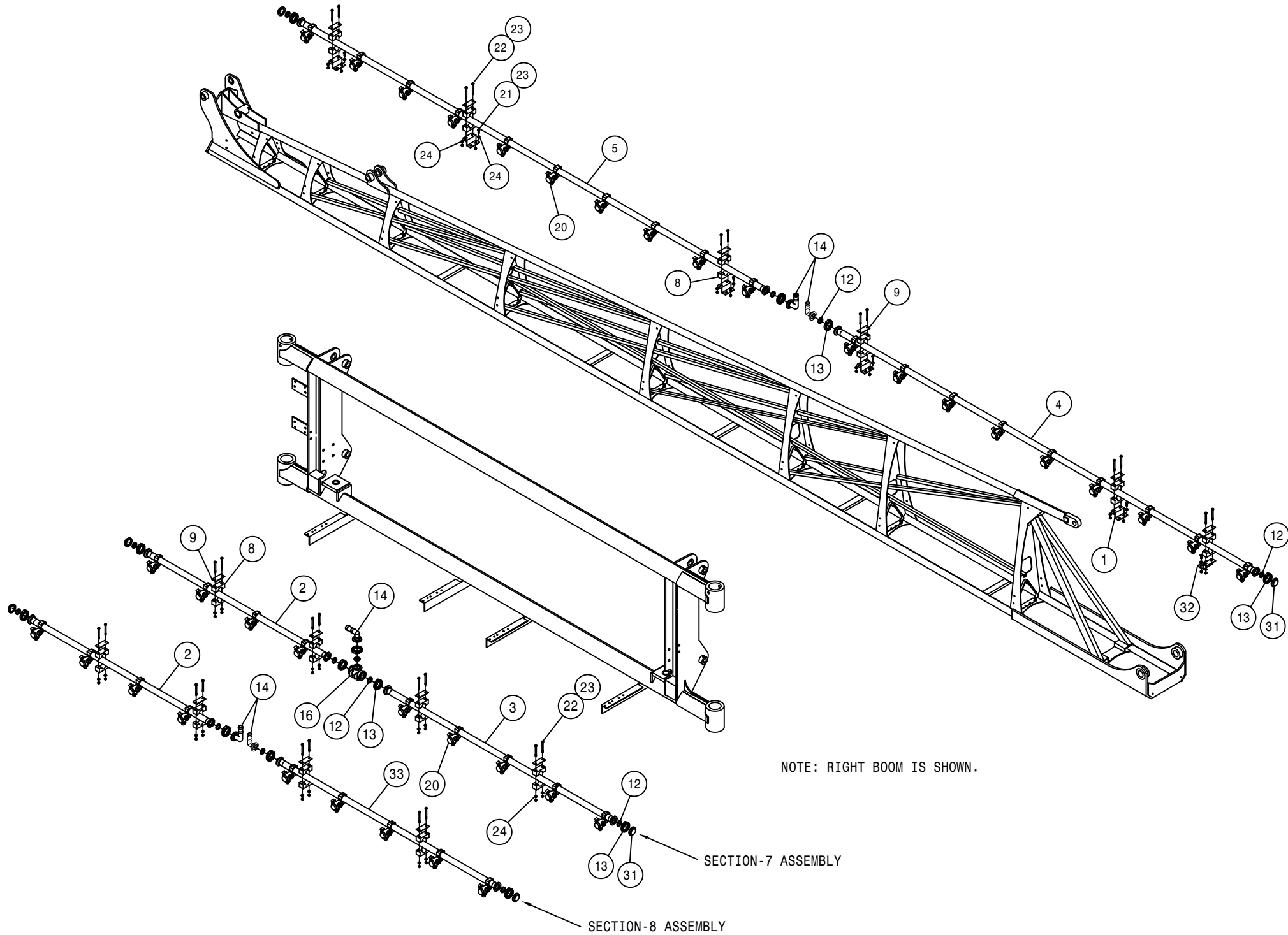

NOTE: RIGHT BOOM IS SHOWN.

SECTION-7 ASSEMBLY

SECTION-8 ASSEMBLY

15" SPACING 100' WET BOOM ASSEMBLY (HV)

DET. QTY PART NO. DESCRIPTION

DET.	QTY	PART NO.	DESCRIPTION
1	26	164859	CLAMP MT BRKT, WET BOOM, STS
2	5	165656	15" WET BOOM WLD, 52.90 LG 09
3	1	165658	15" WET BOOM WLD, 67.91 LG 09
4	2	165857	15" WET BOOM WLD, 124.40 LG
5	2	165662	15" WET BOOM WLD, 155.63 LG 09
6	4	165654	15" WET BOOM WLD, 50.20 LG 09
7	46	197116	HOSE 1IN 1-FBR BR BLK EPDM
8	32	470375	TUBE CLAMP BODY, 1.31 ID (PAIR)
9	32	470376	COVER PLATE FOR 470375
10	2	500105	1.00 HOSE BARB TEE, POLY
11	2	500109	1.00-90-1.00 HOSE BARB, POLY
12	39	500157	1" FLANGE GASKET EPDM
13	39	500159	1" FLANGE CLAMP, S.S.
14	12	500173	1" FLANGE-90-1" HOSE BARB POLY
15	2	500174	1" FLANGE-90-1" FLANGE LBOPOLY
16	5	500175	1" FLANGE TEE POLY
17	2	520087	HOSE CLAMP NO 20 STAINLESS
18	24	520090	HOSE CLAMP NO 16 STAINLESS
19	2	690757	BALL VLV ASSY, 1" FLG-1" HBARB
20	81	737921	QUICK TJET 3-TIP BODY, 1" HV
21	56	900002	1/4UNC X 3/4 HEX BOLT
22	64	900010	1/4UNC X 3" HEX BOLT
23	12	914000	1/4UNC HEX STOVER NUT
24	12	920000	1/4 SAE FLAT WASHER
25	1	165853	15" WET BOOM WLD, 64.40 LG
26	2	500158	1 1/2" GASKET FOR 2" FLANGE
27	2	500160	2" FLANGE CLAMP, S.S.
28	2	500161	2" FLANGE-1" FLANGE COUPLER, POLY
29	2	500162	2" FLANGE-1 1/2 HOSE BARB POLY
30	4	500171	1" FLANGE-1" HOSE BARB POLY
31	14	500155	1" FLANGE CAP PLUG POLY
32	2	164916	Z-BRKT, WET BOOM SECT 1, STS

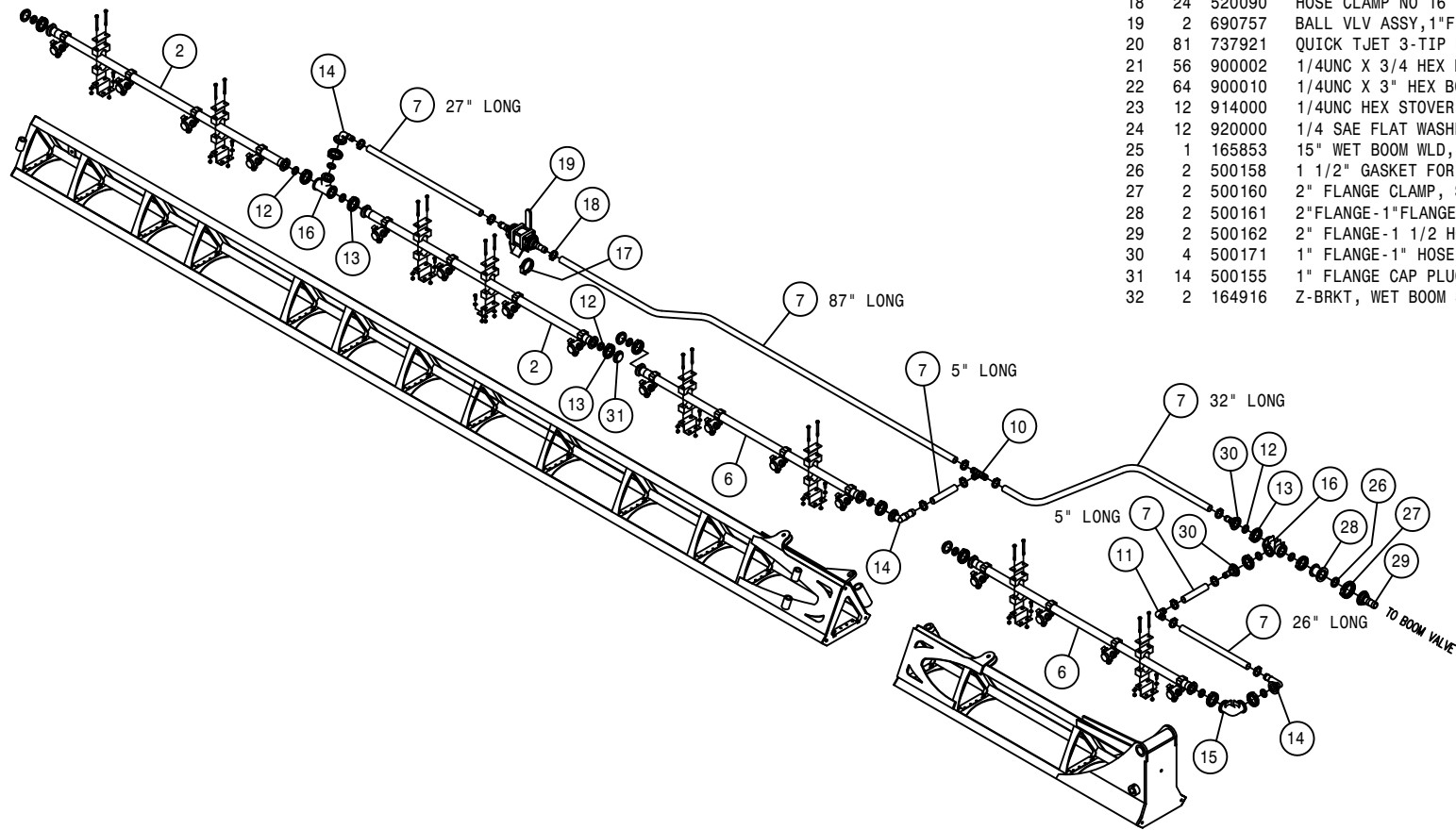

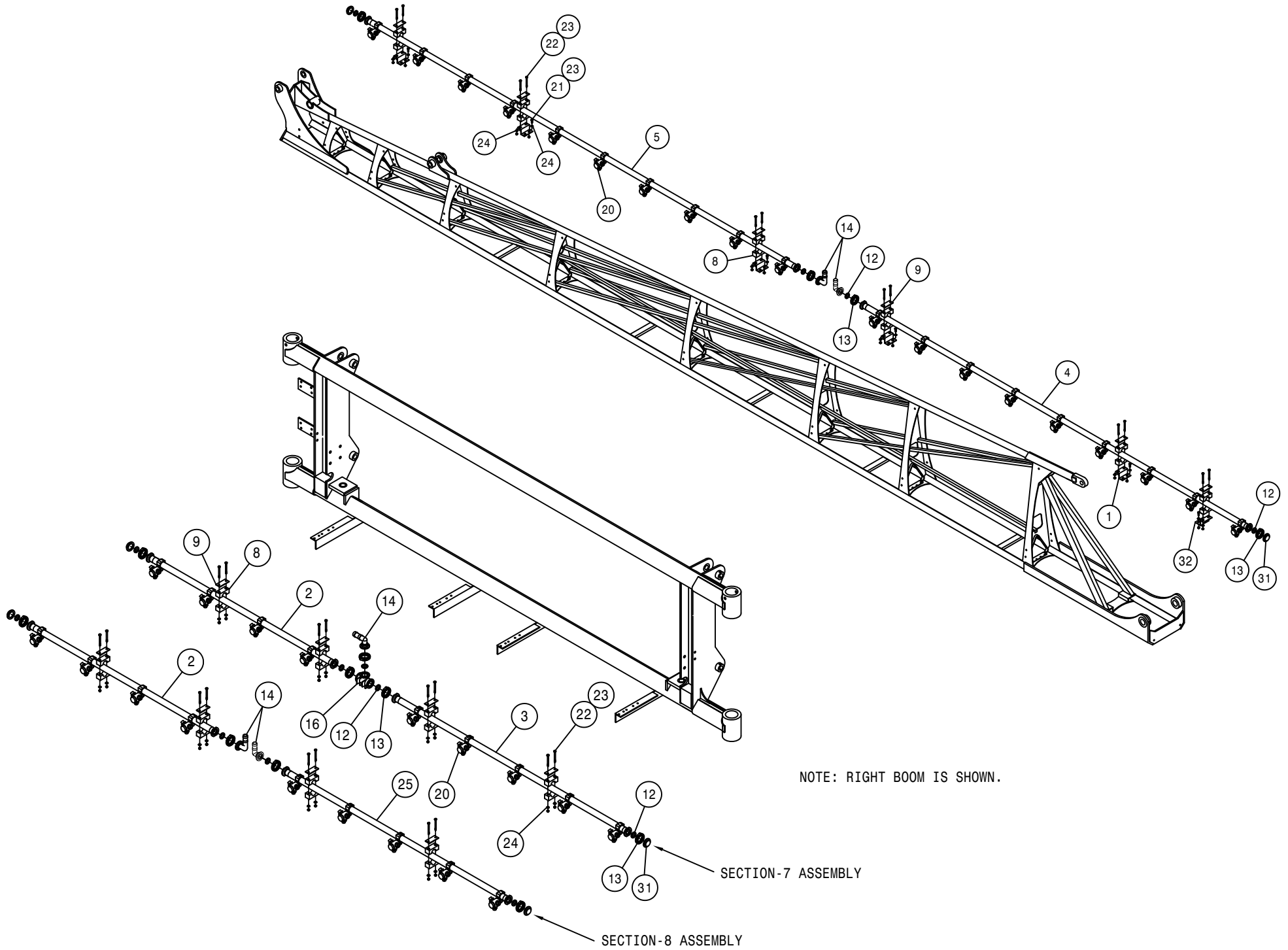

NOTE: RIGHT BOOM IS SHOWN.

SECTION-7 ASSEMBLY

SECTION-8 ASSEMBLY

20" SPACING 90' WET BOOM ASSEMBLY (HV)

DET. QTY PART NO. DESCRIPTION

DET.	QTY	PART NO.	DESCRIPTION
1	22	164859	CLAMP MT BRKT, WET BOOM, STS
2	1	165668	20" WET BOOM WLD,52.91 LG 09
3	1	165670	20" WET BOOM WLD,67.91 LG 09
4	2	165672	20" WET BOOM WLD,125.20 LG 09
5	2	165936	20" WET BOOM WLD,154.63 LG '11
6	6	165664	20" WET BOOM WLD,45.20 LG 09
7	46	197116	HOSE 1IN 1-FBR BR BLK EPDM
8	28	470375	TUBE CLAMP BODY,1.31 ID (PAIR)
9	28	470376	COVER PLATE FOR 470375
10	2	500105	1.00 HOSE BARB TEE, POLY
11	4	500109	1.00-90-1.00 HOSE BARB, POLY
12	35	500157	1" FLANGE GASKET EPDM
13	35	500159	1" FLANGE CLAMP, S.S.
14	12	500173	1" FLANGE-90-1" HOSE BARB POLY
15	4	500174	1" FLANGE-90-1" FLANGE LBOPOLY
16	3	500175	1" FLANGE TEE POLY
17	2	520087	HOSE CLAMP NO 20 STAINLESS
18	28	520090	HOSE CLAMP NO 16 STAINLESS
19	1	690752	RH BALL VLV ASSY,STD VOL 90'
20	55	737921	QUICK TJET 3-TIP BODY,1" HV
21	48	900002	1/4UNC X 3/4 HEX BOLT
22	56	900010	1/4UNC X 3" HEX BOLT
23	10	914000	1/4UNC HEX STOVER NUT
24	10	920000	1/4 SAE FLAT WASHER
25	1	165934	20" WET BOOM WLD,67.41 LG '11
26	2	500158	1 1/2" GASKET FOR 2" FLANGE
27	2	500160	2" FLANGE CLAMP, S.S.
28	2	500161	2"FLANGE-1"FLANGE COUPLER,POLY
29	2	500162	2" FLANGE-1 1/2 HOSE BARB POLY
30	4	500171	1" FLANGE-1" HOSE BARB POLY
31	1	690753	LH BALL VLV ASSY,STD VOL 90'
32	12	500155	1" FLANGE CAP PLUG POLY
33	2	164916	Z-BRKT, WET BOOM SECT 1, STS
34	1	165932	20" WET BOOM WLD,52.41 LG '11

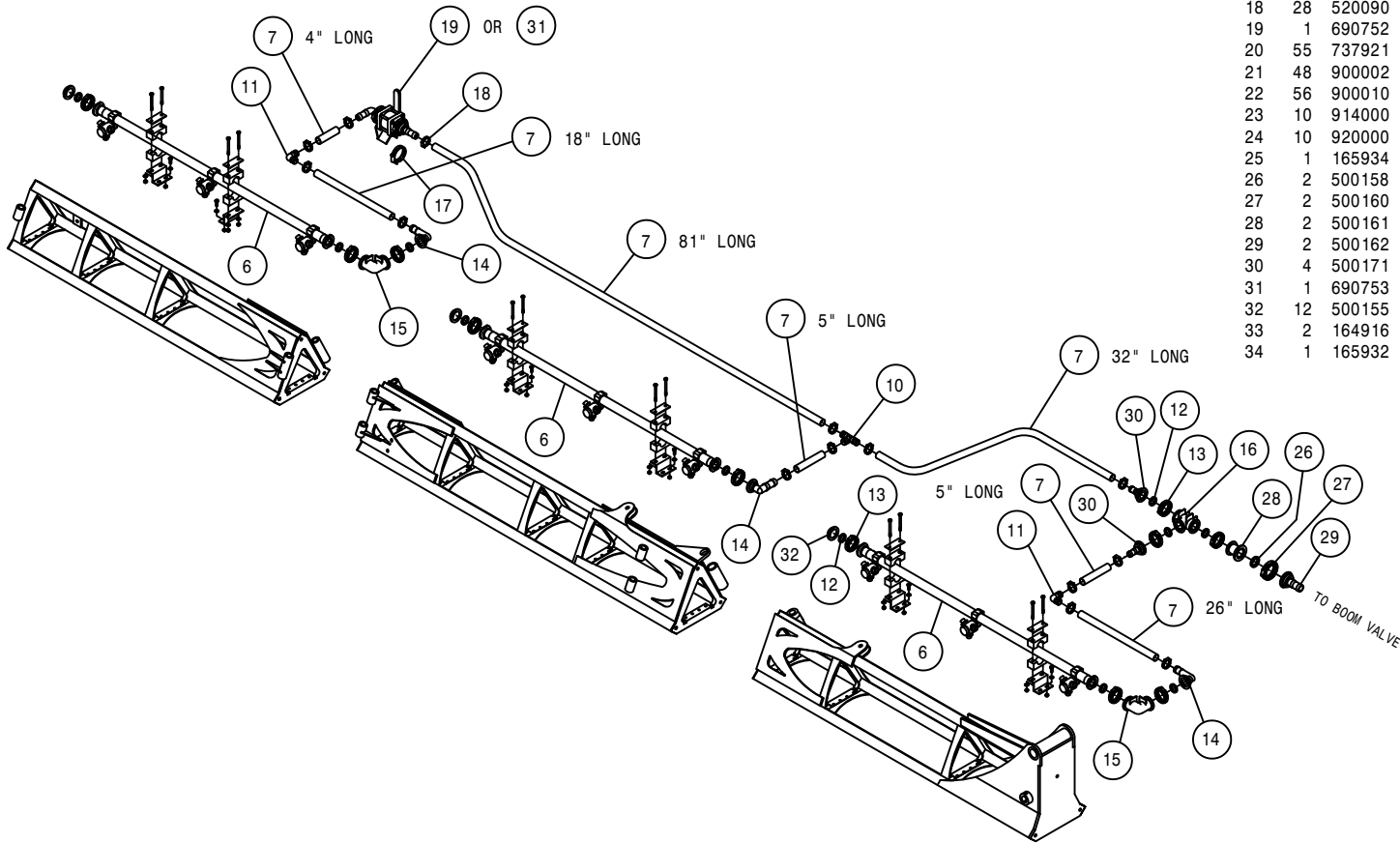

138

508138

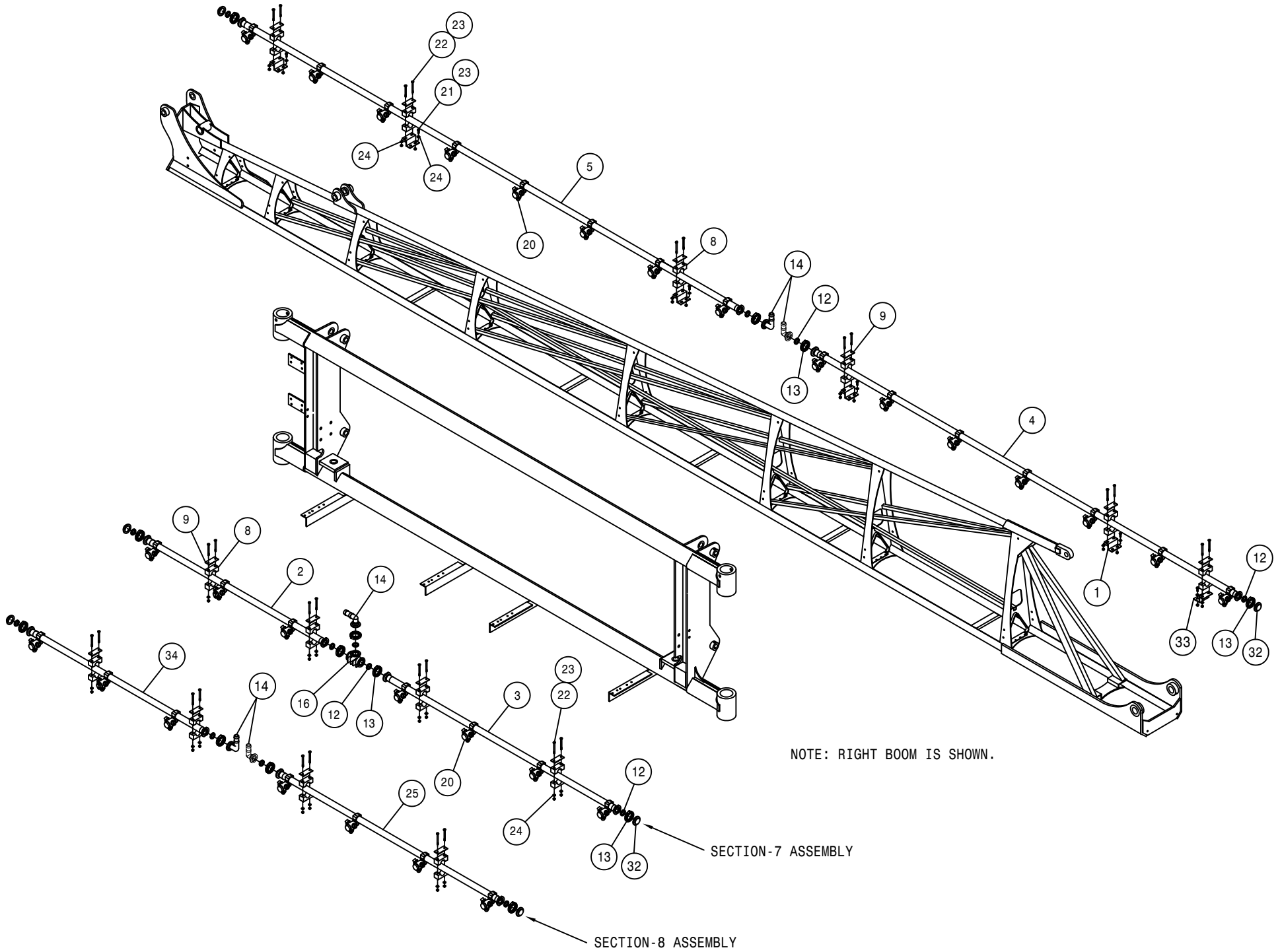

NOTE: RIGHT BOOM IS SHOWN.

SECTION-7 ASSEMBLY

SECTION-8 ASSEMBLY

20" SPACING 100' WET BOOM ASSEMBLY (HV)

DET. QTY PART NO. DESCRIPTION

DET.	QTY	PART NO.	DESCRIPTION
1	26	164859	CLAMP MT BRKT, WET BOOM, STS
2	1	165668	20" WET BOOM WLD, 52.91 LG '09
3	1	165670	20" WET BOOM WLD, 67.91 LG '09
4	2	165672	20" WET BOOM WLD, 125.20 LG '09
5	2	165936	20" WET BOOM WLD, 154.63 LG '11
6	4	165664	20" WET BOOM WLD, 45.20 LG '09
7	46	197116	HOSE 1IN 1-FBR BR BLK EPDM
8	32	470375	TUBE CLAMP BODY, 1.31 ID (PAIR)
9	32	470376	COVER PLATE FOR 470375
10	2	500105	1.00 HOSE BARB TEE, POLY
11	2	500109	1.00-90-1.00 HOSE BARB, POLY
12	39	500157	1" FLANGE GASKET EPDM
13	39	500159	1" FLANGE CLAMP, S.S.
14	12	500173	1" FLANGE-90-1" HOSE BARB POLY
15	2	500174	1" FLANGE-90-1" FLANGE LBOPOLY
16	5	500175	1" FLANGE TEE POLY
17	2	520087	HOSE CLAMP NO 20 STAINLESS
18	20	520090	HOSE CLAMP NO 16 STAINLESS
19	2	690757	BALL VLV ASSY, 1" FLG-1" HBARB
20	61	737921	QUICK TJET 3-TIP BODY, 1" HV
21	56	900002	1/4UNC X 3/4 HEX BOLT
22	64	900010	1/4UNC X 3" HEX BOLT
23	12	914000	1/4UNC HEX STOVER NUT
24	12	920000	1/4 SAE FLAT WASHER
25	1	165934	20" WET BOOM WLD, 67.41 LG '11
26	2	500158	1 1/2" GASKET FOR 2" FLANGE
27	2	500160	2" FLANGE CLAMP, S.S.
28	2	500161	2" FLANGE-1" FLANGE COUPLER, POLY
29	2	500162	2" FLANGE-1 1/2 HOSE BARB POLY
30	4	500171	1" FLANGE-1" HOSE BARB POLY
31	4	165666	20" WET BOOM WLD, 50.41 LG '09
32	14	500155	1" FLANGE CAP PLUG POLY
33	2	164916	Z-BRKT, WET BOOM SECT 1, STS
34	1	165932	20" WET BOOM WLD, 52.41 LG '11

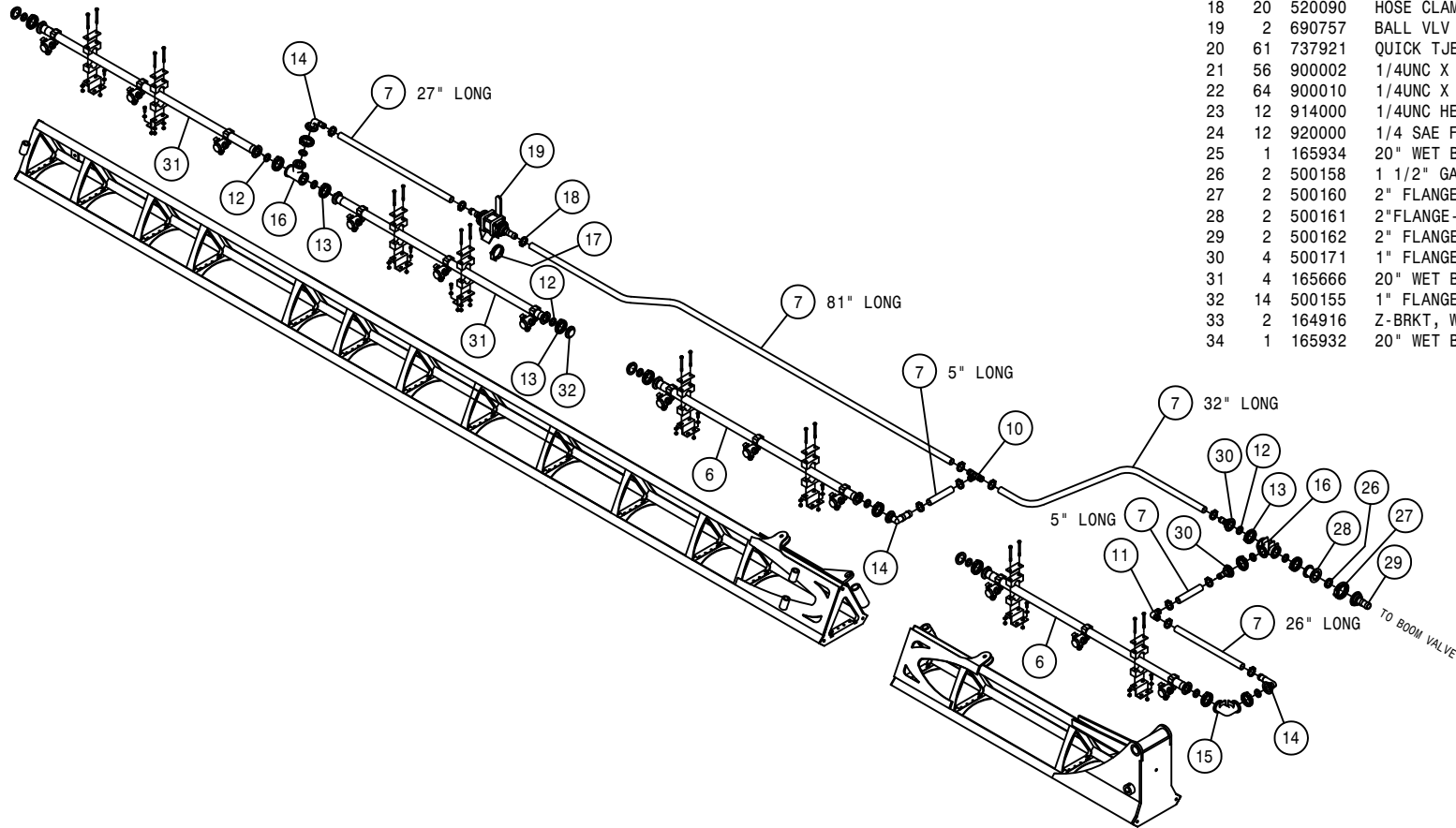

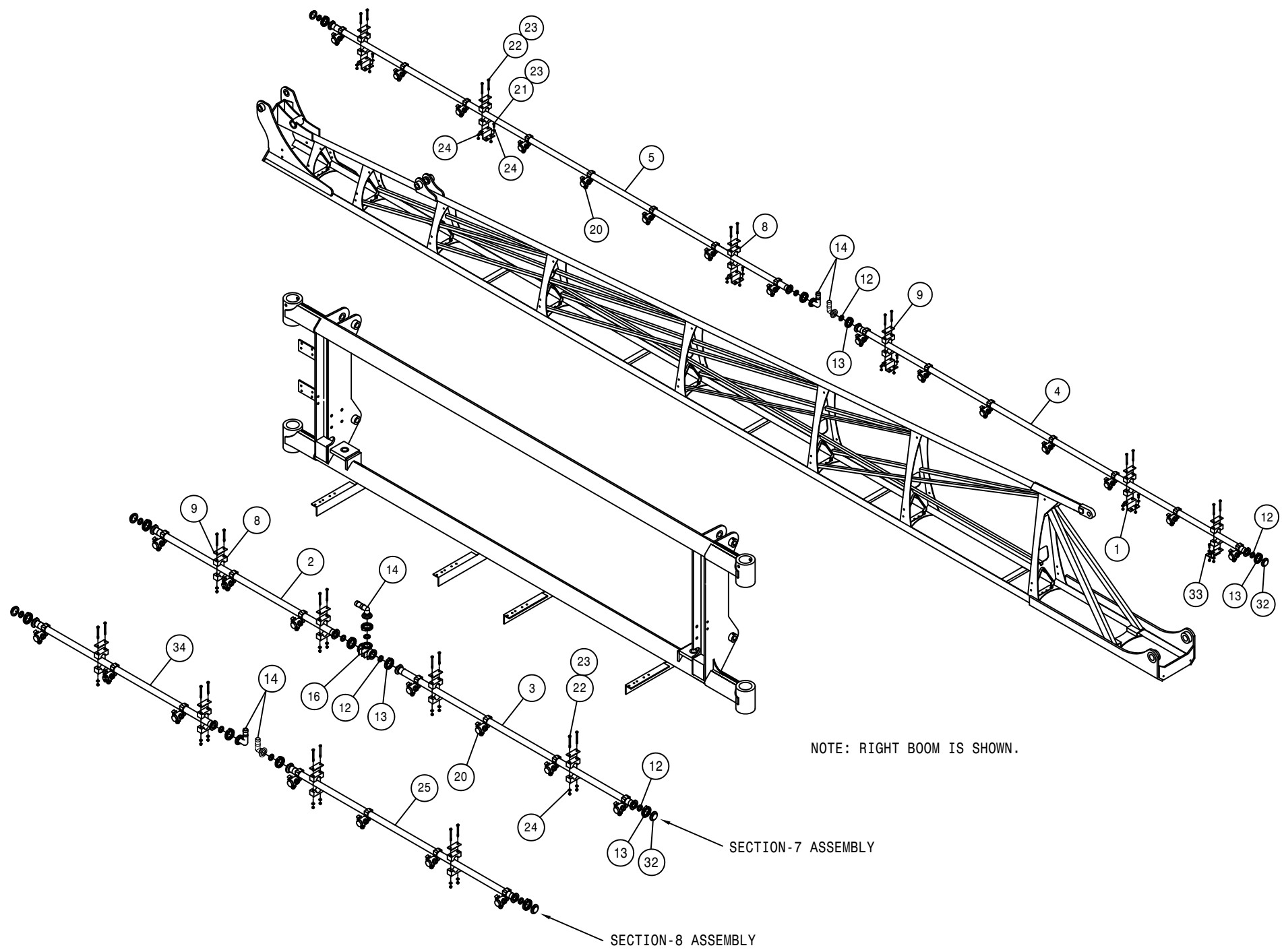

NOTE: RIGHT BOOM IS SHOWN.

SECTION-7 ASSEMBLY

SECTION-8 ASSEMBLY

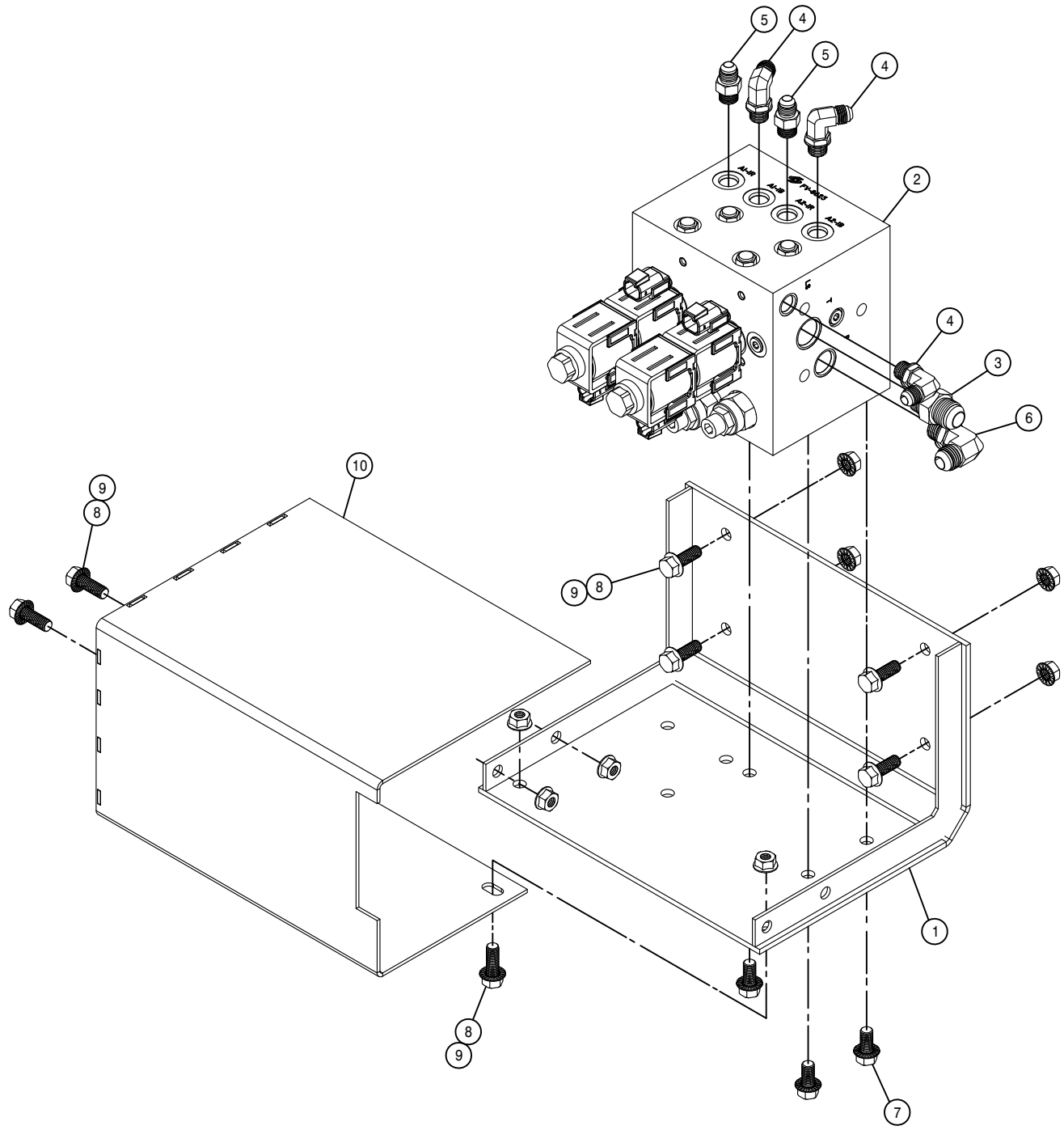

AWS HYDRAULIC VALVE ASSEMBLY

DET.	QTY	PART NO.	DESCRIPTION	
1	1	361872	AWS VALVE MT WLDMT, STS	09
2	1	606370	VALVE, FV8623 V1 SUNSOURCE	
3	1	611126	7/8MJIC-7/8MOR ADPTR	
4	3	618119	9/16MJIC-90-9/16MOR LBO	
5	2	618126	9/16MJIC-9/16MOR ADPTR	
6	1	618241	3/4MJIC-90-3/4MOR LBO	
7	3	900128	3/8UNC X 3/4 HEX BOLT	
8	8	900129	3/8UNC X 1" SERR FLANGE BOLT	
9	8	470087	3/8UNC HEX FLANGE LOCK NUT	
10	1	361908	AWS MANIF COVER WLD	

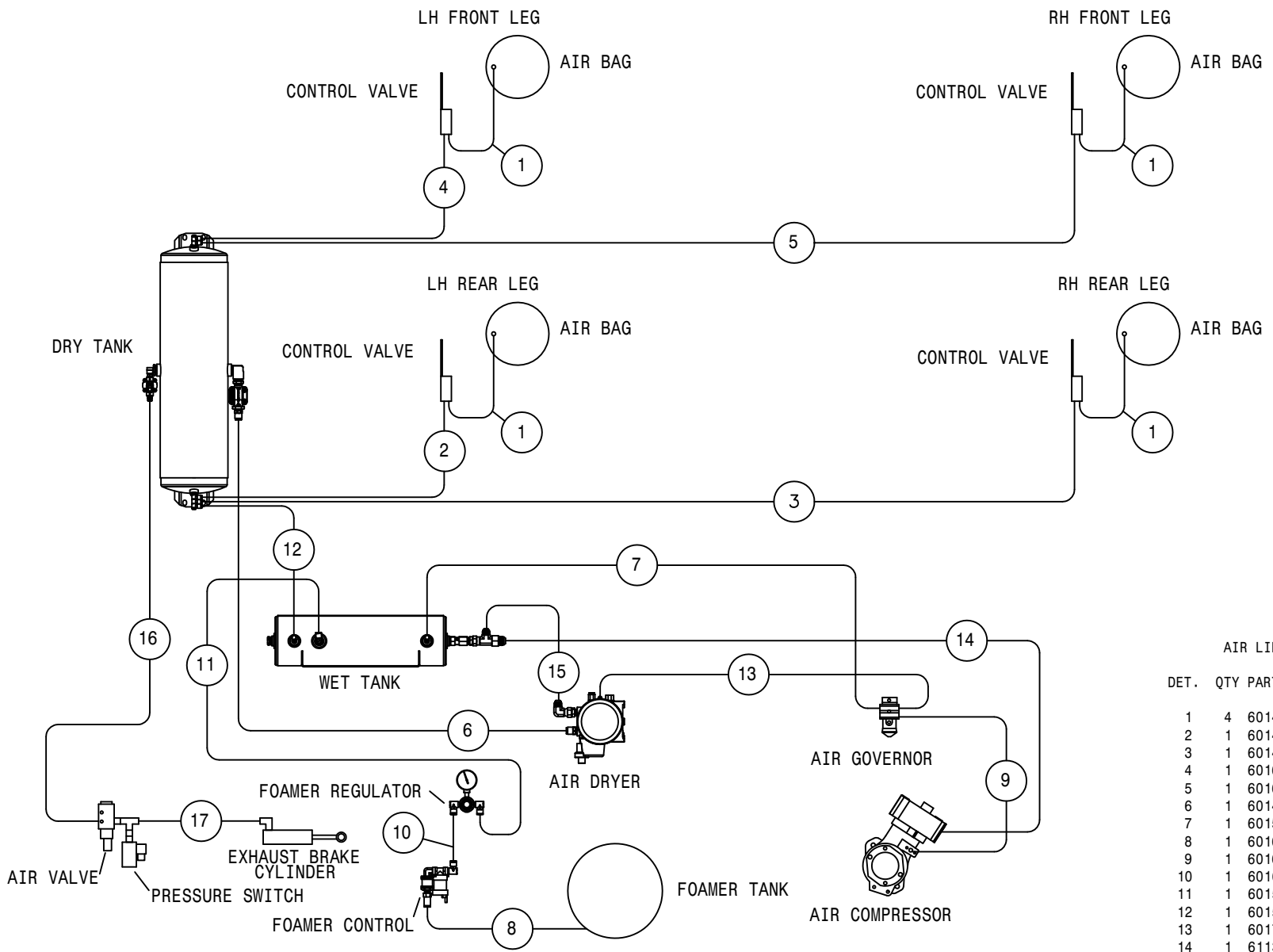

AIR LINE DIAGRAM STS 14 08

DET.	QTY	PART NO.	DESCRIPTION
1	4	601473	HOSE, 1/4 X 18 AIR
2	1	601476	HOSE, 1/4 X 120 AIR
3	1	601478	HOSE, 1/4 X 175 AIR
4	1	601641	HOSE, 1/4 X 222 AIR
5	1	601642	HOSE, 1/4 X 256 AIR
6	1	601483	HOSE, 1/2 X 84 AIR
7	1	601554	HOSE, 1/4 X 46 AIR
8	1	601624	HOSE, 3/8 X 60 AIR
9	1	601625	HOSE, 1/4 X 14 AIR
10	1	601633	HOSE, 3/8 X 11 AIR
11	1	601587	HOSE, 3/8 X 102 AIR
12	1	601592	HOSE, 1/4 X 69 AIR
13	1	601707	HOSE, 1/4 X 63 AIR
14	1	611306	12-P919J-12FJX-12FJX90-42
15	1	611307	10-P919J-10FJX-10FJX-40
16	1	601671	HOSE, 1/4 X 145 AIR
17	1	611352	04-213-04FJX-04FJX-25 H/A

NOTICE

The following page contains decals for the model STS 14.

These decals can be obtained from Hagie Mfg. Co. and should be used whenever your machine is repainted or when the decals become worn, weathered, or faded.

Special attention should be paid to decals involving personal safety. They have been attached for your protection.

KEEP THEM IN PLACE.

**Contact: Hagie Manufacturing Co.
721 Central Ave West
Box 273
Clarion, Iowa 50525-0273**

QTY.	PART NO.	DESCRIPTION	LOCATION
4	650103	TREAD ADJUST INDICATOR DECAL	1-ON EACH LEG SLIDE TUBE
1	650107	CAUTION BOOSTER DECAL	NEAR BOOSTER POSTS
1	650114	FILL WITH FRESH WATER DECAL	ON FRESH WATER TANK
1	650115	HAND WASH ONLY DECAL	NEAR HAND WASH VALVE
1	650116	INDUCTOR FILL INSTRUCTION DECAL	ON SIDE OF FILL ARM
1	650118	DO NOT USE EITHER DECAL	NEAR AIR INTAKE ON SHEET METAL
1	650125	AGITATOR RATE IND DECAL	ON KZCO AGITATION VALVE
1	650132	CUMMINS POWER DECAL	LOCATED ON ENGINE HOOD
1	650140	ENGINE COMPARTMENT DECAL SET	ON ENGINE HOOD
2	650144	LOGO, SOLUTION TANK DECAL	ON EACH SIDE SOLUTION TANK
1	650146	HAGIE UPFRONT DECAL	ON LOWER FRONT WINDSHIELD
1	650154	PATENTS,HAGIE UPFRONT DECAL	ON LOWER LEFT REAR OF MAINFRAME
1	650155	SIDE FILL CONTROL DECAL	ON SIDE FILL SWITCH BOX
1	650156	PRESS WASH CONTROL DECAL	ON PRESS WASHER SWITCH BOX
1	650158	SPEED CONTROL STS CAB DECAL	ON CONSOLE
1	650163	POWER POINT DECAL	ON CONSOLE
1	650164	NO PASSNGR/NOT NEAR LEAK DECAL	ON LEFT UPPER REAR POST
1	650165	PMR LINE/BM FOLD/GLASS DECAL	ON RIGHT REAR UPPER CAB POST
1	650174	RADIATOR CAUTION DECAL	ON TOP OF RADIATOR
1	650176	CAUTION, CAB CHEM EXPOSER DECAL	ON UPPER RIGHT SIDE WINDOW
1	650177	THROTTLE, BRAKE, PUMP DECAL	ON CONSOLE
2	650178	CAUTION QUICK ATTACK PIN DECAL	1-EA ON FRONT CROSSMEMBER BY Q-ATTACH
1	650217	CAUTION, CHECK OIL DECAL	ON PRESSURE WASHER MOUNT
1	650223	30MPH ID SYMBOL DECAL	ON REAR BUMPER
1	650225	SPRAY SELECT STS DECAL	ON CONSOLE
1	650228	BOOM MODULE PINOUT DECAL	INSIDE ELECT LIFT ARM COVER
1	650230	CAB MODULE PINOUT DECAL	IN CONSOLE
1	650231	AUX POWER DECAL	ON THE BOTTOM OF CONSOLE
1	650232	AUX POWER LOCATION DECAL	ON CONSOLE
1	650233	TREAD PINOUT DECAL	ON BELLY PAN
1	650234	ENGINE ELECTRICAL BOX DECAL	INSIDE ENGINE ELECTRICAL BOX
1	650235	REAR MODULE PINOUTS DECAL	INSIDE REAR ELECTRICAL BOX
1	650239	LIGHT/FLASH-FUSE/RELAY DECAL	ON BELLY PAN
1	650264	SIGHT GAUGE, 1400G SS DECAL	ON LEFT REAR OF CAB
1	650272	200AMP ECM FUSE DECAL	NEAR AIR CLEANER MOUNT
1	650275	CONTROL CENTER DECAL	ON CONSOLE
1	650276	FUSE & RELAY DECAL	ON CONSOLE
2	650339	WARNING, HYD OIL INJ DECAL	1-ON SIDE OF OIL TANK
1	650348	NOTICE DRAIN AIR TANK DECAL	ON AIR TANK
1	650367	AIR FILTER INSTRUCTION DECAL	ON ENGINE AIR FILTER END CAP
1	650372	MAIN ELECTRICAL DISCONNECT DECAL	NEAR BOOSTER POSTS
1	650377	NOTICE-R134A 3LB DECAL	1-NEAR ELECTRIC VALVE ON TRANSOM RH SIDE OF ENGINE ON FRAME
1	650848	CAUTION, SLIP OR FALL DECAL	ON LADDER PIVOT TUBE
1	650849	CAUTION, ENGINE FUEL DECAL	NEAR FUEL TANK NECK
1	650850	DANGEROUS CHEM DECAL	SOLUTION TANK FILLER NECK
1	650851	SHIELDS DECAL	ON LOWER LH REAR MAINFRAME TUBE
1	650954	DIESEL DECAL	NEAR FUEL TANK NECK
1	650981	COOLING SYSTEM DECAL	NEAR RADIATOR CAP.
1	650982	ELECTRICAL DECAL	ON RH CAB DOOR
4	650985	WHEEL BOLT TORQUE DECAL	ON EACH WHEEL RIM

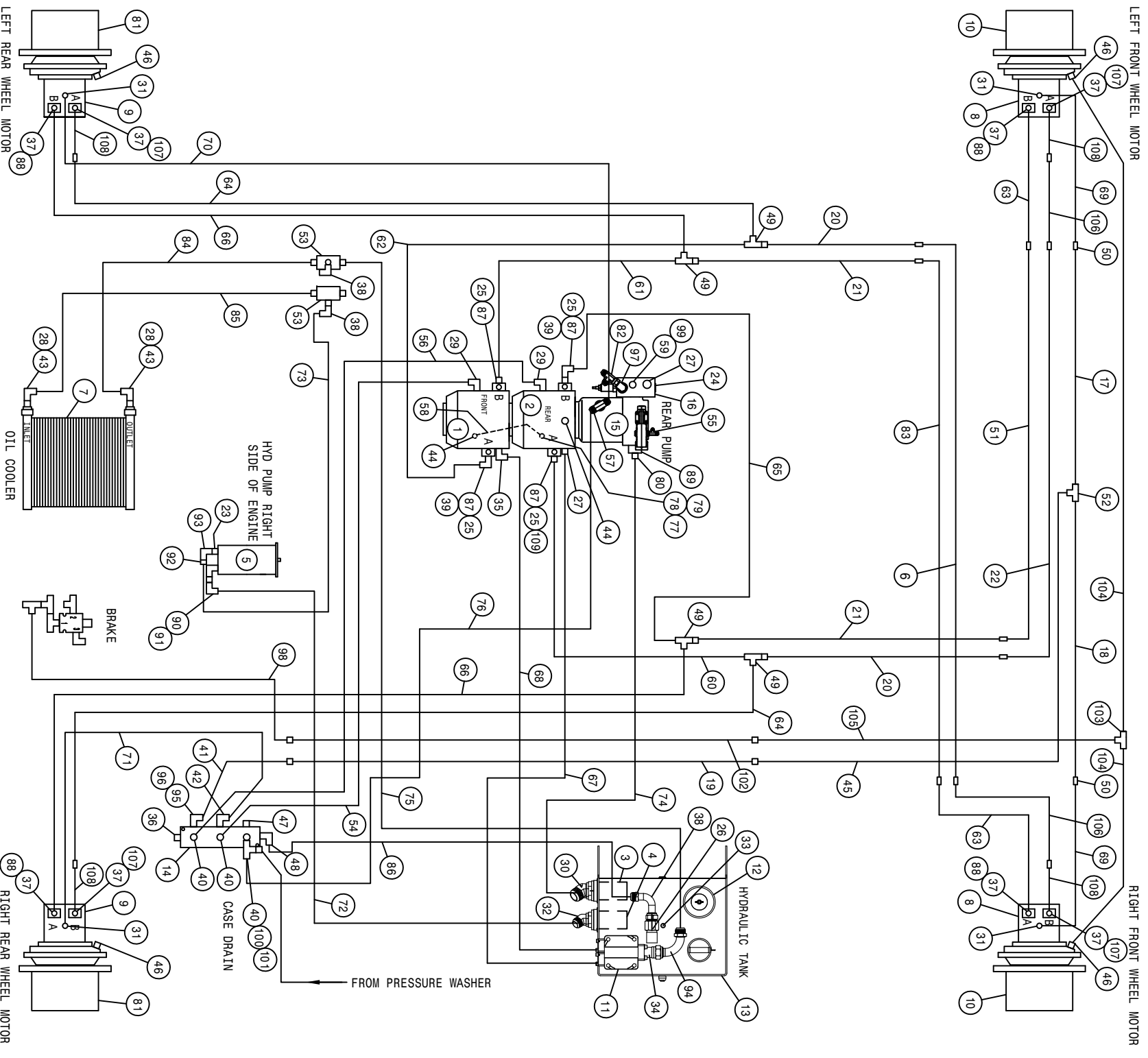

STS 14 HYDRAULIC DIAGRAM 2011
REFERENCE DRAWING NO. 499100S1

DET.	QTY	PART NO.	DESCRIPTION	DET.	QTY	PART NO.	DESCRIPTION	
1	1	606173	SAUER 75CC PUMP, C/C-MT	05	56	1	616400	12-451TC-12FCX-12FCX90L-24 H/A
2	1	606176	SAUER 75CC PUMP, C/B-MT	05	57	1	618637	7/8MOR BRANCH TEE-7/8MJIC
3	1	605623	SUCTION STRAINER, 39GPM 100M	32	58	1	616038	04-471TC-06FCX-06FCX90-15 H/A
4	1	605622	SUCTION STRAINER, 21GPM 100M	24	59	1	611126	7/8MJIC-7/8MOR ADPTR
5	1	607001	SAUER GEAR PUMP 29CC DEIL	60	60	1	616957	16C15-16FFOX-16FFOX45-28 H/A
6	1	615848	RH FRONT HYDROSTAT TUBE ASSY	61	61	1	616340	16C15-16FFOX-16FFOX-51 H/A
7	1	618800	OIL COOLER STS12 2000	62	62	1	616336	16C15-16FFOX-16FFOXL90-78 H/A
8	2	606288	WHL MOTOR, 51C060 SAUER	63	63	2	616565	16C15-16FFOX-16FFOX-129 H/A
9	2	606291	WHL MOTOR, 51C060 W/SENSR SAUER	64	64	2	616942	16C15-16FFOX-16FFOX-140 H/A
10	2	610968	WHEEL HUB, 26:1 W/BRAKE BONFIG	65	65	1	616335	16C15-16FFOX90-16FFOXL90-32H/A
11	1	605625	IN-TANK RETURN FILTER, 10M	66	66	2	616566	16C15-16FFOX-16FFOX90-151 H/A
12	1	605647	BREATHER-HYD RSRVR	67	67	1	616958	16-881-20FLG-16FCX45-66 H/A
13	1	760732	HYD TANK WLD, STS10/12/14 '10	68	68	1	616345	16-881-16FCX-20FLG-73 H/A
14	1	606246	MANIFOLD, #16 3-STN 180	69	69	2	616264	08-451TC-10FCX-08FCX45-136 H/A
15	1	607004	SAUER PISTON PUMP JRR060B	70	70	1	616373	08-451TC-10FCX-08FCX45-212 H/A
16	1	606258	REFIEF, LS PUMP SAUER	71	71	1	616265	08-451TC-12FCX-08FCX45-175 H/A
17	1	615823	LH FRT CASEDRAIN HYD TUBE ASSY	72	72	1	616346	24-881-24FCX-24FCX90-103 H/A
18	1	615822	RH FRT CASEDRAIN HYD TUBE ASSY	73	73	1	616347	16-881-20FCX-16FCX90-59 H/A
19	1	615869	M/F CASE DRAIN TUBE, STS 07	74	74	1	616345	32-881-32FCX-32FCX-53 H/A
20	2	615845	OUTER HYDROSTAT TUBE ASSY	75	75	1	616399	24-881-20FCX-24FCX90-105 H/A
21	2	615888	INNER HYDST TUBE ASSY, 14/20 09	76	76	1	616310	10-451TC-10FCX-12FCX-24 H/A
22	1	615849	LH FRONT HYDROSTAT TUBE ASSY	77	77	1	618734	9/16JIC .047 ORIFICE ADPTR
23	1	611127	1 1/16MJIC-1 1/16MOR ADPTR	78	78	1	618444	9/16MOR RUN TEE-9/16MJIC
24	1	618753	7/16MOR PLUG, HEX SOCKET	79	79	1	618531	9/16FCJIC CAP NUT
25	4	606196	PRESSURE TRANSDUCER, 9000 PSI	80	80	1	618765	2" FLANGE-2 1/2MJIC ADPTR #61
26	1	618767	1 7/8FCJIC-1 5/8MJIC ADPTR	81	81	2	610971	WHEEL HUB, 30:1 W/BRAKE BONFIG
27	2	618186	1 5/16MJIC-1 5/16MOR ADPTR	82	82	1	618451	3/4FCJIC SW RUN TEE-3/4MJIC
28	2	618640	1 1/16MJ-90-1 5/16FJ SWIV LBO	83	83	1	615885	RH FRT WHL MAIN TUBE ASSY, STS09
29	2	618248	1 1/16MJIC-90-1 1/16MOR LBO	84	84	1	616398	20-881-16FCX-20FCX-83 H/A
30	1	618746	2 1/2MJIC-45-2 1/2MOR LBO	85	85	1	616397	20-881-16FCX-20FCX-77 H/A
31	4	618469	3/4MJIC-1 1/16MOR ADPTR	86	86	1	616396	20-881-20FCX-20FCX90-70 H/A
32	1	618745	1 7/8MJIC-45-1 7/8MOR LBO	87	87	4	618799	1"FLG-1"ORFS ADPTR W/9/16 PORT
33	1	470471	1 5/16MOR PLUG, MAGNETIC	88	88	4	618812	3/4 FLANGE-1 7/16MFOR ADPTR
34	1	618747	1 1/2 FLANGE-1 7/8MJIC ADPTR	89	89	1	618766	2" SPLIT FLANGE KIT #61
35	1	618178	1 5/16MJIC-90-1 5/16MOR LBO	90	90	1	618476	1 5/8MJIC-90-1 5/16MOR LBO
36	1	618759	1 5/8MOR PLUG, HEX SOCKET	91	91	1	618762	1 5/8FCJIC-1 7/8MJIC ADPTR
37	8	618431	3/4 (-12) SPLIT FLANGE KIT #62	92	92	1	618641	1 1/16FCJIC-1 5/16MJIC ADPTR
38	3	618768	1 5/8MJIC-90-1 5/8FCX TUBE	93	93	1	618763	1 1/16MJIC-90-1 1/16FCX TUBE
39	2	618362	1 7/16MFOR-90-1 7/16FFOR LBO	94	94	1	618764	1 7/8MJIC-90-1 7/8FCX TUBE LBO
40	3	618308	1 1/16MJIC-1 5/16MOR ADPTR	95	95	1	618463	1 5/16MJIC-90-1 5/16MOR XL LBO
41	1	616444	10-451TC-12FCX-12FCX90-48 H/A	96	96	1	618541	1 5/16FCJIC-1 1/16MJIC ADPTR
42	1	618302	1 1/16MJIC-90-1 5/16MOR LBO	97	97	1	618183	3/4MJIC-90-7/8MOR LBO
43	2	618830	1 5/16MJ-1 5/16MOR 6. OLG ADPTR	98	98	1	616375	04-451TC-06FCX-08FCX-68 H/A
44	2	618119	9/16MJIC-90-9/16MOR LBO	99	99	1	618333	7/8FCJIC SW RUN TEE-7/8MJIC
45	1	616388	10-451TC-12FCX-10FCX90-91 H/A	100	100	1	618487	1 1/16FJ SW RUN TEE-1 1/16MJ
46	4	618467	7/16MJIC-7/16MOR ADPTR	101	101	1	618483	1 1/16FCJIC-9/16MJIC ADPTR
47	1	618758	1 5/16 MOR PLUG, HEX SOCKET	102	102	1	615867	FRONT BRAKE TUBE, STS 07
48	1	618477	1 5/8MJIC-90-1 5/8MOR LBO	103	103	1	618019	9/16MJIC UNION TEE
49	4	618655	1 7/16FFOX RUN TEE-1 7/16MFOR	104	104	2	616277	04-451TC-06FCX-04FCX45-180 H/A
50	2	618456	7/8MJIC UNION	105	105	1	616380	04-451TC-08FCX-06FCX90-85 H/A
51	1	615886	LH FRT WHL MAIN TUBE ASSY, STS09	106	106	2	616338	16C15-16FFOX-16FFOX-127 H/A
52	1	618581	7/8MJIC UNION TEE	107	107	4	618740	3/4 FLANGE-90-1 7/16MFOR LBO
53	2	618752	1 5/8MJIC BLKHD RUN TEE	108	108	4	615875	WHEEL MOTOR HYD TUBE ASSY
54	1	616391	12-451TC-12FCX-12FCX90L-21 H/A	109	109	1	618853	1 7/16MFOR-45-1 7/16FFOR ADPTR
55	1	618509	7/16MOR RUN TEE-7/16MJIC					

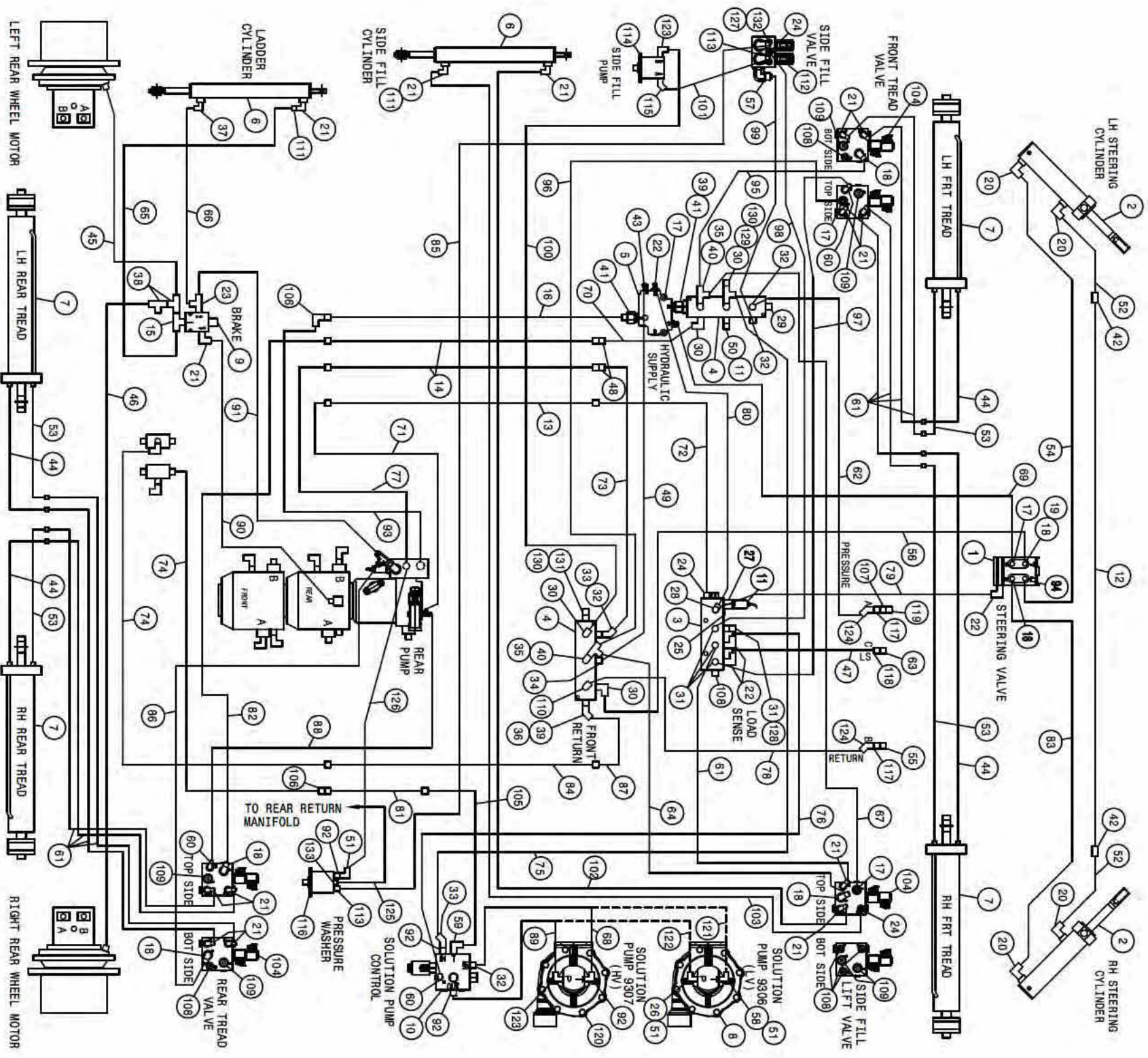

STS 14 HYDRAULIC DIAGRAM 2011
REFERENCE DRAWING NO. 499100S2

DET.	QTY	PART NO.	DESCRIPTION	DET.	QTY	PART NO.	DESCRIPTION
1	1	749331	STEERING CTRL VALVE, LS SAUER	68	1	616477	12-451TC-12FX-12FX-34 H/A
2	2	621550	HYD CYL, 2.50 X 8.81 X 1.250	69	1	616305	06-451TC-08FX-08FX-56 H/A
3	1	606247	MANIFOLD W/CHK VLV SAUER	70	1	616308	10-451TC-10FX-12FX-12 H/A
4	2	606246	MANIFOLD, #16 3-STN 180	71	1	616320	04-451TC-04FX-04FX-47 H/A
5	1	606254	FLOW DIVIDER, OLS160 SAUER	72	1	616435	04-451TC-06FX-04FX45-20 H/A
6	2	621554	HYD CYL, 1.50 X 12.25 X .750	73	1	616310	10-451TC-10FX-12FX-24 H/A
7	4	621552	HYD CYL, 3.00 X 16.00 X 1.375	74	2	616341	16-881-16FX-20FX-51 H/A
8	1	691160	HYPRO PUMP,9306C-PM5C-BU,FLG	75	1	616438	10-451TC-12FX-12FX-87 H/A
9	1	606213	HYD SOLE VLV,2P-3M,9/16FOR 05	76	1	616330	04-451TC-04FX-04FX45-51 H/A
10	1	606253	CTRL VALVE,SOLU PUMP SAUER	77	1	616327	10-451TC-10FX-10FX-44 H/A
11	2	606347	PRESSURE TRANSDUCER,7500PSI	78	1	616405	10-451TC-08FX-12FX-85 H/A
12	1	615772	STRG CYL JUMPER HYD TUBE ASSY	79	1	616379	04-451TC-04FX-04FX-79 H/A
13	1	615866	M/F HYD TUBE, LS LINE, STS 07	80	1	616436	04-451TC-04FX-04FX-21 H/A
14	2	615868	M/F HYD TUBE,PRES,RETNRN STS 07	81	1	615870	HYD RETURN LINE, SHORT
15	1	618629	9/16MOR BRANCH TEE-9/16MJC	82	1	616326	08-451TC-08FX-10FX-48 H/A
16	1	615874	M/F HYD TUBE,MAIN SUPPLY, STS 07	83	1	616730	08-451TC-08FX-08FX-108 H/A
17	4	611125	3/4MJC-3/4MOR ADPTR	84	1	615873	HYD RETURN LINE, LONG
18	6	618241	3/4MJC-90-3/4MOR LBO	85	1	616642	08-451TC-10FX-08FX-204 H/A
19	1	618609	3/4MJC-90-3/4FJIC SWIV LBO	86	1	616307	08-451TC-08FX-08FX-23 H/A
20	4	618249	3/4MJC-90-9/16MOR LBO	87	1	616395	16-881-16FX-16FX-25 H/A
21	14	618119	9/16MJC-90-9/16MOR LBO	88	1	616319	04-451TC-04FX-04FX-32 H/A
22	4	618473	7/16MJC-90-7/16MOR LBO	89	1	616476	10-451TC-10FX-12FX-24 H/A
23	1	618444	9/16MOR RUN TEE-9/16MJC	90	1	616374	04-451TC-06FX-06FX-27 H/A
24	3	618126	9/16MJC-9/16MOR ADPTR	91	1	616364	06-451TC-08FX-06FX-31 H/A
25	1	618753	7/16MOR PLUG, HEX SOCKET	92	4	611127	1 1/16MJC-1 1/16MOR ADPTR
26	1	618108	1 1/16MJC-3/4MNPT ADPTR	93	1	616404	16-451TC-16FX-16FX45-40 H/A
27	1	618361	7/16MOR-9/16FOR ADPTR	94	1	618315	3/4MJC-45-3/4MOR LBO
28	1	618509	7/16MOR RUN TEE-7/16MJC	95	1	616322	06-451TC-08FX-08FX-21 H/A
29	1	618759	1 5/8MOR PLUG, HEX SOCKET	96	1	616443	08-451TC-08FX-08FX-76 H/A
30	4	618302	1 1/16MJC-90-1 5/16MOR LBO	97	1	616315	04-451TC-04FX-04FX45-74 H/A
31	4	618467	7/16MJC-7/16MOR ADPTR	98	1	616437	04-451TC-04FX-06FX-28 H/A
32	4	618308	1 1/16MJC-1 5/16MOR ADPTR	99	1	616416	10-451TC-12FX-12FX-25 H/A
33	2	618529	1 1/16MJC-45-1 1/16FJ SWIV LBO	100	1	616309	10-451TC-10FX-12FX-149 H/A
34	2	618470	3/4MJC-1 5/16MOR ADPTR	101	1	616321	06-451TC-08FX-08FX-136 H/A
35	2	618451	3/4FJIC SW RUN TEE-3/4MJC	102	1	616414	04-451TC-06FX-06FX-126 H/A
36	1	618630	1 5/16MJC-45-1 5/16FJ SWIV LBO	103	1	616415	04-451TC-06FX-06FX-142 H/A
37	1	618688	9/16MJC-90-9/16MOR .025 CHK VLV	104	3	606249	MANIFOLD, TRD ADJ PMSYS
38	2	618486	9/16FJIC SW RUN TEE-9/16MJC	105	1	616465	16-881-16FX-16FX-36 H/A
39	2	618455	1 5/16MJC-1 5/8MOR ADPTR	106	2	618640	1 5/16MJC-90-1 5/16FJ SWIV LBO
40	2	618475	3/4MJC-90-1 5/16MOR LBO	107	1	618171	7/8MOR-3/4FOR ADPTR
41	2	618761	1 5/16FX-1 1/16MOR ADPTR	108	4	618754	9/16MOR PLUG, HEX SOCKET
42	2	618314	3/4MJC UNION	109	6	618755	3/4MOR PLUG, HEX SOCKET
43	1	618114	9/16MJC-90-7/16MOR LBO	110	1	618831	1 1/16MJC-45-1 5/16MOR LBO
44	4	616070	04-451TC-04MJBH-06MOR-11.00H/A	111	2	618733	9/16JIC .042 ORIFICE ADPTR
45	1	616072	04-451TC-06FX-04FX45-195 H/A	112	1	606259	DIVERSION VLV, STS LS 07
46	1	616372	04-451TC-06FX-04FX45-222 H/A	113	2	618474	3/4MJC-90-1 1/16MOR LBO
47	1	616446	04-451ST-06FX-04FX-131 H/A	114	1	690760	BANJO PUMP, 3" SIDE FILL STS12
48	2	618628	7/8MJC-45-7/8FJIC SWIV LBO	115	1	618602	3/4MJC-45-7/8MOR LBO
49	1	616382	06-451TC-06FX-08FX-25 H/A	116	1	690672	HMC 320 SPECIAL/MINUS HOSE
50	1	618397	1 5/16MOR-9/16FOR ADPTR	117	2	618770	3/4MJC-3/4MOR BLKHD ADPT
51	3	618191	1 1/16MJC-90-1 1/16FJ SWIV LBO	118	1	618769	HYD CPLR, MALE #12, 7/8FOR
52	2	616531	08-451TC-08FX-08FX-55 H/A	119	1	618806	HYD CPLR, MALE #12, 7/8FOR
53	4	616071	04-451TC-04MJBH-06MOR-13.00H/A	120	1	616732	3/4MJC-90-7/8MOR LBO
54	1	616504	08-451TC-08FX-08FX-98 H/A	121	1	616451	12-451TC-12FX-12FX-34 H/A
55	1	618807	HYD CPLR, FEM #12, 3/4FOR	122	1	616450	10-451TC-12FX-12FX-22 H/A
56	1	616448	10-451ST-08FX-12FX-119 H/A	123	2	611128	7/8MJC-90-7/8MOR LBO
57	1	618248	1 1/16MJC-90-1 1/16MOR LBO	124	2	618590	3/4MJC-45-3/4FJIC SWIV LBO
58	1	618273	1 1/16MJC-1/2MNPT ADPTR	125	1	616617	06-451TC-06FX-06FX-168 H/A
59	1	618178	1 5/16MJC-90-1 5/16MOR LBO	126	1	616732	10-451TC-10FX-12FX-121 H/A
60	3	618499	7/16MJC-90-9/16MOR LBO	127	1	618774	7/8MJC-90-7/8MOR LG LBO
61	9	616301	04-451TC-04FX-06FX-21 H/A	128	1	618363	7/16FJIC CAP NUT
62	1	616447	10-451ST-08FX-12FX-90-44 H/A	129	1	618487	1 1/16FJ SW RUN TEE-1 1/16MJC
63	1	618805	HYD CPLR, FEM #14, 9/16FOR	130	2	618533	1 1/16FJIC CAP NUT
64	1	616306	08-451TC-08FX-08FX-11 H/A	131	1	618842	1 1/16MJC-90-1 5/8MOR LBO
65	1	616377	04-451TC-06FX-06FX-90-44 H/A	132	1	618132	1 1/16MOR-7/8FOR ADPTR
66	1	616088	04-451TC-06FX-06FX-56 H/A	133	1	618440	9/16MJC-90-9/16MOR EX LG LBO
67	1	616441	06-451TC-08FX-08FX-90-40 H/A				

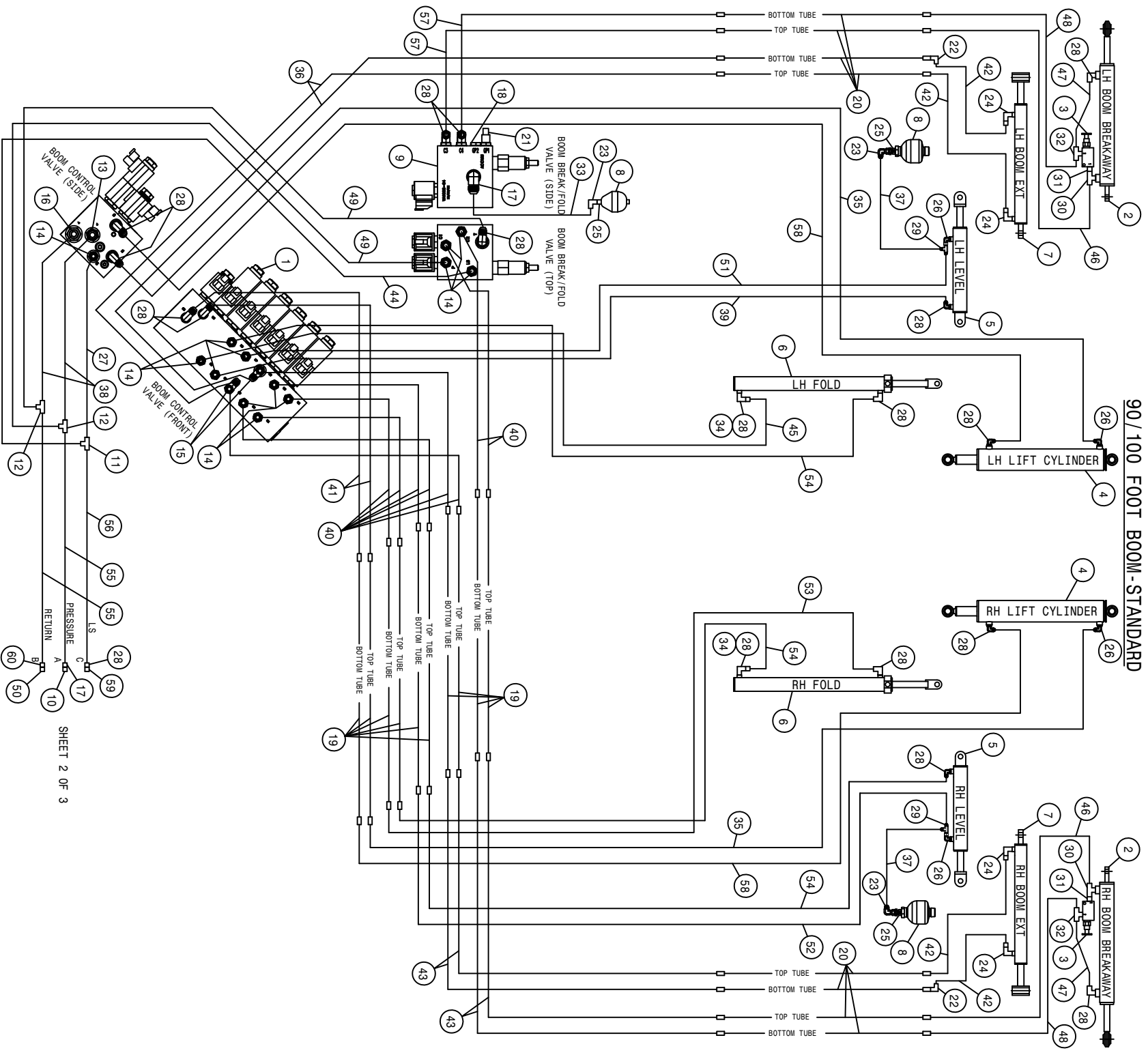

SHEET 2 OF 3

STS 10/12 HYDRAULIC DIAGRAM 2011
REFERENCE DRAWING NO. 49910053

DET.	QTY	PART NO.	DESCRIPTION	DET.	QTY	PART NO.	DESCRIPTION
1	1	606272	VALVE, LOAD SENSE BOOM SAUER	31	2	618668	9/16FJIC SWIV-9/16MOR ADPTR
2	2	621554	HYD CYL, 1.50 X 12.25 X .750	32	2	614752	RESTRICTOR BR TEE ASSY, .042DIA
3	2	607540	KICK-DOWN RELIEF VALVE, 800PSI	33	1	616384	08-451TC-08FJX-08FJX-43 H/A
4	2	621556	HYD CYL, 2.50 X 18.00 X 1.500	34	2	618733	9/16JIC .042 ORIFICE ADPTR
5	2	621558	HYD CYL, 3.00 X 11.00 X 1.380	35	2	616358	06-451TC-06FJX-06FJX-56 H/A
6	2	621560	HYD CYL, 2.50 X 21.00 X 1.380	36	2	616357	06-451TC-06FJX-06FJX90-79 H/A
7	2	621562	HYD CYL, 2.25 X 21.00 X 1.380	37	2	616365	06-451TC-08FJX-06FJX90-30 H/A
8	3	470444	ACCUMULATOR, 30CI 1508 PSI	38	2	616366	08-451TC-08FJX-08FJX90-18 H/A
9	1	606248	90°BREAKAWAY VLV,STS PWRSYS	39	1	616403	06-451TC-06FJX-06FJX-65 H/A
10	1	618807	HYD CPLR, FEM #12,3/4FOR	40	8	616316	06-451TC-06FJX-06FJX45-18 H/A
11	1	618748	7/16MJIC BLKHD RUN TEE	41	2	616304	06-451TC-06FJX-06FJX-36 H/A
12	2	618749	3/4MJIC BLKHD RUN TEE	42	4	616356	06-451TC-06FJX-06FJX90-27 H/A
13	1	611125	3/4MJIC-3/4MOR ADPTR	43	4	616353	06-451TC-06FJX-06FJX-71 H/A
14	13	618126	9/16MJIC-9/16MOR ADPTR	44	1	616362	04-451TC-04FJX-06FJX90-35 H/A
15	2	618444	9/16MOR RUN TEE-9/16MJIC	45	1	616352	06-451TC-06FJX-06FJX-62 H/A
16	1	618327	3/4MJIC-7/8MOR ADPTR	46	2	616360	06-451TC-06FJX-06FJX-84 H/A
17	2	618241	3/4MJIC-90-3/4MOR LBO	47	2	616075	04-451TC-06FJX-06FJX-9 H/A
18	1	618754	9/16MOR PLUG, HEX SOCKET	48	2	616361	06-451TC-06FJX-06FJX-86 H/A
19	10	615852	LIFTARM HYD TUBE ASSY, STSLS 07	49	2	616364	06-451TC-08FJX-06FJX90-31 H/A
20	8	615851	HYD TUBE,MAIN BOOM,STS	50	1	618806	HYD CPLR,MALE #12,7/8FOR
21	1	606347	PRESSURE TRANSDUCER,7500PSI	51	1	616349	06-451TC-06FJX-06FJX-47 H/A
22	2	618618	9/16MJIC-90-9/16FJIC SWIV LBO	52	1	616348	06-451TC-06FJX-06FJX-42 H/A
23	3	618609	3/4MJIC-90-3/4FJIC SWIV LBO	53	1	616350	06-451TC-06FJX-06FJX-58 H/A
24	4	618688	9/16MJ-90-9/16MOR .025 CHK VLV	54	3	616351	06-451TC-06FJX-06FJX-60 H/A
25	3	618743	3/4MOR-3/4MJIC BLKHD, .040 ORF	55	2	616135	08-451TC-08FJX-08FJX-50 H/A
26	4	618689	9/16MJ-90-9/16MOR .042 CHK VLV	56	1	616431	04-451TC-04FJX-06FJX-51 H/A
27	1	616430	04-451TC-06FJX-04FJX90-19 H/A	57	2	616359	06-451TC-06FJX-06FJX-78 H/A
28	18	618119	9/16MJIC-90-9/16MOR LBO	58	4	616371	06-451TC-06FJX-06FJX-38 H/A
29	2	618486	9/16FJIC SW RUN TEE-9/16MJIC	59	1	618804	HYD CPLR,MALE #14,9/16FOR
30	2	618629	9/16MOR BRANCH TEE-9/16MJIC	60	1	618183	3/4MJIC-90-7/8MOR LBO

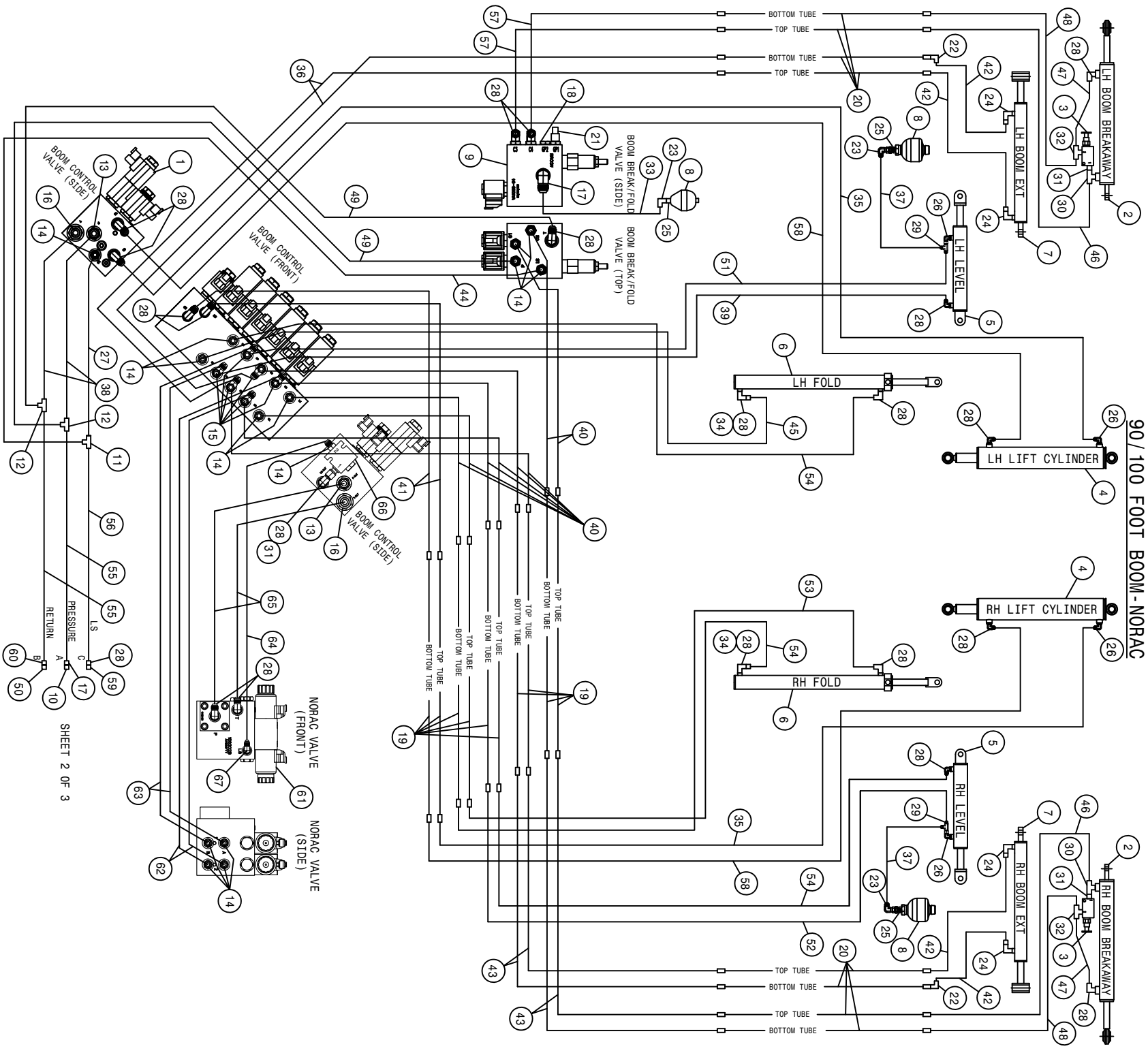

SHEET 2 OF 3

STS 14 HYDRAULIC DIAGRAM 2011
REFERENCE DRAWING NO. 499100S4

DET.	QTY	PART NO.	DESCRIPTION	DET.	QTY	PART NO.	DESCRIPTION
1	1	606272	VALVE, LOAD SENSE BOOM SAUER	35	2	616358	06-451TC-06FJX-06FJX-56
2	2	621554	HYD CYL, 1.50 X 12.25 X .750	36	2	616357	06-451TC-06FJX-06FJX90-79
3	2	607540	KICK-DOWN RELIEF VALVE, 800PSI	37	2	616365	06-451TC-08FJX-06FJX90-30
4	2	621556	HYD CYL, 2.50 X 18.00 X 1.500	38	2	616366	08-451TC-08FJX-08FJX90-18
5	2	621558	HYD CYL, 3.00 X 11.00 X 1.380	39	1	616403	06-451TC-06FJX-06FJX-65
6	2	621560	HYD CYL, 2.50 X 21.00 X 1.380	40	8	616316	06-451TC-06FJX-06FJX45-18
7	2	621562	HYD CYL, 2.25 X 21.00 X 1.380	41	2	616304	06-451TC-06FJX-06FJX-36
8	3	470444	ACCUMULATOR, 30CI 1508 PSI	42	4	616356	06-451TC-06FJX-06FJX90-27
9	1	606248	90°BREAKAWAY VLV,STS PWRSYS	43	4	616353	06-451TC-06FJX-06FJX-71
10	1	618807	HYD CPLR, FEM #12,3/4FOR	44	1	616362	06-451TC-04FJX-06FJX90-35
11	1	618748	7/16MJIC BLKHD RUN TEE	45	1	616352	06-451TC-06FJX-06FJX-62
12	2	618749	3/4MJIC BLKHD RUN TEE	46	2	616360	06-451TC-06FJX-06FJX-84
13	2	611125	3/4MJIC-3/4MOR ADPTR	47	2	616075	04-451TC-06FJX-06FJX-9
14	14	618126	9/16MJIC-9/16MOR ADPTR	48	2	616361	06-451TC-06FJX-06FJX-86
15	6	618444	9/16MOR RUN TEE-9/16MJIC	49	2	616364	06-451TC-08FJX-06FJX90-31
16	2	618327	3/4MJIC-7/8MOR ADPTR	50	1	618806	HYD CPLR, MALE #12, 7/8FOR
17	2	618241	3/4MJIC-90-3/4MOR LBO	51	1	616349	06-451TC-06FJX-06FJX-47
18	1	618754	9/16MOR PLUG, HEX SOCKET	52	1	616348	06-451TC-06FJX-06FJX-42
19	10	615852	LIFTARM HYD TUBE ASSY, STSLS 07	53	1	616350	06-451TC-06FJX-06FJX-58
20	8	615851	HYD TUBE, MAIN BOOM, STS	54	3	616351	06-451TC-06FJX-06FJX-60
21	1	606347	PRESSURE TRANSDUCER, 7500PSI	55	2	616135	08-451TC-08FJX-08FJX-50
22	2	618618	9/16MJIC-90-9/16FJIC SWIV LBO	56	1	616431	04-451TC-04FJX-06FJX-51
23	3	618609	3/4MJIC-90-3/4FJIC SWIV LBO	57	2	616359	06-451TC-06FJX-06FJX-78
24	4	618688	9/16MJ-90-9/16MOR .025 CHK VLV	58	4	616371	06-451TC-06FJX-06FJX-38
25	3	618743	3/4MOR-3/4MJIC BLKHD, .040 ORF	59	1	618804	HYD CPLR, MALE #14, 9/16FOR
26	4	618689	9/16MJ-90-9/16MOR .042 CHK VLV	60	1	618183	3/4MJIC-90-7/8MOR LBO
27	1	616430	04-451TC-06FJX-04FJX90-19 H/A	61	1	606455	NORAC HYD VALVE (449630D)
28	21	618119	9/16MJIC-90-9/16MOR LBO	62	2	616555	06-451TC-06FJX-06FJX90-31 H/A
29	2	618486	9/16FJIC SW RUN TEE-9/16MJIC	63	2	616557	06-451TC-06FJX-06FJX90L-31 H/A
30	2	618629	9/16MOR BRANCH TEE-9/16MJIC	64	1	616554	04-451TC-04FJX-06FJX90-30 H/A
31	3	618668	9/16FJIC SWIV-9/16MOR ADPTR	65	2	616556	08-451TC-06FJX-08FJX90-31 H/A
32	2	614752	RESTRICTOR BR TEE ASSY, .042DIA	66	1	606256	CHECK VALVE, IN LINE SAUER
33	1	616384	08-451TC-08FJX-08FJX-43 H/A	67	1	618473	7/16MJIC-90-7/16MOR LBO
34	2	618733	9/16MJIC .042 ORIFICE ADPTR				

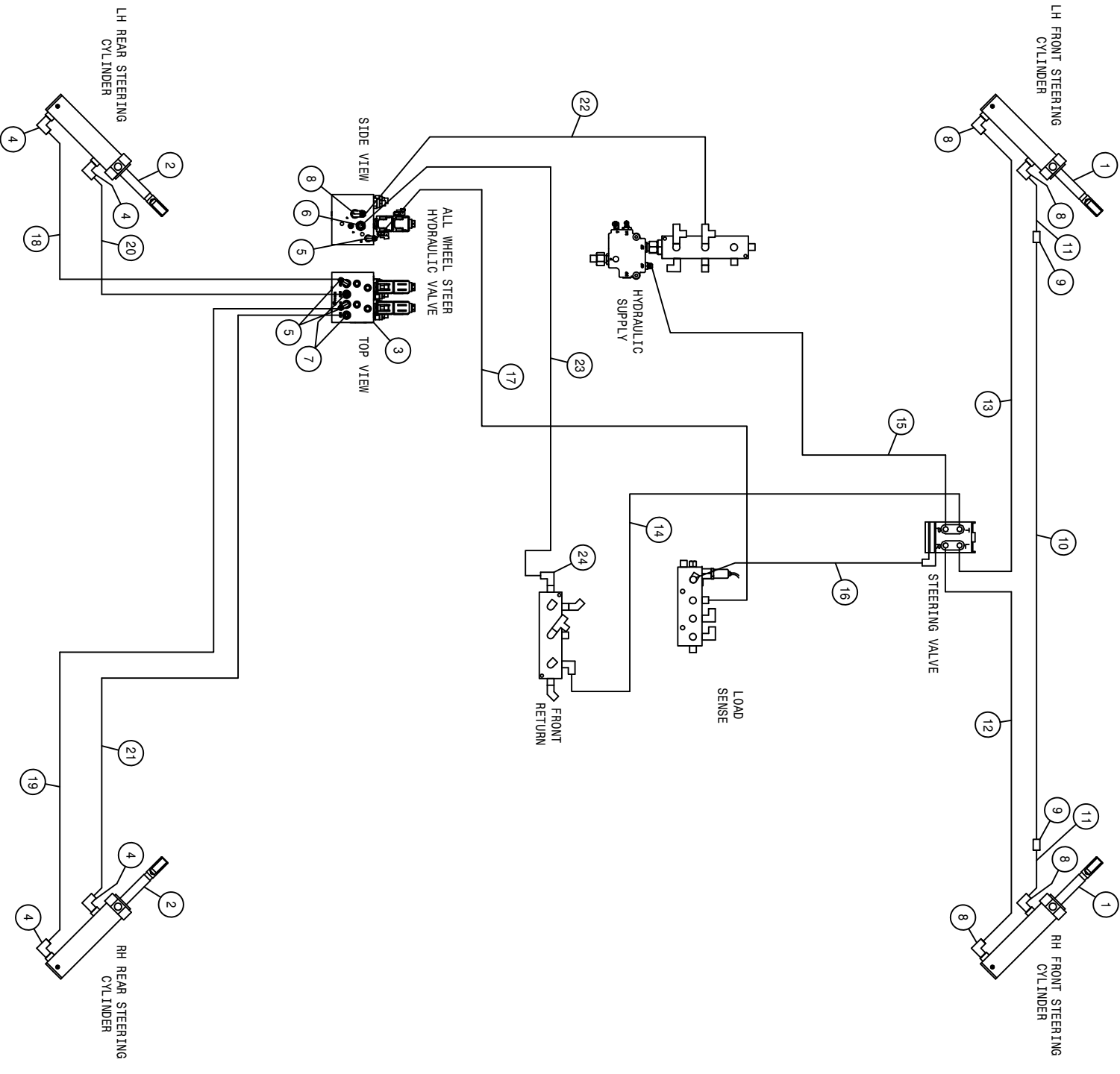

ALL WHEEL STEER DIAGRAM

STS 14 HYDRAULIC DIAGRAM 2011
REFERENCE DRAWING NO. 499100S5

DET.	QTY	PART NO.	DESCRIPTION	DET.	QTY	PART NO.	DESCRIPTION
1	2	621602	HYD CYL, 2.50 X 8.81 PHASE/SENS	13	1	616730	08-451TC-08FJX-08FJX90-108 H/A
2	2	621603	HYD CYL, 2.50 X 8.81 W/SENSOR	14	1	616448	10-451ST-08FJX-12FJX-119 H/A
3	1	606370	VALVE, FV8623 V1 SUNSOURCE	15	1	616305	06-451TC-08FJX-08FJX-56 H/A
4	4	618115	9/16MJIC-90-3/4MOR LBO	16	1	616379	04-451TC-04FJX-04FJX90-79 H/A
5	3	618119	9/16MJIC-90-9/16MOR LBO	17	1	616716	04-451TC-06FJX-04FJX90-119 H/A
6	1	611126	7/8MJIC-7/8MOR ADPTR	18	1	616710	08-451TC-06FJX-06FJX-95 H/A
7	2	618126	9/16MJIC-9/16MOR ADPTR	19	1	616711	08-451TC-06FJX-06FJX-129 H/A
8	5	618241	3/4MJIC-90-3/4MOR LBO	20	1	616712	08-451TC-06FJX-06FJX90-91 H/A
9	2	618314	3/4MJIC UNION	21	1	616713	08-451TC-06FJX-06FJX90-119 H/A
10	1	615772	STRG CYL JUMPER HYD TUBE ASSY	22	1	616717	08-451TC-08FJX-12FJX90-118 H/A
11	1	616531	08-451TC-08FJX-08FJX-55 H/A	23	1	616718	10-451TC-12FJX-10FJX90-108 H/A
12	1	616504	08-451TC-08FJX-08FJX-98 H/A	24	1	618191	1 1/16MJ-90-1 1/16FJ SWIV LBO

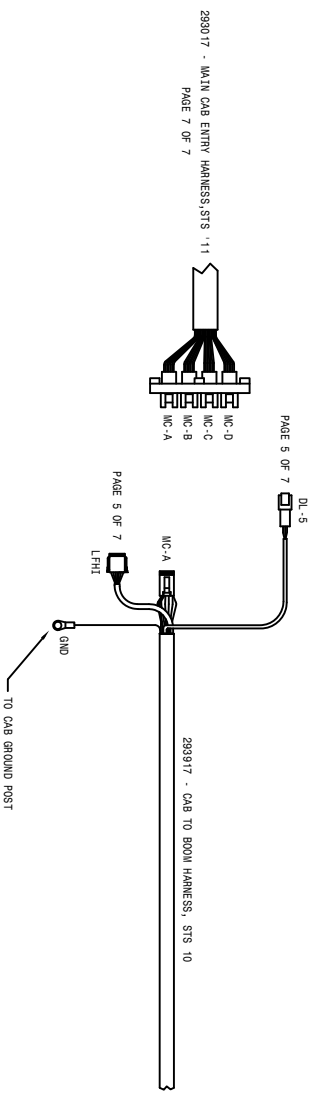
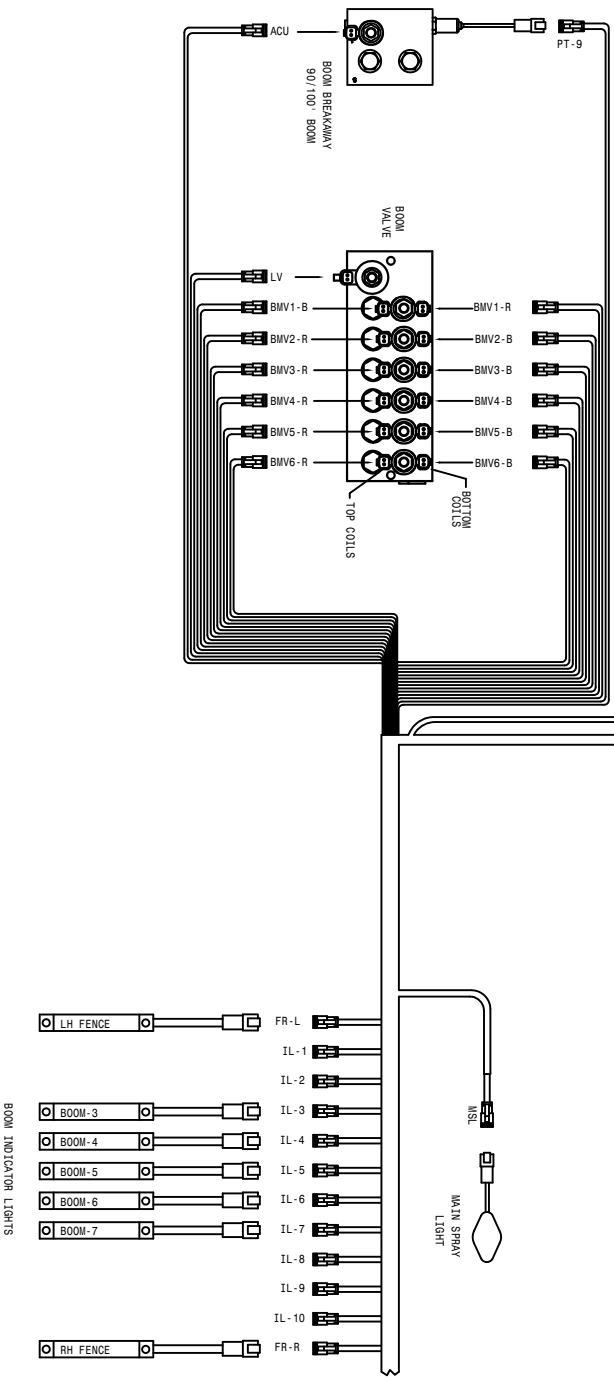
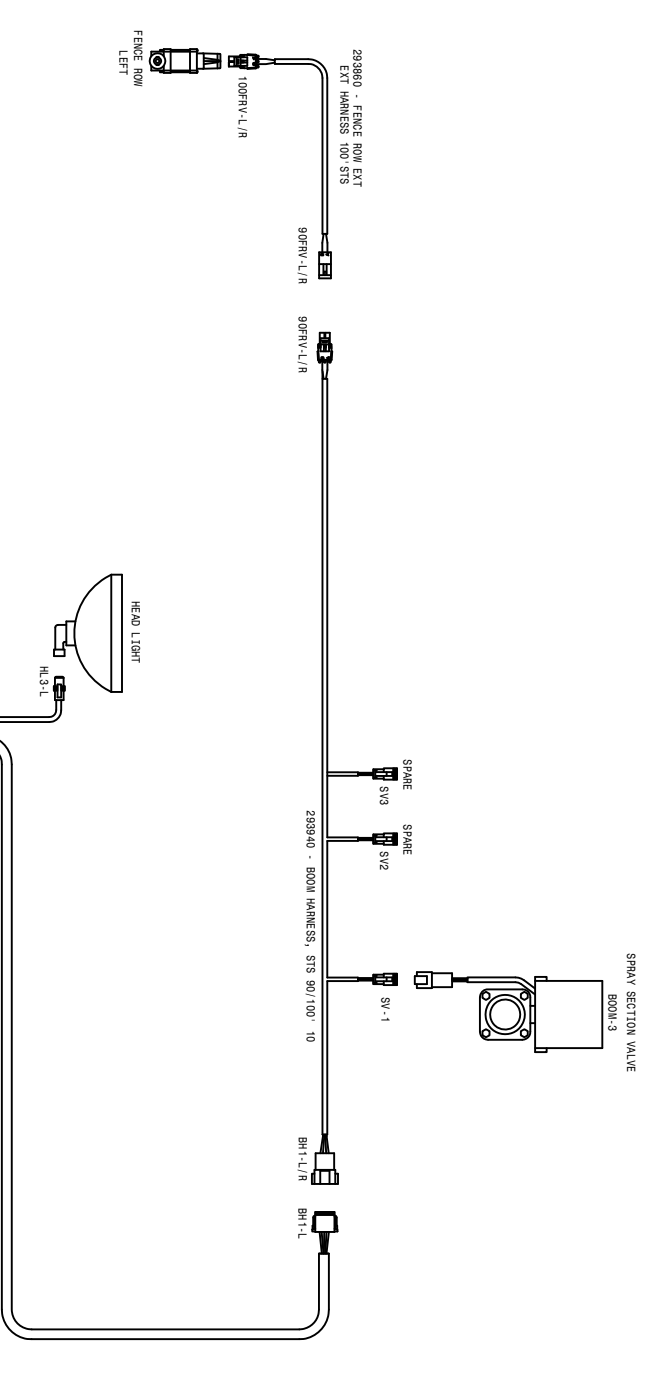

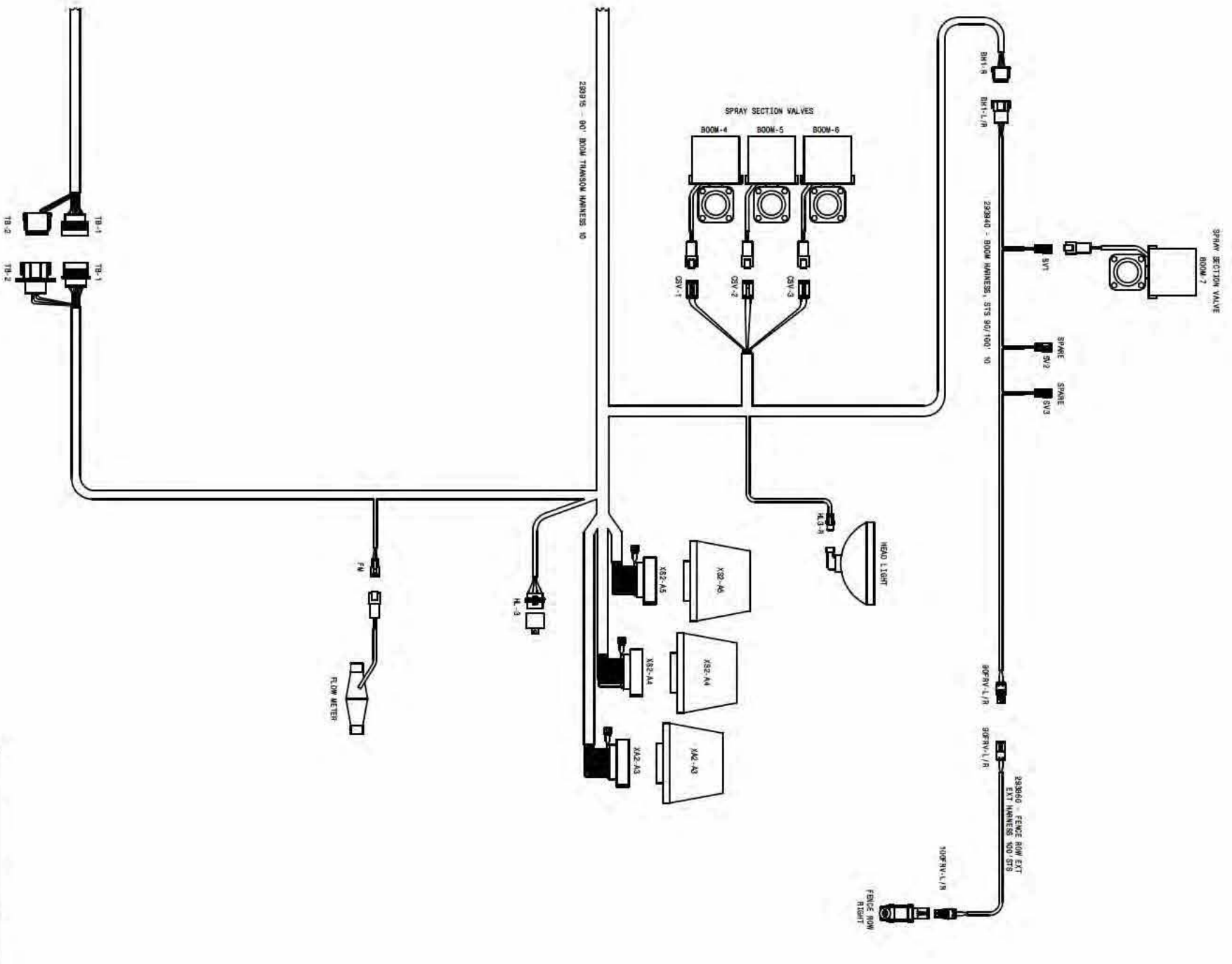

STS 14 WIRING DIAGRAM 11
 90' BOOM
 SHEET 1 OF 2
 REVISION DATE: 06-27-16
 499218

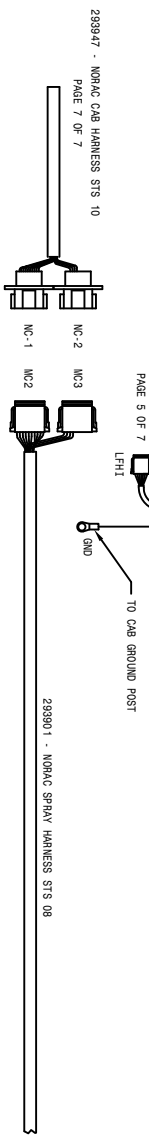
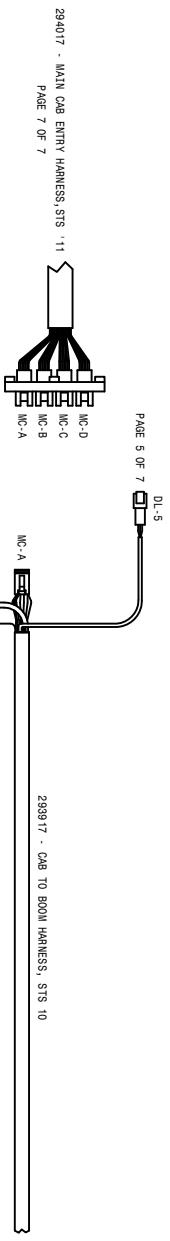
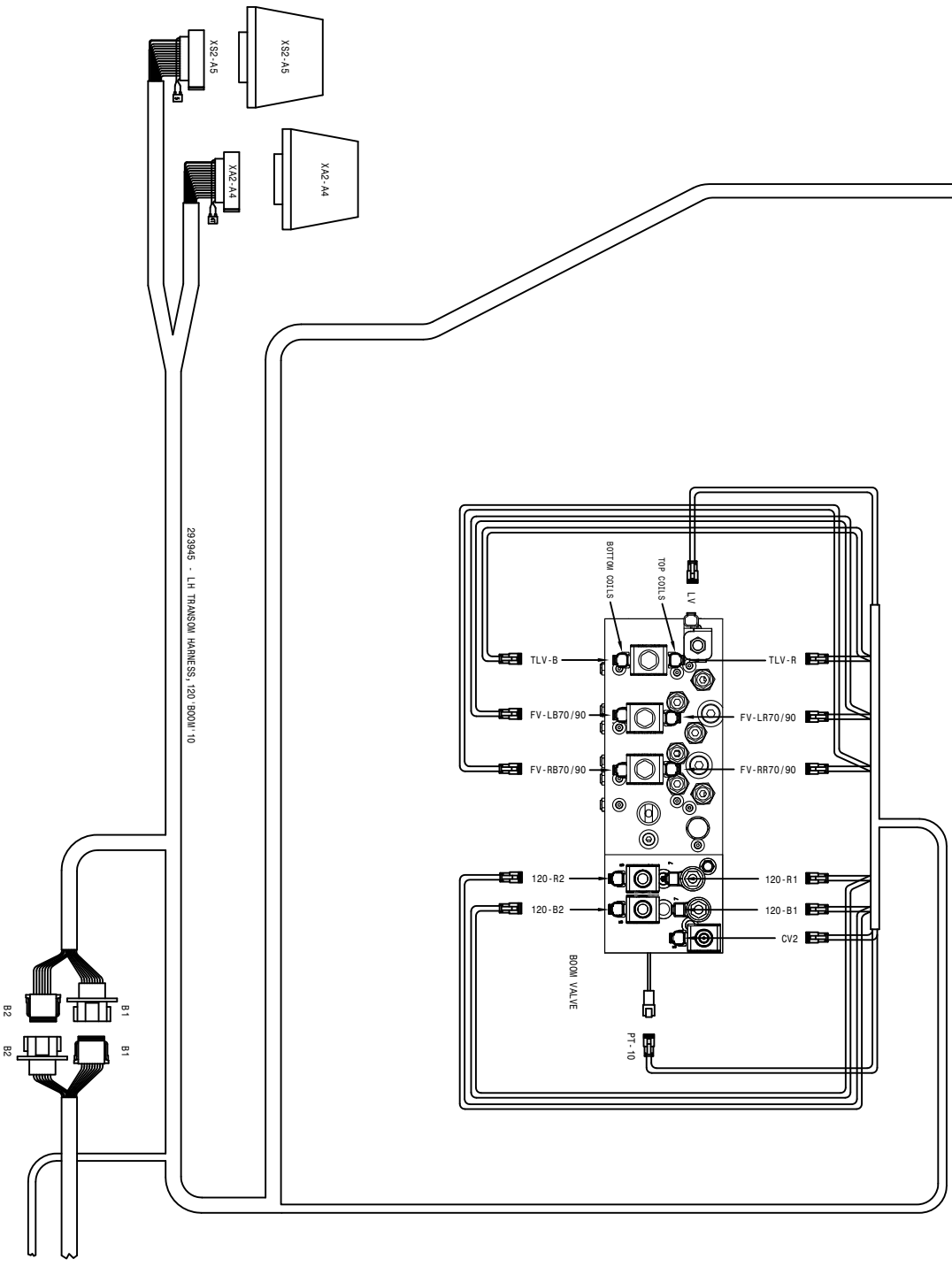

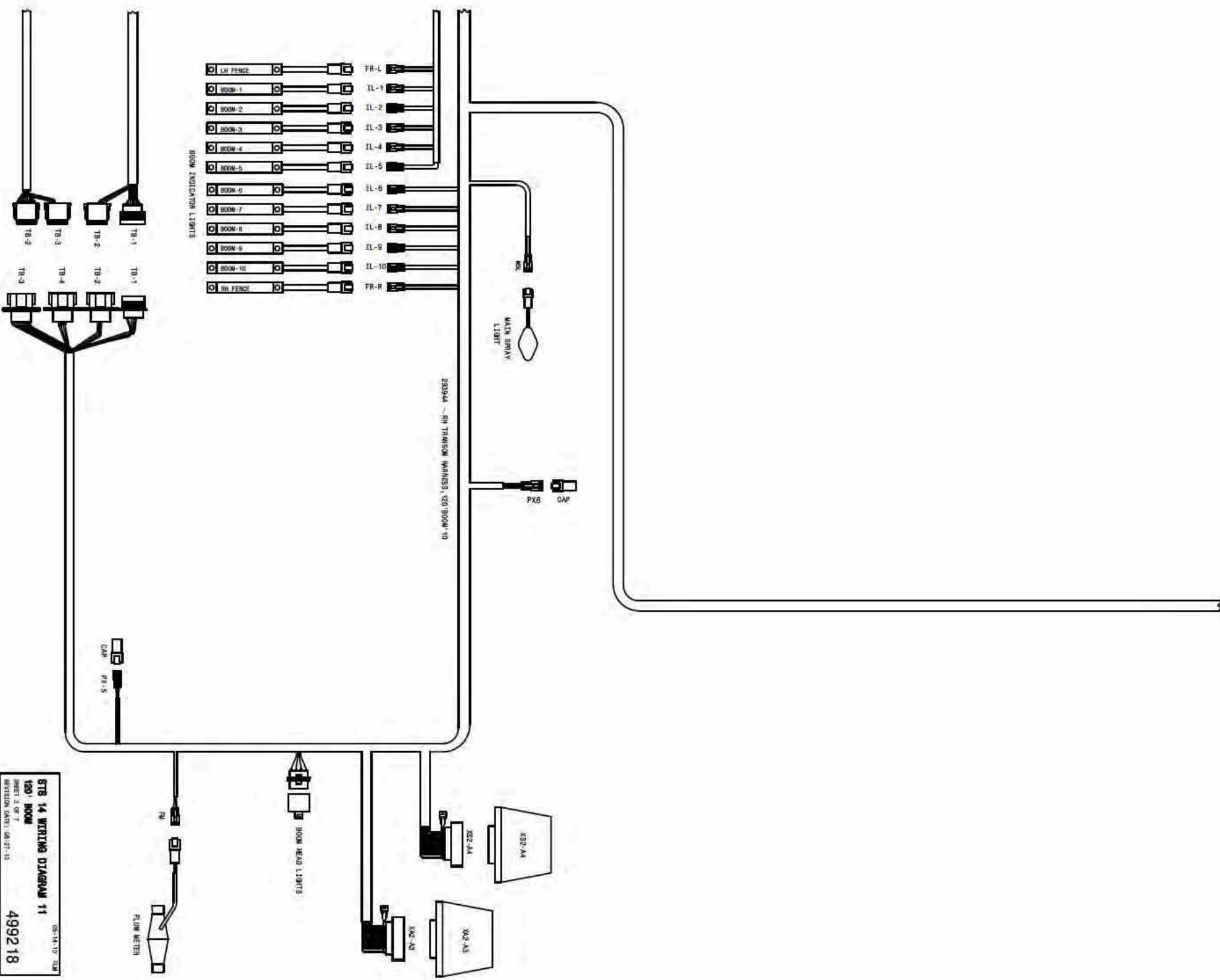

- FR-L
 - IL-1
 - IL-2
 - IL-3
 - IL-4
 - IL-5
 - IL-6
 - IL-7
 - IL-8
 - IL-9
 - IL-10
 - FR-R
- BOOM INDICATION LIGHTS
- LM FENCE
 - BOOM-1
 - BOOM-2
 - BOOM-3
 - BOOM-4
 - BOOM-5
 - BOOM-6
 - BOOM-7
 - BOOM-8
 - BOOM-9
 - BOOM-10
 - RM FENCE

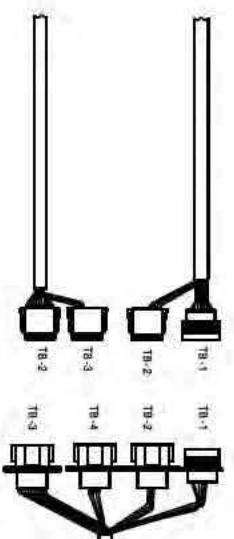

STS 14 WRITING DIAGRAM 11
120' ROOM
SHEET 3 OF 7
REVISION DATE: 06-27-10
499218

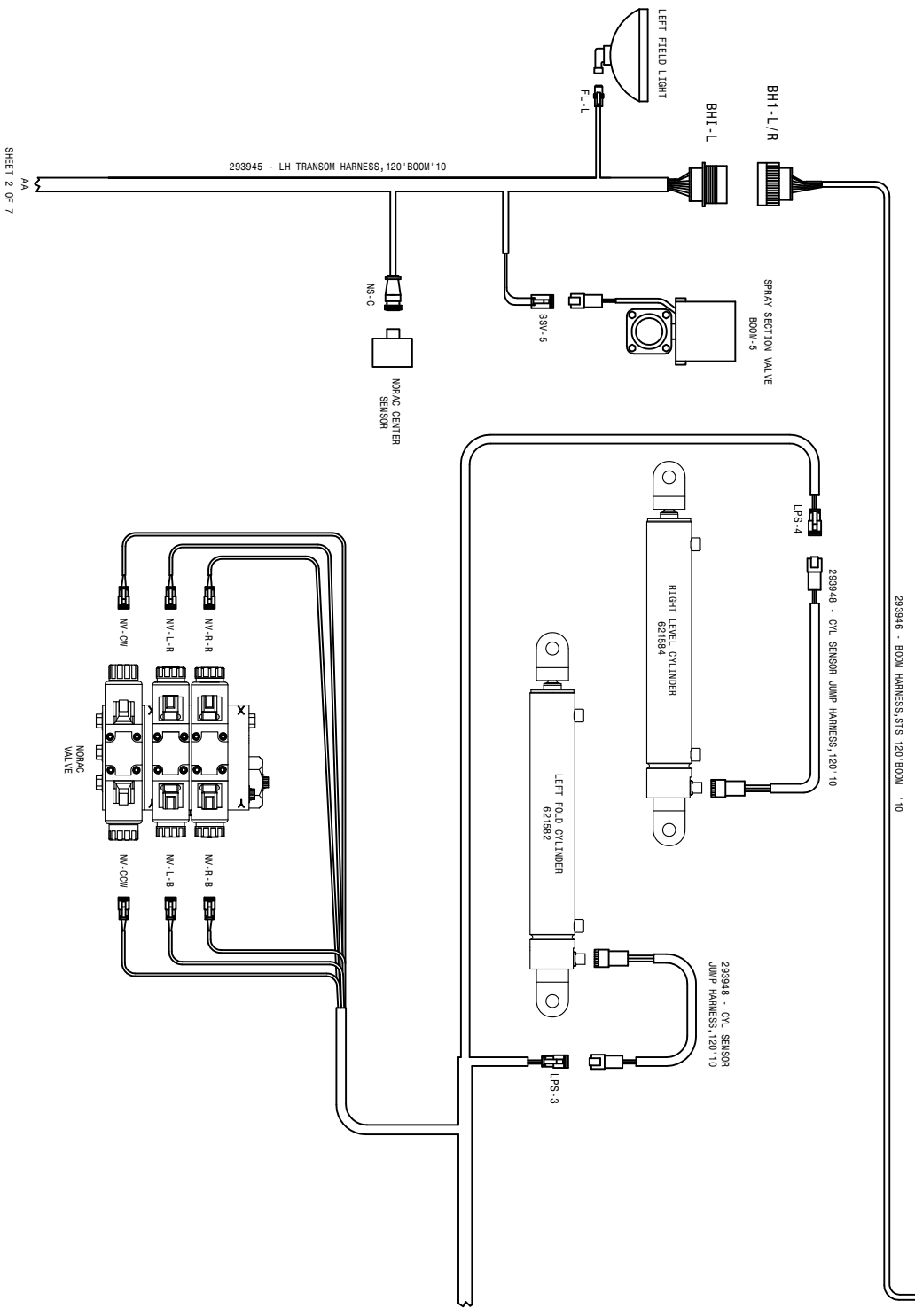
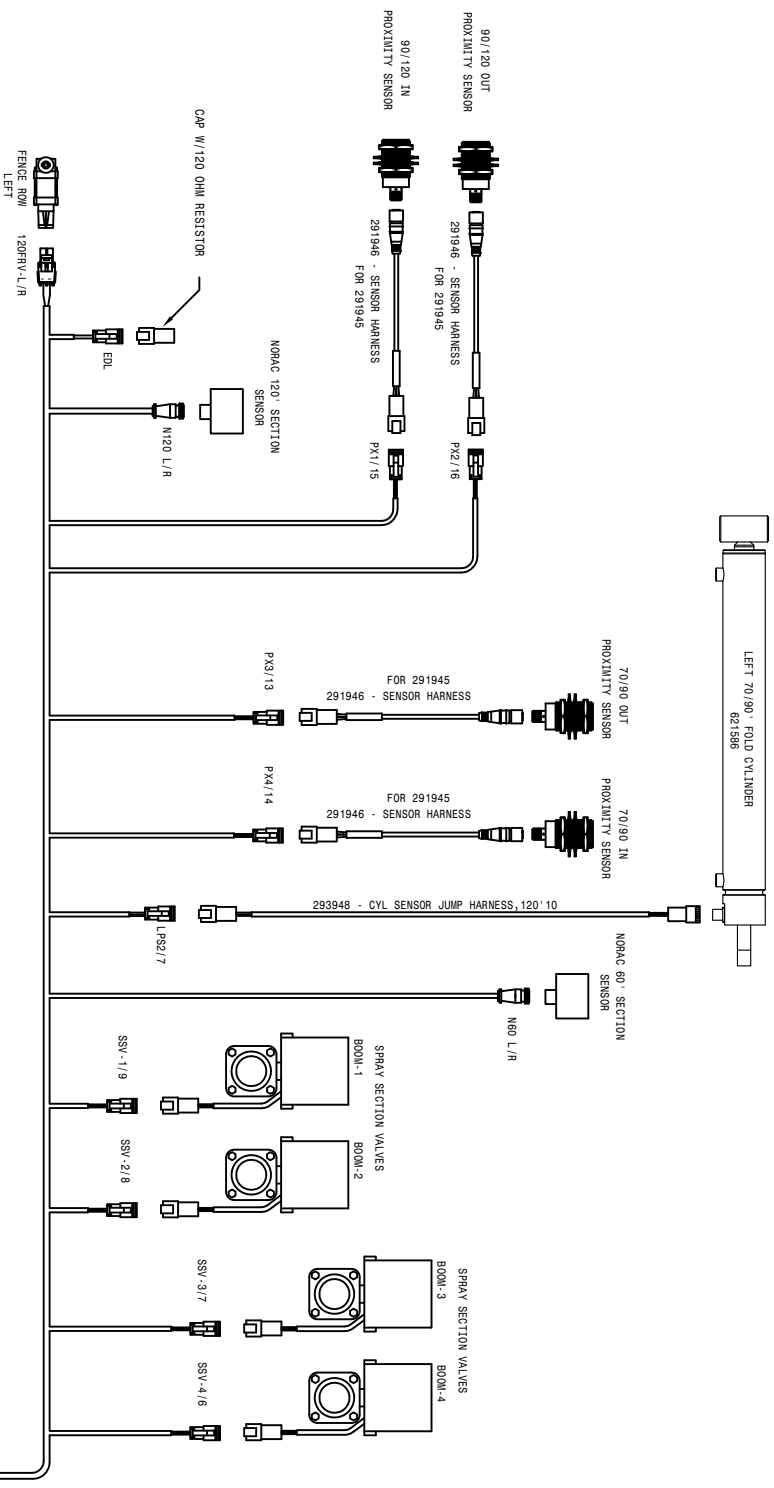

SHEET 2 OF 7

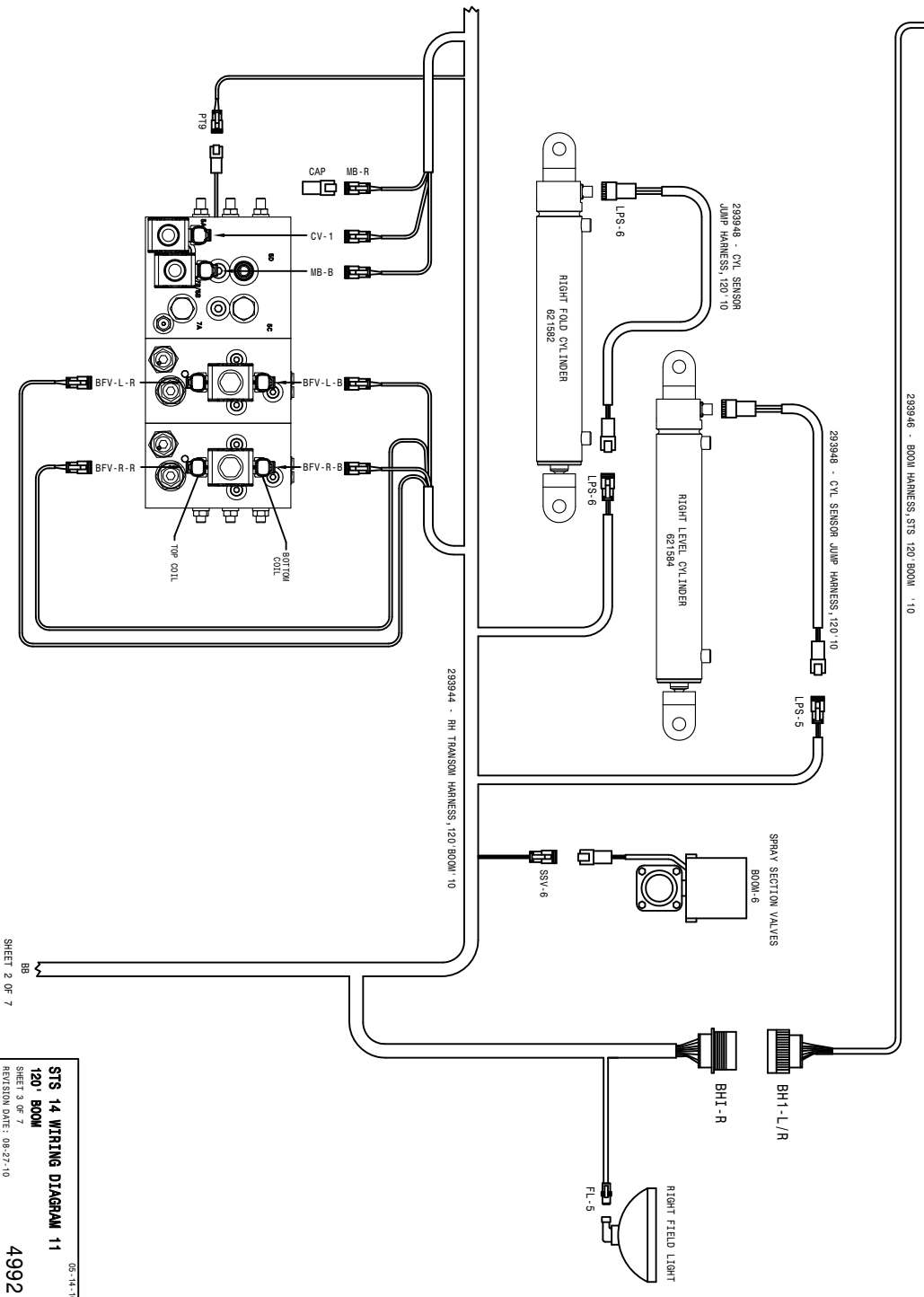
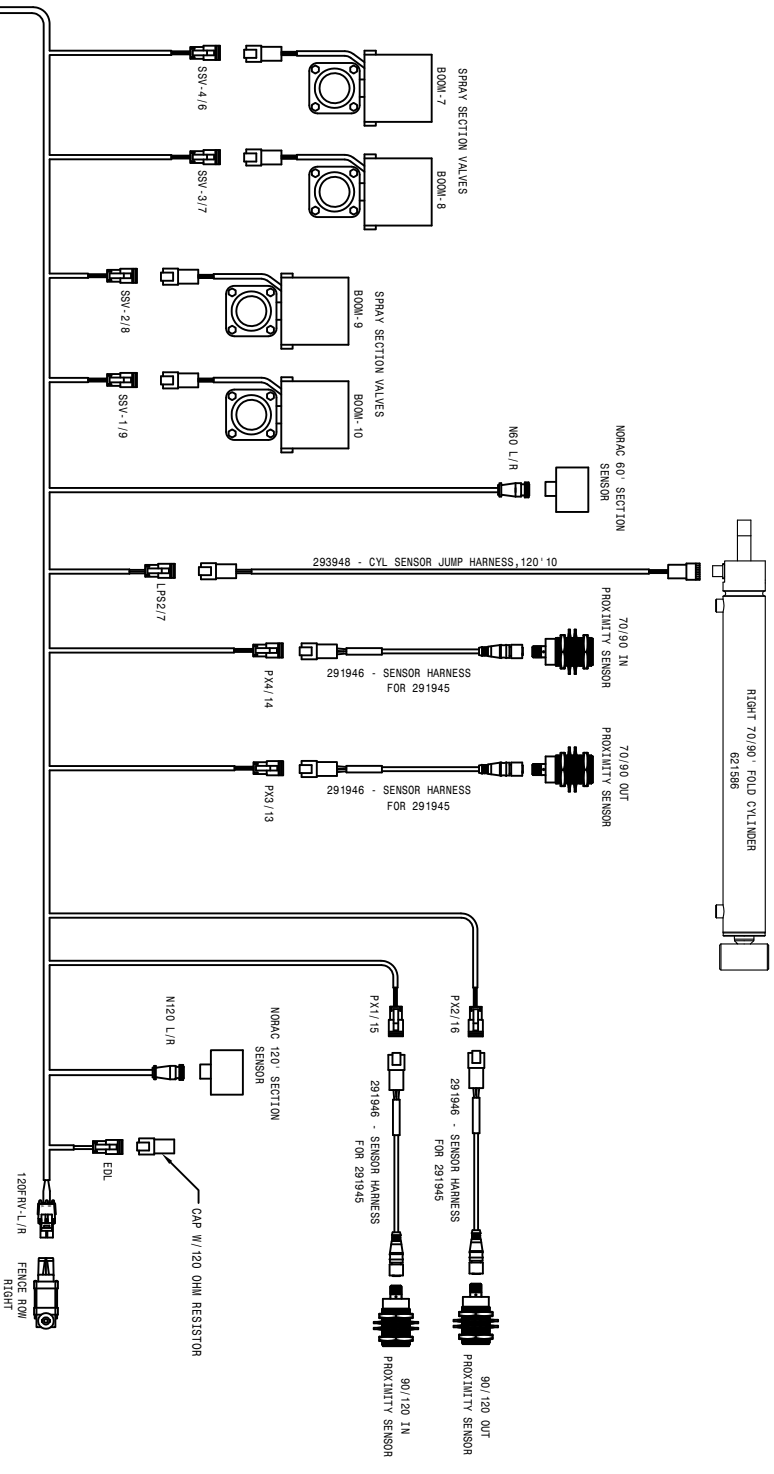

SHEET 2 OF 7
BB

05-14-10 TLM
STS 14 WIRING DIAGRAM 11
120' BOOM
 SHEET 3 OF 7
 REVISION DWE: 08-27-10
499218

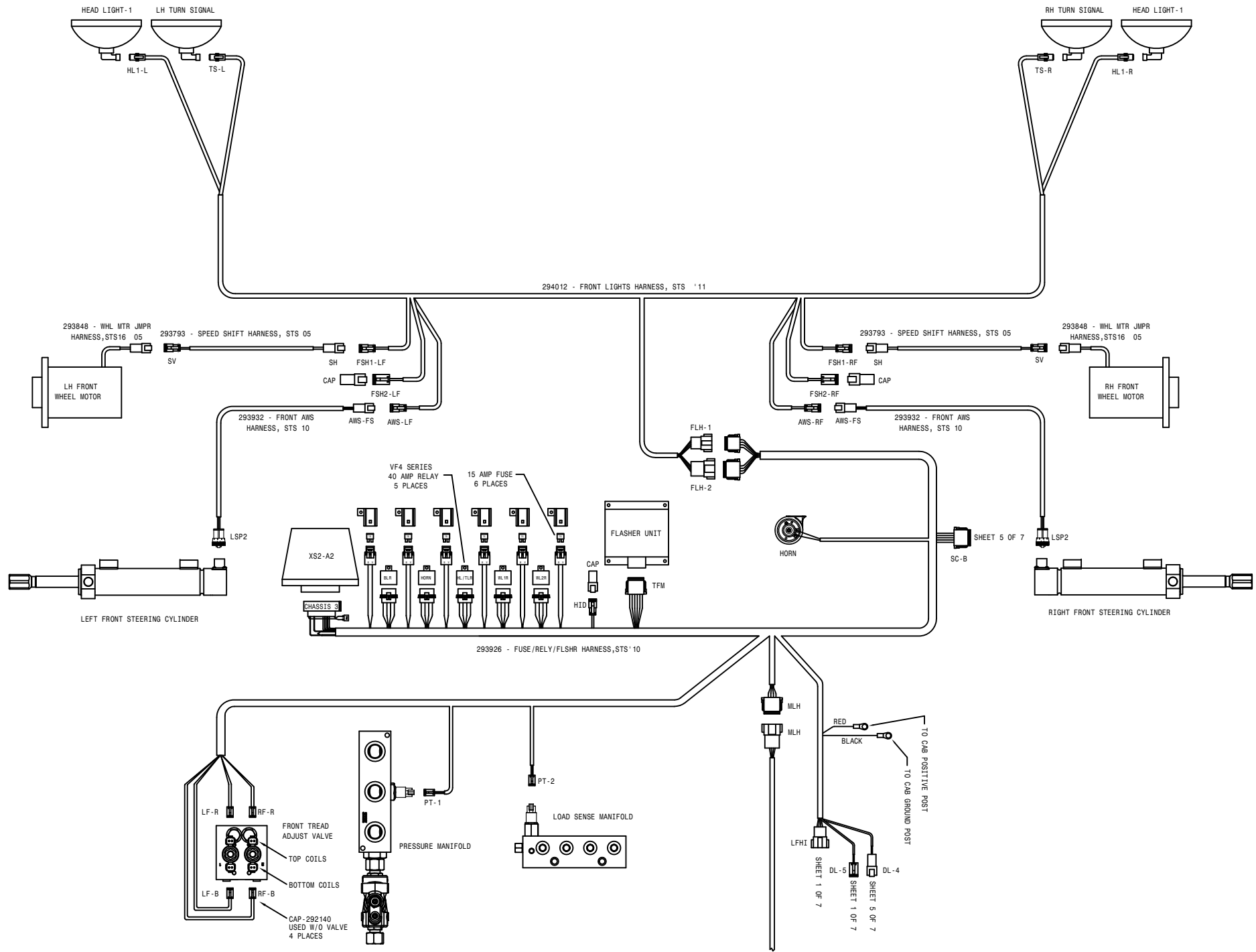

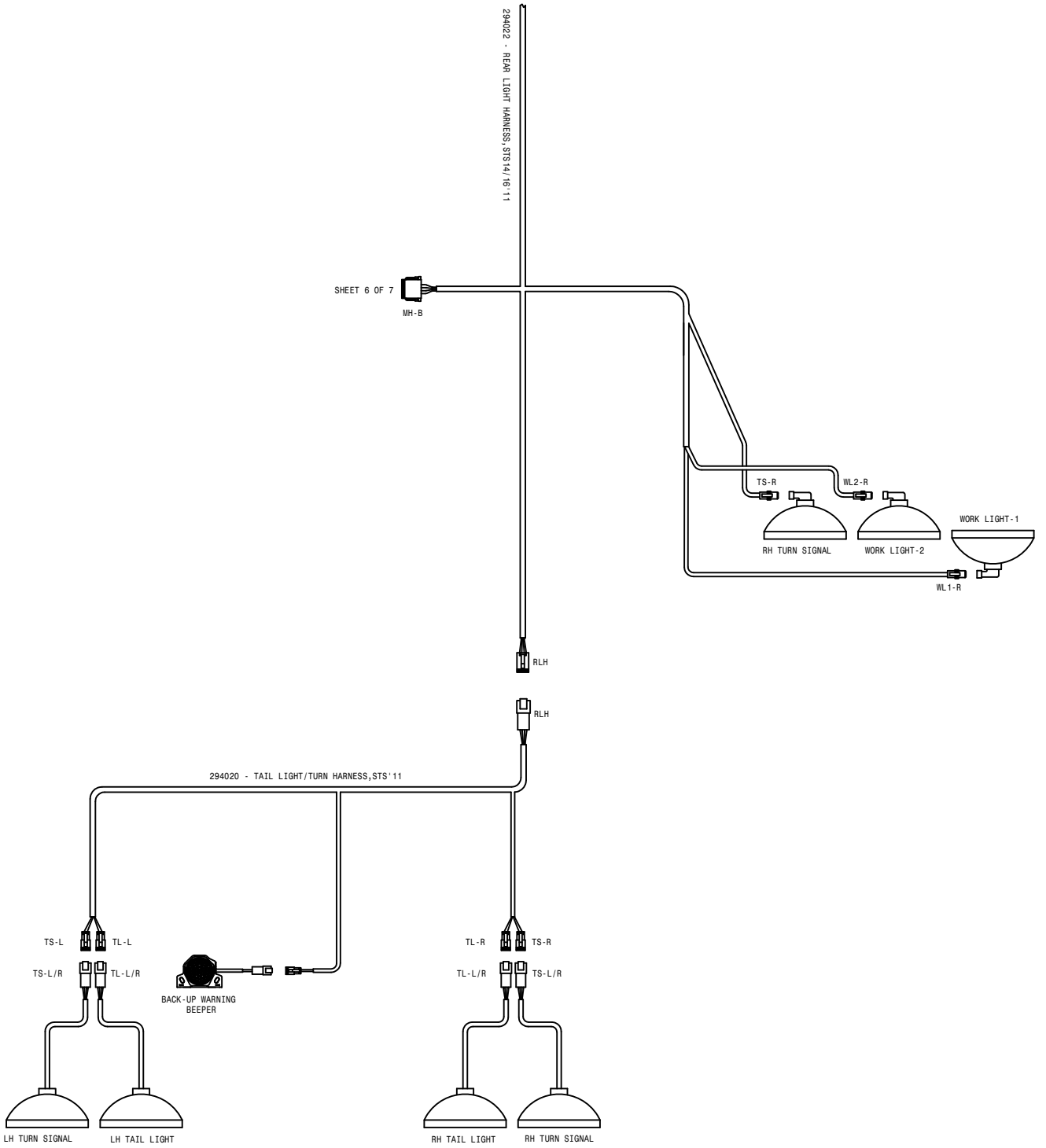

STS 14 WIRING DIAGRAM 11
 SHEET 4 OF 7
 REVISION DATE: 06-27-'10
 05-14-'10 TUM
499218

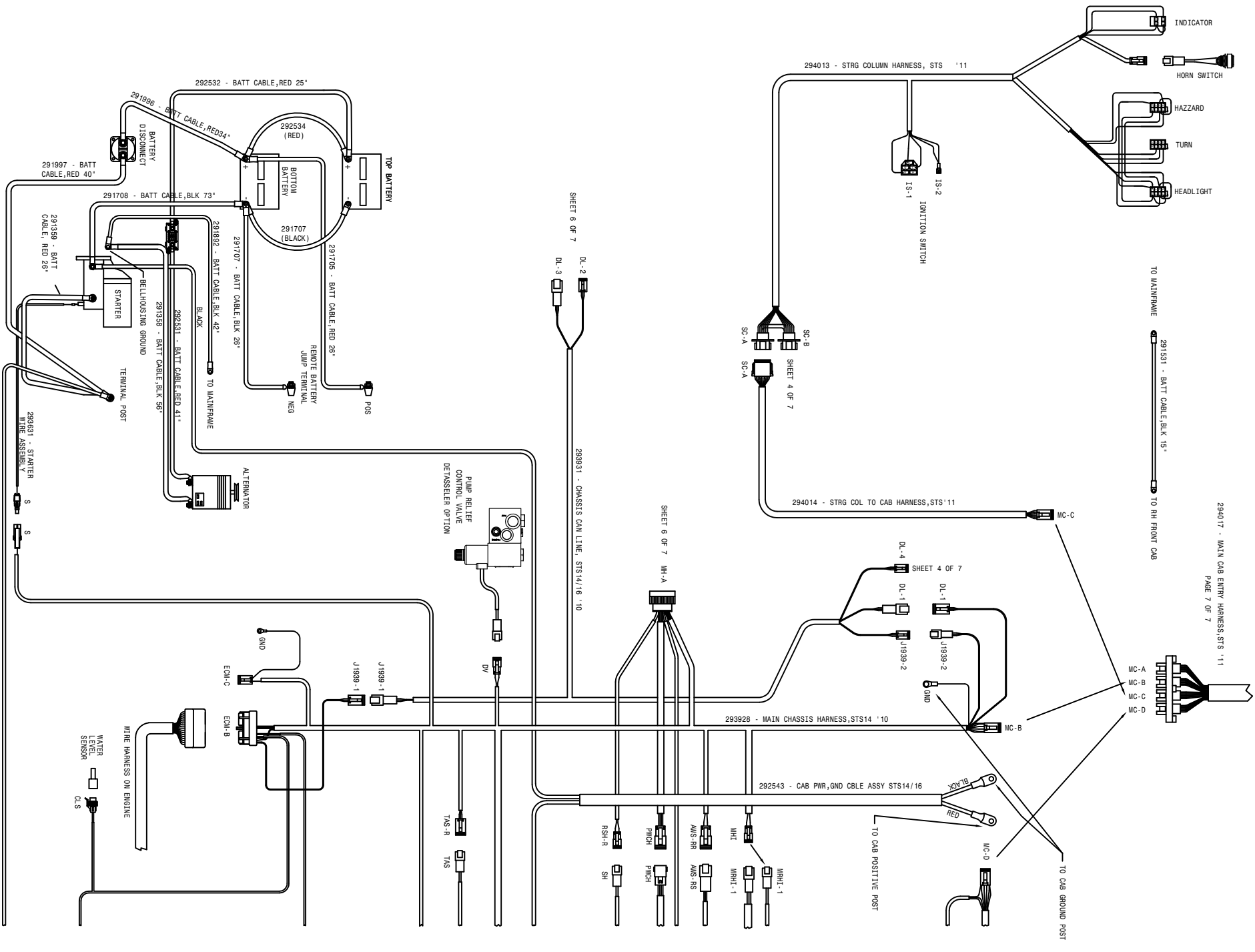

294017 - MAIN CAB ENTRY HARNESS, STS '11
PAGE 7 OF 7

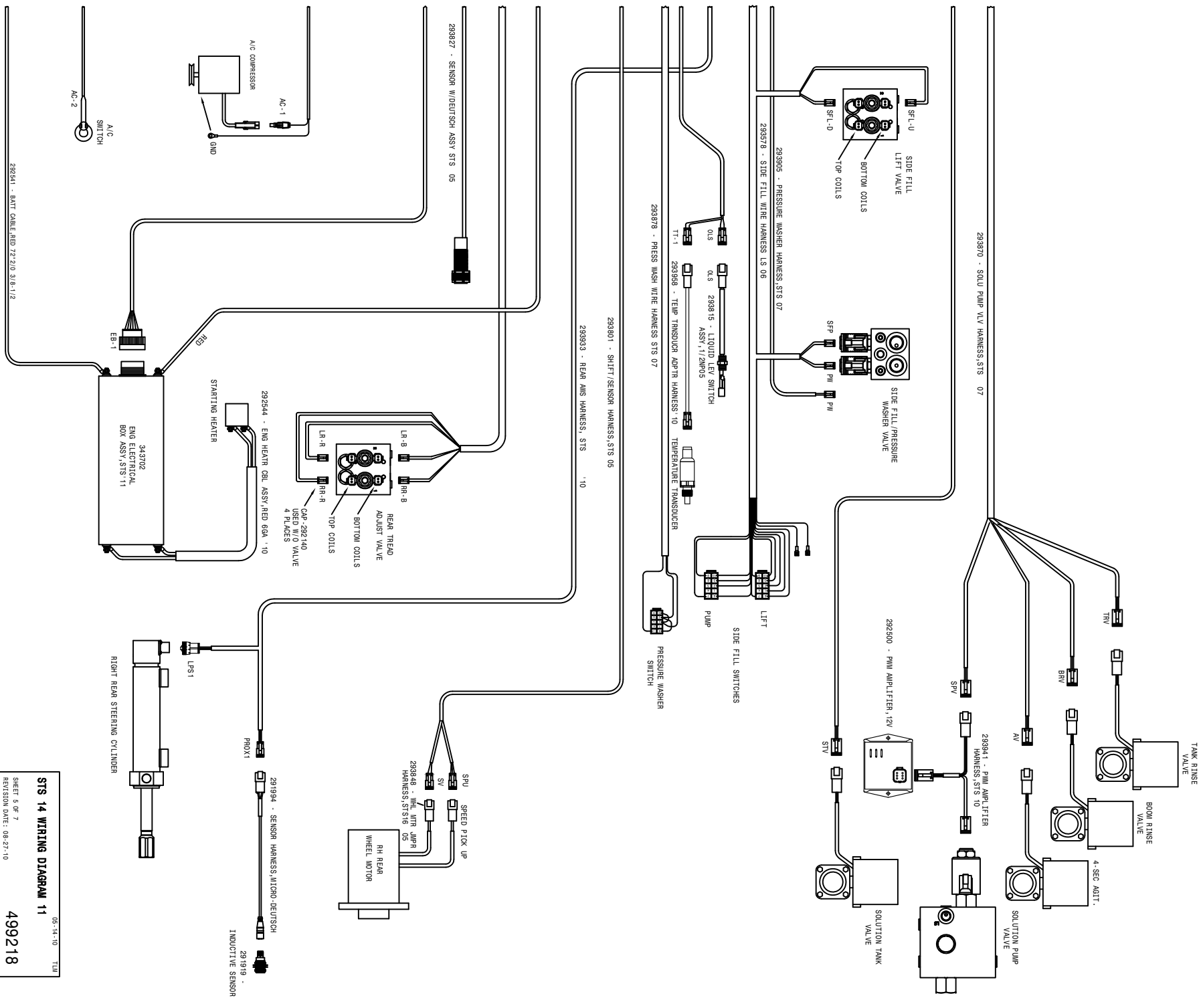

STS 14 WIRING DIAGRAM 11
 SHEET 5 OF 7
 REVISION DATE: 08-27-10
 499218
 05-14-10 TUM

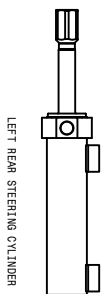
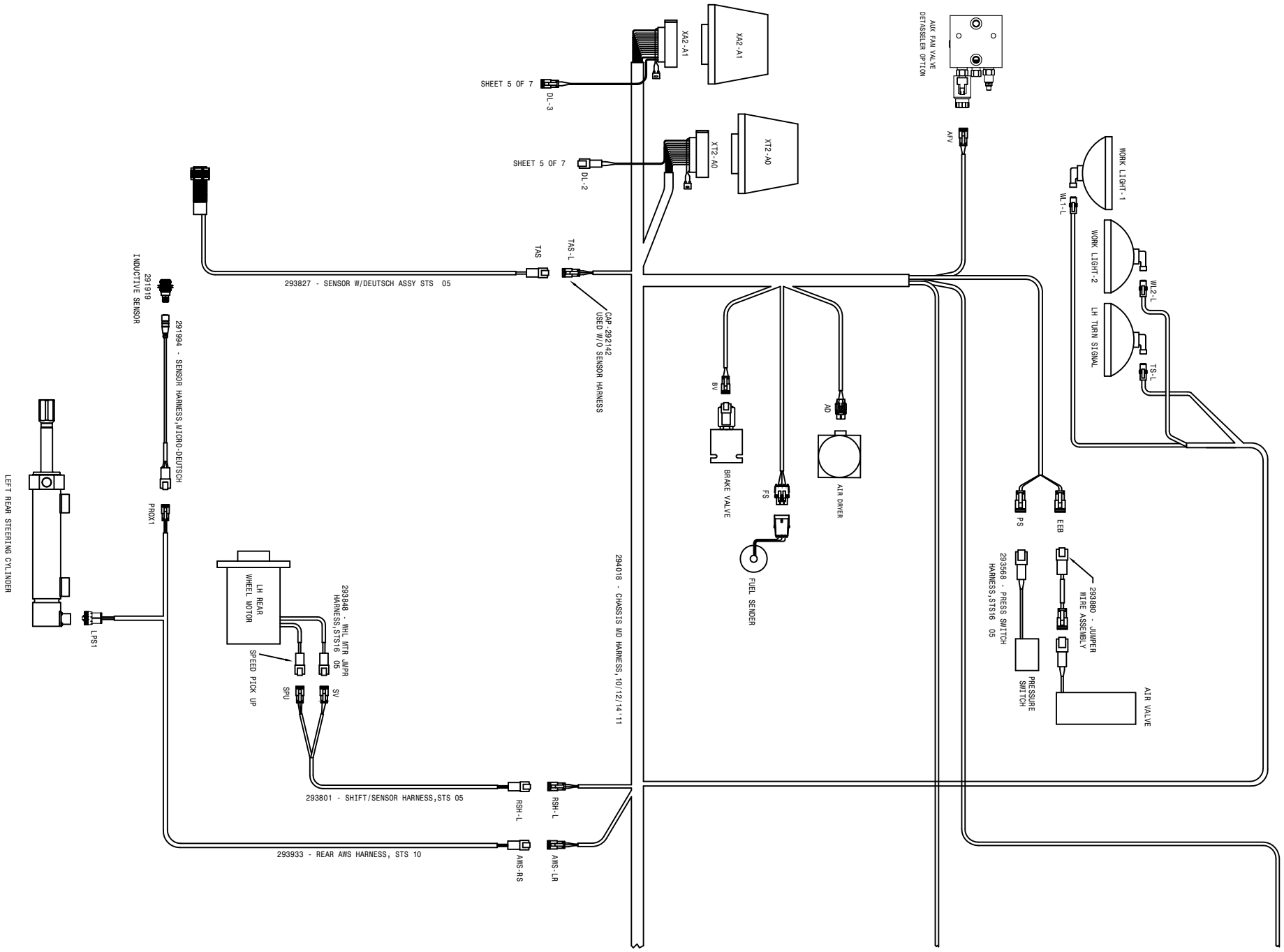

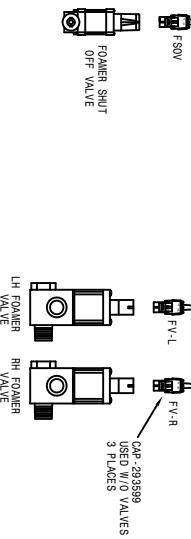
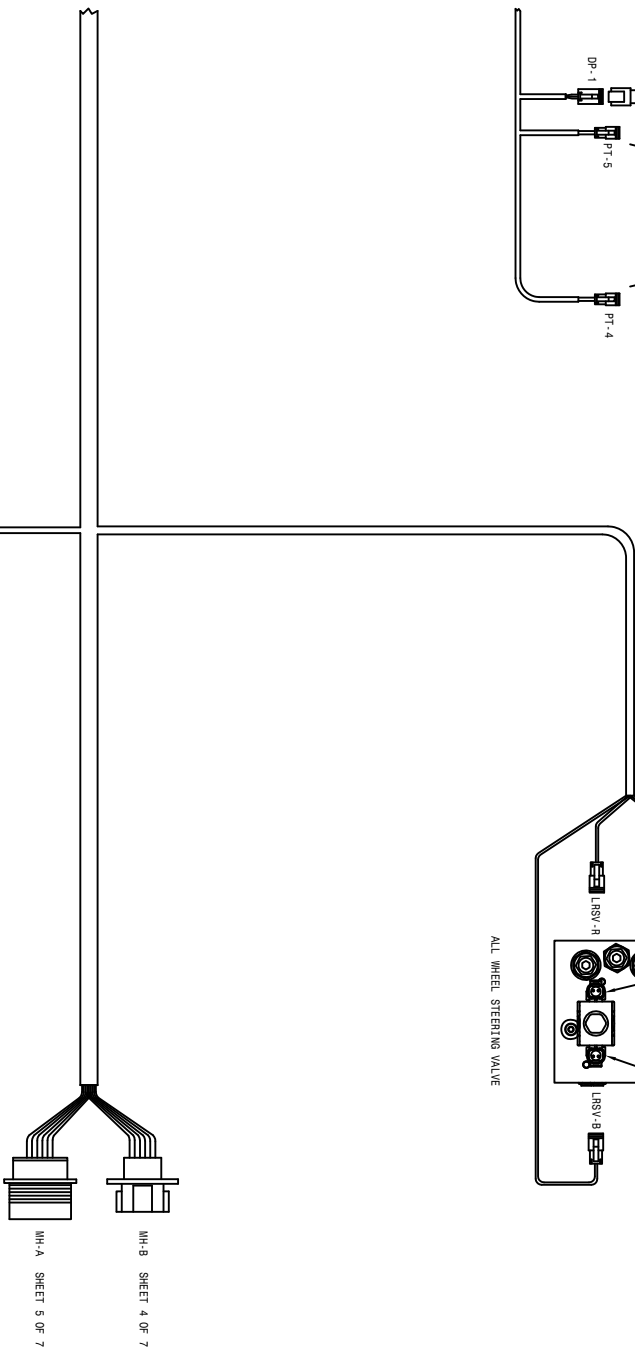
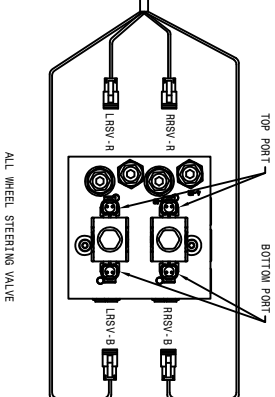
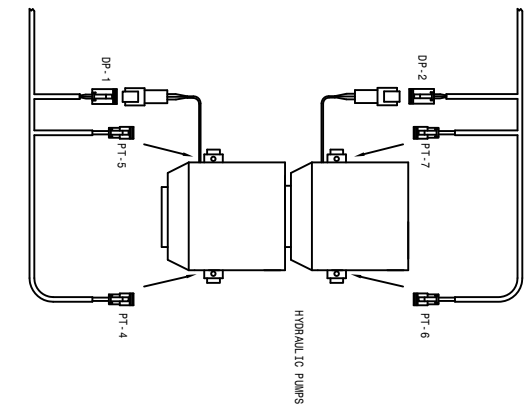

STS 14 WIRING DIAGRAM 11
 SHEET 6 OF 7
 REVISION DATE: 08-27-10
 499218
 05-14-10 TLU

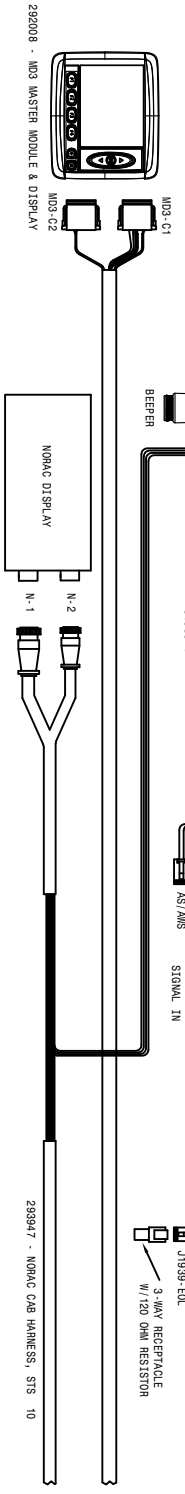
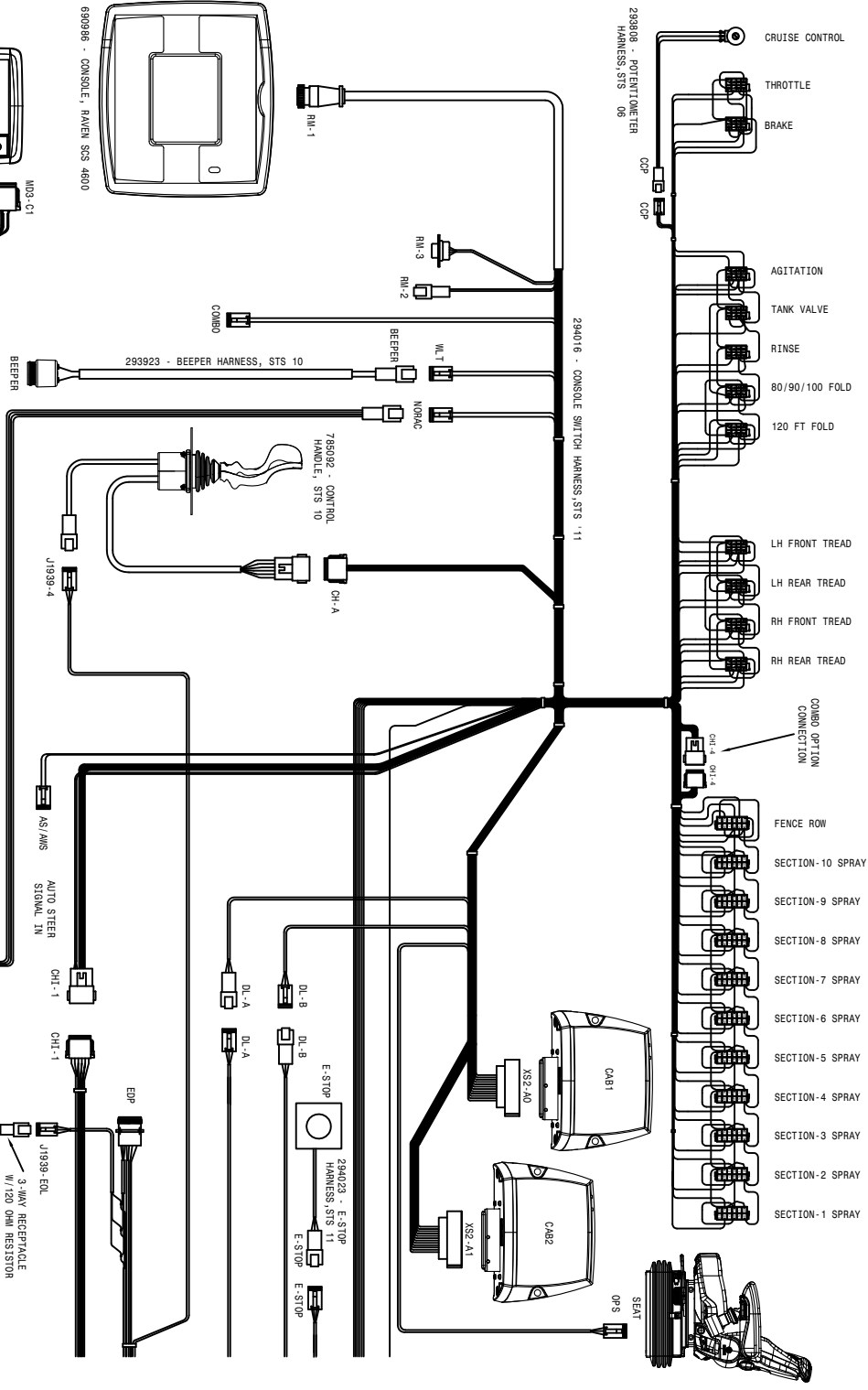
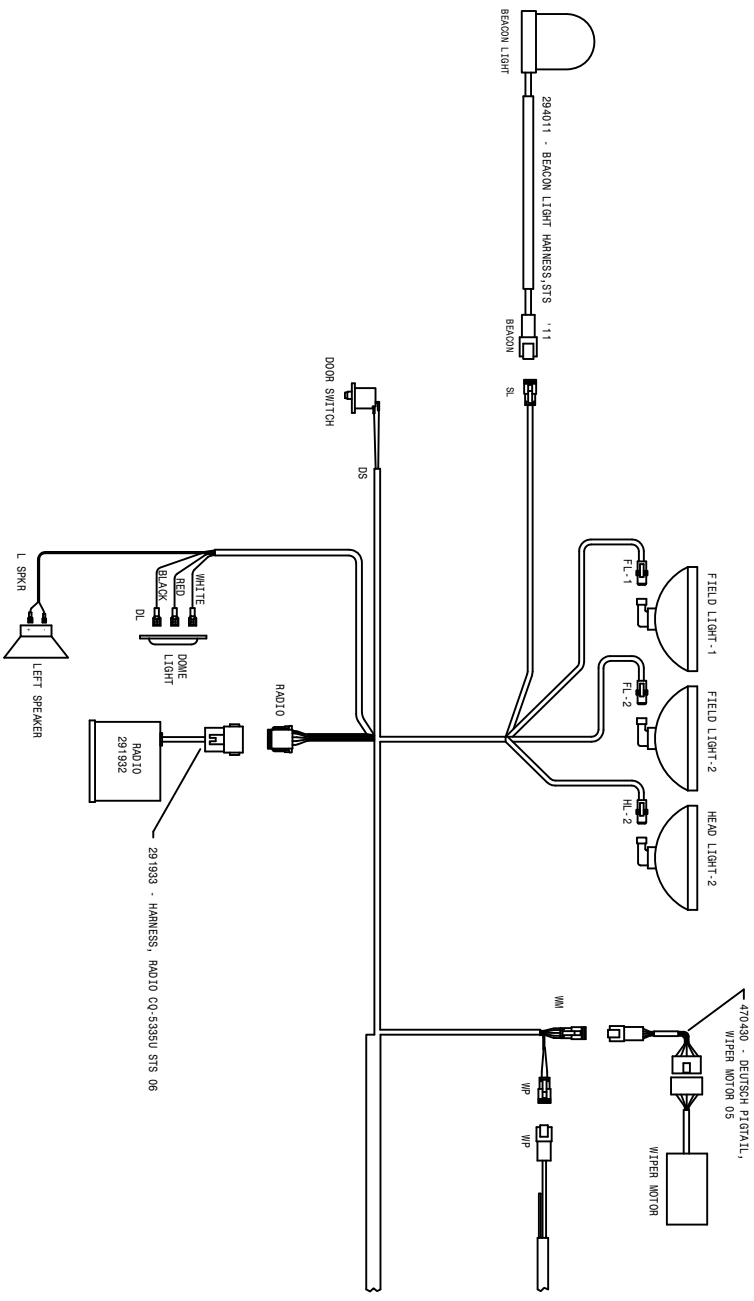

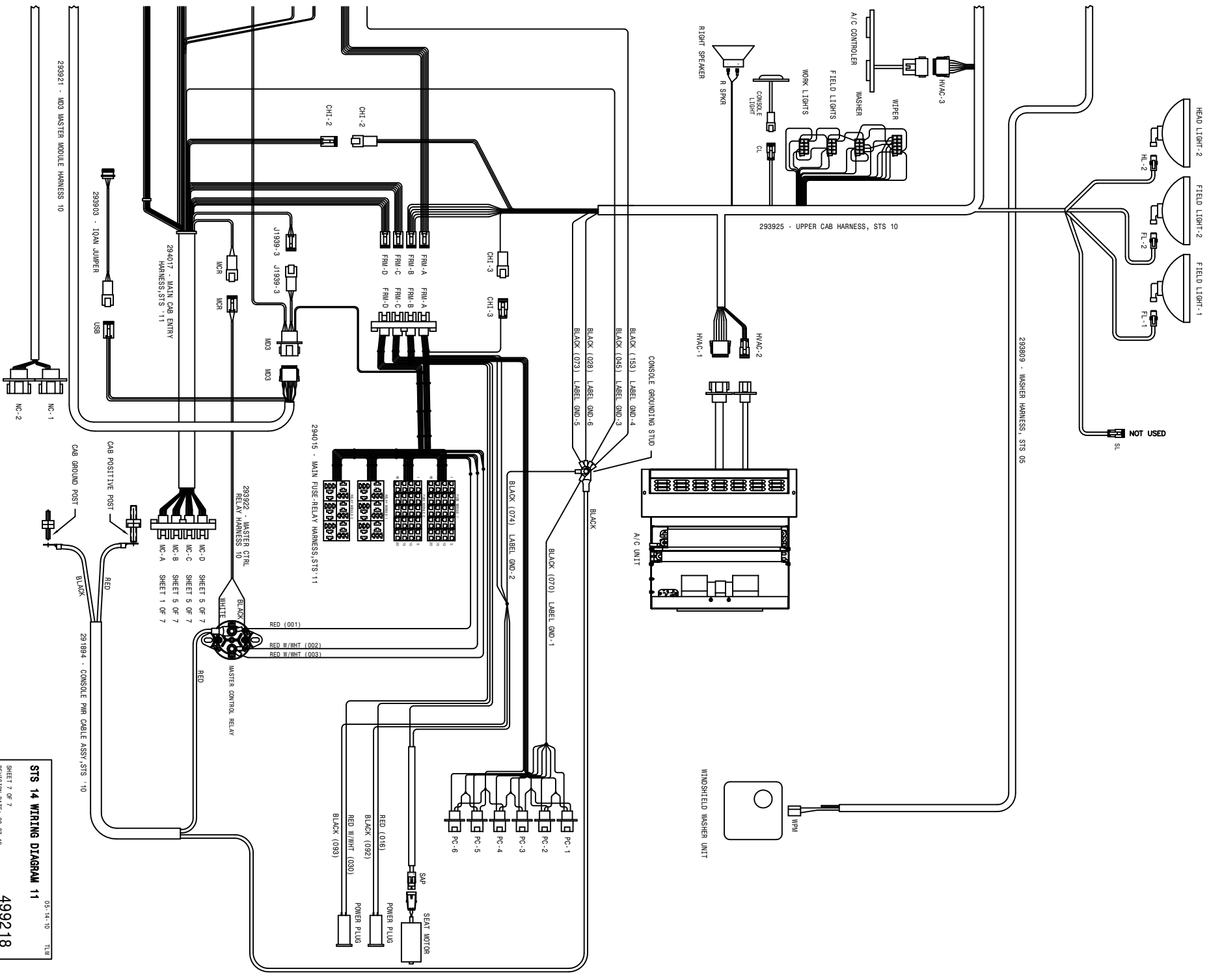

STS 14 WIRING DIAGRAM 11
 SHEET 7 OF 7
 REVISION DATE: 06-27-10
 05-14-10 TUL
499218

ABBREVIATIONS

ADPTR - ADAPTER	MTR - MOTOR
AGI - AGITATOR	P/N - PART NUMBER
ALT - ALTERNATOR	PLT - PLATE
ASSY - ASSEMBLY	QTY - QUANTITY
BRKT - BRACKET	RED - REDUCER
DET - DETAIL	REF - REFERENCE
DISPL - DISPLACEMENT	REST - RESTRICTOR
EL - ELBOW	REQ - REQUIRED
EXT - EXTENSION	SHFT - SHAFT
FLO - FLOW	SOL - SOLUTION
FNPT - FEMALE NATIONAL PIPE THREAD	STRG - STEERING
FOR - FEMALE O-RING	ST - STREET
FRT - FRONT	SV - STANDARD VOLUME
HV - HI-VOLUME	SWIV - SWIVEL
HYD - HYDRAULIC	UNC - UNIFIED NATIONAL COURSE
HYDRO - HYDROSTATIC	UNF - UNIFIED NATIONAL FINE
LG - LONG	V - VOLT
LWR - LOWER	W/ - WITH
MJIC - MALE J.I.C.	WHL - WHEEL
MOR - MALE O-RING	WLD - WELDMENT

INDEX

-A-

ABBREVIATIONS.....168
 ACCUMULATOR.....93
 AIR DRYER.....39
 AIR CLEANER.....10
 FILTER.....10
 AIR COMPRESSOR GOVERNOR.....10
 AIR CONDITIONER
 BINARY SWITCH.....8
 COMPRESSOR.....6
 CONDENSOR COIL.....9
 CONTROLLER.....44
 HOSE.....8,9
 RECEIVER/DRYER.....8
 TUBE.....29
 AIR COOLER, CHARGE.....9
 AIR PRESSURE GAUGE.....109
 AIR REGULATOR, FOAMER.....109
 AIRRIDE SPRING.....16,18,20,22
 AIR VALVE.....16,18,20,22
 ALTERNATOR.....5
 ARM, STEERING.....16,18,20,22

-B-

BACK-UP BEEPER.....9
 BALL VALVE.....67,75
 ELECTRIC.....69,70,71,72,79
 BATTERY.....14
 CABLE.....4,5,10,14
 BOX PANEL.....9
 BEARING,
 BRONZE LEG.....16,18,20,22,24
 ORKOT.....16,18,20,22
 BELT,
 AIR CONDITIONER.....6
 DRIVE.....5
 BLOCK, TERMINAL.....56
 BOOM.....95,96,97,98
 CRADLE.....99,100,107
 INDICATOR LIGHT.....89
 PIN.....97,98
 STAND.....125
 SWITCH.....53
 VALVE.....90
 WET.....126,127,128,129
 BOX,
 ELECTRICAL.....60
 PRESSURE WASHER.....115
 SIDE FILL.....119
 BRACE, RADIATOR.....8
 BREAKAWAY CYLINDER.....98,104
 BUMPER, REAR.....62

-C-

CAB.....42,43
 ROOF.....42,43
 CABLE BATTERY.....4,5,10,14
 CAP,
 FUEL.....12
 RADIATOR.....9
 CHARGE AIR COOLER.....9
 CHEMICAL INDUCTOR.....120
 COMPRESSOR, A/C.....6
 CONDENSOR COIL, A/C.....9
 CONSOLE.....54
 COOLER, OIL.....9
 CRADLE, BOOM.....97,99,107
 CYLINDER,
 BREAKAWAY.....98,104
 FOLD.....94,97,101,103
 GAS.....62
 LEVEL.....94,102
 LADDER.....37
 LIFT.....93
 SIDE FILL.....120
 STEERING.....15,16,18
 TREAD ADJUST.....24,25

-D-

DECALS.....144,145
 DIAGRAMS, WIRING.....154
 DOOR.....50,51
 LATCH.....40,51,62,63
 DRAIN COCK, AIR.....41
 DRIVE
 BELT.....5
 DISK.....4

-E-

ELECTRIC BALL VALVE.....69,70,80,81
 ELECTRICAL BOX.....59
 ENGINE.....60
 ENGINE.....4,5
 HOOD.....62,63
 SKID.....8

-F-

FAN.....5
 SPACER.....5

FEEDER TEE.....73,74,82,83
FENCE ROW NOZZLE.....86,87
FENDER.....122,123
FILTER,
AIR CLEANER.....10

CAB.....42
FUEL.....4
HYDRAULIC.....13
MINDER.....109
OIL.....5,13
FLASHER.....58,62
FLOW METER.....70,79
FOAMER

AIR REGULATOR.....109
DROP HOSE.....112
HOSING.....111
TANK.....108
THREE-WAY VALVE.....108
VALVE.....108
FOLD CYLINDER.....94,97,101
FRESH WATER.....109
FRONT FILL.....121
FUEL,
CAP.....12
SENDER.....12
TANK.....12

-G-

GAUGE,
AIR PRESSURE.....109
SOLUTION.....70,79
GLASS.....42,43

-H-

HANDRAIL.....38
HEADLINER.....44
HEATER TUBE.....29
HOOD, ENGINE.....62,63
HOSE, A/C.....8
HOSING,
FOAMER.....111
SOLUTION.....67,68,76,77
HUB, TORQUE.....17,19,21,23
HYDRAULIC,
FILTER.....13
LEVER.....55
MANIFOLD.....30,31,32,33
SCHEMATIC.....146
TANK.....13
TUBE.....28,29,93,96
VALVE.....30,34,36
HYDROSTATIC PUMP.....7

-I-

IGNITION SWITCH.....49

INDICATOR LIGHT, BOOM.....89

-L-

LADDER.....37
CYLINDER.....37
PIVOT ARM.....37
LEG.....16,18,20,22
LEVEL CYLINDER.....94,102
LEVER,
HYDROSTATIC.....55
QUICK ATTACH.....92
LIFT CYLINDER.....93
LIFTARM.....93
LIGHT.....28,42,43,106,107
LINE STRAINER.....64,66
LIQUID LEVEL SWITCH.....13

-M-

MDM DISPLAY.....44
MIRROR.....42,43
MONITOR, SPRAYER.....52
MOTOR,
STEERING.....48
WHEEL.....17,19,21,23
MOUNT, RUBBER.....8,43
MUFFLER.....11

-N-

NOZZLE,
BODY.....85
FENCE ROW.....86,87
MOUNT TUBE.....96,97,87
REAR WHEEL.....88

-O-

OIL COOLER.....9
OIL FILTER.....5,13

-P-

PANEL,
BATTERY BOX.....9
SWITCH.....53
PLATFORM, SERVICE.....38
PRESSURE GAUGE.....70,79
PRESSURE TRANSDUCER.....30,33
PRESSURE WASHER.....116
BOX.....115
VALVE.....116
PUMP,
HYDRAULIC.....4
HYDROSTATIC.....7
SIDE FILL.....120
SOLUTION.....69

-R-

RADIATOR.....9
 BRACE.....8
 CAP.....9
 HOSE.....5
 RADIO.....44
 REAR WHEEL NOZZLE.....88
 RINSE TANK.....64
 RUBBER
 MOUNT.....8,9,43
 SPRING.....16,18,20,22

-S-

SCHEMATIC, HYDRAULIC.....146
 SEAT.....45,46
 SENDER, FUEL.....12
 SENDER, WATER LEVEL.....9
 SERVICE PLATFORM.....38
 SHEET METAL.....63
 SHIELD, WHEEL MOTOR..17,19,21,23
 SIDFILL.....120
 BOX.....119
 CYLINDER.....120
 SIGHT GAUGE, OIL.....13
 SKID, ENGINE.....8
 SMV SIGN.....62
 SOLUTION
 HOISING.....67,68,76,77
 PUMP.....69
 TANK.....65
 VALVE.....34,70,72,79
 SPACER, FAN.....5
 SPEAKER.....44
 SPRAY MONITOR.....52
 SPRING,
 AIRRIDE.....16,18,20,22
 SOLUTION TANK.....65
 STAND, BOOM.....125
 STARTER.....5
 STEERING,
 ARM.....16,18,20,22
 COLUMN.....49
 CYLINDER.....16,18
 MOTOR.....48
 STRAINER, LINE.....66,69
 SWITCH,
 A/C BINARY.....8
 IGNITION.....49
 LIQUID LEVEL.....13
 PANEL.....53

-T-

TAILLIGHT.....62
 TANK
 AIR.....40,41
 FOAMER.....108
 FRESHWATER.....109
 FUEL.....12
 HYDRAULIC.....13
 RINSE.....64
 SOLUTION.....65
 TERMINAL BLOCK.....56
 TIRE.....15
 TORQUE HUB.....17,19,21,23
 TRANSOM.....94
 TREAD ADJUST
 CYLINDER.....24,25
 VALVE.....26,27
 TUBE,
 A/C.....29
 HEATER.....29
 HYDRAULIC.....28,29,93,96

-V-

VALVE,
 AIR.....16,18,20,22
 BALL.....65,75
 BOOM.....90
 ELECTRIC BALL.....64,69,70,79
 FOAMER.....108,113,114
 HYDRAULIC.....34,36
 PRESSURE WASHER.....106
 SIDE FILL.....103
 SOLUTION.....34,70,72,75
 TREAD ADJUST.....26,27

-W-

WASHER, PRESSURE.....116
 WATER LEVEL SENSOR.....9
 WET BOOM.....126,127,158,129
 WHEELMOTOR.....17,19,21,23
 SHIELD.....17,19,21,23
 WIRING DIAGRAM.....154

Notes: