



CONTENTS

1 – INTRODUCTION

A Word From Hagie Manufacturing Company 1-1
About This Manual 1-1
Safety Messages Used In This Manual 1-1
Service and Assistance 1-2
Product Warranty 1-2
Identification 1-2
Specifications 1-6

2 – SAFETY AND PRECAUTIONS

Intended Use 2-1
Safety Precautions 2-1
Seat Belt 2-6
Rotating Beacon 2-6
Emergency Stop 2-7
Emergency Exit 2-7
Fire Extinguisher 2-8
First Aid Kit 2-8
Roll-Over Protection Structure (ROPS) 2-9
Safety Decals 2-10

3 – CAB

Seat - Operator 3-1
Seat - Operator (Premium) 3-2
Seat - Instructor 3-4
Operator’s Station 3-5
Machine Display 3-28

4 – ENGINE AND DRIVE SYSTEMS

Engine - Starting 4-1
Engine Aftertreatment - Final Tier 4 4-3
Hydrostatic Drive 4-10
All-Wheel Steer (AWS) 4-15

5 – HYDRAULIC SYSTEMS

Hydraulic System Components 5-1
Reversible Fan 5-5
Tread Adjustment - Hydraulic 5-6
Ladder 5-10
Pressure Washer 5-11

6 – ELECTRICAL SYSTEMS

Batteries 6-1

| | |
|--------------------------------------|------|
| Battery Disconnect Switch | 6-3 |
| Battery Tender | 6-4 |
| Fuses and Relays | 6-5 |
| Fuse and Relay Ratings | 6-10 |
| Video Camera Input Connections | 6-13 |

7 – SPRAY SYSTEMS

| | |
|---|------|
| Spray Boom Hose Ring Installation | 7-1 |
| Spray Booms - 90/100' | 7-2 |
| Spray Booms - 120/132' | 7-13 |
| Spray Boom - Rear | 7-26 |
| Solution System Components | 7-28 |
| Solution System - Operation | 7-37 |
| Fence Row Applicator | 7-40 |
| Filling Your Solution Tank | 7-41 |
| Draining Your Solution Tank | 7-47 |
| Rinse System | 7-48 |
| Foam Marker System | 7-52 |
| Modular Injection System | 7-55 |
| Application | 7-64 |

8 – DUAL PRODUCT SPRAY SYSTEMS

| | |
|--|------|
| Solution System Components - Dual Product | 8-1 |
| Solution System Operation - Dual Product | 8-12 |
| Rinse System - Dual Product | 8-17 |
| Filling Your Solution Tank - Dual Product | 8-30 |
| Draining Your Solution Tank - Dual Product | 8-34 |
| Application - Dual Product | 8-35 |

9 – MAINTENANCE AND STORAGE

| | |
|-----------------------------------|------|
| Service - Fluids | 9-1 |
| Service - Filters | 9-10 |
| Service - Lubrication | 9-22 |
| Service - Engine Drive Belt | 9-27 |
| Service - Bolt Torque | 9-28 |
| Service - Toe-In | 9-30 |
| Service - Miscellaneous | 9-32 |
| Service Intervals | 9-36 |
| Storage | 9-40 |

10 – MISCELLANEOUS

| | |
|---------------------------------------|-------|
| Transporting | 10-1 |
| Lifting Your Machine | 10-4 |
| Quick-Tach System - Spray Booms | 10-6 |
| Air Suspension Exhaust | 10-17 |
| Hand Wash System | 10-18 |
| Hood Operation | 10-20 |



| | |
|--|-------|
| Ladder - Fuel Fill | 10-21 |
| Tall Crop Package - Installation | 10-24 |
| Troubleshooting | 10-37 |



SECTION 1 – INTRODUCTION

A WORD FROM HAGIE MANUFACTURING COMPANY

Congratulations on the purchase of your STS Sprayer! Read this operator's manual and become familiar with operating procedures and safety precautions before attempting to operate your sprayer.

As with any piece of equipment, certain operating procedures, service, and maintenance are required to keep your machine in top running condition. We have attempted herein to cover all of the adjustments required to fit varying conditions. However, there may be times when special care must be considered.

NOTE: The operator is responsible for inspecting the machine and its attachments, as well as having parts repaired or replaced when continued use of the product causes damage or excessive wear to other parts.

Hagie Manufacturing Company reserves the right to make changes in the design and material of any subsequent sprayer without obligation to existing units.

Thank you for choosing a Hagie sprayer and we ensure you of our continued interest and support in its optimal performance for you. We are proud to have you as a customer!

ABOUT THIS MANUAL

NOTICE

Any pictures or illustrations contained within this manual that depict situations with shields, guards, rails, or lids removed are for demonstration only. Keep all shields and safety devices in place at all times.

This manual will aid you in the proper operation and service of your machine. It is the responsibility of the user to read the operator's manual and comply with the correct and safe operating procedures, as well as maintain the product according to the service information provided in the *Maintenance and Storage Section* elsewhere in this manual.

Photographs and illustrations used in this manual are of general nature only. Some of the equipment and features shown may not be available on your machine.

Information described in this manual was correct at the time of printing. Because of Hagie Manufacturing Company's continuous product improvement, certain information may not be included in this manual. To obtain the most current operator's manual for your machine, please visit www.hagiehelp.com.

Keep this manual in a convenient place for easy reference. This manual is considered a permanent fixture of the product. In the event of resale, this manual must accompany the machine.

If you do not understand any part of this manual or require additional information or service, contact your local John Deere dealer for assistance.

SAFETY MESSAGES USED IN THIS MANUAL

The following safety messages found throughout this manual alert you of situations that could become potentially dangerous to the operator, service personnel, or equipment.

DANGER

This symbol indicates a hazardous situation which, if not avoided, will result in serious injury or death.

! WARNING

This symbol indicates a potentially hazardous situation which, if not avoided, could result in moderate/serious injury or death.

! CAUTION

This symbol indicates a potentially hazardous situation which, if not avoided, may result in minor or moderate injury. It may also be used to alert against unsafe practices.

NOTICE

This symbol indicates operator awareness which, if not avoided, may result in personal or property damage.

NOTE: A “Note” is intended to make special mention of, or remark on.

SERVICE AND ASSISTANCE

Please contact your local John Deere dealer for service and assistance.

PRODUCT WARRANTY

Please contact your local John Deere dealer for further information.

IDENTIFICATION

NOTICE

Reference to right and left-hand used throughout this manual refers to the position when seated in the operator’s seat facing forward.

Each machine is identified by means of a frame serial number. This serial number denotes the model, year in which it was built, and the number of the sprayer.

For further identification, the engine, solution pump, hydraulic pumps, and attachments each have serial numbers, and the planetary wheel hubs have identification plates that describe the type of mount and gear ratio.

To ensure prompt, efficient service when ordering parts or requesting service repairs, record the serial numbers and identification numbers in the following spaces provided.

Machine

The machine serial number is stamped on the front right-hand side of frame (behind the front leg).

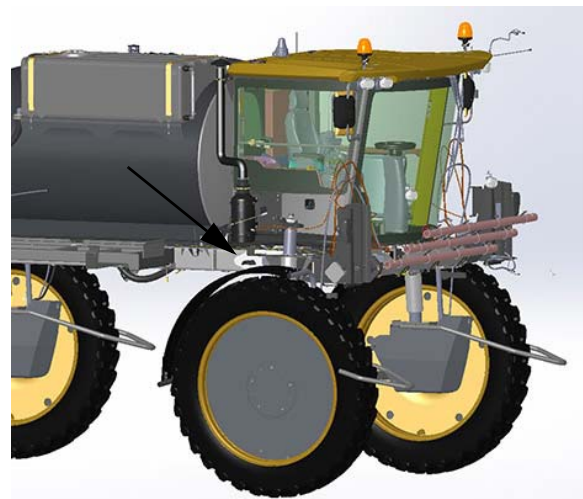

Machine Serial Number
-Typical View

Serial No. _____

Engine

The engine has an identification plate located on the right-hand side (above batteries) that provides engine serial number, as well as other manufacturer information. Refer to your Parts Manual for specific part number.



Engine Identification Plate
-Typical View

Serial No. _____

Solution Pump

The solution pump has an identification plate mounted on the side of pump that provides pump serial number, as well as other manufacturer information. Refer to your Parts Manual for specific part number.



Solution Pump Identification Plate
* View shown from beneath machine
-Typical View

Serial No. _____

Hydraulic Pumps

The PC, LS, Fan, and Drive Pumps each have an identification plate mounted on the side of pump that provides pump serial number, as well as other manufacturer information. Refer to your Parts Manual for specific part number.

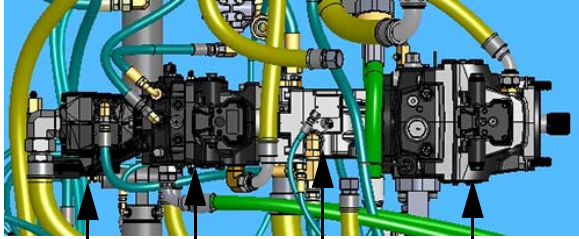

- PC Pump
- Fan Pump
- LS Pump
- Drive Pump

Hydraulic Pumps
* Top view shown
-Typical View

- _____ PC Pump
- _____ Fan Pump
- _____ LS Pump
- _____ Drive Pump

Wheel Motors

The wheel motors each have an identification plate mounted on the side of motor that provides motor serial number, as well as other manufacturer information. Refer to your Parts Manual for specific part number.



Wheel Motor Identification Plates
-Typical View

- _____ Right Front
- _____ Right Rear
- _____ Left Front
- _____ Left Rear

Wheel Hubs

The wheel hubs each have an identification plate mounted on the front of hub that provides hub serial number, as well as other manufacturer information, including gear ratio. Refer to your Parts Manual for specific part number.

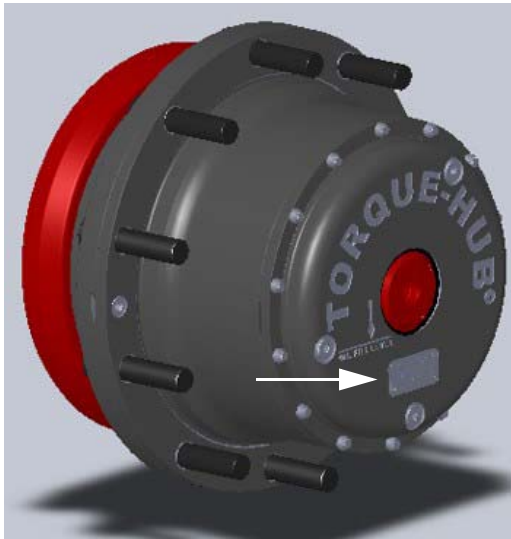

Wheel Hub Identification Plate
-Typical View

- _____ Right Front
- _____ Right Rear
- _____ Left Front
- _____ Left Rear

Spray Boom

Steel Spray Booms (90/100')

The steel spray boom serial number is stamped on the bottom right-hand side of transom.

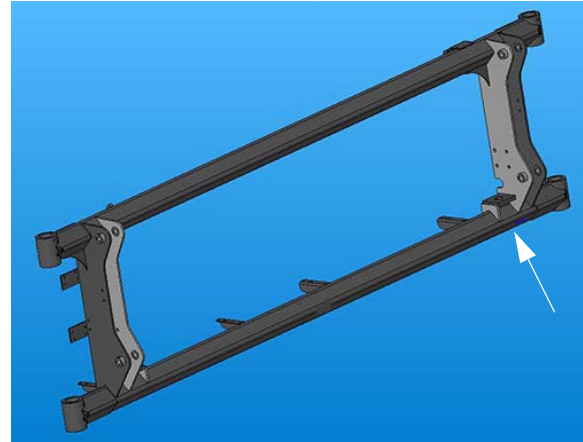

Steel Spray Boom Serial Number
-Typical View

Serial No. _____

Aluminum Spray Booms (120/132')

The aluminum spray boom serial number is stamped on the lower right-hand side of fixed transom.

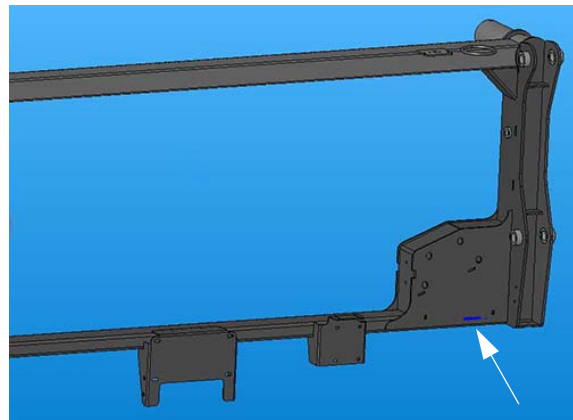

Aluminum Spray Boom Serial Number
-Typical View

Serial No. _____

SPECIFICATIONS

NOTE: Dimensions on your machine may vary, depending on tire size.

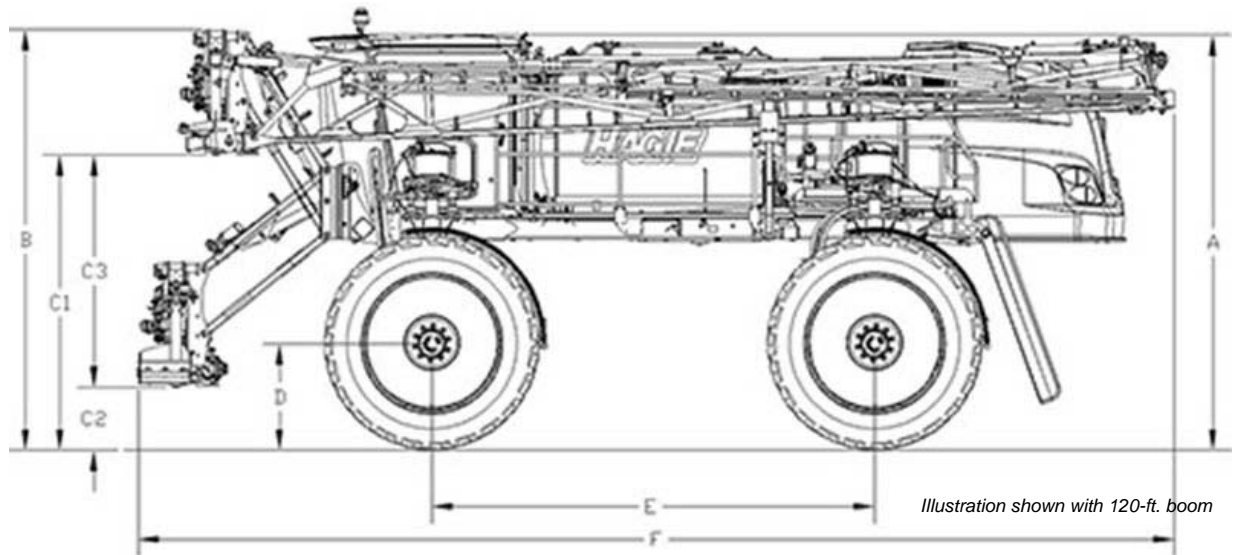

| Detail | Description | Specification | | | |
|--------|---|---|---|---|---|
| | | 90-ft. Boom | 100-ft. Boom | 120-ft. Boom | 132-ft. Boom |
| A | Overall Sprayer Height (from top of cab) <i>NOTE: Overall machine height dimension does not include the cab-mounted rotating beacons or the optional GPS unit.</i> | 151.5" ** (384.8 cm) ** | 151.5" ** (384.8 cm) ** | 151.5" ** (384.8 cm) ** | 151.5" ** (384.8 cm) ** |
| B | Raised Transom Height | 152.5" ** (387.4 cm) ** (from top of lights) | 152.5" ** (387.4 cm) ** (from top of lights) | 152.5" ** (387.4 cm) ** (from top of fixed transom) | 152.5" ** (387.4 cm) ** (from top of fixed transom) |
| C3 | Transom Lift Range (C1 minus C2) | 86" (104" - 18") 218.4 cm (264.2-45.7 cm) | 86" (104" - 18") 218.4 cm (264.2-45.7 cm) | 86" (104" - 18") 218.4 cm (264.2-45.7 cm) | 86" (104" - 18") 218.4 cm (264.2-45.7 cm) |
| D | Static Loaded Hub Height | 38 3/8" ** (97.5 cm) ** | 38 3/8" ** (97.5 cm) ** | 38 3/8" ** (97.5 cm) ** | 38 3/8" ** (97.5 cm) ** |
| E | Wheel Base | 166" (421.6 cm) | 166" (421.6 cm) | 166" (421.6 cm) | 166" (421.6 cm) |
| F | Sprayer Length <i>NOTE: Overall machine length will vary, depending on boom size. Dimensions do not include the optional rear boom.</i> | 336" (853.4 cm) | 336" (853.4 cm) | 370" (939.8 cm) | 410" (1041.4 cm) |
| G | Width (booms folded, 120"/304.8 cm tread) | 144" (365.8 cm) | 144" (365.8 cm) | 169" (429.3 cm) | 169" (429.3 cm) |
| H | Frame Clearance (to tread adjust bolts) | 73" (185.4 cm) ** | 73" (185.4 cm) ** | 73" (185.4 cm) ** | 73" (185.4 cm) ** |
| I | Lower Leg Clearance (from shield) | 29.5" (74.9 cm) ** | 29.5" (74.9 cm) ** | 29.5" (74.9 cm) ** | 29.5" (74.9 cm) ** |
| J | Tread Width* | 120" - In ** (304.8 cm - In) ** 160" - Out ** (406.4cm - Out) ** | 120" - In ** (304.8 cm - In) ** 160" - Out ** (406.4cm - Out) ** | 120" - In ** (304.8 cm - In) ** 160" - Out ** (406.4cm - Out) ** | 120" - In ** (304.8 cm - In) ** 160" - Out ** (406.4cm - Out) ** |

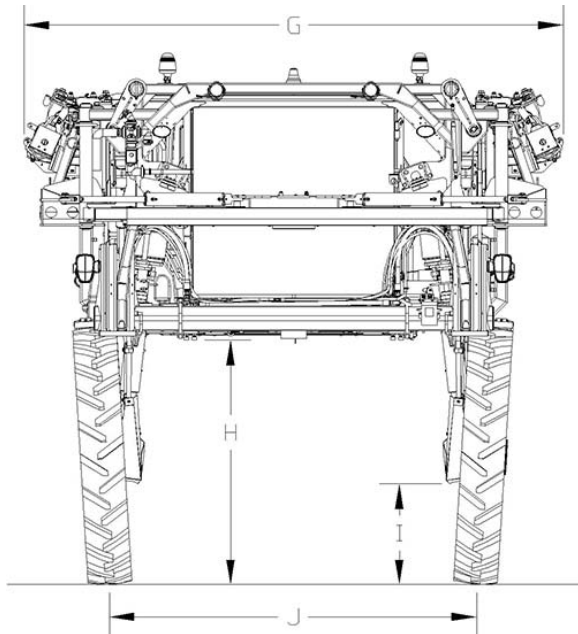

* Tread width is measured from center of tire at ground.

** Refer to “Tire Specifications” provided elsewhere in this section for a complete listing of tire options when configuring machine specifications on your model.

General Information

NOTICE

Because Hagie Manufacturing Company offers a variety of options, the illustrations in this manual may show a machine equipped other than standard. Height and weight values may vary, depending on available equipment.

- **Frame Type:** 4 x 8” (10.2 x 20.3 cm) modular platform frame
- **Suspension:** 4-wheel, individual, auto air-ride
- **Shipping Width:**
 - 144”/365.8 cm (with 90/100’ boom)
 - 169”/429.3 cm (with 120/132’ boom)
- **Approximate Dry Weight:**
 - 24,249 lbs./10,999 kg (machine only)
 - 28,589 lbs./12,967 kg (with 90’ boom)
 - 30,109 lbs./13,657 kg (with 120’ boom)

Spray System GPS Specifications -If Equipped

NOTE: Dimensions on your machine may vary, depending on tire size.

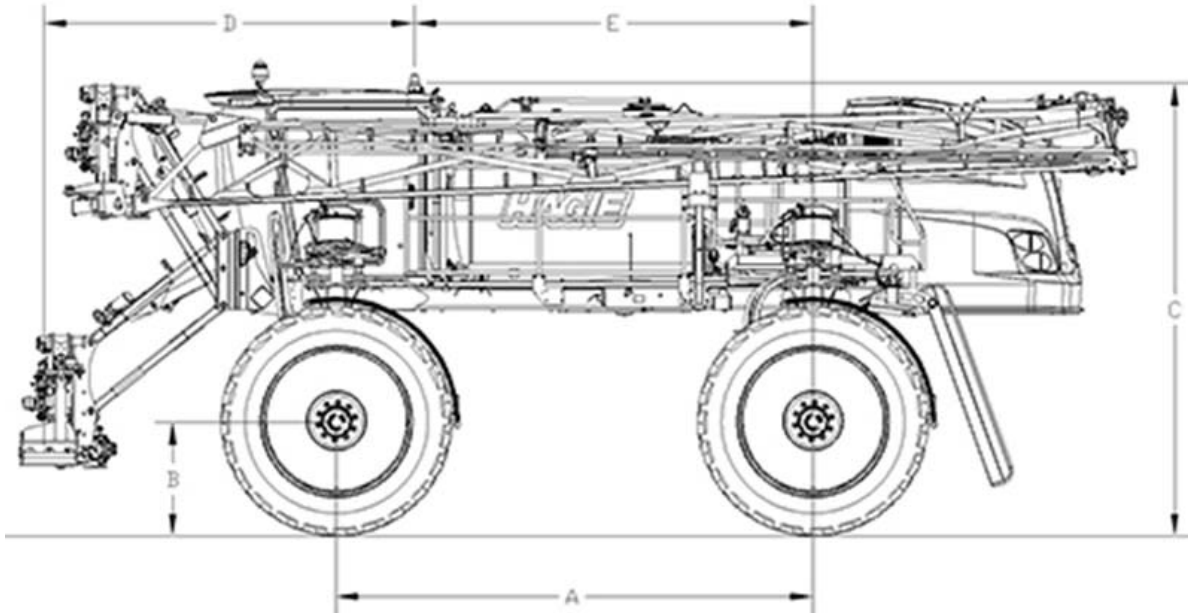

| Detail | Description | Specification |
|--------|---|-------------------|
| A | Wheel Base | 166" (421.6 cm) |
| B | Static Loaded Hub Height | 38 3/8" (97.5 cm) |
| C | Overall Sprayer Height (from middle of GPS unit) | 155" (393.7 cm) |
| D | Length (from front of boom spray tips to center of GPS unit) | 129.8" (329.7 cm) |
| E | Length (from center of GPS unit to center of rear hub) | 138.8" (352.6 cm) |



Settings and Calibration

Record settings and calibration values used in the following spaces provided when programming your spray system console. Refer to this information for future reference.

Circle the selected setting on the spray system console for the following options:

| | | | | | |
|---------------------|---------------------|----------------------------------|---|--|---|
| Units | • US (Acres) | | • SI (Hectares) | | • Turf (1,000 sq. ft./ 92 sq. m) |
| Speed Sensor | • SP1 (Wheel Speed) | | • SP2 (Radar/GPS) | | |
| Control Type | • Liquid Spray | • Gran 1 (Single Belt Bed) | • Gran 2 (Split Belt Bed/Single Encoder) | • Gran 3 (Split Belt Bed/Dual Encoders) | • Spinner RPM Control |
| Valve Type | • Standard Valve | • Fast Valve | • Fast Close Valve | • Pulse Width Modulated Valve | • Pulse Width Modulated Close Valve |

Record calculated calibration values in the spaces provided below.

| Speed Cal | Section Widths | Meter Cal | Rate Cal | Valve Cal | Tank Volume |
|-----------|----------------|-----------|----------|-----------|-------------|
| 1. | 1. | 1. | 1. | 1. | 1. |
| | 2. | 2. | 2. | 2. | 2. |
| | 3. | 3. | 3. | 3. | 3. |
| | 4. | 4. | 4. | 4. | 4. |
| | 5. | 5. | 5. | 5. | 5. |
| | 6. | | | | |
| | 7. | | | | |
| | 8. | | | | |
| | 9. | | | | |
| | 10. | | | | |

| Description | Specification |
|--|---|
| Engine | |
| Manufacturer | John Deere |
| Model | Final Tier 4 PSS 9.0L |
| Type | <ul style="list-style-type: none"> • Electronic w/Air-to-Air Cooler and Dual Turbo Charger • Diesel Oxidation Catalyst/Diesel Particulate Filter (DOC/DPF) • Cooled Exhaust Gas Recirculation (EGR) • Selective Catalytic Reduction (SCR) |
| Number of Cylinders | 6 |
| Displacement | 9.0L (549 c.i.) |
| Horse Power | <ul style="list-style-type: none"> • 375 hp (279 kW) @2200 rpm • 413 hp (308 kW) @2000 rpm (peak power) |
| Fuel Type | Ultra-Low Sulfur Diesel (ULSD) |
| Fuel System | Filtered, Direct-Injected |
| Air Cleaner | Dry-Type, Dual Element |
| Engine Air Filter Restriction Monitors | Engine Control Unit (ECU) |
| Slow Idle | 850 RPM |
| Fast Idle (no load) | 2200 RPM |
| Hydrostatic Drive | |
| Hydrostatic Pump | Danfoss H1-Series |
| Drive Train | All-Wheel 4-Wheel Drive |
| Speed Ranges | Speed Ranges 1-20 (operator selected) |
| <ul style="list-style-type: none"> • Solution Tank Transport Limit (Transportation Tank Level Switch) | 600 gallons (2271L) |
| Hydrostatic Wheel Motors | Danfoss H1-Series |
| Final Drives | Planetary Gear Reduction Hubs (Fairfield C017) |
| <ul style="list-style-type: none"> • Lubrication | Oil Bath |
| Brakes (Parking) | Multiple Disk, Spring Applied, Hydraulically Released |
| Brakes (Friction) | Hydraulically Applied (Front Wheels), Internal to Hubs |
| Auxiliary Hydraulic System | |
| Steering System | Hydraulic, Priority Circuit, PC Pump |



| | |
|---|---|
| • Control | Full-Time Power |
| • Steering Cylinders | Double Acting (w/dynamic alignment system*) * Under normal field conditions |
| • Turning Radius^ <i>NOTE: May vary, depending on tire size.</i> | <ul style="list-style-type: none"> • 27 ft./8 m (No AWS/AWS “Off”) • 20 ft./6 m (AWS “On”, if equipped) |
| All Wheel Steer (AWS) - if equipped^ | Coordinated Steering |
| Solution System Hydraulic Pump | Load Sense (LS) Pump |
| Cooling Fan Hydraulic Pump | Hydrostatic Closed-Loop Pump |
| Spray System | |
| Booms | 90/100/120/132-ft. (9 sections) |
| • Type | 1” (2.5 cm) Schedule 5 Stainless Wet Boom Plumbing |
| • Controls | Electro-Hydraulic (fold/lift/level) |
| • Level Shock Absorber | Gas-Charged Accumulator |
| • 90/100-ft. Outer Boom Hydraulic Breakaway | Self-Actuated, Auto Reset |
| • 120/132-ft. Inner Boom Breakaway | Hydraulic, Manual Reset |
| • 120/132-ft. Outer Boom Breakaway | Mechanical w/Spring, Auto Reset |
| Solution Fill Connection | |
| • Quick-fill Connection | 3” (7.6 cm) Inner Diameter |
| Solution Tank | Stainless Steel |
| Agitation | Jet-Type w/Electric Valve Variable Control |
| General Spray System | |
| • Pump | <ul style="list-style-type: none"> • Centrifugal-Hydraulically Driven w/Proportional Control Valve • Hypro® 9306-HM1C-BU w/Silicon Carbide Seals • 3” (7.6 cm) Inlet/2” (5.1 cm) Outlet Plumbing |
| • Flow Meter | Electromagnetic: 3-190 GPM (11.4-719.2 l/min) |
| • Boom Solution Valves | Ball Valves, Electric Actuation, Stainless Ball/ Stem, PTFE Seats |
| • Pressure Gauge | 100 PSI (6.9 bar), Glycerin Filled |
| • Console | <ul style="list-style-type: none"> • Raven (optional) • Ag Leader® (optional) • John Deere (optional) |
| • Fence Row Nozzle | Remote Activated (left and right) |
| • Rear Nozzle | Remote Activated |
| Solution Circuit Pressure (Maximum) | 100 PSI (6.9 bar) |



| Modular Injection System (if equipped) | |
|--|--|
| Chemical Tank(s) | 55 gallons (208L)/each |
| Injection Pump(s) | Raven Sidekick Pro™ (5-200 oz./min.) |
| Mixer | 3" (7.6 cm) Poly |
| Foam Marker System (if equipped) | |
| Make | Hagie Concentrate Foamer |
| Type | Boom Mix |
| Rinse System | |
| Spray System Rinse (solution tank, pump, and booms) | 2 Rotating Rinse Balls (inside tank) |
| Air Purge - if equipped | Remote Activated (purges pump suction line, pump, and boom plumbing) |
| Dual Product Spray System (if equipped) | |
| Boom Plumbing | <ul style="list-style-type: none"> • Single Product System (9-section 1"/2.5 cm schedule 5 stainless wet boom plumbing) • Dual Product System (5-section 1"/2.5 cm schedule 5 stainless wet boom plumbing) |
| Solution Tank | <ul style="list-style-type: none"> • Stainless Steel • 1600-gal./6056L (split) (Tank 1 = 1000-gal./3785L, Tank 2 = 600-gal./2271L) |
| Agitation | Jet-Type w/Electric Valve Variable Control |
| Solution Quick-Fill Connection | 3" (7.6 cm) Inner Diameter |
| General Spray System | |
| • Solution Pump (2) | <ul style="list-style-type: none"> • Centrifugal-Hydraulically Driven w/Proportional Control Valve • Hypro® 9306-HM1C-BU w/Silicon Carbide Seals • 3" (7.6 cm) Inlet; 2" (5.1 cm) Outlet Plumbing |
| • Flow Meter (2) | Electromagnetic: 3-190 GPM (11.4-719.2 l/min) |
| • Boom Solution Valves (2) | Ball Valves, Electric Actuation, Stainless Ball/ Stem, PTFE Seats |
| • Pressure Gauge (2) | 100 PSI (6.9 bar), Glycerin Filled |
| • Console | <ul style="list-style-type: none"> • Raven • Ag Leader® |
| Solution Circuit Pressure (Maximum) | 100 PSI (6.9 bar) |
| Rinse System | |
| • Spray System Rinse (solution tank, pumps, and booms) | Rotating Rinse Ball (inside each side of tank) |



| | |
|---|--|
| • Air Purge - <i>if equipped</i> | Remote Activated (purges pump suction line, pump, and boom plumbing) |
| • Rinse Tank | <ul style="list-style-type: none"> • Polyethylene • 100-gal. (378L) |
| Electrical System | |
| General Electrical System | |
| • Battery | Dual 12V, Negative Ground (CCA) |
| • Alternator | 240 AMP, Voltage Regulated |
| • Starter | 12V w/Solenoid |
| Lights (Exterior) | |
| • Front of Cab | 2 Trapezoidal Headlights, 2 Floodlights, 2 Rotating Amber Beacon Lights |
| • Transom | 2 Trapezoidal Headlights |
| • Quick-Tach Mount | 2 Trapezoidal Headlights (high/low beam), 2 Oval Amber Lights (combined) |
| • Boom Cradle | 2 Trapezoidal Floodlights (1 on each cradle), 2 Oval Amber Lights (1 on each cradle) |
| • Rear Engine Hood | 2 Round Red Lights, 2 Round Amber Lights |
| • Spray Boom Indicators (located on boom, if equipped) | 1 Oval White Light, 2 Oval Amber Lights, 9 Oval Red Lights |
| • Night Spray - if equipped | 2 Trapezoidal Lights (1 on each main boom fold section) |
| Cab and Instruments | |
| Sound Level (cab interior) | 86 dBA (maximum) |
| Cab (General) | Tilt Steering, Wipers/Washers, Dual Side Mirrors, Dome Light, Tinted Glass, Instructor Seat |
| Temperature Control | Full Range |
| A/C Charge Type | R-134A |
| Fresh Air Filtration | <ul style="list-style-type: none"> • RESPA® Cab Filter • Charcoal Filter |
| Seat | Air-Ride |
| Instruments | Tachometer (rpm), Fuel Level, Engine Coolant Temperature, Aftertreatment Level |



| | |
|---|---|
| Machine Display | Hour Meter, Battery Voltage, Engine Oil Pressure, Ground Speed, Engine Diagnostics, Tread Adjustment, Parking Brake, Machine/ Engine Malfunction Warnings, Engine Exhaust Filtration Warning, High Exhaust Temperature Warning, Low Hydraulic Oil Level, Low Coolant Level, Low Fuel Level, Cab Air Pressure |
| Stereo | AM/FM Radio w/CD, MP3, and Bluetooth |
| Fluid Capacities | |
| Solution Tank | 1600 gallons (6056L) |
| Fuel Tank | 150 gallons (567L) |
| Engine Oil Pan (including filter, remote lines, and cooler) | 34.4 quarts (32.6L), John Deere Plus-50™ II <i>NOTE: John Deere Break-In™ Plus special-purpose engine oil is to be used during the initial break-in period (first 500 hours of operation). Thereafter, John Deere Plus-50 II premium engine oil is to be used.</i> |
| Engine Oil Dipstick (L-H mark) | 2.3 quarts (2.2L) |
| Engine Cooling System (including block, lines, and radiator) | 11 gallons (41L), John Deere Cool -Gard™ II |
| Diesel Exhaust Fluid (DEF) Tank (Final Tier 4 Engines) | 7.8 gallons (29.5L), John Deere Diesel Exhaust Fluid (DEF) |
| Hydraulic Oil (including lines, filter, cooler, etc.) | 50 gallons (189L), John Deere Hy-Gard™ |
| Hydraulic Oil Reservoir | 34 gallons (128L) |
| Wheel Hubs (4) | <ul style="list-style-type: none">• 56 oz./1.7 L (w/o service brake)• 50 oz./1.5 L (w/ service brake) <i>NOTE: The above fluid capacities apply when filling a wheel hub for the first time. Refilling after draining during an oil change would require fewer ounces.</i> Oil Type: Mobiltrans™ AST oil (CAT T0-4 rated) |
| Rinse System Tank | 100 gallons (378.5L) |
| Hand Wash Tank | 4 gallons (15L) |
| Foam Marker Tank | 1 gallon (3.8L), Foam Concentrate |
| Air Conditioning System (Charge) | 4.00 lbs. (1.81 kg), R-134A |

^ Operators with machines equipped with All-Wheel Steer (AWS) pay special attention.



| TIRE SPECIFICATIONS (STANDARD) | | | | | | | | | | |
|--------------------------------|------------|-----------------------|-----------------------------------|------------------------------|-------------------------|----------------------------|------------------------------|------------------------------------|-----------------------------|--|
| Size | Make | Model | Load Rating (Weight/ Speed) | Air Pressure (Max PSI) | Tread Width (in.) | Load Capacity (lbs.) | Overall Diameter (in.) | Static Load Radius* (in.) | Rolling Circum. (in.) | Gross Flat Plate (in ²) |
| 650/65R38 | Alliance | 550 | 166D | 46 | 25.4 | 13,220 | 71.4 | 32.4 | 214.6 | --- |
| IF380/90R46 | Alliance | 363 | 168D | 64 | 15.3 | 12,330 | 72.5 | 33.6 | 220.8 | --- |
| IF480/80R50 | Alliance | 363 | 166D | 44 | 18.9 | 14,010 | 80.2 | 37.0 | 242.2 | --- |
| 650/65R38 | Firestone® | 9000 | 166D | 46 | 26.0 | 9,100 | 72.4 | 32.4 | 218.0 | 480 |
| VF380/105R50 | Firestone | Radial All Trac RC | 179D | 64 | 16.2 | 17,100 | 80.7 | 37.3 | 244.0 | 327 |
| 380/90R46 | Goodyear | Ultra Sprayer | 168A8 | 78 | 15.0 | 12,300 | 72.7 | 32.8 | 219.0 | --- |
| IF320/105R54 | Goodyear | Ultra Sprayer | 167D | 64 | 12.9 | 12,000 | 80.1 | 35.4 | 236.0 | 215 |
| IF380/105R50 | Goodyear | Ultra Sprayer | 177D | 70 | 14.9 | 16,100 | 80.7 | 36.1 | 241.0 | 305 |
| IF520/85R42 | Goodyear | Ultra Torq | 170A8 | 52 | 20.3 | 13,200 | 76.5 | 34.3 | 230.0 | --- |
| 480/80R42 | Goodyear | Dyna Torq | 166A8 | 58 | 18.7 | 11,700 | 73.3 | 33.3 | 221.0 | --- |
| VF380/90R46 | Michelin® | Spraybib | 173D | 64 | 15.1 | 14,330 | 72.5 | 33.4 | 217.7 | 267 |
| VF420/95R50 | Michelin | Spraybib | 177D | 52 | 16.3 | 16,094 | 80.8 | 36.9 | 240.9 | --- |
| VF480/80R50 | Michelin | Yieldbib | 166B | 23 | 18.4 | 11,680 | 80.3 | 35.5 | 237.6 | 450 |

* Static load radius is suggested and will vary with load.



| TIRE SPECIFICATIONS (METRIC) | | | | | | | | | | |
|------------------------------|-----------|--------------------|----------------------------|------------------------|------------------|--------------------|-----------------------|--------------------------|----------------------|-------------------------------------|
| Size | Make | Model | Load Rating (Weight/Speed) | Air Pressure (Max Bar) | Tread Width (cm) | Load Capacity (kg) | Overall Diameter (cm) | Static Load Radius* (cm) | Rolling Circum. (cm) | Gross Flat Plate (cm ²) |
| 650/65R38 | Alliance | 550 | 166D | 3.2 | 64.5 | 5,996 | 181.4 | 82.3 | 545.1 | --- |
| IF380/90R46 | Alliance | 363 | 168D | 4.4 | 38.9 | 5,592 | 184.2 | 85.3 | 560.8 | --- |
| IF480/80R50 | Alliance | 363 | 166D | 3.0 | 48.0 | 6,354 | 203.7 | 94.0 | 615.2 | --- |
| 650/65R38 | Firestone | 9000 | 166D | 3.2 | 66.0 | 4,127 | 183.9 | 82.3 | 553.7 | 3096.8 |
| VF380/105R50 | Firestone | Radial All Trac RC | 179D | 4.4 | 41.1 | 7,756 | 205.0 | 94.7 | 619.8 | 2109.7 |
| 380/90R46 | Goodyear | Ultra Sprayer | 168A8 | 5.4 | 38.1 | 5,579 | 184.7 | 83.3 | 556.3 | --- |
| IF320/105R54 | Goodyear | Ultra Sprayer | 167D | 4.4 | 32.8 | 5,443 | 203.5 | 89.9 | 599.4 | 1387.1 |
| IF380/105R50 | Goodyear | Ultra Sprayer | 177D | 4.8 | 37.8 | 7,302 | 205.0 | 91.7 | 612.1 | 1967.7 |
| IF520/85R42 | Goodyear | Ultra Torq | 170A8 | 3.6 | 51.6 | 5,987 | 194.3 | 87.1 | 584.2 | --- |
| 480/80R42 | Goodyear | Dyna Torq | 166A8 | 4.0 | 47.5 | 5,307 | 186.2 | 84.6 | 561.3 | --- |
| VF380/90R46 | Michelin | Spraybib | 173D | 4.4 | 38.4 | 6,500 | 184.2 | 84.8 | 553.0 | 1722.6 |
| VF420/95R50 | Michelin | Spraybib | 177D | 3.6 | 41.4 | 7,300 | 205.2 | 93.7 | 611.9 | --- |
| VF480/80R50 | Michelin | Yieldbib | 166B | 1.6 | 46.7 | 5,298 | 204.0 | 90.2 | 603.5 | 2903.2 |

* Static load radius is suggested and will vary with load.

SECTION 1 –
INTRODUCTION



| TIRE LOAD LIMITS (LBS) AT VARIOUS COLD INFLATION PRESSURES (PSI) | | | | | | | | | | | |
|--|-----------|-----------------|-------|-------|-------|-------|-------|--------|--------|--------|--------|
| | | Inflation (psi) | 6 | 9 | 12 | 15 | 17 | 20 | 23 | 26 | 29 |
| 650/65R38 | Alliance | | N/A | N/A | 5,880 | N/A | 7,440 | N/A | 8,810 | N/A | 10,040 |
| IF380/90R46 | Alliance | | N/A | N/A | 4,270 | N/A | 5,460 | 6,170 | 6,720 | N/A | 7,310 |
| IF480/80R50 | Alliance | | N/A | N/A | 5,810 | 6,520 | 7,310 | 8,260 | 9,030 | 9,520 | 9,780 |
| 650/65R38 | Firestone | | 4,180 | 5,080 | 5,840 | 6,800 | 7,600 | 8,250 | 9,100 | 9,650 | 9,900 |
| VF380/105R50 | Firestone | | 4,680 | 5,520 | 6,400 | 7,400 | 8,250 | 9,350 | 10,200 | 10,700 | 11,400 |
| 380/90R46 | Goodyear | | N/A | 3,300 | 3,860 | 4,400 | 5,080 | 5,520 | 6,150 | 6,400 | 6,800 |
| IF320/105R54 | Goodyear | | N/A | N/A | 4,540 | 5,080 | 5,840 | 6,400 | 7,150 | 7,400 | 7,850 |
| IF380/105R50 | Goodyear | | N/A | N/A | 5,520 | 6,400 | 7,150 | 8,050 | 8,800 | 9,100 | 9,650 |
| IF520/85R42 | Goodyear | | N/A | N/A | 6,950 | 7,850 | 8,800 | 9,900 | 10,700 | 11,400 | 11,700 |
| 480/80R42 | Goodyear | | N/A | 4,080 | 4,800 | 5,520 | 6,150 | 6,950 | 7,600 | 8,050 | 8,250 |
| VF380/90R46 | Michelin | | N/A | N/A | N/A | N/A | N/A | N/A | N/A | N/A | N/A |
| VF420/95R50 | Michelin | | N/A | N/A | N/A | N/A | N/A | N/A | N/A | 11,350 | 11,830 |
| VF480/80R50 | Michelin | | 5,200 | 6,240 | 7,290 | 7,330 | 9,370 | 10,530 | 11,680 | N/A | N/A |

| TIRE LOAD LIMITS (LBS) AT VARIOUS COLD INFLATION PRESSURES (PSI) - CONTINUED | | | | | | | | | | | |
|--|-----------|-----------------|--------|--------|--------|--------|--------|--------|--------|--------|--|
| | | Inflation (psi) | 35 | 41 | 46 | 52 | 58 | 64 | 70 | 75 | |
| 650/65R38 | Alliance | | 11,170 | 12,220 | 13,220 | N/A | N/A | N/A | N/A | N/A | |
| IF380/90R46 | Alliance | | 7,780 | 8,520 | 9,270 | 9,780 | 10,330 | 11,230 | N/A | N/A | |
| IF480/80R50 | Alliance | | 10,620 | N/A | N/A | N/A | N/A | N/A | N/A | N/A | |
| 650/65R38 | Firestone | | 10,700 | 11,700 | N/A | N/A | N/A | N/A | N/A | N/A | |
| VF380/105R50 | Firestone | | 12,000 | 13,200 | 13,900 | 15,200 | 15,700 | 17,100 | N/A | N/A | |
| 380/90R46 | Goodyear | | 7,150 | 7,850 | 8,550 | 9,100 | 9,650 | 10,500 | 11,400 | 12,000 | |
| IF320/105R54 | Goodyear | | 8,250 | 9,100 | 9,650 | N/A | 11,000 | 12,000 | N/A | N/A | |
| IF380/105R50 | Goodyear | | 10,200 | 11,400 | 12,000 | N/A | 13,600 | 14,800 | 16,100 | N/A | |
| IF520/85R42 | Goodyear | | 12,800 | N/A | N/A | N/A | N/A | N/A | N/A | N/A | |
| 480/80R42 | Goodyear | | 8,800 | 9,650 | 10,500 | 11,000 | 11,700 | N/A | N/A | N/A | |
| VF380/90R46 | Michelin | | 9,650 | 11,020 | 12,020 | 12,790 | 13,230 | 14,330 | N/A | N/A | |
| VF420/95R50 | Michelin | | 12,790 | 14,000 | 15,210 | 16,090 | N/A | N/A | N/A | N/A | |
| VF480/80R50 | Michelin | | N/A | N/A | N/A | N/A | N/A | N/A | N/A | N/A | |

NOTE: There are no adjustments to the loads and pressures in the above table for lower speeds or stationary service.

NOTE: Minimum inflation pressures for IF agricultural tires used as singles = 12 psi.



| TIRE LOAD LIMITS (KG) AT VARIOUS COLD INFLATION PRESSURES (BAR) | | | | | | | | | | | |
|---|-----------|-----------------|-------|-------|-------|-------|-------|-------|-------|-------|-------|
| | | Inflation (bar) | .4 | .6 | .8 | 1.0 | 1.2 | 1.4 | 1.6 | 1.8 | 2.0 |
| 650/65R38 | Alliance | | N/A | N/A | 405.4 | N/A | 513.0 | N/A | 607.4 | N/A | 692.2 |
| IF380/90R46 | Alliance | | N/A | N/A | 294.4 | N/A | 376.5 | 425.4 | 463.3 | N/A | 504.0 |
| IF480/80R50 | Alliance | | N/A | N/A | 400.6 | 449.5 | 504.0 | 569.5 | 622.6 | 656.4 | 674.3 |
| 650/65R38 | Firestone | | 288.2 | 350.3 | 402.7 | 468.8 | 524.0 | 568.8 | 627.4 | 665.3 | 682.6 |
| VF380/105R50 | Firestone | | 322.7 | 380.6 | 441.3 | 510.2 | 568.8 | 644.7 | 703.3 | 737.7 | 786.0 |
| 380/90R46 | Goodyear | | N/A | 227.5 | 266.1 | 303.4 | 350.3 | 380.6 | 424.0 | 441.3 | 468.8 |
| IF320/105R54 | Goodyear | | N/A | N/A | 313.0 | 350.3 | 402.7 | 441.3 | 493.0 | 510.2 | 541.2 |
| IF380/105R50 | Goodyear | | N/A | N/A | 380.6 | 441.3 | 493.0 | 555.0 | 606.7 | 627.4 | 665.3 |
| IF520/85R42 | Goodyear | | N/A | N/A | 479.2 | 541.2 | 606.7 | 682.6 | 737.7 | 786.0 | 806.7 |
| 480/80R42 | Goodyear | | N/A | 281.3 | 330.9 | 380.6 | 424.0 | 479.2 | 524.0 | 555.0 | 568.8 |
| VF380/90R46 | Michelin | | N/A | N/A | N/A | N/A | N/A | N/A | N/A | N/A | N/A |
| VF420/95R50 | Michelin | | N/A | N/A | N/A | N/A | N/A | N/A | N/A | 782.6 | 815.6 |
| VF480/80R50 | Michelin | | 358.5 | 430.2 | 502.6 | 505.4 | 646.0 | 726.0 | 805.3 | N/A | N/A |

| TIRE LOAD LIMITS (KG) AT VARIOUS COLD INFLATION PRESSURES (BAR) - CONTINUED | | | | | | | | | | | |
|---|-----------|-----------------|-------|-------|--------|--------|--------|--------|--------|-------|--|
| | | Inflation (bar) | 2.4 | 2.8 | 3.2 | 3.6 | 4.0 | 4.4 | 4.8 | 5.2 | |
| 650/65R38 | Alliance | | 770.1 | 842.5 | 911.5 | N/A | N/A | N/A | N/A | N/A | |
| IF380/90R46 | Alliance | | 536.4 | 587.4 | 639.1 | 674.3 | 712.2 | 774.3 | N/A | N/A | |
| IF480/80R50 | Alliance | | 732.2 | N/A | N/A | N/A | N/A | N/A | N/A | N/A | |
| 650/65R38 | Firestone | | 737.7 | 806.7 | N/A | N/A | N/A | N/A | N/A | N/A | |
| VF380/105R50 | Firestone | | 827.4 | 910.1 | 958.4 | 1048.0 | 1082.5 | 1179.0 | N/A | N/A | |
| 380/90R46 | Goodyear | | 493.0 | 541.2 | 589.5 | 627.4 | 665.3 | 723.9 | 786.0 | 827.4 | |
| IF320/105R54 | Goodyear | | 568.8 | 627.4 | 665.3 | N/A | 758.4 | 827.4 | N/A | N/A | |
| IF380/105R50 | Goodyear | | 703.3 | 786.0 | 827.4 | N/A | 937.7 | 1020.4 | 1110.1 | N/A | |
| IF520/85R42 | Goodyear | | 882.5 | N/A | N/A | N/A | N/A | N/A | N/A | N/A | |
| 480/80R42 | Goodyear | | 606.7 | 665.3 | 723.9 | 758.4 | 806.7 | N/A | N/A | N/A | |
| VF380/90R46 | Michelin | | 665.3 | 759.8 | 828.7 | 881.8 | 912.2 | 988.0 | N/A | N/A | |
| VF420/95R50 | Michelin | | 881.8 | 965.3 | 1048.7 | 1109.4 | N/A | N/A | N/A | N/A | |
| VF480/80R50 | Michelin | | N/A | N/A | N/A | N/A | N/A | N/A | N/A | N/A | |

NOTE: There are no adjustments to the loads and pressures in the above table for lower speeds or stationary service.

NOTE: Minimum inflation pressures for IF agricultural tires used as singles = .8 bar.



SECTION 2 – SAFETY AND PRECAUTIONS

INTENDED USE

NOTICE

This machine is designed for and intended to be used for the application of chemicals and fertilizers to field crops. Use in any other way or for any other purpose is considered misuse of this machine.

Most accidents occur as the result of failure to follow basic and fundamental safety rules and precautions. Recognizing potential safety hazards, following correct and safe operating procedures described in this manual, and complying with safety warnings located throughout the machine may reduce the risk of accidents.

There is no way to completely eliminate the potential for danger when operating agricultural equipment. Therefore, you must study this operator's manual and understand how to operate the sprayer controls for safe operation before using the sprayer, its attachment, or any sprayer equipment. Likewise, never let anyone operate the machine without proper instruction.

Do not operate the sprayer, its attachment, or any sprayer equipment for anything other than their intended uses. Hagie Manufacturing Company shall not be liable for any damage, injury, or death associated with improper use of the sprayer, its attachment, or any sprayer equipment.

Do not make any modifications such as, but not limited to, weldments, add-ons, adaptations, or changes from the original design of the sprayer. Such modifications may become safety hazards to you and others and **will void all warranties.**

Replace missing, faded, or damaged safety signs. Refer to "Safety Decals" elsewhere in this section for correct sign and placement.

SAFETY PRECAUTIONS

NOTE: If your machine is equipped with All Wheel Steer (AWS), pay special attention to components, operating instructions, and safety precautions marked with ^.

Do Not Bypass Safety Start

- Start the machine from the operator's seat only.
- The parking brake must be engaged before starting the engine.



Use Caution While Driving ^

- Never drive near ditches, embankments, holes, mounds, or other obstacles.
- Never drive on hills too steep for safe operation.



- Reduce machine speed before turning.



- Do not permit passengers to ride on the machine while it is moving. Failure to comply may result in passenger falling off of machine and/or obstructing the operator's view.



- Keep riders off machine. The only time a passenger should be permitted to ride inside the cab is for instructional or diagnostic purposes only. The passenger should be seated in the instructor seat next to the operator and never allowed to ride outside of the cab.
- Ensure there is adequate clearance before driving under any overhead obstructions. Contact with power lines may result in serious injury or death.



- Booms must be folded and in cradles when driving the machine on a roadway or when near power lines.

Remove Paint Before Welding or Heating

- Avoid toxic fumes and dust. Hazardous fumes can be generated when paint is heated by welding, soldering, or using a torch.



- Do not use chlorinated solvents in areas where welding will take place.
- Perform all work in an area that is well ventilated to carry toxic fumes and dust away.
- Dispose of paint and solvents properly.

Avoid Heating Near Pressurized Lines

- Avoid torching, welding, and soldering near pressurized hydraulic lines. Pressurized lines may accidentally burst when heat goes beyond the immediate flame area.



Handle Fuel Safely

- Always turn the engine off and allow it to cool before refueling.
- NEVER smoke while refueling.



- Do not fill tank completely, as fuel may expand and run over.
- Always clean up spilled fuel with soapy water.
- Keep a fire extinguisher nearby when refueling.

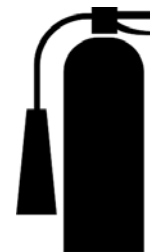

Operate Safely ^

- Before moving the machine, ensure there are no obstacles or persons in the path of travel.
- Never operate a machine in the same field as walking personnel.

- Always drive at a reasonable field speed.
- Never operate the machine on a roadway with solution in the tank. Additional weight caused from a full or partially full solution tank may cause erratic or increased stopping distance.
- Do not operate the machine at speeds exceeding 20 mph (32 km/h) with solution in the tank. Operating speeds exceeding 20 mph (32 km/h) with a fully loaded tank may result in tire blow-out or wheel hub damage and will void the warranty.
- Ensure the Slow Moving Vehicle (SMV) emblem and the Speed Indicator Symbol (SIS) are in place and visible from the rear of machine when traveling on public roadways.



- Pull over to the side of the road before stopping.
- Always come to a complete stop before reversing directions.
- Ensure the back-up alarm is audible when operating the machine in reverse.
- Keep a fire extinguisher nearby at all times.
- Keep ALL shields in place.
- Keep clear of all moving parts and keep others away while operating (including the reversible fan).
- Do not activate the parking brake while the machine is in motion.
- Bring machine to a gradual stop to avoid sudden downward decent.
- Reduce speed for icy, wet, graveled, or soft roadway surfaces.
- Use flashers/hazard warning lights (day or night) unless prohibited by law.
- Keep away from overhead power lines. Serious injury or death may result to you or others should the machine come into contact with electrical power lines.

- Never use starting fluid to assist engine start-up.
- If your machine is equipped with ground speed sensing radar or light sensing depth units, do NOT look directly into radar beam, as it emits a very low intensity microwave signal, which may result in possible eye damage.

Be Prepared

- Be prepared for an emergency. Keep a fire extinguisher, first aid kit, and clean water in the cab at all times.
- Service the fire extinguisher regularly.
- Keep an accurate inventory of supplies in the first aid kit and dispose of any item(s) that have expired.

Wear Protective Clothing

- Do not wear loose fitting clothing that could get caught in moving parts. Wear safety equipment that is appropriate for the job.



- Do not store chemical-soaked clothing in the cab. Clean off as much mud and dirt from your shoes as you can before entering the cab.

Protect Against Noise

- Wear suitable hearing protection. Prolonged exposure to loud noise may result in loss of hearing.



Battery Acid Accident Prevention

Avoid serious injury by avoiding battery acid contact with your body. Battery electrolyte contains sulfuric acid that is strong enough to eat holes in clothing and cause blindness if splashed into eyes.

Make sure to:

- Fill batteries in a well ventilated area.
- Wear Personal Protective Equipment (PPE) when servicing a battery.
- Avoid inhaling of fumes when recharging with electrolyte.
- Avoid spilling or dripping electrolyte.
- When charging a battery, connect positive cable to positive terminal and negative cable to negative terminal. Failure to comply may result in an explosion and/or personal injury.

If you spill on yourself:

- Flush affected area with cold water and remove contaminated clothing immediately. Continue to flush the area for a minimum of 15 minutes.



- Call a physician.
- While transporting or waiting for medical attention, apply compresses of iced water or immerse affected area in iced water. **DO NOT ALLOW SKIN TISSUE TO FREEZE.**
- Do not apply creams or ointments until you have been seen by a physician.

If acid is swallowed:

- Do NOT induce vomiting.
- Drink large amounts of water.
- Seek medical attention immediately!
- Do not neutralize the acid.

If fumes are inhaled:

- Move the person into fresh air.
- Do not give artificial respiration to a person that is able to breath on their own.
- Give CPR only if there is no breathing and no pulse.
- Seek medical attention immediately!

Handle Agricultural Chemicals Safely

Agricultural chemicals used in applications can be harmful to your health and the environment if not used properly.

- Always follow the manufacturer's label for directions of use.
- Never allow chemicals to come in contact with your skin or eyes. Always use the proper Personal Protective Equipment (PPE).
- Never pour chemicals into an empty solution tank. Always fill tank half full of water first.
- Dispose of empty chemical containers properly.



- Wash spilled chemicals or spray residue from the sprayer to prevent corrosion and deterioration.
- Select safe areas to fill, flush, calibrate, and clean the sprayer where chemicals will not run off to contaminate people, animals, vegetation, or water supply.
- Never place a spray tip/nozzle to your mouth in an attempt to unplug it.
- Do not spray when wind is in excess of chemical manufacturer's recommendation.
- Store chemicals in their original containers with the label intact.
- Store chemicals in a separate, locked building.

- Wear Personal Protective Equipment (PPE) as recommended by the chemical manufacturer.

Safe Hydraulic Maintenance

- Always practice personal safety when performing service or maintenance on the hydraulic system.
- Use caution when working around hydraulic fluid under pressure. Escaping fluid can have sufficient force to penetrate your skin, possibly resulting in serious injury. This fluid may also be hot enough to burn.

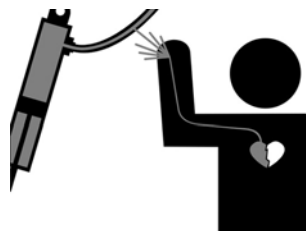

- Always lower the load or relieve the pressure before repairing a hydraulic oil leak.

Beware of Exhaust Fumes

- Never run the machine in an enclosed area. Proper ventilation is required. Use an exhaust pipe extension to remove fumes if you must operate inside a building. Also, open doors and windows to bring in enough outside air into the area.

General Maintenance Safety

- Turn off engine before checking, adjusting, repairing, lubricating, or cleaning any part of the sprayer.
- Remove all chemical residue from the work area before performing service/maintenance.
- When servicing the radiator, allow engine to cool before removing the pressurized cap.



- Disconnect battery ground cable and turn the Battery Disconnect Switch OFF before servicing the electrical system or welding on the machine.



- Machines equipped with All Wheel Steer (AWS) have position sensing internal to the steering cylinders. Disconnect each sensor before welding on the machine. ^

Spray Booms

- Select a safe area before unfolding/folding the booms.
- Clear area of personnel.
- Cradle booms when leaving the sprayer unattended.
- Ensure booms are folded when cradled.
- Do not unfold boom extension when main boom is in the cradle.
- Do not operate the sprayer with one boom wing out of cradle and other boom wing in cradle.
- Check for overhead obstructions.
- Do not unfold or fold booms near power lines. **Contact with power lines can result in serious injury or death.** A warning message will appear on the Machine Display before extending the outer boom extensions or when operating in Auto Fold. Press ACKNOWLEDGE showing that you have acknowledged that there are no overhead power lines or obstructions before proceeding.



120/132' Spray Booms

Before initial use, install provided boom hose rings before unfolding the boom. Failure to comply may result in property damage.

Refer to “Spray Boom Hose Ring Installation” provided in the *Spray Systems Section* elsewhere in this manual for further information.

Cold Oil Scenarios

- If the oil temperature is less than 50°F, the operator may experience control loss on the 90-ft. and 100-ft. fold cylinders. These cylinders are the main cylinders affected by over-running loads due to the weight rotation of the boom during unfold/fold situations.

When the oil is cold, the valve response is not as fast or accurate. Therefore, when having to lift the weight, the cylinder will move slower, but in trying to suspend the weight, the weight may cause faster movement, as the valve is not dampening the flow like it normally would.

NOTE: This situation requires the operator to ensure no one is near the boom during operation.

Tread Adjust

- Transport machine at narrowest tread adjust setting only.

All Wheel Steer (AWS) Safety ^

–If Equipped

Many of the following precautions are repetitious to the precautions for a standard machine. It is imperative they receive special consideration. Failure to comply with the AWS safety precautions and operating instructions may result in property damage, serious injury, or death.

- Become familiar with and understand how to operate your machine in conventional steering mode before operating with AWS.
- Understand AWS system components, operating procedures, and system limitations before operating.

- Reduce machine speed before turning.
- Never drive on hills too steep for safe operation.
- Never drive near ditches, embankments, holes, mounds, or other obstacles.
- Come to a complete stop before reversing directions.
- Always drive at a reasonable field speed.

SEAT BELT

For your safety, wear seat belt at all times when operating the machine.

Seat Belt Operation

- Grasp the Seat Belt Buckle (located on the outward side of seat) and extend all the way across your hips, seated below your abdomen.
- Insert the buckle tongue into the receptacle assembly (located on the opposite side of seat) and engage into LOCKED position.
- **To release Seat Belt**, press the Release Button (located on the receptacle end) and allow belt to retract.

Inspection/Replacement

Inspect seat belt and mounting hardware yearly. Replace seat belt if anchorage system, buckle, belt, or retractor shows signs of damage, including evidence of cuts, fraying or wear, discoloration, or being heavily soiled - especially with oil grease or fuel. Replace only with replacement parts approved for your machine.

ROTATING BEACON

The Rotating Beacon (located on the front roof cap) is used for increased visibility to others. The beacon will illuminate when the Hazard/Warning Lights Switch (located on the steering column) is activated.

NOTE: The Rotating Beacon is active in both Road and Field mode. The Hazard/Warning Lights are active in Road mode only.



Rotating Beacon
(Located on front roof cap)
-Typical View



E-Stop Switch
(Located on the side console)
-Typical View

EMERGENCY STOP (E-Stop)

NOTICE

Do not use the E-Stop Switch for non-emergency stopping or as a parking brake.

The E-Stop Switch (located on the side console) provides a quick and positive method for stopping the engine in an emergency situation.

When the E-Stop Switch is depressed, it locks in position and removes the ignition signal to shut down the engine. To reset the E-Stop Switch, turn the switch in the direction of the arrows (located on the face of the button).

When the E-Stop Switch is activated, a message will appear on the Machine Display to alert the operator that the E-Stop is engaged. Press OK to acknowledge.



E-Stop Active Message
(Located on the Machine Display)

EMERGENCY EXIT

CAUTION

Do not look directly at the glass when using the Emergency Exit Tool. Failure to comply may result in personal injury.

NOTICE

The Emergency Exit Tool is a permanent fixture of the machine. Do not remove from cab under any circumstances.

In the event of an emergency, use the cab door to exit the machine. Should the cab door become inoperable, an Emergency Exit Tool (located along the rear right-hand side of cab) is provided and is used in the rare event to shatter the glass of the cab.

- Using the metal end of the Emergency Exit Tool, repeatedly strike the glass to shatter.



Emergency Exit Tool
(Located along rear right-hand side of cab)
-Typical View

Should the need arise to escape from a seat belt that may become inoperable, use the “hook end” of the Emergency Exit Tool to cut the seat belt.

FIRE EXTINGUISHER

Your machine is equipped with a Fire Extinguisher (located along platform on the left-hand side of machine). In the event that

use of the Fire Extinguisher is required, follow the manufacturer’s operating instructions provided on the Fire Extinguisher.

To Remove Fire Extinguisher

- Pull the Security Latch OUTWARD to disengage and remove Fire Extinguisher.



Fire Extinguisher
(Located along platform on left-hand side of machine)
-Typical View

Inspection and Replacement

Follow the manufacturer’s recommendations on inspection and replacement.

FIRST AID KIT

-If Equipped

A First Aid Kit (located beneath the operator’s seat) is provided for your convenience.

NOTE: Keep an accurate inventory of supplies in the First Aid Kit and dispose of any item(s) that have expired.



First Aid Kit
(Located beneath the operator's seat)
-Typical View

machine, solution, and attachment) allowed to be compliant with ROPS testing.

NOTICE

The addition of optional equipment on your machine may increase the ROPS maximum overall weight. If this weight exceeds the vehicle test weight, the ROPS becomes non-compliant.

ROLL-OVER PROTECTION STRUCTURE (ROPS)

The cab on your machine is featured with a Roll-Over Protection Structure (ROPS), which is intended to protect the operator from injuries caused by machine rollovers.

The following ROPS certification decal (located inside cab on the rear right-hand b-post) indicates that your cab has met specific testing requirements and is compliant with Occupational Safety and Health Administration (OSHA) and International Organization for Standardization (ISO) regulations.

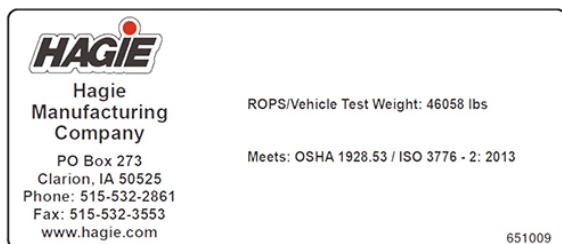

ROPS Certification Decal
(Located inside cab on
the rear right-hand b-post)

NOTE: *The ROPS/Vehicle Test Weight listed on the certification decal is the maximum overall weight (including*

ROPS Inspection Guide

ROPS, like any other safety device, need to be periodically inspected to verify that the integrity of the device has not been compromised through normal machine use, misuse, age degradation, modifications, or roll-overs.

Some mechanical discretion is essential. Therefore, personnel who inspect ROPS need to comprehend and understand the significance of issues like - if in doubt, remove the machine from service and contact the ROPS manufacturer for assistance. Certain conditions will absolutely render the ROPS unusable. Such examples are:

- Permanent deformation or twisting
- Missing, damaged, or loose mounting hardware
- Heavily weathered or torn rubber isolators
- Mounting hardware that is of a grade lesser than specified
- Any cracks in the structure (structural members and/or welds)
- Significant corrosion
- Modifications (i.e. unauthorized welds and or/holes)
- Missing or unreadable ROPS label
- Applicable ROPS machine model not specified on the ROPS label
- Missing seat belts
- Any unauthorized repair
- Incomplete/improper installation

Other conditions may require imminent service, but may not render the unit immediately unusable. Such examples are:

- Faded paint
- Slightly weathered isolators
- Faded, hard to read ROPS label
- Significantly corroded mounting hardware

ROPS must be inspected immediately after any type of collision, roll-over, or impact. If any damage is evident, the ROPS must be removed from service, repaired, and/or replaced.

When a ROPS is removed or reinstalled, mounting hardware must be examined for signs of over-stressing. Damaged mounting hardware must be replaced with proper specification hardware before placing the ROPS back in service.

Properly maintained seat belts are essential to compliment the operator crush protection designed into the ROPS. All seat belt and/or seat belt anchorage systems that show evidence of cuts, fraying or wear, significant discolorations due to exposure to the elements, heavily soiled - especially with oil grease or fuel, or any type of damage must be immediately replaced, regardless of age.

Operators are to be instructed to properly adjust and use seat belts at all times.

To replace safety decals, ensure the installation area is clean and dry and decide on exact position before you remove the backing paper.

Safety Decal Locations

650114

(Located on rinse tank lid)

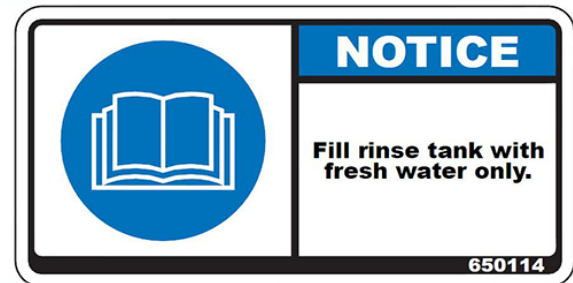

N408864

(Located near hand wash tank)



SAFETY DECALS

Decals warning you of avoidable danger are located on various parts of the machine and attachment. They are there for your personal safety and protection. DO NOT remove them. They will fracture upon attempted removal and therefore, must be replaced.

Following are locations of important safety decals. Replace them if they are damaged or missing. All safety decals, instructional decals, or machine striping may be purchased through your local John Deere dealer.

N403721
(Located on inner right-hand side of ladder)



N303688
(Located on rear right-hand cab post)



H228964
(Located near surge tank)



650178
(2) - Located near each quick-tach lock pin assembly

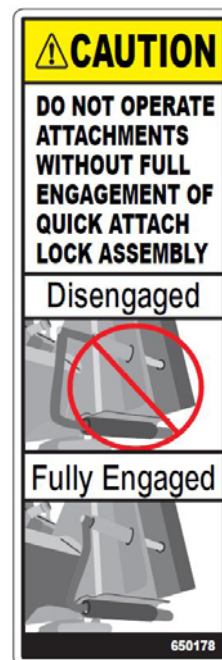

L212136
(4) - Located near each lifting point
containment ring



RISK OF INJURY DUE TO IMPROPER LIFTING.
DO NOT ATTEMPT TO LIFT MACHINE
WITHOUT JACKS PROPERLY SEATED IN THE
LIFTING POINT CONTAINMENT RINGS.

651002
(Located near the battery disconnect
switch)

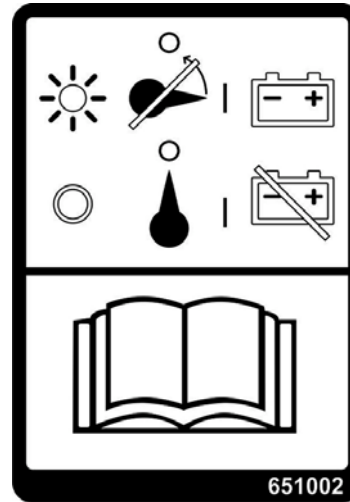

DO NOT TURN BATTERY DISCONNECT
SWITCH OFF WHEN FINAL TIER 4
INDICATOR LIGHT IS ILLUMINATED

650516
(1) - Located near front fill
(1) - Located near side fill

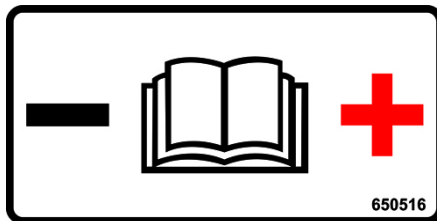

Negative Terminal Positive Terminal

650493
(Located near hydraulic oil reservoir
sight gauge)

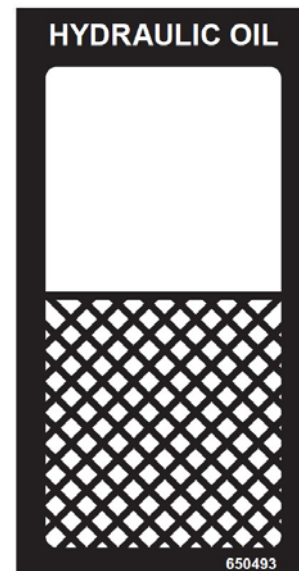

HYDRAULIC OIL RESERVOIR LEVEL

650517
(Located near battery disconnect
switch)

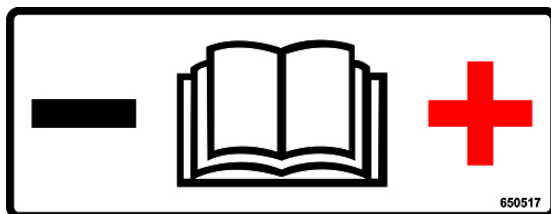

Negative Terminal Positive Terminal

HXE28534
(1) - Located on front left-hand cross
member near quick connect multi-

coupler

(1) - Located on right-hand cross member beneath cab



N404969

(1) - Located near main air tank
(1) - Located near air purge air tank (if equipped)



N209334

(1) - Located near main air tank
(1) - Located near air purge air tank (if equipped)



N401323

(Located near fuel fill ladder)

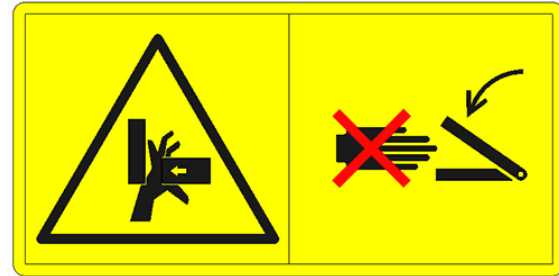

PINCH/CRUSH HAZARD

Keep hands and fingers
away from pinch/pivot areas

650431

(Located near fuel fill - Final Tier 4 engines only)



T188283

(Located near reversible fan)



N204628
(Located on front left-hand cab post)



HXE19558
(Located on inner right-hand side of ladder)



N404968
(1) - Located near solution tank lid
(1) - Located near Dual Product solution tank lid (*if equipped*)



N203265
(1) - Located near solution tank lid
(1) - Located near Dual Product solution tank lid (*if equipped*)
(1) - Located on side-fill inductor tank lid



90/100' Boom Decals

HXE28534

(Located on inside of transom)



650204

(6) - Located near each fold point



650204

(4) - Located near each fold point



650210

(5) - Located on each NORAC sensor



650210

(3) - Located on each NORAC® sensor



120/132' Boom Decals

HXE28534

(Located on inside of fixed transom)



SEAT - OPERATOR

- (A) - Armrest Height Adjuster
- (B) - Armrest Tilt Dial
- (C) - Fore/Aft Isolation Lever
- (D) - Recline Lever
- (E) - Slide Release Lever
- (F) - Thigh Tilt Lever
- (G) - Height Adjustment Lever
- (H) - Thigh Extension Lever

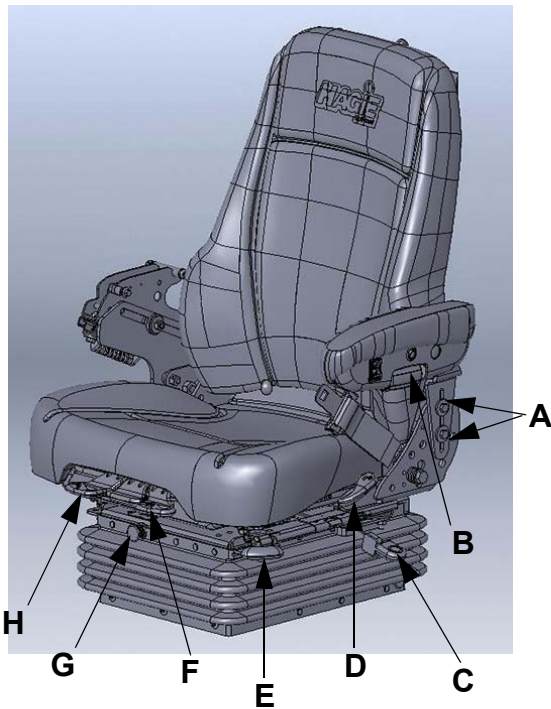

- (I) - Armrest Height/Length Adjuster
- (J) - Lumbar Knob
- (K) - Document Pouch

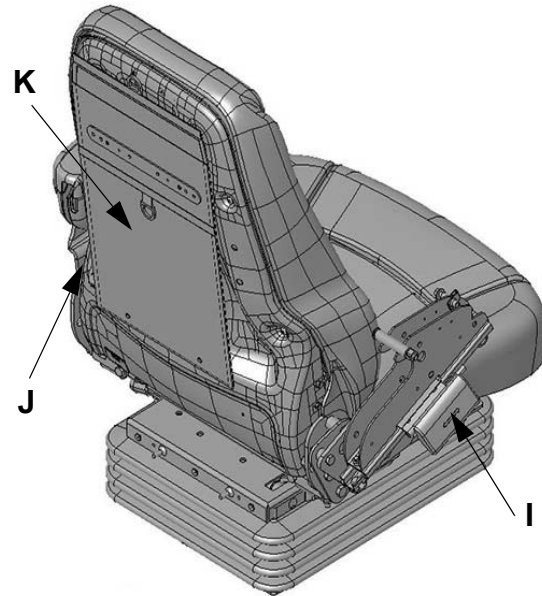

Armrest Height Adjuster (A)

(Adjusts armrest height)

- Loosen two (2) bolts and move armrests up or down.
- While maintaining desired armrest position, re-tighten bolts.

Armrest Tilt Dial (B)

(Tilts armrests)

- Roll Armrest Tilt Dial (located on side of operator's seat) INWARD (towards operator) to tilt armrest DOWN.
- Roll Armrest Tilt Dial OUTWARD (away from operator) to tilt armrest UP.

Fore/Aft Isolation Lever (C)

(Locks or unlocks fore/aft isolation)

- Pull Fore/Aft Isolation Lever UP to unlock isolation.
- Push Fore/Aft Isolation Lever DOWN to lock isolation.

Recline Lever (D)

(Angles back rest cushion)

- Pull and hold Recline Lever UP to adjust back rest angle. Release lever when desired angle is achieved.

Slide Release Lever (E)

(Moves top of seat fore/aft)

- Pull and hold Slide Release Lever while sliding seat forward or rearward. Release lever when desired position is achieved.

Thigh Tilt Lever (F)

(Tilts seat cushion up and down)

- Pull Thigh Tilt Lever UP and hold cushion to adjust + 4 degrees. Release lever when desired position is achieved.
- Pull Thigh Tilt Lever UP and push cushion down to adjust -4 degrees. Release lever when desired position is achieved.

Height Adjustment Lever (G)

(Moves seat up and down)

- Push Height Adjustment Lever IN to increase seat height.
- Pull Height Adjustment Lever OUT to decrease seat height.

Thigh Extension Lever (H)

(Extends seat cushion fore/aft)

- Pull Thigh Extension Lever UP and hold to adjust cushion +/- 30 mm. Release lever when desired position is achieved.

Armrest Height/Length Adjuster (I)

(Adjusts height and length of armrest)

- Pull and hold Armrest Height/Length Adjuster and slide forward or rearward. Release adjuster when armrest is in desired position.

Lumbar Knob (J)

(Adjusts lumbar curvature)

- Rotate Lumbar Knob INWARD (toward operator) for increased curve.
- Rotate Lumbar Knob OUTWARD (away from operator) for decreased curve.

Document Pouch (K)

(Storage for various machine manuals)

- Pull Document Pouch Fastener to OPEN.
- Push Document Pouch Fastener to CLOSE.

Seat Belt

Refer to “Seat Belt” provided in the *Safety and Precautions Section* elsewhere in this manual for further information.

SEAT - OPERATOR (PREMIUM)

-If Equipped

Your machine may be equipped with a Premium Air Ride Operator’s Seat that is equipped with the following features for your driving and comfort needs.

- (A) - Headrest
- (B) - Heat/Cool Selector Switch
- (C) - Heat/Cool Temperature Switch
- (D) - Armrest Tilt Dial
- (E) - Height Adjustment Switch
- (F) - Recline Lever
- (G) - Slide Release Lever
- (H) - Thigh Tilt Lever
- (I) - Thigh Extension Lever

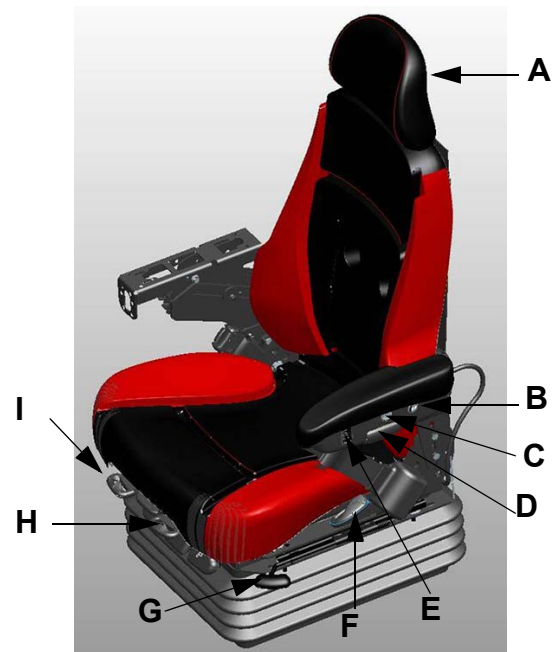

- (J) - Armrest Height Adjuster
- (K) - Fore/Aft Lockout Isolator
- (L) - Lateral Lockout Isolator
- (M) - Ride Firmness Lever



- (N) - Armrest Height/Length Adjuster
- (O) - Lumbar Knob
- (P) - Document Pouch

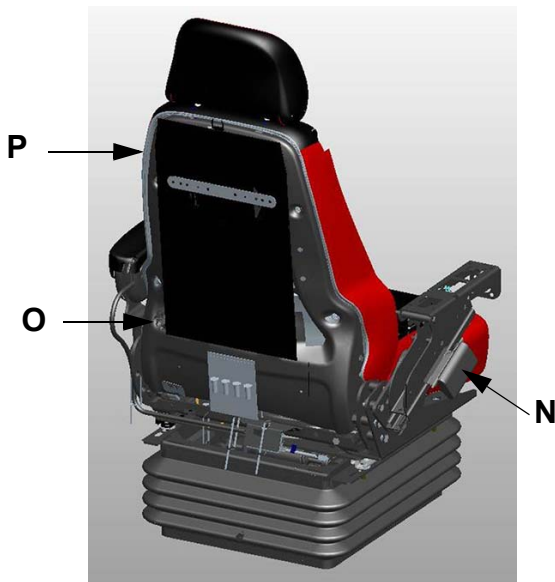

Headrest (A)

(Adjusts height and tilt)

- Firmly grasp headrest and pull UP for higher adjustment.
- Firmly grasp headrest and push DOWN for lower adjustment.

Tilt:

(**First Position:** hold and rotate down 10-degrees; **Second Position:** hold and rotate down 20-degrees; **Third Position:** hold and rotate down 30-degrees. Hold and rotate down to return Headrest to 0-degree position).

Heat/Cool Selector Switch (B)

(Selects between heat and cool settings)

- Press Heat/Cool Selector Switch FORWARD to cool.
- Press Heat/Cool Selector Switch REARWARD to heat.

Heat/Cool Temperature Switch (C)

(Switches heat/cool temperature to high, low, or off settings)

- Press Heat/Cool Temperature Switch UP for HIGH heat or cool.
- Press Heat/Cool Temperature Switch DOWN for LOW heat or cool.
- Press Heat/Cool Temperature Switch to the MID position to turn OFF.

Armrest Tilt Dial (D)

(Tilts armrests)

- Roll Armrest Tilt Dial (located on each side of operator's seat) INWARD (towards operator) to tilt armrest DOWN.
- Roll Armrest Tilt Dial OUTWARD (away from operator) to tilt armrest UP.

Height Adjustment Switch (E)

(Moves seat up and down)

- Press Height Adjustment Switch UP to increase seat height.
- Press Height Adjustment Switch DOWN to decrease seat height.

Recline Lever (F)

(Angles back rest cushion)

- Pull and hold Recline Lever UP to adjust back rest angle. Release lever when desired angle is achieved.

Slide Release Lever (G)

(Moves top of seat fore/aft)

- Pull and hold Slide Release Lever while sliding seat forward or rearward. Release lever when desired position is achieved.

Thigh Tilt Lever (H)

(Tilts seat cushion up and down)

- Pull Thigh Tilt Lever UP and hold cushion to adjust +4 degrees. Release lever when desired position is achieved.
- Pull Thigh Tilt Lever UP and push cushion down to adjust -4 degrees. Release lever when desired position is achieved.

Thigh Extension Lever (I)

(Extends seat cushion fore/aft)

- Pull Thigh Extension Lever UP and hold to adjust cushion +/- 30 mm. Release lever when desired position is achieved.

Armrest Height Adjuster (J)

(Adjusts armrest height)

- Loosen two (2) bolts and move armrests up or down.
- While maintaining desired armrest position, re-tighten bolts.

Fore/Aft Lockout Isolator (K)

(Locks or unlocks fore/aft isolation)

- Pull Fore/Aft Lockout Isolator UP to unlock isolation.
- Push Fore/Aft Lockout Isolator DOWN to lock isolation.

Lateral Lockout Isolator (L)

(Locks or unlocks lateral isolation)

- Pull Lateral Lockout Isolator UP to lock isolation.
- Push Lateral Lockout Isolator DOWN to unlock isolation.

Ride Firmness Lever (M)

(Adjusts ride suspension)

- Pull Ride Firmness Lever UP for a firmer ride.
- Push Ride Firmness Lever DOWN for a softer ride.

Armrest Height/Length Adjuster (N)

(Adjusts height and length of armrest)

- Pull and hold Armrest Height/Length Adjuster and slide forward or rearward. Release adjuster when armrest is in desired position.

Fore/Aft Adjustment: +/- 76 mm at 12.7 mm increments; **Up/Down Adjustment** +/- 35 mm at 5.4 mm increments.

NOTE: Armrest tilt fixed position = 25 degrees.

Lumbar Knob (O)

(Adjusts lumbar curvature)

- Rotate Lumbar Knob INWARD (toward operator) for increased curve.
- Rotate Lumbar Knob OUTWARD (away from operator) for decreased curve.

Document Pouch (P)

(Storage for various machine manuals)

- Pull Document Pouch Fastener to OPEN.
- Push Document Pouch Fastener to CLOSE.

Seat Belt

Refer to “Seat Belt” provided in the *Safety and Precautions Section* elsewhere in this manual for further information.

SEAT - INSTRUCTOR

The cab area is featured with an Instructor Seat to allow an instructor/trainer to be seated and instruct on how to operate the machine.



Instructor Seat
-Typical View

A storage compartment and cup holders are located beneath the Instructor Seat for your convenience. Lift hinged seat to access.



-Typical View

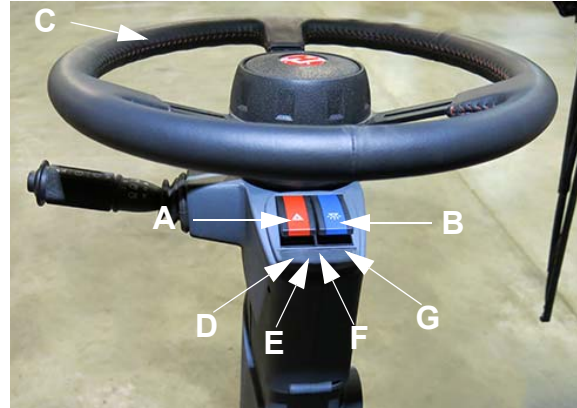

-Typical View

OPERATOR'S STATION

Front Console

- (A) - Hazard/Warning Lights Switch
- (B) - Highway/Running Lights Switch
- (C) - Steering Wheel
- (D) - Turn Signal Indicator (Left)
- (E) - Highway Running Lights Indicator
- (F) - High Beams Indicator
- (G) - Turn Signal Indicator (Right)
- (H) - Steering Wheel Telescope Adjust Handle
- (I) - Steering Column Tilt Adjust Button (Knee Angle)
- (J) - Steering Column Release Pedal
- (K) - Deceleration (Decel) Pedal
- (L) - Operator Foot Pegs (2)
- (M) - Horn
- (N) - Windshield Washer
- (O) - Turn Signal Lever
- (P) - Windshield Wiper Speed
- (Q) - High Beams (Brights)



-Typical View



-Typical View

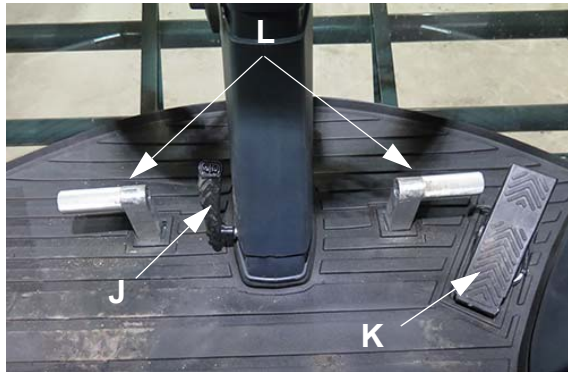

-Typical View



-Typical View

Hazard/Warning Lights Switch

The Hazard/Warning Lights (located on the front and rear of machine) are to be used at any time, day or night, that you are traveling on a public roadway, unless prohibited by law.

NOTE: The machine's drive state must be in Road Mode to activate the Hazard/Warning Lights.

NOTE: The Hazard/Warning Lights are tied to battery power and will operate when the machine is off. The flashers are disabled in Field Mode.

NOTE: The Hazard/Warning Light Flashers are also activated with the corresponding turn signal.

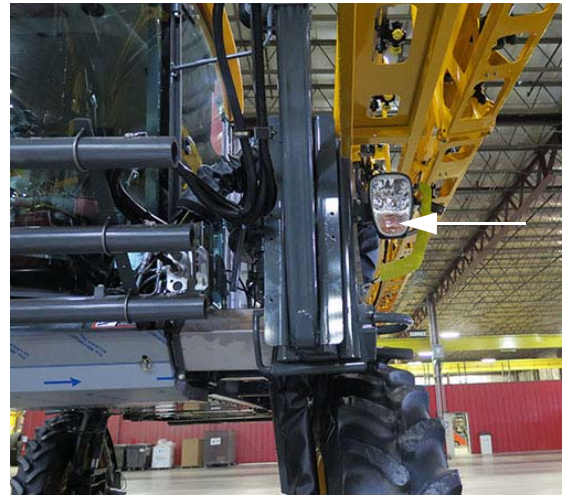

Front Hazard/Warning Light Flashers (2)
-Typical View



Rear Hazard/Warning Light Flashers (4)
-Typical View

To activate the Hazard/Warning Lights:

- Press the Hazard/Warning Lights Switch (located on steering column) in the DOWN (On) position to activate.
- Press the Hazard/Warning Lights Switch in the UP (Off) position to deactivate.

NOTE: The Rotating Beacons (located on each side of cab roof) also become active when the Hazard/Warning Lights Switch is depressed. Refer to "Rotating Beacons" provided in the Safety and Precautions Section elsewhere in this manual for further information.



Hazard/Warning Lights Switch
(Located on steering column)
-Typical View



Rear Taillights (2)
-Typical View

Highway Running Lights Switch (Headlights)

The Highway Running Lights (located on the front and rear of machine) are to be used when traveling on a public roadway at night.

NOTE: The Highway Running Lights operate in both Road and Field Mode.

To activate the Highway Running Lights:

- Press the Highway Running Lights Switch (located on steering column) in the DOWN (On) position to activate.
- Press the Highway Running Lights Switch in the UP (Off) position to deactivate.

NOTE: The Highway Running Lights Indicator (located near the steering wheel) will illuminate when activated.

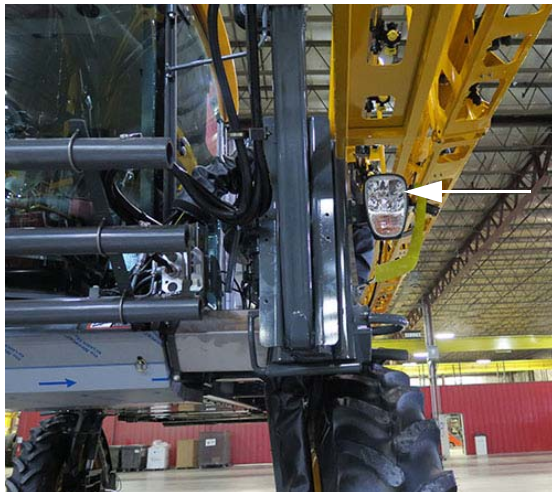

Highway Running Lights (2)
-Typical View



Highway Running Lights Switch
(Located on steering column)
-Typical View

The two rear red taillights are activated any time that the headlights are on.

NOTE: Highway Running Lights are enabled when the key is in the ON position. However, prolonged use of these lights without the engine running is not recommended.

Steering Wheel Telescope Adjust

The Steering Wheel Telescope Adjust allows movement of the upper portion of the steering column to best suit your driving needs.

- To adjust the steering wheel, lift the Steering Wheel Telescope Adjust Handle (located on the right-hand side of the steering column) UP to loosen enough to freely move the steering wheel.



Steering Wheel Telescope Adjust Handle
(Located on the right-hand
side of steering column)
-Typical View

- With the handle loosened, adjust steering wheel to desired position. While holding the wheel in position, release the Steering Wheel Telescope Adjust Handle to lock into place.

Steering Column Tilt Adjust (Knee Angle)

The Steering Column Tilt Adjust allows you to angle the top section of the steering column to the position that best suits your comfort needs.

To tilt top section of steering column down:

- Lift and hold the Steering Column Tilt Adjust Button (located on the left-hand side of the steering column) in the UP position.



Steering Column Tilt Adjust Button
(Located on the left-hand
side of the steering column)
-Typical View

- While maintaining the Steering Column Tilt Adjust Button in the upward position, pull steering wheel BACKWARD (toward the operator).
- Release button when steering column is in the desired position.

To tilt top section of steering column up:

- Lift and hold the Steering Column Tilt Adjust Button (located on the left-hand side of the steering column) in the UP position.
- While maintaining the Steering Column Tilt Adjust Button in the upward position, allow steering wheel to move FORWARD (away from the operator).
- Release button when steering column is in the desired position.

Steering Column Release Pedal

⚠ CAUTION

Ensure the steering wheel and steering column are in the locked position before attempting to operate the machine. Failure to comply may result in difficulty maintaining control of the machine.

The Steering Column Release Pedal is featured for ease of exiting and entering the cab.

- With your foot on the Steering Column Release Pedal (located on the lower left-hand side of the steering column), push pedal **DOWN** and move the steering column to desired position.



Steering Column Release Pedal
(Located on the lower left-hand side of the steering column)
-Typical View

- To lock the steering column in desired position, remove your foot from the Steering Column Release Pedal while holding the steering column in place.
- Once the steering column has engaged into locked position, firmly move the steering column in either direction to ensure security.

Operator Foot Pegs

-If Equipped

Operator Foot Pegs are located on each side of the steering column to provide added comfort and stability while operating the machine.



Operator Foot Pegs
(Located on each side of the steering column)
-Typical View

Deceleration (Decel) Pedal

⚠ CAUTION

The Decel Pedal is **NOT** a brake. It is designated for speed reduction only.

When nearing an end row and speed deceleration is desired, press the Decel Pedal (located to the lower right-hand side of the steering column) to decrease speed.



Decel Pedal
(Located to the lower right-hand
side of the steering column)
-Typical View

Refer to “Machine Display” provided elsewhere in this section for information on adjusting Decel Pedal minimum speed.

Horn

The Horn is sounded by pressing the Horn Button (located on the end of the turn signal lever) INWARD.



Horn Button
(Located on the end of
the turn signal lever)
-Typical View

Windshield Washer

The Windshield Washer Button is located on the end of the turn signal lever. To apply washer fluid, press and hold button in the IN position. Release button when desired amount of fluid is dispensed.

NOTE: Ensure there is adequate amount of washer fluid in the windshield washer fluid reservoir (located behind the left-hand side of cab) before operating.



Windshield Washer Button
(Located on the end of
the turn signal lever)
-Typical View

Windshield Wiper Speed

To increase or decrease Windshield Wiper speed, rotate the turn signal lever forward or backward to achieve Hi, Low, or Intermittent wiper speed.



Windshield Wiper Speeds
(Located on the turn signal lever)
-Typical View

Turn Signals

To activate the front and rear Turn Signals, move the Turn Signal Lever (located on the left-hand side of the steering column) FORWARD (away from operator) to signal a right turn, or BACKWARD (toward operator) to signal a left turn.

NOTE: The machine’s drive state must be in Road Mode to activate the Turn Signals.



Turn Signal Lever
-Typical View

NOTE: Steering column-mounted and Machine Display indicator lights will flash correspondingly when either turn signal is activated.

High Beams (Brights)

- To turn the High Beams ON, push the turn signal lever (located on the left-hand side of the steering column) DOWN.
- To turn the High Beams OFF, push the turn signal lever UP.

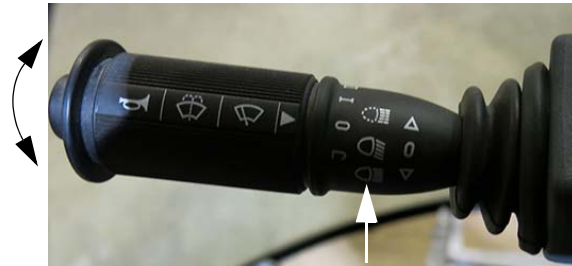

High Beams
(Located on the turn signal lever)
-Typical View

Side Console

- (A) - Emergency Stop Switch
- (B) - Foam Marker Switch (if equipped)
- (C) - Rinse Switch
- (D) - Boom Solution Valve Switches
- (E) - Fence Row Switch (Left)
- (F) - Rate Control Switches
- (G) - Rear Nozzle Switch
- (H) - Pump Speed/Rate Switches
- (I) - Fence Row Switch (Right)
- (J) - Main Tank Valve Switch
- (K) - Solution Pump Switch
- (L) - Agitation Valve Switch
- (M) - Boom Extension Switches (Left/Right Outer Fold)

- (N) - Ignition Switch
- (O) - Power Mirror Switch (if equipped)
- (P) - Hydrostatic Drive Control Handle
- (Q) - Transom Switch (Up/Down)
- (R) - Left-Hand Boom Switch
- (S) - Right-Hand Boom Switch
- (T) - Master Spray Switch
- (U) - End Row Management Switch
- (V) - Shift Up Switch
- (W) - Shift Down Switch
- (X) - Parking Brake Switch
- (Y) - Throttle Switch
- (Z) - Remote Stereo Controls
- (AA) - 12V Power Ports
- (BB) - Auxiliary 2 Audio Input Connection



-Typical View

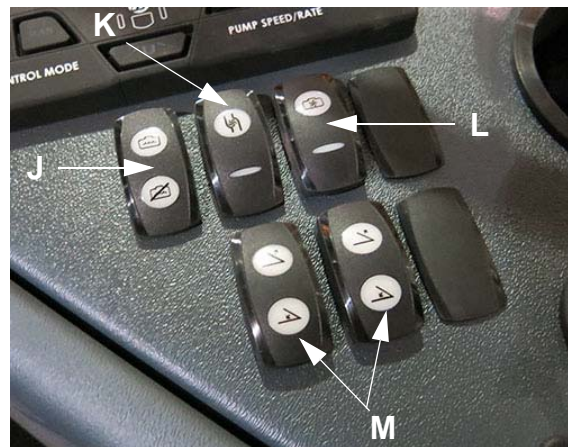

-Typical View



-Typical View



-Typical View

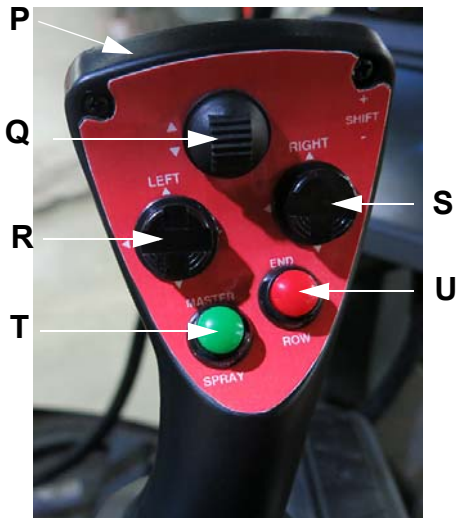

-Typical View



-Typical View



-Typical View

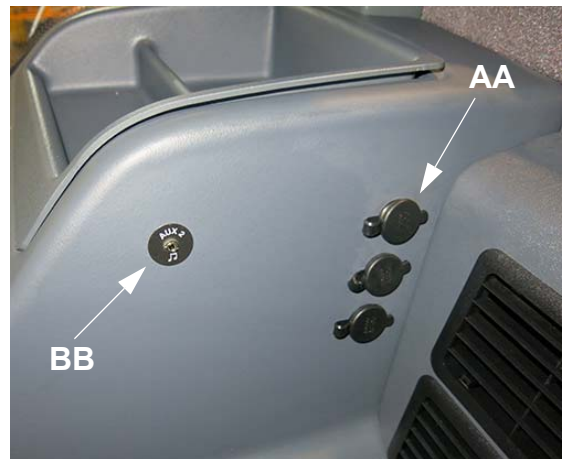

-Typical View

Emergency Stop (E-Stop)

The E-Stop Switch (located on the side console) provides a quick and positive method for stopping the engine in an emergency situation.

NOTICE

Do not use the E-Stop Switch for non-emergency stopping or as a parking brake.



E-Stop Switch
(Located on the side console)
-Typical View

Refer to “Emergency Stop” provided in the *Safety and Precautions Section* elsewhere in this manual for further information.

Foam Marker Switch

- If Equipped

The Foam Marker Switch (located on the side console) controls foam application on both sides of the machine.



Foam Marker Switch
(Located on the side console)
-Typical View

Refer to “Foam Marker” provided in the *Spray Systems Section* elsewhere in this manual for further information.

Rinse Switch

The Rinse Switch (located on the side console) is used to rinse the solution tank and spray booms.

NOTE: When rinsing the boom and nozzles, ensure the Boom Solution Valve Switches (located on the side console) are in the ON position before activating the Rinse Switch.



Rinse Switch
(Located on the side console)
-Typical View

Refer to “Rinse System” provided in the *Spray Systems Section* elsewhere in this manual for further information.

Boom Solution Valve Switches

The Boom Solution Valve Switches (located on the side console) each control a valve located on the boom or transom. The valves control the flow of the solution through the boom.



Boom Solution Valve Switches
(Located on the side console)
-Typical View

The boom is divided into sections, with the far left tip being the beginning of the first section. Each Boom Solution Valve Switch is equipped with an indicator light and will illuminate red when manually turned off.

Refer to the *Spray Systems Section* elsewhere in this manual for further information.

Fence Row Switches

The Fence Row Switches (located on the side console) are used in the selection of either the right or left fence row spray nozzle.



Fence Row Switches - Left/Right
(Located on the side console)
-Typical View

Refer to “Fence Row Application” provided in the *Spray Systems Section* elsewhere in this manual for further information.

Rear Nozzle Switch

The Rear Nozzle Switch (located on the side console) controls the two (2) rear nozzles (located behind the rear tires).



Rear Nozzle Switch
(Located on the side console)
-Typical View

Refer to the *Spray Systems Section* elsewhere in this manual for further information.

Rate Control Switches

The Rate Control Switches (located on the side console) control the rate in which solution is applied through the spray booms by either the rate controller (Enable) or operator-controlled spray rate (Manual).

NOTE: When both “MAN” and “ENABLE” Rate Control Switches are pressed, manual rate control is activated through the rate controller.



Rate Control Switches
(Located on the side console)
-Typical View

Refer to the *Spray Systems Section* elsewhere in this manual for further information.

Pump Speed/Rate Switches

The Pump Speed/Rate Switches (located on the side console) allow you to increase or decrease flow rate through the spray system.

NOTE: When the “MAN” Rate Control Switch is pressed, the Pump Speed/Rate Switches increase or decrease pump speed/application rate from the Hagie control system. When the “ENABLE” Rate Control Switch is pressed (with either “MAN” active or inactive), a third party rate controller increases or decreases pump speed/application rate.



Pump Speed/Rate Switches
(Located on the side console)
-Typical View

Refer to the *Spray Systems Section* elsewhere in this manual for further information.

Main Tank Valve Switch

The Main Tank Valve Switch (located on the side console) controls the solution tank valve. This switch must be in the ON (Open) position for spray application.



Main Tank Valve Switch
(Located on the side console)
-Typical View

Refer to the *Spray Systems Section* elsewhere in this manual for further information.

Solution Pump Switch

The Solution Pump Switch (located on the side console) is used to turn the Solution Pump ON/OFF.



Solution Pump Switch
(Located on the side console)
-Typical View

NOTE: Leaving the Solution Pump Switch in the ON position can cause the pump to run continuously, which may result in system damage.

Refer to the *Spray Systems Section* elsewhere in this manual for further information.

Agitation Valve Switch

The Agitation Valve Switch (located on the side console) controls the rate of flow through the Agitation System.



Agitation Valve Switch
(Located on the side console)
-Typical View

Refer to the *Spray Systems Section* elsewhere in this manual for further information.

Boom Extension Switches (Outer Fold)

WARNING

When operating or positioning the booms, observe the following safety precautions to avoid serious injury or death:

- Select a safe area before folding/unfolding booms.
- Clear area of personnel.
- Check for overhead obstructions.
- Do not fold/unfold booms near power lines. Contact with power lines can result in serious injury or death.



CAUTION

When operating or positioning the booms, observe the following safety precautions to avoid injury or equipment damage.

- Do not fold/unfold boom extensions when main boom is in cradle.
- Do not operate sprayer with one boom wing out of cradle and the other boom wing in cradle.
- Do not transport machine without booms folded and in cradle.

The Boom Extension Switches (located on the side console) are used to extend or retract the outer boom extensions.

NOTE: On 90-ft. Spray Booms, operate Boom Extension Switch 1 to unfold/fold the outer boom extensions simultaneously. On 120 and 132-ft. Spray Booms, operate both Boom

Extension Switches 1 (left) and 2 (right) to unfold/fold the outer boom extensions separately.

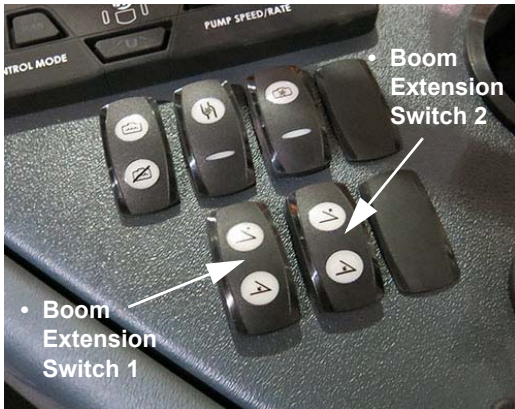

Boom Extension Switches - Left/Right
(Located on the side console)
-Typical View

Refer to the *Spray Systems Section* elsewhere in this manual for further information.

Ignition Switch

The Ignition Switch (located on the side console) has three positions - OFF, ON, and START. Before engaging the starter, turn the ignition key to the ON position and wait for the “wait to start” message to disappear on the Machine Display.

NOTE: The parking brake must be engaged before engaging the starter.



Ignition Switch
(Located on the side console)
-Typical View

- **To engage the starter**, turn the key to the START position and hold momentarily until the engine engages. If the engine does not engage after 15 seconds, turn the key to the OFF position.

NOTE: Constant cranking of the starter will cause damage to the battery and starting system.

Power Mirrors

-If Equipped

Your machine may be equipped with Power Mirrors for your operating convenience.

- Press the L/R Lever in the “L” position to adjust the LEFT mirror or in the “R” position to adjust the RIGHT mirror.
- Press the Adjust Switch to adjust the corresponding mirror to desired position.

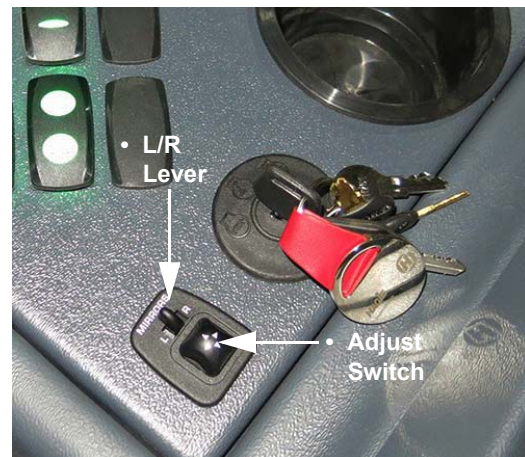

Power Mirror Switch
(Located on the side console)
-Typical View

Hydrostatic Drive Control Handle

The Hydrostatic Drive Control Handle controls various functions of the machine and attachments. It is used to control the direction of the machine and the speed in which it travels. It is also used to control the spray booms, end row management, master spray, and shift up/down speeds.



Front View

Side View

Hydrostatic Drive Control Handle
-Typical View

Shift Up/Down Switches

The Shift Up/Down Switches (located on the Hydrostatic Drive Control Handle) are used for speed range selection.

Refer to “Hydrostatic Drive” provided in the *Engine and Drive Systems Section* elsewhere in this manual for further information.

Refer to the *Engine and Drive Systems and Spray Systems Sections* elsewhere in this manual for further information.

Transom Switch - Up/Down

The Transom Switch (located on the Hydrostatic Drive Control Handle) is used to raise and lower the main lift.

Left and Right-Hand Boom Switches

The Left and Right-Hand Boom Switches (located on the Hydrostatic Drive Control Handle) are used to raise, lower, extend, and retract the spray booms.

Master Spray Switch

The Master Spray Switch (located on the Hydrostatic Drive Control Handle) activates the boom solution valves.

End Row Management Switch

The End Row Management Switch (located on the Hydrostatic Drive Control Handle) is a programmable switch that enables various functions (i.e. All-Wheel Steer, Auto Steer, Master Spray, and NORAC® Enable) when the switch is depressed.

NOTE: End Row Management functions are disabled in Road Mode.

Refer to “Machine Display” provided elsewhere in this section for programming information.



- (A) - Hydrostatic Drive Control Handle
- (B) - Right-Hand Boom IN
- (C) - Right-Hand Boom UP
- (D) - Right-Hand Boom OUT
- (E) - Right-Hand Boom DOWN
- (F) - Left-Hand Boom OUT
- (G) - Left-Hand Boom UP
- (H) - Left-Hand Boom IN
- (I) - Left-Hand Boom DOWN
- (J) - End Row Management Switch
- (K) - Transom Switch
- (L) - Master Spray Switch
- (M) - Shift Up Switch
- (N) - Shift Down Switch

Parking Brake Switch



Do not engage the parking brake while the machine is moving. Failure to comply may result in personal injury and machine damage.

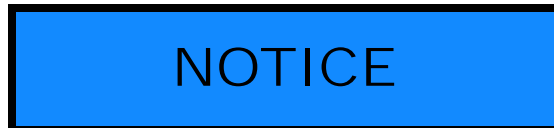

The parking brake is not intended for normal or emergency stopping.

The Parking Brake Switch (located near the Hydrostatic Drive Control Handle) is used to engage/disengage the parking brake, as well as extend/retract the ladder.

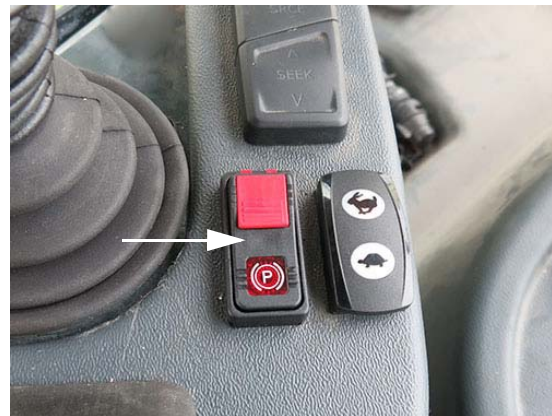

Parking Brake Switch
(Located near the Hydrostatic Drive Control Handle)
-Typical View

Refer to “Hydrostatic Drive” provided in the *Engine and Drive Systems Section* elsewhere in this manual for further information.

Throttle Switch

The Throttle Switch (located near the Hydrostatic Drive Control Handle) is used to control engine speed (RPM).

NOTE: The operator may select throttle setting by operating the Throttle Switch. However, engine speed is also controlled by movement of the Hydrostatic Drive Control Handle.



Throttle Switch
(Located near the Hydrostatic Drive Control Handle)
-Typical View

NOTE: Engine speed can range between 850 and 2200 RPM in both Road and Field Mode.

The Throttle Switch works with a timer to tell the engine how fast to run. The longer the operator holds the switch in either direction (press UP/“rabbit icon” to increase the speed, press DOWN/“turtle icon” to decrease the speed), the more the engine will speed up or slow down.

Remote Stereo Controls

Your machine is featured with Remote Stereo Controls (located near the Hydrostatic Drive Control Handle) for your convenience.

- **Volume Button** - Press button UP or DOWN to increase or decrease stereo sound.
- **Mute Button** - Press button to silence/ mute stereo sound. Press again to resume sound.
- **Source Button** - Press button to toggle through the source selections (Radio, CD, MP3, etc.)

NOTE: The selected source will be shown on the stereo display.

- **Seek Button** - Press button UP or DOWN to toggle through the radio channels or CD/MP3 selections.

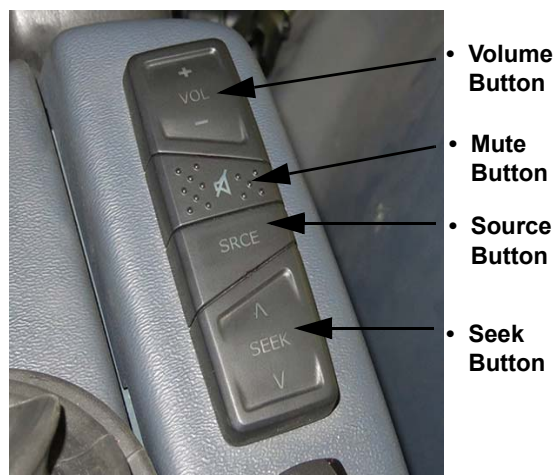

Remote Stereo Controls
(Located near the Hydrostatic Drive Control Handle)
-Typical View

Power Ports (12-Volt)

Four (4) Power Ports (three located on the inward side console panel and one located along the lower left-hand side of operator's seat) are provided for the connection of additional items (such as radios and computer equipment).

NOTE: The Power Ports are not intended for the permanent connection of additional systems to the sprayer.

Auxiliary Audio Input Connection (Aux 2)

The Aux 2 Audio Input Connection (located on the inward side console panel) allows you to connect a personal i-Pod or MP3 player.

NOTE: An Aux 1 Audio Input Connection is located on the stereo/radio.

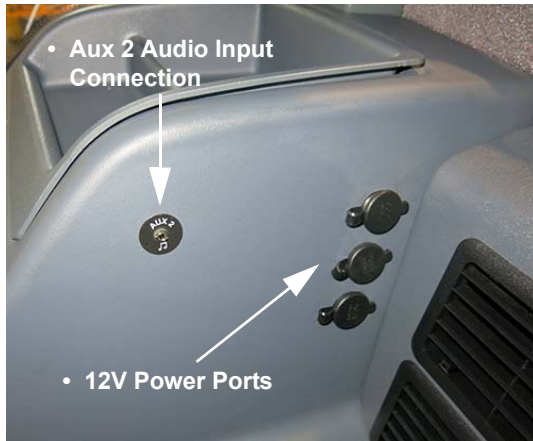

12V Power Ports and
Aux 2 Audio Input Connection
(Located on the inward side console panel)
-Typical View



-Typical View



-Typical View

Overhead Monitors and Controls

- (A) - Courtesy Light/Interior Work Light
- (B) - Stereo
- (C) - Climate Controls
- (D) - NORAC Monitor
- (E) - Spray System Console
- (F) - Machine Display
- (G) - Machine Gauges
- (H) - Section Indicator Display



-Typical View

(Your machine may vary, depending on model and available equipment)



-Typical View



-Typical View



-Typical View



-Typical View

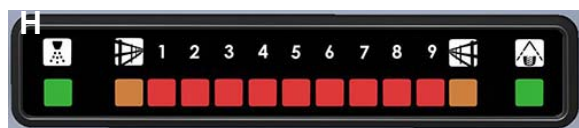

-Typical View

Courtesy Light/Interior Work Light

The Courtesy Light comes on automatically when the cab door is opened.

The Interior Work Light is activated by manually by pressing the Interior Work Light Switch (located on the light housing).

- Press switch UP to turn interior “white” light ON.
- Press switch DOWN to turn interior “red” light ON.
- Press switch in the mid-position to turn OFF.



Interior Work Light Switch
-Typical View

Stereo

The Stereo in your cab is featured with an AM/FM Tuner, Weatherband Broadcasting, CD Player, MP3 Player, USB/iPod Controls, and Bluetooth®.

- Select/Volume Knob
- Disp Button



- Back Button
- Preset Buttons (1-6)

Bluetooth Pairing (Registration)

1. Press desired Preset Button (1-6) to select a registration number assigned to the Bluetooth device to be registered.

NOTE: Up to eight (8) devices of memory registered with Preset Buttons.

- (1-5) - Selects a registration number (1st page: 1-5, 2nd page: 6-8).
 - (6) - Turns the registration pages (Registration No. 6 - press 6, then press 1; Registration No. 7 - press 6, then press 2; Registration No. 8 - Press 6, then press 3).
2. Press and hold the selected Preset Button for 2+ seconds until “Pairing” flashes on the display.
 3. Quickly release the Preset Button and press the Select/Volume Knob until “Waiting” appears on the display.
 4. Operate your Bluetooth device to input the PIN number for connection. Once pairing/registration is successful, the registered Bluetooth device can automatically communicate with this unit.

NOTE: Default PIN number = “0000”

- The text display of Bluetooth device name and telephone directory on this unit is only supported with English characters. Other languages and non-displayable characters/symbols will be converted into an asterisk (*).
- If registration is not successfully completed within one (1) minute, “TIME OUT” will appear and the screen for registration number selection resumes.
- If registration fails due to a mismatched PIN number, “PAIR ERR” will appear and

the screen for registration number selection resumes.

- Depending on the communication status, it may take 5 to 40 seconds for device connection.

NOTE: Press the Disp Button at any time to exit waiting status.

Music Mode Activation

- Press and hold the Back Button for 2+ seconds.

NOTE: If the Back Button is held down for 2+ seconds again, phone mode is activated.

Refer to the Stereo manufacturer's operation guide for complete operating instructions and programming information.

Climate Controls (Standard)



-Typical View

Fan Blower Speed (A)

- Rotate the Fan Blower Speed Dial "clockwise" to increase fan speed.
- Rotate the Fan Blower Speed Dial "counter-clockwise" to decrease fan speed.
- To shut the fan off, rotate the Fan Blower Speed Dial fully "counter-clockwise".

Temperature Setting (B)

- Rotate the Temperature Setting Dial "clockwise" to increase temperature.
- Rotate the Temperature Setting Dial "counter-clockwise" to decrease temperature.

Air Conditioner Switch (C)

- To activate the air conditioner, press the Air Conditioner Switch in the ON position

(toward switch indicator).

Adjust the fan speed and temperature accordingly.

Climate Controls (Optional)

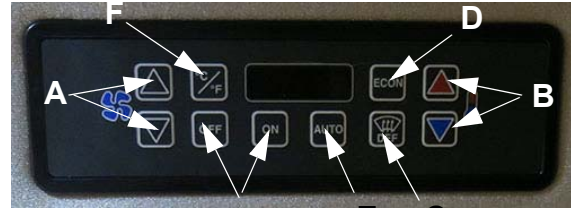

-Typical View

Fan Up/Down (A)

The Fan Up/Down Switches control the fan speed up or down in 11 increments and overrides the automatic fan speed control.

- Press desired switch UP to increase fan speed, or DOWN to decrease fan speed.
- The Digital Display indicates the fan speed setting as a percentage, or "HI" when maximum fan speed is obtained, or "LO" when minimum fan speed is obtained.

NOTE: The Digital Display will return to the normal display five seconds after either key is depressed.

The set point fan speed is maintained until it is changed, or until the Auto Mode Switch is depressed.

Temperature Up/Down (B)

The Temperature Up/Down Switches increments the cab set point temperature.

- Press desired switch UP to increase temperature, or DOWN to decrease temperature.

Defrost (C)

The Defrost Switch energizes the A/C system to allow for rapid cab dehumidification.

- Press the Defrost (DEF) Switch to turn ON.

NOTE: An indicator light will illuminate when defrost mode is active.

Economy Mode (D)

Economy Mode uses fresh air, fan speed, and water valve control to maintain the set point temperature. When active, A/C function is disabled.

- Press the Econ Switch to turn ON.
- Press the Econ Switch again to return the system back to normal operation.

NOTE: An indicator light will illuminate when Economy Mode is active.

Auto Mode (E)

Auto Mode allows the system to function in fully automatic temperature control mode, including automatic fan speed control. The system will adjust the fan speed to the lowest setting required to maintain cab set point temperature.

- Press the Auto Switch to turn ON and OFF.

NOTE: An indicator light will illuminate when auto mode is active.

Cab Temperature (F)

- Press the Cab Temp Switch to display set point on the Digital Display.

NOTE: Press the Cab Temp Switch and toggle between celsius (C) and fahrenheit (F) temperatures.

NOTE: Current cab temperature will be displayed for five seconds, then will return to the set point temperature display.

On/Off (G)

- The On/Off Switches power the cab heater/air conditioner systems ON or OFF.

NOTE: An LED numeric display is illuminated when the unit is turned on. The Digital Display will show the current set point temperature.

Cab Vents

Your cab is equipped with adjustable vents. Rotate to desired position, or individually turn on or off with the directional fins.



Cab Vent
-Typical View

Spray System Console

The spray system is controlled by the Spray System Console and the Solution Pump Control Valve. The system receives data and automatically makes adjustments based on the target rate of application set by the operator.



Spray System Console
-Typical View

(Your machine may vary, depending on model and available equipment)

Refer to the manufacturer's operation manual for complete operating instructions and programming information.

NORAC Monitor

-If Equipped

The NORAC Monitor controls the automatic boom leveling system.



NORAC Monitor
-Typical View

Refer to the manufacturer’s operation manual for complete operating instructions.

Machine Display

The Machine Display in your sprayer is the central control center of the machine. It controls many of the machine’s electronically-driven functions (e.g. machine drive, AWS, attachment operation, tread adjustment, spray systems, lights, diagnostics, etc.)



Machine Display
-Typical View

Refer to “Machine Display” provided elsewhere in this section for a complete list of features and operating instructions.

Machine Gauges

Machine Gauges are located on the A-post in your cab and are conveniently placed for viewing machine diagnostics.



- Tachometer (RPM Gauge)
- Fuel Gauge
- Engine Coolant Gauge
- Aftertreatment Gauge

Machine Gauges
(Located on cab A-post)
-Typical View

Section Indicator Display

The Section Indicator Display allows you to view system status for the following:

- (1) - Master Spray Indicator (illuminates when ON).
- (2) - Fence Row Indicators (illuminate when ON).
- (9) - Spray Section Indicators (illuminate when OFF).
- (1) - Rear Wheel Nozzle Indicator (illuminates when ON).

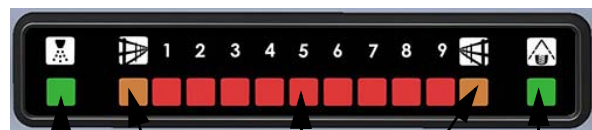

- Master Spray
- Left Fence Row
- Spray Section
- Right Fence Row
- Rear Wheel Nozzle

Section Indicator Display
-Typical View

Refer to the *Spray Systems Section* elsewhere in this manual for further information.

Lighting

NOTE: See Front Console components discussed earlier in this section for information on Hazard/Warning Lights and Highway Running Lights.

Field Lights

The Field Lights (located on the front of cab) are for use when operating in the field after dark and are turned on/off through the Machine Display.

NOTE: Turn Field Lights OFF before entering a public roadway.

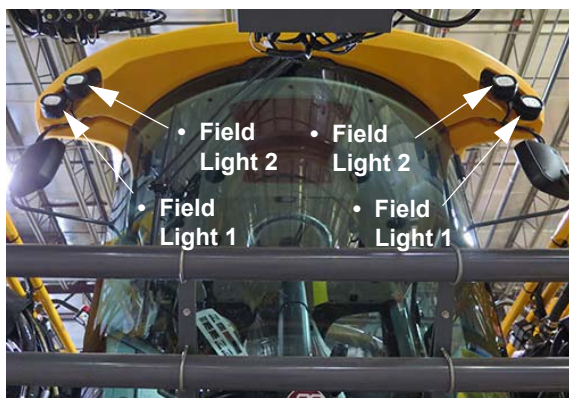

Field Lights (4)
(Located on the front of cab)
-Typical View

NOTE: The ignition key must be in the ON position to operate the Field Lights.

Refer to “Machine Display” provided elsewhere in this section for operating instructions.

Work Lights

The Work Lights (located on each boom cradle) are for use when operating in the field after dark and are turned on/off through the Machine Display.

NOTE: Turn the Work Lights OFF before entering a public roadway.



Work Lights (2)
(Located on each boom cradle)
-Typical View

NOTE: The ignition key must be in the ON position to operate the Work Lights.

Refer to “Machine Display” provided elsewhere in this section for operating instructions.

Attachment Lights

The Attachment Lights (located on the front of transom) are for use when operating in the field after dark and are turned on/off through the Machine Display.

NOTE: Turn the Attachment Lights OFF before entering a public roadway.

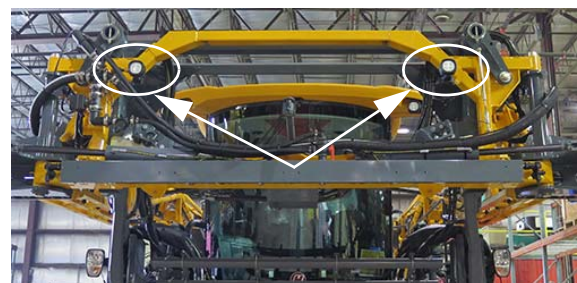

Attachment Lights (2)
(Located on the front of transom)
-Typical View

NOTE: The ignition key must be in the ON position to operate the Attachment Lights.

Refer to “Machine Display” provided elsewhere in this section for operating instructions.

Night Spray Lights

-If Equipped

The Night Spray Lights (located on each side of the main boom fold section) are for use when operating in the field after dark and are turned on/off by the Attachment Lights Button (located on the Machine Display Auxiliary Controls Page). The Night Spray Lights are adjustable and may be positioned to light up the spray pattern.

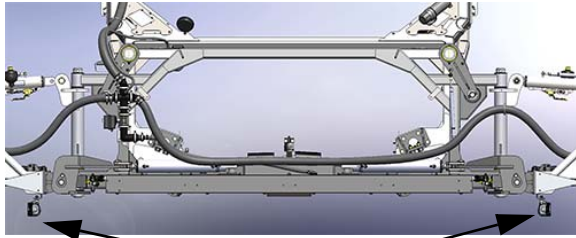

Night Spray Lights (2)
(Located on each side of
the main boom fold section)
-Typical View

NOTE: The Battery Disconnect Switch (located inside the engine compartment on the rear right-hand side of machine - open hood to access) must be in the ON position to activate the Night Spray Lights.

NOTE: Turn the Night Spray Lights OFF before entering a public roadway.

Refer to “Machine Display” provided elsewhere in this section for operating instructions.

Cab Filtration

RESPA® Cab Filter

The cab is featured with a dust and aerosol filtration system to provide continuous positive pressure in the cab by reducing exposure to harmful particulates. A 3” (7.6 cm) air intake pipe is used to reduce excessive fresh air intake in the cab for improved cooling.

NOTE: The filtration system will activate automatically approximately 10 seconds after machine start-up.



Cab Filtration System
(Located on the right-hand
side of the exterior cab)
-Typical View

An indicator light (located on the Machine Display Home Page) will appear if insufficient cab air pressure should occur.

NOTE: The Insufficient Cab Air Pressure Indicator will appear each time the machine is started due to the initial activation delay. The indicator will disappear once the cab becomes pressurized.

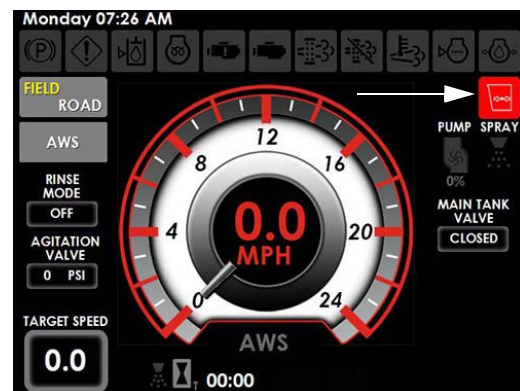

Insufficient Cab Air Pressure Indicator
(Located on the Machine Display
Home Page - Road or Field Mode)

Refer to “Service - Filters” provided in the *Maintenance and Storage Section* elsewhere in this manual for filter replacement information.

Charcoal/Recirculation Filters

Your cab is featured with a Charcoal Filter (located behind the exterior service panel on the right-hand side of cab), which eliminates hazardous chemicals from the operator's station. In addition, a Recirculation Filter (accessible after the Charcoal Filter has been removed) is provided to cleanse air inside the cab, keeping the operator's environment fresh.



Charcoal Filter
(Located behind the exterior service panel on the right-hand side of cab)
-Typical View

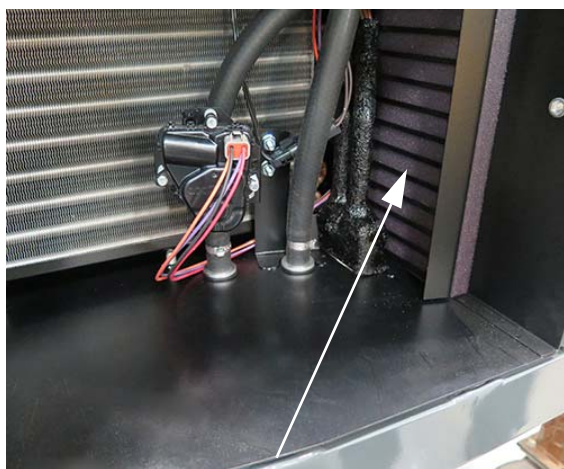

Recirculation Filter
(Located along the right-hand side of service compartment)
-Typical View

* View shown with charcoal filter removed

Refer to “Service - Filters” provided in the *Maintenance and Storage Section* elsewhere in this manual for further information on filter maintenance.

Additional Features

Portable Electric Cooler

-If Equipped

Your machine may be equipped with a Portable Electric Cooler (located beneath the Instructor Seat) for your personal convenience. A 12-volt connection outlet is provided along side of the operator's seat.

MACHINE DISPLAY

(Typical View - Your machine may vary in appearance, depending on available equipment)

The Machine Display in your sprayer is the central control center of the machine. It controls many of the machine's electronically-driven functions, such as:

- Machine Drive
- All-Wheel Steer (if equipped)
- Attachment Operation
- Hydraulic Tread Adjustment (if equipped)
- Spray System
- Reversible Fan
- Backup Video Camera
- Exterior Lights
- Diagnostics



Machine Display
-Typical View

Machine Display Page Settings

The Machine Display is featured with six display pages:

- Home Page (Road Mode)
- Home Page (Field Mode)
- Auxiliary Controls Page
- Video Camera Page
- Machine Diagnostics Page
- Settings Page

Press the corresponding Page Display Button (located on the right-hand side of the Machine Display) to navigate through the display pages.



Page Display Buttons
(Located on the right-hand
side of the Machine Display)

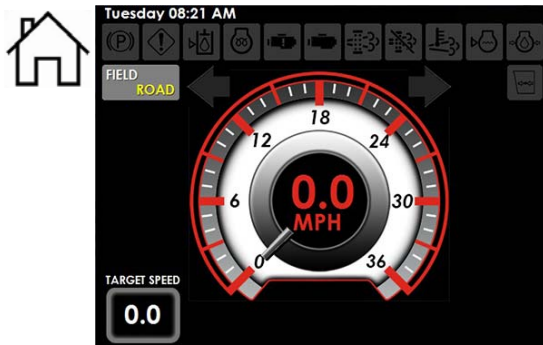

Home Page (Road Mode)

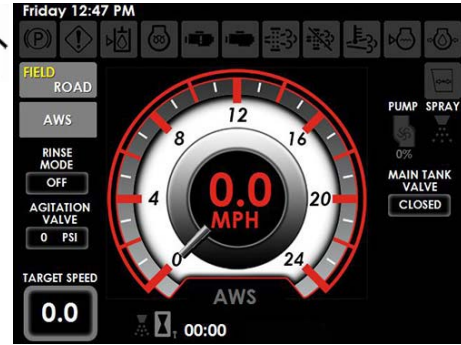

Home Page (Field Mode)

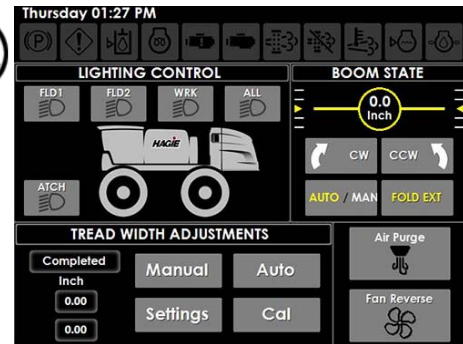

Auxiliary Controls Page

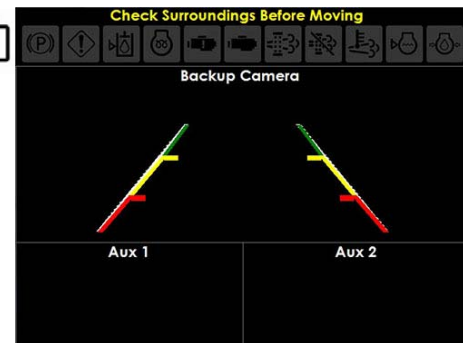

Video Camera Page

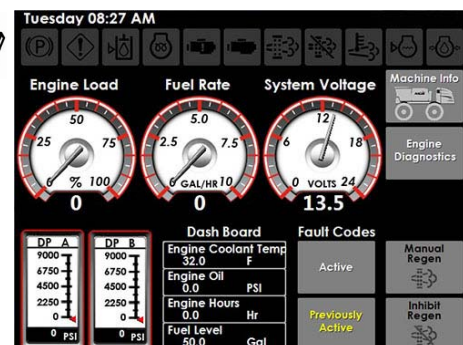

Machine Diagnostics Page

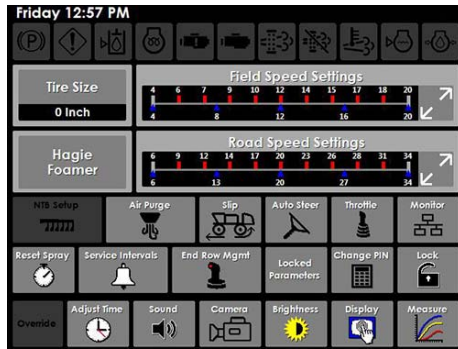
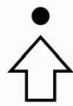

Settings Page

Speed Settings and Machine Adjustments

Throughout this manual, various adjustments are made through the Field/Road Speed Settings and Machine Adjustments (located on the Settings Page).

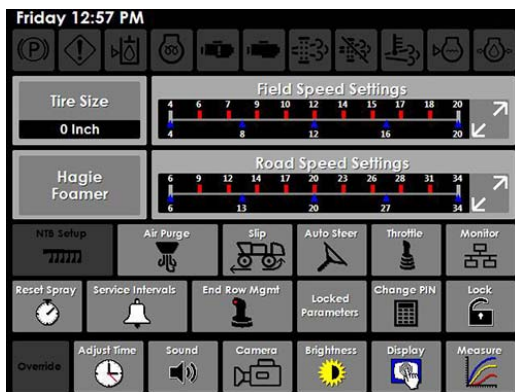

Speed Settings and Machine Adjustments
(Located on the Settings Page)

NOTE: The machine must be stationary before allowing certain Speed Setting and Machine Adjustments.

Field/Road Speed Settings

- First Range Top Speed
- Last Range Top Speed
- Number of Ranges
- AWS Shutoff Speed (Field Speed Settings only)

Machine Adjustments

Auto Steer

- SASA T-Delay On
- SASA T-Delay Off
- A-Steer Sensitivity

Slip (Traction Control)

- Slip Percent
- Slip Destroke

CAN Monitor

- Enable CAN1
- Enable CAN2
- Enable CAN3

Display

- Units (Standard/Metric)
- Animations
- Gauge Color
- Language

Brightness

- Day Time Brightness
- Night Time Brightness
- Transition Settings

Camera

- Backup Camera
- Aux Camera 1
- Aux Camera 2
- Edit Overlay
- Settings
- Flip Vertical
- Flip Horizontal

Throttle

- Throttle Control Slope
- Throttle Up Ramp
- Throttle Max
- Decel Pedal Min Speed

End Row Management

- All Wheel Steer
- Auto Steer
- Master Spray
- NORAC® Enable

Foamer

- Total Flow
- Concentrate

Tire Size

- Rolling Circumference

Air Purge

- Manual Mode
- Automatic Mode

Service Intervals

- 50-Hour Interval
- 100-Hour Interval
- 500-Hour Interval
- Hydraulic Filter
- Hydraulic Oil
- Engine Oil

NTB/60' HsTB Setup

-If Equipped

- NTB Override Timer
- Float With Transom Down
- One Tap Transom Up

NOTE: Refer to your Nitrogen Tool Bar operator's manual for further information.

Machine Setting Security

To Lock Machine Settings

- Press the Locked Parameters Button (located on the Settings Page).

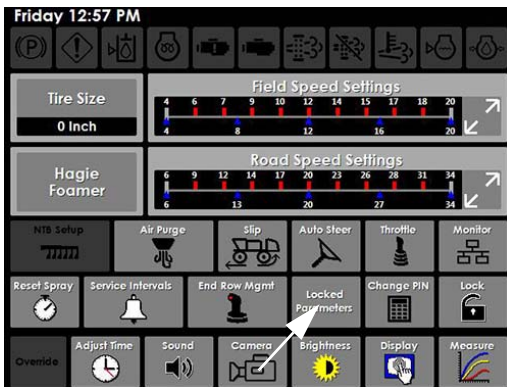

Locked Parameters Button
(Located on the Settings Page)

- On the “Change Locked Parameters” screen, press the Up/Down Arrow Buttons until desired setting is displayed.

NOTE: Single arrow buttons toggle up/down one page. Double arrow buttons toggle to either the first or last page.



Change Locked Parameters Screen

- Press the “lock icon” next to desired setting to the LOCKED position.
- Press OK.
- Press the Lock Button (located on the Settings Page).
- Press OK to confirm locked settings.

NOTE: When the Lock Button is pressed, the Locked Parameters and Change Pin Buttons will disappear. These buttons will re-appear when the Lock Button is pressed and the correct pin number is entered.

NOTE: Default Pin Number is “50525”.

To Unlock Machine Settings

- Press the “red illuminated” Lock Button (located on the Settings Page).

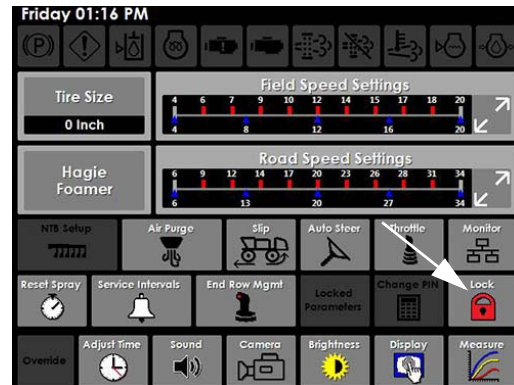

Lock Button
(Located on the Settings Page)

- On the “Enter Lock Password” screen, enter pin number.
- Press UNLOCK.

To Change Pin Number

- Press the Change Pin Button (located on the Settings Page).

NOTE: Press the Lock Button and enter current pin number to enable the “Change Pin Button” to re-appear on the display.

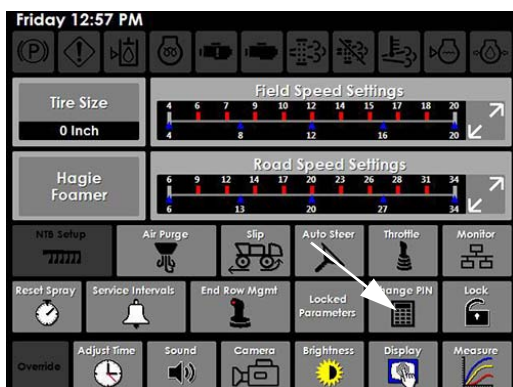













Change Pin Button
(Located on the Settings Page)

- On the “Set New Password” screen, enter newly-selected 5-digit pin.
- Press OK.

NOTE: A “Password Changed” confirmation will appear when complete.

Machine Display Indicators

To alert the operator of certain operations or when a machine system requires attention, various Machine Display Indicators are located on the top of each display page and illuminate to inform you of a specific situation.

-  • Parking Brake ON
-  • Machine Warning
-  • Check Engine
-  • Stop Engine
-  • Exhaust System Cleaning
-  • Engine Cleaning Stop
-  • High Exhaust Temperature (HEST)
-  • Low Diesel Exhaust Fluid (DEF) (Final Tier 4 Engines)
-  • Low Engine Oil Pressure
-  • Low Engine Coolant Level
-  • Low Hydraulic Oil Level
-  • Insufficient Cab Air Pressure

Warning Light Indicator

When a system error requires attention, a Machine Warning Light Indicator (located on the top left-hand side of each display page) will illuminate. This indicator will be accompanied by a warning buzzer and a warning message telling you what the error is and what should be done to correct it.

NOTE: The error message may be cleared by pressing OK or ACKNOWLEDGE and the warning buzzer may be silenced by pressing the Sound Button (located on the Settings Page) to the OFF (red illuminated “disabled”) position. However, the Warning Light Indicator will remain illuminated until the issue has been corrected.

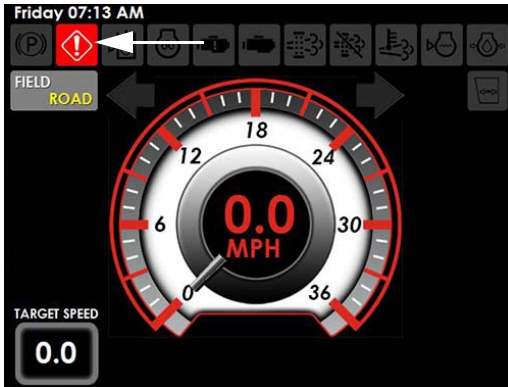

Warning Light Indicator
(Located on the top left-hand side of each display page)

Warning Buzzer

The Warning Buzzer alerts the operator when a system fault is detected and requires immediate attention. To silence the buzzer, press the Sound Button (located on the Settings Page) to the OFF (red illuminated “disabled”) position.

NOTE: The Sound Button will reset to the ON (enabled) position each time the ignition key is cycled.

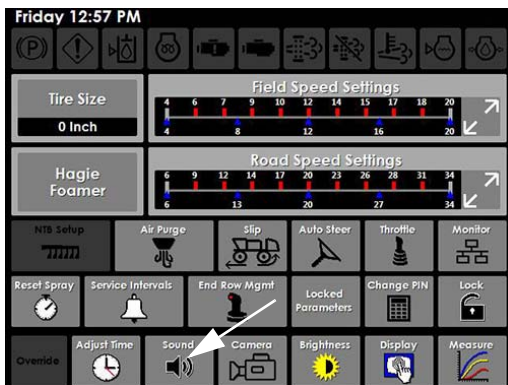

Sound Button
(Located on the Settings Page)

Lighting Adjustment

(Day Time/Night Time)

To Adjust the Display, Section Keypad, Side Console Switches, and Gauge Post Lighting

- Press the Brightness Button (located on the Settings Page).

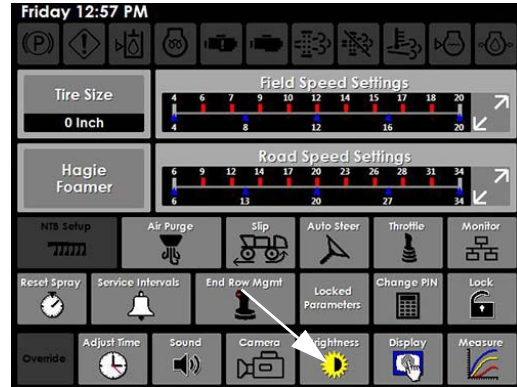

Brightness Button
(Located on the Settings Page)

- On the “Brightness” screen, press desired “Day Time” or “Night Time” Button.

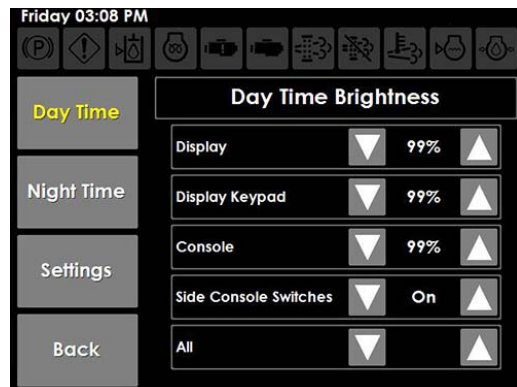

Brightness Screen

- Adjust corresponding day time and/or night time Display, Section Keypad, Side Console Switches, Gauge Post, or All brightness levels UP or DOWN to desired setting.
- Press BACK when finished.

To Set Automatic Night Time/Day Time Transition Brightness

NOTE: Brightness levels must be manually set (as previously described) before setting automatic transition brightness.

- On the “Brightness” screen, press the Settings Button.
- On the “Transition Settings” screen, press EDIT (next to Enable Time Transition).



Transition Settings Screen

- Select YES.
- Press OK.
- Press EDIT (next to Night Time Hour Start).
- Enter desired value (time of day that night time brightness will activate).
- Press OK.
- Press EDIT (next to Night Time Minute Start).
- Enter desired value (time of day that night time brightness will activate).
- Press OK.

NOTE: Repeat in the same manner for adjusting Day Time Hour and Minute Start).

- Press OK.
- Press BACK when finished.

Display Units/Animations/Gauge Color/Language

Units

To change units of measure:

- Press the Display Button (located on the Settings Page).

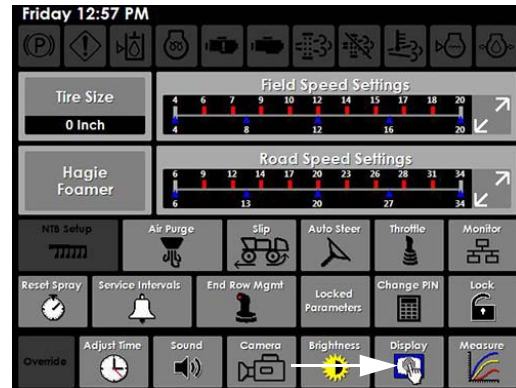

Display Button
(Located on the Settings Page)

- On the “Display Settings” screen, press EDIT (next to Units) and select one of the following options:
 - Standard
 - Metric (Bar)
 - Metric (KPA)



Display Settings Screen

- Press OK.

Animations

- Press the Display Button (located on the Settings Page).
- On the “Display Settings” screen, press EDIT (next to Animations) and select “Yes” to enable animations, or “No” to disable animations.
- Press OK.

Gauge Color

- Press the Display Button (located on the Settings Page).
- On the “Display Settings” screen, press EDIT (next to Gauge Color) and select desired color.

- Press OK.

Language

- Press the Display Button (located on the Settings Page).
- On the “Display Settings” screen, press EDIT (next to Language) and select preferred language.



Language Selection Screen

- Press OK.

NOTE: Press and hold the Settings Page Display Button (located on the right-hand side of the Machine Display) for approximately 10 seconds to navigate directly to the “Language Selection” screen.

Date and Time

The date and time is located on the upper left-hand corner of each display page and is set to central-standard time.

To Change Date or Time

- Press the Adjust Time Button (located on the Settings Page).

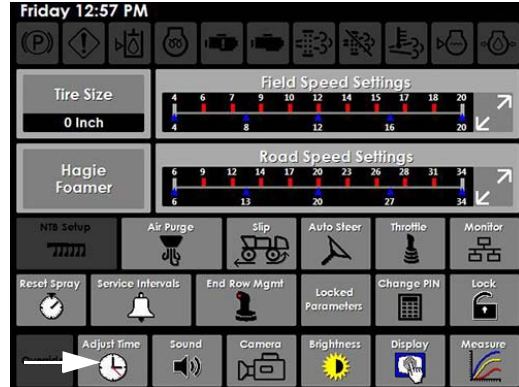

Adjust Time Button
(Located on the Settings Page)

- On the “Adjust Date and Time” screen, enter new date and time by pressing the corresponding Up/Down Buttons.



Adjust Date and Time Screen

- Press OK.

Machine Information

Machine information, such as total engine/machine hours, software version, attachment information, and machine serial number are located on the Machine Information screen.

- Press the Machine Information Button (located on the Machine Diagnostics Page) to view information.

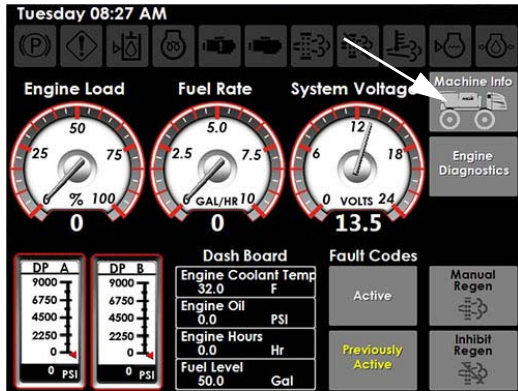

Machine Information Button
(Located on the
Machine Diagnostics Page)

Software Information

The Machine Display Software Information provides information on current software used and the date that it was released for the following:

- Primary Hydraulic Controller
- Secondary Hydraulic Controller
- Primary Display Controller

Attachment Information

The machine recognizes which attachment (e.g. 90-ft. Boom, 120-ft. Boom, Detasseler Tool Bar, or Nitrogen Tool Bar, if equipped) is connected to the machine and is displayed on the Machine Information screen.

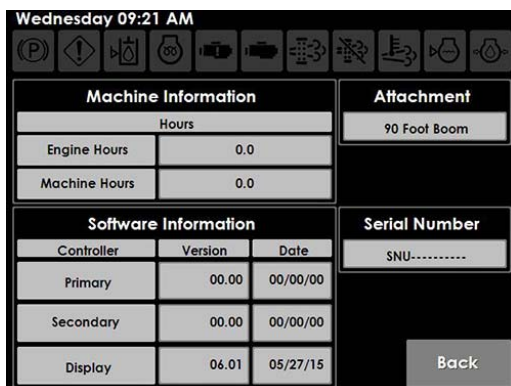

Machine Information Screen

Exterior Lights

(Field Lights, Work Lights, and Attachment Lights)

The exterior machine lights are activated through the Auxiliary Controls Page.

NOTE: The light buttons will illuminate when in the ON position.

Field Light Buttons

The Field Lights are located on front of the cab.

- Press the Field Lights Button(s) (FLD1 and/or FLD2) to turn Field Lights ON. Press button(s) again to turn Field Lights OFF.

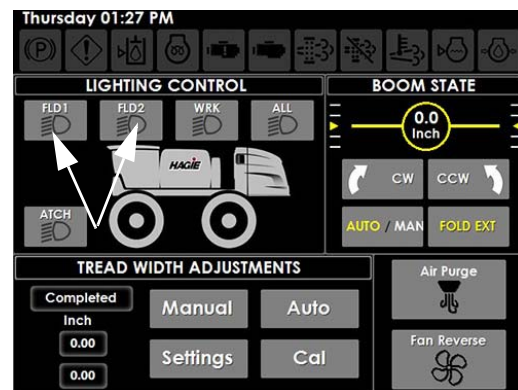

Field Light Buttons
(Located on the Auxiliary Controls Page)

NOTE: Turn Field Lights OFF before entering a public roadway.

NOTE: The ignition key must be in the ON position to operate the Field Lights.

Work Lights Button

The Work Lights are located on each of the boom cradles.

- Press the Work Lights Button (WRK) to turn Work Lights ON. Press button again to turn Work Lights OFF.

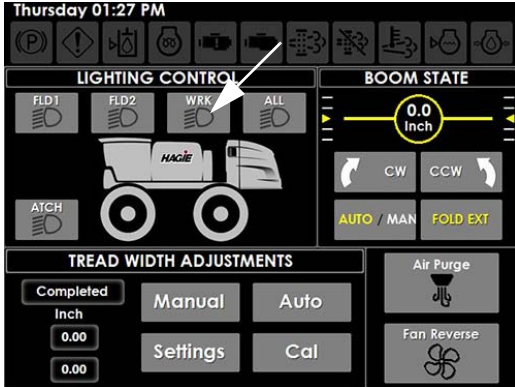

Work Lights Button

(Located on the Auxiliary Controls Page)

NOTE: Turn Work Lights OFF before entering a public roadway.

NOTE: The ignition key must be in the ON position to operate the Work Lights.

Attachment Lights Button

The Attachment Lights are located on the front of the transom.

- Press the Attachment Lights Button (ATCH) to turn Attachment Lights ON. Press button again to turn Attachment Lights OFF.

NOTE: The Attachment Lights Button also activates the Night Spray Lights (if equipped).

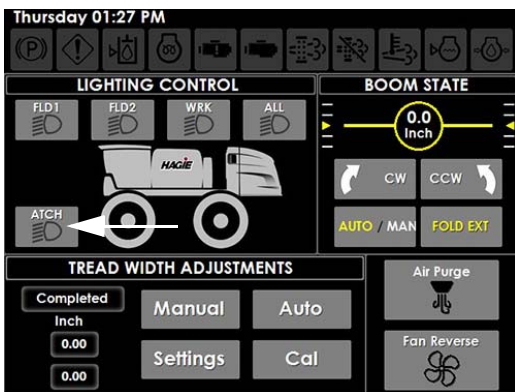

Attachment Lights Button

(Located on the Auxiliary Controls Page)

NOTE: Turn Attachment Lights OFF before entering a public roadway.

NOTE: The ignition key must be in the ON position to operate the Attachment Lights.

All Lights Button

- Press the All Lights Button (ALL) to turn on all lights (Field, Work, Attachment - *if equipped*, and Night Spray - *if equipped*) ON. Press button again to turn all lights OFF.

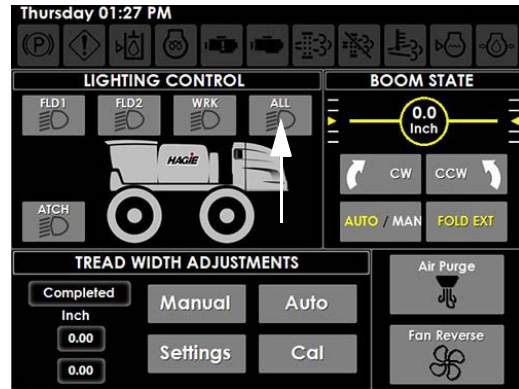

All Lights Button

(Located on the Auxiliary Controls Page)

NOTE: The ignition key must be in the ON position to operate the Exterior Lights.

Video Camera

Your machine is equipped with a Video Camera for your convenience when operating the machine in reverse and is located on the rear of the sprayer.

- On the Video Camera Page, press desired camera display to view in half-screen mode. Press again to view in full-screen mode.

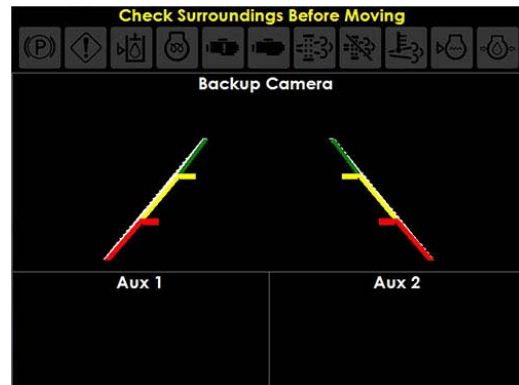

Video Camera Page

NOTE: Two additional video camera input connections (located beneath cab - remove front panel to access) are

provided for the installation of add-on video camera(s).

Refer to “Video Camera Input Connections” provided in the Electrical Systems Section elsewhere in this manual for further information.

Video Camera Settings

To Adjust Video Camera Settings

- Press the Camera Button (located on the Settings Page).

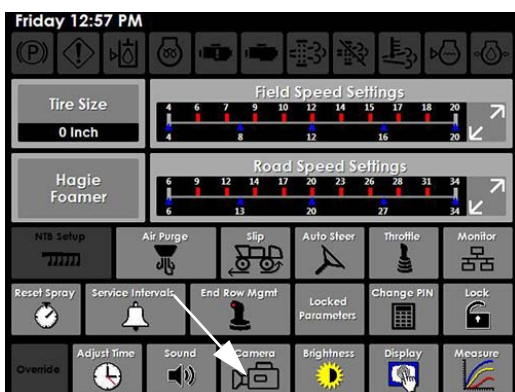

Camera Button
(Located on the Settings Page)

- On the “Camera Settings” screen, select either BACKUP CAMERA, AUX CAMERA 1, or AUX CAMERA 2.

NOTE: Press the “Flip Vertical” or “Flip Horizontal” Button to rotate object to desired position.

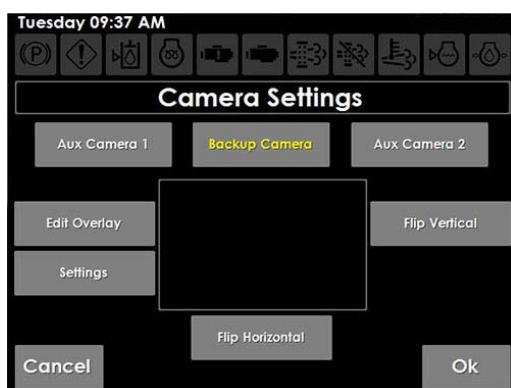

Camera Settings Screen

Edit Overlay

- Press the Edit Overlay Button (located on the “Camera Settings” screen).

- Select desired display adjustment (Top, Middle 1, Middle 2, or Bottom).

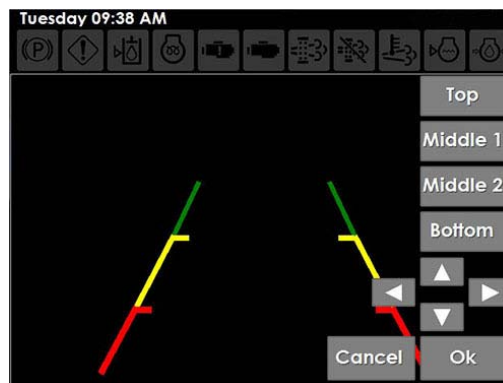

Edit Overlay Screen

- Drag display angle to desired position.
NOTE: Press and hold the Arrow Buttons to “fine-tune” display angle.
- Press OK.

Settings

- Press the Settings Button (located on the “Camera Settings” screen).
- On the “Camera Adjustable Settings” screen, press EDIT next to desired setting (Backup Camera in Reverse, Backup Camera Overlay, Backup Camera Projection, or Enable Camera in Road Mode).

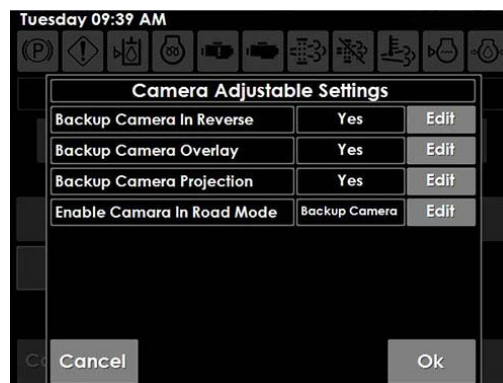

Camera Adjustable Settings Screen

- Press YES to activate, or NO to deactivate.

Service Intervals

To Change Service Interval Settings

- Press the Service Intervals Button (located on the Settings Page).

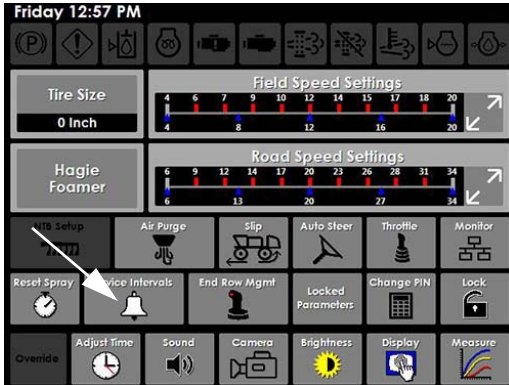

Service Intervals Button
(Located on the Settings Page)

- On the “Select Service Interval” screen, select desired service interval.

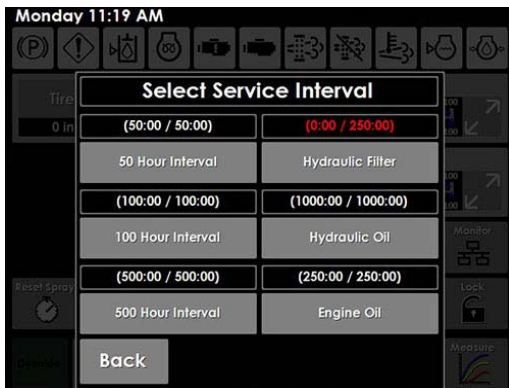

Select Service Interval Screen

- Press EDIT (next to the service interval you wish to change).
- Enter desired value.
- Press OK.
- Press RESET INTERVAL.
- Press BACK to return to the “Select Service Interval” screen. Press BACK again to return to the Settings Page.

Drive State

The Drive State of the machine is displayed on the Home Page - Road and Field Mode.

- Press the Field/Road Button (located on the Home Page) to toggle between the two Drive States. The selected Drive State will illuminate.



Field/Road Button
(Located on the Home Page - Road and Field Mode)

NOTE: The Drive State of the machine cannot be changed unless the Hydrostatic Drive Control Handle is in the NEUTRAL position (and machine speed is less than 0.5 mph/ 0.8 km/h).

The machine is featured with three (3) Drive States: ROAD, FIELD, and FAULT. The Drive State helps the machine determine what kind of work it is meant to do - field work or transport work.

Road Mode

In Road Mode, the machine is limited on what functions can be operated. Road Mode is used for transporting of the machine and therefore, will allow the machine to reach maximum speed.

NOTE: Engine speed in Road Mode can range from 850 to 2200 RPM.

Field Mode

In Field Mode, the machine is allowed function of attachments, such as Spray Booms, Detasseler Combo Tool Bar, and Nitrogen Toolbar (if equipped). All-Wheel Steer (if equipped) is also only allowed in Field Mode.

NOTE: Machine speed is limited and is unable to reach maximum speed while in Field Mode.

Drive Fault

The third drive state, “Drive Fault” may appear as a warning message on the display page if there is a system malfunction that affects the machine’s ability to function properly. This message will tell you why the error occurred and what, if anything, should be done to correct the issue. As a result, machine performance will be limited.

NOTE: When a Drive Fault is present, the Field/Road Button (located on the Home Page) will be replaced by “FAULT”. Settings will be in Field Mode.

Speedometer

The speed in which the machine travels is displayed on the Home Page - Road and Field Mode. The unit of measure can be viewed as miles per hour (mph) or kilometers per hour (km/h).

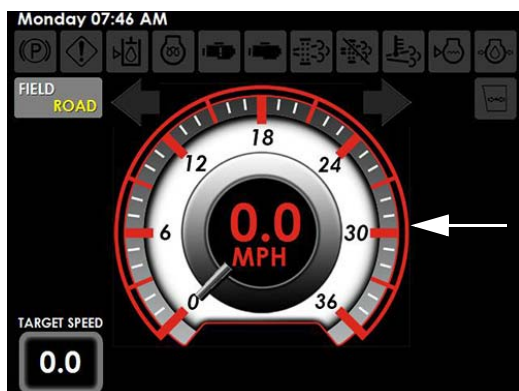

Speedometer
(Located on the Home Page
- Road or Field Mode)

NOTE: See “Display Units/Animations/ Gauge Color/Language” for information on changing the unit of measure.

Target Speed

NOTE: Machine speed is limited to 20 mph (32 km/h) when the solution tank level exceeds the transport limit. Refer to “Specifications” provided in

the Introduction Section elsewhere in this manual for transport limit on your machine.

The Target Speed (displayed on the Home Page - Road and Field Mode) is the speed in which the machine travels when the Hydrostatic Drive Control Handle is in the fully FORWARD position and the Decel Pedal is NOT pressed.

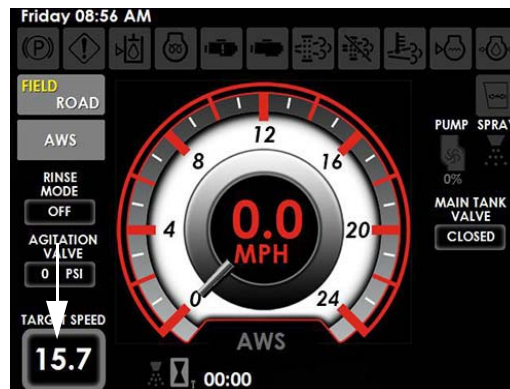

Target Speed
(Located on the Home
Page - Road and Field Mode)

To Change Target Speed

- Press the Adjust Button (located on the Settings Page) for desired field or road speed setting.

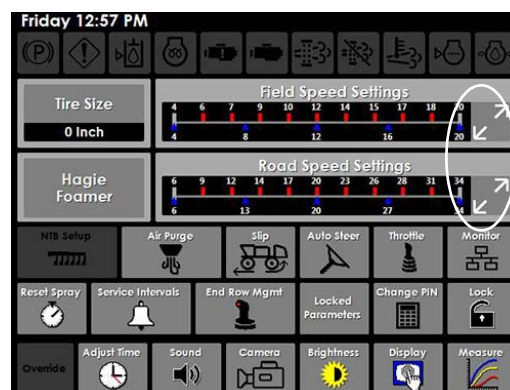

Adjust Buttons - Field/Road Speed Settings
(Located on the Settings Page)

- On the “Speed Settings” screen, evenly space target speeds as desired using the Up/Down Buttons for each setting (First Range Top Speed, Last Range Top Speed, and Number of Ranges).

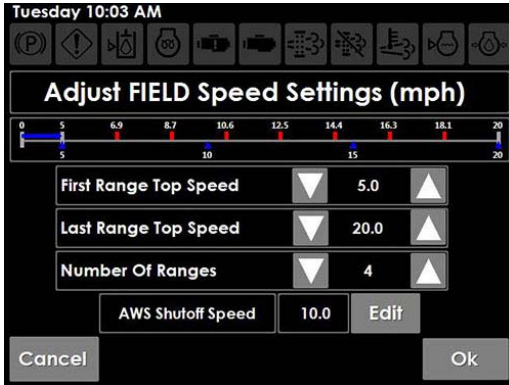

Speed Settings Screen
* Field Speed Settings Shown

Example:

If the “Number of Ranges Field” is set to 4, First Range Top Speed=5, and Last Range Top Speed=20, range selection would look like the following:

| Range | 1 | 2 | 3 | 4 |
|--------------|---|----|----|----|
| Target Speed | 5 | 10 | 15 | 20 |

- Press OK.
The machine will automatically adjust the new Target Speed according to the newly entered values.

Throttle

Throttle Control Slope

Determines how fast engine speed increases when the Throttle Switch (located near the Hydrostatic Drive Control Handle) is pressed in the UP (“rabbit icon”) position.

NOTE: Values are set as a percentage per second.

NOTE: If Throttle Control Slope is set at 25 percent/per second and Throttle Max is set at 100 percent, Throttle Up Ramp should be at least four (4) seconds to achieve 100 percent throttle when operating the Throttle Switch.

Throttle Up Ramp

Amount of time engine speed will increase or decrease when the Throttle Switch (located near the Hydrostatic Drive Control Handle) is pressed UP or DOWN.

Throttle Max

Maximum percentage that engine speed will achieve (e.g. If Throttle Max is set at 100 percent, throttle control will set engine speed between 850 and 2200 RPM. If Throttle Max is set at 0 percent, maximum engine speed will be 850 RPM).

NOTE: Pressing the Throttle Switch (located near the Hydrostatic Drive Control Handle) in the UP (“rabbit icon”) position will not increase engine speed when Throttle Max is set at 0 percent.

To Change Throttle Setting Values

- Press the Throttle Button (located on the Settings Page).

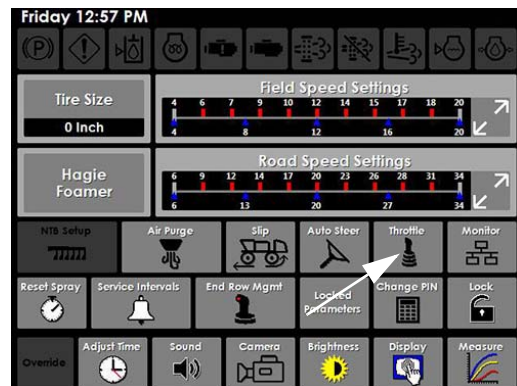

Throttle Button
(Located on the Settings Page)

- On the “Throttle Settings” screen, press EDIT (next to the desired Throttle setting).

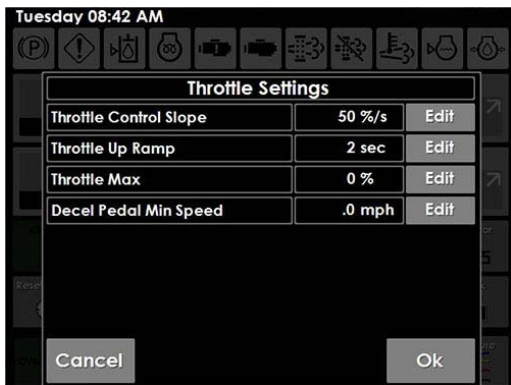

Throttle Settings Screen

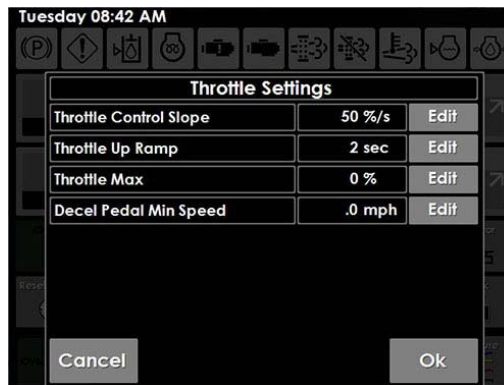

Throttle Settings Screen

- Enter desired value, then press ACCEPT.
- Press OK.

Refer to “Hydrostatic Drive” provided in the *Engine and Drive Systems Section* elsewhere in this manual for further information.

Decel Pedal Minimum Speed

The Decel Pedal (located to the lower right-hand side of steering column) is used for speed deceleration (e.g. when nearing an end row).

NOTE: The Decel Pedal is NOT a brake! It is designated for speed reduction only.

To Adjust Decel Pedal Minimum Speed

- Press the Throttle Button (located on the Settings Page).

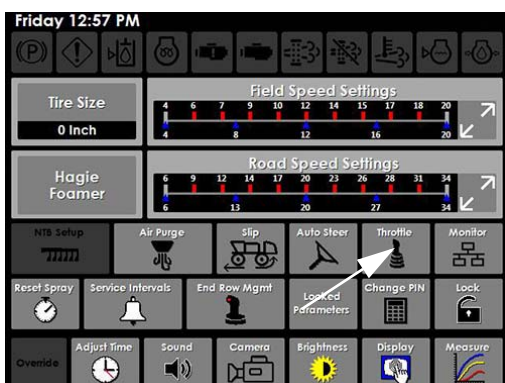

Throttle Button
(Located on the Settings Page)

- On the “Throttle Settings” screen, press EDIT (next to Decel Pedal Min Speed).

- Enter desired value, then press ACCEPT.
- Press OK.

All-Wheel Steer (AWS) ^

-If Equipped

The AWS Button is located on the Home Page - Field Mode. Enable AWS by pressing the button in the ON (illuminated) position. An AWS indicator (located below the speedometer) will illuminate when AWS is activated (requiring all conditions to be met).

• AWS Button

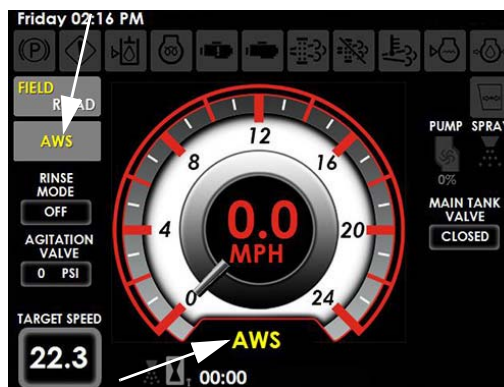

• AWS Indicator

All conditions must be met before AWS will activate. First, the machine must be in Field Mode, and second, machine speed must be less than AWS Shutoff Speed (mph-km/h). If these conditions are not met, the AWS Button will remain ON, but the AWS indicator will turn OFF, and the machine will be operating in conventional steering mode.

When conditions are met again, AWS will automatically activate and the AWS indicator will illuminate.

NOTE: The machine will automatically determine if the proper conditions have been met and change the status of the drive functions.

Shutoff Speed for AWS

NOTE: AWS Shutoff speed default is set to 10 mph (16 km/h).

- Press the Field Speed Settings Adjust Button (located on the Settings Page).

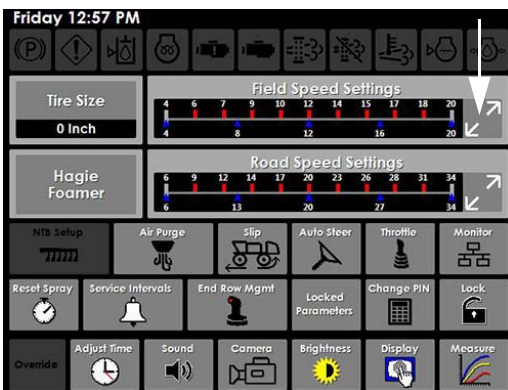

Field Speed Settings Adjust Button
(Located on the Settings Page)

- On the “Adjust Field Speed Settings” screen, press EDIT (next to AWS Shutoff Speed).

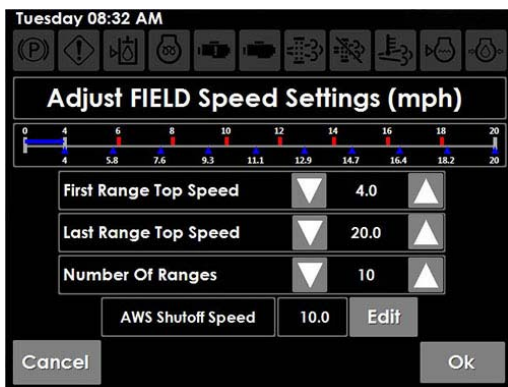

Adjust Field Speed Settings Screen

- Enter desired value.
- Press ACCEPT.
- Press OK.

Refer to “All-Wheel Steer” provided in the *Engine and Drive Systems Section* elsewhere in this manual for complete operating instructions and safety precautions.

Auto Steer

Steering Angle Sensor Absolute (SASA)

The absolute value of the steering wheel angle.

SASA T-Delay ON

Amount of time (in milliseconds) that the steering wheel must NOT move before Auto Steer can engage.

NOTE: The operator must engage Auto Steer through the foot pedal/end row management switch/auto steer controller display to engage Auto Steer after the steering wheel is not moving.

SASA T-Delay OFF

Amount of time (in milliseconds) that the steering must move before Auto Steer will disengage.

NOTE: Auto Steer will disengage if active/on.

NOTE: Default is set to 70 ms (less than 0.1 seconds) for both delay On/Off modes.

A-Steer Sensitivity

How much the steering wheel must move to disable Auto Steer.

NOTE: A larger sensitivity number means that the steering wheel will need to be turned farther and faster for Auto Steer to disengage.

NOTE: Auto Steer sensitivity (that forces Auto Steer off directly from steering wheel movement) may be adjusted when switching from floater tires to row crop tires, or vice versa.

To Change Auto Steer Setting Values

- Press the Auto Steer Button (located on the Settings Page).

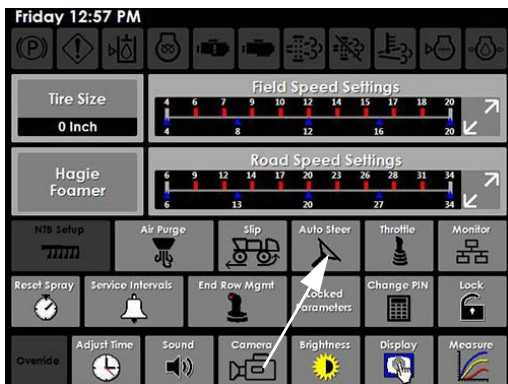

Auto Steer Button
(Located on the Settings Page)

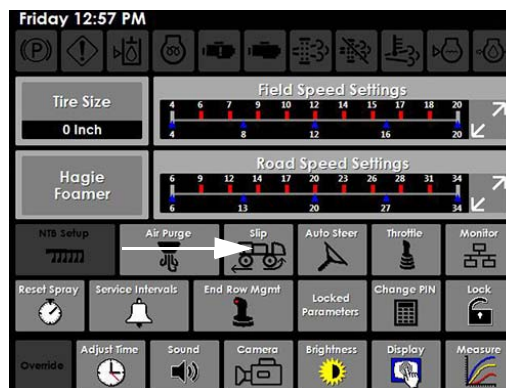

Slip Button
(Located on the Settings Page)

- On the “Auto Steer” screen, press EDIT (next to the desired Auto Steer setting).

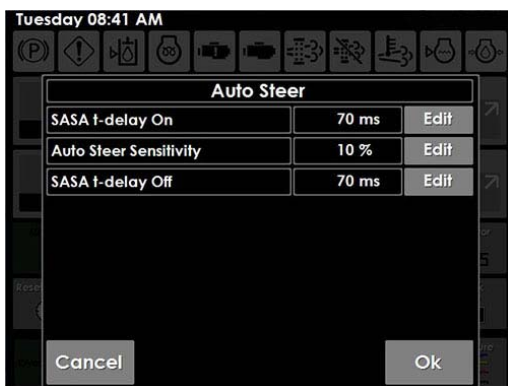

Auto Steer Screen

- Enter new value, then press ACCEPT.
- Press OK.

Slip (Traction Control)

To Activate Slip

- Press the Slip Button (located on the Settings Page).

- On the “Adjust Slip Parameters” screen, press NORMAL or SEVERE (depending on ground condition).

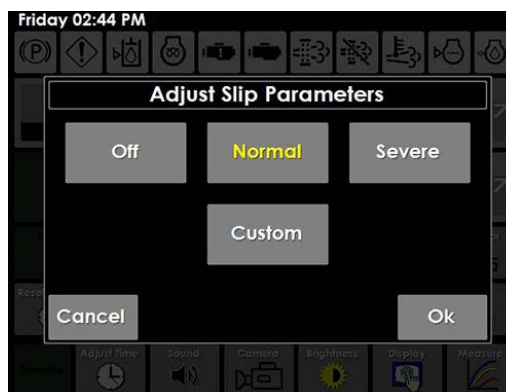

Adjust Slip Parameters Screen

- Press OK.

Custom Settings

Slip Percent

How much slip is allowed before traction control is activated.

- Press the Slip Button (located on the Settings Page).
- On the “Adjust Slip Parameters” screen, press CUSTOM.
- Press EDIT (next to Slip Percent).

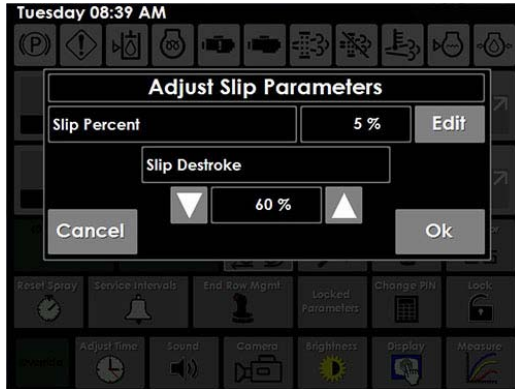

- Enter desired slip percentage value, then press OK.
- Press OK.

Slip Destroke

The percentage command that the wheel motors will ramp up to limit hydraulic flow.

NOTE: The higher the destroke number, the less the hydraulic flow will go to the slipping wheel motor.

- Press the Slip Button (located on the Settings Page).
- On the “Adjust Slip Parameters” screen, press CUSTOM.
- Press the Up/Down Arrow Buttons to obtain desired destroke value.

NOTE: Slip Destroke values are available in 20-percent increments.

- Press OK.

End Row Management

The End Row Management Switch (located on the Hydrostatic Drive Control Handle) may be programmed for use of various functions, including All-Wheel Steer, Auto Steer, Master Spray, and NORAC® Enable.

NOTE: End Row Management functions are disabled in Road Mode.

To Program the End Row Management Switch

- Press the End Row Management Button (located on the Settings Page).

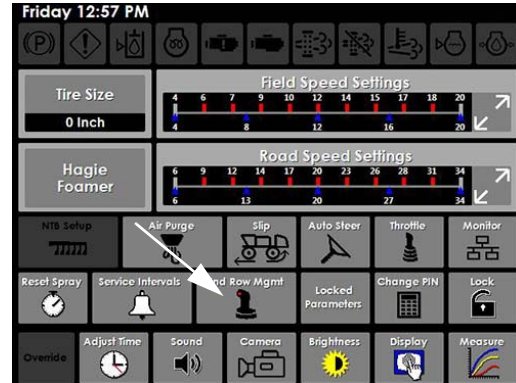

End Row Management Button
(Located on the Settings Page)

- On the “Select Action to Program” screen, select the setting in which you wish to operate the End Row Management Switch (located on the Hydrostatic Drive Control Handle) - “Single Press” or “Press and Hold”.

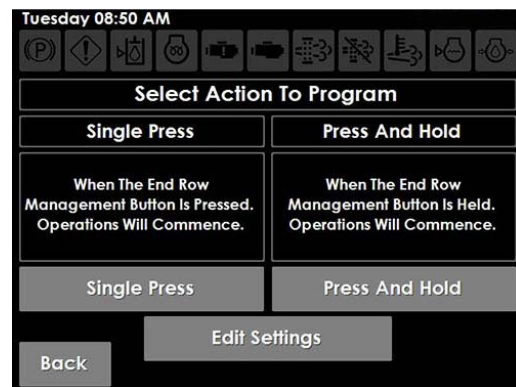

Select Action to Program Screen

- On the “End Row Management Editor” screen, press the “+” Button and select desired function (AWS, Auto Steer, Master Spray, or NORAC Enable).
- Press OK.

NOTE: Press the “-” Button to remove function.

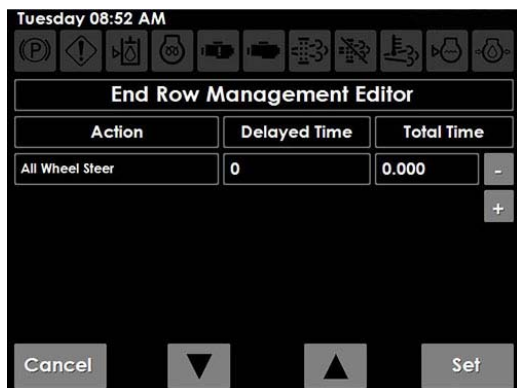

End Row Management Editor Screen

- Press SET.

Delayed Time and Total Time (Milliseconds)

Delayed Time

Press the “Delayed Time” display to adjust the time from when the End Row Management Switch (located on the Hydrostatic Drive Control Handle) is pressed to when the function is engaged.

Total Time

Displays the total time from when the End Row Management Switch is pressed until delayed time starts.

Example:

| | Delayed Time | Total Time | Time from when ERM Button is pressed to engagement |
|----|--------------|------------|--|
| 1. | 0 | 0 | 0 |
| 2. | 500 | 0 | 500 |
| 3. | 1,000 | 500 | 1,500 |
| 4. | 0 | 1,500 | 1,500 |

Edit End Row Management Settings

- On the “Select Action to Program” screen, press the Edit Settings Button.
- On the “End Row Management Settings” screen, press EDIT (next to desired End Row Management setting).
 - *Pause Before Activate*
 - *Display When Active*

- *Enable Single Press*
- *Enable Press and Hold*



End Row Management Settings Screen

- Enter desired value/setting, then press OK.
- Press OK.

Refer to “Spray Booms” provided in the *Spray Systems Section* elsewhere in this manual for information on setting up End Row Management NORAC Enable functions through the NORAC or Ag Leader display.

Foamer

-If Equipped

To Adjust Foam Frequency

- Press the Hagie Foamer Button (located on the Settings Page).

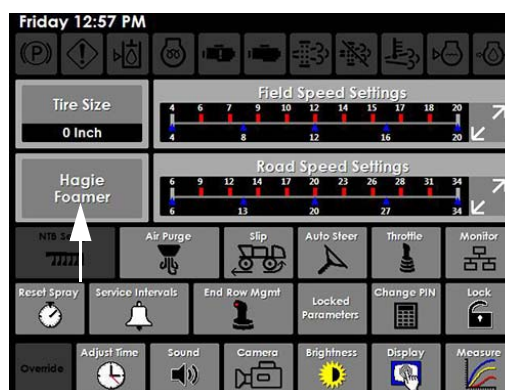

Hagie Foamer Button
(Located on the Settings Page)

- On the “Hagie Foamer” screen, press EDIT next to Total Flow.

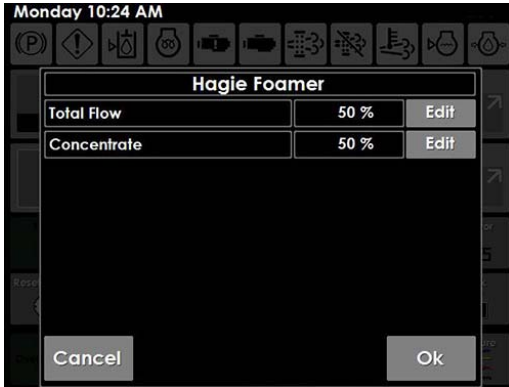

Hagie Foamer Screen

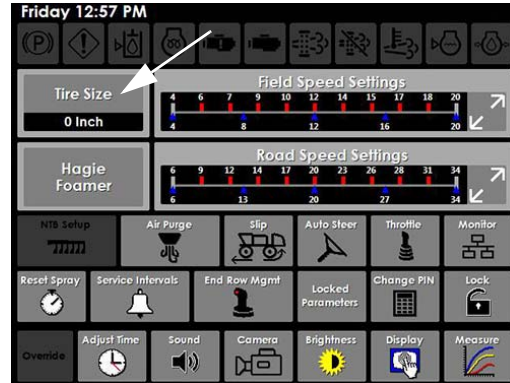

Tire Size Button
(Located on the Settings Page)

- Enter desired frequency value, then press OK.
- Press OK.

To Adjust Foam Concentrate

- Press the Hagie Foamer Button (located on the Settings Page).
- On the “Hagie Foamer” screen, press EDIT next to Concentrate.
- Enter desired concentration value, then press OK.
- Press OK.

Refer to “Foam Marker System” provided in the *Spray Systems Section* elsewhere in this manual for further information.

- On the “Rolling Circumference” screen, enter the tire rolling circumference.

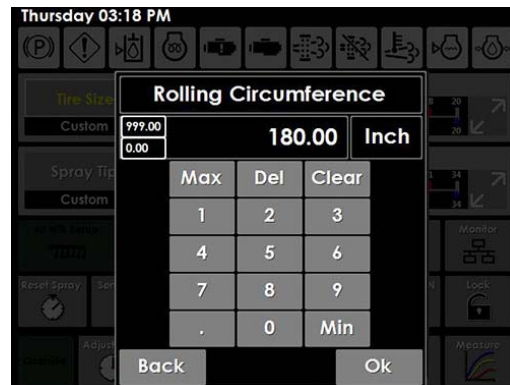

Rolling Circumference Screen

Tire Size

NOTE: Refer to “Tire Specifications” provided in the Introduction Section at the beginning of this manual for further information on tire options and the corresponding rolling circumference.

To Change Tire Size Value

- Press the Tire Size Button (located on the Settings Page).

- Press OK.

Air Purge

-If Equipped

The Air Purge feature on your machine allows you to blow out product from the spray system. You may choose to perform the air purge in either manual or automatic mode.

Manual Mode

In Manual Mode, the operator has control of the solution valves by manipulating the Boom Solution Valve Switches (located on the side console section keypad).

To Activate the Air Purge System in Manual Mode

- Ensure the Solution Pump Switch (located on the side console) is in the OFF position.

- Ensure the rinse, agitation, and solution tank valves are CLOSED.

NOTE: Press and hold the Agitation Valve Switch (located on the side console) in the DOWN position for approximately 10 seconds to ensure the agitation valve is closed.

NOTE: These valves do not need to be closed in order for the system to operate, but are required for the Air Purge to function properly.

- Press the Air Purge Button (located on the Auxiliary Controls Page).

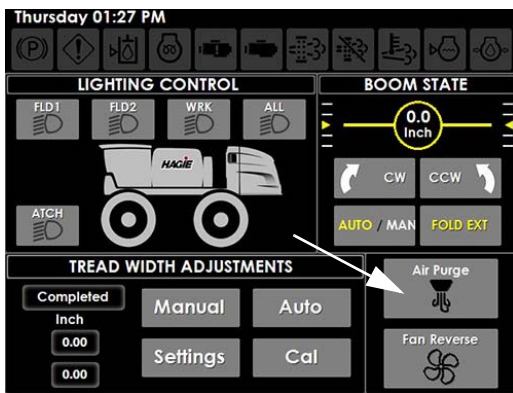

Air Purge Button

(Located on the Auxiliary Controls Page)

- On the “Air Purge” screen, press the Manual Button.

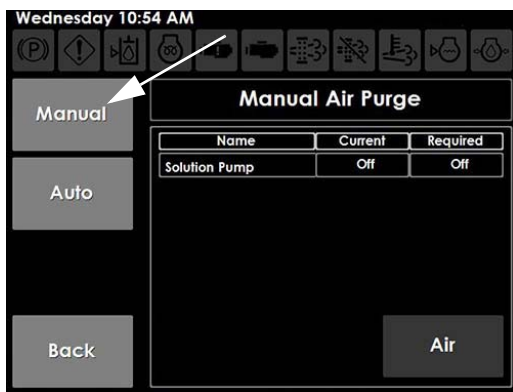

Air Purge Screen

- On the “Air Purge” screen, press the Air Button.

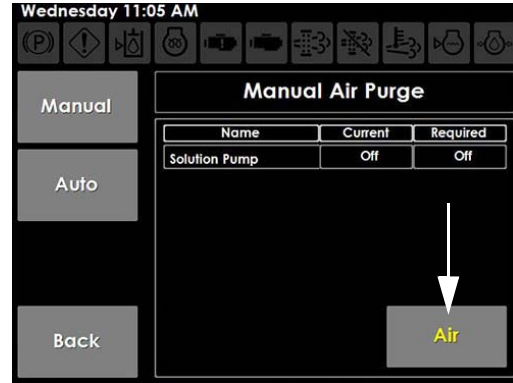

Air Purge Screen

NOTE: When the Air Button is depressed, it will open the air valve, releasing air into the solution system.

- Press the Master Spray Switch (located on the Hydrostatic Drive Control Handle) in the ON position.
- Press the desired Boom Solution Valve Switches (located on the side console) to blow air and product out of the spray system.

Automatic Mode

In Automatic Mode, the air tank on the machine is filled based on engine speed and time to automatically recharge the air tank and purge the spray system.

Automatic Air Purge Settings

(Full Boom Purge, Individual Section Purge, Air Recharge Time, and Minimum Engine Speed)

Full Boom Purge

- Press the Air Purge Button (located on the Settings Page).

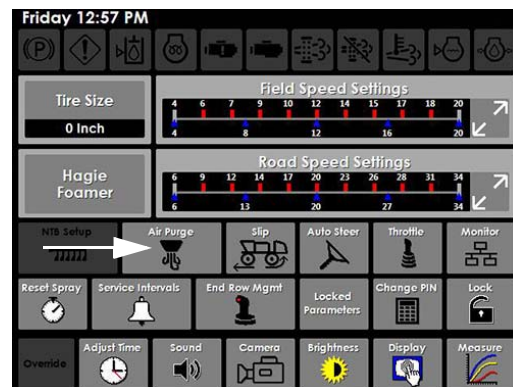

Air Purge Button

(Located on the Settings Page)

- On the “Air Purge Settings” screen, press EDIT (next to Full Boom Purge).

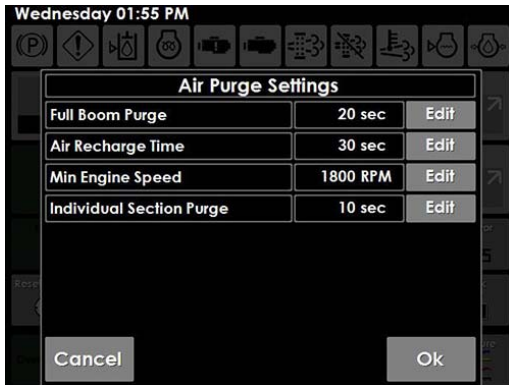

Air Purge Settings Screen

- Enter desired value (amount of time that the entire boom will purge), then press OK.
- Press OK.

Individual Section Purge

- Press the Air Purge Button (located on the Settings Page).
- On the “Air Purge Settings” screen, press EDIT (next to Individual Section Purge).
- Enter desired value (amount of time that each individual section will purge), then press OK.
- Press OK.

NOTE: When purging individual sections, the system will start with the leftmost section that is not turned off (on the section keypad) and continue to the rightmost section that is not turned off.

Example:

If Sections 1, 2, 8, and 9 are turned off and all others are on, then Sections 3-7 will be purged. The left fence row nozzle will be purged when Section 1 is purged (and full boom), and the right fence row nozzle will be purged when Section 9 is purged (and full boom), unless the fence row nozzles are turned off through the section keypad. The rear nozzle will purge with Section 5 (and full boom), unless the rear nozzle is turned off through the section keypad.

Air Recharge Time

- Press the Air Purge Button (located on the Settings Page).
- On the “Air Purge Settings” screen, press EDIT (next to Air Recharge Time).
- Enter desired value (amount of time that it takes to recharge the air tank), then press OK.
- Press OK.

Minimum Engine Speed

- Press the Air Purge Button (located on the Settings Page).
- On the “Air Purge Settings” screen, press EDIT (next to Minimum Engine Speed).
- Enter desired RPM, then press OK.

NOTE: Engine throttle must be above 1800 RPM. This will allow the air tank to recharge faster.

- Press OK.

To Activate the Air Purge System in Automatic Mode

- Ensure the Solution Pump Switch (located on the side console) is in the OFF position.
- Ensure the solution tank, rinse, and agitation valves are CLOSED.

NOTE: Press and hold the Agitation Valve Switch (located on the side console) in the DOWN position for approximately 10 seconds to ensure the agitation valve is closed.

- Throttle engine to desired RPM (above 1800 RPM).
- Ensure that no system faults are present.
- Press the Air Purge Button (located on the Auxiliary Controls Page).

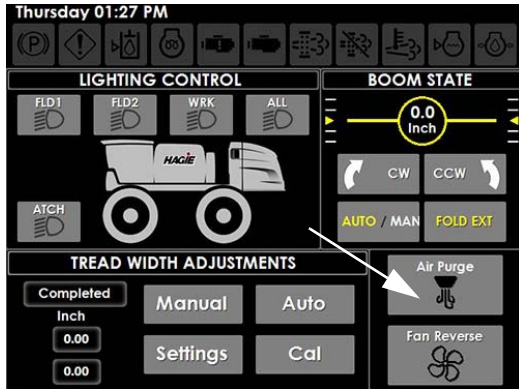

Air Purge Button
(Located on the Auxiliary Controls Page)

- On the “Auto Air Purge” screen, press the Auto Button and ensure all previous requirements have been met.

NOTE: Auto Air Purge will not activate until all requirements have been met.

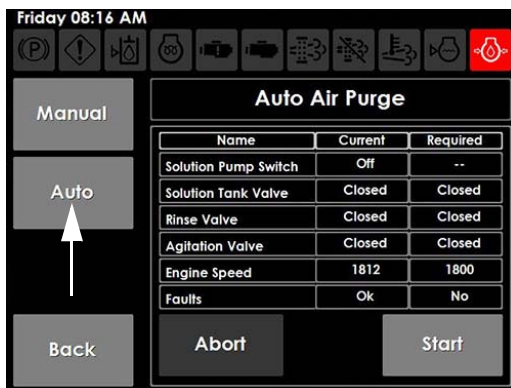

Auto Air Purge Screen

- Press the Start Button to begin purge.

NOTE: The Air Purge system will cycle as follows: full boom purge, air tank recharge, individual section purge. If the operator does not want a particular section to purge, press the corresponding Boom Solution Valve Switch (located on the side console section keypad) in the OFF position.

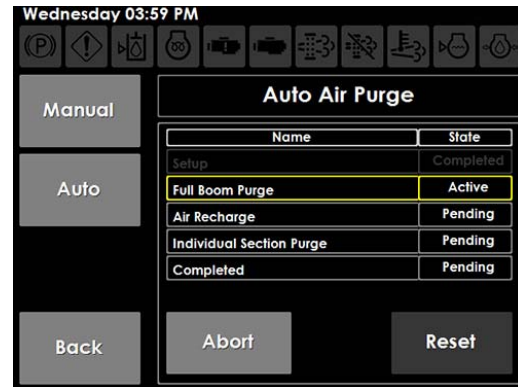

Air Purge Screen - Auto Cycle

NOTE: Press the Abort Button to stop air purge.

Hydraulic Tread Width Adjustment

-If Equipped

Hydraulic Tread Adjust allows the operator to change the tread width settings through the Machine Display inside the cab. Tread width may be adjusted in Manual Mode or Automatic Mode. Tread Calibration is also performed through the display.

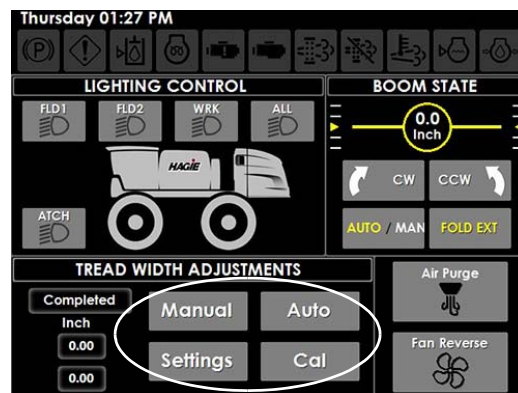

Tread Width Adjustment Buttons
(Located on the Auxiliary Controls Page)

Refer to “Tread Adjustment” provided in the *Hydraulic Systems Section* elsewhere in this manual for complete operating instructions and safety precautions.

System Gauges

(Engine Load, Fuel Rate, System Voltage)

Electronic System Gauges for machine Engine Load, Fuel Rate (gallons per hour), and System Voltage are located on the Machine Diagnostics Page. Digital display indicators are located beneath each System Gauge.

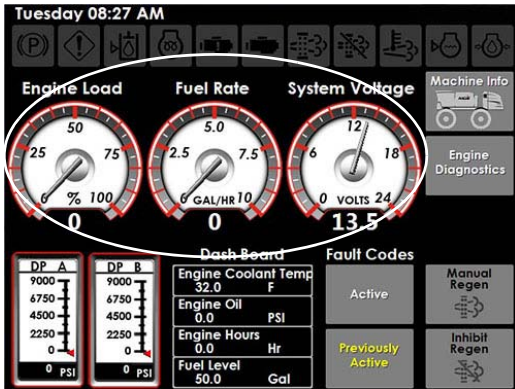

System Gauges
(Located on the
Machine Diagnostics Page)

NOTE: When battery voltage depletes to 11.7 volts and below, a warning message will appear alerting you of low battery voltage.

System Diagnostics

System Diagnostics may be viewed on the Machine Diagnostics Page. Such items include:

- Engine Coolant Temperature
- Engine Oil Pressure
- Engine Hours
- Fuel Level

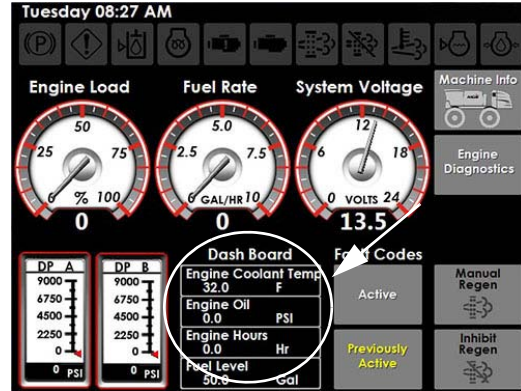

System Diagnostics
(Located on the
Machine Diagnostics Page)

When a service interval has been reached, a screen message will appear on the Machine Display informing you which service item requires attention.

Refer to the *Maintenance and Storage Section* elsewhere in this manual for information on recommended service intervals.

Engine Coolant Temperature

The Engine Coolant Temperature Gauge is located on the Machine Diagnostics Page. If the engine coolant temperature reaches a level that is too high (greater than 220° F.), a warning message will appear and a red indicator light will illuminate on the A-post temperature gauge. In addition, the warning buzzer will sound.

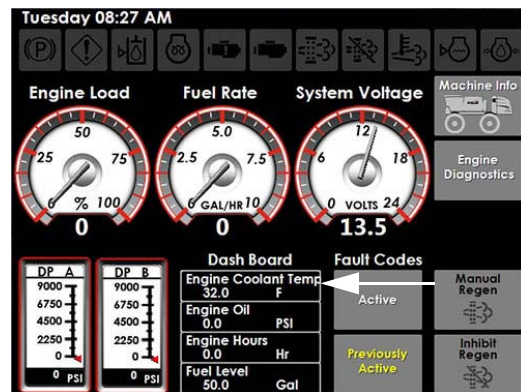

Engine Coolant Temperature Gauge
(Located on the
Machine Diagnostics Page)

NOTE: The warning buzzer may be silenced by pressing the Sound Button (located on the Settings Page).

If the engine temperature continues to rise after the initial warning message, a second warning message will appear shortly before the machine begins to go into protective mode, alerting you that the engine coolant temperature is too high and the engine will begin to de-rate. Press OK to acknowledge.

If this warning message appears, immediately reduce the engine speed and allow engine to idle. This will allow the cooling system to cool the engine down and prevent possible damage. Contact your local John Deere dealer if troubleshooting assistance is needed.

NOTE: When this warning message appears, the machine may be severely limited in engine and hydraulic functions (to prevent possible damage to those systems).

Engine Diagnostics

To View Current Engine Diagnostics

- Press the Engine Diagnostics Button (located on the Machine Diagnostics Page).

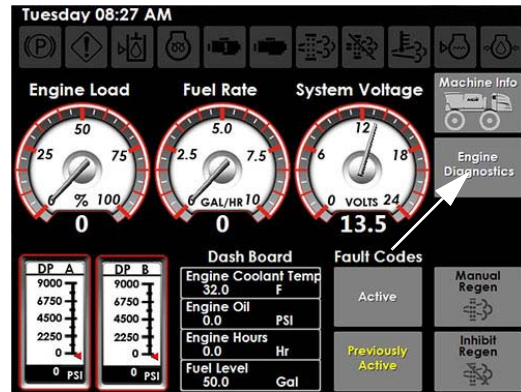

Engine Diagnostics Button
(Located on the
Machine Diagnostics Page)

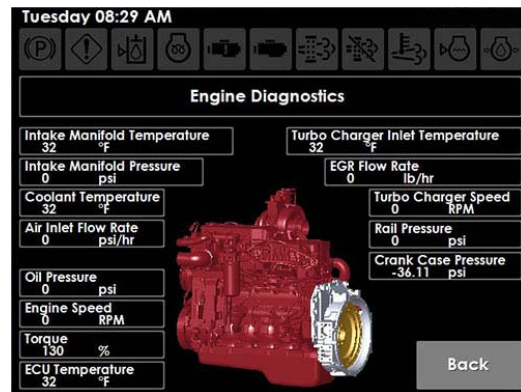

Engine Diagnostics Screen

DP-A/DP-B Gauges

The DP-A and DP-B Gauges (located on the Machine Diagnostics Page) displays current drive pump pressure.

- **DP-A** (Drive Pump, Port A) - High in forward acceleration.
- **DP-B** (Drive Pump, Port B) - High in forward or reverse deceleration.

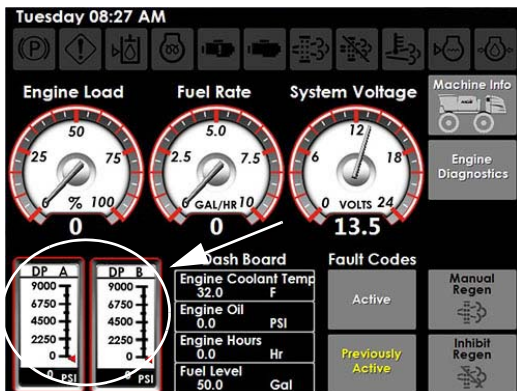

DP-A/DP-B Gauges
(Located on the
Machine Diagnostics Page)

CAN Monitor

(Controller Area Network)

The CAN Monitor on your machine is an analysis/communication tool used in combination with machine software, which allows you to view real-time data of machine systems. The CAN Monitor screen allows you to view CAN messages on each of the CAN networks.

CAN1/CAN2/CAN3

- CAN1 = Engine
- CAN2 = Primary/Secondary Controllers
- CAN3 = Diagnostics (Primary Controller)

NOTE: CAN3 by itself does not go to display and is CAN for third party systems.

Rx (Display Message “Received”)

Tx (Display Message “Transmitted”)

To View CAN Status

- Press the Monitor Button (located on the Settings Page).

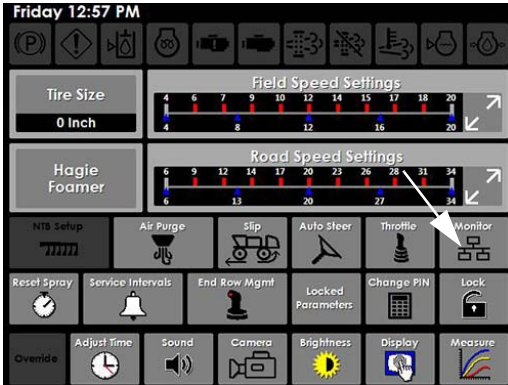

Monitor Button
(Located on the Settings Page)

- Press desired Enable CAN Button (Enable CAN1, Enable CAN2, or Enable CAN3) (located on the CAN Monitor screen) to view current CAN status.

NOTE: Press the Suppress Rx Button to remove “received” data before the Enable CAN Button is selected. Press the Suppress Tx Button to remove “transmitted” data before the Enable Can Button is selected.

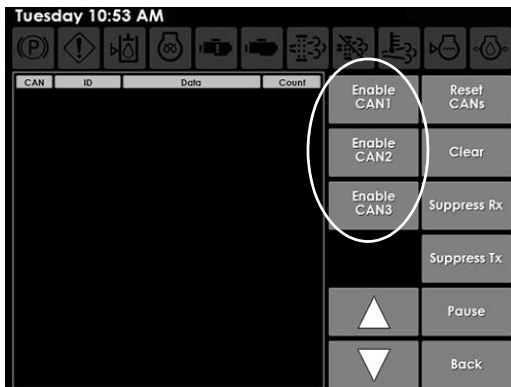

Enable CAN Buttons
(Located on the CAN Monitor Screen)

Wednesday 08:40 AM

| CAN | ID | Data | Count | | |
|-----|----------|----------------------|-------|-------------|-------------|
| Rx1 | 18FE400 | FF FF FF 00 FF FF FF | 6 | Enable CAN1 | Reset CANs |
| Rx1 | 18F0C00 | 00 FF 00 FF FF 00 FF | 6 | | |
| Rx1 | 18FE700 | FF FF FF 00 01 FF FF | 6 | | |
| Rx1 | 18FE200 | 00 00 FF FF FF FF FF | 6 | Enable CAN2 | Clear |
| Rx1 | 0CF00300 | FF FF 00 FF FF FF FF | 6 | | |
| Rx1 | 0CF00400 | FF FF 00 00 FF FF FF | 6 | | |
| Rx1 | 18FECA00 | 10 FF 00 00 FF FF FF | 3 | | |
| Rx1 | 18FE500 | 00 00 00 FF FF FF FF | 6 | Enable CAN3 | Suppress Rx |
| Rx1 | 18FEE00 | 28 FF FF FF FF FF FF | 6 | | |
| Rx1 | 18FE100 | FF FF FF 00 FA 00 FF | 6 | | |
| Tx1 | 18FE120 | FF FF FF FF FF FF 3F | 40 | | |
| Tx1 | 18FEFC27 | FF 50 FF FF FF FF FF | 16 | | Suppress Tx |
| Tx1 | 18E0020 | FF FF FF FF FF 00 FF | 4 | | |
| Tx2 | 18FF62A | FF FF FF 00 FF FF FF | 2 | | |
| Tx2 | 18FF72A | FF FF FF FF FF FF FF | 2 | | |
| Rx2 | 18FF328 | FF FF 00 FF FF FF FF | 2 | | |
| Rx2 | 18FF928 | 00 00 00 00 00 00 FF | 2 | | |
| Rx2 | 18FFA28 | FF FF FF FF FF FF FF | 2 | | |
| Rx2 | 18FFB28 | FF FF FF FF FF FF FF | 2 | | |
| Rx2 | 18FFC28 | FF FF FF FF FF FF FF | 2 | | |

CAN Status

- Press the Pause Button at any time to pause the monitor.
- Press the Up or Down Arrow Buttons to navigate through the CAN pages individually.
- Press the Reset CANs Button to reset all CAN data.
- Press the Clear Button to clear the current screen.
- Press the Back Button to revert back to the Settings Page.

Measure

While either parked or operating the machine, current system measurements can be viewed when diagnosing or troubleshooting.

- Press the Measure Button (located on the Settings Page).

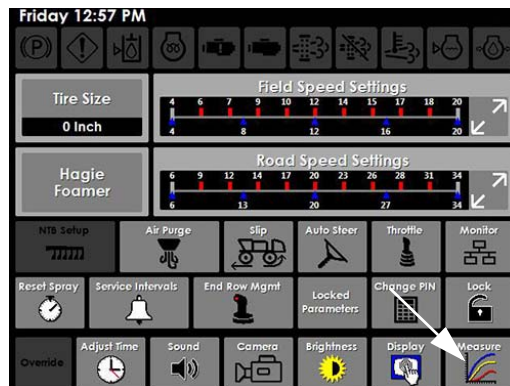

Measure Button
(Located on the Settings Page)

- Select system.
- On the “Press to Select Signals to Measure” screen, press the UP or DOWN

Arrow Buttons to toggle to desired parameters.

NOTE: Single arrow buttons toggle up/down one page. Double arrow buttons toggle to either the first or last page.

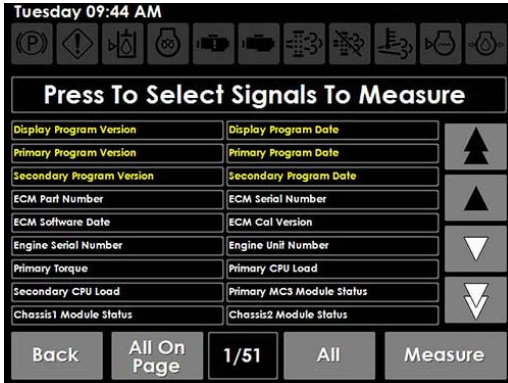

Press to Select Signals to Measure Screen

- Select desired system(s).

NOTE: Multiple signals may be selected and viewed simultaneously.

- Press MEASURE to view current signal measurements.

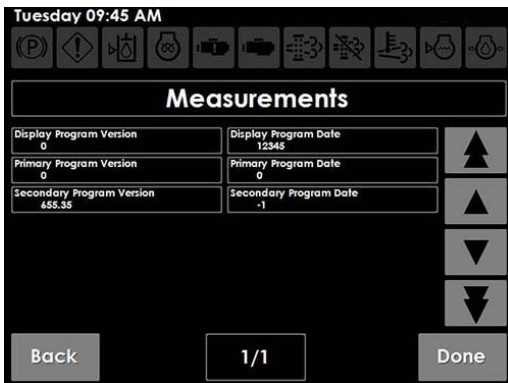

Measurement Screen

- Press BACK to revert to previous page and add or remove signals.
- Press DONE when finished.

System Faults

When a System Fault occurs, a warning message will appear on any given display page, which will inform you of the fault code and reason for the fault. Press OK to acknowledge.

Each System Fault will display the following:

1. **LAMP** (severity of fault)
 - Blue = Informational
 - Yellow = Caution
 - Red = Warning (shut down engine immediately)
2. **FAULT CODE** (refer to fault code when speaking with your local John Deere dealer)
3. **DESCRIPTION** (fault description)
4. **OCCURENCE** (number of fault occurrences)
5. **TIME** (time fault occurred)

To View System Faults:

- Press the desired “Active” or “Previously Active” Fault Code Button (located on Machine Diagnostics Page).

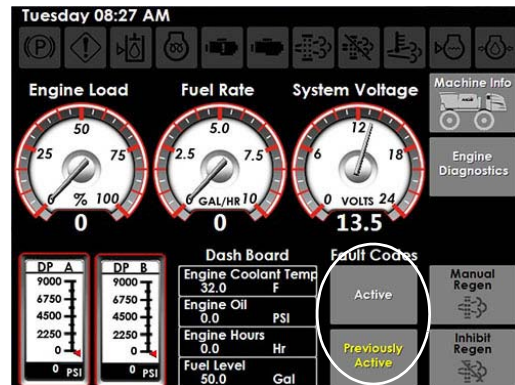

Fault Code Buttons (Located on the Machine Diagnostics Page)

- On the “System Faults” screen, press the Up/Down Buttons to toggle to desired fault.

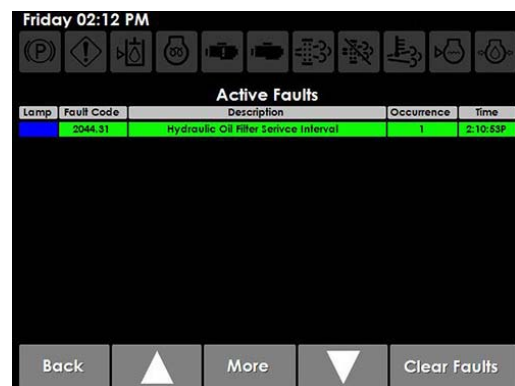

System Faults Screen

- Press the More Button to display fault description.
- Press the Clear Faults Button to remove faults after the fault issue has been resolved.
- Press OK to confirm.

NOTE: System Faults will continue to appear until the fault issue has been resolved, regardless of clearing the faults.

In the event that a severe system malfunction should occur and cause the machine to operate outside of normal operating conditions (e.g. All-Wheel Steer fault, Hydrostatic Drive Control Handle not in neutral but has no y-axis position, tire size not selected, etc.), a Machine Fault Warning message will appear on the display. This warning message will inform you that a malfunction was detected and that the machine is not responding normally and you must operate with extreme caution, as machine speed will be limited and stopping distance may be increased or decreased. Press OK to acknowledge.

In addition, a second warning message will appear informing you of the specific fault description. Contact your local John Deere dealer for assistance.

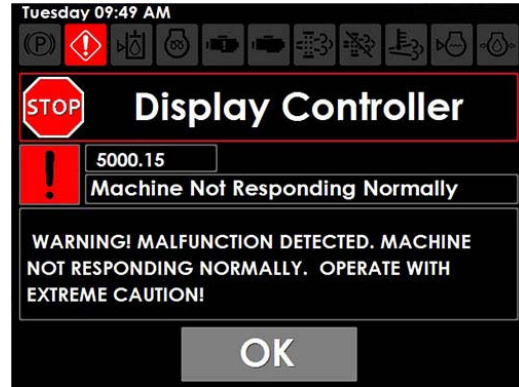

Machine Fault Warning

Reversible Fan

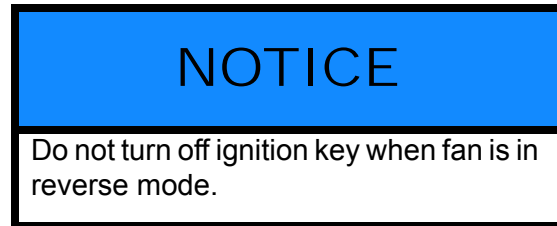

To Activate the Reversible Fan

- Press the Reversible Fan Button (located on the Auxiliary Controls Page).

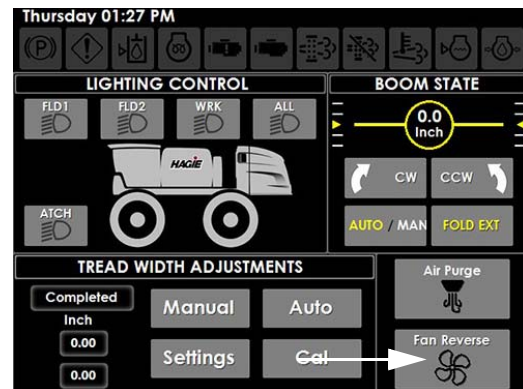

Reversible Fan Button
(Located on the Auxiliary Controls Page)

- On the “Engine Fan Control” screen, press REVERSE to turn the fan ON (reverse).

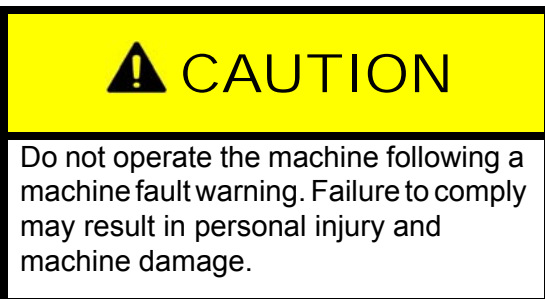
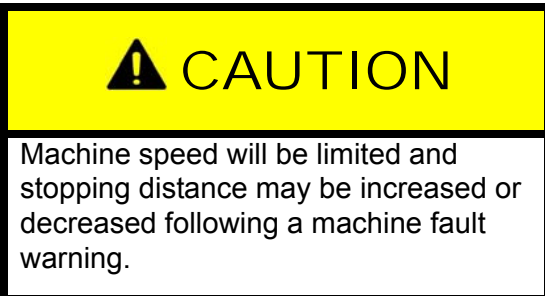

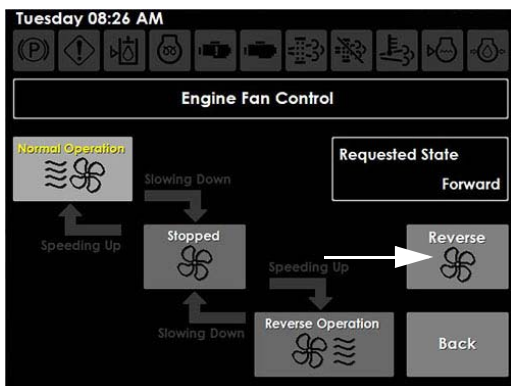

Engine Fan Control Screen

NOTE: During the reverse cycle, the “Engine Fan Control” screen will display the current state of the reversible fan (Normal Operation, Stopped, or Reverse Operation) and will let you know if the fan is slowing down or speeding up. The fan will automatically return to Normal Operation when the reverse cycle is complete.

Refer to “Reversible Fan” provided in the *Hydraulic Systems Section* elsewhere in this manual for further information.

Spray System Indicators

- Rinse Mode Indicator
- Solution Pump Indicator
- Master Spray Indicator

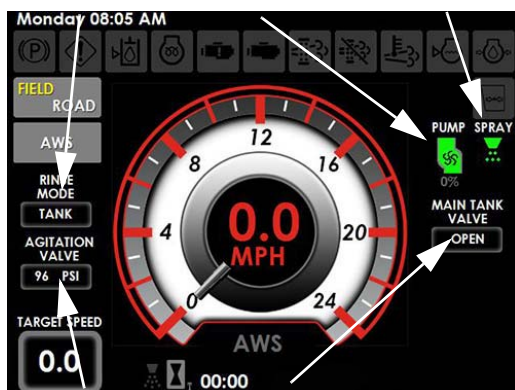

- Agitation Valve Pressure Indicator
- Main Tank Valve Indicator

Spray System Indicators
(Located on the Home Page - Field Mode)

Solution Pump Indicator

When the Solution Pump Switch (located on the side console) is turned ON, a Solution Pump Indicator (located on the Home Page - Field Mode) will illuminate.

NOTE: When the Solution Pump Switch and the Manual (MAN) Rate Control Switch (located on the side console) are both enabled, the pump speed is displayed below the Solution Pump Indicator. Press the “+” or “-” Pump Speed/Rate Switch (located on the side console) to increase or decrease solution pump speed.

Master Spray Indicator

When the Master Spray Switch (located on the Hydrostatic Drive Control Handle) has been activated, a Master Spray Indicator (located on the Home Page - Field Mode) will illuminate.

Main Tank Valve Indicator

When the Main Tank Valve Switch (located on the side console) is activated, the Main Tank Valve Indicator (located on the Home Page - Field Mode) will display OPEN. When the switch is not activated, the Main Tank Valve Indicator will display CLOSED.

Rinse Mode Indicator

When the Rinse Switch (located on the side console) is activated, the Rinse Mode Indicator (located on the Home Page - Field Mode) will display either OFF, BOOM, or TANK.

Agitation Valve Pressure Indicator

The Agitation Valve Switch (located on the side console) controls the rate of flow through the Agitation System. Agitation pressure is displayed on the Home Page - Road and Field Mode.

Spray Booms

Boom State - Auto/Manual (120’/132’ Spray Booms)

Press the Boom State Button (located on the Auxiliary Controls Page) to the AUTO or MANUAL position.

NOTE: The selected boom state will illuminate.

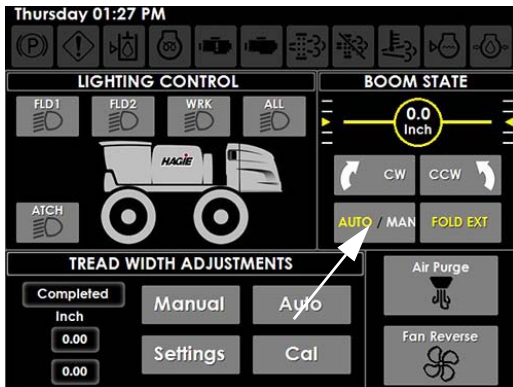

Boom State Buttons - Auto/Manual
 (Located on the Auxiliary Controls Page)

Boom Extensions - Auto Fold

To operate the Boom Extensions in Auto mode:

- Press the Boom State Button (located on the Auxiliary Controls Page) to the AUTO (illuminated) position.
- Press the Fold Ext Button (located on the Auxiliary Controls Page) to the ON (illuminated) position to enable Auto Fold operation.

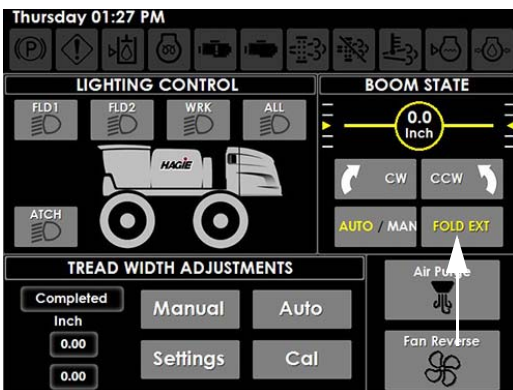

Fold Extension Button
 (Located on the Auxiliary Controls Page)

- Operate the Left and Right Boom Extension Switches (located on the side console) to desired position.

Refer to the *Spray Systems Section* elsewhere in this manual for further information.

Boom Alignment (120'/132' Spray Booms)

When operating boom functions, the Boom Alignment value may be viewed on the Auxiliary Controls Page.

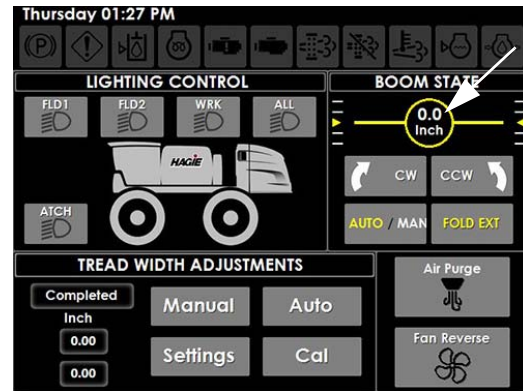

Boom Alignment Value
 (Located on the Auxiliary Controls Page)

Rolling Boom (120'/132' Spray Booms)

The Roll Command Buttons (located on the Auxiliary Controls Page) will enable the boom to roll either “clockwise” or “counter-clockwise” (as viewed from the cab).

- Press and hold the “CW” Roll Command Button to roll the boom “clockwise”.
- Press and hold the “CCW” Roll Command Button to roll the boom “counter-clockwise”.

NOTE: The Roll Command Buttons will illuminate when held in the ON position and the current boom alignment value will be displayed.

- When either of the CW or CCW Roll Command Buttons are released, the boom will return to the neutral (center) position.

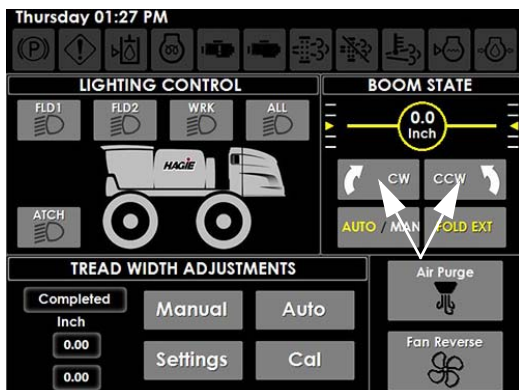

Roll Command Buttons (CW/CCW)
(Located on the Auxiliary Controls Page)

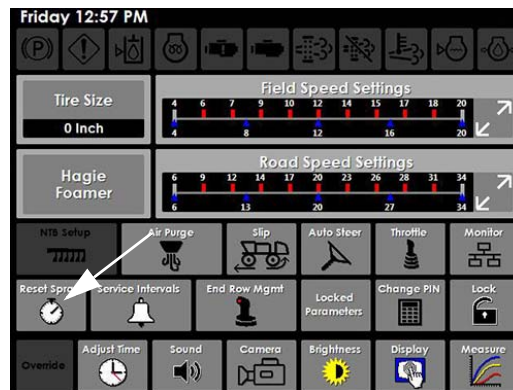

Reset Spray Button
(Located on the Settings Page)

NOTE: Center position value is 0 inches/cm.

Refer to the *Spray Systems Section* elsewhere in this manual for further information.

Spray Application Time Indicator

The current amount of spray application time is displayed on the bottom of the Home Page - Field Mode.



Spray Application Time Indicator
(Located on the Home Page - Field Mode)

Reset Total Spray Time

- Press the Reset Spray Button (located on the Settings Page) to reset the total spray time.

- Press OK.

Nitrogen Toolbar (NTB/HsTB)

-If Equipped

Float

The Float Button (located on the Auxiliary Controls Page) is used to enable Float operation.

- Press the Float Button to turn Float ON. Press button again to turn Float OFF.

NOTE: The Float Button will illuminate when in the ON position.

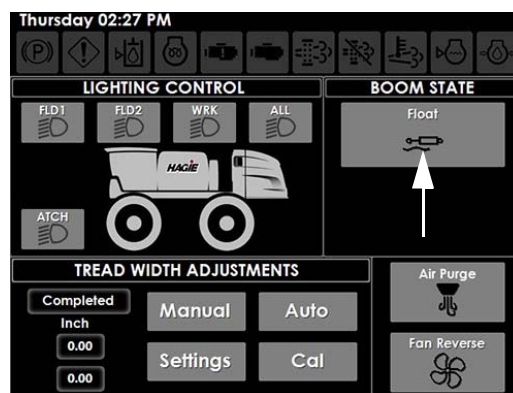

Float Button
(Located on the Auxiliary Controls Page)

NTB/HsTB Setup

- Press the NTB Setup Button (located on the Settings Page).

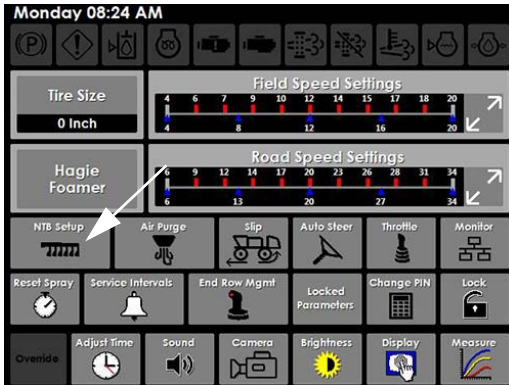

NTB Setup Button
(Located on the Settings Page)

- On the “NTB Adjustments” screen, press EDIT (next to desired selection - *NTB Override Timer, Float with Transom Down, or One Tap Transom Up*).



NTB Adjustments Screen

- Enter/select desired setting, then press OK.
- Press OK.

Further Information

Refer to your NTB operator’s manual for complete feature descriptions and operating instructions.

WARNING

CALIFORNIA PROPOSITION 65 WARNING

WARNING: Diesel engine exhaust and some of its constituents are known to the State of California to cause cancer and birth defects or other reproductive harm.

WARNING: Battery posts, terminals, and related accessories contain lead and lead compounds, and chemicals known to the State of California to cause cancer and birth defects or other reproductive harm.



Insufficient Cab Air Pressure Indicator
(Located on the Machine Display Home Page - Road or Field Mode)

ENGINE - STARTING

CAUTION

Start engine from the operator's seat only. When running the engine in a building, ensure there is adequate ventilation.

NOTE: An Insufficient Cab Air Pressure Indicator will appear on the Machine Display Home Page - Road or Field Mode each time the machine is started, due to a slight activation delay of the RESPA® Cab Filtration System. The indicator will disappear once the cab becomes pressurized.

Pre-Operational Checklist

1. Check engine oil level.

NOTE: Do not operate the machine when oil level is below the "L" (low) mark or above the "H" (high) mark on the engine oil dipstick.

2. Check engine coolant level.
3. Check diesel exhaust fluid level (Final Tier 4 engines).
4. Check hydraulic reservoir oil level.
5. Check cooling air intake screen.
6. Drain fuel/water separator.
7. Check engine drive belt.
8. Drain water out of the air tank.
9. Check for any oil or fuel leaks.

Cold Weather Starting

Your engine is equipped with an Engine Block Heater to aid in cold weather starting. Refer to the engine manufacturer's user manual for further information.



Engine Block Heater Power Cord
(Located beneath machine along
the right-hand side of engine)
-Typical View

* View looking from rear to front of machine

Jump Starting

1. Engage the parking brake.
2. Rotate the Battery Disconnect Switch (located inside the engine compartment on rear right-hand side of machine - open hood to access) to the ON position.

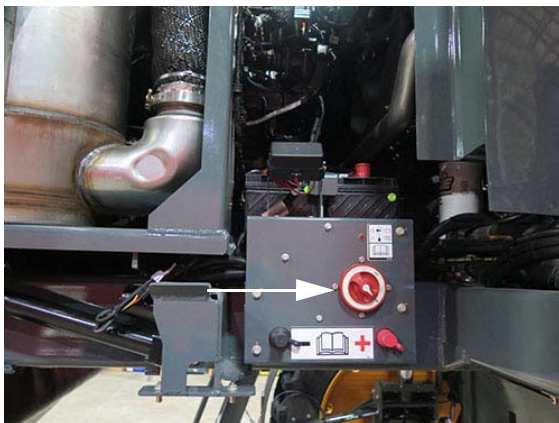

Battery Disconnect Switch
(Located inside engine compartment
on rear right-hand side of machine
- open hood to access)
-Typical View

3. Remove caps from the Auxiliary Battery Charging Posts (located in the engine

compartment on rear right-hand side of machine - open hood to access).

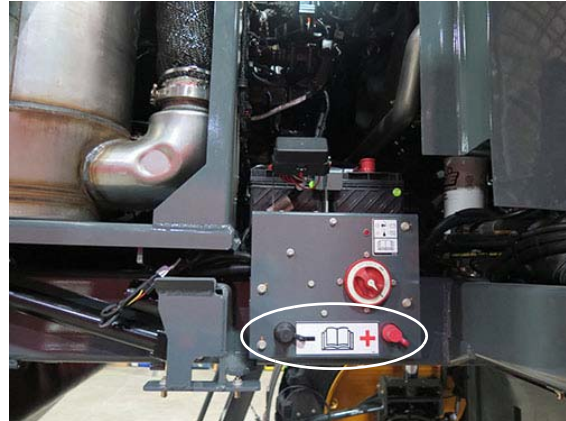

Auxiliary Battery Charging Posts
(Located inside engine compartment
on rear right-hand side of machine
- open hood to access)
-Typical View

4. Connect cables from charging device (i.e. battery charger or another machine) to the Auxiliary Battery Charging Posts - positive cable to the positive terminal, and negative cable to the negative terminal.
5. Allow batteries to charge approximately 5-10 minutes.

NOTICE

Do not over-crank the starter. Failure to comply may result in starter damage.

6. Engage the starter by starting the machine.
7. Remove the charging cables in reverse to the way you attached them (negative cable first, then positive cable).

NOTE: Ensure that the charging cables do not touch together or to any metal surface.

8. Reinstall the Auxiliary Battery Charging Post caps.
9. Allow engine to idle for approximately 5 minutes to recharge the batteries.

NOTE: Longer idle time may be required, depending on how depleted the batteries are.

ENGINE AFTERTREATMENT - FINAL TIER 4

WARNING

It is unlawful to tamper with or remove any component of the Aftertreatment System. It is also unlawful to use Diesel Exhaust Fluid (DEF) that does not meet the specifications provided or to operate the machine with no DEF.

WARNING

DEF contains urea. Do not get the substance in your eyes. In case of contact, immediately flush eyes with large amounts of water for a minimum of 15 minutes. Do not swallow internally. In the event the DEF is ingested, contact a physician immediately.

WARNING

Read the DEF manufacturer's label and comply with safety precautions to avoid injury or damage.

CAUTION

Never attempt to create DEF by mixing agricultural grade urea with water. Agricultural grade urea does not meet the necessary specifications required and the Aftertreatment System may be damaged.

CAUTION

Aftertreatment DOC and DRT components may be hot. Allow engine to cool before handling. Failure to comply may result in injury.

CAUTION

Never add water or any other fluid besides what is specified to the DEF tank. Failure to comply may result in Aftertreatment System damage.

CAUTION

Do NOT add any chemicals/additives to the DEF in an effort to prevent freezing. If chemicals/additives are added to the DEF, the Aftertreatment System may become damaged.

CAUTION

When performing a stationary exhaust system cleaning, ensure the exhaust pipe outlet is not directed at any surface or material that may become hazardous.

NOTICE

USE CORRECT FLUID TYPES

- Use only low-ash diesel engine oil.
- Use only ultra-low sulfur diesel (ULSD) fuel.
- Use only DEF meeting ISO 2224101 standards.

Failure to use the required fluid types will result in engine damage and will void the warranty.

NOTICE

Never operate the engine with low DEF level.

NOTICE

Do not direct water into exhaust opening. Failure to comply may result in system damage and will void the warranty.

NOTICE

DEF CAN BE CORROSIVE TO CERTAIN MATERIALS

- Use only approved containers to transport or store DEF (polyethylene and polypropylene containers recommended).
- If DEF is spilled, rinse and clean immediately with water.
- Avoid contact with skin. If contact occurs, wash off immediately with soap and water.

NOTICE

Wipe up spills immediately with clean water. If DEF is left to dry, a white residue will remain. Failure to clean spilled DEF appropriately may result in an incorrectly diagnosed leak of the DEF Dosing System.

NOTICE

Thoroughly wash any containers, funnels, etc. that will be used to dispense, handle, or store DEF. **Rinse with distilled water only.** Use of tap water to rinse components will contaminate the DEF.

NOTICE

If incorrect fluid is mistakenly added to the DEF tank (e.g. water, diesel fuel, hydraulic oil, engine coolant, windshield washer fluid, etc.), contact the engine manufacturer to determine the appropriate repair.

The Final Tier 4 diesel engine is featured with a flow-through exhaust Aftertreatment System that delivers ultra-low emissions for cleaner air quality.

NOTE: When the ignition key is turned to the OFF position, DEF returns to the DEF tank.

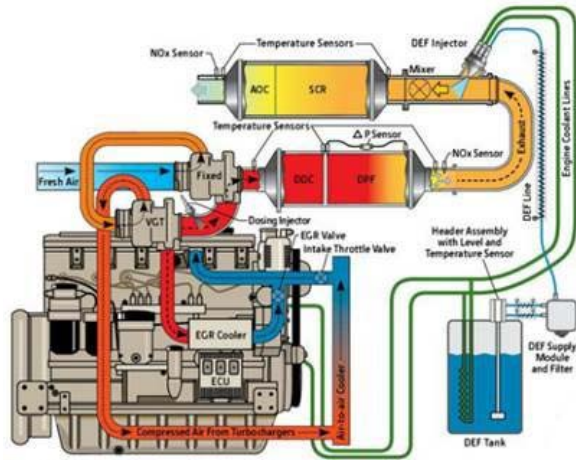

PowerTech PSS 9.0L and 13.5L engine configuration shown.

Engine Aftertreatment System

Aftertreatment System Components

- Final Tier 4 Diesel Engine
- Diesel Exhaust Fluid (DEF) Tank
- Diesel Exhaust Fluid (DEF) Gauge
- Diesel Oxidation Catalyst (DOC)
- Diesel Particulate Filter (DPF)
- Decomposition Reactor Tube (DRT)
- Selective Catalytic Reduction (SCR)
- DEF Dosing Module
- DEF Supply Module
- DEF Supply Module Filter
- DEF Quality Sensor
- DEF Suction Strainer
- Final Tier 4 Engine Indicator Light

Final Tier 4 Diesel Engine



Final Tier 4 Diesel Engine
(Located near rear of machine
- open hood to access)
-Typical View

DEF Tank

- DEF Tank Capacity = 7.8 gallons (29.5L)

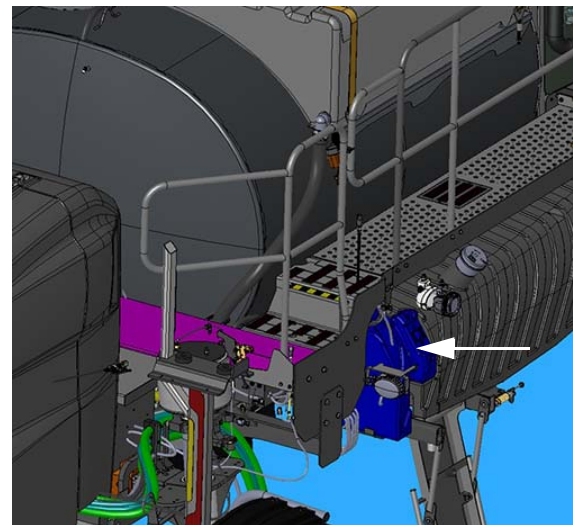

DEF Tank
(Located on right-hand side
of machine near fuel tank)
-Typical View

DEF (Diesel Exhaust Fluid)

DEF is used in Selective Catalyst Reduction (SCR) systems to aid in converting nitrogen oxide (NOx) emissions in engine diesel exhaust into harmless nitrogen and water vapor.

NOTE: Check DEF level daily.

Fluid Type:

- Use only DEF which meet ISO 2224101 standards.

NOTE: John Deere Diesel Exhaust Fluid recommended.

Fluid Storage:

- Store DEF between 23° F (-5° C) and 77° F (25° C).
- Refer to “Service - Fluids” provided in the *Maintenance and Storage Section* elsewhere in this manual for additional information.

Fluid Disposal:

- Check with local authority regulations on proper DEF disposal requirements.

DEF Gauge

The DEF Gauge (located on the cab A-post) allows the operator to view current DEF tank level at all times.



DEF Gauge
(Located on cab A-post)
-Typical View

DOC (Diesel Oxidation Catalyst)

The DOC reacts with exhaust gases to reduce carbon monoxide, hydrocarbons, and some particulate matter (PM).

DPF (Diesel Particulate Filter)

The DPF traps and holds the remaining particulate matter (PM) produced by the engine. Trapped particles are oxidized within the DPF through a continuous cleaning process called “passive regeneration”.

DRT (Decomposition Reactor Tube)

The DRT is a mixer tube where DEF is injected and mixes with exhaust from the diesel engine, which is then converted into ammonia.

SCR (Selective Catalytic Reduction)

The SCR is where the DEF reduces gaseous nitrogen oxide (NOx) to near zero levels by converting into nitrogen gas and water vapor.

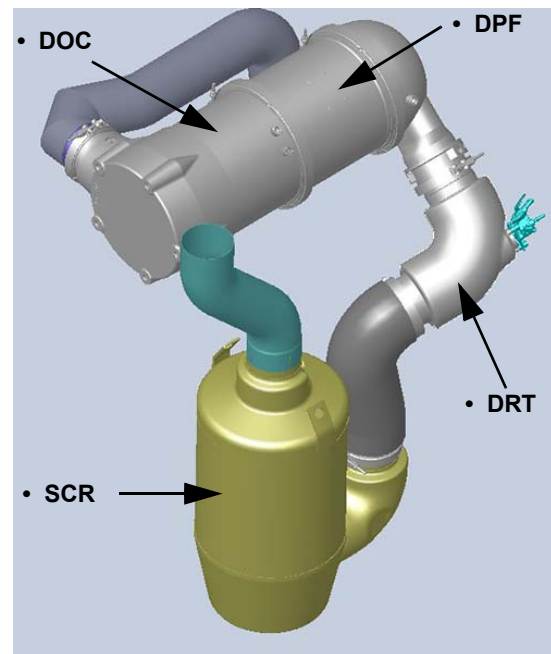

-Typical View

DEF Dosing Module

The DEF Dosing Module allows a fine mist of DEF to be sprayed into the hot exhaust.

DEF Supply Module

The DEF Supply Module (located on the back side of the DEF Tank) pumps DEF from the tank to the Dosing Injector (located in the DRT).

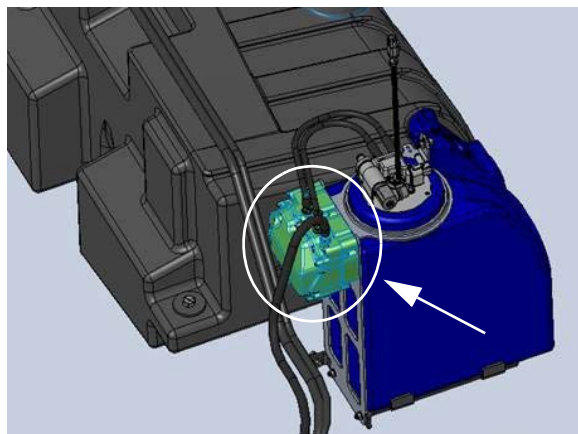

DEF Supply Module
(Located on back side of DEF Tank)
-Typical View

DEF Supply Module Filter

The DEF Supply Module Filter (located beneath DEF Supply Module - access from underside of machine) filters DEF before going to the Dosing Injector. Replace filter every 4,500 hours of operation or every 3 years, whichever occurs first.

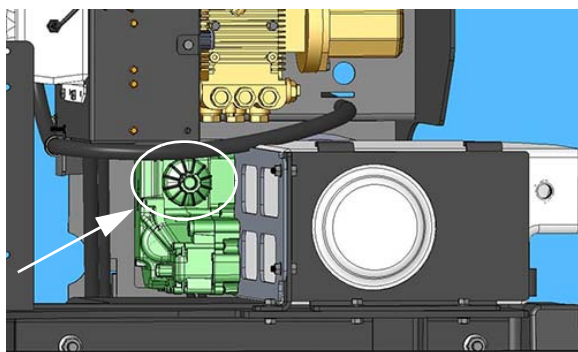

DEF Supply Module Filter
(Located beneath DEF Supply Module -
access from underside of machine)
-Typical View

DEF Quality Sensor

The DEF Quality Sensor (located inside the tank) detects DEF tank level, as well as quality and temperature of the DEF, which are required for the Aftertreatment System to function properly.

DEF Suction Strainer

The DEF Tank is equipped with a Suction Strainer (located near bottom of tank). If degraded system performance occurs, remove drain plug (located at bottom of tank) to drain sediment from tank. Remove and clean Suction Strainer, ensuring the strainer is reinstalled correctly when finished.

NOTE: Flush DEF Tank and components with distilled water only to remove any contamination. Refer to the engine manufacturer's operation manual for further information.

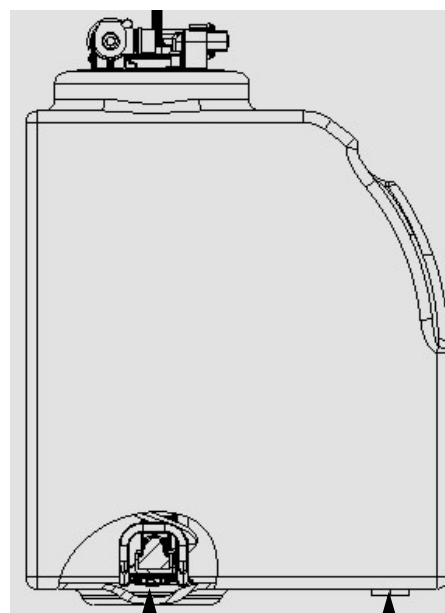

• DEF Suction Strainer
• DEF Tank Drain Plug

DEF Suction Strainer and Drain Plug
(Located near bottom of DEF Tank)
-Typical View

Final Tier 4 Engine Indicator Light

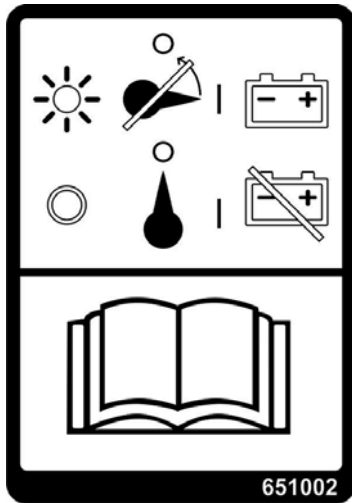

DO NOT TURN BATTERY DISCONNECT SWITCH OFF WHEN FINAL TIER 4 INDICATOR LIGHT IS ILLUMINATED

The Final Tier 4 Engine Indicator Light is located near the Battery Disconnect Switch and will flash (after the ignition key is shut off) until the DEF Recirculation Pump has finished running.

Refer to “Battery Disconnect Switch” provided in the *Electrical Systems Section* elsewhere in this manual for further information.

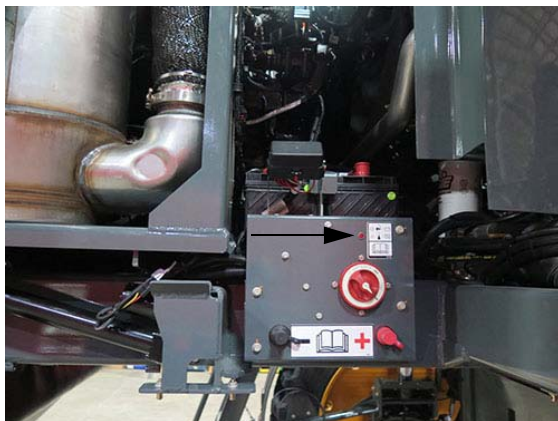

Final Tier 4 Engine Indicator Light
(Located near the
Battery Disconnect Switch)
-Typical View

Filling the DEF Tank

DEF Indicator Lamps (Located on the Machine Display)



- **DEF Indicator Lamp** - Illuminates when the DEF level is low, and flashes when the DEF falls below a very low level. Operator should refill the DEF tank with DEF.



- **Flashing DEF Indicator Lamp with Check Engine Indicator Lamp** - Illuminates when the DEF level is critically low. If the tank is not refilled immediately, power will be reduced. Operator should refill the DEF tank with DEF. Normal engine power will be restored after the DEF tank is refilled.

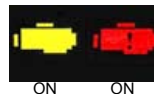

- **Flashing DEF Indicator Lamp with Stop Engine Indicator Lamp** - Illuminates when the DEF gauge reads zero. Power will be reduced or limited to idle. Operator should stop the machine when it is safe to do so and refill the DEF tank. Normal engine power will be restored once the DEF tank is refilled.

NOTE: Your machine is featured with a fuel fill ladder (located beneath the fuel tank on the right-hand side of machine) for ease in accessing the fuel and diesel exhaust fluid (DEF) tank fill ports. Refer to “Ladder - Fuel Fill” provided in the *Miscellaneous Section* elsewhere in this manual for further information.

1. Shut the engine OFF.
2. Remove DEF Fill Cap (located on front of DEF tank) and set aside.



DEF Fill Cap
(Located on front of DEF tank)
-Typical View

3. Fill tank with DEF.
4. Reinstall DEF Fill Cap.

NOTE: Refill tank with DEF every other fuel fill.

Stationary Exhaust System Cleaning

Your Final Tier 4 diesel engine requires little or no operator interaction. Under certain circumstances, an operator-initiated Exhaust System Cleaning may be required. Exhaust System Cleaning Indicator Lamps (located on the Machine Display) will illuminate to show system status.

Exhaust System Cleaning Indicator Lamps

(Located on the Machine Display)



- **High Exhaust System Temperature (HEST) Indicator Lamp** - May illuminate due to higher than normal exhaust temperature during Exhaust System Cleaning. Operator should ensure that the exhaust pipe outlet is not directed at any flammable or combustible surfaces.



- **Exhaust System Cleaning Indicator Lamp** - Illuminates when the exhaust system is unable to complete an automatic Exhaust System Cleaning event. Operator should ensure that the Exhaust System Cleaning Switch is not in the STOP position and continue working until there is an opportunity, such as at the end of the work day or shift to complete a stationary Exhaust System Cleaning.



- **Exhaust System Cleaning Indicator Lamp with Check Engine Indicator Lamp** - If an Exhaust System Cleaning is not performed in a timely manner after the Exhaust System Cleaning Indicator Lamp is illuminated, the Check Engine Indicator Lamp will illuminate and engine power will be significantly reduced. Park the machine when safe to do so and press the Exhaust System Cleaning Start Switch. Once cleaning is complete, full engine power will be restored.



- **Exhaust System Cleaning Indicator Lamp** - Flashes when a stationary Exhaust System Cleaning event is initiated using the Exhaust System Cleaning Start Switch. This lamp will continue to flash until the stationary cleaning event is complete. Once the lamp turns off, the operator can resume normal operation.



ON

- **Exhaust System Cleaning Stop Indicator Lamp** - Illuminates when the Exhaust System Cleaning Switch is in the STOP position, preventing a cleaning event. This switch should be used only when high exhaust temperatures present a hazard. Excessive use of the Exhaust System Cleaning Switch in the STOP position will result in the need for more frequent stationary exhaust cleaning events.



ON

- **Stop Engine Indicator Lamp (if equipped)** - Illuminates when continued operation could result in damage to the exhaust system. Shut down the engine as soon as it is safe to do so and call for service to avoid damage to the exhaust system.

To Perform an Exhaust System Cleaning

1. Park the machine in a safe location where the exhaust pipe outlet will not face any combustible surface.
2. Engage the parking brake.
3. With the engine running and at idle, press the Manual Regen Button (located on the Machine Display - Machine Diagnostics Page).

NOTE: When the cleaning event is activated, engine speed may increase and the HEST Indicator Lamp (located on the Machine Display) may illuminate and the Exhaust System Cleaning Indicator Lamp will flash.

4. Monitor the machine and surrounding area for safety.

NOTE: If the machine needs to be used or moved, stop the stationary cleaning event by increasing the Throttle Switch (located near the Hydrostatic Drive Control Handle).

5. When the Exhaust System Cleaning is complete, the engine will return to normal idle speed and the HEST and Exhaust System Cleaning Indicator Lamps will turn off.

Further Information

Refer to the *Maintenance and Storage Section* provided elsewhere in this manual for additional Aftertreatment service and maintenance information.

Refer to the engine manufacturer's operation manual for complete operating instructions and safety precautions.

HYDROSTATIC DRIVE

The Hydrostatic Drive System uses pressurized hydraulic fluid to drive the machine. The Hydrostatic Drive System consists of four components: Diesel Engine, Hydrostatic Pump, Wheel Motors, and Wheel Hubs.

Hydrostatic Drive Components

- John Deere Final Tier 4 PSS 9.0L Diesel Engine
- Hydrostatic Pump
- Wheel Motors (4)
- Wheel Hubs (4)

Engine and Hydrostatic Pump

Your machine is featured with a John Deere Final Tier 4 PSS 9.0L diesel engine (located beneath the rear hood). The engine has a direct-mounted Hydrostatic Pump (located near the center of machine).



John Deere Final Tier 4
PSS 9.0L Diesel Engine
-Typical View

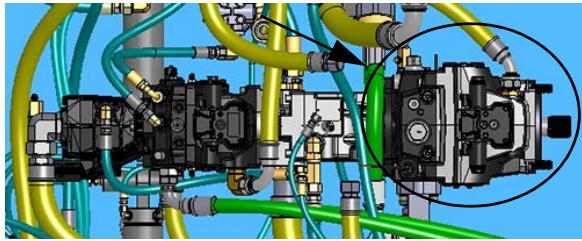

Hydrostatic Pump (Drive Pump)
-Typical View
(Viewed from top of machine)

Wheel Motors and Hubs

The drive system consists of hydraulic Wheel Motors and Gear Reduction Hubs (Wheel Hubs) located on each wheel.

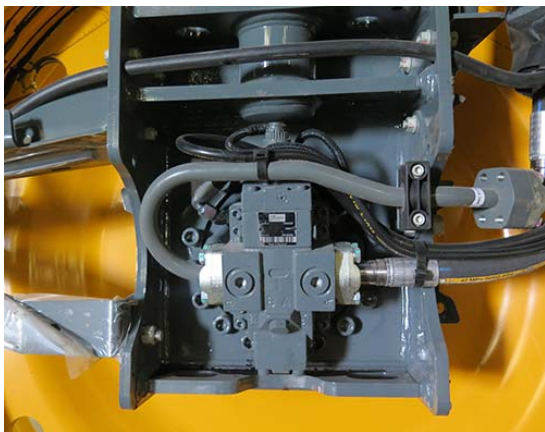

Wheel Motor
-Typical View

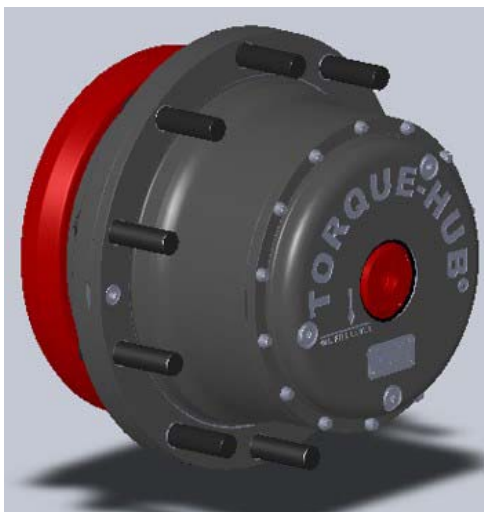

Wheel Hub
-Typical View

Parking Brake

The Parking Brake will engage when applied hydraulic pressure falls below 150 PSI (10.3 bar) or if the engine is shut off.

CAUTION

Do not engage the parking brake while the machine is moving. Failure to comply may result in personal injury and machine damage.

NOTICE

The parking brake is not intended for normal or emergency stopping.

NOTE: Bring the machine to a complete stop before engaging the Parking Brake.

The Parking Brake also controls the Ladder. When the Parking Brake is engaged, the Ladder will extend (lower). When the Parking Brake is disengaged, the Ladder will retract (raise).

CAUTION

Ensure the Hydrostatic Drive Control Handle is in the NEUTRAL position before engaging the parking brake. Failure to comply may result in personal injury and/or machine damage.

- **To engage the Parking Brake and lower the Ladder**, move the Hydrostatic Drive Control Handle to the NEUTRAL position.

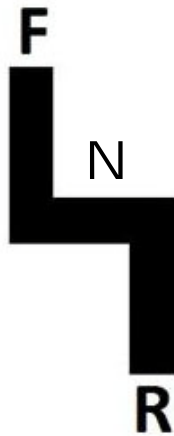

Hydrostatic Drive Control Handle
-Typical View

- Slide the red safety lever (located on the Parking Brake Switch) DOWN (Back) and press top of switch DOWN.



Parking Brake Switch
(Located near the Hydrostatic Drive Control Handle)
-Typical View

NOTE: When the Parking Brake is engaged, a parking brake indicator (located on the top left-hand side of each Machine Display page) and the Parking Brake Switch will illuminate.



Parking Brake Indicator
(Located on the top left-hand side of each Machine Display page)

To Disengage the Parking Brake

NOTICE

The Decel Pedal must be held in the DOWN position while disengaging the parking brake.

NOTE: If the Hydrostatic Drive Control Handle is out of neutral while the parking brake is engaged, the following warning message will appear on the Machine Display. Press OK to acknowledge.



Parking Brake Warning Message

- To disengage the Parking Brake and raise the Ladder, press and hold the Decel Pedal (located to the lower right-

hand side of the steering column) and press the Parking Brake Switch in the DOWN (Off) position.

Deceleration (Decel) Pedal

When nearing an end row and speed deceleration is desired, press the Decel Pedal (located on the lower right-hand side of the steering column) to decrease speed.

NOTE: The Decel Pedal is NOT a brake! It is designated for speed reduction only.



Decel Pedal
(Located on the lower right-hand side of the steering column)
-Typical View

Setting Decel Pedal Minimum Speed

Refer to “Machine Display” provided in the Cab Section elsewhere in this manual for further information.

Target Speed

The Target Speed (displayed on the Machine Display Home Page - Road and Field Mode) is the speed in which the machine travels when the Hydrostatic Drive Control Handle is in the fully FORWARD position and the Decel Pedal is NOT pressed.

NOTE: The Target Speed displayed is the maximum speed for the selected speed range.

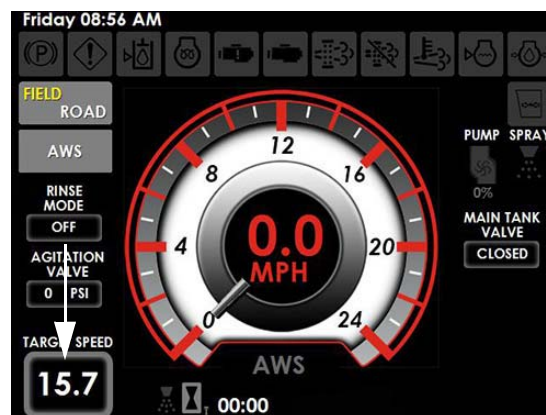

Target Speed
(Located on the Home Page - Road and Field Mode)

To Change Target Speed

Refer to “Machine Display” provided in the Cab Section elsewhere in this manual for further information.

Throttle Switch

The Throttle Switch (located near the Hydrostatic Drive Control Handle) is used to control engine speed (RPM).

NOTE: The operator may select throttle setting by operating the Throttle Switch. However, engine speed is also controlled by movement of the Hydrostatic Drive Control Handle.



Throttle Switch
(Located near the Hydrostatic Drive Control Handle)
-Typical View

NOTE: Engine speed can range between 850 and 2200 RPM in both Road and Field Mode.

The Throttle Switch works with a timer to tell the engine how fast to run. The longer the operator holds the switch in either direction (press UP/“rabbit icon” to increase the speed, press DOWN/“turtle icon” to decrease the speed), the more the engine will speed up or slow down.

To Change Throttle Setting Values

Refer to “Machine Display” provided in the *Cab Section* elsewhere in this manual for information.

Speed Ranges

Speed ranges are selected by pressing the Shift Up/Down Switches (located on the Hydrostatic Drive Control Handle). Refer to “Machine Display” provided in the *Cab Section* elsewhere in this manual for further information on adjusting speed range settings.

Example:

If speed ranges are set at 5, 10, 15, and 20 mph (8, 16, 24, and 32 km/h), the machine will start in the 5 mph (8 km/h) target range. Press the Shift Up Switch once to reach 10 mph (16 km/h). Continue to press switch to reach 15 and 20 mph (24 and 32 km/h), as desired. Press the Shift Down Switch gradually to decrease speed range.

NOTE: The Shift Up/Down Switches can also be held to increase or decrease speed ranges.



Shift Up/Down Switches
(Located on the side of the
Hydrostatic Drive Control Handle)
-Typical View

Drive System Control

⚠ WARNING

Ensure the back-up alarm is audible when operating the machine in reverse.

NOTE: The NEUTRAL position must be met before changing the direction of the machine.

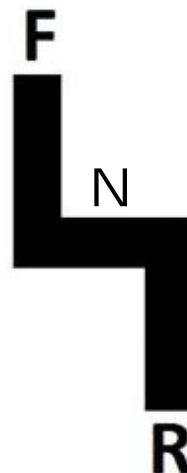

- **To move the machine forward**, slowly push the Hydrostatic Drive Control Handle FORWARD.

NOTE: The further the handle is moved forward, the faster the machine will travel and the engine speed will increase.

- **To move the machine in reverse**, slowly pull the Hydrostatic Drive Control Handle backward.

NOTE: Machine speed is limited to 9 mph (14.5 km/h) when in reverse.

NOTE: The farther back the handle is pulled, the faster the machine's speed.

- **To stop the machine**, slowly place the Hydrostatic Drive Control Handle in the NEUTRAL position.

NOTE: Before turning the engine off, reduce the engine speed and allow to idle for a minimum of three (3) minutes.

NOTE: Read the following AWS information thoroughly and understand the operating instructions and safety precautions before operating.



Hagie Manufacturing Company recommends becoming familiar with and understanding how to operate your machine in conventional steering mode before operating AWS. Understand AWS system components, operating procedures, and system limitations before operating.

The term “coordinated steering” is used to describe the AWS feature. Coordinated steering is when the front wheels turn one direction and the rear wheels turn in the opposite direction to create a tighter turn angle, which allow the rear wheels to follow the front wheel tracks. Operating your machine in AWS mode makes turning more efficient by minimizing crop damage and ground disturbance.

Ensure you are comfortable driving the machine on the road and in the field, with the booms in the transport and spray positions, as well as performing a variety of different turning scenarios before attempting to operate AWS.

| |
|--|
| <h2>NOTICE</h2> |
| <p>The operator can choose a minimum level above 850 RPMs of engine speed that they want to operate the machine with by using the Throttle Switch.</p> |

ALL-WHEEL STEER (AWS)

-If Equipped

^ Operator's with machines equipped with AWS pay special attention!

| |
|--|
| <h2>NOTICE</h2> |
| <p>Become familiar with the machine in both coordinated and conventional steering modes before attempting to use the machine for its intended use. ^</p> |

Progressive AWS

(Activated between 7-10 mph/11.3-16.1 km/h)

Hagie Manufacturing Company's Progressive AWS takes the original design and increases the active speed range while maintaining a safe turning radius. This is done by limiting how far the rear wheels will turn at higher speeds. The improvement allows operators to follow contours in the field and leave only one set of wheel tracks. This also allows them to make wide turns on end rows with only one set of wheel tracks.

Your rear wheels will track the front wheels, with limitations on speed and turning percentage. This is completely variable, so if you accelerate in a turn, your match on the rear will slowly come out. This feature keeps the machine safe when turning.

NOTE: If you want to match all the time, decrease your speed or make a less drastic turn.

NOTE: AWS is disabled when Auto Steer is active.

Terminology

Conventional Steering

- Only the front wheels turn.

Coordinated Steering ^

- All the wheels turn and do so where the rear tires follow in the front tires' tracks.



AWS Components

The Steering Cylinder (internal position) and External Proximity Sensors are used to track cylinder rod extension.

Steering Cylinder



Steering Cylinder
-Typical View

External Proximity Sensor



External Proximity Sensor
-Typical View

Lock Valves

Each rear cylinder is equipped with two (2) Lock Valves, which lock the cylinders into position when in Road Mode, and when the machine is not moving, in Field Mode.

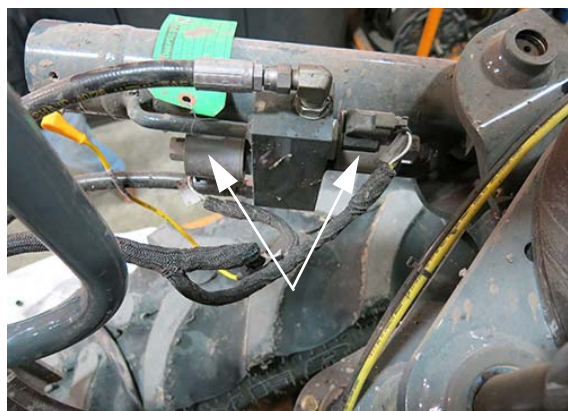

Lock Valves
-Typical View

Valve Manifold

Rear hydraulic steering is controlled by a Valve Manifold (located on the underside of the machine).



Valve Manifold
(Located on the underside of machine)
-Typical View

Operating AWS

All conditions must be met before AWS will activate. First, the machine must be in Field mode, and second, machine speed must be less than AWS Shutoff Speed. If these conditions are not met, the AWS Button will remain ON, but the AWS indicator will turn OFF, and the machine will be operating in conventional steering mode.

When conditions are met again, AWS will automatically activate and the AWS indicator will illuminate.

NOTE: The machine will automatically determine if the proper conditions have been met and change the status of the drive functions.

1. Ensure the machine's drive state is in Field mode.
2. Press the AWS Button (located on the Machine Display Home Page - Field Mode) to the ON (illuminated) position.

• AWS Button

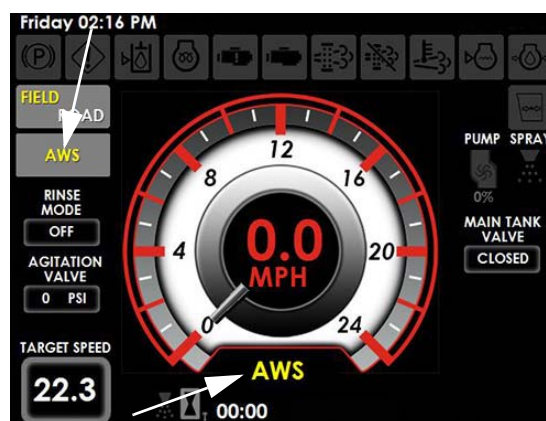

• AWS Indicator

An AWS indicator (located below the speedometer) will illuminate when AWS is activated (requiring all conditions to be met).

Shut off Speed for AWS

Refer to “Machine Display” provided in the Cab Section elsewhere in this manual for further information.

Limitations

- Machine speed is greater than AWS shut-off speed.

NOTE: There is no warning message associated with this. The machine will automatically switch to conventional steering mode.

- The machine's drive state must be in Field Mode. If the machine is in Road Mode, AWS is disabled (and the rear cylinder lock valves are locked).

- System Fault - The system is not working properly (e.g. sensor malfunction, hydraulic malfunction, etc.)

NOTE: A warning message will appear on the Machine Display and the machine may be limited on speed and other functions.

- **Auto Steer Machines Only:**
When the Auto Steer System is engaged, it will automatically turn the AWS System OFF and move the rear wheels back to straight.

Recommendations for Best Operating Practices

- Apply the Decel Pedal (located to the lower right-hand side of the steering column) to decrease speed at end rows.

NOTE: The Decel Pedal is NOT a brake! It is designated for speed reduction only.

- Speed ranges are selected by pressing the Shift Up/Down Switches (located on the Hydrostatic Drive Control Handle) to control speed ranges within the vehicle speed settings.
- Use the Hydrostatic Drive Control Handle to slow down more if needed. If you move the Hydrostatic Drive Control Handle first and then shift down to get to AWS mode, you will notice that the machine may slow down more than you wanted it to.
- Understand how the machine feels when it is still in a turn and is shifted up or down. The machine will still operate at whatever turn angle that you want to shift out at, but you may feel that this situation is causing an operation that you may not want (possibly getting the machine off the line intended because the rear wheels move back to straight position and the total turning radius will change).

In the following illustration, the two circles represent a full turn with AWS on. The - - - - lines represent the direction the operator wants the front tracks to go (assuming the operator wants to pull the machine back into

rows that are running straight up and down.) The - - - - lines represent the direction that the front wheels are pointed when the operator shifts out of AWS speed range. If this occurs, the rear wheels will shift back to the straight position and the machine will no longer have the two tire tracks (two circles). The rear wheels will begin to follow the - - - - path during this shift.

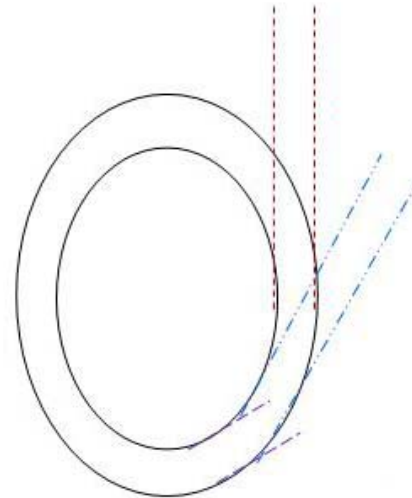

Hagie Manufacturing Company once again strongly recommends trying out and getting a feel for the AWS System before going straight to the field so you can get an understanding of what to expect. Some situations to try include:

- Driving the machine with both an empty and a full solution tank with AWS on.
- Drive the machine on hills, ensuring to take the proper precautions as stated in the *Safety and Precautions Section* elsewhere in this manual.
- Drive the machine at different turn angles and speeds to see how the limitations work.

NOTE: You will notice that if you go over any of the limitations, you can slow back down and the AWS system will automatically turn itself back on.

- **Auto Steer Machines Only:**
Notice how the machine feels when in AWS mode and switching from Auto Steer ON to OFF, especially when turning.



- Contact your local John Deere dealer with any questions you may have regarding the operation of the AWS System.

HYDRAULIC SYSTEM COMPONENTS



Hydraulic Pumps (Mounted to the engine)

- Pressure Compensated (PC) Pump
- Fan Pump
- Load Sense (LS) Pump
- Drive Pump

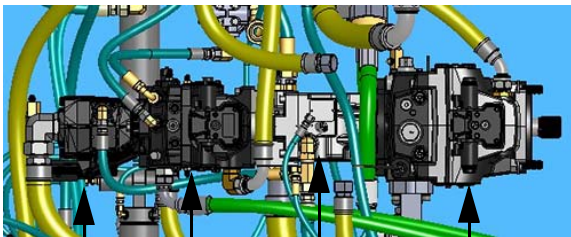

- PC Pump
- Fan Pump
- LS Pump
- Drive Pump

Hydraulic Pumps
(View shown from top of machine)

The four Hydraulic Pumps (mounted to the engine) circulate hydraulic oil throughout the necessary systems and back through the oil cooler before returning it to the reservoir.

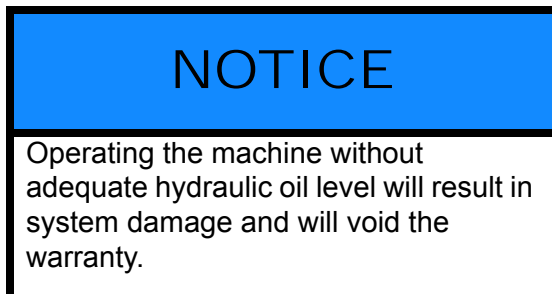

If hydraulic oil level is too low for safe operation, a warning message will appear on the Machine Display to alert you of low hydraulic oil level. Press OK to acknowledge, shut down the engine immediately, and refill reservoir to proper level to avoid damage to the hydraulic systems.

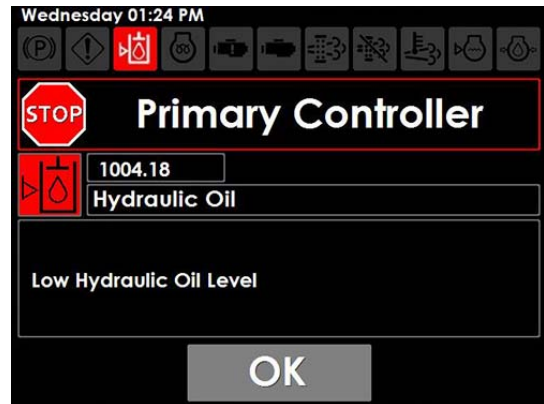

Low Hydraulic Oil Level Warning Message
(Located on the Machine Display)

PC Pump

The PC Pump powers the high-pressure filter, power steering, attachments, tread adjustment valve, side-fill valve, AWS valve (if equipped), and the pressure washer valve (if equipped).

Fan Pump

The Fan Pump powers the reversible fan motor.

LS Pump

The LS Pump powers the solution pump control valve.

Drive Pump

The Drive Pump powers the wheel motors.

Hydraulic Filtering/Cooling Components

- Oil Cooler
- Hydraulic Oil Reservoir
- Return Filter
- Pressure Filter
- Case Drain Filters (2)
- Breather Cap

SECTION 5 – HYDRAULIC SYSTEMS



- Level/Temp Sensor

NOTE: Refer to the Maintenance and Storage Section elsewhere in this manual for information on filling the hydraulic oil reservoir and replacing hydraulic filters.



Oil Cooler
(Located ahead of engine -
remove radiator screen to access)
-Typical View



Hydraulic Oil Reservoir
(Located on rear left-hand side
of machine - open hood to access)
-Typical View



Return Filter
(Located inside filter housing
on top of hydraulic oil reservoir)
-Typical View



Pressure Filter
(Located beneath right-hand side of
machine - lower metal shield to access)
-Typical View



Case Drain Filter 1
(Located on right-hand side
of machine near batteries)
-Typical View



Breather Cap
(Located on rear left-hand side of
machine behind air intake filter)
-Typical View

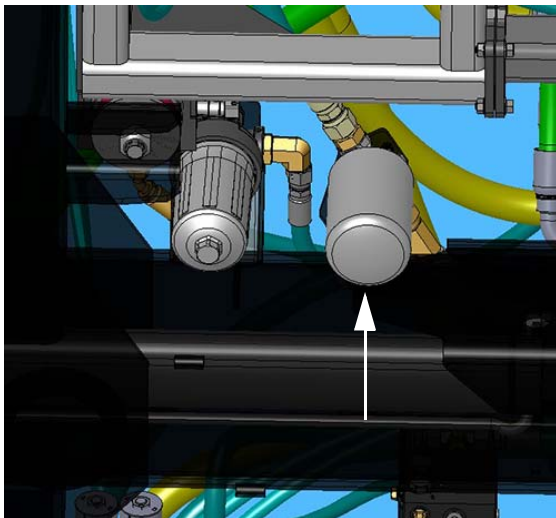

Case Drain Filter 2
(Located on left-hand side of
machine ahead of engine frame)
-Typical View



Level/Temp Sensor
(Located on top of hydraulic oil reservoir)
-Typical View

Hydraulic Spray System Components

- Solution Pump
- Solution Pump Control Manifold
- Boom Control Manifold
- NORAC® Boom Leveling System (if equipped)

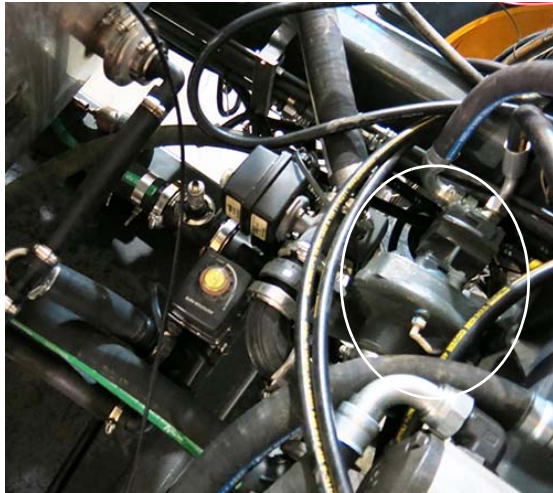

Solution Pump
(Located near center of machine)
-Typical View

* View shown from top of machine

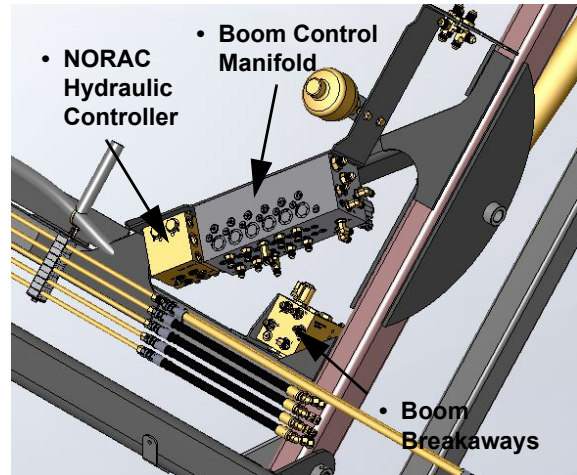

Boom Control Manifold and
NORAC Hydraulic Controller - *if equipped*
(Located on the boom lift arm assembly)
-Typical View

* 90-ft. Spray Boom Shown

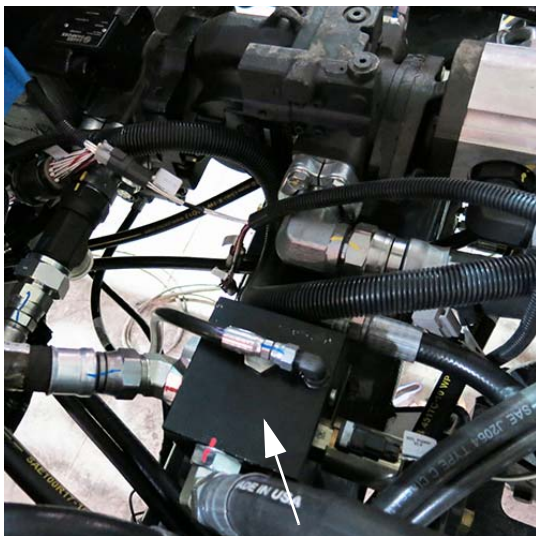

Solution Pump Control Manifold
(Located near center of machine)
-Typical View

* View shown from top of machine

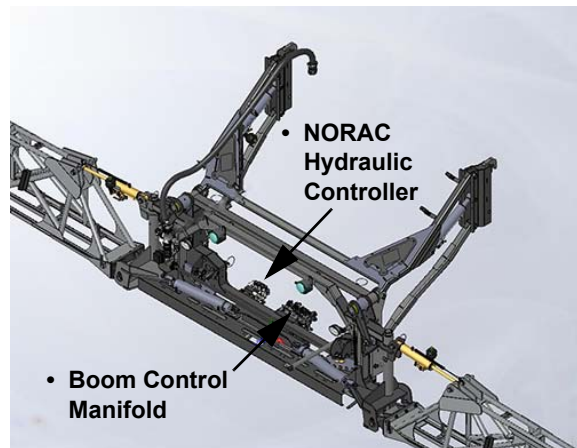

Boom Control Manifold and
NORAC Hydraulic Controller
(Located near center of inner transom)
-Typical View

* 120/132-ft. Spray Booms

Refer to the *Spray Systems Section* elsewhere in this manual for further information.

REVERSIBLE FAN

WARNING

Improper operation, maintenance, or repair of this product can be dangerous and may result in serious injury or death.

- Always use Hagie-approved parts and components. Failure to comply will result in voiding the 1-year parts warranty.
- Do not operate or perform any service on this product until you have read and understand the operation and maintenance information. Contact your local John Deere dealer for any additional information that you may require.
- The person(s) servicing the product may be unfamiliar with many of the systems or components of the product. Use caution when performing service. Knowledge of the product and components are important before the removal or disassembly of any component.

WARNING



**Avoid rotating fan.
Stop engine.
Keep clear to avoid
serious injury.**

T198283

The Reversible Fan is hydraulically driven via the constant pitch fan hydraulic motor, which in turn, is driven by the hydraulic pump. The system's hydraulic pump is driven directly off engine-supplied PTO (power take-off) to efficiently draw power independent of engine speed. An electrically-controlled proportional pressure control valve (FDC - Fan Drive Control mounted to

pump) modulates fan speed depending on machine's cooling demand. On-demand operator input controls the fan reversing option to provide the operator the ability to purge debris from the cooling package shroud.

NOTE: The fan system reduces power and fuel consumption of the engine when full airflow is not required to keep the engine cool.

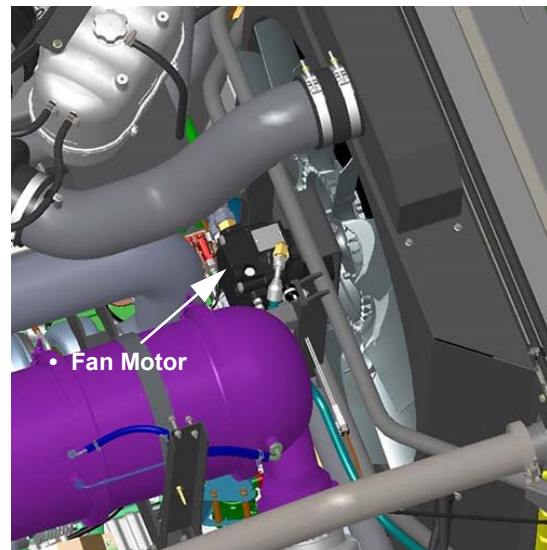

Reversible Fan
(Located near the rear of machine
- open hood to access)
-Typical View

To Activate the Reversible Fan

Refer to "Machine Display" provided in the *Cab Section* elsewhere in this manual for complete operating instructions.

Before Starting the Engine

1. Ensure all hoses and wires are adequately secured and routed away from the fan operating area.
2. Ensure all tools have been removed from the engine compartment, including the top side of the radiator and inside of the shroud before the fan guards are installed. Obstacles in the path of rotation can interfere with movement of the fan and can result in damage to the fan blades, fan hub, and radiator core.

3. Inspect the radiator shroud mounting bolts to ensure that the radiator and shroud are firmly secured and unable to move during operation of the machine. Loose shroud bolts can allow the fan shroud to move into the path of the rotating blades and loose radiator mounting bolts can allow the radiator to flex in position, allowing the shroud to come into contact with the rotating fan blades.
4. Ensure all fan guards have been installed and firmly secured into place. The Reversible Fan creates an abundant amount of airflow in both cooling and cleaning mode operation. The result of this airflow is a strong vacuum effect that can suck in items that are located inside or around the engine compartment fan.
5. To ensure maximum efficiency, start with a clean cooling system free of debris, paying particular attention to the stacked cooler core(s).

Service and Maintenance

 **WARNING**

Ensure the Battery Disconnect Switch is OFF before performing any service on the fan. Failure to comply may result in engine turnover, serious injury, or death.

Under normal operating conditions, the Reversible Fan does not require scheduled maintenance (other than lubrication) and is built to provide thousands of hours of trouble-free service.

In moderate to extreme operating conditions, a visual inspection of moving parts is recommended from time to time to safeguard against fan blade damage, which could lead to equipment and/or other damage.

TREAD ADJUSTMENT - HYDRAULIC

-If Equipped

NOTE: Contact your local John Deere dealer for assistance in adjusting manual tread width on your machine (if equipped).

Your machine may be equipped with Hydraulic Tread Adjust to boost capability and perform applications for various field row widths and cropping stages with minimal crop damage.

Tread Range

- Min. Tread Width = 120" (304.8 cm)*
- Max. Tread Width = 160" (406.4 cm)*

* Depending on tire size.

 **CAUTION**

Never adjust hydraulic tread width on a public roadway. Ensure the machine is on level ground where there are no ditches or valleys to interfere while you perform the adjustment.

NOTICE

Survey your surroundings and allow yourself enough room to adjust tread width in either forward or reverse.

NOTICE

The machine must be in motion while adjusting tread width. Failure to comply may result in machine damage.

NOTICE

The machine's drive state must be in FIELD MODE before adjusting tread width.

NOTICE

Tread Adjust is disabled when traveling at speeds above 10 mph (16 km/h).

Hydraulic Manual Tread Adjust

1. Engage the parking brake.
2. Start the engine.
3. Press the Field/Road Button (located on the Machine Display Home Page) and change the machine's drive state to FIELD.

NOTE: The drive state of the machine cannot be changed unless the Hydrostatic Drive Control Handle is in the NEUTRAL position (and machine speed is less than 0.5 mph/ 0.8 km/h).

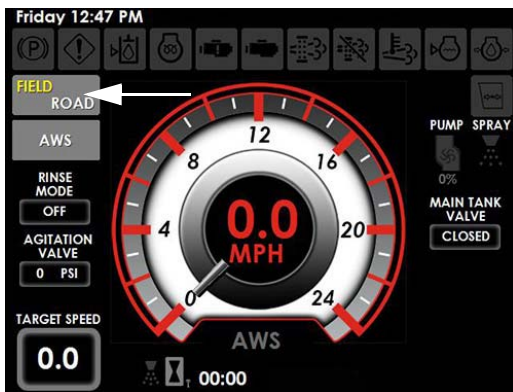

Field/Road Button
(Located on the Machine Display Home Page)

NOTE: The selected drive state will illuminate.

4. Press the Manual Button (located on the Machine Display Auxiliary Controls Page).

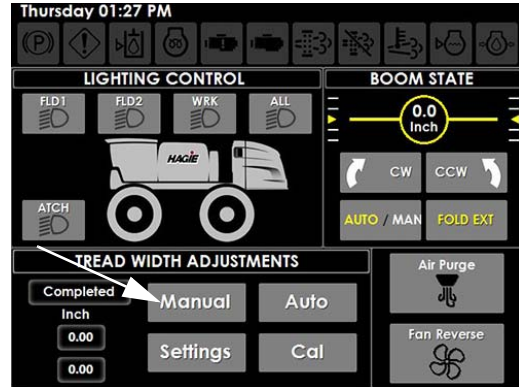

Manual Button
(Located on the Machine Display Auxiliary Controls Page)

5. On the Tread Adjustment Screen, select the tread that you wish to adjust by pressing the desired "wheel(s)" on the display screen.

NOTE: Tread width may be adjusted individually or simultaneously.

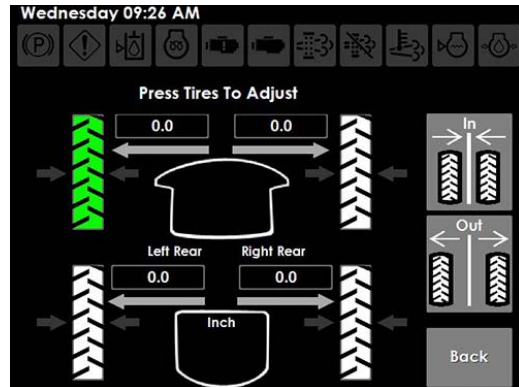

Tread Adjustment Screen

6. With the machine moving in forward or reverse - at speeds up to 10 mph (16 km/h), press and hold the In or Out Button until desired tread width is achieved.

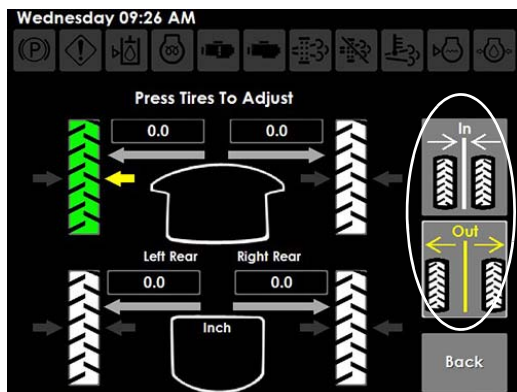

In/Out Buttons

7. Observe tread width - either by the tread decals (located on each leg), or the individual readings on the Tread Adjustment Screen.

In addition, front and rear tread width is also displayed on the Machine Display Auxiliary Controls Page, which gives the current measurement of the furthest out reading.



Tread Decal
(Located on each leg)
-Typical View



Front/Rear Tread Width Indicators
(Located on the Machine Display
Auxiliary Controls Page)

8. Release the In or Out Buttons when desired tread width is achieved.

Hydraulic Auto Tread Adjust

1. Engage the parking brake.
2. Start the engine.
3. Press the Field/Road Button (located on the Machine Display Home Page) and change the machine's drive state to FIELD.

NOTE: The drive state of the machine cannot be changed unless the Hydrostatic Drive Control Handle is in the NEUTRAL position (and machine speed is less than 0.5 mph/ 0.8 km/h).

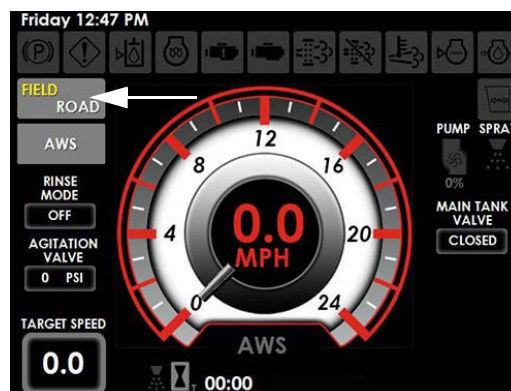

Field/Road Button
(Located on the Machine Display
Home Page)

NOTE: The selected drive state will illuminate.

- Press the Auto Button (located on the Machine Display Auxiliary Controls Page).

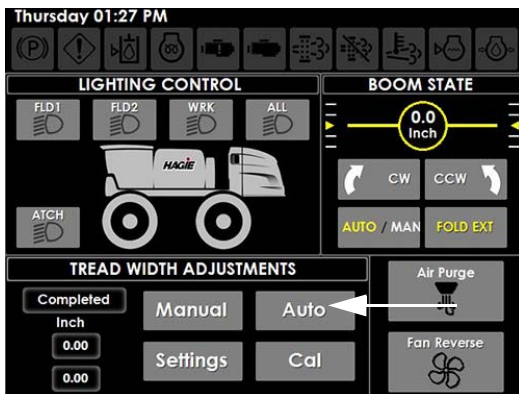

Auto Button
(Located on the Machine Display
Auxiliary Controls Page)

- On the Auto Screen, press EDIT (next to desired front or rear tread width setting).

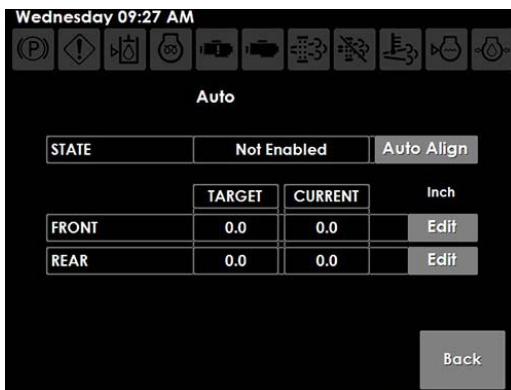

Auto Screen

- Enter new value (distance of extended cylinder), then press OK.

NOTE: Tread width values are based off of travel distance.

NOTE: Front and rear axles may be set separately if desired.

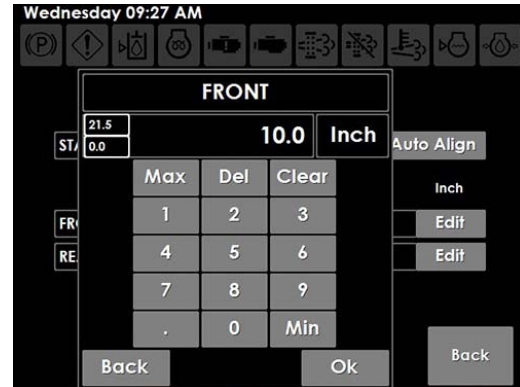

Input Screen
(Front tread shown)



Tread Adjust Sensor (4)
(Located on each leg)
-Typical View

- Press the Auto Align Button (located on the Auto Screen) to begin sensor alignment.

NOTE: The display will show "Pending" until machine speed is above 0 and less than 10 mph (16 km/h) and Field Mode is active. Once desired distance is achieved, the display will show "Completed" and tread valves will not activate.

Tread Calibration

Tread Calibration may be performed during initial setup, if a tread sensor has been replaced, or if tread is not traveling to desired programmed spacing.

NOTICE

Ensure the legs are fully retracted before calibrating.

1. Engage the parking brake.
2. Start the engine.
3. Ensure the machine’s drive state is in Field Mode.
4. Ensure all legs are in the fully retracted or narrowest position.
5. With the machine moving in forward or reverse - at speeds up to 10 mph (16 km/h), press the Calibration Button (located on the Machine Display Auxiliary Controls Page).

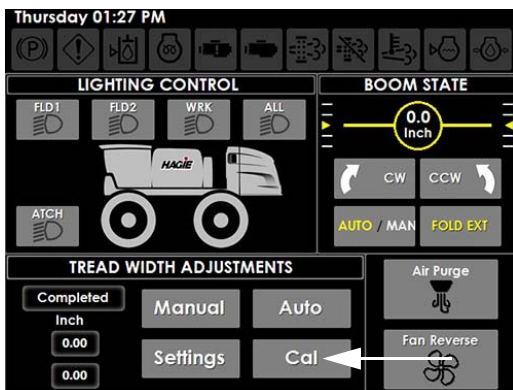

Calibration Button
(Located on the Machine Display Auxiliary Controls Page)

6. On the Calibration Screen, press CALIBRATE to begin calibration.

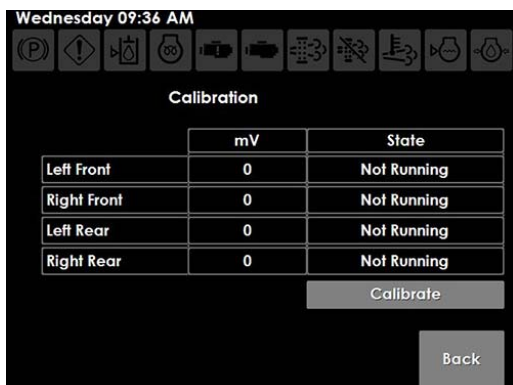

Calibration Screen

NOTE: As calibration cycles, the current state will appear on the Calibration Screen (i.e. “Not Running, “Moving Outward”, or “Completed”).

NOTE: During calibration, the front legs will move out first, followed by the rear legs.

LADDER

CAUTION

Upright ladder is not a service platform or step.

- DO NOT step on the ladder while in the upright position.
- DO NOT lower the ladder while anyone is on the ground near the machine.
- DO NOT attempt to lower the ladder from ground level.

Failure to comply may result in injury.

To Lower the Ladder

CAUTION

Ensure the Hydrostatic Drive Control Handle is in the NEUTRAL position before engaging the parking brake. Failure to comply may result in personal injury and/or machine damage.

- **To lower the Ladder**, move the Hydrostatic Drive Control Handle to the NEUTRAL position.

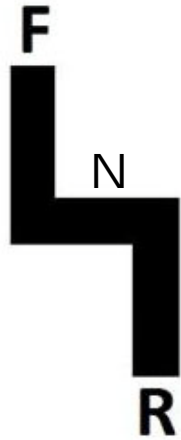

Hydrostatic Drive Control Handle
-Typical View

- Slide the red safety lever (located on the Parking Brake Switch) DOWN (Back) and press top of switch DOWN.



Parking Brake Switch
(Located near the Hydrostatic Drive Control Handle)
-Typical View

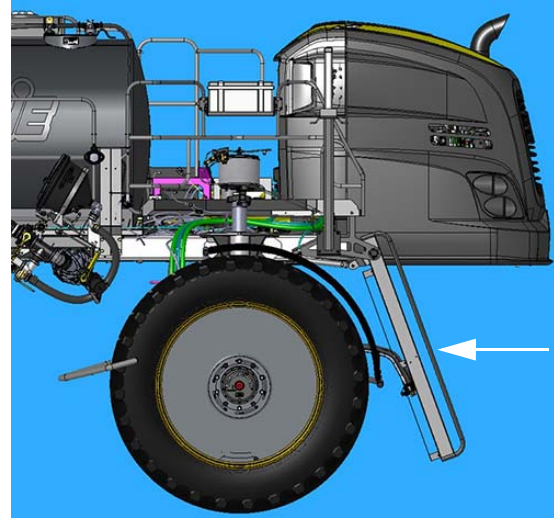

Ladder
(Located on the rear left-hand side of machine)
-Typical View
* Lowered position shown

NOTE: When the Parking Brake is engaged, a parking brake indicator (located on the top left-hand side of each Machine Display page) and the Parking Brake Switch will illuminate.

To Raise the Ladder

- **To raise the Ladder**, press and hold the Decel Pedal (located to the lower right-hand side of the steering column) and press the Parking Brake Switch in the DOWN (Off) position.

NOTE: When the Ladder is raised, the Parking Brake will be OFF (disengaged).

PRESSURE WASHER

-If Equipped

NOTE: The Parking Brake must be engaged before operating the Pressure Washer.

⚠ CAUTION

Pressurized water can be abrasive.

- Never point the spray wand at persons or any part of the human body.
- Never directly spray fragile or sensitive materials.

Failure to comply may result in personal injury or property damage.

⚠ CAUTION

Never tie open the spray wand trigger or start the machine with the spray wand unattended. High-pressure flow may cause the spray wand to become a projectile hazard, resulting in personal injury or property damage.

⚠ CAUTION

Wear goggles or a face shield to protect eyes from spray, chemicals, or back-spattered material while operating the pressure washer.

NOTICE

Never use the pressure washer to spray items under the hood. Failure to comply may result in engine and other component damage and will void the warranty.

NOTICE

Never run the pressure washer without water supply. Operating without water will cause pump failure and will void the warranty.

NOTE: Inspect the pressure washer hose daily for cuts or abrasions.

To Operate the Pressure Washer

1. Ensure there is adequate amount of water in the rinse tank.
2. Ensure the Pressure Washer wand and hose are securely connected.

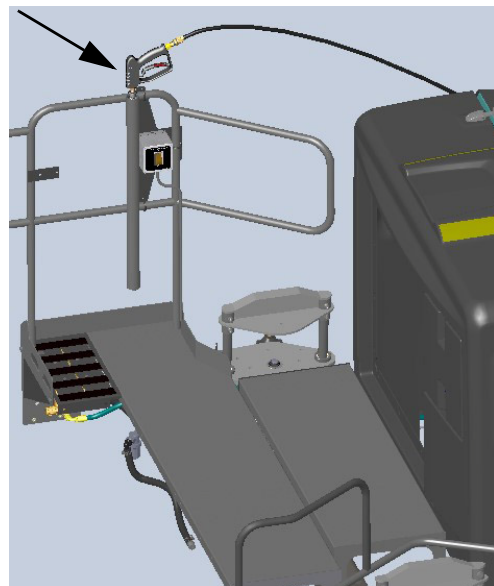

Pressure Washer Wand
(Mounted on the rear right-hand handrail)
-Typical View

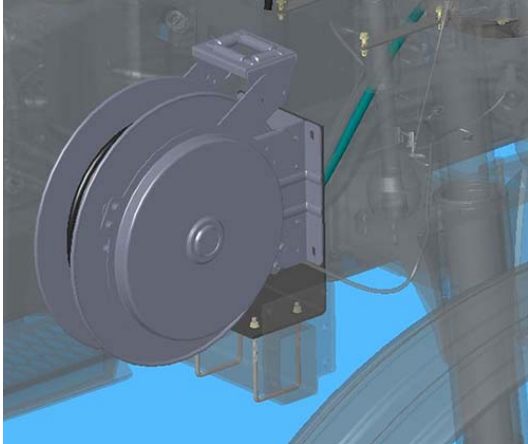

Pressure Washer Hose Reel
(Located near the rear
right-hand side of machine)
-Typical View

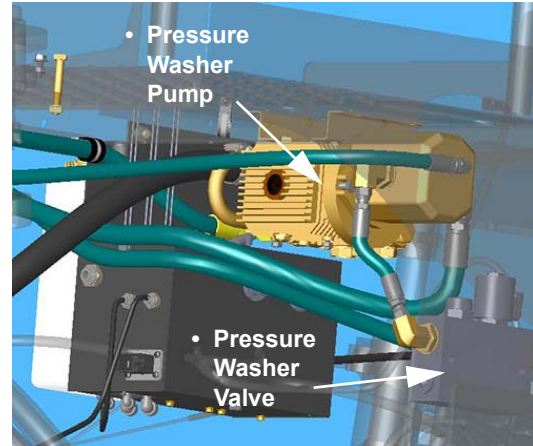

Pressure Washer Pump/Valve
(Located beneath platform on
rear right-hand side of machine)
-Typical View

3. Engage the parking brake.
4. Start the engine.
5. Activate the Pressure Washer Pump (located beneath platform on the rear right-hand side of machine) by pressing the Pressure Washer Switch (mounted on the rear right-hand handrail) in the UP (On) position.

6. The Pressure Washer is now ready for use. Extend hose as desired.
7. **When finished**, retract hose and press the Pressure Washer Switch in the DOWN (Off) position.

Pump Maintenance

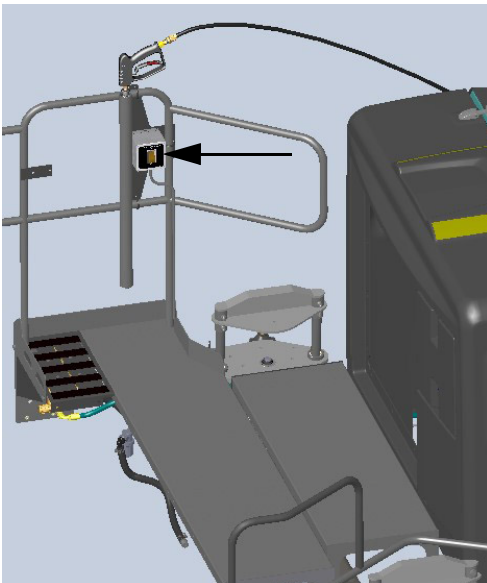

Pressure Washer Switch
(Mounted on the rear right-hand handrail)
-Typical View

NOTICE

Do not run acids, petroleum-based solvents, highly chlorinated materials, or insecticides through the pressure washer pump. Failure to comply may result in internal component damage. Use only detergents formulated for use with pressure washers and follow the manufacturer's instructions for use.

- Check pressure washer pump oil level daily. "Top off" as required.
- Change the pressure washer pump oil every 200 hours of operation.
- 30-weight non-detergent oil recommended.



Further Information

Refer to the manufacturer's information for safety precautions, maintenance and storage information, and troubleshooting tips.

SECTION 6 – ELECTRICAL SYSTEMS

WARNING

CALIFORNIA PROPOSITION 65 WARNING

WARNING: Diesel engine exhaust and some of its constituents are known to the State of California to cause cancer and birth defects or other reproductive harm.

WARNING: Battery posts, terminals, and related accessories contain lead and lead compounds, and chemicals known to the State of California to cause cancer and birth defects or other reproductive harm.

NOTICE

Use a sturdy stationary ladder to safely access/service the batteries.

Access

The batteries are located in the engine compartment on the rear right-hand side of machine (open hood to access).

NOTE: When servicing the electrical system, always remove the batteries (removing the ground cable first). When reinstalling the batteries, connect the ground cable last.

BATTERIES

CAUTION

Batteries contain sulfuric acid. Avoid contact with skin, eyes, or clothing. Do not inhale fumes or ingest liquid. Batteries contain gases which can explode. Keep sparks and flame away while servicing.

CAUTION

Disconnect the battery when servicing any part of the electrical system. Failure to comply may result in injury and property damage.

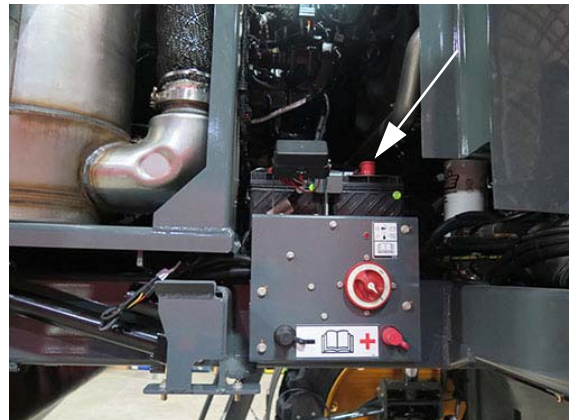

Battery Access
(Located inside engine compartment
on rear right-hand side of machine
- open hood to access)
-Typical View

Charging

CAUTION

Electrical system is 12-volt negative ground. When using booster with jumper cables, precautions must be taken to prevent personal injury or damage to electrical parts.

1. Attach one end of jumper cable to positive booster terminal and other end to positive terminal of vehicle battery connected to starter motor.
2. Attach one end of second cable to negative booster terminal and other end to vehicle frame away from battery.
3. To remove cables, reverse above sequence exactly to avoid sparks. See operator's manual for additional information.

For your convenience, a set of Auxiliary Battery Charging Posts are located in the engine compartment on rear right-hand side of machine (open hood to access) for ease of charging the batteries.

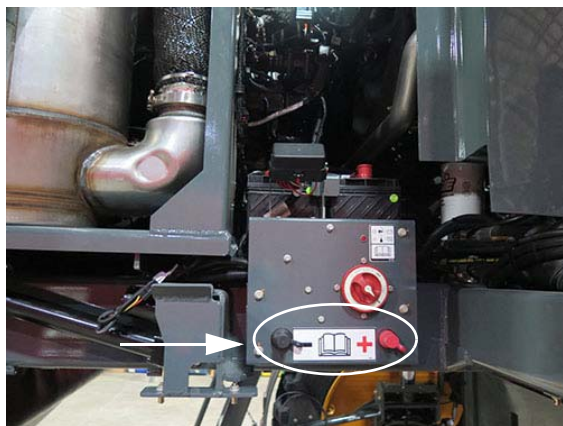

Auxiliary Battery Charging Posts
(Located inside engine compartment
on rear right-hand side of machine
- open hood to access)
-Typical View

Connect your charging cables to the Auxiliary Battery Charging Posts just as you would to the battery - positive cable to the positive terminal, and negative cable to the negative terminal.

NOTE: Keep these terminals clean and their caps in place when not in use.

NOTICE

To ensure sufficient electrical contact, battery terminal connections should be as clean and tight as possible.

Cleaning

- Disconnect the battery cables from the batteries.
- Remove any corrosion with a wire brush or battery post brush.
- Wash the battery cable connections and posts with a mild baking soda and ammonia solution.
- Apply grease (or dielectric grease) to prevent corrosion.
- Reconnect the batteries, ensuring connections are tight.
- Clean every 100 hours of operation.

Replacement

Install replacement batteries with ratings equivalent to the following specifications:

- **Voltage** - 12V only
- **CCA** - 30 seconds at 0° F. (950)
- **Reserve Capacity** - 185 minutes at 25 amps

Storage

Refer to "Storage" provided in the *Maintenance and Storage Section* elsewhere in this manual for further information.

BATTERY DISCONNECT SWITCH

WARNING

DO NOT use the Battery Disconnect Switch as a safety device when performing work to the electrical system. Disconnect the negative battery cable before servicing.

IMPORTANT

- Do not bypass disconnect.
- Do not terminate electrical devices to battery terminals.
- Turn switch off before servicing electrical equipment.
- Completely isolate electronics before welding by disconnecting battery negative terminal.
- Rotate switch to “ON” position for operation.

Your machine is equipped with a Battery Disconnect Switch (located in the engine compartment on rear right-hand side of machine - open hood to access) to de-energize battery power, cutting all electrical power to the engine.

- Rotate the Battery Disconnect Switch to the ON (clockwise) or OFF (counter-clockwise) positions to operate.

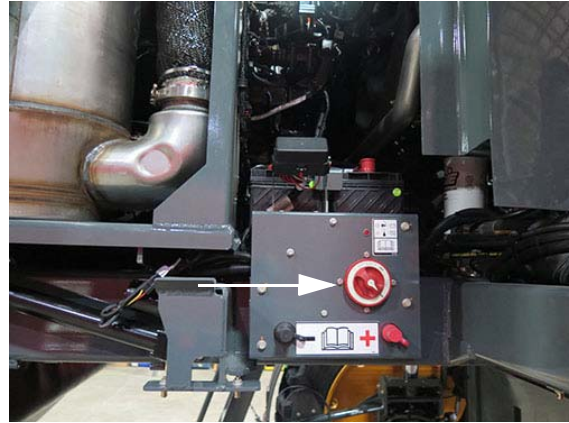

Battery Disconnect Switch
(Located inside engine compartment
on rear right-hand side of machine
- open hood to access)
-Typical View

NOTE: Turn the Battery Disconnect Switch OFF during long storage periods.

Final Tier 4 Engine

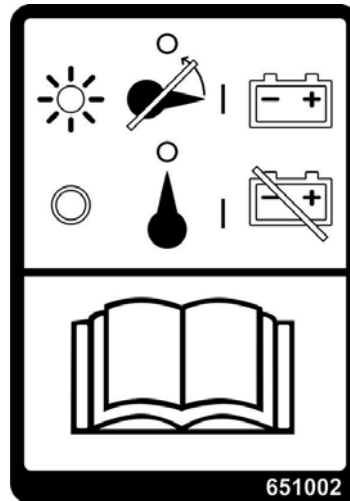

DO NOT TURN BATTERY DISCONNECT SWITCH OFF WHEN FINAL TIER 4 INDICATOR LIGHT IS ILLUMINATED

NOTICE

Allow the Diesel Exhaust Fluid (DEF) Recirculation Pump to finish running before turning the Battery Disconnect Switch off. Failure to comply may result in aftertreatment system component damage.

After the ignition key is shut off, the Final Tier 4 Engine Indicator Light (located near the Battery Disconnect Switch) will flash until it is safe to shut off the battery disconnect. This will allow the DEF Recirculation Pump to purge the system and the engine ECM to shut down.

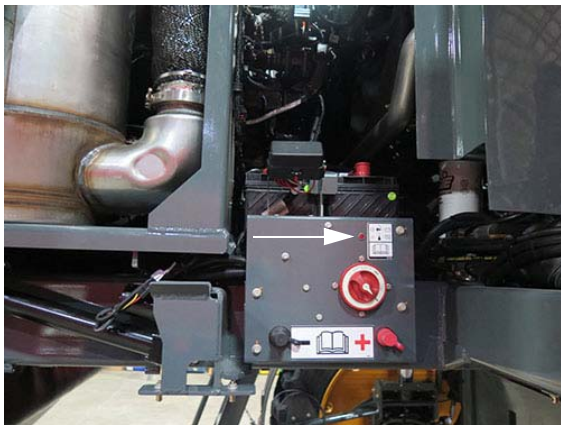

Final Tier 4 Engine Indicator Light
(Located near the
Battery Disconnect Switch)
-Typical View

If you wish to trickle charge the batteries, an extension cord must be brought to the machine and plugged into the Battery Tender's 120-volt AC plug (standard electrical plug). The Battery Tender can be plugged in indefinitely as it monitors battery charge and prevents itself from overcharging the batteries.

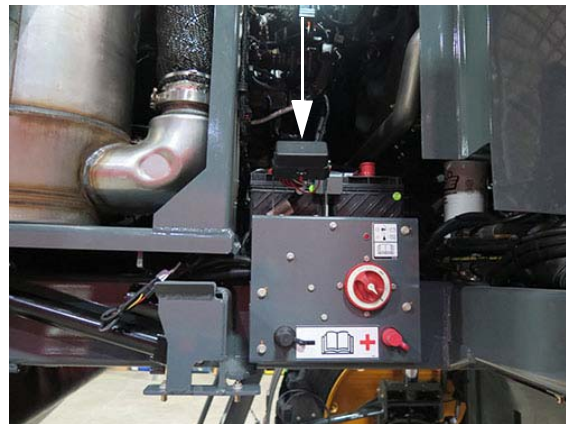

Battery Tender
(Located inside engine compartment
on rear right-hand side of machine
- open hood to access)
-Typical View

BATTERY TENDER

-If Equipped

Your machine may be equipped with a Battery Tender (located inside the engine compartment on the rear right-hand side of machine - open hood to access) to maintain battery charge during extended storage periods. The Battery Tender is factory-installed and comes already connected to the batteries.

FUSES AND RELAYS

Interior Cab Functions



Circuit Breakers/Fuses (Interior)
(Located rear of side console -
remove tray to access)
-Typical View

The following label is affixed beneath the side console (remove tray to access) and provides information on component fuse/relay amperage ratings.

| | |
|---|--|
| <p>Mini-Fuses</p> <ul style="list-style-type: none"> F01 - HVAC Power (25A) F02 - A-Post Gauges (5A) F03 - Spray Section Keypad (5A) F04 - Radio (10A) F05 - Wiper/Washer (15A) F06 - Aux Sw Pwr 1 (15A) F07 - Pod Sw Pwr (5A) F08 - Sw Pwr Signal (3A) F09 - Chassis XA2-0 Pwr (20A) F10 - Steering Column/Bat Pwr (20A) F11 - Rotating Beacons (15A) F12 - Attach Vlv Pwr 2 (20A) | <p>Mini-Fuses</p> <ul style="list-style-type: none"> F26 - EDP Bat Power (5A) F27 - Ignition Key (10A) F28 - Steering Column Pwr (15A) F29 - Pod Bat Pwr (10A) F30 - Power Outlets (20A) F31 - Power Con 1 & 2 Bat Pwr (20A) F32 - Power Con 2 Sw Pwr (20A) F33 - Aux Sw Pwr 2 (15A) F34 - Seat Power (20A) F35 - Aux Sw Pwr 3 (20A) F36 - Pwr Con 1 Sw Pwr (20A) F37 - SASA Kick-out (15A) |
| <p>F13 - Chassis XA2-1 Pwr (20A)</p> <p>F14 - Attach Vlv Pwr 1 (20A)</p> <p>F15 - Attach Vlv Pwr 3 (20A)</p> <p>F16 - Attach Mod Pwr 1 (20A)</p> <p>F17 - Attach Mod Pwr 2 (20A)</p> <p>F18 - Chas S-XA2-0 Pwr (20A)</p> <p>F19 - Attach Mod Pwr 3 (20A)</p> <p>F20 - Attach Mod Pwr 4 (20A)</p> <p>F21 - Field Lights 1 (15A)</p> <p>F22 - Aux Relay 1 (10A)</p> <p>F23 - Field Lights 2 (15A)</p> <p>F24 - Start Relay (10A)</p> <p>F25 - Radio/Dome Bat Pwr (5A)</p>  | <p>F38 - PRI-Con Mod Pwr (20A)</p> <p>F39 - SEC-Con Mod Pwr (20A)</p> <p>F40 - HVAC Clutch (15A)</p> <p>Relays</p> <ul style="list-style-type: none"> CR01 - Rotating Beacon Lights CR02 - Wiper CR03 - Wiper/Washer CR04 - Wiper Lights 1 CR05 - Field Lights 2 CR06 - Start Relay CR07 - Aux Relay 1 CR08 - SASA Kick-out <p>292629 32281-0 (LR-0)</p> |

Exterior Lights/System Functions



Circuit Breakers/Fuses (Exterior)
(Located beneath cab -
remove panel to access)
-Typical View

The following label is affixed beneath the cab and provides information on component fuse/relay amperage ratings.

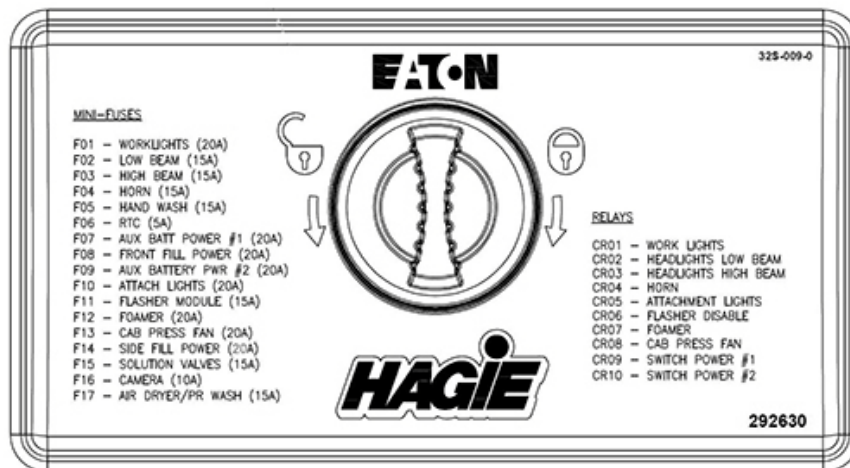

Solution Pump Relays



Solution Pump Relay Box
(Located beneath front end
of cab - lower panel to access)
-Typical View

The following relays are located within the solution pump relay box listed from top down.

| Function | Description/Rating |
|----------------------------|-------------------------------|
| Solution Pump Stop Relay | 12V SPST Relay - 35 Amp |
| Solution Pump Signal Relay | 12V SPDT Micro Relay - 35 Amp |
| Solution Pump Return Relay | 12V SPDT Micro Relay - 35 Amp |

Final Tier 4 Engine Fuses and Relays

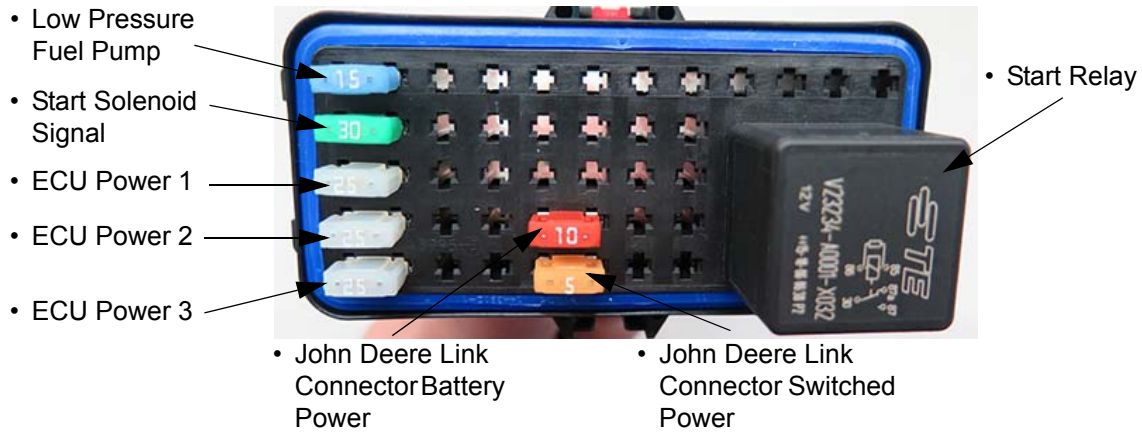

Fuses (Mini ATM LED): 5, 10, 15, 25, 30 respective amperage rating.

Start Relay: 12V/50A SPST mini relay.

Final Tier 4 Engine Fuse/Relay Block
(Located beneath batteries on
rear right-hand side of machine)
-Typical View

| Spare Devices (Located inside fuse/relay block cover - fuses only) | | |
|--|-----------|----------|
| Qty. | Device | Amperage |
| 1 | Mini Fuse | 30 |
| 2 | Mini Fuse | 25 |
| 1 | Mini Fuse | 15 |
| 1 | Mini Fuse | 5 |
| 1 | Mini Fuse | 10 |

Hood Actuator Fuse

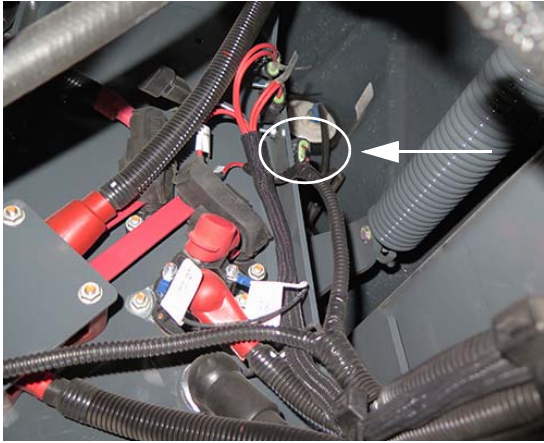

Hood Actuator Fuse
(Located beneath rear
left-hand side of machine)
-Typical View

FUSE AND RELAY RATINGS

| Fuses and Relays - Exterior (Located beneath cab) <i>- Remove panel to access</i> | | |
|---|----------------|----------------------------|
| Fuse | Rating (Amps) | Function |
| F01 | 20 | Work Lights |
| F02 | 15 | Highway Lights (Low Beam) |
| F03 | 15 | Highway Lights (High Beam) |
| F04 | 15 | Horn |
| F05 | 15 | Hand Wash |
| F06 | 5 | RTC Battery Power |
| F07 | 20 | Auxiliary Battery Power 1 |
| F08 | 20 | Front-Fill |
| F09 | 20 | Auxiliary Battery Power 2 |
| F10 | 20 | Attachment Lights |
| F11 | 15 | Flasher Module |
| F12 | 20 | Foam Marker |
| F13 | 20 | Cab Pressure Fan |
| F14 | 20 | Side-Fill |
| F15 | 15 | Solution Valves |
| F16 | 10 | Camera |
| F17 | 15 | Air Dryer |
| Relay | Ratings (Amps) | Function |
| CR01 | 35 | Work Lights |
| CR02 | 35 | Headlights (Low Beam) |
| CR03 | 35 | Headlights (High Beam) |
| CR04 | 35 | Horn |
| CR05 | 35 | Attachment Lights |
| CR06 | 35 | Flasher Disable |
| CR07 | 35 | Foam Marker |
| CR08 | 35 | Cab Pressure Fan |
| CR09 | 35 | Switch Power 1 |



| CR10 | 35 | Switch Power 2 |
|---|----------------------|---|
| Fuses and Relays - Interior (Located rear of side console) <i>- Remove tray to access</i> | | |
| Fuse | Rating (Amps) | Function |
| F01 | 25 | HVAC Power |
| F02 | 5 | A-Post Gauges |
| F03 | 5 | Boom Solution Valves (Spray Section Keypad) |
| F04 | 10 | Radio Power |
| F05 | 15 | Wiper/Washer Power |
| F06 | 15 | Auxiliary Switched Power 1 |
| F07 | 5 | Pod Switched Power |
| F08 | 3 | Power Mirrors/Power Signal for Auxiliary Switched Power (beneath cab) |
| F09 | 20 | Chassis XA2-0 Power |
| F10 | 20 | Steering Column/Battery Power |
| F11 | 15 | Rotating Beacons |
| F12 | 20 | Attachment Valve Power 2 |
| F13 | 20 | Chassis XA2-1 Power |
| F14 | 20 | Attachment Valve Power 1 |
| F15 | 20 | Attachment Valve Power 3 |
| F16 | 20 | Attachment Module 1 Power |
| F17 | 20 | Attachment Module 2 Power |
| F18 | 20 | Chassis S-XA2-0 Power |
| F19 | 20 | Attachment Module 3 Power |
| F20 | 20 | Attachment Module 4 Power |
| F21 | 15 | Field Lights 1 |
| F22 | 10 | Auxiliary Relay 1 |
| F23 | 15 | Field Lights 2 |
| F24 | 10 | Start Relay |
| F25 | 5 | Radio/Dome Light |
| F26 | 5 | EDP Battery Power |
| F27 | 10 | Ignition Key |
| F28 | 15 | Steering Column Power |

SECTION 6 -
ELECTRICAL SYSTEMS



| | | |
|---|----------------------|--|
| F29 | 10 | Pod Battery Power |
| F30 | 20 | Power Outlets |
| F31 | 20 | Power Connector 1 and 2 Battery Power |
| F32 | 20 | Power Connector 2/Switched Power |
| F33 | 15 | Auxiliary Switch Power 2 |
| F34 | 20 | Seat Power |
| F35 | 20 | Auxiliary Switch Power 3 |
| F36 | 20 | Power Connector 1/Switched Power |
| F37 | 15 | SASA Kick-out Signal |
| F38 | 20 | Primary Controller Power (beneath cab) |
| F39 | 20 | Secondary Controller Power (beneath cab) |
| F40 | 15 | HVAC Clutch |
| Relay | Rating (Amps) | Function |
| CR01 | 35 | Rotating Beacon Lights |
| CR02 | 35 | Wiper |
| CR03 | 35 | Wiper/Washer |
| CR04 | 35 | Field Lights 1 |
| CR05 | 20 | Field Lights 2 |
| CR06 | 20 | Start Relay |
| CR07 | 35 | Auxiliary Relay 1 |
| CR08 | 20 | SASA Kick-out Relay |
| Relays - External Harness (Located beneath right-hand side of cab) | | |
| | Rating (Amps) | Function |
| | 30A/50A | Solution Pump Signal |
| | 30A/50A | Solution Pump Return |
| | 30A/50A | Solution Pump Enable |
| Fuses and Relays - Final Tier 4 Engine (Located on engine skid near batteries) | | |
| Fuse (Mini) | Rating (Amps) | Function |
| F01 | 15 | Low Pressure Fuel Pump |

| | | |
|--------------|----------------------|--|
| F02 | 30 | Start Solenoid Signal |
| F03 | 25 | ECU Power 1 |
| F04 | 25 | ECU Power 2 |
| F05 | 25 | ECU Power 3 |
| F06 | 10 | John Deere Link Connector Battery Power |
| F07 | 5 | John Deere Link Connector Switched Power |
| Relay | Rating (Amps) | Function |
| CR01 | 12V/50A | Start Relay (SPST Mini Relay) |

VIDEO CAMERA INPUT CONNECTIONS

Your machine is equipped with a Video Camera (operated through the Machine Display) for your convenience when operating the machine in reverse and is located on the rear of the sprayer.

Two additional Video Camera Input Connections (located beneath cab - remove front panel to access) are provided for the installation of add-on video camera(s).

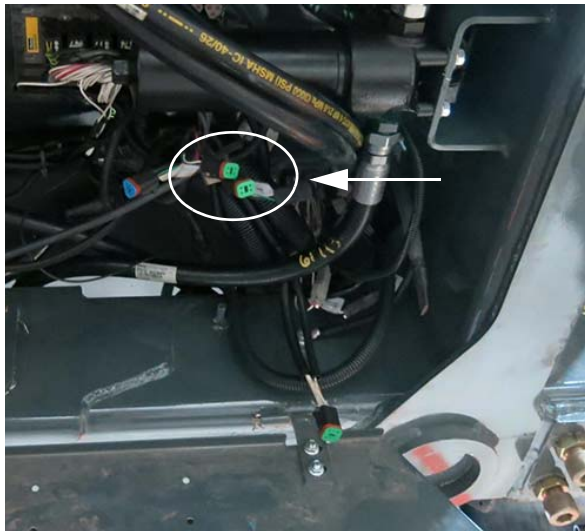

Video Camera Input Connections
(Located beneath cab -
remove front panel to access)
-Typical View

Refer to “Machine Display” provided in the *Cab Section* elsewhere in this manual for further information.

SPRAY BOOM HOSE RING INSTALLATION

(120/132' Spray Booms)

Four (4) Boom Hose Rings have been shipped loose with your machine and are located inside the cab. Refer to the following instructions to install rings before operating the spray booms.

NOTICE

Boom hose rings must be installed initially before unfolding the spray booms. Failure to comply will result in the solution hoses becoming obstructed with the boom, causing property damage.

To Install Boom Hose Rings

1. Engage the parking brake.
2. Start the engine.
3. Press and hold the corresponding Left and Right-Hand Boom Switches (located on the Hydrostatic Drive Control Handle) in the UP position to remove boom wings from cradles.



Left and Right-Hand Boom Switches
(Located on the Hydrostatic Drive Control Handle)
-Typical View

NOTICE

Unfold booms far enough to clear the boom cradles only. Unfolding the booms to the fully extended position before installing the boom hose rings will result in property damage.

4. Press and hold the corresponding Left and Right-Hand Boom Switches in the OUT position to unfold the boom wings until **partially** open.
5. Press and hold the Transom Switch (located on the Hydrostatic Drive Control Handle) in the DOWN position and lower boom to the ground.
6. Shut the engine off.
7. Obtain the four (4) Boom Hose Rings (located inside cab).
8. Loosen nuts on each Boom Hose Ring and remove bolts. Set aside for later use.
9. Rotate the Hose Routing Bracket (located near the end of the outer boom fold) so the wide end of bracket is facing outward (towards hose), as shown.

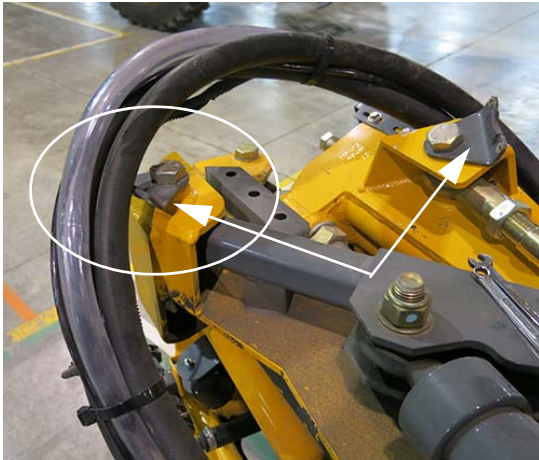

Hose Routing Brackets (2)
 (Located near the end of outer boom fold)
 -Typical View

10. Install Boom Hose Ring over top of the hose routing.



Boom Hose Ring
 -Typical View

11. Aligning Boom Hose Ring hole with the Hose Routing Bracket hole, install bolt (previously removed in Step 8) through the ring and bracket. Install second bolt to ring.
12. Hand-start nut on each bolt (as shown in the following photo). Tighten nut with a 7/16" wrench and bolt with a 3/8" wrench.



-Typical View

13. Following Steps 9-12, install second Boom Hose Ring to additional Hose Routing Bracket (as shown in the following photo).



Boom Hose Clamp Installation
 -Typical View

14. Repeat Steps 9-13 on opposite boom.

SPRAY BOOMS - 90/100'

-If Equipped

The spray booms are controlled by an electro-hydraulic system. This system consists of operator-manipulated switches (located on the side console and the hydrostatic drive control handle) and hydraulic cylinders (attached to the booms), which provide lift, level, horizontal extension, and vertical extension.

⚠ DANGER

To avoid injury or death do not contact electric lines when moving or operating this machine.

N204628

⚠ CAUTION

When operating or positioning the booms, observe the following safety precautions. Failure to comply may result in injury or equipment damage.

- Do not unfold/fold boom extensions when main boom is in cradle.
- Do not operate machine with one boom wing out of cradle and the other boom wing in cradle.
- Ensure booms are folded and in cradle before transporting the machine.

⚠ WARNING

Avoid serious injury from contact with hydraulic oil and gas under pressure. Before removing hydraulic components, disassembling or changing accumulators:

1. Relieve system hydraulic pressures. Refer to Operator Manual and Repair Manual for system information.
2. Stop engine and remove key. Use only DRY NITROGEN for recharging accumulator. See your John Deere dealer.

H0E2354

⚠ WARNING

When operating or positioning the booms, observe the following safety precautions:

- Monitor both sides of the boom during fold procedure.
- Cradle booms when leaving the machine unattended.
- Ensure booms are folded when cradled.
- Select a safe area before unfolding/folding the booms.
- Clear area of personnel.
- Check for overhead obstructions.
- Do not unfold/fold booms near power lines. Contact with power lines can result in serious injury or death.
- Spray equipment is designed for FIELD USE ONLY. Do not attempt to use machinery for anything other than it's intended purpose.

⚠ WARNING

Crush Hazard
Outer fold extension movement may occur while hydraulic system charges. Stay clear of hazard area. Fully extend or retract fold point before performing maintenance. Failure to comply may result in serious injury or death.

650204

⚠ CAUTION

Unexpected movement can cause serious injury or death
Objects directly below sensors will cause the boom wing to move. Disengage NORAC system before approaching sensors.

650210

WARNING

Hydraulic and electrical control systems are optimized for use of the spray boom attachment. Any modification to these systems may lead to unintended and uncontrolled motion. **DO NOT** install add-on control systems that are not approved by Hagie Manufacturing Company.

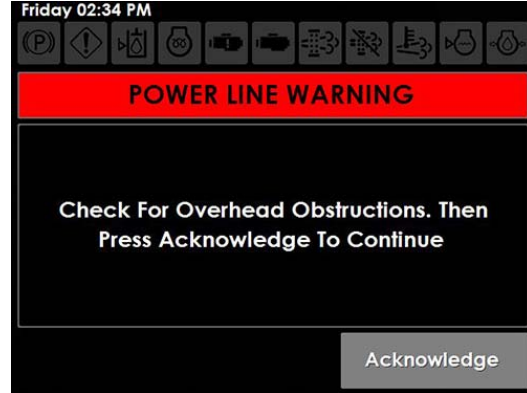

Power Line Warning Message
(Located on the Machine Display)

Power Lines

Hagie Manufacturing Company cannot stress enough that extreme caution must be taken when operating equipment near power lines. Ensure there is more than sufficient clearance when transporting, unfolding and folding the boom, or spraying near power lines.



As a safety precaution, a Power Line Warning Message will appear on the Machine Display before extending the outer boom extensions. Press **ACKNOWLEDGE** showing that you have acknowledged that there are no overhead power lines or obstructions before proceeding.

Hydraulically folding the extensions of a 60/80/90-ft. or 60/100-ft. spray boom, adjusting the spray valves, and shutting off the outer sections essentially turns it into a 60-ft. spray boom.

Manually folding the outer extensions of a 60/80/90-ft. spray boom, adjusting the spray valves, and shutting off the outer sections turns it into an 80-ft. spray boom (see the following illustrations).

Refer to the Spray System Console calibration information provided elsewhere in this section for further information.

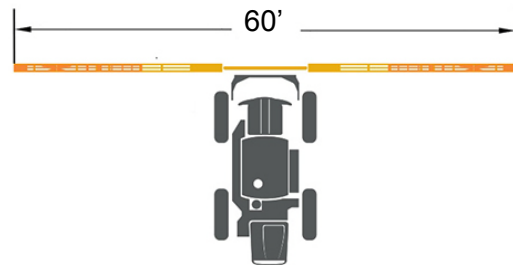

60/80/90' System with
Extensions Folded Over

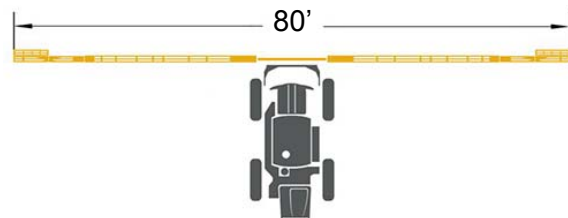

60/80/90' System with Outer
Extensions Manually Folded Forward

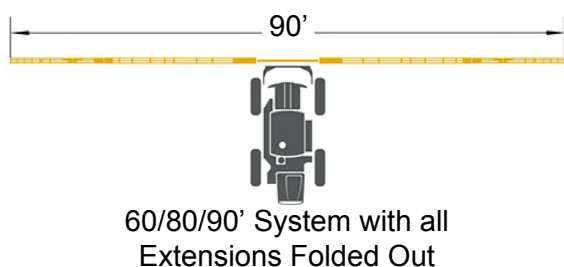

Spray Boom Components

- (A) - Lift Cylinder
- (B) - Transom
- (C) - Main Pivot Cylinder
- (D) - Level Cylinder
- (E) - Lift Arm
- (F) - Main Boom Section
- (G) - Boom Extension Cylinder
- (H) - Boom Extension (Outer Fold)
- (I) - Boom Breakaway Cylinder



Hydraulic Breakaway Circuit

90 and 100-ft. spray booms are equipped with a Hydraulic Breakaway Circuit. When folded out as an 80, 90, or 100-ft. spray boom, a one-way hydraulic circuit (located on the outer boom section) provides outer boom breakaway functions.



Outer Boom Breakaway
-Typical View

When the outer boom section breaks away, it will return to the “spray” position (after it has cleared the hazard), but will not be in the locked position.

To Reset the Outer Boom Breakaway:

- Press and hold the Reset Breakaways Button (Located on the Machine Display Auxiliary Controls Page) until the outer boom sections are in the LOCKED position.

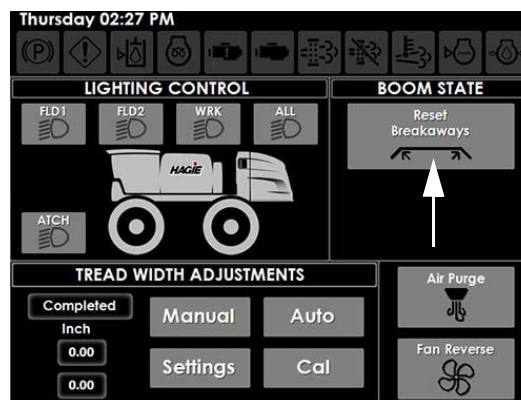

Reset Breakaways Button
(Located on the Machine Display
Auxiliary Controls Page)

NOTE: On 90-ft. spray booms, the main breakaways cannot be folded unless machine speed is less than 5 mph (8 km/h).

Boom Fold Procedure

CAUTION

Booms will unfold vertically even if they are still in the boom cradle or are not horizontally extended.

NOTICE

Do not move the transom up or down during boom fold procedure. Failure to comply may result in severe damage to the boom wing structures.

NOTICE

Do not lower the main lift while the boom is in cradle. Failure to comply will result in property damage.

Unfolding/Extending the Boom

NOTE: Ensure the Hydrostatic Drive Control Handle is in the NEUTRAL position. If the machine is put in gear during fold operation, boom movement will stop.

1. Press and hold the corresponding Left and Right-Hand Boom Switches (located on the Hydrostatic Drive Control Handle) in the UP position to raise the level cylinders all the way up.



Left and Right-Hand Boom Switches
(Located on the Hydrostatic Drive Control Handle)
-Typical View

2. Press and hold the corresponding Left and Right-Hand Boom Switches in the OUT position to unfold the main boom sections until they come to a complete stop.
3. Lower the level cylinders until the boom is parallel with the ground.

90-ft. Spray Booms

- Press and hold the Boom Extension Switch (located on the side console) in the UP position to unfold the left and right boom extensions all the way OUT.

NOTE: Both left and right boom extensions move simultaneously when the Boom Extension Switch is pressed.



Boom Extension Switch
* 90-ft. Spray Booms
(Located on the side console)
-Typical View



Boom Extension Switch
* 90-ft. Spray Booms
(Located on the side console)
-Typical View

Folding/Retracting the Boom

NOTE: Ensure the Hydrostatic Drive Control Handle is in the NEUTRAL position. If the machine is put in gear during fold operation, boom movement will stop.

1. Lower the level cylinders until the boom is parallel with the ground.

90-ft. Spray Booms

- Press and hold the Boom Extension Switch (located on the side console) in the DOWN position to fold the left and right boom extensions all the way IN.

NOTE: Both left and right boom extensions move simultaneously when the Boom Extension Switch is pressed.

2. Press and hold the corresponding Left and Right-Hand Boom Switches (located on the Hydrostatic Drive Control Handle) in the UP position to raise the level cylinders all the way up.



Left and Right-Hand Boom Switches
(Located on the Hydrostatic Drive Control Handle)
-Typical View

3. Press and hold the corresponding Left and Right-Hand Boom Switches in the IN position until the main boom sections are aligned with boom cradles.
4. Lower the level cylinders until the boom sections are seated in the boom cradles.

Manual Fold

(90-ft. Spray Boom to an 80-ft. Spray Boom)

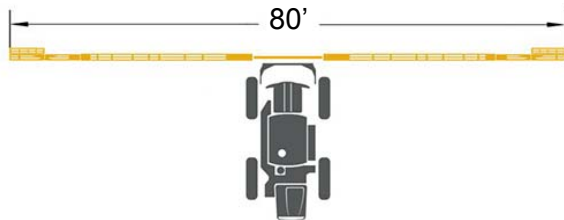

60/80/90' System with Outer Extensions Manually Folded Forward

1. Press Boom Solution Valve Switches - Sections 1 and 9 (located on the side console) to the OFF position.



Boom Solution Valve Switches - Sections 1 and 9 (Located on the side console) -Typical View

2. Remove the Securement Bolt (located on the back side of boom) and hinge outer section forward.



Securement Bolt (Located on the back side of boom) -Typical View



3. Secure into place with the rear Securement Bolt.
4. Repeat Steps 2-3 on opposite side of machine.

Enabling/Disabling NORAC® in the Pulse Display

-If Equipped

NOTE: Hagie Manufacturing Company recommends turning the NORAC Monitor OFF when traveling from one field to the next. A power switch is located on the back side of the monitor.



NORAC Monitor -Typical View

- **To Enable**, press the corresponding Auto or Manual Button (located on the main “Run Screen”) to the ON (green illuminated position).

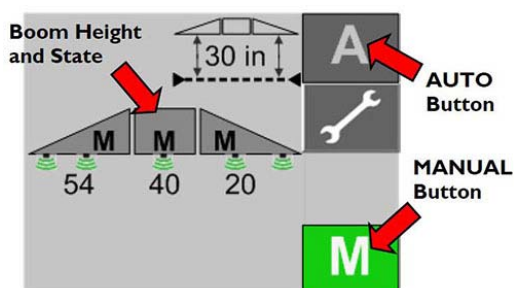

Auto/Manual Buttons - NORAC
(Located on the main “Run Screen”)
-Typical View

** Your monitor may vary in appearance, depending on model*

- **To Disable**, press the corresponding Auto or Manual Button to the OFF (gray) position or press any one of the following boom control switches (located on the Hydrostatic Drive Control Handle):
 - Transom Switch (Up/Down)
 - Left or Right-Hand Boom Switch (Up/Down)

NOTE: If the NORAC System becomes inoperable, the Auto and Manual Fold functions will still operate.

Enabling/Disabling NORAC in the Ag Leader® Display

-If Equipped

- **To Enable**, press the Auto/Manual Button (located on the main “Run Screen”) to the ON (green illuminated position).

NOTE: When the system is engaged, the boom image will change from black to blue.

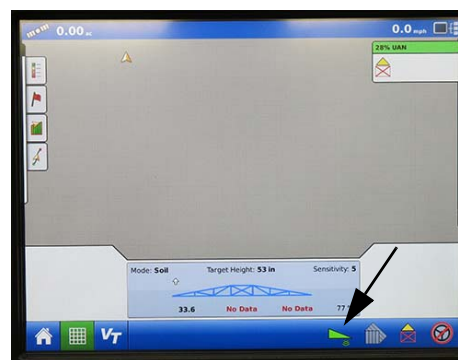

Auto/Manual Button - Ag Leader
(Located on the main “Run Screen”)
-Typical View

** Your monitor may vary in appearance, depending on model*

- **To Disable**, press the Auto/Manual Button to the OFF (white) position or press any one of the following boom control switches (located on the Hydrostatic Drive Control Handle):
 - Transom Switch (Up/Down)
 - Left or Right-Hand Boom Switch (Up/Down)

NOTE: When the system is disabled, the boom image will change from blue to black.

NOTE: If the NORAC System becomes inoperable, the Auto and Manual Fold functions will still operate.

NORAC/Ag Leader System Settings

-If Equipped
(Soil/Crop Mode, Target Height, and Sensitivity)

NOTE: Settings may be adjusted through the main Run Screen by pressing the Boom Image or the Settings Button (wrench icon), depending on model. Refer to the NORAC or Ag Leader manufacturer’s operation manual for further information.

Soil/Crop Mode

Soil Mode allows the sensors to read the height from the spray nozzles to the ground. Crop Mode allows the sensors to read the height from the spray nozzles to the top of the crop canopy.

On the NORAC Pulse Monitor:

- Press the Settings Button (wrench icon) (located on the main “Run Screen”) to navigate to the Settings Screen.
- Press the Next Button (located next to “Mode”) and select Soil, Crop, or Hybrid Mode.

NOTE: Hybrid Mode is an improved Crop Mode, which uses a combination of the crop and soil readings to improve control. This setting is recommended in place of Crop Mode.

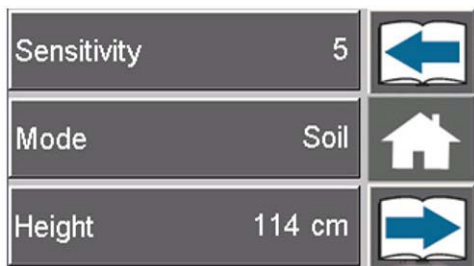

Settings Screen
(NORAC)
-Typical View

** Your monitor may vary in appearance, depending on model*

On the Ag Leader Monitor:

- Press the Boom Image (located on the main “Run Screen”).
- Press the top drop-down arrow (located on the Boom Height Control Options Screen) and select Soil or Crop Mode.

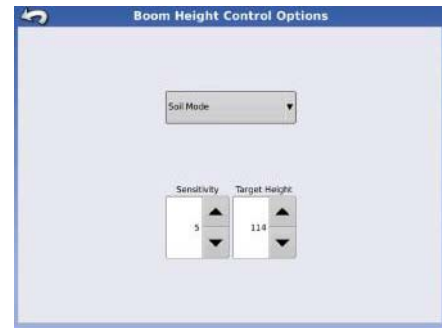

Boom Height Control Options Screen
(Ag Leader)
-Typical View

** Your monitor may vary in appearance, depending on model*

Sensitivity

Sensitivity is how responsive the system is. The lower the number, the lower the sensitivity. The higher the number, the higher the response time and hydraulic demand.

NOTE: Default sensitivity setting is 5.

On the NORAC Pulse Monitor:

- Press the Settings Button (wrench icon) (located on the main “Run Screen”) to navigate to the Settings Screen.
- Press the Next Button (located next to “Sensitivity”) and increase or decrease system sensitivity values from 1-10.

On the Ag Leader Monitor:

- Press the Boom Image (located on the main “Run Screen”).
- Press the Sensitivity Buttons (located on the Boom Height Control Options Screen) and increase or decrease system sensitivity values from 1-10.

Target Height

Target Height is the height you desire the boom to be set at when spraying.

NOTE: When operating in Soil Mode, the Target Height is measured from the spray nozzles to the soil. In Crop Mode, the target height is measured from the crop canopy to the spray nozzles.

On the NORAC Pulse Monitor:

- Press the Settings Button (wrench icon) (located on the main “Run Screen”) to navigate to the Settings Screen.
- Press the Next Button (located next to “Height”) and increase or decrease values to desired boom height.

On the Ag Leader Monitor:

- Press the Boom Image (located on the main “Run Screen”).
- Press the Target Height Buttons (located on the Boom Height Control Options Screen) and increase or decrease values to desired boom height.

Further Information

Refer to the NORAC or Ag Leader manufacturer’s operation manual for complete operating/calibration instructions, troubleshooting information, and safety precautions.

Refer to “Specifications” provided in the *Introduction Section* elsewhere in this manual for information on GPS dimensions on your machine.

Enabling NORAC through the End Row Management Switch

-If Equipped
(Typical View - appearance may vary, depending on model)

1. Program the End Row Management Switch (located on the Hydrostatic Drive Control Handle) through the Machine Display.
Refer to “Machine Display” provided in Section 3 - Cab elsewhere in this manual for initial setup instructions.



End Row Management Switch
(Located on the Hydrostatic Drive Control Handle)
-Typical View

2. On the NORAC or Ag Leader main “Run Screen”, press the “wrench” icon.

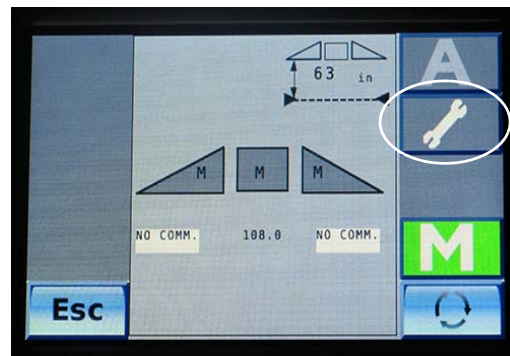

Main Run Screen
-Typical View

3. On the Settings Screen (1/3), press the “right/forward” blue arrow icon to navigate to the next screen.

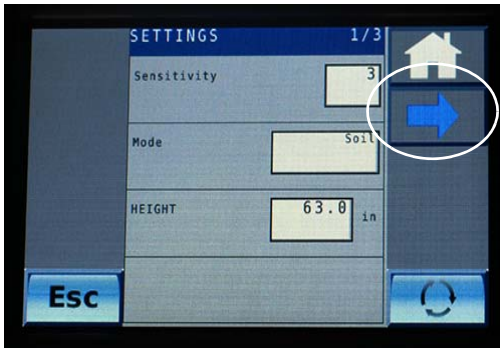

Settings Screen (1/3)
-Typical View

4. On the Settings Screen (2/3), press the “right/forward” blue arrow icon to navigate to the next screen.
5. On the Settings Screen (3/3), press the “check page” icon.



Settings Screen (3/3)
-Typical View

6. On the Options Screen (1/5), ensure the “Remote Switches” option is selected and press the “right/forward” blue arrow icon to navigate to the next screen.

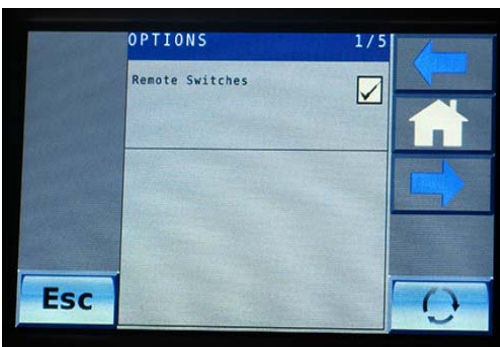

Options Screen (1/5)
-Typical View

7. On the Options Screen (2/5), select “Headland Assist”.

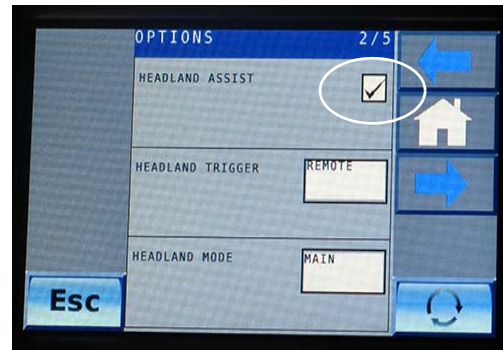

Options Screen (2/5)
-Typical View

8. On the Options Screen (2/5), press the selection area (next to “Headland Trigger”) and select REMOTE to enable NORAC through the End Row Management Switch.

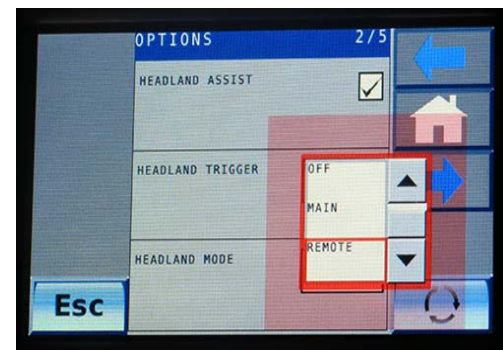

Options Screen (2/5)
-Typical View

9. On the Options Screen (2/5), press the selection area (next to “Headland Mode”) and select MAIN or WINGS.

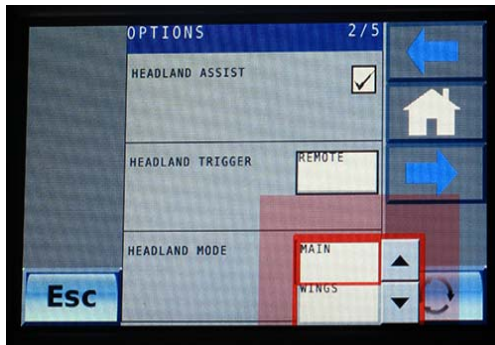

Options Screen (2/5)
-Typical View



SPRAY BOOMS - 120/132'

-If Equipped

The spray booms are controlled by an electro-hydraulic system. This system consists of operator-manipulated switches (located on the side console and the hydrostatic drive control handle) and hydraulic cylinders (attached to the booms), which provide lift, level, and horizontal extension.

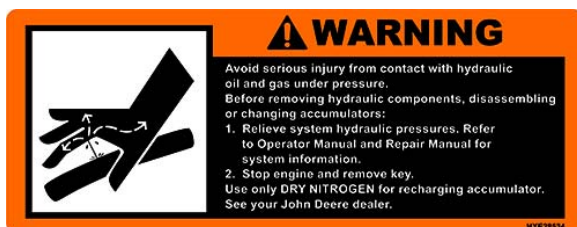
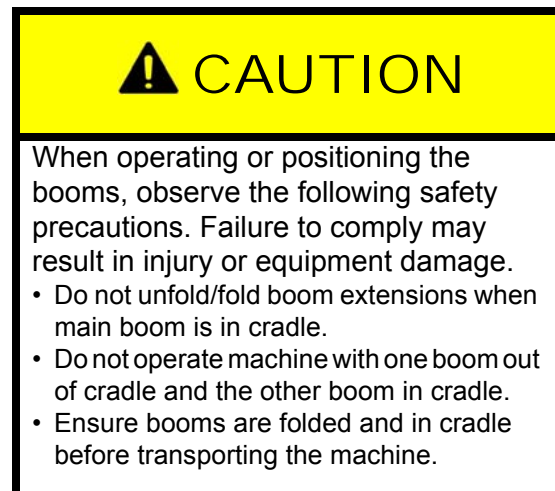

! WARNING

When operating or positioning the booms, observe the following safety precautions:

- Monitor both sides of the boom during fold procedure.
- Cradle booms when leaving the machine unattended.
- Ensure booms are folded when cradled.
- Select a safe area before unfolding/folding the booms.
- Clear area of personnel.
- Check for overhead obstructions.
- Do not unfold/fold booms near power lines. Contact with power lines can result in serious injury or death.
- Spray equipment is designed for FIELD USE ONLY. Do not attempt to use machinery for anything other than it's intended purpose.

! WARNING

Hydraulic and electrical control systems are optimized for use of the spray boom attachment. Any modification to these systems may lead to unintended and uncontrolled motion. DO NOT install add-on control systems that are not approved by Hagie Manufacturing Company.

Power Lines

Hagie Manufacturing Company cannot stress enough that extreme caution must be taken when operating equipment near power lines. Ensure there is more than sufficient clearance when transporting, unfolding and folding the boom, or spraying near power lines.



As a safety precaution, a Power Line Warning Message will appear on the Machine Display before extending the outer boom extensions or when operating in Auto Fold. Press ACKNOWLEDGE showing that you have acknowledged that there are no overhead power lines or obstructions before proceeding.



Power Line Warning Message
(Located on the Machine Display)

Hydraulically folding the extensions of a 120-ft. spray boom and shutting off the outer section valves (Boom Solution Valve Switches 1, 2, 8, and 9) essentially turns it into a 70-ft. boom (see the following illustrations).

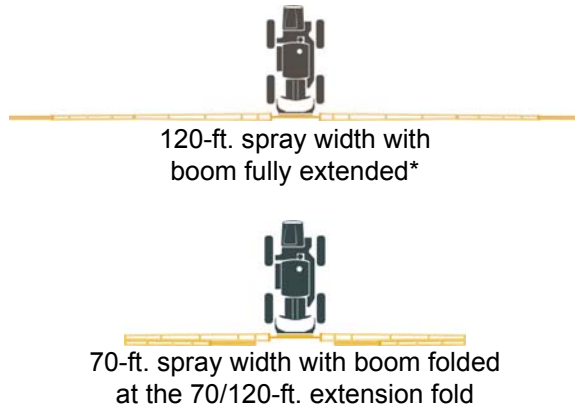

* *Recommended spray width*

Spray Boom Components

- Pivot Transom
- Fixed Transom
- Level Cylinders
- Roll Cylinder
- Proximity Sensors
- NORAC® Sensors
- Position Sensors
- Accumulators
- Main Pivot/Breakaway Cylinders
- Outer Breakaway (Tip)

Pivot Transom

The Pivot Transom houses work lights, solution valves, main fold cylinders, and solution plumbing.



Pivot Transom
-Typical View

Fixed Transom

The Fixed Transom and Lift Arm house the lift cylinders, pressure gauge, roll lock cylinders, boom stands, fold control manifold,

Hagie-installed modules, NORAC center sensor, and the NORAC lift/level hydraulic manifold.



Fixed Transom
-Typical View

Level Cylinders

The Level Cylinders (located on the left and right-hand side of the transom) are responsible for the up and down movement of the boom wings when the level controls are activated.



Level Cylinder
-Typical View

Roll Cylinder

The Roll Cylinders extend and retract, which provide the “roll” functions to aid in re-centering the boom for transport.

The Roll Cylinders are automatically placed into a “passive roll state” when the main booms are in the UNFOLDED position. This means the booms will be free to move

on the pendulum assembly at this point. The hydraulic valves and cylinders will not stop this from occurring.



Roll Cylinder
-Typical View

Proximity Sensors

External Proximity Sensors are located at the 70-ft. fold. The motions of the boom (folding and unfolding) are guided by the measured position of the different cylinders.

NOTE: The Proximity Sensors are factory-positioned and should not require calibration. Contact your local John Deere dealer if boom positioning assistance is needed.



Proximity Sensors
-Typical View

NORAC Sensors

CAUTION

Placing an object beneath the NORAC Sensors when the system is in automatic mode may result in unintended movement.

The boom is equipped with five (5) NORAC Sensors (two located at each folding section, two located on each outer boom extension, and one located on the transom) that measure boom height above ground. The sensors send a signal to the NORAC control system allowing for position corrections to keep the boom parallel to the ground and the crop, giving you a more consistent spray pattern.

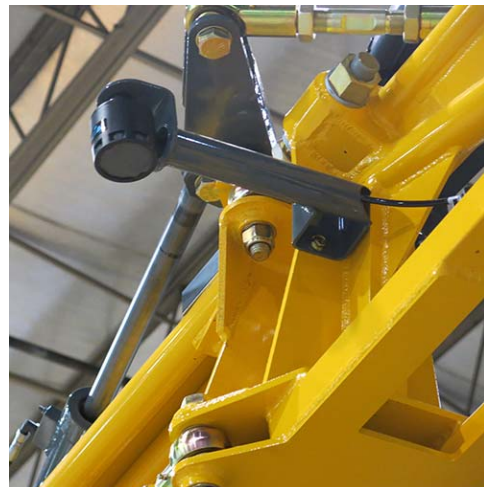

NORAC Sensor
-Typical View

Position Sensors

The level cylinders and main fold cylinders are equipped with Position Sensors. These sensors measure the linear stroke of the cylinder, allowing the boom to be positioned correctly when in Auto Fold mode.

The required specific motions exist to provide smooth, efficient operation. The programmed positions help prevent

mechanical damage to the boom due to severe imbalance, unintended contact with the ground, or improper fold sequence.

NOTE: The Position Sensors are factory-positioned and should not require calibration. Contact your local John Deere dealer if boom positioning assistance is needed.



Position Sensor
-Typical View

Accumulators

The level and lift cylinders (located on the transom) are equipped with multiple Accumulators. These Accumulators act as a “shock absorber” for the booms.



Accumulator
-Typical View

Main Pivot/Breakaway Cylinders

The Main Pivot/Breakaway Cylinders are responsible for the horizontal extension of the booms to the spray position. They also provide breakaway protection for the boom.

These breakaway cylinders will move backward to a maximum of 45-degrees in the event that the section encounters an obstacle.



Main Pivot/Breakaway Cylinders
-Typical View



Outer Breakaway (Tip)

A spring breakaway (located at the tip of the boom) moves forward, backward, and up to provide protection of the boom by allowing the boom to fold forward or backward in the event that it were to come into contact with another object.



Outer Breakaway
-Typical View

NOTE: The Outer Breakaway is self-resetting and will return to the normal operating position after it has cleared the hazard.



Adjusting Breakaway Tension

Recommended tension for the spring breakaway is 18”/45.7 cm (distance from the first coil to last coil, as shown).



Spring Breakaway
-Typical View

To increase/decrease spring tension:

- Using a 15/16” wrench or socket, loosen the Jam Nut.
- Using a 15/16” wrench or socket, tighten the Adjust Nut to extend the spring, or loosen the Adjust Nut to retract the spring.
- Re-tighten Jam Nut.

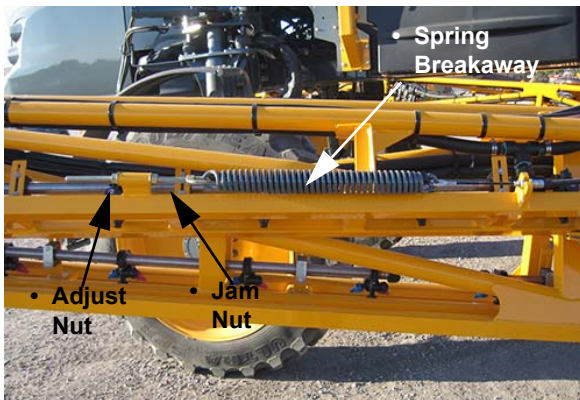

Spring Breakaway Adjust/Jam Nuts
(Located near the outer end of the spring breakaway)
-Typical View

Recharging Breakaway Circuits

Main Pivot/Breakaway Cylinders (Auto/Manual Mode)

To recharge Breakaway Circuits in Auto/Manual Mode, press the corresponding Left or Right-Hand Boom Switch (located on the Hydrostatic Drive Control Handle) in the OUT position.

NOTE: Right Extend OUT will recharge the breakaway circuits on the right-hand side of boom. Left Extend OUT will recharge the breakaway circuits on the left-hand side of boom.

Auto Fold

The Auto Fold feature is the preferred method for unfolding/folding the spray boom and makes operation of the machine easier for the operator.

NOTE: Ensure the Hydrostatic Drive Control Handle is in the NEUTRAL position. If the machine is put in gear during fold operation, boom movement will stop.

1. Press the Boom State Button (located on the Machine Display Auxiliary Controls Page) to the AUTO position.

NOTE: The selected boom state will illuminate.

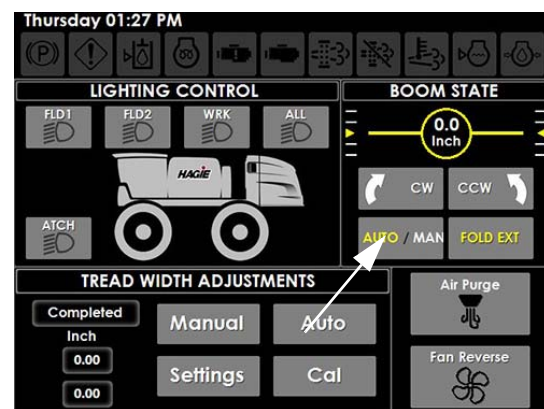

Boom State Button - Auto/Manual
(Located on the Machine Display Auxiliary Controls Page)

2. Press the Fold Extension Button (located on the Machine Display Auxiliary Controls Page) to the ON (illuminated) posi-

tion to enable Auto Fold operation of the outer boom extensions.

the side console) DOWN to fold the boom in to the fully retracted position.

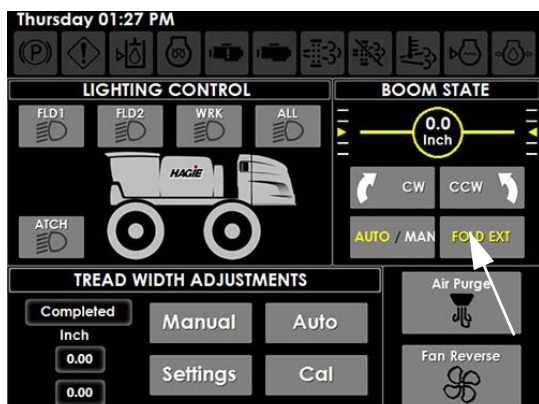

Fold Extension (Ext) Button
(Located on the Machine Display
Auxiliary Controls Page)

When the boom state displays AUTO and the Fold Extension Button is enabled, the boom will operate with the Boom Extension Switches (located on the side console).

NOTE: When the Fold Extension Button is disabled, the main boom will unfold/fold, but the outer boom extensions will not.

3. Press and hold **both** Left and Right Boom Extension Switches (located on the side console) UP to unfold the boom to the fully extended position on all sections.

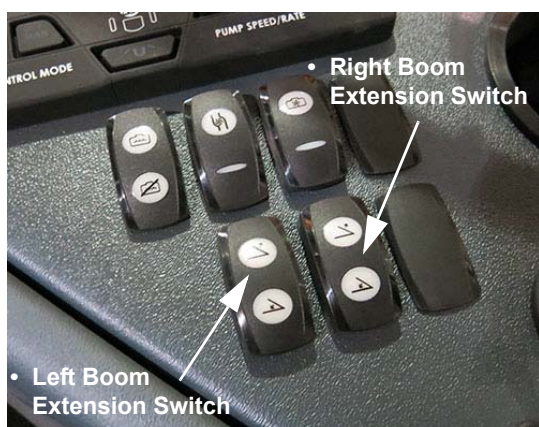

Left and Right Boom Extension Switches
(Located on the side console)
-Typical View

4. Press and hold **both** Left and Right Boom Extension Switches (located on

Manual Fold

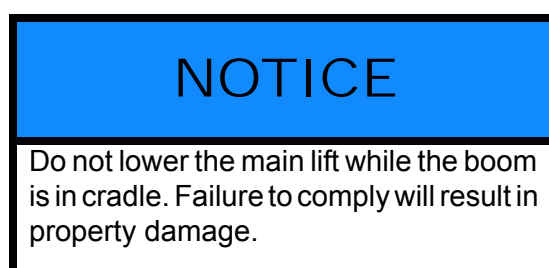
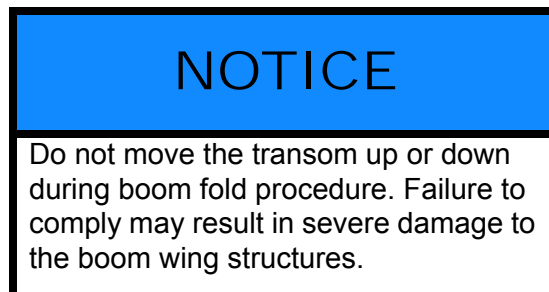

Unfolding/Extending the Boom

NOTE: Ensure the Hydrostatic Drive Control Handle is in the NEUTRAL position. If the machine is put in gear during fold operation, boom movement will stop.

1. Press the Boom State Button (located on the Machine Display Auxiliary Controls Page) to the MANUAL position.

NOTE: The selected boom state will illuminate.

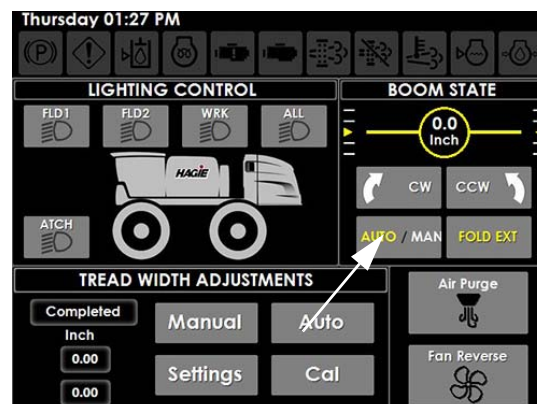

Boom State Button - Auto/Manual
(Located on the Machine Display
Auxiliary Controls Page)

2. Press and hold the corresponding Left and Right-Hand Boom Switches (located on the Hydrostatic Drive Control Handle) in the UP position to raise the level cylinders all the way up.

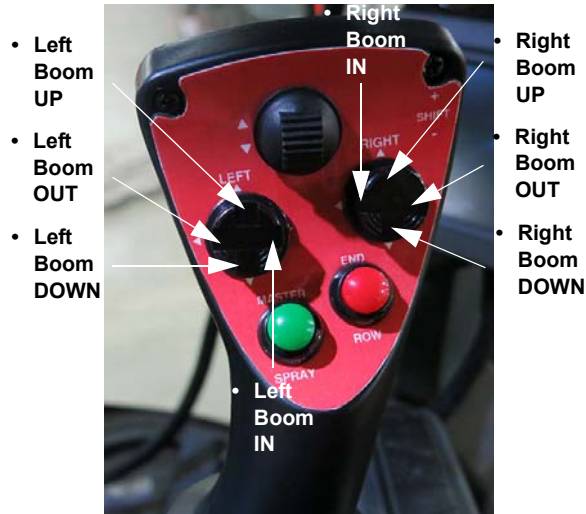

Left and Right-Hand Boom Switches
(Located on the Hydrostatic Drive Control Handle)
-Typical View

3. Press and hold the Left and Right-Hand Boom Switches in the OUT position to unfold the main boom sections until they come to a complete stop.

NOTE: Unfold booms simultaneously to prevent weight imbalance.

4. Lower the level cylinders until the boom is parallel with the ground.
5. Press and hold the Left and Right Boom Extension Switches (located on the side console) in the UP position to unfold the boom extensions all the way OUT.

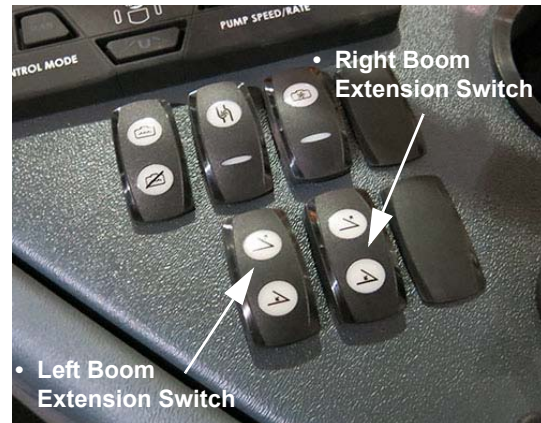

Left and Right Boom Extension Switches
(Located on the side console)
-Typical View

Folding/Retracting the Boom

NOTE: Ensure the Hydrostatic Drive Control Handle is in the NEUTRAL position. If the machine is put in gear during fold operation, boom movement will stop.

1. Press the Boom State Button (located on the Machine Display Auxiliary Controls Page) to the MANUAL position.

NOTE: The selected boom state will illuminate.

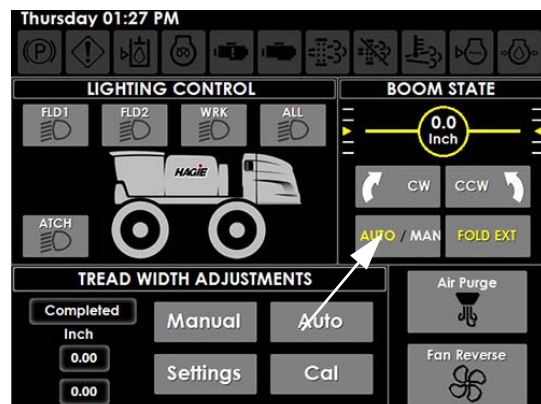

Boom State Button - Auto/Manual
(Located on the Machine Display Auxiliary Controls Page)

2. Lower the level cylinders until the boom is parallel with the ground.
3. Press and hold the Left and Right Boom Extension Switches (located on the side

console) in the DOWN position to fold the boom extensions all the way IN.

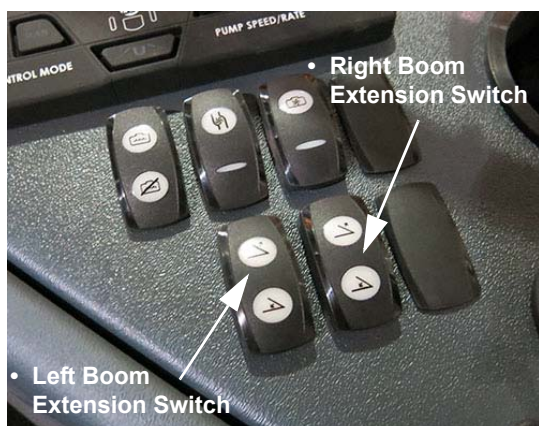

Left and Right Boom Extension Switches
(Located on the side console)
-Typical View

4. Raise the level cylinders all the way up.
5. Press and hold the Left and Right-Hand Boom Switches (located on the Hydrostatic Drive Control Handle) in the IN position until the main boom wings are aligned with cradles.

NOTE: Fold booms simultaneously to prevent weight imbalance.

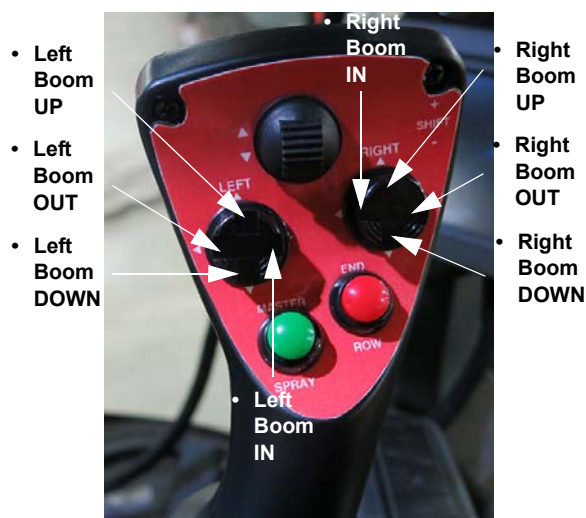

Left and Right-Hand Boom Switches
(Located on the Hydrostatic Drive Control Handle)
-Typical View

6. Lower the level cylinders until the boom sections are seated in the boom cradles.

Boom Alignment

When operating boom functions, the Boom Alignment value may be viewed on the Machine Display Auxiliary Controls Page.

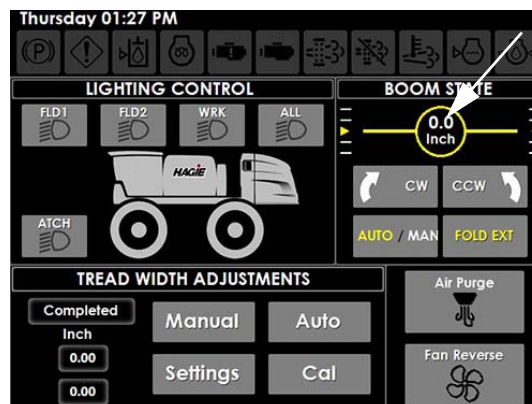

Boom Alignment Value
(Located on the Machine Display Auxiliary Controls Page)

Rolling Boom

The Rolling Boom feature will enable the boom to roll either “clockwise” or “counter-clockwise” (as viewed from the cab) using the Roll Command Buttons (located on the Machine Display Auxiliary Controls Page).

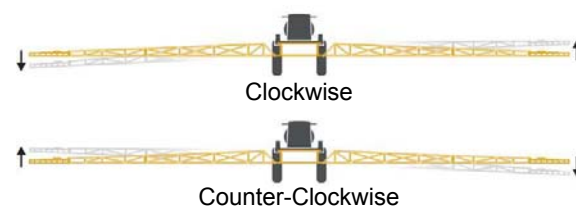

- Press and hold the “CW” Roll Command Button to roll the boom “clockwise”.
- Press and hold the “CCW” Roll Command Button to roll the boom “counter-clockwise”.

NOTE: The Roll Command Buttons will illuminate when held in the ON position and the current boom alignment value will be displayed.

- When either of the CW or CCW Roll Command Buttons are released, the boom will return to the neutral (center) position.

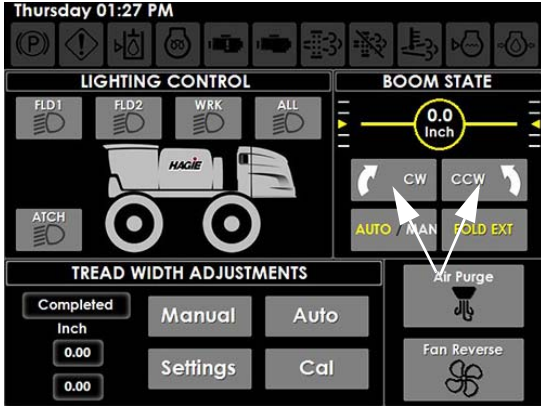

Roll Command Buttons (CW/CCW)
(Located on the Machine Display
Auxiliary Controls Page)

NOTE: Center position value is 0 inches/cm.

Enabling/Disabling NORAC® in the Pulse Display

-If Equipped

NOTE: Hagie Manufacturing Company recommends turning the NORAC Monitor OFF when traveling from one field to the next. A power switch is located on the back side of the monitor.



NORAC Monitor
-Typical View

- **To Enable**, press the corresponding Auto or Manual Button (located on the main “Run Screen”) to the ON (green illuminated position).

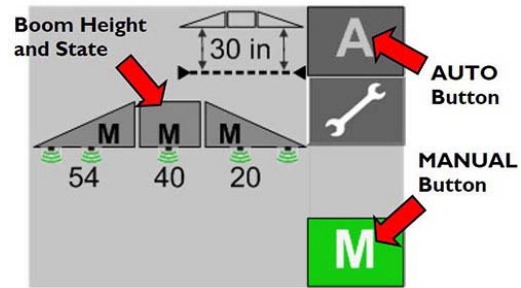

Auto/Manual Buttons - NORAC
(Located on the main “Run Screen”)
-Typical View

** Your monitor may vary in appearance, depending on model*

- **To Disable**, press the corresponding Auto or Manual Button to the OFF (gray) position or press any one of the following boom control switches (located on the Hydrostatic Drive Control Handle):
- Transom Switch (Up/Down)
- Left or Right-Hand Boom Switch (Up/Down)

NOTE: If the NORAC System becomes inoperable, the Auto and Manual Fold functions will still operate.

Enabling/Disabling NORAC in the Ag Leader® Display

-If Equipped

- **To Enable**, press the Auto/Manual Button (located on the main “Run Screen”) to the ON (green illuminated position).

NOTE: When the system is engaged, the boom image will change from black to blue.



Auto/Manual Button - Ag Leader
(Located on the main “Run Screen”)
-Typical View

** Your monitor may vary in appearance, depending on model*

- **To Disable**, press the Auto/Manual Button to the OFF (white) position or press any one of the following boom control switches (located on the Hydrostatic Drive Control Handle):
 - Transom Switch (Up/Down)
 - Left or Right-Hand Boom Switch (Up/Down)

NOTE: When the system is disabled, the boom image will change from blue to black.

NOTE: If the NORAC System becomes inoperable, the Auto and Manual Fold functions will still operate.

NORAC/Ag Leader System Settings

-If Equipped (Soil/Crop Mode, Target Height, and Sensitivity)

NOTE: Settings may be adjusted through the main Run Screen by pressing the Boom Image or the Settings Button (wrench icon), depending on model. Refer to the NORAC or Ag Leader manufacturer’s operation manual for further information.

Soil/Crop Mode

Soil Mode allows the sensors to read the height from the spray nozzles to the ground. Crop Mode allows the sensors to read the height from the spray nozzles to the top of the crop canopy.

On the NORAC Pulse Monitor:

- Press the Settings Button (wrench icon) (located on the main “Run Screen”) to navigate to the Settings Screen.
- Press the Next Button (located next to “Mode”) and select Soil, Crop, or Hybrid Mode.

NOTE: Hybrid Mode is an improved Crop Mode, which uses a combination of the crop and soil readings to improve control. This setting is recommended in place of Crop Mode.

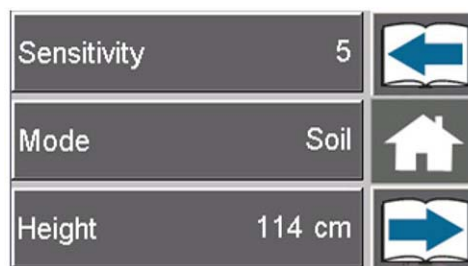

Settings Screen
(NORAC)
-Typical View

** Your monitor may vary in appearance, depending on model*

On the Ag Leader Monitor:

- Press the Boom Image (located on the main “Run Screen”).
- Press the top drop-down arrow (located on the Boom Height Control Options Screen) and select Soil or Crop Mode.

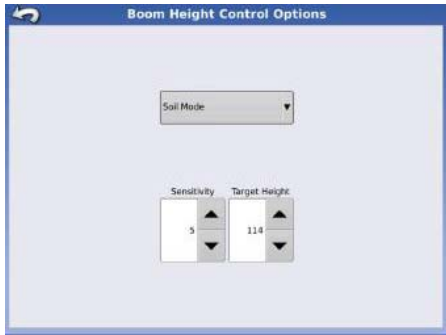

Boom Height Control Options Screen
(Ag Leader)
-Typical View

** Your monitor may vary in appearance, depending on model*

Sensitivity

Sensitivity is how responsive the system is. The lower the number, the lower the sensitivity. The higher the number, the higher the response time and hydraulic demand.

NOTE: Default sensitivity setting is 5.

On the NORAC Pulse Monitor:

- Press the Settings Button (wrench icon) (located on the main “Run Screen”) to navigate to the Settings Screen.
- Press the Next Button (located next to “Sensitivity”) and increase or decrease system sensitivity values from 1-10.

On the Ag Leader Monitor:

- Press the Boom Image (located on the main “Run Screen”).
- Press the Sensitivity Buttons (located on the Boom Height Control Options Screen) and increase or decrease system sensitivity values from 1-10.

Target Height

Target Height is the height you desire the boom to be set at when spraying.

NOTE: When operating in Soil Mode, the Target Height is measured from the spray nozzles to the soil. In Crop Mode, the target height is measured from the crop canopy to the spray nozzles.

On the NORAC Pulse Monitor:

- Press the Settings Button (wrench icon) (located on the main “Run Screen”) to navigate to the Settings Screen.
- Press the Next Button (located next to “Height”) and increase or decrease values to desired boom height.

On the Ag Leader Monitor:

- Press the Boom Image (located on the main “Run Screen”).
- Press the Target Height Buttons (located on the Boom Height Control Options Screen) and increase or decrease values to desired boom height.

Further Information

Refer to the NORAC or Ag Leader manufacturer’s operation manual for complete operating/calibration instructions, troubleshooting information, and safety precautions.

Refer to “Specifications” provided in the Introduction Section elsewhere in this manual for information on GPS dimensions on your machine.

Enabling NORAC through the End Row Management Switch

-If Equipped

(Typical View - appearance may vary, depending on model)

1. Program the End Row Management Switch (located on the Hydrostatic Drive Control Handle) through the Machine Display.
Refer to “Machine Display” provided in the Cab Section elsewhere in this manual for initial setup instructions.



End Row Management Switch
(Located on the Hydrostatic
Drive Control Handle)
-Typical View

2. On the NORAC or Ag Leader main “Run Screen”, press the “wrench” icon.

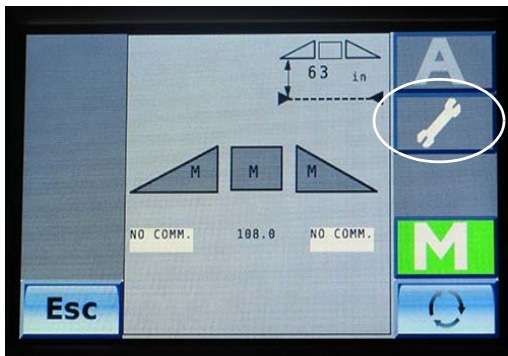

Main Run Screen
-Typical View

3. On the Settings Screen (1/3), press the “right/forward” blue arrow icon to navigate to the next screen.



Settings Screen (1/3)
-Typical View

4. On the Settings Screen (2/3), press the “right/forward” blue arrow icon to navigate to the next screen.
5. On the Settings Screen (3/3), press the “check page” icon.



Settings Screen (3/3)
-Typical View

6. On the Options Screen (1/5), ensure the “Remote Switches” option is selected and press the “right/forward” blue arrow icon to navigate to the next screen.

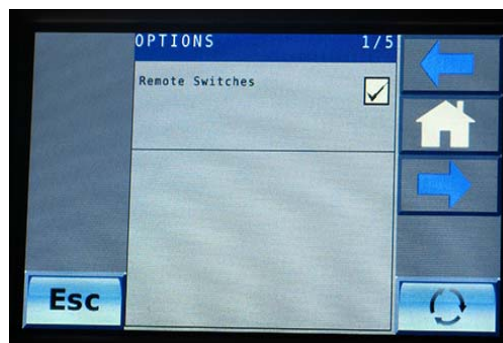

Options Screen (1/5)
-Typical View

7. On the Options Screen (2/5), select “Headland Assist”.



Options Screen (2/5)
-Typical View

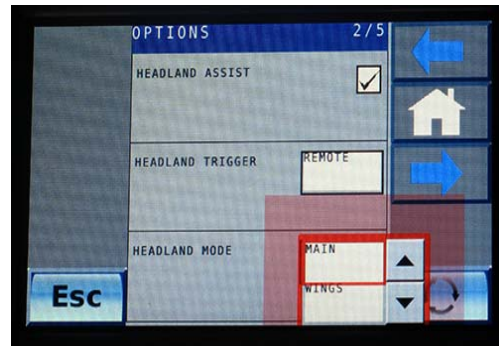

Options Screen (2/5)
-Typical View

8. On the Options Screen (2/5), press the selection area (next to “Headland Trigger”) and select REMOTE to enable NORAC through the End Row Management Switch.

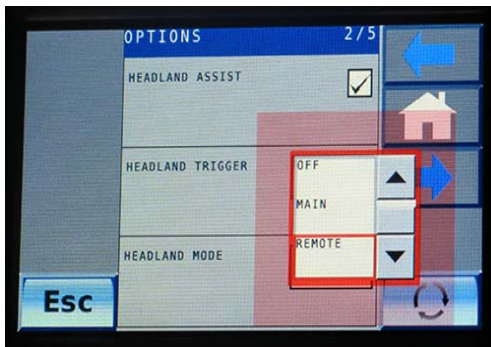

Options Screen (2/5)
-Typical View

SPRAY BOOM - REAR

-If Equipped

NOTE: The Rear Spray Boom is controlled through the center spray section of the front boom.



Rear Boom Installation
-Typical View

9. On the Options Screen (2/5), press the selection area (next to “Headland Mode”) and select MAIN or WINGS.

Installing the Rear Boom

NOTE: It is recommended that two persons install the Rear Boom.

1. Ensure solution supply is OFF.
2. Route solution line from the front boom to the rear boom (A).

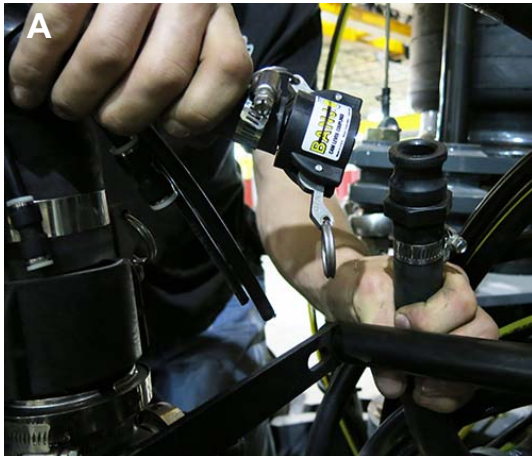

3. Rotate the 3-Way Boom Valve (B) (located on the center spray section of the front boom) to supply solution to the rear boom.
 - Rotate valve towards front of machine to supply solution to the front boom.
 - Rotate valve in the upright (vertical) position to shut solution supply OFF.
 - Rotate valve towards rear of machine to supply solution to the rear boom.

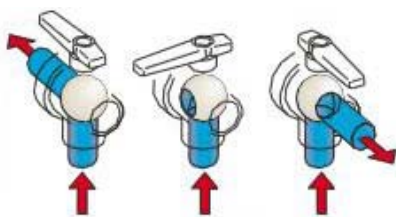
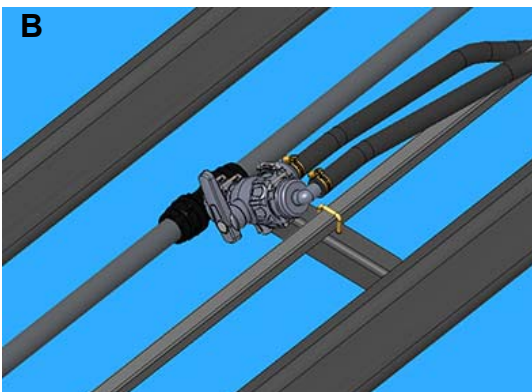

4. On both sides of machine, loosely install the Boom Mounting Bracket (C) to the underside of hood (D) and insert Rear Boom (E).

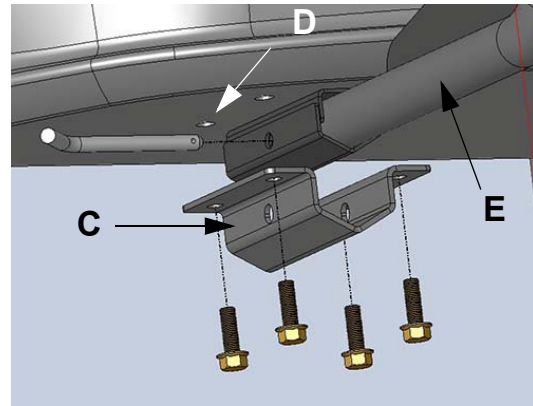

5. While maintaining position, install the Bent Pull Hitch Pin (F) through the aligned holes of the boom mounting assembly on each side.

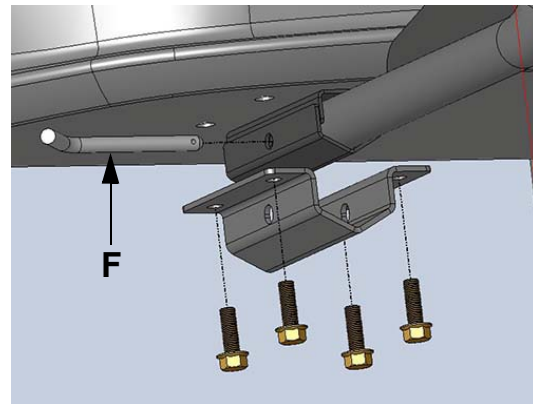

6. Ensuring the boom mounting hardware is aligned, hand-tighten the four (4) Boom Mounting Bolts (G) until snug on each side.

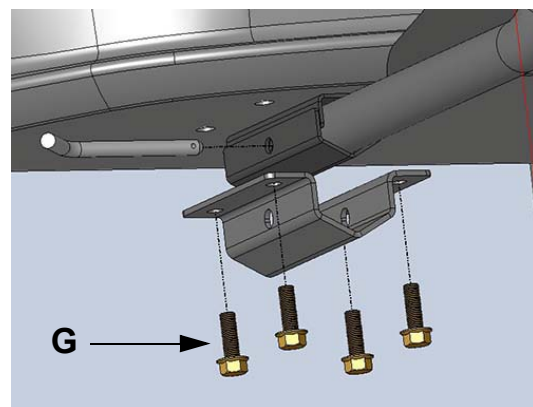

7. Install Hairpin (H) through the end of the previously installed Bent Pull Hitch Pin on each side.

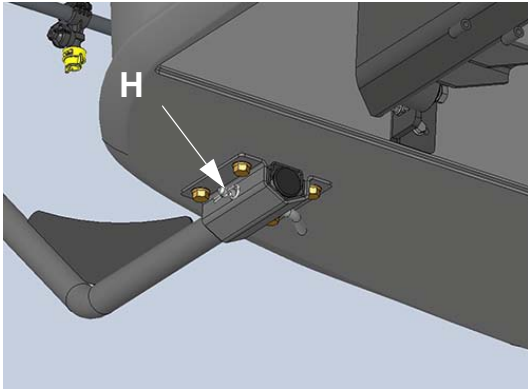

8. Using a 3/4" wrench, tighten the four (4) bolts to 68 ft.-lbs.
9. Connect the solution line with the Quick-Connect Fitting (I) (located beneath center of rear machine).

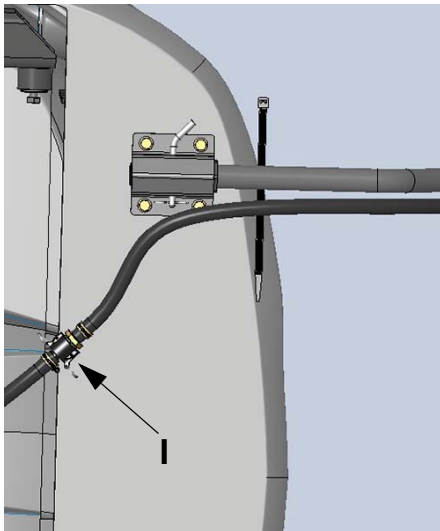

10. The Rear Spray Boom is now ready for use.



Removing the Rear Boom

1. Ensure solution supply is OFF.

2. Rotate the 3-Way Boom Valve (B) to the OFF (vertical) position.
3. Disconnect solution line from the Quick Connect Fitting (I).
4. Remove Hairpin (H) and Bent Pull Hitch Pin (F) and set aside.
5. Remove Rear Boom.
6. Reinstall the previously removed Hairpin and Bent Pull Hitch Pin to the mounting hardware.
7. Rotate the 3-Way Boom Valve (B) to supply solution to the front boom.

SOLUTION SYSTEM COMPONENTS

The Solution System is a constantly monitored, continuously adjusted computer-controlled system. The cab-mounted digital spray system console receives information from various inputs to help determine gallons per acre (GPA)/liters per hectare (l/ha) and gallons per minute (GPM)/liters per minute (l/min).

Please read and understand the information provided in this manual, as well as the spray system console manufacturer's operation manual before operating the Solution System. The following information refers to components of the Solution System and is not intended to replace the manufacturer's operating instructions.

- Solution Tank
- Solution Pump
- Solution Pump Switch
- Flow Meter
- Pressure Gauge
- Solution Tank Drain Valve
- Solution Tank Valve
- Main Tank Valve Switch
- Agitation Valve
- Agitation Valve Switch
- Jet Agitators
- Boom Solution Valve Switches
- Section Indicator Display
- Boom Solution Valve Indicators (Transom), if equipped
- Rate Control Switches
- Pump Speed/Rate Switches

- Master Spray Switch
- Spray System Console
- Air Purge (if equipped)
- Wet Booms
- Nozzle Bodies
- Section Strainers (if equipped)
- Solution Line Strainer

Solution Tank

The 1600-gallon (6056 L) stainless steel Solution Tank (located at the center of the machine) is equipped with a spin ball-type rinse system (two rotating rinse balls inside the tank). A mechanical sight gauge is located behind the left-hand side of cab to visually check solution level at all times.

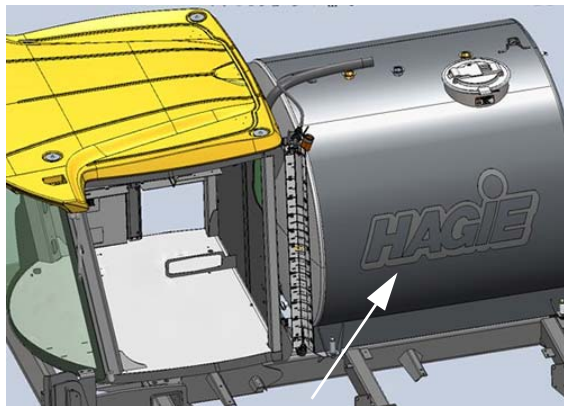

Solution Tank
-Typical View

Solution Pump

Hypro® 9306-HM1C-BU w/silicon carbide seals, 3" (7.6 cm) inlet/2" (5.1 cm) outlet plumbing

The Solution Pump (located beneath center of machine) is a centrifugal-type hydraulically driven pump that is controlled by the Solution Pump Control Valve and the Spray System Console.

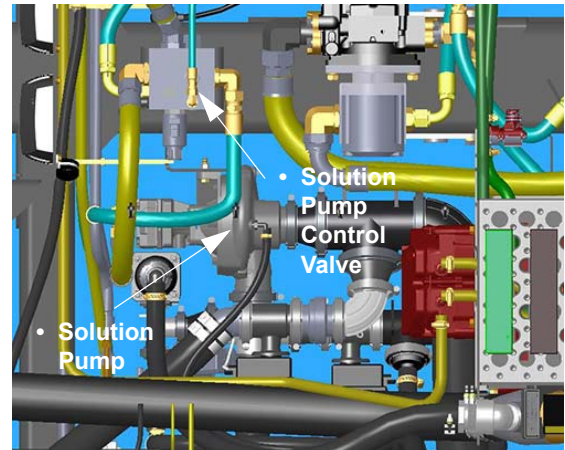

Solution Pump and
Solution Pump Control Valve
(Located beneath center of machine)
-Typical View

* View shown from top of machine

The Solution Pump draws solution out of the tank at the rate determined during calibration. It dispenses solution through the many valves and hoses that make up the spray system. The Solution Pump also dispenses fluids through the Agitation and Rinse Systems.

Refer to the Spray System Console manufacturer's operation manual for further information on Solution Pump control.

Solution Pump Switch

The Solution Pump Switch (located on the side console) is used to turn on/off the Solution Pump.

NOTE: Leaving the Solution Pump Switch in the ON position without flow may result in system damage.

- Press the Solution Pump Switch in the UP position to turn ON (enable).
- Press the Solution Pump Switch in the DOWN position to turn OFF (disable).



Solution Pump Switch
(Located on the side console)
-Typical View

NOTE: When the Solution Pump is ON, a Solution Pump Indicator (located on the Machine Display Home Page - Field Mode) will illuminate.



Solution Pump Indicator
(Located on the Machine Display
Home Page - Field Mode)

Flow Meter (ARAG® Orion)

The Flow Meter (located beneath the right-hand side of machine) is an electromagnetic-type with no internal moving parts, which monitors solution flow and sends information back to the Spray System Console.

NOTE: Flow Meter Usable Range = 3-190 GPM (11.4-719.2 l/min).

NOTE: Flow Meter Calibration = 378 pulses/ per gallon (standard volume system). Calibration is listed on the flow meter tag and may vary depending on options and available equipment.

NOTE: John Deere and Raven Controllers: Flow Meter Calibration = 3,780 pulses/per 10 gallons.

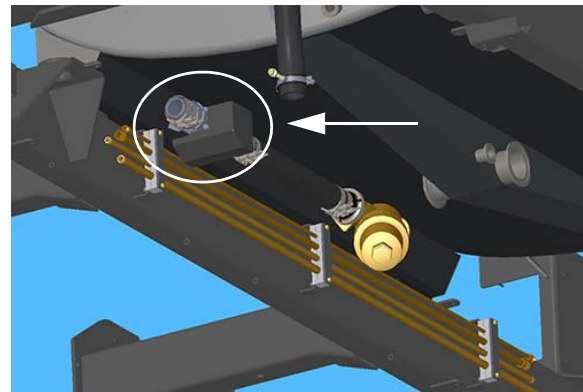

Flow Meter
(Located beneath the
right-hand side of machine)
-Typical View

Pressure Gauge

The Pressure Gauge (mounted on the boom) gives a constant visual display of solution pressure being applied (measured in PSI).

NOTE: Pressure will vary according to speed, application, rate, tip size, etc.



Pressure Gauge
(Mounted on boom)
-Typical View

Solution Tank Drain Valve

The Solution Tank Drain Valve (located beneath the solution tank on underside of machine) is used to drain small volumes of residual from the solution tank.

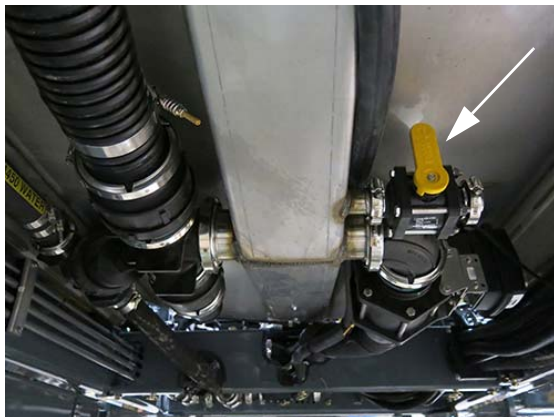

Solution Tank Drain Valve
(Located beneath the solution tank on underside of machine)
-Typical View

Refer to “Draining Your Solution Tank” elsewhere in this section for further information.

Solution Tank Valve (Main Tank)

The Solution Tank Valve (located beneath the solution tank on underside of machine) is an electric tank shut-off valve. This valve is controlled by the Main Tank Valve Switch (located on the side console).



Solution Tank Valve
(Located beneath the solution tank on underside of machine)
-Typical View

Main Tank Valve Switch

The Main Tank Valve Switch (located on the side console) controls the solution tank valve.

- Press the Main Tank Valve Switch in the UP (On) position to open the solution tank valve.
- Press the Main Tank Valve Switch in the DOWN (Off) position to close the solution tank valve.



Main Tank Valve Switch
(Located on the side console)
-Typical View

NOTE: Main Tank Valve status (OPEN or CLOSED) is displayed on the Machine Display Home Page - Field Mode.



Main Tank Valve Status Indicator
(Located on the Machine Display Home Page - Field Mode)

Agitation Valve

The flow rate of the Agitation System is controlled by an Agitation Valve (located near center of machine) to thoroughly mix solution in the tank and regulate pressure and flow to the jet agitators. Increase or decrease agitation flow by operating the Agitation Valve Switch (located on the side console).



Agitation Valve
(Located near center of machine)
-Typical View

** View shown from top of machine*

Agitation Valve Switch

The Agitation Valve Switch (located on the side console) is used to increase or decrease the agitation valve flow rate.



Agitation Valve Switch
(Located on the side console)
-Typical View

- **To increase flow**, press and hold the Agitation Valve Switch in the UP position.
- **To decrease flow**, press and hold the Agitation Valve Switch in the DOWN position.
- Release the Agitation Valve Switch when desired rate of flow is achieved.
- To turn the Agitation System OFF, decrease the flow rate all the way down.

NOTE: Agitation Valve pressure is displayed on the Machine Display Home Page - Road and Field Mode.



Agitation Valve Pressure Indicator
(Located on the Machine Display Home Page - Road and Field Mode)

Jet Agitators (2)

The Jet Agitators (located on each end of the solution tank) are an integral part of the Agitation System. 5/16” nozzles are located on the end of each Jet Agitator (inside of the solution tank) and provide ample agitation and solution suspension.



Jet Agitator
(Located on each end of the solution tank)
-Typical View

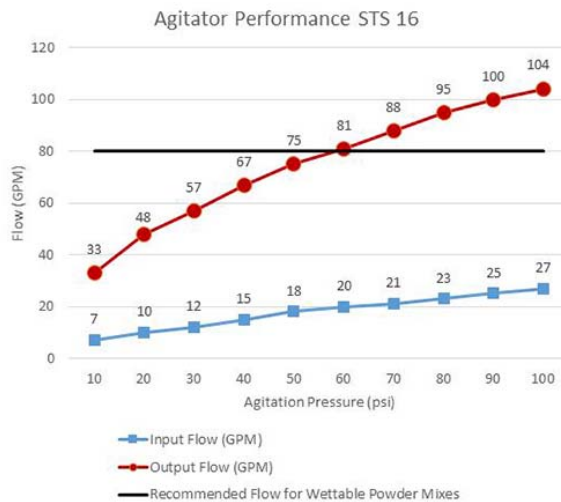

Boom Solution Valve Switches

The spray booms are divided into sections that are independently supplied with solution and can be turned on or off individually. The electrically-operated boom solution valves are controlled by the Boom Solution Valve Switches (located on the side console).

- Press the Boom Solution Valve Switches to turn ON. Press again to turn OFF.

NOTE: Each Boom Solution Valve Switch is equipped with an indicator light and will illuminate when the corresponding Boom Solution Valve is OFF.



Boom Solution Valve Switches
(Located on the side console)
-Typical View

Section Indicator Display

The Section Indicator Display (located on the cab headliner) allows you to view system status for the following:

- (1) - Master Spray Indicator (illuminates when ON).
- (2) - Fence Row Indicators (illuminate when ON).
- (9) - Spray Section Indicators (illuminate when OFF).
- (1) - Rear Wheel Nozzle Indicator (illuminates when ON).

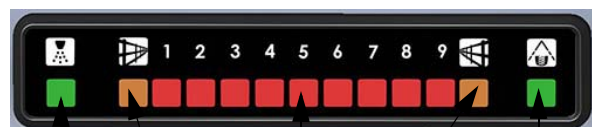

- Master Spray
- Left Fence Row
- Spray Section
- Right Fence Row
- Rear Wheel Nozzle

Section Indicator Display
(Located on the cab headliner)
-Typical View

Boom Solution Valve Indicators (Transom)

-If Equipped

Your machine may be equipped with transom-mounted Boom Solution Valve Indicators (located on the center of the transom), which allow you to view system status for the following:

- (2) - Fence Row Indicators (illuminate when ON).
- (1) - Master Spray Indicator (illuminates when ON).
- (9) - Spray Section Indicators (illuminate when OFF).



Boom Solution Valve Indicators
(Located on transom)
-Typical View

Rate Control Switches

The Rate Control Switches (located on the side console) control the rate in which solution is applied through the spray booms.

- Press ENABLE to allow the rate controller to control the application rate.
- Press MAN (Manual) to control application rate from the section keypad.
- Press ENABLE and MAN to enable manual rate control through the rate controller.



Rate Control Switches
(Located on the side console)
-Typical View

NOTE: When “MAN” is selected, press the Pump Speed/Rate Switches (located on the side console) to increase (+) or decrease (-) application rate. Current solution pump speed is displayed below the Solution Pump Indicator (located on the Machine Display Home Page - Field Mode).

Pump Speed/Rate Switches

The Pump Speed/Rate Switches (located on the side console) control the flow rate through the spray system.

NOTE: These switches are enabled when the “MAN” Rate Control Switch (located on the side console) is previously selected.

- Press “+” to INCREASE Solution Pump speed.
- Press “-” to DECREASE Solution Pump speed.



Pump Speed/Rate Switches
(Located on the side console)
-Typical View

NOTE: Increasing or decreasing pump speed will change the application rate through the rate controller.

Master Spray Switch

Boom solution valve switches are controlled by the Master Spray Switch (located on the Hydrostatic Drive Control Handle) and must be ON to open the electronically-operated boom solution valves.

This allows you to turn all of the boom solution valves on or off at the same time, such as turning them off when you reach the end rows, and turning them back on when you re-enter the field.



Master Spray Switch
(Located on the Hydrostatic Drive Control Handle)
-Typical View

NOTE: When the Master Spray Switch is ON, a Master Spray Indicator (located on the Machine Display Home Page - Field Mode) will illuminate.



Master Spray Indicator
(Located on the Machine Display Home Page - Field Mode)

Spray System Console

The spray system is controlled by the Spray System Console and the Solution Pump Control Valve. The system receives

data and automatically makes adjustments based on the target rate of application set by the operator.

Refer to the Spray System Console manufacturer’s operation manual for complete calibration and operating instructions.



Spray System Console
-Typical View

(Your machine may vary according to model and available equipment)

Air Purge

-If Equipped

The Air Purge feature on your machine allows you to blow out product from the spray system. You may choose to perform the air purge in either manual or automatic mode.

In **Manual Mode**, the operator has control of the solution valves by manipulating the Boom Solution Valve Switches (located on the side console section keypad).

In **Automatic Mode**, the air tank on the machine is filled based on engine speed and time to automatically recharge the air tank and purge the spray system. Automatic Air Purge settings include: Full Boom Purge, Individual Section Purge, Air Recharge Time, and Minimum Engine Speed.

Refer to “Machine Display” provided in the *Cab Section* elsewhere in this manual for further information on adjusting Air Purge settings and operating instructions.

Wet Boom

The 9-section Wet Boom on your machine is featured with 1” (2.5 cm) schedule 5 stainless plumbing and delivers solution directly to the spray nozzles, which allows for ease of flushing and cleaning of the boom, as well as decreased contamination/plugging of nozzles.

The Wet Booms are equipped with Hypro® Express end caps on the end of the boom tubing, which aid in eliminating trapped air from the boom by allowing air to escape through the nozzle body, reducing nozzle turn-off time. The end caps are equipped with a “quick-release” feature to assist in flushing the Wet Boom tubes.



Wet Boom Plumbing
-Typical View



Hypro Express End Cap
-Typical View

Refer to “Spray Booms” elsewhere in this section for further information.

Nozzle Bodies

Nozzle Bodies are located throughout the boom and consist of a spray tip, gasket, and cap. The spray tip breaks the solution into droplets of correct size and forms a uniform spray pattern.



Nozzle Body
(Located throughout boom)
-Typical View

Visit www.teejet.com for further information.

Section Strainers

-If Equipped (80-Mesh Strainer Screens)

Section Strainers are located throughout each boom section and filter impurities to aid in the avoidance of spray nozzle buildup.

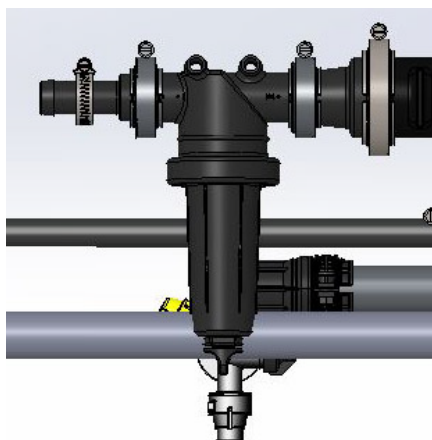

Section Strainers
(Located throughout each boom section)
-Typical View

Refer to “Service - Filters” provided in the *Maintenance and Storage Section* elsewhere in this manual for maintenance information.

Solution Line Strainer

(50-Mesh Strainer Screen)

A Solution Line Strainer is located beneath the center right-hand side of machine and is the main strainer to filter solution system impurities and maintain consistent application rates.



Solution Line Strainer
(Located beneath the center
right-hand side of machine)
-Typical View

Refer to “Service - Filters” provided in the *Maintenance and Storage Section* elsewhere in this manual for maintenance information.

SOLUTION SYSTEM - OPERATION

NOTICE

The Solution System has been tested using RV-type antifreeze. Fill solution tank with fresh water and drain before initial use.

NOTICE

Never attempt to operate the spray system without solution in the tank. Failure to comply will cause severe equipment damage and will void the warranty.

NOTE: Ensure the Master Spray Switch (located on the Hydrostatic Drive Control Handle) is in the OFF position before activating the Solution Pump Switch or the Boom Solution Valve Switches, unless you are ready to begin spray application.

Getting Started

1. Calibrate the Spray System Console (refer to the manufacturer's operation manual for calibration instructions).
2. Ensure there is adequate amount of solution in the tank.
3. Engage the parking brake.
4. Start the engine.
5. Press the Field/Road Button (located on the Machine Display Home Page) and change the machine's drive state to FIELD.

NOTE: The drive state of the machine cannot be changed unless the Hydrostatic Drive Control Handle is in the NEUTRAL position (and machine speed is less than 0.5 mph/ 0.8 km/h).

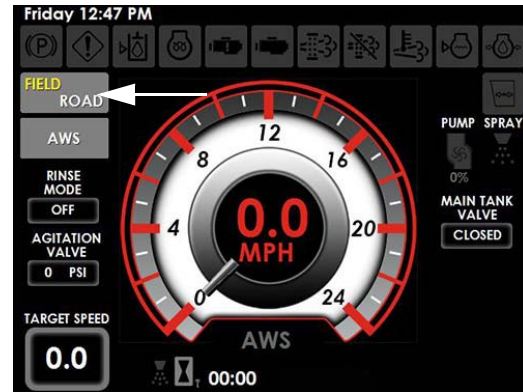

Field/Road Button
(Located on the
Machine Display Home Page)

NOTE: The selected drive state will illuminate.

6. Position boom to desired position.
7. Press the Main Tank Valve Switch (located on the side console) in the UP (Open) position. If desired, activate the Agitation Valve Switch (located on the side console). Press and hold switch UP to increase flow, or DOWN to decrease flow.

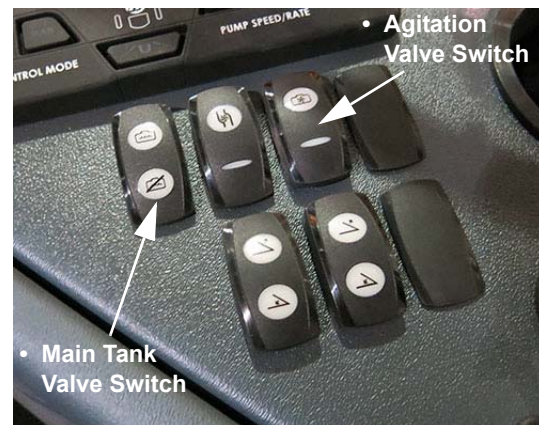

Main Tank and Agitation Valve Switches
(Located on the side console)
-Typical View

NOTE: Main Tank Valve status (OPEN or CLOSED) and Agitation Valve pressure are displayed on the Machine Display Home Page (Field Mode).

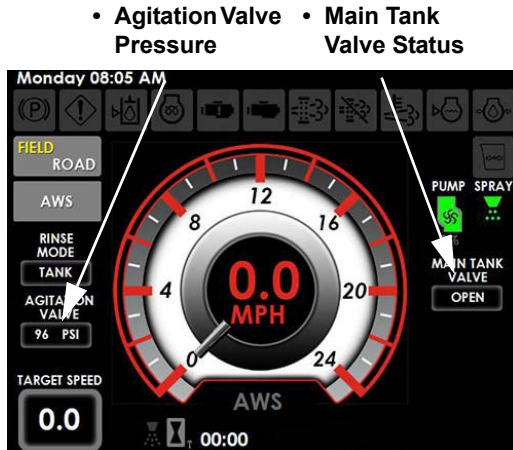

Main Tank Valve Status and Agitation Valve Pressure Indicators (Located on the Machine Display Home Page - Field Mode)



Rate Control and Pump Speed/Rate Switches (Located on the side console) -Typical View

8. Press desired Rate Control Switch (located on the side console).
 - Press ENABLE to allow the rate controller to control application rate.
 - Press MAN (Manual) to control application rate from the section keypad.
 - Press ENABLE and MAN to enable manual rate control through the rate controller.

NOTE: When “MAN” is selected, press the Pump Speed/Rate Switches (located on the side console) to increase (+) or decrease (-) application rate. Current solution pump speed is displayed below the Solution Pump Indicator (located on the Machine Display Home Page - Field Mode).

NOTE: Increasing or decreasing pump speed will change the application rate through the rate controller.

9. Press the Solution Pump Switch (located on the side console) in the UP (On) position.

NOTICE

Do not allow the Solution Pump to run continuously while the Boom Solution Valve Switches are off. Failure to comply will generate overheating, causing severe pump damage and will void the warranty.



Solution Pump Switch (Located on the side console) -Typical View

- Turn the Master Spray Switch (located on the Hydrostatic Drive Control Handle) ON.



Master Spray Switch
(Located on the Hydrostatic Drive Control Handle)
-Typical View

NOTE: When the Master Spray Switch is ON, a Master Spray Indicator (located on the Machine Display Home Page - Field Mode) will illuminate.



Master Spray Indicator
(Located on the Machine Display Home Page - Field Mode)

- Press the individual Boom Solution Valve Switches (located on the side console) to the ON (non-illuminated) position.

NOTE: Each Boom Solution Valve Switch is equipped with an indicator light and will illuminate when the corresponding Boom Solution Valve is OFF.



Boom Solution Valve Switches
(Located on the side console)
-Typical View

- Slowly move the Hydrostatic Drive Control Handle forward to obtain desired ground speed.
- Frequently observe the pressure gauge. If the pressure drops to zero or spray pattern deteriorates, turn OFF the Master Spray, Solution Pump, Main Tank Valve, and Agitation Valve Switches until solution is refilled.

FENCE ROW APPLICATOR

To Operate the Fence Row Nozzles

NOTE: Boom Solution Valves 1 or 9 must be in the ON position in order to enable the Fence Row Switches.

- Press the desired Fence Row Switch - Left or Right (located on the side console) to turn ON. Press switch again to turn OFF.

NOTE: The corresponding Fence Row Switch will illuminate when active.



Fence Row Switches - Left and Right
(Located on the side console)
-Typical View

To Operate the Rear Nozzles

NOTE: The center section of the boom must be in the ON position in order to enable the Rear Nozzles.

The Rear Nozzle Switch (located on the side console) controls the two (2) rear nozzles (located behind the tires).

- Press the Rear Nozzle Switch to turn ON. Press switch again to turn OFF.

NOTE: The Rear Nozzle Switch will illuminate when active.



Rear Nozzle Switch
(Located on the side console)
-Typical View

FILLING YOUR SOLUTION TANK

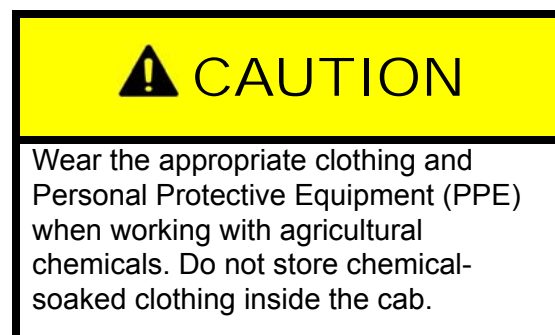

Front Fill

Filling the Solution Tank

1. Pull the Front Fill Release Lever (located beneath front end of machine) OUT (toward operator) to unlock the Front Fill Assembly.

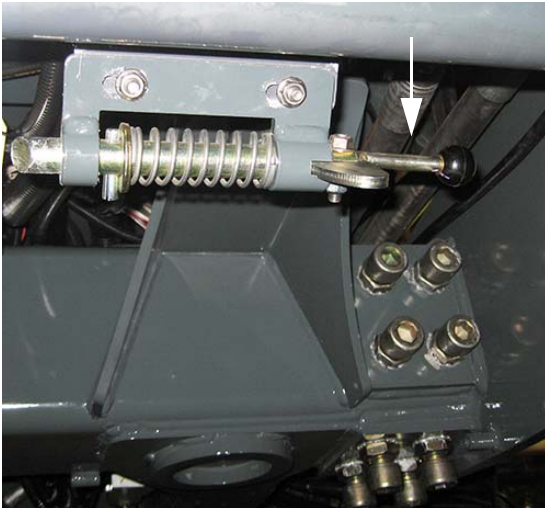

Front Fill Release Lever
(Located beneath front end of machine)
-Typical View

2. Lower the Front Fill Assembly.

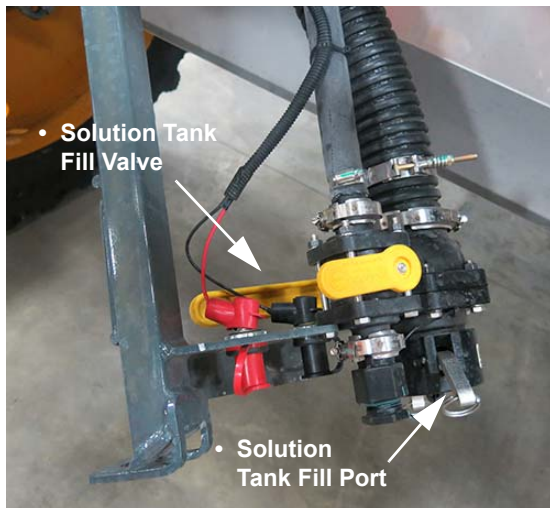

Front Fill Assembly
(Lowered position shown)
-Typical View

3. Remove fill port cap and connect solution supply to the Solution Tank Fill Port.

4. Rotate Solution Tank Fill Valve to the OPEN position and fill tank to desired level.

NOTE: Two power ports (located near the front fill assembly) are provided for chemical pump connection.

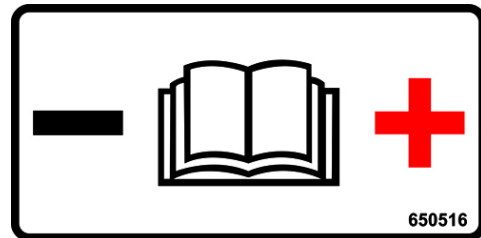

Power Ports
(Located near front fill assembly)
-Typical View

5. **When finished filling the tank**, close the Solution Tank Fill Valve.
6. Remove solution supply from the Solution Tank Fill Port.
7. Reinstall fill port cap.
8. Raise the Front Fill Assembly to stored position, ensuring it “clicks” into locked position.

Filling the Rinse Tank

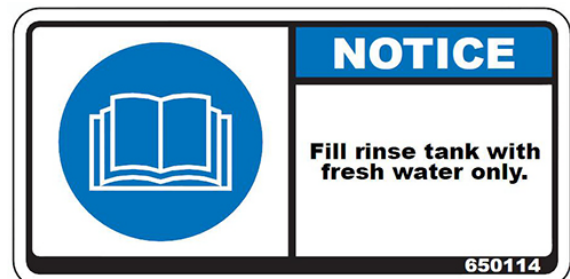

*NOTE: Rinse Tank Capacity = 100 gallons
(378.5 L).*

1. Pull the Front Fill Release Lever (located beneath front end of machine) OUT (toward operator) to unlock the Front Fill Assembly.



Front Fill Release Lever
(Located beneath front end of machine)
-Typical View

2. Lower the Front Fill Assembly.



Front Fill Assembly
(Lowered position shown)
-Typical View

3. Remove fill port cap from the Rinse Tank Fill Port.
4. Connect operator-supplied connection to the Rinse Tank Fill Port.
5. Rotate Rinse Tank Fill Valve to the OPEN position and fill tank to desired level.
6. **When finished filling the tank**, close the Rinse Tank Fill Valve.
7. Remove operator-supplied connection from the Rinse Tank Fill Port.
8. Reinstall the fill port cap.
9. Raise the Front Fill Assembly to the stored position, ensuring it “clicks” into locked position.

Rinsing the Front Fill

1. Remove Solution Tank Fill Port cap.
2. Attach fresh water supply connection to Solution Tank Fill Port.
3. Turn fresh water supply ON.
4. Rotate the Solution Tank Fill Valve in the OPEN position.
5. **When rinsing is complete**, turn fresh water supply OFF.
6. Close the Solution Tank Fill Valve.
7. Remove fresh water supply connection from the Solution Tank Fill Port and reinstall cap.

Side Fill

-If Equipped

NOTE: Engage parking brake before operating the side fill.

Filling the Solution Tank (Inductor Operation)

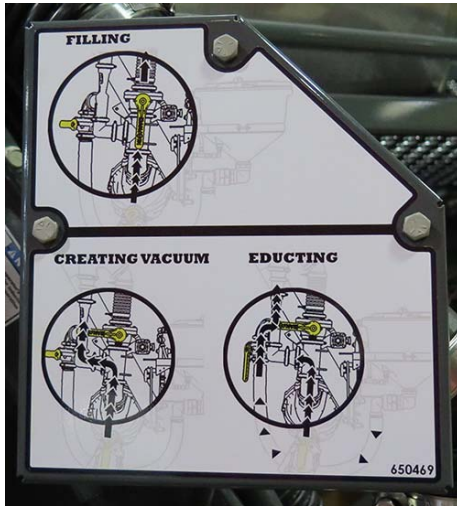

Side Fill Operation Label
(Located near side fill assembly)
-Typical View

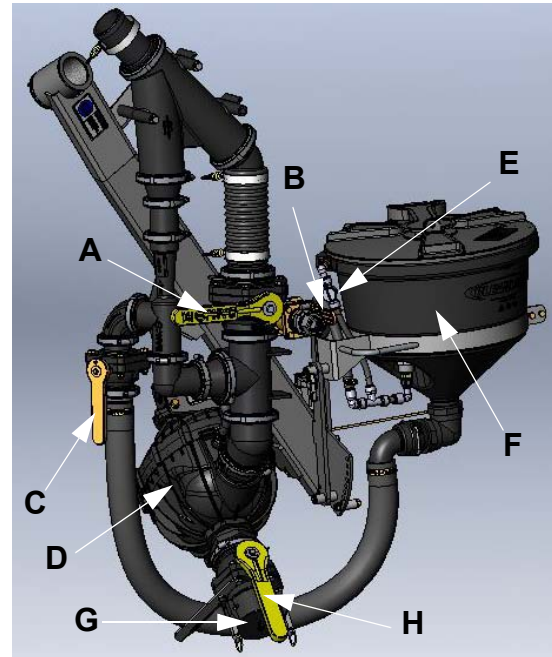

Inductor Assembly
-Typical View

Inductor Assembly Components

- (A) - Side Fill Valve
- (B) - Rinse Supply Valve
- (C) - Chemical Inductor Valve
- (D) - Transfer Pump
- (E) - Swirl Valve
- (F) - Chemical Inductor Tank
- (G) - Fill Port
- (H) - Fill Valve
- (I) - Pump Speed Switch
- (J) - Raise/Lower Switch
- (K) - Pump Activation Lever
- (L) - Power Ports

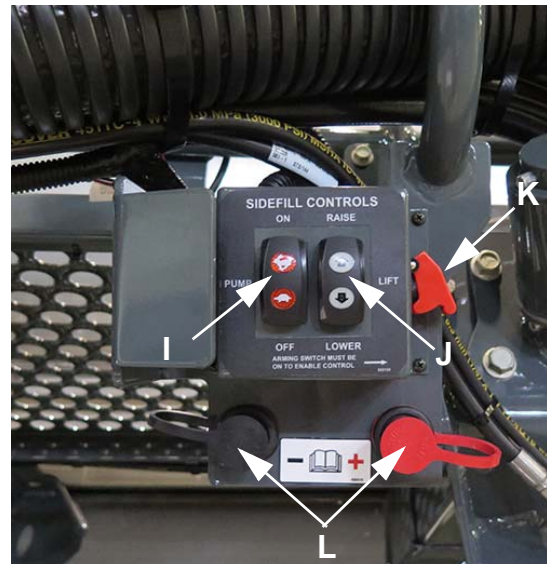

Side Fill Control Panel
-Typical View

NOTE: Two power ports (L) are provided for chemical pump connection.

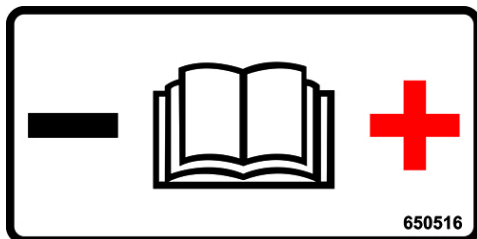

1. Engage the parking brake.
2. Start the engine.
3. Lift the Pump Activation Lever (K) UP.
4. Lower the Inductor Assembly by pressing the Raise/Lower Switch (J) in the DOWN (Lower) position.
5. Press the Pump Speed Switch (I) in the UP (On) position ONCE to activate the Transfer Pump.
6. Press and hold the Pump Speed Switch UP to increase speed or DOWN to decrease speed.

NOTE: Engine speed automatically increases to 1500 RPM at maximum pump speed.

NOTE: Always match pump speed to available supply to avoid pump damage.

NOTE: Whether filling with the Transfer Pump or an off-site pump, ensure the Transfer Pump is running.

7. Press and hold the Pump Speed Switch in the DOWN (Off) position when filling is complete.
8. Push the Pump Activation Lever DOWN.

NOTE: The following procedures are the same for either a sprayer-mounted transfer pump or a nurse tank pump.

Fill Water Only

- Fill Port (G) - *CONNECTED*
- Fill Valve (H) - *OPEN*
- Chemical Inductor Valve (C) - *CLOSED*
- Side Fill Valve (A) - *OPEN*
- Swirl Valve (E) - *CLOSED*

Fill Water/Induct Chemical

- Fill Port (G) - *CONNECTED*
- Fill Valve (H) - *OPEN*
- Side Fill Valve (A) - *CLOSED*
- Chemical Inductor Valve (C) - *OPEN* (after flow is established)

Fill Water/Induct Dry Chemical

- Fill Port (G) - *CONNECTED*
- Fill Valve (H) - *OPEN*
- Side Fill Valve (A) - *CLOSED*
- Swirl Valve (E) - *OPEN*

NOTE: Allow water to fill chemical tank approximately 3 inches (7.6 cm) before adding dry chemical. Add dry chemical with the Swirl Valve (E) OPEN. Open the Chemical Inductor (E) after dry chemical has been added.

Fill Rinse Tank

- Rinse Supply Valve (B) - *OPEN*

Rinse Inductor Tank

- Swirl Valve (E) - *OPEN*

NOTE: Before raising the Inductor Assembly, the Chemical Inductor Tank must be in the LOCKED position.

Rinsing the Side Fill

1. Remove Fill Port cap.
2. Attach fresh water supply connection to Fill Port.
3. Turn fresh water supply ON.
4. Rotate the Fill Valve (H) in the OPEN position.
5. Rotate the Side Fill Valve (A) in the OPEN position.
6. **When rinsing is complete**, turn fresh water supply OFF.
7. Close the Fill Valve and Side Fill Valve.
8. Remove fresh water supply connection from Fill Port and reinstall cap.

Rear Fill

-If Equipped

Filling the Solution Tank

1. Remove fill port cap and connect solution supply to the Solution Tank Fill Port (located behind rear left-hand wheel).



Rear Fill Assembly
(Located behind rear left-hand wheel)
-Typical View

2. Rotate Solution Tank Fill Valve to the OPEN position and fill tank to desired level.
3. **When finished filling the tank**, close the Solution Tank Fill Valve.
4. Remove solution supply from the Solution Tank Fill Port.
5. Reinstall fill port cap.

Filling the Rinse Tank

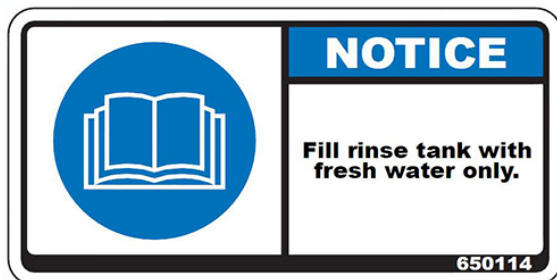

NOTE: Rinse Tank Capacity = 100 gallons (378.5 L).

1. Remove fill port cap from the Rinse Tank Fill Port.



Rear Fill Assembly
(Located behind rear left-hand wheel)
-Typical View

2. Connect operator-supplied connection to the Rinse Tank Fill Port.
3. Rotate Rinse Tank Fill Valve to the OPEN position and fill tank to desired level.
4. **When finished filling the tank**, close the Rinse Tank Fill Valve.
5. Remove operator-supplied connection from the Rinse Tank Fill Port.
6. Reinstall the fill port cap.

Rinsing the Rear Fill

1. Remove Solution Tank Fill Port cap.
2. Attach fresh water supply connection to Solution Tank Fill Port.
3. Turn fresh water supply ON.
4. Rotate the Solution Tank Fill Valve in the OPEN position.
5. **When rinsing is complete**, turn fresh water supply OFF.
6. Close the Solution Tank Fill Valve.
7. Remove fresh water supply connection from the Solution Tank Fill Port and reinstall cap.

Solution Tank Sight Gauge

A Solution Tank Sight Gauge is located behind the rear left-hand side of cab to visually check fluid level at all times from all three fill locations.



Solution Tank Sight Gauge
(Located behind the rear
left-hand side of cab)
-Typical View

DRAINING YOUR SOLUTION TANK

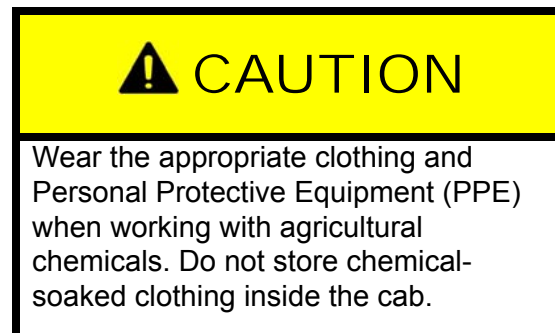
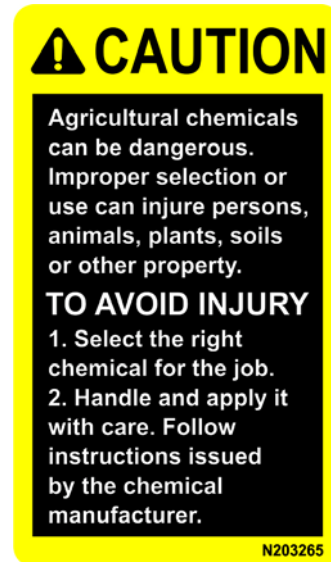

To Drain the Solution Tank

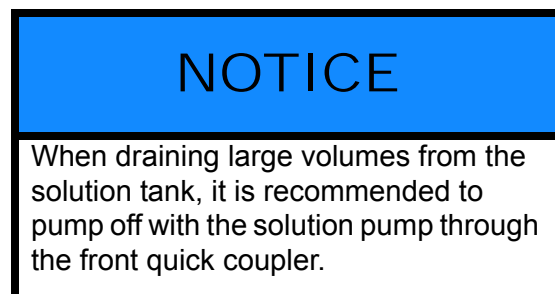

1. Loosen the metal flange clamp and remove Drain Valve Plug (located on the end of the Solution Tank Drain Valve Assembly).

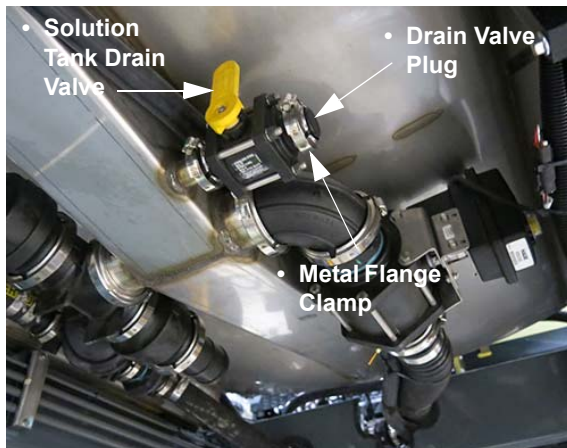

Solution Tank Drain Valve Assembly
(Located beneath the solution
tank on underside of machine)
-Typical View

2. Attach an operator-supplied hose to the end of the Solution Tank Drain Valve Assembly (where Drain Valve Plug was previously removed).
3. Turn the Solution Tank Drain Valve in the OPEN (counter-clockwise) position and allow solution to drain into an appropriate container for storage.

NOTE: Always ensure that storage containers and clearly marked with what type of chemical is being stored.

4. **When finished draining the solution tank**, turn the Solution Tank Drain Valve in the CLOSE (clockwise) position.
5. Remove hose from the Solution Tank Drain Valve Assembly.
6. Tighten metal flange clamp.

RINSE SYSTEM

Your machine is equipped with a spin ball-type Rinse System (two rotating rinse balls located inside of the solution tank) to easily and effectively rinse the solution tank, solution pump, and spray booms with fresh water, which protects against cross-contamination of chemicals, as well as reduces the risk of operator exposure. With a 100-gallon (378 L) rinse tank (mounted on top of the solution tank) full of fresh water,

you may rinse the sprayer out immediately after spraying while still in the field. The Rinse System also reduces the extra costs of large volumes of water, as well as additional refilling and sprayer time that are associated with conventional tank rinsing.

NOTE: Ensure the solution tank is completely empty before activating the Rinse System.

NOTICE

Select a safe area to rinse the spray system and clean the sprayer where chemicals will not drift off to contaminate people, animals, vegetation, or water supply.

NOTICE

Never attempt to operate the Rinse System without fresh water in the rinse tank. Failure to comply will result in equipment damage and will void the warranty.

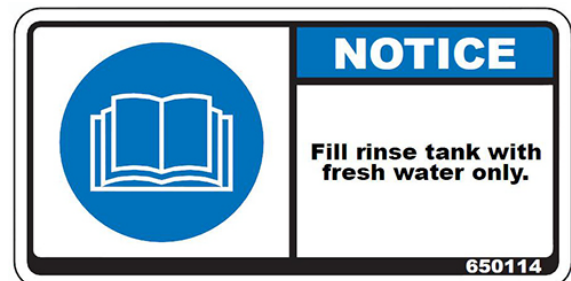

Refer to the chemical manufacturer's information for types of cleaning solution combinations (water, cleaning agents, etc.)

Step 1 - Rinsing the Solution Tank

1. Press the Main Tank Valve Switch (located on the side console) in the DOWN (Close) position.



Main Tank Valve Switch
 (Located on the side console)
 -Typical View

2. Press the Rinse Switch (located on the side console) in the DOWN position to rinse the solution tank.



Rinse Switch
 (Located on the side console)
 -Typical View

NOTE: A Rinse Mode Indicator is located on the Machine Display Home Page - Field Mode and will display current rinse mode status (TANK or BOOM).



Rinse Mode Indicator
 (Located on the Machine Display
 Home Page - Field Mode)

3. Press the Agitation Valve Switch (located on the side console) in the UP (Open) position.



Agitation Valve Switch
 (Located on the side console)
 -Typical View

4. Press the Solution Pump Switch (located on the side console) in the UP (On) position.



Solution Pump Switch
(Located on the side console)
-Typical View



“+” Pump Speed/Rate Switch
(Located on the side console)
-Typical View

5. Press the Manual (MAN) Rate Control Switch (located on the side console).

NOTE: Ensure the Enable Rate Control Switch is in the OFF position.



Manual “MAN” Rate Control Switch
(Located on the side console)
-Typical View

6. Press the “+” Pump Speed/Rate Switch (located on the side console) to increase solution pressure to desired PSI (bar).

7. When finished rinsing the solution tank, press the Rinse Switch to the OFF (mid) position.

Step 2 - Spray Diluted Water from Tank

1. Press the Agitation Valve Switch (located on the side console) in the DOWN (Close) position.
2. Press the Main Tank Valve Switch (located on the side console) in the UP (Open) position.
3. Press the Boom Solution Valve Switches (located on the side console) in the ON position.

NOTE: Each Boom Solution Valve Switch is equipped with an indicator light and will illuminate when the corresponding Boom Solution Valve is OFF.



Boom Solution Valve Switches
(Located on the side console)
-Typical View



Main Tank Valve Switch
(Located on the side console)
-Typical View

4. Press the Master Spray Switch (located on the Hydrostatic Drive Control Handle) in the ON position.
5. Continue spraying until all diluted water is removed from tank.

NOTE: When rinsing the boom and nozzles, ensure the Boom Solution Valve Switches (located on the side console) are in the ON position before activating the Rinse Switch.

2. Press the Rinse Switch (located on the side console) in the UP position to rinse the boom and nozzles.

NOTICE

Do not allow the solution pump to run dry for a prolonged period of time. Failure to comply may result in pump damage.

Step 3 - Rinsing the Boom and Nozzles

1. Press the Main Tank Valve Switch (located on the side console) in the DOWN (Close) position.



Rinse Switch
(Located on the side console)
-Typical View

NOTE: A Rinse Mode Indicator is located on the Machine Display Home Page - Field Mode and will display current rinse mode status (TANK or BOOM).



Rinse Mode Indicator
(Located on the Machine Display
Home Page - Field Mode)

3. Press the Manual (MAN) Rate Control Switch (located on the side console).



Manual “MAN” Rate Control Switch
(Located on the side console)
-Typical View

4. Press the “+” Pump Speed/Rate Switch (located on the side console) to increase the solution pressure to desired PSI (bar).



“+” Pump Speed/Rate Switch
(Located on the side console)
-Typical View

5. Press the Master Spray Switch (located on the Hydrostatic Drive Control Handle) in the OFF position.
6. Press the Solution Pump Switch (located on the side console) in the DOWN (Off) position.
7. When rinsing is complete, press the Rinse Switch to the OFF (mid) position.

FOAM MARKER SYSTEM

- If Equipped

CAUTION

Maximum foam regulator pressure is 20 PSI (1.4 bar). Use of higher pressure may cause personal injury and system damage and will void the warranty.

The Foam Marker system increases efficiency in the field when spraying by utilizing water from the rinse tank and mixing with the foam concentrate from the foam reservoir.

Filling the Foam Marker Reservoir

NOTE: Foam Marker Reservoir capacity = 1 gallon (3.8L).

1. Lift the Foam Marker reservoir fill cap (located on top of the Foam Marker reservoir fill port).

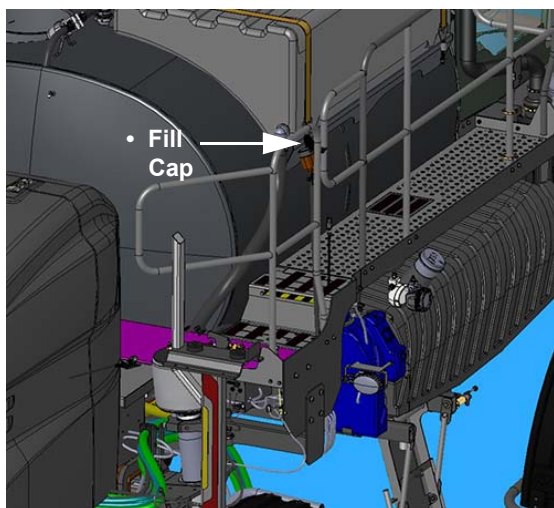

Foam Marker Reservoir Fill
(Located on the rear right-hand handrail)
-Typical View

2. Fill reservoir to desired level with foam concentrate.
3. Close fill cap when finished.

Foam Marker Operation

1. Ensure there is adequate amount of fresh water in the rinse tank.
2. Locate the Foam Marker Switch (located on the side console).
 - Press Foam Marker Switch in the UP position if foam application is desired from the Left Foam Drop.
 - Press Foam Marker Switch in the DOWN position if foam application is desired from the Right Foam Drop.
 - Return Foam Marker Switch to the MID (Off) position if no foam is desired.



Foam Marker Switch
(Located on the side console)
-Typical View

3. Observe system pressure indicated on the Air Pressure Gauge (located on the Foam Marker Control Box beneath platform on rear right-hand side of machine).

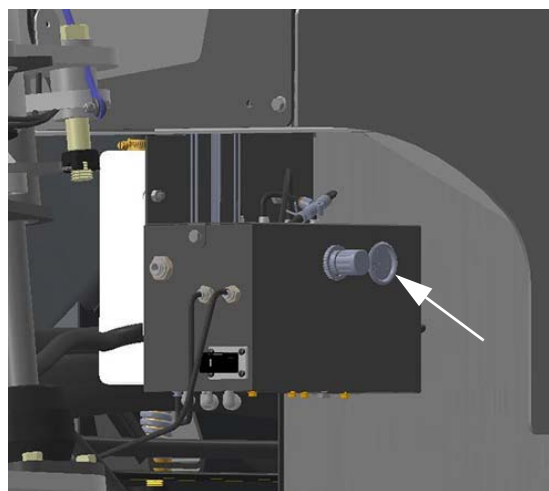

Air Pressure Gauge
(Located on the Foam Marker Control Box)
-Typical View

Foam Marker Control Box

The Foam Marker Control Box is located beneath the platform on the rear right-hand side of machine. The box includes the air pressure regulator, air pressure gauge, manifold block, concentrate pump, and water pump.

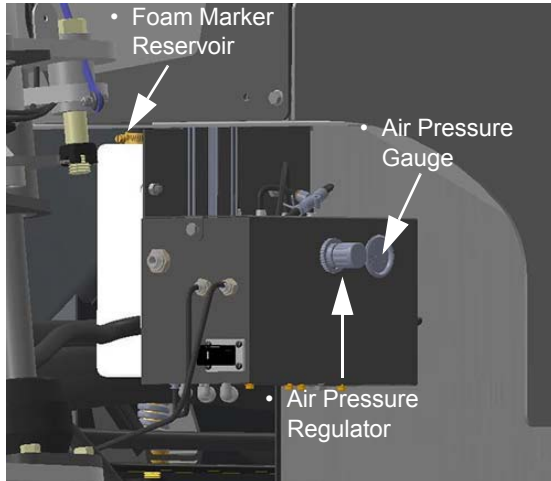

Foam Marker Control Box
(Located beneath platform on
rear right-hand side of machine)
-Typical View

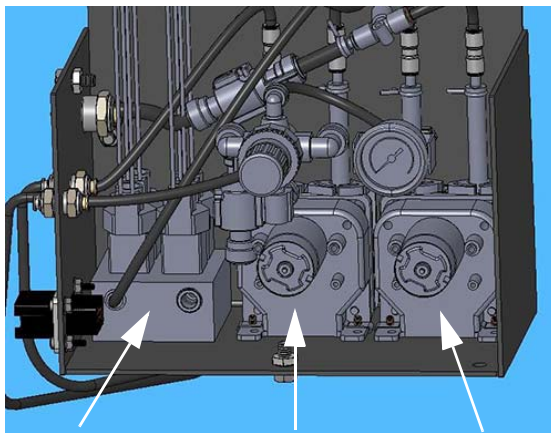

- Manifold Block
- Concentrate Pump
- Water Pump

Foam Marker Control Box
(Interior view)

NOTE: System pressure is displayed on the Air Pressure Gauge next to the Air Pressure Regulator.

- Push the Air Pressure Regulator IN when finished adjusting pressure.

Pressure Relief Valve

A Pressure Relief Valve is located on the back side of the Air Pressure Regulator to relieve excess pressure, if necessary.

- Pull the Pressure Relief Pull Ring OUT to open the valve and relieve system pressure.

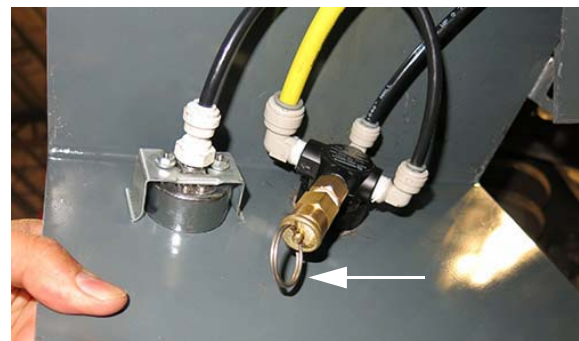

Pressure Relief Pull Ring
(Located on the back side
of the foam pressure regulator)
-Typical View

Foam Marker Frequency and Concentration Settings

Foam Marker frequency and concentration levels are adjusted through the Machine Display. Refer to “Machine Display” in the *Cab Section* elsewhere in this manual for further information.

Pressure Adjustment

Air pressure may be adjusted by operating the Air Pressure Regulator (located on the Foam Marker Control Box). Regulator air input comes from the air tank on the machine.

- Pull the Air Pressure Regulator OUT and rotate the dial in the “counter-clockwise” position to decrease pressure, or “clockwise” to increase pressure.

Foam Drop Configurations

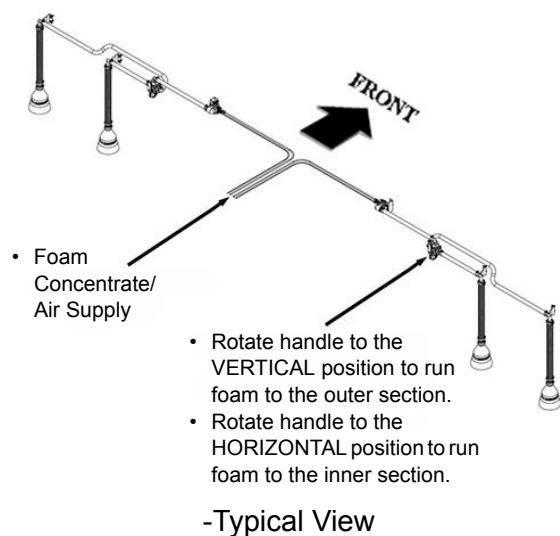

CAUTION

Wear the appropriate clothing and Personal Protective Equipment (PPE) when working with agricultural chemicals. Do not store chemical-soaked clothing inside the cab.

The direct Modular Injection System can be ordered and installed during production or aftermarket on STS machines. The system is offered in the following configurations:

- **One Chemical Tank/One Injection Pump**
- **Two Chemical Tanks/Two Injection Pumps**

NOTE: Chemical Tank Capacity = 55 gallons (208 L)/each.

This system allows the operator to quickly change from one chemical to another without rinsing the main tank in between. Chemical application rate can also be adjusted by concentration variation, which improves application efficiency.

The Modular Injection System accurately injects concentrated chemical, where it is then mixed with water (stored in the main tank) just prior to being applied. Therefore, there is no need to pre-mix chemicals beforehand. There is also no need to dispose of any remaining chemical mixture at the end of use, as unused chemical may remain stored in the chemical tank(s).

The concentrated chemical is extracted from the chemical tank, where it is then sent to the in-line suction strainer, and then routed to the injection pump. From there it is sent to the flow indicator (mounted on the outside of cab), and then to the mixer assembly (where the chemical is mixed with water). From the mixer assembly, the solution is then applied through the spray booms.

The following information refers to components of the Modular Injection System and is not intended to replace the manufacturer's operating instructions.

MODULAR INJECTION SYSTEM

-If Equipped

CAUTION

Agricultural chemicals can be dangerous. Improper selection or use can injure persons, animals, plants, soils or other property.

TO AVOID INJURY

1. Select the right chemical for the job.
2. Handle and apply it with care. Follow instructions issued by the chemical manufacturer.

N203265

Modular Injection System Components

- (A) - Main Tank
- (B) - Chemical Tank(s)
- (C) - Injection Pump(s)
- (D) - Outlet Selector Valve(s)
- (E) - Inlet Selector Valve(s)
- (F) - In-Line Suction Strainer(s)
- (G) - Tank Drain Valve(s) - Upper
- (H) - Tank Drain Valve(s) - Lower
- (I) - Removable Drain Hose
- (J) - Flow Indicator(s)
- (K) - Mixer Assembly

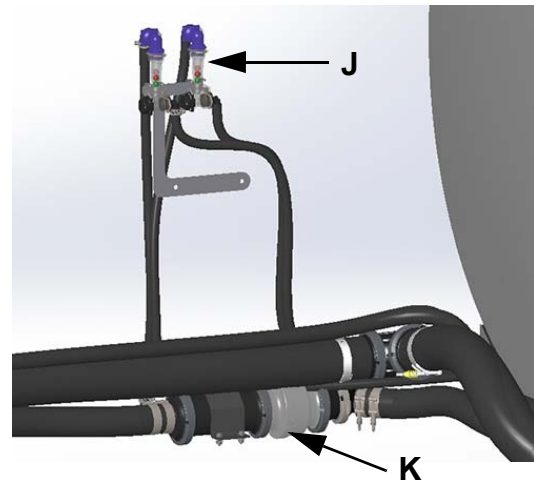
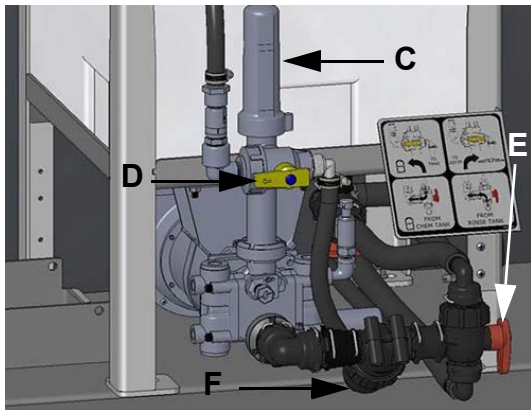
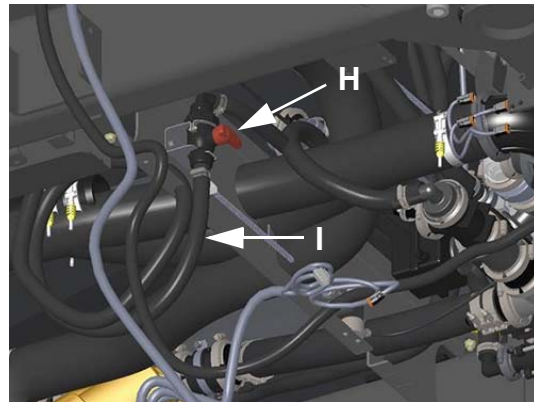
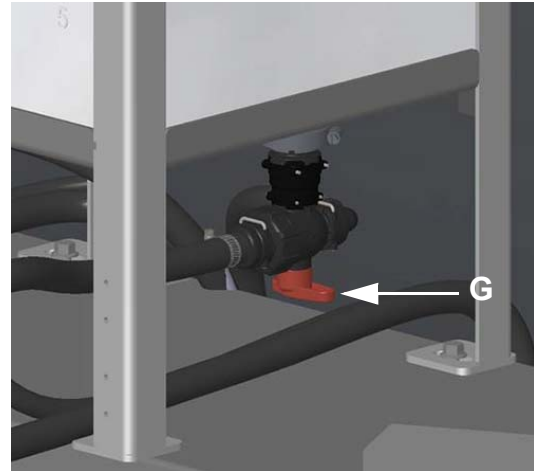
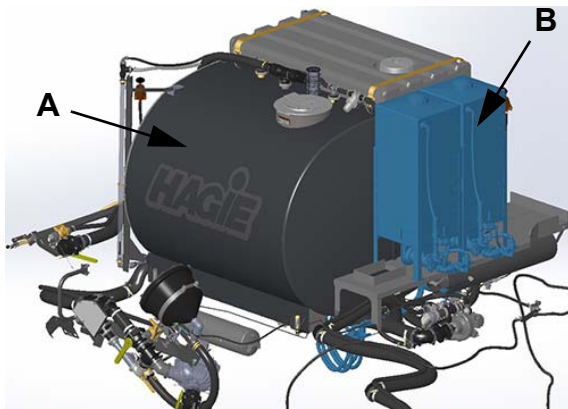

3-Way Valve Handle Flow Positions

Refer to the following illustration to determine correct valve handle orientation when operating the various 3-way valves with this system.

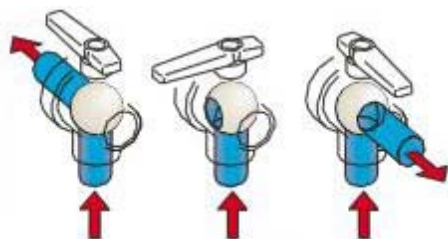

Filling the Chemical Tank(s)

1. Ensure the Tank Drain Valves (upper and lower) are in the OFF (Closed) position.
2. Remove the Fill Port Lid (located on top of the chemical tank) and set aside.



Fill Port Lid
(Located on the top of chemical tank)
-Typical View

3. Pour product through fill port and fill chemical tank to desired level.
4. Reinstall the Fill Port Lid.

Getting Started

NOTICE

Never attempt to operate the Modular Injection System without solution in the tank(s). Failure to comply may result in equipment damage and will void the warranty.

NOTE: Ensure the Master Spray Switch (located on the Hydrostatic Drive Control Handle) is in the OFF position before activating the Solution Pump Switch or the Boom Solution Valve Switches, unless you are ready to begin spray application.

1. Calibrate the Spray System Console (refer to the manufacturer's operation manual for calibration instructions).
2. Ensure there is adequate amount of solution in the chemical tank(s) and water in the main tank.
3. Rotate the Outlet Selector Valve(s) (located on the front of injection pump(s)) to the "TO BOOM" position.

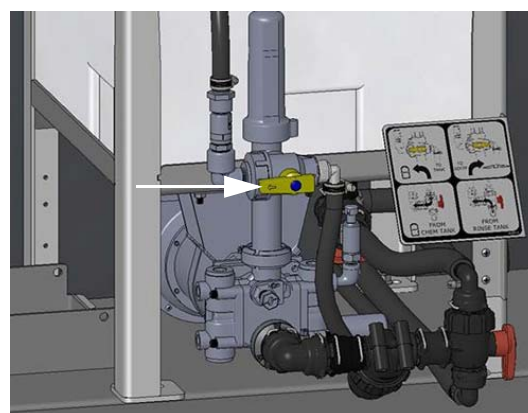

Outlet Selector Valve(s)
(Located on the front of injection pump(s))
-Typical View

* 1-tank/1-pump configuration show

NOTE: Refer to the provided label for valve handle orientation. See following illustration.

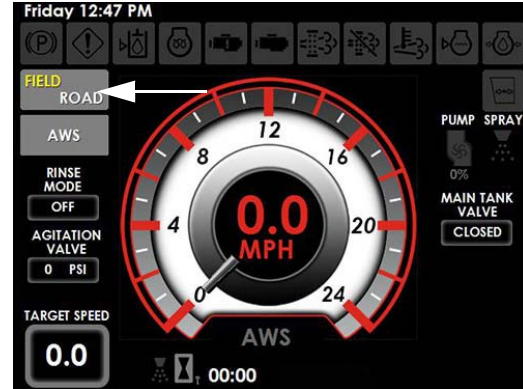
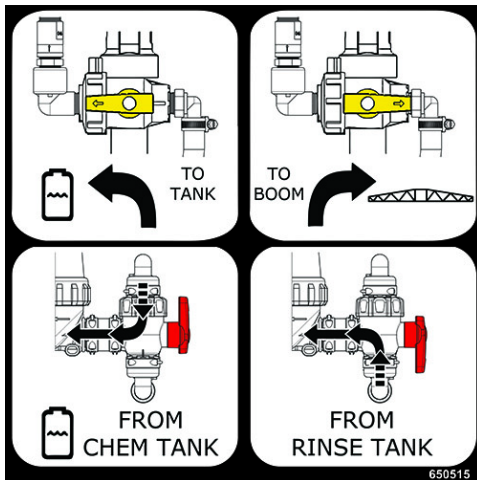

Field/Road Button
(Located on the
Machine Display Home Page)

- Rotate the Inlet Selector Valve(s) (located near the bottom right-hand side of chemical tank(s)) to the “FROM CHEM TANK” position.

NOTE: The selected drive state will illuminate.

- Position boom to desired position.
- Press the Main Tank Valve Switch (located on the side console) in the UP (Open) position.

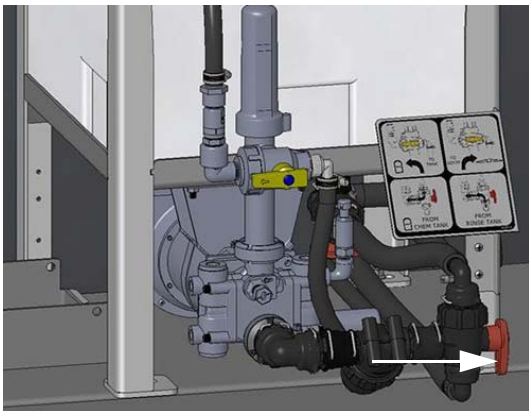

Inlet Selector Valve(s)
(Located near the bottom
right-hand side of chemical tank(s))
-Typical View

* 1-tank/1-pump configuration show



Main Tank Valve Switch
(Located on the side console)
-Typical View

- Engage the parking brake.
- Start the engine.
- Press the Field/Road Button (located on the Machine Display Home Page) and change the machine’s drive state to FIELD.

NOTE: Main Tank Valve status (OPEN or CLOSED) is displayed on the Machine Display Home Page (Field Mode).

NOTE: The drive state of the machine cannot be changed unless the Hydrostatic Drive Control Handle is in the NEUTRAL position (and machine speed is less than 0.5 mph/ 0.8 km/h).



Main Tank Valve Status Indicator
(Located on the Machine Display
Home Page - Field Mode)



Rate Control and
Pump Speed/Rate Switches
(Located on the side console)
-Typical View

10. Press desired Rate Control Switch
(located on the side console).

- Press ENABLE to allow the rate controller to control application rate.
- Press MAN (Manual) to control application rate from the section keypad.
- Press ENABLE and MAN to enable manual rate control through the rate controller.

NOTE: When "MAN" is selected, press the Pump Speed/Rate Switches (located on the side console) to increase (+) or decrease (-) application rate. Current solution pump speed is displayed below the Solution Pump Indicator (located on the Machine Display Home Page - Field Mode).

NOTE: Increasing or decreasing pump speed will change the application rate through the rate controller.

11. Press the Solution Pump Switch (located on the side console) in the UP (On) position.

NOTICE

Do not allow the Solution Pump to run continuously while the Boom Solution Valve Switches are off. Failure to comply will generate overheating, causing severe pump damage and will void the warranty.



Solution Pump Switch
(Located on the side console)
-Typical View

- Turn the Master Spray Switch (located on the Hydrostatic Drive Control Handle) ON.



Master Spray Switch
(Located on the Hydrostatic Drive Control Handle)
-Typical View

NOTE: When the Master Spray Switch is ON, a Master Spray Indicator (located on the Machine Display Home Page - Field Mode) will illuminate.



Master Spray Indicator
(Located on the Machine Display Home Page - Field Mode)

- Press the individual Boom Solution Valve Switches (located on the side console) to the ON (non-illuminated) position.

NOTE: Each Boom Solution Valve Switch is equipped with an indicator light and will illuminate when the corresponding Boom Solution Valve is OFF.



Boom Solution Valve Switches
(Located on the side console)
-Typical View

- Slowly move the Hydrostatic Drive Control Handle forward to obtain desired ground speed.
- Frequently observe the pressure gauge. If the pressure drops to zero or spray pattern deteriorates, turn OFF the Master Spray, Solution Pump Switch, and Main Tank Valve Switch until solution is refilled.

Injection Pump Calibration

- Calibrate the Injection Pump(s) (located near the bottom of chemical tank(s)).

NOTE: Refer to the Raven manufacturer's operation manual for information on injection pump calibration.

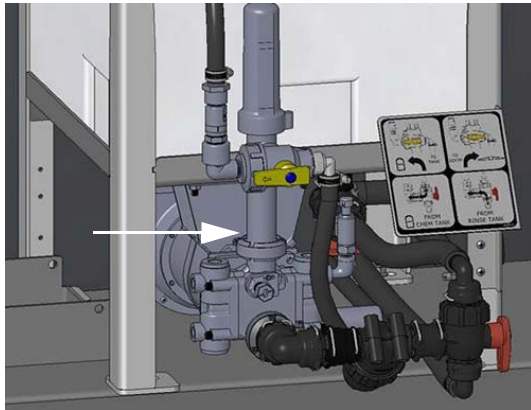

Injection Pump(s)
(Located near the bottom
of chemical tank(s))
-Typical View

* 1-tank/1-pump configuration shown

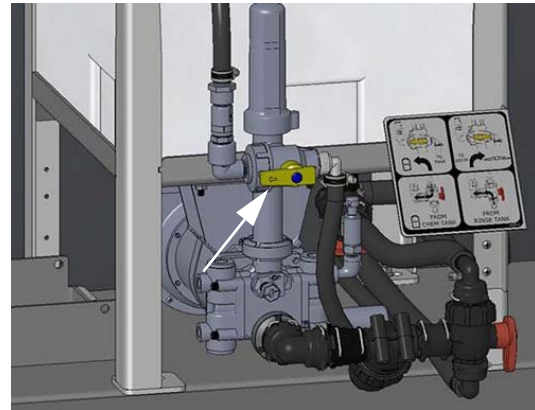

Outlet Selector Valve(s)
(Located on the front of injection pump(s))
-Typical View

* 1-tank/1-pump configuration shown

2. Rotate the Inlet Selector Valve(s) (located near the bottom right-hand side of chemical tank(s)) to the “FROM CHEM TANK” position.

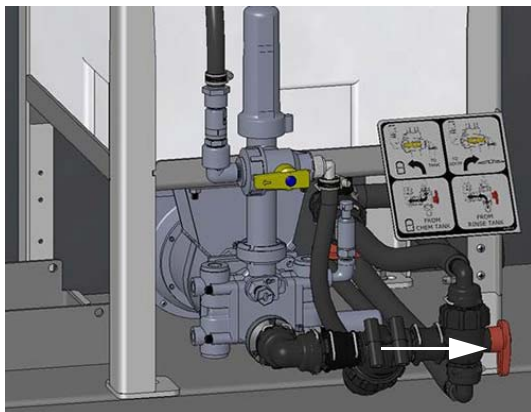

Inlet Selector Valve(s)
(Located near the bottom
right-hand side of chemical tank(s))
-Typical View

* 1-tank/1-pump configuration shown

NOTE: Refer to the provided label for valve handle orientation. See following illustration.

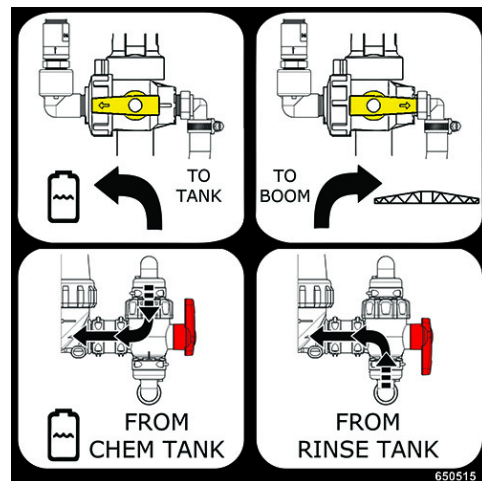

3. Rotate the Outlet Selector Valve(s) (located on the front of injection pump(s)) to the “TO TANK” position. This will allow the chemical to divert back to the tank rather than the booms during the calibration process.

4. When pump calibration is complete, rotate the Outlet Selector Valve(s) to the “TO BOOM” position to send chemical to the Mixer Assembly.

In-Line Suction Strainers

(80-Mesh Strainer Screen)

⚠ CAUTION

Before removing the in-line suction strainer(s), ensure the Inlet Selector Valve(s) is in the OFF (closed) position. Failure to comply may result in chemical contact.

An In-Line Suction Strainer (located in front of injection pump(s)) is provided to reduce the possibility of debris from contaminating the system. With the Inlet Selector Valve(s) (located near the bottom right-hand side of chemical tank(s)) in the OFF (closed) position, remove cap and clean strainer screen periodically to ensure adequate flow.

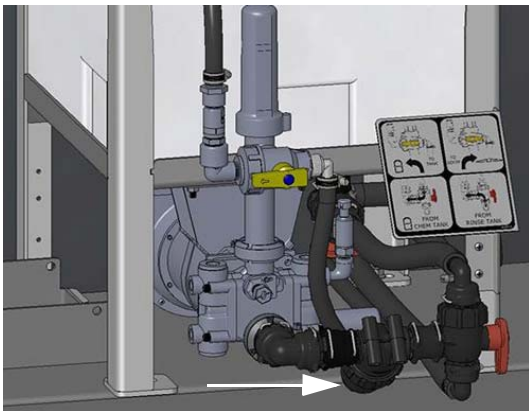

In-Line Suction Strainer(s)
(Located in front of injection pump(s))
-Typical View

* 1-tank/1-pump configuration shown

Flow Indicators

NOTICE

Flow Indicators are not provided as a means to determine an accurate measurement of flow. It is the responsibility of the operator to calibrate the injection pump(s) and choose the correct indicator ball for each product.

Flow Indicators (one per injection pump) are visible from inside the cab and allow the operator to monitor solution flow at all times, as well as ensure the injection pump is operating correctly and what product is flowing.

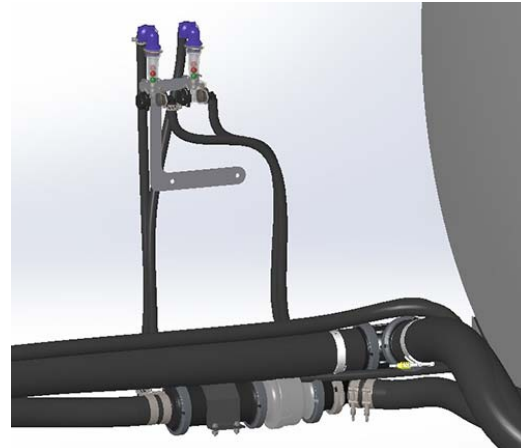

Flow Indicators
(Located on the exterior
right-hand side of cab)
-Typical View

* 2-pump configuration shown

Rinsing the Supply Lines and Injection Pump(s)

If chemical remains in the tank(s) at the end of the day, it is recommended to rinse chemical from the supply lines and injection pump(s). To accomplish this:

1. Rotate the Inlet Selector Valve(s) (located near the bottom right-hand side of chemical tank(s)) to the "FROM RINSE TANK" position to rinse the Injec-

tion Pump(s).
This will allow fresh water from the rinse tank to flow through and flush the lines and pump(s).

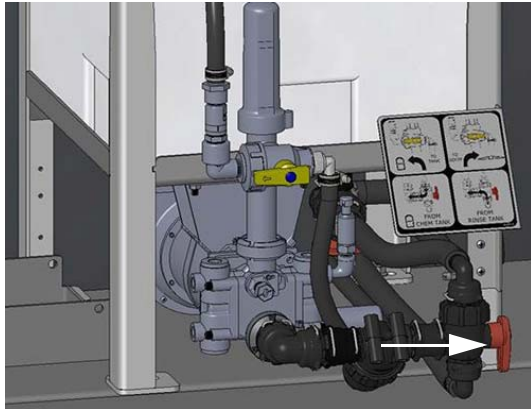

Inlet Selector Valve(s)
(Located near the bottom right-hand side of chemical tank(s))
-Typical View
** 1-tank/1-pump configuration shown*

NOTE: Refer to the provided label for valve handle orientation. See following illustration.

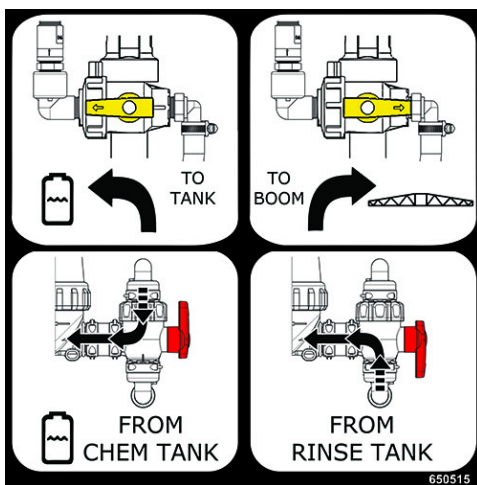

2. Run the Injection Pump(s) with the Outlet Selector Valve(s) (located on the front of injection pump(s)) in the “TO BOOM” position.

Draining the Chemical Tank(s)

NOTICE

Drain chemicals into an adequately sized and clearly labeled container, ensuring lid is tightly closed.

NOTICE

As a safety feature, upper and lower tank drain valves must both be in the OPEN position to drain the chemical tank(s).

1. Ensure the lower Tank Drain Valve (located beneath platform behind solution tank) is in the CLOSED (Off) position.

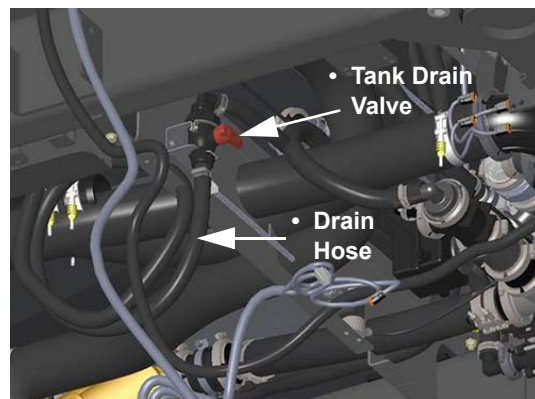

Tank Drain Valve (Lower)/Drain Hose
(Located beneath platform behind solution tank)
-Typical View

** 1-tank/1-pump configuration shown*

2. Place the end of the corresponding Drain Hose into a suitable container.
3. Rotate the upper Tank Drain Valve (located beneath the chemical tank that you are draining) to the OPEN (On) position (away from injection pump).

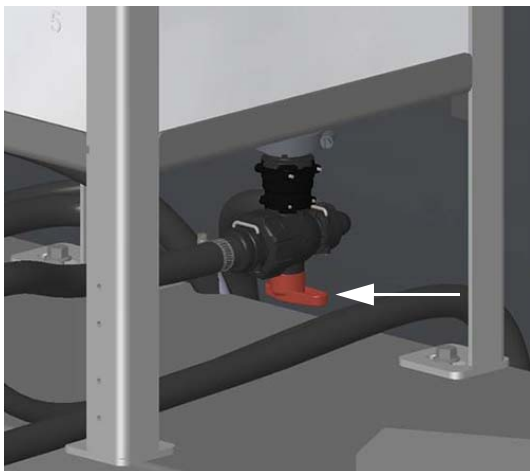

Tank Drain Valve (Upper)
 (Located beneath chemical tank)
 -Typical View

* Valve shown in OPEN position

4. Rotate the lower Tank Drain Valve (located beneath platform behind solution tank) to the OPEN (On) position to drain chemical.
5. **When finished draining tank**, rotate the lower Tank Drain Valve to the CLOSED (Off) position.
6. Rotate the upper Tank Drain Valve to the CLOSED (Off) position (perpendicular to valve body).
7. Remove Drain Hose from collection container and place back into stored position.
8. Repeat steps to drain additional chemical tank - *if equipped* (using the corresponding upper and lower tank drain valves).

Further Information

Refer to the Raven manufacturer's operation manual for complete operating and calibration instructions, troubleshooting tips, safety precautions, and maintenance information.

APPLICATION

It is important to apply chemicals as recommended by the manufacturer. In order to do so, the spray system console must be properly calibrated.

NOTE: Refer to the spray system console manufacturer's operation manual for calibration instructions.

Determine the speed in which the sprayer will travel when applying chemicals. To select the best speed, consider the lay of the land, condition of the soil, type of crop, height of crop, etc.

Remember that the performance of the nozzles (spray tips) and spray system are dependent on the performance of the operator. If the spray system is operated within set parameters of the nozzle type and spray system console, you will see greater success with your application. Operating the machine one or two miles per hour (1.6 to 3.2 km/h) faster or slower than intended can greatly change the pressure and droplet size.

Select nozzle spacing (distance between each nozzle on the spray boom) that is best suited for the intended spray application. For recommendation in determining nozzle spacing and height of the boom, visit www.teejet.com for further information.

There are various types and sizes of nozzles. Select and install the appropriate nozzle best suited for the intended spray application. The type of nozzle will depend on the product being applied and the type of crop that it is being used on. The size of nozzles selected will be based on the speed in which the machine will travel, nozzle spacing, desired droplet size, and the number of gallons per acre (GPA)/liters per hectare (l/ha) that will be applied.

Nozzle Selection

There are several things to consider when selecting the correct nozzle type for the intended spray application. Whatever your personal preference is, ensure that the nozzle complies with the chemical manufacturer's standards for spray control and also any environmental standards for your region.



NOTE: Certain regions may have restrictions on drift control.

Once you have selected the type of nozzle, you must choose the size of the nozzle. There are three main things to consider when choosing a nozzle size:

1. Recommendation of GPA (l/ha).
2. The speed in which you intend to travel when applying chemical and nozzle spacing (distance between nozzles).
3. Spray Tip size (refer to the following example on how to select a proper tip size).

The following Application Rate Chart provides tabulations based on spraying water. When spraying liquids other than water, you will need to use a conversion factor to configure the appropriate application rates.

Example of how to choose the proper nozzle:

Joe is spraying 28% nitrogen. The chemical manufacturer recommends that the chemical be applied at 20 gallons per acre (GPA)/187 liters per hectare (l/ha). Joe knows that he can run his sprayer at 10 mph (16 km/h) across the field. He has 20-inch (50 cm) nozzle spacing on his booms. Joe has narrowed his tip search to flat spray tips.

Use the following conversion formula:

- **20 GPA (187 l/ha) (liquid other than water) x 1.13 (conversion factor) = 22.6 GPA (211.3 l/ha) (water).**

Joe determined that he needs an application rate of 22.6 GPA (211.3 l/ha) to select the correct nozzle to apply 28% nitrogen at 20 GPA (187 l/ha).

To determine which nozzle is better for his intended use, Joe needs to figure out the gallons per minute (GPM)/liters per minute (l/min) each nozzle needs to spray.

| | |
|--------------|---|
| GPM = | $\frac{\text{GPA} \times \text{MPH} \times \text{Nozzle Spacing}}{5940 \text{ (Constant)}}$ |
|--------------|---|

| | |
|----------------|--|
| l/min = | $\frac{\text{l/ha} \times \text{km/h} \times \text{Nozzle Spacing}}{60,000}$ |
|----------------|--|

Examples:

| | | | |
|--------------|---|---------------|--------------------------------|
| GPM = | $\frac{22.6 \times 10 \times 20}{5940}$ | = 4520 | = 0.76 GPM (per nozzle) |
| | 5940 | 5940 | |

| | | | |
|----------------|--|-----------------|----------------------------------|
| l/min = | $\frac{211.3 \times 16 \times 50}{60,000}$ | = 169040 | = 2.82 l/min (per nozzle) |
| | 60,000 | 60,000 | |

English to Metric Conversion

- Gallons per Acre (GPA) x 9.354 = Liters per Hectare (l/ha)
- Gallons per Minute (GPM) x 3.785 = Liters per Minute (l/min)

Metric to English Conversion

- Liters per Hectare (l/ha) x .1069 = Gallons per Acre (GPA)
- Liters per Minute (l/min) x .26 = Gallons per Minute (GPM)

NOTE: Always double check your application rates. The following tabulations are based on spraying water at 70° F./21° C.



| Standard Application Rate Chart | | | | | | | | | | | | |
|---------------------------------|-----------------------|---------------------|--------------------------|---|-------|-------|--------|--------|--------|--------|--------|--------|
| | | | | Gallons per Acre (GPA) - 15" Nozzle Spacing | | | | | | | | |
| Tip Cap. | Liquid Pressure (PSI) | Cap. 1 Nozzle (GPM) | Cap. 1 Nozzle (Oz./Min.) | 4 mph | 6 mph | 8 mph | 10 mph | 12 mph | 14 mph | 16 mph | 18 mph | 20 mph |
| 01 | 15 | 0.061 | 7.8 | 6.0 | 4.0 | 3.0 | 2.4 | 2.0 | 1.7 | 1.5 | 1.3 | 1.2 |
| | 20 | 0.071 | 9.1 | 7.0 | 4.7 | 3.5 | 2.8 | 2.3 | 2.0 | 1.8 | 1.6 | 1.4 |
| | 30 | 0.087 | 11 | 8.6 | 5.7 | 4.3 | 3.4 | 2.9 | 2.5 | 2.2 | 1.9 | 1.7 |
| | 40 | 0.10 | 13 | 9.9 | 6.6 | 5.0 | 4.0 | 3.3 | 2.8 | 2.5 | 2.2 | 2.0 |
| | 50 | 0.11 | 14 | 10.9 | 7.3 | 5.4 | 4.4 | 3.6 | 3.1 | 2.7 | 2.4 | 2.2 |
| | 60 | 0.12 | 15 | 11.9 | 7.9 | 5.9 | 4.8 | 4.0 | 3.4 | 3.0 | 2.6 | 2.4 |
| | 75 | 0.14 | 18 | 13.9 | 9.2 | 6.9 | 5.5 | 4.6 | 4.0 | 3.5 | 3.1 | 2.8 |
| | 90 | 0.15 | 19 | 14.9 | 9.9 | 7.4 | 5.9 | 5.0 | 4.2 | 3.7 | 3.3 | 3.0 |
| 015 | 15 | 0.092 | 12 | 9.1 | 6.1 | 4.6 | 3.6 | 3.0 | 2.6 | 2.3 | 2.0 | 1.8 |
| | 20 | 0.11 | 14 | 10.9 | 7.3 | 5.4 | 4.4 | 3.6 | 3.1 | 2.7 | 2.4 | 2.2 |
| | 30 | 0.13 | 17 | 12.9 | 8.6 | 6.4 | 5.1 | 4.3 | 3.7 | 3.2 | 2.9 | 2.6 |
| | 40 | 0.15 | 19 | 14.9 | 9.9 | 7.4 | 5.9 | 5.0 | 4.2 | 3.7 | 3.3 | 3.0 |
| | 50 | 0.17 | 22 | 16.8 | 11.2 | 8.4 | 6.7 | 5.6 | 4.8 | 4.2 | 3.7 | 3.4 |
| | 60 | 0.18 | 23 | 17.8 | 11.9 | 8.9 | 7.1 | 5.9 | 5.1 | 4.5 | 4.0 | 3.6 |
| | 75 | 0.21 | 27 | 21 | 13.9 | 10.4 | 8.3 | 6.9 | 5.9 | 5.2 | 4.6 | 4.2 |
| | 90 | 0.23 | 29 | 23 | 15.2 | 11.4 | 9.1 | 7.6 | 6.5 | 5.7 | 5.1 | 4.6 |
| 02 | 15 | 0.12 | 15 | 11.9 | 7.9 | 5.9 | 4.8 | 4.0 | 3.4 | 3.0 | 2.6 | 2.4 |
| | 20 | 0.14 | 18 | 13.9 | 9.2 | 6.9 | 5.5 | 4.6 | 4.0 | 3.5 | 3.1 | 2.8 |
| | 30 | 0.17 | 22 | 16.8 | 11.2 | 8.4 | 6.7 | 5.6 | 4.8 | 4.2 | 3.7 | 3.4 |
| | 40 | 0.20 | 26 | 19.8 | 13.2 | 9.9 | 7.9 | 6.6 | 5.7 | 5.0 | 4.4 | 4.0 |
| | 50 | 0.22 | 28 | 22 | 14.5 | 10.9 | 8.7 | 7.3 | 6.2 | 5.4 | 4.8 | 4.4 |
| | 60 | 0.24 | 31 | 24 | 15.8 | 11.9 | 9.5 | 7.9 | 6.8 | 5.9 | 5.3 | 4.8 |
| | 75 | 0.27 | 35 | 27 | 17.8 | 13.4 | 10.7 | 8.9 | 7.6 | 6.7 | 5.9 | 5.3 |
| | 90 | 0.30 | 38 | 30 | 19.8 | 14.9 | 11.9 | 9.9 | 8.5 | 7.4 | 6.6 | 5.9 |
| 025 | 15 | 0.15 | 19 | 14.9 | 9.9 | 7.4 | 5.9 | 5.0 | 4.2 | 3.7 | 3.3 | 3.0 |
| | 20 | 0.18 | 23 | 17.8 | 11.9 | 8.9 | 7.1 | 5.9 | 5.1 | 4.5 | 4.0 | 3.6 |
| | 30 | 0.22 | 28 | 22 | 14.5 | 10.9 | 8.7 | 7.3 | 6.2 | 5.4 | 4.8 | 4.4 |
| | 40 | 0.25 | 32 | 25 | 16.5 | 12.4 | 9.9 | 8.3 | 7.1 | 6.2 | 5.5 | 5.0 |
| | 50 | 0.28 | 36 | 28 | 18.5 | 13.9 | 11.1 | 9.2 | 7.9 | 6.9 | 6.2 | 5.5 |
| | 60 | 0.31 | 40 | 31 | 20 | 15.3 | 12.3 | 10.2 | 8.8 | 7.7 | 6.8 | 6.1 |
| | 75 | 0.34 | 44 | 34 | 22 | 16.8 | 13.5 | 11.2 | 9.6 | 8.4 | 7.5 | 6.7 |
| | 90 | 0.38 | 49 | 38 | 25 | 18.8 | 15.0 | 12.5 | 10.7 | 9.4 | 8.4 | 7.5 |



SECTION 7 -
SPRAY SYSTEMS

| | | | | | | | | | | | | |
|----|----|------|-----|------|------|------|------|------|------|------|------|------|
| 03 | 15 | 0.18 | 23 | 17.8 | 11.9 | 8.9 | 7.1 | 5.9 | 5.1 | 4.5 | 4.0 | 3.6 |
| | 20 | 0.21 | 27 | 21 | 13.9 | 10.4 | 8.3 | 6.9 | 5.9 | 5.2 | 4.6 | 4.2 |
| | 30 | 0.26 | 33 | 26 | 17.2 | 12.9 | 10.3 | 8.6 | 7.4 | 6.4 | 5.7 | 5.1 |
| | 40 | 0.30 | 38 | 30 | 19.8 | 14.9 | 11.9 | 9.9 | 8.5 | 7.4 | 6.6 | 5.9 |
| | 50 | 0.34 | 44 | 34 | 22 | 16.8 | 13.5 | 11.2 | 9.6 | 8.4 | 7.5 | 6.7 |
| | 60 | 0.37 | 47 | 37 | 24 | 18.3 | 14.7 | 12.2 | 10.5 | 9.2 | 8.1 | 7.3 |
| | 75 | 0.41 | 52 | 41 | 27 | 20 | 16.2 | 13.5 | 11.6 | 10.1 | 9.0 | 8.1 |
| | 90 | 0.45 | 58 | 45 | 30 | 22 | 17.8 | 14.9 | 12.7 | 11.1 | 9.9 | 8.9 |
| 04 | 15 | 0.24 | 31 | 24 | 15.8 | 11.9 | 9.5 | 7.9 | 6.8 | 5.9 | 5.3 | 4.8 |
| | 20 | 0.28 | 36 | 28 | 18.5 | 13.9 | 11.1 | 9.2 | 7.9 | 6.9 | 6.2 | 5.5 |
| | 30 | 0.35 | 45 | 35 | 23 | 17.3 | 13.9 | 11.6 | 9.9 | 8.7 | 7.7 | 6.9 |
| | 40 | 0.40 | 51 | 40 | 26 | 19.8 | 15.8 | 13.2 | 11.3 | 9.9 | 8.8 | 7.9 |
| | 50 | 0.45 | 58 | 45 | 30 | 22 | 17.8 | 14.9 | 12.7 | 11.1 | 9.9 | 8.9 |
| | 60 | 0.49 | 63 | 49 | 32 | 24 | 19.4 | 16.2 | 13.9 | 12.1 | 10.8 | 9.7 |
| | 75 | 0.55 | 70 | 54 | 36 | 27 | 22 | 18.2 | 15.6 | 13.6 | 12.1 | 10.9 |
| | 90 | 0.60 | 77 | 59 | 40 | 30 | 24 | 19.8 | 17.0 | 14.9 | 13.2 | 11.9 |
| 05 | 15 | 0.31 | 40 | 31 | 20 | 15.3 | 12.3 | 10.2 | 8.8 | 7.7 | 6.8 | 6.1 |
| | 20 | 0.35 | 45 | 35 | 23 | 17.3 | 13.9 | 11.6 | 9.9 | 8.7 | 7.7 | 6.9 |
| | 30 | 0.43 | 55 | 43 | 28 | 21 | 17.0 | 14.2 | 12.2 | 10.6 | 9.5 | 8.5 |
| | 40 | 0.50 | 64 | 50 | 33 | 25 | 19.8 | 16.5 | 14.1 | 12.4 | 11.0 | 9.9 |
| | 50 | 0.56 | 72 | 55 | 37 | 28 | 22 | 18.5 | 15.8 | 13.9 | 12.3 | 11.1 |
| | 60 | 0.61 | 78 | 60 | 40 | 30 | 24 | 20 | 17.3 | 15.1 | 13.4 | 12.1 |
| | 75 | 0.68 | 87 | 67 | 45 | 34 | 27 | 22 | 19.2 | 16.8 | 15.0 | 13.5 |
| | 90 | 0.75 | 96 | 74 | 50 | 37 | 30 | 25 | 21 | 18.6 | 16.5 | 14.9 |
| 06 | 15 | 0.37 | 47 | 37 | 24 | 18.3 | 14.7 | 12.2 | 10.5 | 9.2 | 8.1 | 7.3 |
| | 20 | 0.42 | 54 | 42 | 28 | 21 | 16.6 | 13.9 | 11.9 | 10.4 | 9.2 | 8.3 |
| | 30 | 0.52 | 67 | 51 | 34 | 26 | 21 | 17.2 | 14.7 | 12.9 | 11.4 | 10.3 |
| | 40 | 0.60 | 77 | 59 | 40 | 30 | 24 | 19.8 | 17.0 | 14.9 | 13.2 | 11.9 |
| | 50 | 0.67 | 86 | 66 | 44 | 33 | 27 | 22 | 19.0 | 16.6 | 14.7 | 13.3 |
| | 60 | 0.73 | 93 | 72 | 48 | 36 | 29 | 24 | 21 | 18.1 | 16.1 | 14.5 |
| | 75 | 0.82 | 105 | 81 | 54 | 41 | 32 | 27 | 23 | 20 | 18.0 | 16.2 |
| | 90 | 0.90 | 115 | 89 | 59 | 45 | 36 | 30 | 25 | 22 | 19.8 | 17.8 |
| 08 | 15 | 0.49 | 63 | 49 | 32 | 24 | 19.4 | 16.2 | 13.9 | 12.1 | 10.8 | 9.7 |
| | 20 | 0.57 | 73 | 56 | 38 | 28 | 23 | 18.8 | 16.1 | 14.1 | 12.5 | 11.3 |
| | 30 | 0.69 | 88 | 68 | 46 | 34 | 27 | 23 | 19.5 | 17.1 | 15.2 | 13.7 |
| | 40 | 0.80 | 102 | 79 | 53 | 40 | 32 | 26 | 23 | 19.8 | 17.6 | 15.8 |
| | 50 | 0.89 | 114 | 88 | 59 | 44 | 35 | 29 | 25 | 22 | 19.6 | 17.6 |
| | 60 | 0.98 | 125 | 97 | 65 | 49 | 39 | 32 | 28 | 24 | 22 | 19.4 |
| | 75 | 1.10 | 141 | 109 | 73 | 54 | 44 | 36 | 31 | 27 | 24 | 22 |
| | 90 | 1.20 | 154 | 119 | 79 | 59 | 48 | 40 | 34 | 30 | 26 | 24 |
| 10 | 15 | 0.61 | 78 | 60 | 40 | 30 | 24 | 20 | 17.3 | 15.1 | 13.4 | 12.1 |
| | 20 | 0.71 | 91 | 70 | 47 | 35 | 28 | 23 | 20 | 17.6 | 15.6 | 14.1 |
| | 30 | 0.87 | 111 | 86 | 57 | 43 | 34 | 29 | 25 | 22 | 19.1 | 17.2 |
| | 40 | 1.00 | 128 | 99 | 66 | 50 | 40 | 33 | 28 | 25 | 22 | 19.8 |
| | 50 | 1.12 | 143 | 111 | 74 | 55 | 44 | 37 | 32 | 28 | 25 | 22 |
| | 60 | 1.22 | 156 | 121 | 81 | 60 | 48 | 40 | 35 | 30 | 27 | 24 |
| | 75 | 1.37 | 175 | 136 | 90 | 68 | 54 | 45 | 39 | 34 | 30 | 27 |
| | 90 | 1.50 | 192 | 149 | 99 | 74 | 59 | 50 | 42 | 37 | 33 | 30 |
| 15 | 15 | 0.92 | 118 | 91 | 61 | 46 | 36 | 30 | 26 | 23 | 20 | 18.2 |
| | 20 | 1.06 | 136 | 105 | 70 | 52 | 42 | 35 | 30 | 26 | 23 | 21 |
| | 30 | 1.30 | 166 | 129 | 86 | 64 | 51 | 43 | 37 | 32 | 29 | 26 |
| | 40 | 1.50 | 192 | 149 | 99 | 74 | 59 | 50 | 42 | 37 | 33 | 30 |
| | 50 | 1.68 | 215 | 166 | 111 | 83 | 67 | 55 | 48 | 42 | 37 | 33 |
| | 60 | 1.84 | 236 | 182 | 121 | 91 | 73 | 61 | 52 | 46 | 40 | 36 |
| | 75 | 2.05 | 262 | 203 | 135 | 101 | 81 | 68 | 58 | 51 | 45 | 41 |
| | 90 | 2.25 | 288 | 223 | 149 | 111 | 89 | 74 | 64 | 56 | 50 | 45 |

SECTION 7 -
SPRAY SYSTEMS



| | | | | | | | | | | | | |
|----|----|------|-----|-----|-----|-----|-----|----|----|----|----|----|
| 20 | 15 | 1.22 | 156 | 121 | 81 | 60 | 48 | 40 | 35 | 30 | 27 | 24 |
| | 20 | 1.41 | 180 | 140 | 93 | 70 | 56 | 47 | 40 | 35 | 31 | 28 |
| | 30 | 1.73 | 221 | 171 | 114 | 86 | 69 | 57 | 49 | 43 | 38 | 34 |
| | 40 | 2.00 | 256 | 198 | 132 | 99 | 79 | 66 | 57 | 50 | 44 | 40 |
| | 50 | 2.24 | 287 | 222 | 148 | 111 | 89 | 74 | 63 | 55 | 49 | 44 |
| | 60 | 2.45 | 314 | 243 | 162 | 121 | 97 | 81 | 69 | 61 | 54 | 49 |
| | 75 | 2.74 | 351 | 271 | 181 | 136 | 109 | 90 | 78 | 68 | 60 | 54 |
| | 90 | 3.00 | 384 | 297 | 198 | 149 | 119 | 99 | 85 | 74 | 66 | 59 |



| Metric Application Rate Chart | | | | | | | | | | | | | |
|-------------------------------|---------------------|-----------------------|--|--------|--------|---------|---------|---------|---------|---------|---------|---------|---------|
| | | | Liters per Hectare (l/ha) - 40 cm Nozzle Spacing | | | | | | | | | | |
| Tip Cap. | Liquid Press. (Bar) | Cap. 1 Nozzle (l/min) | 4 km/h | 6 km/h | 8 km/h | 10 km/h | 12 km/h | 14 km/h | 16 km/h | 18 km/h | 20 km/h | 25 km/h | 30 km/h |
| 01 | 1.0 | 0.23 | 86.3 | 57.5 | 43.1 | 34.5 | 28.8 | 24.6 | 21.6 | 19.2 | 17.3 | 13.8 | 11.5 |
| | 1.5 | 0.28 | 105 | 70.0 | 52.5 | 42.0 | 35.0 | 30.0 | 26.3 | 23.3 | 21.0 | 16.8 | 14.0 |
| | 2.0 | 0.32 | 120 | 80.0 | 60.0 | 48.0 | 40.0 | 34.3 | 30.0 | 26.7 | 24.0 | 19.2 | 16.0 |
| | 3.0 | 0.39 | 146 | 97.5 | 73.1 | 58.5 | 48.8 | 41.8 | 36.6 | 32.5 | 29.3 | 23.4 | 19.5 |
| | 4.0 | 0.45 | 169 | 113 | 84.4 | 67.5 | 56.3 | 48.2 | 42.2 | 37.5 | 33.8 | 27.0 | 22.5 |
| | 5.0 | 0.50 | 188 | 125 | 93.8 | 75.0 | 62.5 | 53.6 | 46.9 | 41.7 | 37.5 | 30.0 | 25.0 |
| | 6.0 | 0.55 | 206 | 138 | 103 | 82.5 | 68.8 | 58.9 | 51.6 | 45.8 | 41.3 | 33.0 | 27.5 |
| | 7.0 | 0.60 | 225 | 150 | 113 | 90.0 | 75.0 | 64.3 | 56.3 | 50.0 | 45.0 | 36.0 | 30.0 |
| 015 | 1.0 | 0.34 | 128 | 85 | 63.8 | 51.0 | 42.5 | 36.4 | 31.9 | 28.3 | 25.5 | 20.4 | 17.0 |
| | 1.5 | 0.42 | 158 | 105 | 78.8 | 63.0 | 52.5 | 45.0 | 39.4 | 35.0 | 31.5 | 25.2 | 21.0 |
| | 2.0 | 0.48 | 180 | 120 | 90.0 | 72.0 | 60.0 | 51.4 | 45.0 | 40.0 | 36.0 | 28.8 | 24.0 |
| | 3.0 | 0.59 | 221 | 148 | 111 | 88.5 | 73.8 | 63.2 | 55.3 | 49.2 | 44.3 | 35.4 | 29.5 |
| | 4.0 | 0.68 | 255 | 170 | 128 | 102 | 85.0 | 72.9 | 63.8 | 56.7 | 51.0 | 40.8 | 34.0 |
| | 5.0 | 0.76 | 285 | 190 | 143 | 114 | 95.0 | 81.4 | 71.3 | 63.3 | 57.0 | 45.6 | 38.0 |
| | 6.0 | 0.83 | 311 | 208 | 156 | 125 | 104 | 88.9 | 77.8 | 69.2 | 62.3 | 49.8 | 41.5 |
| | 7.0 | 0.90 | 338 | 225 | 169 | 135 | 113 | 96.4 | 84.4 | 75.0 | 67.5 | 54.0 | 45.0 |
| 02 | 1.0 | 0.46 | 173 | 115 | 86.3 | 69.0 | 57.5 | 49.3 | 43.1 | 38.3 | 34.5 | 27.6 | 23.0 |
| | 1.5 | 0.56 | 210 | 140 | 105 | 84.0 | 70.0 | 60.0 | 52.5 | 46.7 | 42.0 | 33.6 | 28.0 |
| | 2.0 | 0.65 | 244 | 163 | 122 | 97.5 | 81.3 | 69.6 | 60.9 | 54.2 | 48.8 | 39.0 | 32.5 |
| | 3.0 | 0.79 | 296 | 198 | 148 | 119 | 98.8 | 84.6 | 74.1 | 65.8 | 59.3 | 47.4 | 39.5 |
| | 4.0 | 0.91 | 341 | 228 | 171 | 137 | 114 | 97.5 | 85.3 | 75.8 | 68.3 | 54.6 | 45.5 |
| | 5.0 | 1.02 | 383 | 255 | 191 | 153 | 128 | 109 | 95.6 | 85.0 | 76.5 | 61.2 | 51.0 |
| | 6.0 | 1.12 | 420 | 280 | 210 | 168 | 140 | 120 | 105 | 93.3 | 84.0 | 67.2 | 56.0 |
| | 7.0 | 1.21 | 454 | 303 | 227 | 182 | 151 | 130 | 113 | 101 | 90.8 | 72.6 | 60.5 |
| 025 | 1.0 | 0.57 | 214 | 143 | 107 | 85.5 | 71.3 | 61.1 | 53.4 | 47.5 | 42.8 | 34.2 | 28.5 |
| | 1.5 | 0.70 | 263 | 175 | 131 | 105 | 87.5 | 75.0 | 65.6 | 58.3 | 52.5 | 42.0 | 35.0 |
| | 2.0 | 0.81 | 304 | 203 | 152 | 122 | 101 | 86.8 | 75.9 | 67.5 | 60.8 | 48.6 | 40.5 |
| | 3.0 | 0.99 | 371 | 248 | 186 | 149 | 124 | 106 | 92.8 | 82.5 | 74.3 | 59.4 | 49.5 |
| | 4.0 | 1.14 | 428 | 285 | 214 | 171 | 143 | 122 | 107 | 95.0 | 85.5 | 68.4 | 57.0 |
| | 5.0 | 1.28 | 480 | 320 | 240 | 192 | 160 | 137 | 120 | 107 | 96.0 | 76.8 | 64.0 |
| | 6.0 | 1.40 | 525 | 350 | 263 | 210 | 175 | 150 | 131 | 117 | 105 | 84.0 | 70.0 |
| | 7.0 | 1.51 | 566 | 378 | 283 | 227 | 189 | 162 | 142 | 126 | 113 | 90.6 | 75.5 |

SECTION 7 –
SPRAY SYSTEMS



| | | | | | | | | | | | | | |
|----|-----|------|------|------|------|------|------|------|------|------|------|------|------|
| 03 | 1.0 | 0.68 | 255 | 170 | 128 | 102 | 85 | 72.9 | 63.8 | 56.7 | 51.0 | 40.8 | 34.0 |
| | 1.5 | 0.83 | 311 | 208 | 156 | 125 | 104 | 88.9 | 77.8 | 69.2 | 62.3 | 49.8 | 41.5 |
| | 2.0 | 0.96 | 360 | 240 | 180 | 144 | 120 | 103 | 90.0 | 80.0 | 72.0 | 57.6 | 48.0 |
| | 3.0 | 1.18 | 443 | 295 | 221 | 177 | 148 | 126 | 111 | 98.3 | 88.5 | 70.8 | 59.0 |
| | 4.0 | 1.36 | 510 | 340 | 255 | 204 | 170 | 146 | 128 | 113 | 102 | 81.6 | 68.0 |
| | 5.0 | 1.52 | 570 | 380 | 285 | 228 | 190 | 163 | 143 | 127 | 114 | 91.2 | 76.0 |
| | 6.0 | 1.67 | 626 | 418 | 313 | 251 | 209 | 179 | 157 | 139 | 125 | 100 | 83.5 |
| | 7.0 | 1.80 | 675 | 450 | 338 | 270 | 225 | 193 | 169 | 150 | 135 | 108 | 90.0 |
| 04 | 1.0 | 0.91 | 341 | 228 | 171 | 137 | 114 | 97.5 | 85.3 | 75.8 | 68.3 | 54.6 | 45.5 |
| | 1.5 | 1.12 | 420 | 280 | 210 | 168 | 140 | 120 | 105 | 93.3 | 84.0 | 67.2 | 56.0 |
| | 2.0 | 1.29 | 484 | 323 | 242 | 194 | 161 | 138 | 121 | 108 | 96.8 | 77.4 | 64.5 |
| | 3.0 | 1.58 | 593 | 395 | 296 | 237 | 198 | 169 | 148 | 132 | 119 | 94.8 | 79.0 |
| | 4.0 | 1.82 | 683 | 455 | 341 | 273 | 228 | 195 | 171 | 152 | 137 | 109 | 91.0 |
| | 5.0 | 2.04 | 765 | 510 | 383 | 306 | 255 | 219 | 191 | 170 | 153 | 122 | 102 |
| | 6.0 | 2.23 | 836 | 558 | 418 | 335 | 279 | 239 | 209 | 186 | 167 | 134 | 112 |
| | 7.0 | 2.41 | 904 | 603 | 452 | 362 | 301 | 258 | 226 | 201 | 181 | 145 | 121 |
| 05 | 1.0 | 1.14 | 428 | 285 | 214 | 171 | 143 | 122 | 107 | 95 | 85.5 | 68.4 | 57.0 |
| | 1.5 | 1.39 | 521 | 348 | 261 | 209 | 174 | 149 | 130 | 116 | 104 | 83.4 | 69.5 |
| | 2.0 | 1.61 | 604 | 403 | 302 | 242 | 201 | 173 | 151 | 134 | 121 | 96.6 | 80.5 |
| | 3.0 | 1.97 | 739 | 493 | 369 | 296 | 246 | 211 | 185 | 164 | 148 | 118 | 98.5 |
| | 4.0 | 2.27 | 851 | 568 | 426 | 341 | 284 | 243 | 213 | 189 | 170 | 136 | 114 |
| | 5.0 | 2.54 | 953 | 635 | 476 | 381 | 318 | 272 | 238 | 212 | 191 | 152 | 127 |
| | 6.0 | 2.79 | 1046 | 698 | 523 | 419 | 349 | 299 | 262 | 233 | 209 | 167 | 140 |
| | 7.0 | 3.01 | 1129 | 753 | 564 | 452 | 376 | 323 | 282 | 251 | 226 | 181 | 151 |
| 06 | 1.0 | 1.37 | 514 | 343 | 257 | 206 | 171 | 147 | 128 | 114 | 103 | 82.2 | 68.5 |
| | 1.5 | 1.68 | 630 | 420 | 315 | 252 | 210 | 180 | 158 | 140 | 126 | 101 | 84.0 |
| | 2.0 | 1.94 | 728 | 485 | 364 | 291 | 243 | 208 | 182 | 162 | 146 | 116 | 97.0 |
| | 3.0 | 2.37 | 889 | 593 | 444 | 356 | 296 | 254 | 222 | 198 | 178 | 142 | 119 |
| | 4.0 | 2.74 | 1028 | 685 | 514 | 411 | 343 | 294 | 257 | 228 | 206 | 164 | 137 |
| | 5.0 | 3.06 | 1148 | 765 | 574 | 459 | 383 | 328 | 287 | 255 | 230 | 184 | 153 |
| | 6.0 | 3.35 | 1256 | 838 | 628 | 503 | 419 | 359 | 314 | 279 | 251 | 201 | 168 |
| | 7.0 | 3.62 | 1358 | 905 | 679 | 543 | 453 | 388 | 339 | 302 | 272 | 217 | 181 |
| 08 | 1.0 | 1.82 | 683 | 455 | 341 | 273 | 228 | 195 | 171 | 152 | 137 | 109 | 91 |
| | 1.5 | 2.23 | 836 | 558 | 418 | 335 | 279 | 239 | 209 | 186 | 167 | 134 | 112 |
| | 2.0 | 2.58 | 968 | 645 | 484 | 387 | 323 | 276 | 242 | 215 | 194 | 155 | 129 |
| | 3.0 | 3.16 | 1185 | 790 | 593 | 474 | 395 | 339 | 296 | 263 | 237 | 190 | 158 |
| | 4.0 | 3.65 | 1369 | 913 | 684 | 548 | 456 | 391 | 342 | 304 | 274 | 219 | 183 |
| | 5.0 | 4.08 | 1530 | 1020 | 765 | 612 | 510 | 437 | 383 | 340 | 306 | 245 | 204 |
| | 6.0 | 4.47 | 1676 | 1118 | 838 | 671 | 559 | 479 | 419 | 373 | 335 | 268 | 224 |
| | 7.0 | 4.83 | 1811 | 1208 | 906 | 725 | 604 | 518 | 453 | 403 | 362 | 290 | 242 |
| 10 | 1.0 | 2.28 | 855 | 570 | 428 | 342 | 285 | 244 | 214 | 190 | 171 | 137 | 114 |
| | 1.5 | 2.79 | 1046 | 698 | 523 | 419 | 349 | 299 | 262 | 233 | 209 | 167 | 140 |
| | 2.0 | 3.23 | 1211 | 808 | 606 | 485 | 404 | 346 | 303 | 269 | 242 | 194 | 162 |
| | 3.0 | 3.95 | 1481 | 988 | 741 | 593 | 494 | 423 | 370 | 329 | 296 | 237 | 198 |
| | 4.0 | 4.56 | 1710 | 1140 | 855 | 684 | 570 | 489 | 428 | 380 | 342 | 274 | 228 |
| | 5.0 | 5.10 | 1913 | 1275 | 956 | 765 | 638 | 546 | 478 | 425 | 383 | 306 | 255 |
| | 6.0 | 5.59 | 2096 | 1398 | 1048 | 839 | 699 | 599 | 524 | 466 | 419 | 335 | 280 |
| | 7.0 | 6.03 | 2261 | 1508 | 1131 | 905 | 754 | 646 | 565 | 503 | 452 | 362 | 302 |
| 15 | 1.0 | 3.42 | 1283 | 855 | 641 | 513 | 428 | 366 | 321 | 285 | 257 | 205 | 171 |
| | 1.5 | 4.19 | 1571 | 1048 | 786 | 629 | 524 | 449 | 393 | 349 | 314 | 251 | 210 |
| | 2.0 | 4.83 | 1811 | 1208 | 906 | 725 | 604 | 518 | 453 | 403 | 362 | 290 | 242 |
| | 3.0 | 5.92 | 2220 | 1480 | 1110 | 888 | 740 | 634 | 555 | 493 | 444 | 355 | 296 |
| | 4.0 | 6.84 | 2565 | 1710 | 1283 | 1026 | 855 | 733 | 641 | 570 | 513 | 410 | 342 |
| | 5.0 | 7.64 | 2865 | 1910 | 1433 | 1146 | 955 | 819 | 716 | 637 | 573 | 458 | 382 |
| | 6.0 | 8.37 | 3139 | 2093 | 1569 | 1256 | 1046 | 897 | 785 | 698 | 628 | 502 | 419 |
| | 7.0 | 9.04 | 3390 | 2260 | 1695 | 1356 | 1130 | 969 | 848 | 753 | 678 | 542 | 452 |

| | | | | | | | | | | | | | |
|----|-----|-------|------|------|------|------|------|------|------|------|-----|-----|-----|
| 20 | 1.0 | 4.56 | 1710 | 1140 | 855 | 684 | 570 | 489 | 428 | 380 | 342 | 274 | 228 |
| | 1.5 | 5.58 | 2093 | 1395 | 1046 | 837 | 698 | 598 | 523 | 465 | 419 | 335 | 279 |
| | 2.0 | 6.44 | 2415 | 1610 | 1208 | 966 | 805 | 690 | 604 | 537 | 483 | 386 | 322 |
| | 3.0 | 7.89 | 2959 | 1973 | 1479 | 1184 | 986 | 845 | 740 | 658 | 592 | 473 | 395 |
| | 4.0 | 9.11 | 3416 | 2278 | 1708 | 1367 | 1139 | 976 | 854 | 759 | 683 | 547 | 456 |
| | 5.0 | 10.19 | 3821 | 2548 | 1911 | 1529 | 1274 | 1092 | 955 | 849 | 764 | 611 | 510 |
| | 6.0 | 11.16 | 4185 | 2790 | 2093 | 1674 | 1395 | 1196 | 1046 | 930 | 837 | 670 | 558 |
| | 7.0 | 12.05 | 4519 | 3013 | 2259 | 1808 | 1506 | 1291 | 1130 | 1004 | 904 | 723 | 603 |

NOTE: The previous tabulations are based on 15-inch/40 cm nozzle spacing. Visit www.teejet.com for tabulations if choosing spacing other than 15"/40 cm.

Verifying Calibration

WARNING

Do not add chemicals until calibration is complete. Contact with chemicals may cause serious injury or death.

To test your system, fill the solution tank with clean water. **Do not add chemicals until calibration is complete.**

1. Apply the parking brake.
2. Start the engine.
3. Throttle the engine to operating speed.
4. Turn the spray system console ON.
5. Change the drive state of the machine to Field Mode on the Machine Display - Home Page.
6. Press the Main Tank Valve Switch (located on the side console) in the UP (Open) position.
7. Press the Master Spray Switch (located on the Hydrostatic Drive Control Handle) in the ON position.
8. Press all Boom Solution Valve Switches (located on the side console) in the ON position.
9. Press the Manual ("MAN") Rate Control Switch (located on the side console).
10. Press the Pump Speed/Rate Switches (located on the side console) in the "+" position to increase flow.
11. Ensure there are no leaks and that all nozzles are spraying a desirable pattern.
12. Continue spraying in the stationary position for at least 10 minutes for proper warm-up of the sprayer and system.

Once the sprayer has had an adequate warm-up period, you will need to perform a "self test" to simulate speed (although the machine will remain stationary).

NOTE: The following "self-test" steps require measuring flow at given pressure.

- Collect one nozzle's spray for one (1) minute in an adequately sized and marked container.
- Verify that the collection equals or is close to the GPM (l/min) for the nozzle, pressure, speed, GPA (l/ha), and spacing that you are using.

Also to ensure accuracy, you will need to verify the flow meter. To do so:

- Collect one nozzle's spray for one (1) minute and multiply it by the number of nozzles on the boom. This should equal the amount measured through the flow meter.

Calculating Spray Width

The spray section widths will need to be entered into the spray system console during initial set-up. No matter what the length of the boom is or how many spray sections it has, the formula for calculating section widths are the same.

$$\text{Number of Nozzles} \times \text{Nozzle Spacing} = \text{Spray Section Width}$$

Example:

Section 2 of a 120-ft. boom with 15-inch (38 cm) nozzle spacing (10 spray nozzles).

$$10 \text{ Nozzles} \times 15 \text{ (Nozzle Spacing)} = 150'' \text{ (Section Width)}$$

$$10 \text{ Nozzles} \times 38 \text{ (Nozzle Spacing)} = 380 \text{ cm (Section Width)}$$



Further Information

Refer to the spray system console manufacturer's operation manual for complete operating and calibrating instructions, troubleshooting tips, and safety precautions.



SECTION 8 – DUAL PRODUCT SPRAY SYSTEMS

SOLUTION SYSTEM COMPONENTS - DUAL PRODUCT

The Dual Product Solution System is a constantly monitored, continuously adjusted computer-controlled system. The cab-mounted digital spray system console receives information from various inputs to help determine gallons per acre (GPA)/liters per hectare (l/ha) and gallons per minute (GPM)/liters per minute (l/min).

Please read and understand the information provided in this manual, as well as the spray system console manufacturer's operation manual before operating the Dual Product Solution System. The following information refers to components of the solution system and is not intended to replace the manufacturer's operating instructions.

- Solution Tank (Split)
- Solution Pumps (2)
- Solution Pump Switch
- Flow Meters (2)
- Pressure Gauges (2)
- Solution Tank Drain Valves (2)
- Solution Tank Valves (2)
- Main Tank Valve Switch
- Agitation Valve
- Agitation Shutoff Valve
- Agitation Valve Switch
- Jet Agitators (2)
- Boom Solution Valve Switches (2 sets)
- Section Indicator Display
- Boom Solution Valve Indicators (Transom), if equipped
- Rate Control Switches
- Pump Speed/Rate Switches
- Master Spray Switch
- Spray System Console
- Wet Booms
- Nozzle Bodies
- Section Strainers (if equipped)
- Solution Line Strainers (2)
- Dual Product Rinse Valve
- Dual Product Sump Valve

- Tank 1 Manual Shutoff Valve
- Air Purge (if equipped)

Solution Tank

The 1600-gallon/6056L (combined) stainless steel Solution Tank (located at the center of the machine) is a split tank and can hold two separate products - 1000 gallons (3785L) in the front tank (Tank 1), and 600 gallons (2271L) in the rear tank (Tank 2). Each side is equipped with a spin ball-type rinse system (one rotating rinse ball in each tank). A dual mechanical sight gauge is located behind the left-hand side of cab to visually check solution level at all times.

NOTE: Typically, fertilizer is stored in Tank 1, and another chemical is stored in Tank 2.



- Tank 1 (1000-gal/3785L)
- Tank 2 (600-gal/2271L)

Solution Tank (Split)
-Typical View

Solution Pumps (2)

Hypro® 9306-HM1C-BU w/silicon carbide seals, 3" (7.6 cm) inlet/2" (5.1 cm) outlet plumbing

The dual Solution Pumps (located beneath rear of machine) are centrifugal-type hydraulically driven pumps that are controlled by the corresponding solution pump control valves and the spray system console.

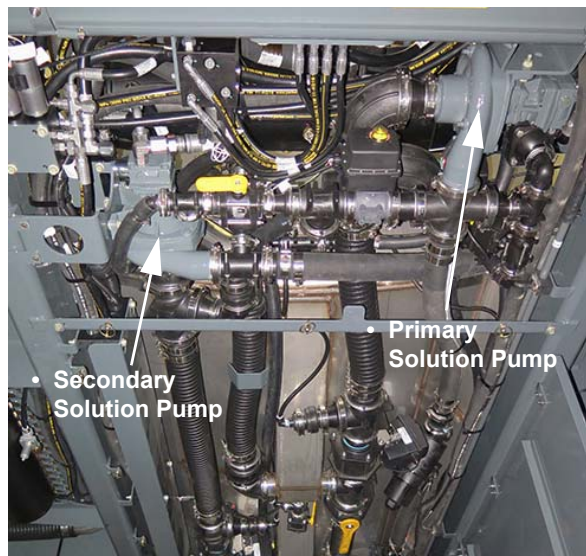

Solution Pumps - Primary/Secondary
(Located beneath rear of machine)
-Typical View

* View looking towards front of machine

Each Solution Pump draws solution out of the corresponding tank side at the rate determined during calibration. They dispense solution through the many valves and hoses that make up the solution system. The pumps also dispense fluids through the Agitation and Rinse Systems.

In **Single Product Mode**, the Primary Solution Pump is always used. In **Dual Product Mode**, both Primary and Secondary Solution Pumps are used - the Primary Solution Pump pulls from the 600-gallon/ 2271L side (Tank 2), and the Secondary Solution Pump pulls from the 1000-gallon/ 3785L side (Tank 1).

Refer to the spray system console manufacturer's operation manual for further information on Solution Pump control.

Solution Pump Switch

The Solution Pump Switch (located on the side console) is used to turn on/off the Primary Solution Pump.

NOTE: The Secondary Solution Pump is controlled through the spray system console.

NOTE: Leaving the Solution Pump Switch in the ON position without flow may result in system damage.

- Press the Solution Pump Switch in the UP position to turn ON (enable).
- Press the Solution Pump Switch in the DOWN position to turn OFF (disable).



Solution Pump Switch - **Primary**
(Located on the side console)
-Typical View

NOTE: When the Primary Solution Pump is ON, a Solution Pump Indicator (located on the Machine Display Home Page - Field Mode) will illuminate.

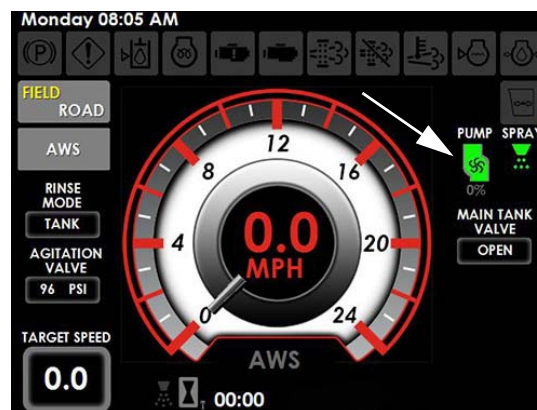

Solution Pump Indicator - **Primary**
(Located on the Machine Display Home Page - Field Mode)

Flow Meters (2) (ARAG® Orion)

The dual Flow Meters (Primary Flow Meter located beneath the center right-hand side of machine, and Secondary Flow Meter located near the front right-hand side of machine) are an electromagnetic-type with

no internal moving parts, which monitors solution flow and sends information back to the spray system console.

NOTE: Flow Meter Usable Range = 3-190 GPM (11.4-719.2 l/min).

NOTE: Flow Meter Calibration = 378 pulses/per gallon (standard volume system). Calibration is listed on the flow meter tag and may vary depending on options and available equipment.

NOTE: John Deere and Raven Controllers: Flow Meter Calibration = 3,780 pulses/per 10 gallons.

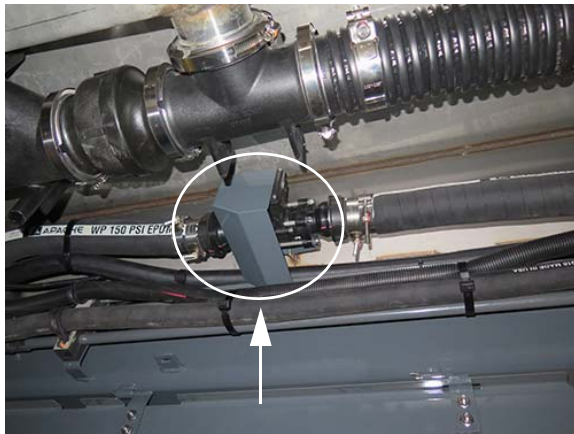

Flow Meter - Primary
(Located beneath the center right-hand side of machine)
-Typical View



Flow Meter - Secondary
(Located near the front right-hand side of machine)
-Typical View

Pressure Gauges (2)

The Pressure Gauges (located on each side of the boom - Primary Pressure Gauge mounted on the right, and Secondary Pressure Gauge mounted on the left) gives a constant visual display of solution pressure being applied (measured in PSI).

NOTE: Pressure will vary according to speed, application, rate, tip size, etc.

NOTE: The Secondary Pressure Gauge for Dual Product is equipped with a second set of wet boom plumbing.



• Secondary Pressure Gauge • Primary Pressure Gauge

Pressure Gauge - Primary/Secondary
(Mounted on the left and right-hand side of boom)
-Typical View

Solution Tank Drain Valves (2)

The Solution Tank Drain Valves - Tanks 1 and 2 (located beneath the solution tank on underside of machine) are used to drain small volumes of residual from each side of the solution tank.

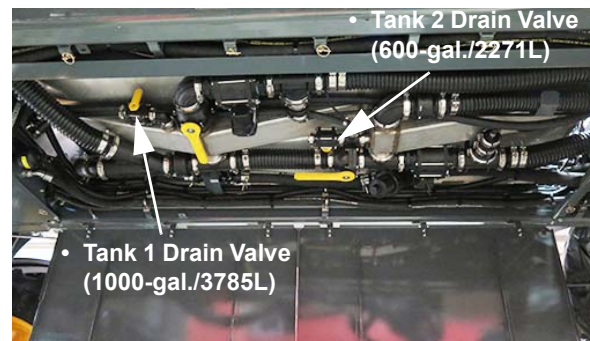

Solution Tank Drain Valves - Tanks 1 and 2
(Located beneath the solution tank on underside of machine)
-Typical View

Refer to “Draining Your Solution Tank” elsewhere in this section for further information.

Solution Tank Valves (2)

The Solution Tank Valves - Tanks 1 and 2 (located beneath the solution tank on underside of machine) are electric tank shut-off valves. These valves are controlled by the Main Tank Valve Switch (located on the side console).



Solution Tank Valves - Tanks 1 and 2
(Located beneath the solution tank on underside of machine)
-Typical View

Main Tank Valve Switch

The Main Tank Valve Switch (located on the side console) controls both of the solution tank valves for Tanks 1 and 2.

- Press the Main Tank Valve Switch in the UP (On) position to open the solution tank valves.
- Press the Main Tank Valve Switch in the DOWN (Off) position to close the solution tank valves.



Main Tank Valve Switch
(Located on the side console)
-Typical View

NOTE: Main Tank Valve status (OPEN or CLOSED) is displayed on the Machine Display Home Page - Field Mode.

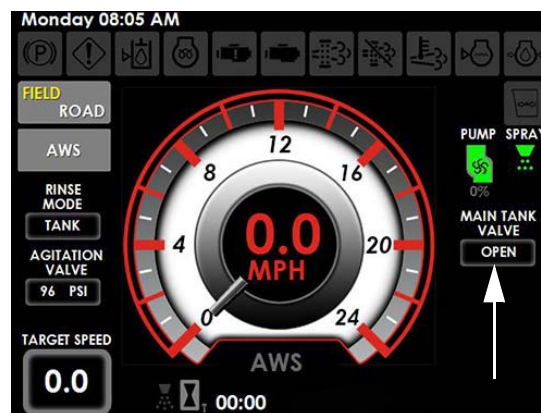

Main Tank Valve Status Indicator
(Located on the Machine Display Home Page - Field Mode)

Agitation Valves

(Electrical Actuation and Manual Shutoff)

The flow rate of the Agitation System is controlled by the Agitation Valve (located beneath rear of machine) to thoroughly mix solution in the tank and regulate pressure and flow to the jet agitators. Increase or decrease agitation flow by operating the Agitation Valve Switch (located on the side console).

A manual Agitation Shutoff Valve (located beneath rear of machine) is provided to select tank agitation in either Dual or Single Product Mode.

- **Dual Product Mode** - Rotate the Agitation Shutoff Valve in the CLOSED (clockwise) position to stop agitation of the front tank (Tank 1).
- **Single Product Mode** - Rotate the Agitation Shutoff Valve in the OPEN (counter-clockwise) position to allow agitation of the front tank (Tank 1).

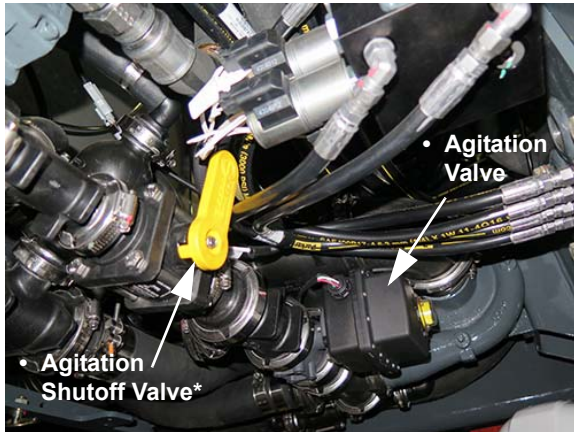

Agitation Valve and Agitation Shutoff Valve
(Located beneath rear of machine)
-Typical View

* Agitation Shutoff Valve shown in the CLOSED position (Dual Product Mode)

Agitation Valve Switch

The Agitation Valve Switch (located on the side console) is used to increase or decrease the agitation valve flow rate.



Agitation Valve Switch
(Located on the side console)
-Typical View

- **To increase flow**, press and hold the Agitation Valve Switch in the UP position.
- **To decrease flow**, press and hold the Agitation Valve Switch in the DOWN position.
- Release the Agitation Valve Switch when desired rate of flow is achieved.
- To turn the Agitation System OFF, decrease the flow rate all the way down.

NOTE: Agitation Valve pressure is displayed on the Machine Display Home Page - Road and Field Mode.



Agitation Valve Pressure Indicator
(Located on the Machine Display Home Page - Road and Field Mode)

Jet Agitators (2)

The Jet Agitators (located on each end of the solution tank) are an integral part of the Agitation System. 5/16” nozzles are located on the end of each Jet Agitator (inside of the solution tank) and provide ample agitation and solution suspension.

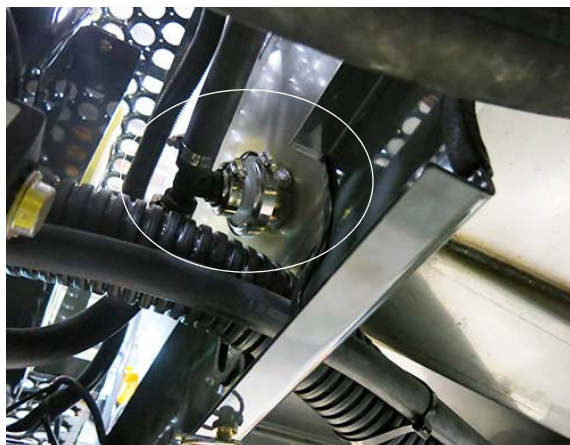

Jet Agitator (2)
(Located on each end of the solution tank)
-Typical View



Boom Solution Valve Switches (2) (Single and Dual Product Section Keypads)

The spray booms are divided into sections that are independently supplied with solution and can be turned on or off individually. The electrically-operated boom solution valves are controlled by the Boom Solution Valve Switches (located on the section keypad).

In **Single Product Mode**, the Single Product Section Keypad is always used (Primary Solution System, Sections 1-9). In **Dual Product Mode**, both Single Product and Dual Product Section Keypads are used (Secondary Solution System, Sections 10-14).

- Press the Boom Solution Valve Switches to turn ON. Press again to turn OFF.

NOTE: Each Boom Solution Valve Switch is equipped with an indicator light and will illuminate when the corresponding boom solution valve is OFF.



Boom Solution Valve Switches -
Single Product Section Keypad
(Located on the side console)
-Typical View

** Used with 9-section wet boom*



Boom Solution Valve Switches - Dual Product Section Keypad
(Mounted near the side console)
-Typical View

** Used with 5-section wet boom*

NOTE: Fence Row, Rear Nozzle, Rate Control, and Pump Speed/Rate Switches are inactive on the Dual Product Section Keypad.

Section Indicator Display

(Used for Primary System only)

The Section Indicator Display (located on the cab headliner) allows you to view system status for the following:

- (1) - Master Spray Indicator (illuminates when ON).
- (2) - Fence Row Indicators (illuminate when ON).
- (9) - Spray Section Indicators (illuminate when OFF).
- (1) - Rear Wheel Nozzle Indicator (illuminates when ON).

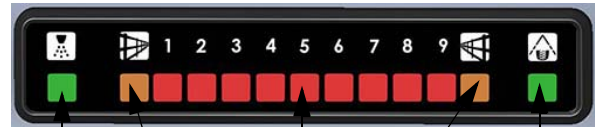

- Master Spray
- Left Fence Row
- Spray Section
- Right Fence Row
- Rear Wheel Nozzle

Section Indicator Display
(Located on the cab headliner)
-Typical View

** Used for primary system only*

Boom Solution Valve Indicators (Transom)

-If Equipped

(Used for Primary System only)

Your machine may be equipped with transom-mounted Boom Solution Valve Indicators (located on the center of the transom), which allow you to view system status for the following:

- (2) - Fence Row Indicators (illuminate when ON).
- (1) - Master Spray Indicator (illuminates when ON).
- (9) - Spray Section Indicators (illuminate when OFF).



Boom Solution Valve Indicators
(Located on transom)
-Typical View

** Used for primary system only*

Rate Control Switches

(Used for Primary System only)

NOTE: The Dual Product System rate control is controlled through the spray system console.

The Rate Control Switches (located on the side console) control the rate in which solution is applied through the spray booms.

- Press ENABLE to allow the rate controller to control the application rate.
- Press MAN (Manual) to control application rate from the section keypad.
- Press ENABLE and MAN to enable manual rate control through the rate controller.

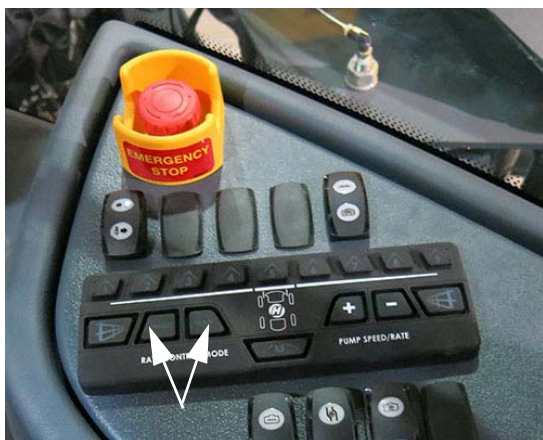

Rate Control Switches
(Located on the side console)
-Typical View

* Used for primary system only

NOTE: When “MAN” is selected, press the Pump Speed/Rate Switches (located on the side console) to increase (+) or decrease (-) application rate. Current solution pump speed is displayed below the Solution Pump Indicator (located on the Machine Display Home Page - Field Mode).

Pump Speed/Rate Switches (Used for Primary System only)

NOTE: The Dual Product System pump speed/rate is controlled through the spray system console.

The Pump Speed/Rate Switches (located on the side console) control the flow rate through the spray system.

NOTE: These switches are enabled when the “MAN” Rate Control Switch (located on the side console) is previously selected.

- Press “+” to INCREASE Solution Pump speed.
- Press “-” to DECREASE Solution Pump speed.



Pump Speed/Rate Switches
(Located on the side console)
-Typical View

* Used for primary system only

NOTE: Increasing or decreasing pump speed will change the application rate through the rate controller.

Master Spray Switch

Boom solution valve switches are controlled by the Master Spray Switch (located on the Hydrostatic Drive Control Handle) and must be ON to open the electronically-operated boom solution valves.

This allows you to turn all of the boom solution valves on or off at the same time, such as turning them off when you reach the end rows, and turning them back on when you re-enter the field.



Master Spray Switch
(Located on the Hydrostatic
Drive Control Handle)
-Typical View

NOTE: When the Master Spray Switch is ON, a Master Spray Indicator (located on the Machine Display Home Page - Field Mode) will illuminate.



Master Spray Indicator
(Located on the Machine Display
Home Page - Field Mode)

Spray System Console

The spray system is controlled by the Spray System Console and the Solution Pump Control Valves. The system receives

data and automatically makes adjustments based on the target rate of application set by the operator.

Refer to the Spray System Console manufacturer's operation manual for complete calibration and operating instructions.



Spray System Console
-Typical View
(Your machine may vary according to model and available equipment)

Wet Boom

The 9-section (Single Product) and 5-section (Dual Product) Wet Boom on your machine is featured with 1" (2.5 cm) schedule 5 stainless plumbing and delivers solution directly to the spray nozzles, which allows for ease of flushing and cleaning of the boom, as well as decreased contamination/plugging of nozzles.

The Wet Booms are equipped with Hypro® Express end caps on the end of the boom tubing, which aid in eliminating trapped air from the boom by allowing air to escape through the nozzle body, reducing nozzle turn-off time. The end caps are equipped with a "quick-release" feature to assist in flushing the Wet Boom tubes.



Wet Boom Plumbing
-Typical View



Hypro Express End Cap
-Typical View

Refer to “Spray Booms” elsewhere in this section for further information.

Nozzle Bodies

Nozzle Bodies are located throughout the boom and consist of a spray tip, gasket, and cap. The spray tip breaks the solution into droplets of correct size and forms a uniform spray pattern.

NOTE: Dual Product System is equipped with single Nozzle Bodies.



Nozzle Body
(Located throughout boom)
-Typical View

Visit www.teejet.com for further information.

Section Strainers

-If Equipped (80-Mesh Strainer Screens)

Section Strainers are located throughout each boom section and filter impurities to aid in the avoidance of spray nozzle buildup.

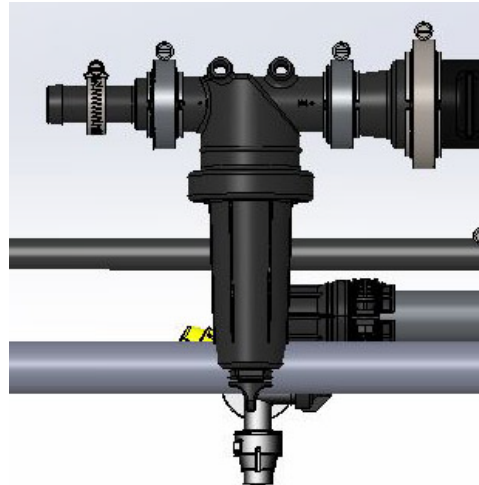

Section Strainers
(Located throughout each boom section)
-Typical View

Refer to “Service - Filters” provided in the *Maintenance and Storage Section* elsewhere in this manual for maintenance information.

Solution Line Strainers (2)

(50-Mesh Strainer Screen)

Solution Line Strainers are located beneath the center right-hand side of machine (Primary), and near the front right-hand side of machine (Secondary) and are the main strainers to filter solution system impurities and maintain consistent application rates.

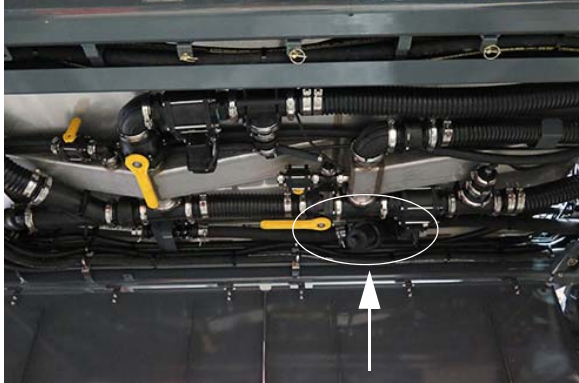

Solution Line Strainer - Primary
(Located beneath the center
right-hand side of machine)
-Typical View



Solution Line Strainer - Secondary
(Located near the front
right-hand side of machine)
-Typical View

Refer to “Service - Filters” provided in the *Maintenance and Storage Section* elsewhere in this manual for maintenance information.

Dual Product Rinse Valve

The Dual Product Rinse Valve (located on top of the solution tank) allows you to rinse Tank 2 without having to rinse Tank 1.

Example:

If the operator desires to change the chemical being applied (in Tank 2) and is still going to apply fertilizer, he or she can rinse the chemical tank (Tank 2) before changing to a new product, while continuing use the fertilizer (in Tank 1).



Dual Product Rinse Valve
(Located on top of the solution tank)
-Typical View

* Dual Product Rinse Valve shown in the
CLOSED position (Dual Product Mode)

Dual Product Sump Valve

The Dual Product Sump Valve (located beneath center of machine) is a 3” flange ball valve that manually separates Tank 1 from Tank 2.

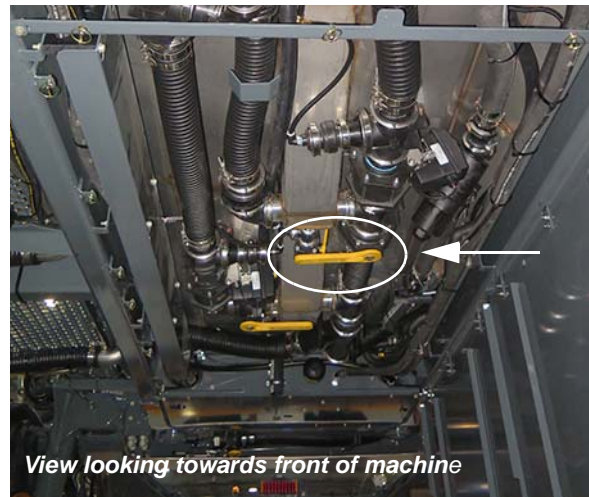

Dual Product Sump Valve
(Located beneath center of machine)
-Typical View

* Dual Product Sump Valve shown in the
CLOSED position (Dual Product Mode)

Tank 1 Manual Shutoff Valve

The Tank 1 Manual Shutoff Valve (located beneath center of machine) is a 3” flange ball valve that manually stops chemical from entering Tank 2.



Tank 1 Manual Shutoff Valve
(Located beneath center of machine)
-Typical View

* Tank 1 Manual Shutoff Valve shown in
the OPEN position (Dual Product Mode)

Air Purge

-If Equipped

The Air Purge feature on your machine allows you to blow out product from the spray system. You may choose to perform the air purge in either manual or automatic mode.

In **Manual Mode**, the operator has control of the solution valves by manipulating the Boom Solution Valve Switches (located on the side console section keypad).

- Single Product - Purges Sections 1-9.
- Dual Product - Purges Sections 10-14.

In **Automatic Mode**, the air tank on the machine is filled based on engine speed and time to automatically recharge the air tank and purge the spray system. Automatic Air Purge settings include: Full Boom Purge, Individual Section Purge, Air Recharge Time, and Minimum Engine Speed.

NOTE: Automatic Mode is only allowed with Single Product (Sections 1-9).

Refer to “Machine Display” provided in the *Cab Section* of your machine operator’s manual for further information on adjusting Air Purge settings and operating instructions.

SOLUTION SYSTEM OPERATION - DUAL PRODUCT

NOTICE

The Solution System has been tested using RV-type antifreeze. Fill solution tank with fresh water and drain before initial use.

NOTICE

Never attempt to operate the spray system without solution in the tank. Failure to comply will cause severe equipment damage and will void the warranty.

NOTE: Ensure the Master Spray Switch (located on the Hydrostatic Drive Control Handle) is in the OFF position before activating the Primary/Secondary Solution Pumps or the Boom Solution Valve Switches, unless you are ready to begin spray application.

Getting Started

1. Ensure there is adequate amount of solution in the tank.

NOTE: Typically, Tank 1 is used for fertilizer and Tank 2 is used for another chemical.

2. Rotate the Dual Product Rinse Valve (located on top of the solution tank) in the CLOSED (clockwise) position.



Dual Product Rinse Valve
(Located on top of the solution tank)
-Typical View

* Dual Product Rinse Valve shown in the
CLOSED position (Dual Product Mode)

3. Rotate the Agitation Shutoff Valve (located beneath rear of machine) in the CLOSED (clockwise) position to stop agitation of the front tank (Tank 1).



Agitation Shutoff Valve
(Located beneath rear of machine)
-Typical View

* Agitation Shutoff Valve shown in the
CLOSED position (Dual Product Mode)

4. Rotate the Dual Product Sump Valve (located beneath center of machine) in the CLOSED (clockwise) position.

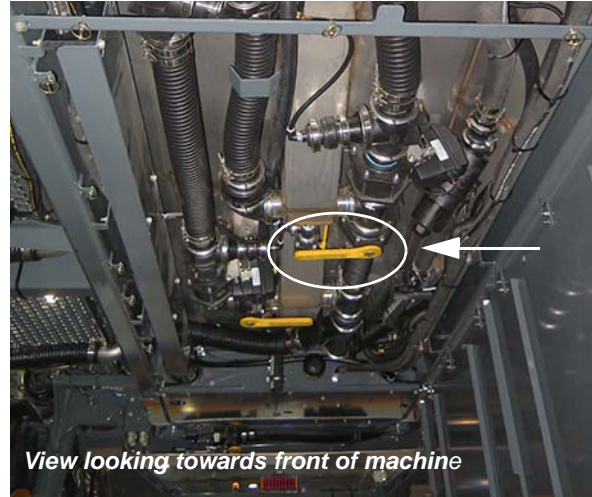

Dual Product Sump Valve
(Located beneath center of machine)
-Typical View

* Dual Product Sump Valve shown in the
CLOSED position (Dual Product Mode)

5. Rotate the Tank 1 Manual Shutoff Valve (located beneath center of machine) in the OPEN (counter-clockwise) position.

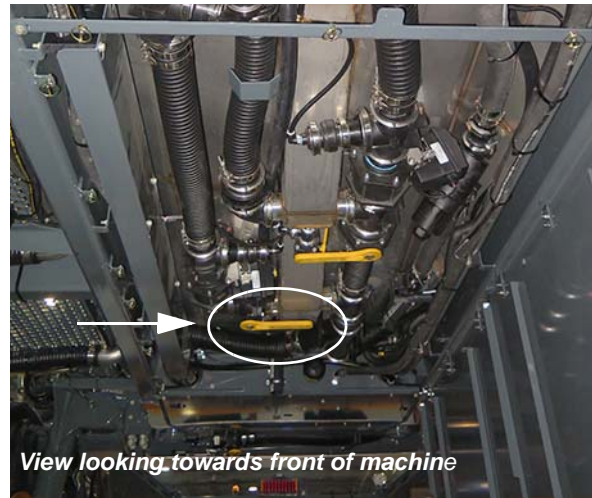

Tank 1 Manual Shutoff Valve
(Located beneath center of machine)
-Typical View

* Tank 1 Manual Shutoff Valve shown in
the OPEN position (Dual Product Mode)

6. Calibrate the spray system console (refer to the manufacturer's operation manual for calibration instructions).
7. Engage the parking brake.
8. Start the engine.

9. Press the Field/Road Button (located on the Machine Display Home Page) and change the machine's drive state to FIELD.

NOTE: The drive state of the machine cannot be changed unless the Hydrostatic Drive Control Handle is in the NEUTRAL position (and machine speed is less than 0.5 mph/ 0.8 km/h).



Field/Road Button
(Located on the
Machine Display Home Page)

NOTE: The selected drive state will illuminate.

10. Position boom to desired position.
11. Press the Main Tank Valve Switch (located on the side console) in the UP (Open) position.

NOTE: The Main Tank Valve Switch activates both of the electric solution tank valves for Tanks 1 and 2.



Main Tank Valve Switch
(Located on the side console)
-Typical View

NOTE: Main Tank Valve status (OPEN or CLOSED) is displayed on the Machine Display Home Page (Field Mode).

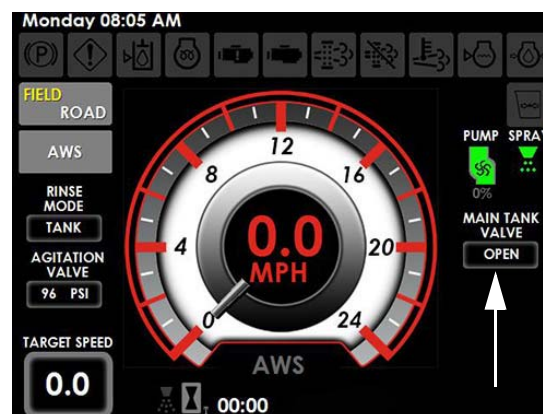

Main Tank Valve Status Indicator
(Located on the Machine Display
Home Page - Field Mode)

12. Press the Solution Pump Switch (located on the side console) in the UP (On) position to activate the Primary Solution Pump.

NOTICE

Do not allow the Solution Pump to run continuously while the Boom Solution Valve Switches are off. Failure to comply will generate overheating, causing severe pump damage and will void the warranty.



Solution Pump Switch - **Primary**
(Located on the side console)
-Typical View

13. Press the Solution Pump Button (located on the spray system console) to activate the Secondary Solution Pump.

NOTICE

Do not allow the Solution Pump to run continuously while the Boom Solution Valve Switches are off. Failure to comply will generate overheating, causing severe pump damage and will void the warranty.

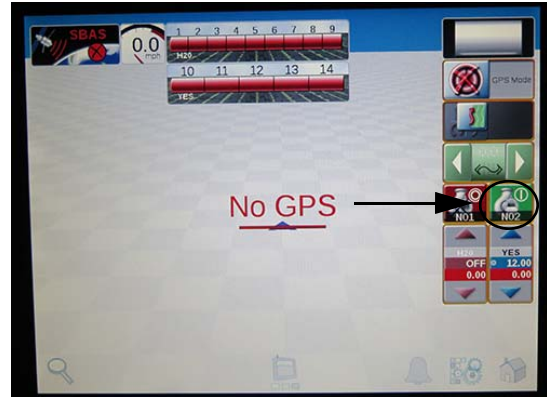

Solution Pump Button - **Secondary**
(Located on the spray system console)
-Typical View

14. If desired, activate the Agitation System by pressing and holding the Agitation Valve Switch (located on the side console) in the UP position to increase flow, or in the DOWN position to decrease flow.

NOTE: Agitation Valve pressure is displayed on the Machine Display Home Page (Field Mode).



Agitation Valve Pressure Indicator
(Located on the Machine Display Home Page - Field Mode)

15. Press the Master Spray Switch (located on the Hydrostatic Drive Control Handle) in the ON position.



Master Spray Switch
(Located on the Hydrostatic
Drive Control Handle)
-Typical View

NOTE: When the Master Spray Switch is ON, a Master Spray Indicator (located on the Machine Display Home Page - Field Mode) will illuminate.

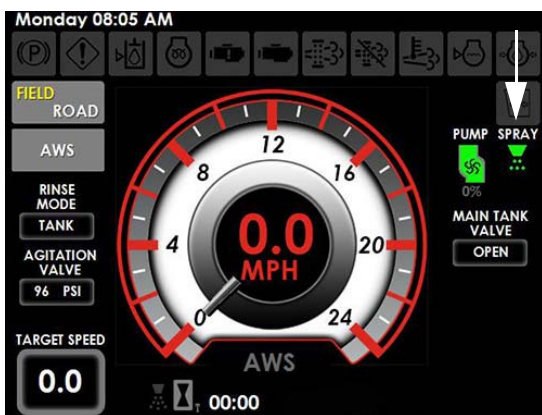

Master Spray Indicator
(Located on the Machine Display
Home Page - Field Mode)

16. Press the individual Boom Solution Valve Switches (located on the Single and Dual Product Section Keypads) to the ON (non-illuminated) position.

NOTE: Each Boom Solution Valve Switch is equipped with an indicator light and will illuminate when the corresponding Boom Solution Valve is OFF.



Boom Solution Valve Switches -
Single Product Section Keypad,
Sections 1-9

(Located on the side console)
-Typical View
** Used with 9-section wet boom*



Boom Solution Valve Switches -
Dual Product Section Keypad,
Sections 10-14

(Mounted near the side console)
-Typical View
** Used with 5-section wet boom*

NOTE: Fence Row, Rear Nozzle, Rate Control, and Pump Speed/Rate Switches are inactive on the Dual Product Section Keypad.

Dual Product System rate control and pump speed/rate is controlled through the spray system console.

17. Slowly move the Hydrostatic Drive Control Handle forward to obtain desired ground speed.
18. Frequently observe the pressure gauges. If pressure on either gauge drops to zero or spray pattern deteriorates, turn OFF the Master Spray, Solution Pumps, Main Tank Valve Switch, and Agitation Valve Switch until solution is refilled.

RINSE SYSTEM - DUAL PRODUCT

Your machine is equipped with a spin ball-type Rinse System (one rotating rinse ball located inside each side of the solution tank) to easily and effectively rinse the solution tank (Tank 2 individually, or Tanks 1 and 2 combined), solution pumps, and spray booms with fresh water, which protects against cross-contamination of chemicals, as well as reduces the risk of operator exposure.

The operator may choose to rinse the entire solution tank, as well as primary/secondary solution systems, or just rinse Tank 2 and the primary solution system. The Dual Product Rinse System is equipped with a Dual Product Rinse Valve (located on top of the solution tank), which allows Tank 2 to be rinsed without having to rinse Tank 1.

Example:

If the operator desires to change the chemical being applied (in Tank 2) and is still going to apply fertilizer, he or she can rinse the chemical tank (Tank 2) before changing to a new product, while continuing use the fertilizer (in Tank 1).

With a 100-gallon (378L) rinse tank (mounted on top of the solution tank) full of fresh water, you may rinse the sprayer out immediately after spraying while still in the field. The Rinse System also reduces the extra costs of large volumes of water, as well

as additional refilling and sprayer time that are associated with conventional tank rinsing.

NOTE: Depending on which rinse option you decide (Single or Dual Product Rinse), ensure the solution tank is completely empty of chemical before activating the Rinse System.

NOTICE

Select a safe area to rinse the spray system and clean the sprayer where chemicals will not drift off to contaminate people, animals, vegetation, or water supply.

NOTICE

Never attempt to operate the Rinse System without fresh water in the rinse tank. Failure to comply will result in equipment damage and will void the warranty.

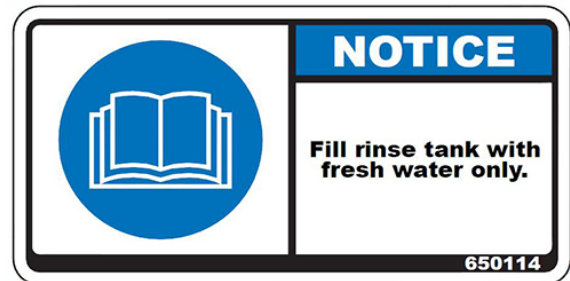

Refer to the chemical manufacturer's information for types of cleaning solution combinations (water, cleaning agents, etc.)

Dual Product Rinse (Tank 2)

NOTE: The following steps are for rinsing Tank 2 only. If rinsing of both Tanks 1 and 2 is desired, follow the steps in "Dual Product Rinse - Tanks 1 and 2" elsewhere in this section.

Step 1 - Rinsing Tank 2

1. Rotate the Dual Product Rinse Valve (located on top of the solution tank) in the CLOSED (clockwise) position.



Dual Product Rinse Valve
(Located on top of the solution tank)
-Typical View

** Dual Product Rinse Valve
shown in the CLOSED position*

2. Rotate the Agitation Shutoff Valve (located beneath rear of machine) in the CLOSED (clockwise) position.



Agitation Shutoff Valve
(Located beneath rear of machine)
-Typical View

** Agitation Shutoff Valve
shown in the CLOSED position*

3. Press the Main Tank Valve Switch (located on the side console) in the DOWN (Closed) position.



Main Tank Valve Switch
(Located on the side console)
-Typical View

4. Press the Rinse Switch (located on the side console) in the DOWN position to rinse Tank 2.



Rinse Switch
(Located on the side console)
-Typical View

NOTE: A Rinse Mode Indicator is located on the Machine Display Home Page - Field Mode and will display current rinse mode status (TANK or BOOM).



Rinse Mode Indicator
(Located on the Machine Display
Home Page - Field Mode)

5. Press and hold the Agitation Valve Switch (located on the side console) in the UP (Open) position.



Agitation Valve Switch
(Located on the side console)
-Typical View

6. Press the Solution Pump Switch (located on the side console) in the UP (On) position.



Solution Pump Switch
(Located on the side console)
-Typical View

7. Press the Manual (MAN) Rate Control Switch (located on the side console).

NOTE: Ensure the Enable Rate Control Switch is in the OFF position.



Manual "MAN" Rate Control Switch
(Located on the side console)
-Typical View

8. Press the "+" Pump Speed/Rate Switch (located on the side console) to increase solution pressure to desired PSI (bar).



“+” Pump Speed/Rate Switch
(Located on the side console)
-Typical View



Boom Solution Valve Switches -
Single Product Section Keypad,
Sections 1-9

(Located on the side console)
-Typical View

** Used with 9-section wet boom*

9. When finished rinsing Tank 2, press the Rinse Switch to the OFF (mid) position.

Step 2 - Spray Diluted Water from Tank 2

1. Press and hold the Agitation Valve Switch (located on the side console) in the DOWN (Closed) position.
2. Press the Main Tank Valve Switch (located on the side console) in the UP (Open) position.
3. Press the individual Boom Solution Valve Switches (located on the Single Product Section Keypad) to the ON (non-illuminated) position.

NOTE: Each Boom Solution Valve Switch is equipped with an indicator light and will illuminate when the corresponding Boom Solution Valve is OFF.

4. Press the Master Spray Switch (located on the Hydrostatic Drive Control Handle) in the ON position.



Master Spray Switch
(Located on the Hydrostatic
Drive Control Handle)
-Typical View

5. Continue spraying until all diluted water is removed from Tank 2.

NOTICE

Do not allow the solution pump to run dry for a prolonged period of time. Failure to comply may result in pump damage.

Step 3 - Rinsing the Boom and Nozzles

1. Press the Main Tank Valve Switch (located on the side console) in the DOWN (Closed) position.



Main Tank Valve Switch
(Located on the side console)
-Typical View

NOTE: When rinsing the boom and nozzles, ensure the Boom Solution Valve Switches (located on the Single Product Section Keypad) are in the ON position before activating the Rinse Switch.

2. Press the Rinse Switch (located on the side console) in the UP position to rinse the boom and nozzles.



Rinse Switch
(Located on the side console)
-Typical View

NOTE: A Rinse Mode Indicator is located on the Machine Display Home Page - Field Mode and will display current rinse mode status (TANK or BOOM).



Rinse Mode Indicator
(Located on the Machine Display
Home Page - Field Mode)

3. When finished rinsing the booms, press the Master Spray Switch (located on the Hydrostatic Drive Control Handle) in the OFF position.
4. Press the Solution Pump Switch (located on the side console) in the DOWN (Off) position.
5. When rinsing is complete, press the Rinse Switch to the OFF (mid) position.

Dual Product Rinse (Tanks 1 and 2)

Step 1 - Rinsing Tanks 1 and 2

1. Rotate the Dual Product Rinse Valve (located on top of the solution tank) in the OPEN (counter-clockwise) position.



Dual Product Rinse Valve
(Located on top of the solution tank)
-Typical View

** Dual Product Rinse Valve
shown in the CLOSED position*

2. Rotate the Agitation Shutoff Valve (located beneath rear of machine) in the OPEN (counter-clockwise) position.

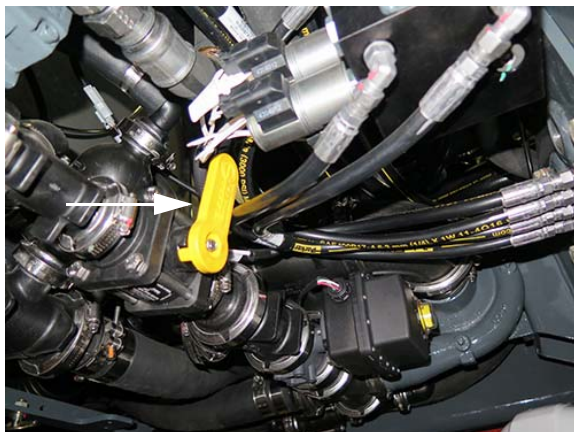

Agitation Shutoff Valve
(Located beneath rear of machine)
-Typical View

** Agitation Shutoff Valve
shown in the CLOSED position*

3. Press the Main Tank Valve Switch (located on the side console) in the DOWN (Closed) position.



Main Tank Valve Switch
(Located on the side console)
-Typical View

4. Press the Rinse Switch (located on the side console) in the DOWN position to rinse Tanks 1 and 2.



Rinse Switch
(Located on the side console)
-Typical View

NOTE: A Rinse Mode Indicator is located on the Machine Display Home Page - Field Mode and will display current rinse mode status (TANK or BOOM).



Rinse Mode Indicator
(Located on the Machine Display
Home Page - Field Mode)

5. Press and hold the Agitation Valve Switch (located on the side console) in the UP (Open) position.



Agitation Valve Switch
(Located on the side console)
-Typical View

6. Press the Solution Pump Switch (located on the side console) in the UP (On) position.



Solution Pump Switch
(Located on the side console)
-Typical View

7. Press the Manual (MAN) Rate Control Switch (located on the side console).

NOTE: Ensure the Enable Rate Control Switch is in the OFF position.



Manual "MAN" Rate Control Switch
(Located on the side console)
-Typical View

8. Press the "+" Pump Speed/Rate Switch (located on the side console) to increase solution pressure to desired PSI (bar).



“+” Pump Speed/Rate Switch
(Located on the side console)
-Typical View



Boom Solution Valve Switches -
Single Product Section Keypad,
Sections 1-9

(Located on the side console)
-Typical View

* Used with 9-section wet boom

9. When finished rinsing the tanks, press the Rinse Switch to the OFF (mid) position.

Step 2 - Spray Diluted Water from Tanks 1 and 2

PRIMARY SYSTEM

1. Press and hold the Agitation Valve Switch (located on the side console) in the DOWN (Closed) position.
2. Press the Main Tank Valve Switch (located on the side console) in the UP (Open) position.
3. Press the individual Boom Solution Valve Switches (located on the Single Product Section Keypad) to the ON (non-illuminated) position.

NOTE: Each Boom Solution Valve Switch is equipped with an indicator light and will illuminate when the corresponding Boom Solution Valve is OFF.

4. Press the Master Spray Switch (located on the Hydrostatic Drive Control Handle) in the ON position.



Master Spray Switch
(Located on the Hydrostatic
Drive Control Handle)
-Typical View

5. Continue spraying until all diluted water is removed from tanks.

NOTICE

Do not allow the solution pump to run dry for a prolonged period of time. Failure to comply may result in pump damage.

SECONDARY SYSTEM

6. Rotate the Agitation Shutoff Valve (located beneath rear of machine) in the CLOSED (clockwise) position.



Agitation Shutoff Valve
(Located beneath rear of machine)
-Typical View

** Agitation Shutoff Valve shown in the CLOSED position*

7. Press the Main Tank Valve Switch (located on the side console) in the UP (Open) position.



Main Tank Valve Switch
(Located on the side console)
-Typical View

8. Press the individual Boom Solution Valve Switches (located on the Dual Product Section Keypad) to the ON (non-illuminated) position.

NOTE: Each Boom Solution Valve Switch is equipped with an indicator light and will illuminate when the corresponding Boom Solution Valve is OFF.



Boom Solution Valve Switches -
Dual Product Section Keypad
(Mounted near the side console)
-Typical View

** Used with 5-section wet boom*

9. Press the Master Spray Switch (located on the Hydrostatic Drive Control Handle) in the ON position.



Master Spray Switch
(Located on the Hydrostatic
Drive Control Handle)
-Typical View

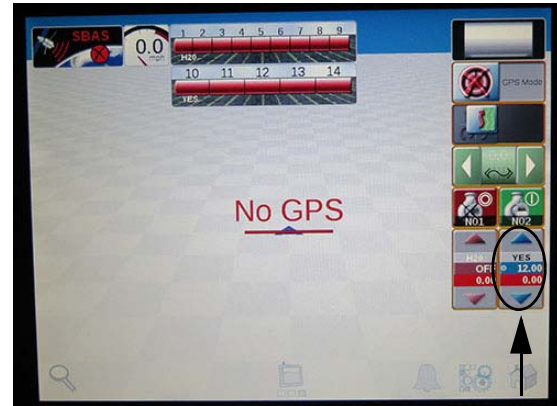

Secondary Product Button
(Located on the spray system console)
-Typical View
** Your machine may vary,
depending on available equipment*

10. Turn on the spray system console.
11. Ensure “Dual Product Machine Configuration” is selected, then press START JOB.



Spray System Console - Getting Started
-Typical View
** Your machine may vary,
depending on available equipment*

13. Press and hold the Secondary Solution Pump Button (located on the spray system console) in the ON position until the “pump control screen” appears.

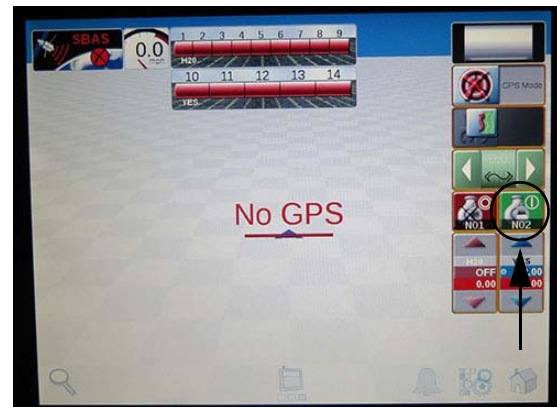

Solution Pump Button - **Secondary**
(Located on the spray system console)
-Typical View
** Your machine may vary,
depending on available equipment*

12. Press and hold the Secondary Product Button (located on the spray system console) in the ON position.

14. Press the Manual (MAN) Rate Control Button (located on the spray system console).

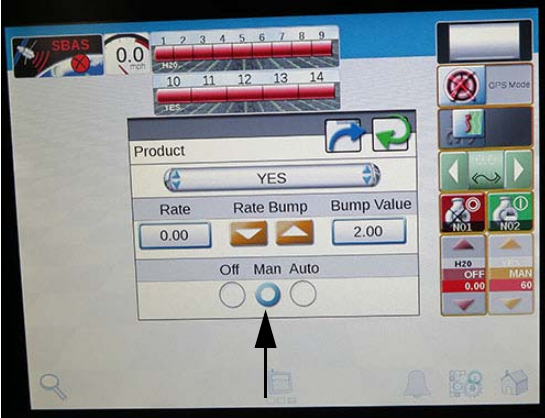

Manual (MAN) Rate Control Button
(Located on the spray system console)
-Typical View

** Your machine may vary,
depending on available equipment*

15. Press the pump Rate Bump Button (located on the spray system console) in the UP position to increase solution pressure to desired PSI (bar).

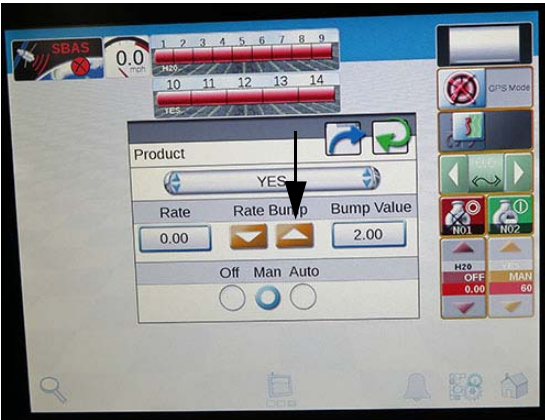

Rate Bump Button
(Located on the spray system console)
-Typical View

** Your machine may vary,
depending on available equipment*

Step 3 - Rinsing the Boom and Nozzles

PRIMARY SYSTEM

1. Press the Main Tank Valve Switch (located on the side console) in the DOWN (Closed) position.



Main Tank Valve Switch
(Located on the side console)
-Typical View

NOTE: When rinsing the boom and nozzles, ensure the Boom Solution Valve Switches (located on the Single Product Section Keypad) are in the ON position before activating the Rinse Switch.

2. Press the Rinse Switch (located on the side console) in the UP position to rinse the boom and nozzles.



Rinse Switch
(Located on the side console)
-Typical View

NOTE: A Rinse Mode Indicator is located on the Machine Display Home Page - Field Mode and will display current rinse mode status (TANK or BOOM).



Rinse Mode Indicator
(Located on the Machine Display
Home Page - Field Mode)

3. When finished rinsing the booms, press the Master Spray Switch (located on the Hydrostatic Drive Control Handle) in the OFF position.
4. Press the Solution Pump Switch (located on the side console) in the DOWN (Off) position.
5. When rinsing is complete, press the Rinse Switch to the OFF (mid) position.

SECONDARY SYSTEM

6. Press the Main Tank Valve Switch (located on the side console) in the DOWN (Closed) position.



Main Tank Valve Switch
(Located on the side console)
-Typical View

NOTE: When rinsing the boom and nozzles, ensure the Boom Solution Valve Switches (located on the Dual

Product Section Keypad) are in the ON position before activating the Rinse Switch.

7. Press the Rinse Switch (located on the side console) in the UP position to rinse the boom and nozzles.



Rinse Switch
(Located on the side console)
-Typical View

8. Press the Master Spray Switch (located on the Hydrostatic Drive Control Handle) in the OFF position.



Master Spray Switch
(Located on the Hydrostatic
Drive Control Handle)
-Typical View

9. Press the pump Rate Bump Button (located on the spray system console) in the DOWN position to decrease solution pressure to desired PSI (bar).

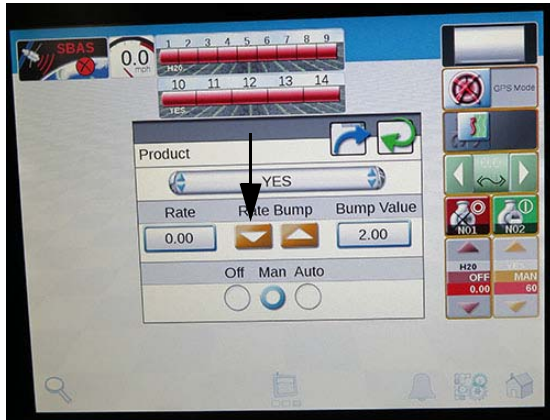

Rate Bump Button
(Located on the spray system console)
-Typical View
** Your machine may vary,
depending on available equipment*

10. Press the Auto Rate Control Button (located on the spray system console).

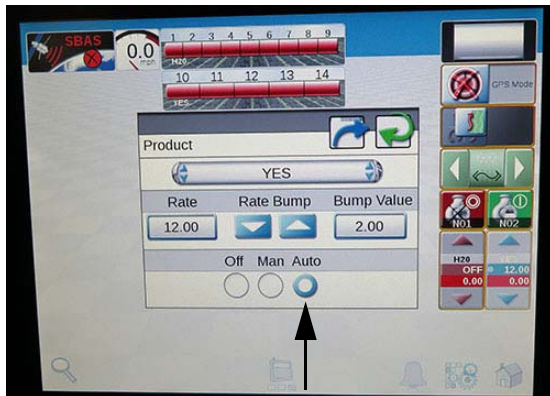

Auto Rate Control Button
(Located on the spray system console)
-Typical View
** Your machine may vary,
depending on available equipment*

11. Press the “back” Arrow Button (located on the spray system console) to close the “pump control screen”.

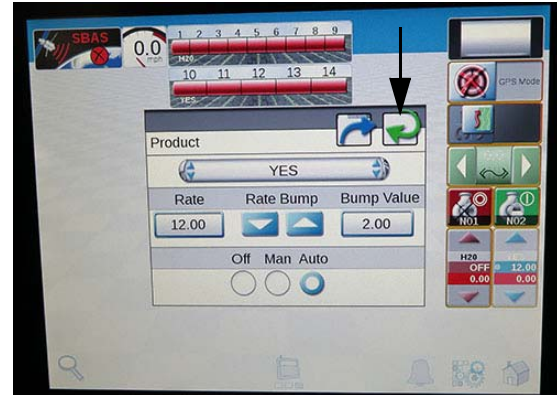

Arrow Button (Back)
(Located on the spray system console)
-Typical View
** Your machine may vary,
depending on available equipment*

12. Press the Stop Button (located on the spray system console) to close the job.



Stop Button
(Located on the spray system console)
-Typical View
** Your machine may vary,
depending on available equipment*

13. Press the Home Button and turn off spray system console (if desired).
14. When rinsing is complete, press the Rinse Switch to the OFF (mid) position.

FILLING YOUR SOLUTION TANK - DUAL PRODUCT

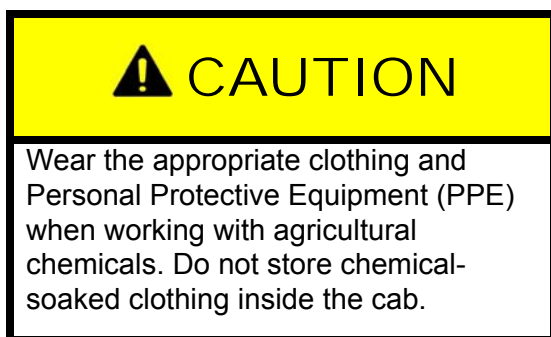

Front Fill

NOTE: The Front Fill is for filling Tank 1 only (when in Dual Product mode).

Filling the Solution Tank (Tank 1)

1. Pull the Front Fill Release Lever (located beneath front end of machine) OUT (toward operator) to unlock the Front Fill Assembly.

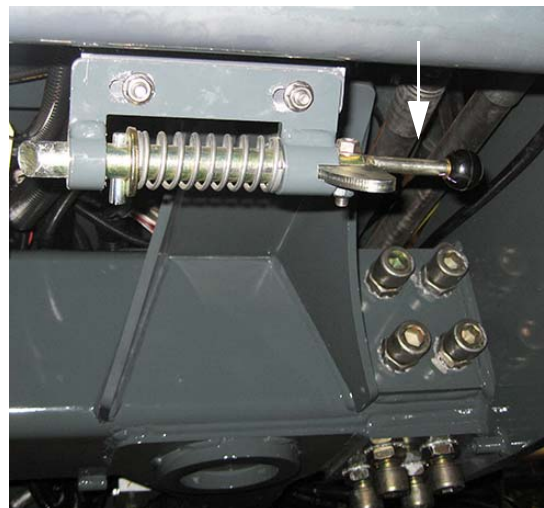

Front Fill Release Lever
(Located beneath front end of machine)
-Typical View

2. Lower the Front Fill Assembly.

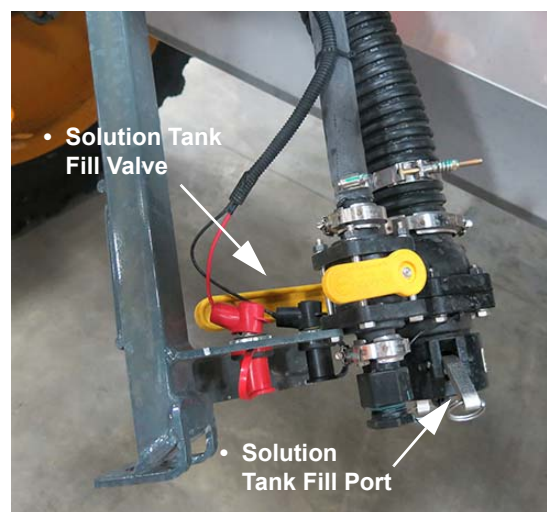

Front Fill Assembly
(Lowered position shown)
-Typical View

3. Remove fill port cap and connect solution supply to the Solution Tank Fill Port.
4. Rotate Solution Tank Fill Valve to the OPEN position and fill tank to desired level.

NOTE: Two power ports (located near the front fill assembly) are provided for chemical pump connection.

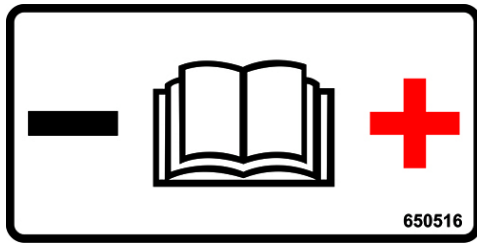

Power Ports
(Located near front fill assembly)
-Typical View

5. **When finished filling the tank**, close the Solution Tank Fill Valve.
6. Remove solution supply from the Solution Tank Fill Port.
7. Reinstall fill port cap.
8. Raise the Front Fill Assembly to stored position, ensuring it “clicks” into locked position.

Filling the Rinse Tank

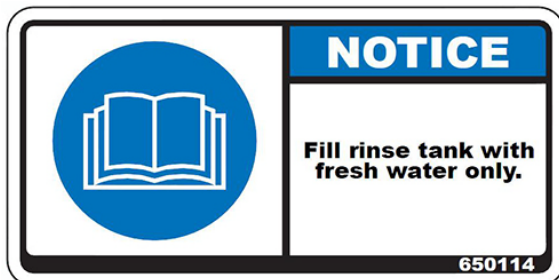

NOTE: Rinse Tank Capacity = 100 gallons (378L).

1. Pull the Front Fill Release Lever (located beneath front end of machine) OUT

(toward operator) to unlock the Front Fill Assembly.

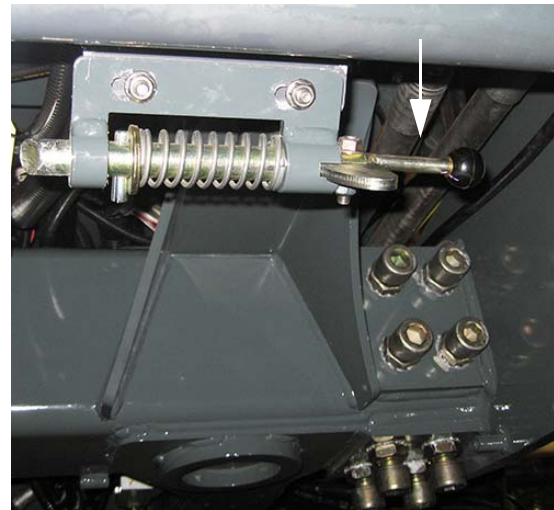

Front Fill Release Lever
(Located beneath front end of machine)
-Typical View

2. Lower the Front Fill Assembly.



Front Fill Assembly
(Lowered position shown)
-Typical View

3. Remove fill port cap from the Rinse Tank Fill Port.
4. Connect operator-supplied connection to the Rinse Tank Fill Port.

5. Rotate Rinse Tank Fill Valve to the OPEN position and fill tank to desired level.
6. **When finished filling the tank**, close the Rinse Tank Fill Valve.
7. Remove operator-supplied connection from the Rinse Tank Fill Port.
8. Reinstall the fill port cap.
9. Raise the Front Fill Assembly to the stored position, ensuring it “clicks” into locked position.

Rinsing the Front Fill

1. Remove Solution Tank Fill Port cap.
2. Attach fresh water supply connection to Solution Tank Fill Port.
3. Turn fresh water supply ON.
4. Rotate the Solution Tank Fill Valve in the OPEN position.
5. **When rinsing is complete**, turn fresh water supply OFF.
6. Close the Solution Tank Fill Valve.
7. Remove fresh water supply connection from the Solution Tank Fill Port and re-install cap.

Side Fill

NOTE: Engage parking brake before operating the side fill.

Filling the Solution Tank - Inductor Operation (Tanks 1 and 2)

Inductor Assembly Components

- (A) - Side Fill Valve
- (B) - Rinse Supply Valve
- (C) - Chemical Inductor Valve
- (D) - Transfer Pump
- (E) - Swirl Valve
- (F) - Chemical Inductor Tank
- (G) - Single Product Fill Port - Tank 1
- (H) - Single Product Fill Valve - Tank 1
- (I) - Dual Product Fill Port - Tank 2
- (J) - Dual Product Fill Valve - Tank 2
- (K) - Pump Speed Switch
- (L) - Raise/Lower Switch
- (M) - Pump Activation Lever
- (N) - Power Ports

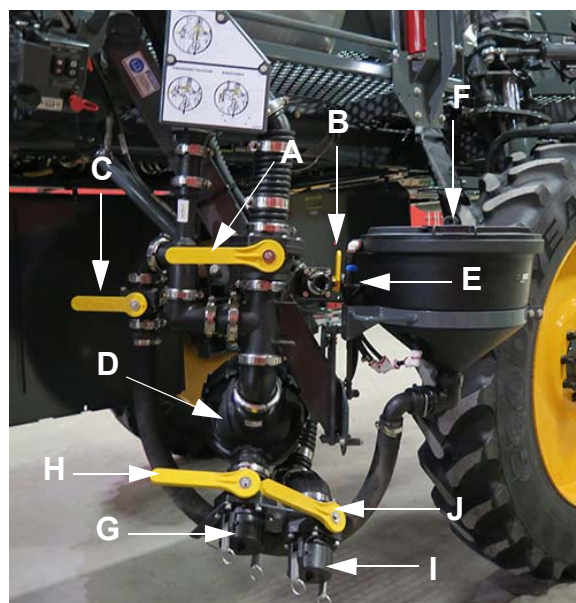

Inductor Assembly
-Typical View

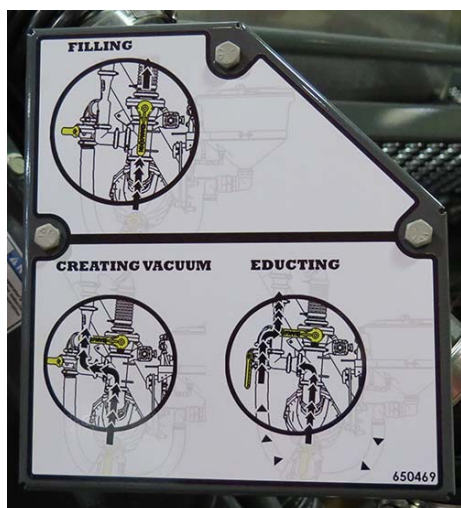

Side Fill Operation Label
(Located near side fill assembly)
-Typical View

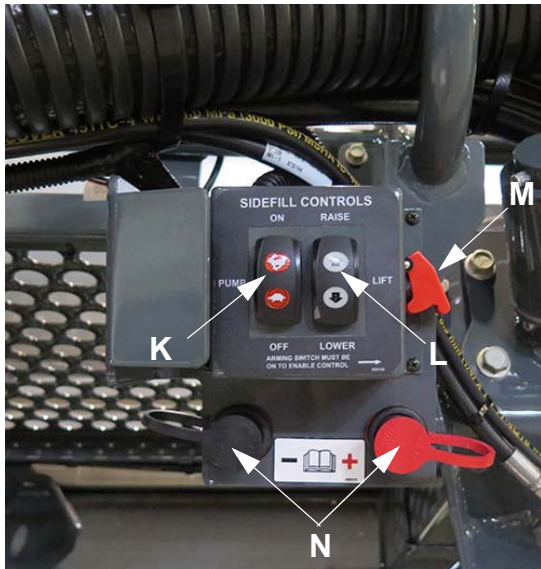

Side Fill Control Panel
-Typical View

NOTE: Two power ports (N) are provided for chemical pump connection.

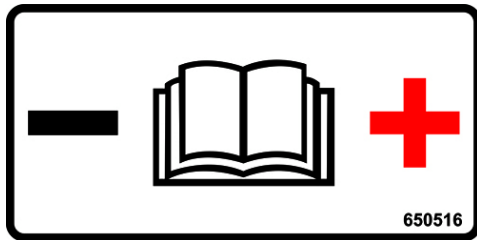

1. Engage the parking brake.
2. Start the engine.
3. Lift the Pump Activation Lever (M) UP.
4. Lower the Inductor Assembly by pressing the Raise/Lower Switch (L) in the DOWN (Lower) position.
5. Press the Pump Speed Switch (K) in the UP (On) position ONCE to activate the Transfer Pump.
6. Press and hold the Pump Speed Switch UP to increase speed or DOWN to decrease speed.

NOTE: Engine speed automatically increases to 1500 RPM at maximum pump speed.

NOTE: Always match pump speed to available supply to avoid pump damage.

NOTE: Whether filling with the Transfer Pump or an off-site pump, ensure the Transfer Pump is running.

7. Press and hold the Pump Speed Switch in the DOWN (Off) position when filling is complete.
8. Push the Pump Activation Lever DOWN.

NOTE: The following procedures are the same for either a sprayer-mounted transfer pump or a nurse tank pump.

** Single or Dual Product*

Fill Water Only

- Fill Port (G) - **CONNECTED**
- Fill Valve (H) - **OPEN**
- Chemical Inductor Valve (C) - **CLOSED**
- Side Fill Valve (A) - **OPEN**
- Swirl Valve (E) - **CLOSED**

Fill Water/Induct Chemical

- Fill Port (G or I*) - **CONNECTED**
- Fill Valve (H or J*) - **OPEN**
- Side Fill Valve (A) - **CLOSED**
- Chemical Inductor Valve (C) - **OPEN** (after flow is established)

Fill Water/Induct Dry Chemical

- Fill Port (G) - **CONNECTED**
- Fill Valve (H) - **OPEN**
- Side Fill Valve (A) - **CLOSED**
- Swirl Valve (E) - **OPEN**

NOTE: Allow water to fill chemical tank approximately 3 inches (7.6 cm) before adding dry chemical. Add dry chemical with the Swirl Valve (E) OPEN. Open the Chemical Inductor (E) after dry chemical has been added.

Fill Rinse Tank

- Rinse Supply Valve (B) - **OPEN**

Rinse Inductor Tank

- Swirl Valve (E) - **OPEN**

NOTE: Before raising the Inductor Assembly, the Chemical Inductor Tank must be in the LOCKED position.

Rinsing the Side Fill

1. Remove Fill Port cap.
2. Attach fresh water supply connection to Fill Port.

3. Turn fresh water supply ON.
4. Rotate the Fill Valve (H or J*) in the OPEN position.
5. Rotate the Side Fill Valve (A) in the OPEN position.
6. **When rinsing is complete**, turn fresh water supply OFF.
7. Close the Fill Valve and Side Fill Valve.
8. Remove fresh water supply connection from Fill Port and reinstall cap.

Solution Tank Sight Gauge

A dual Solution Tank Sight Gauge is located behind the rear left-hand side of cab to visually check solution level in both sides of the tank at all times.



Dual Solution Tank Sight Gauge
(Located behind the rear
left-hand side of cab)
-Typical View

DRAINING YOUR SOLUTION TANK - DUAL PRODUCT

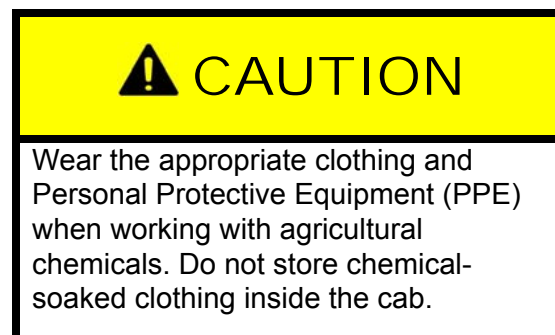

To Drain the Solution Tank

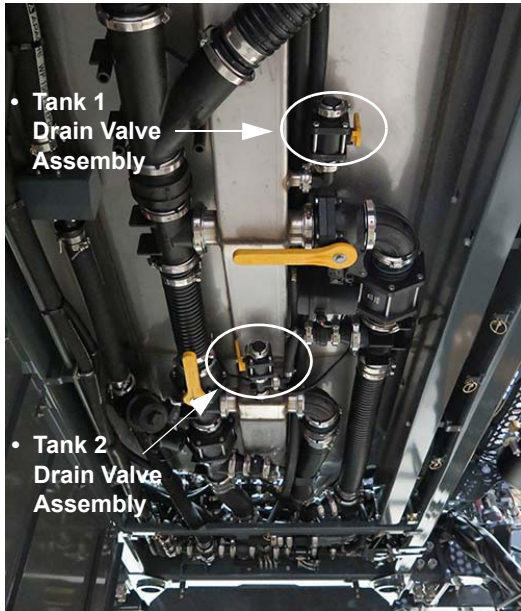

Solution Tank Drain Valve Assemblies (2)
(Located beneath the solution tank on underside of machine)
-Typical View

* View looking towards rear of machine

NOTICE

When draining large volumes from the solution tank, it is recommended to pump off with the solution pump through the front quick coupler.

1. Loosen the metal flange clamp and remove Drain Valve Plug (located on the end of the Solution Tank Drain Valve Assembly of the tank side you desire to drain) and set aside.

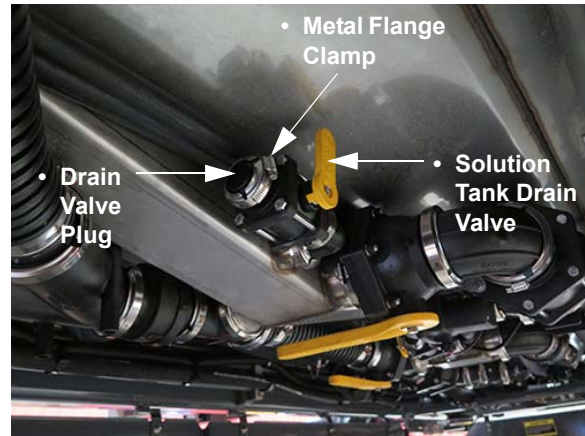

Solution Tank Drain Valve Assembly
(Located beneath the solution tank on underside of machine)
-Typical View

* Tank 1 drain valve assembly shown

2. Connect an operator-supplied hose to the tank drain outlet (where Drain Valve Plug was previously removed).
3. Turn the Solution Tank Drain Valve in the OPEN (counter-clockwise) position and allow solution to drain into an appropriate container for storage.

NOTE: Always ensure that storage containers and clearly marked with what type of chemical is being stored.

4. **When finished draining the solution tank**, turn the Solution Tank Drain Valve in the CLOSED (clockwise) position.
5. Remove hose from the tank drain outlet.
6. Reinstall Drain Valve Plug and tighten metal flange clamp.
7. Repeat Steps 1-6 to drain solution from opposite side of tank.

APPLICATION - DUAL PRODUCT

It is important to apply chemicals as recommended by the manufacturer. In order to do so, the spray system console must be properly calibrated.

NOTE: Refer to the spray system console manufacturer's operation manual for calibration instructions.

Determine the speed in which the sprayer will travel when applying chemicals. To select the best speed, consider the lay of the land, condition of the soil, type of crop, height of crop, etc.

Remember that the performance of the nozzles (spray tips) and spray system are dependent on the performance of the operator. If the spray system is operated within set parameters of the nozzle type and spray system console, you will see greater success with your application. Operating the machine one or two miles per hour (1.6 to 3.2 km/h) faster or slower than intended can greatly change the pressure and droplet size.

Select nozzle spacing (distance between each nozzle on the spray boom) that is best suited for the intended spray application. For recommendation in determining nozzle spacing and height of the boom, visit www.teejet.com for further information.

There are various types and sizes of nozzles. Select and install the appropriate nozzle best suited for the intended spray application. The type of nozzle will depend on the product being applied and the type of crop that it is being used on. The size of nozzles selected will be based on the speed in which the machine will travel, nozzle spacing, desired droplet size, and the number of gallons per acre (GPA)/liters per hectare (l/ha) that will be applied.

Nozzle Selection

There are several things to consider when selecting the correct nozzle type for the intended spray application. Whatever your personal preference is, ensure that the nozzle complies with the chemical manufacturer's standards for spray control and also any environmental standards for your region.

NOTE: Certain regions may have restrictions on drift control.

Once you have selected the type of nozzle, you must choose the size of the nozzle. There are three main things to consider when choosing a nozzle size:

1. Recommendation of GPA (l/ha).
2. The speed in which you intend to travel when applying chemical and nozzle spacing (distance between nozzles).
3. Spray Tip size (refer to the following example on how to select a proper tip size).

The following Application Rate Chart provides tabulations based on spraying water. When spraying liquids other than water, you will need to use a conversion factor to configure the appropriate application rates.

Example of how to choose the proper nozzle:

Joe is spraying 28% nitrogen. The chemical manufacturer recommends that the chemical be applied at 20 gallons per acre (GPA)/187 liters per hectare (l/ha). Joe knows that he can run his sprayer at 10 mph (16 km/h) across the field. He has 20-inch (50 cm) nozzle spacing on his booms. Joe has narrowed his tip search to flat spray tips.

Use the following conversion formula:

- **20 GPA (187 l/ha) (liquid other than water) x 1.13 (conversion factor) = 22.6 GPA (211.3 l/ha) (water).**

Joe determined that he needs an application rate of 22.6 GPA (211.3 l/ha) to select the correct nozzle to apply 28% nitrogen at 20 GPA (187 l/ha).

To determine which nozzle is better for his intended use, Joe needs to figure out the gallons per minute (GPM)/liters per minute (l/min) each nozzle needs to spray.



| | |
|--------------|---|
| GPM = | $\frac{\text{GPA} \times \text{MPH} \times \text{Nozzle Spacing}}{5940 \text{ (Constant)}}$ |
|--------------|---|

| | |
|----------------|--|
| l/min = | $\frac{\text{l/ha} \times \text{km/h} \times \text{Nozzle Spacing}}{60,000}$ |
|----------------|--|

Examples:

| | | | |
|--------------|---|-----------------------|--------------------------------|
| GPM = | $\frac{22.6 \times 10 \times 20}{5940}$ | $= \frac{4520}{5940}$ | = 0.76 GPM (per nozzle) |
|--------------|---|-----------------------|--------------------------------|

| | | | |
|----------------|--|---------------------------|----------------------------------|
| l/min = | $\frac{211.3 \times 16 \times 50}{60,000}$ | $= \frac{169040}{60,000}$ | = 2.82 l/min (per nozzle) |
|----------------|--|---------------------------|----------------------------------|

| English to Metric Conversion |
|--|
| <ul style="list-style-type: none"> • Gallons per Acre (GPA) x 9.354 = Liters per Hectare (l/ha) • Gallons per Minute (GPM) x 3.785 = Liters per Minute (l/min) |
| Metric to English Conversion |
| <ul style="list-style-type: none"> • Liters per Hectare (l/ha) x .1069 = Gallons per Acre (GPA) • Liters per Minute (l/min) x .26 = Gallons per Minute (GPM) |

NOTE: Always double check your application rates. The following tabulations are based on spraying water at 70° F./21° C.

SECTION 8 –
DUAL PRODUCT SPRAY SYSTEMS



| Standard Application Rate Chart | | | | | | | | | | | | |
|---------------------------------|-----------------------|---------------------|--------------------------|---|-------|-------|--------|--------|--------|--------|--------|--------|
| | | | | Gallons per Acre (GPA) - 15" Nozzle Spacing | | | | | | | | |
| Tip Cap. | Liquid Pressure (PSI) | Cap. 1 Nozzle (GPM) | Cap. 1 Nozzle (Oz./Min.) | 4 mph | 6 mph | 8 mph | 10 mph | 12 mph | 14 mph | 16 mph | 18 mph | 20 mph |
| 01 | 15 | 0.061 | 7.8 | 6.0 | 4.0 | 3.0 | 2.4 | 2.0 | 1.7 | 1.5 | 1.3 | 1.2 |
| | 20 | 0.071 | 9.1 | 7.0 | 4.7 | 3.5 | 2.8 | 2.3 | 2.0 | 1.8 | 1.6 | 1.4 |
| | 30 | 0.087 | 11 | 8.6 | 5.7 | 4.3 | 3.4 | 2.9 | 2.5 | 2.2 | 1.9 | 1.7 |
| | 40 | 0.10 | 13 | 9.9 | 6.6 | 5.0 | 4.0 | 3.3 | 2.8 | 2.5 | 2.2 | 2.0 |
| | 50 | 0.11 | 14 | 10.9 | 7.3 | 5.4 | 4.4 | 3.6 | 3.1 | 2.7 | 2.4 | 2.2 |
| | 60 | 0.12 | 15 | 11.9 | 7.9 | 5.9 | 4.8 | 4.0 | 3.4 | 3.0 | 2.6 | 2.4 |
| | 75 | 0.14 | 18 | 13.9 | 9.2 | 6.9 | 5.5 | 4.6 | 4.0 | 3.5 | 3.1 | 2.8 |
| | 90 | 0.15 | 19 | 14.9 | 9.9 | 7.4 | 5.9 | 5.0 | 4.2 | 3.7 | 3.3 | 3.0 |
| 015 | 15 | 0.092 | 12 | 9.1 | 6.1 | 4.6 | 3.6 | 3.0 | 2.6 | 2.3 | 2.0 | 1.8 |
| | 20 | 0.11 | 14 | 10.9 | 7.3 | 5.4 | 4.4 | 3.6 | 3.1 | 2.7 | 2.4 | 2.2 |
| | 30 | 0.13 | 17 | 12.9 | 8.6 | 6.4 | 5.1 | 4.3 | 3.7 | 3.2 | 2.9 | 2.6 |
| | 40 | 0.15 | 19 | 14.9 | 9.9 | 7.4 | 5.9 | 5.0 | 4.2 | 3.7 | 3.3 | 3.0 |
| | 50 | 0.17 | 22 | 16.8 | 11.2 | 8.4 | 6.7 | 5.6 | 4.8 | 4.2 | 3.7 | 3.4 |
| | 60 | 0.18 | 23 | 17.8 | 11.9 | 8.9 | 7.1 | 5.9 | 5.1 | 4.5 | 4.0 | 3.6 |
| | 75 | 0.21 | 27 | 21 | 13.9 | 10.4 | 8.3 | 6.9 | 5.9 | 5.2 | 4.6 | 4.2 |
| | 90 | 0.23 | 29 | 23 | 15.2 | 11.4 | 9.1 | 7.6 | 6.5 | 5.7 | 5.1 | 4.6 |
| 02 | 15 | 0.12 | 15 | 11.9 | 7.9 | 5.9 | 4.8 | 4.0 | 3.4 | 3.0 | 2.6 | 2.4 |
| | 20 | 0.14 | 18 | 13.9 | 9.2 | 6.9 | 5.5 | 4.6 | 4.0 | 3.5 | 3.1 | 2.8 |
| | 30 | 0.17 | 22 | 16.8 | 11.2 | 8.4 | 6.7 | 5.6 | 4.8 | 4.2 | 3.7 | 3.4 |
| | 40 | 0.20 | 26 | 19.8 | 13.2 | 9.9 | 7.9 | 6.6 | 5.7 | 5.0 | 4.4 | 4.0 |
| | 50 | 0.22 | 28 | 22 | 14.5 | 10.9 | 8.7 | 7.3 | 6.2 | 5.4 | 4.8 | 4.4 |
| | 60 | 0.24 | 31 | 24 | 15.8 | 11.9 | 9.5 | 7.9 | 6.8 | 5.9 | 5.3 | 4.8 |
| | 75 | 0.27 | 35 | 27 | 17.8 | 13.4 | 10.7 | 8.9 | 7.6 | 6.7 | 5.9 | 5.3 |
| | 90 | 0.30 | 38 | 30 | 19.8 | 14.9 | 11.9 | 9.9 | 8.5 | 7.4 | 6.6 | 5.9 |
| 025 | 15 | 0.15 | 19 | 14.9 | 9.9 | 7.4 | 5.9 | 5.0 | 4.2 | 3.7 | 3.3 | 3.0 |
| | 20 | 0.18 | 23 | 17.8 | 11.9 | 8.9 | 7.1 | 5.9 | 5.1 | 4.5 | 4.0 | 3.6 |
| | 30 | 0.22 | 28 | 22 | 14.5 | 10.9 | 8.7 | 7.3 | 6.2 | 5.4 | 4.8 | 4.4 |
| | 40 | 0.25 | 32 | 25 | 16.5 | 12.4 | 9.9 | 8.3 | 7.1 | 6.2 | 5.5 | 5.0 |
| | 50 | 0.28 | 36 | 28 | 18.5 | 13.9 | 11.1 | 9.2 | 7.9 | 6.9 | 6.2 | 5.5 |
| | 60 | 0.31 | 40 | 31 | 20 | 15.3 | 12.3 | 10.2 | 8.8 | 7.7 | 6.8 | 6.1 |
| | 75 | 0.34 | 44 | 34 | 22 | 16.8 | 13.5 | 11.2 | 9.6 | 8.4 | 7.5 | 6.7 |
| | 90 | 0.38 | 49 | 38 | 25 | 18.8 | 15.0 | 12.5 | 10.7 | 9.4 | 8.4 | 7.5 |



SECTION 8 -
DUAL PRODUCT SPRAY SYSTEMS

| | | | | | | | | | | | | |
|----|----|------|-----|------|------|------|------|------|------|------|------|------|
| 03 | 15 | 0.18 | 23 | 17.8 | 11.9 | 8.9 | 7.1 | 5.9 | 5.1 | 4.5 | 4.0 | 3.6 |
| | 20 | 0.21 | 27 | 21 | 13.9 | 10.4 | 8.3 | 6.9 | 5.9 | 5.2 | 4.6 | 4.2 |
| | 30 | 0.26 | 33 | 26 | 17.2 | 12.9 | 10.3 | 8.6 | 7.4 | 6.4 | 5.7 | 5.1 |
| | 40 | 0.30 | 38 | 30 | 19.8 | 14.9 | 11.9 | 9.9 | 8.5 | 7.4 | 6.6 | 5.9 |
| | 50 | 0.34 | 44 | 34 | 22 | 16.8 | 13.5 | 11.2 | 9.6 | 8.4 | 7.5 | 6.7 |
| | 60 | 0.37 | 47 | 37 | 24 | 18.3 | 14.7 | 12.2 | 10.5 | 9.2 | 8.1 | 7.3 |
| | 75 | 0.41 | 52 | 41 | 27 | 20 | 16.2 | 13.5 | 11.6 | 10.1 | 9.0 | 8.1 |
| | 90 | 0.45 | 58 | 45 | 30 | 22 | 17.8 | 14.9 | 12.7 | 11.1 | 9.9 | 8.9 |
| 04 | 15 | 0.24 | 31 | 24 | 15.8 | 11.9 | 9.5 | 7.9 | 6.8 | 5.9 | 5.3 | 4.8 |
| | 20 | 0.28 | 36 | 28 | 18.5 | 13.9 | 11.1 | 9.2 | 7.9 | 6.9 | 6.2 | 5.5 |
| | 30 | 0.35 | 45 | 35 | 23 | 17.3 | 13.9 | 11.6 | 9.9 | 8.7 | 7.7 | 6.9 |
| | 40 | 0.40 | 51 | 40 | 26 | 19.8 | 15.8 | 13.2 | 11.3 | 9.9 | 8.8 | 7.9 |
| | 50 | 0.45 | 58 | 45 | 30 | 22 | 17.8 | 14.9 | 12.7 | 11.1 | 9.9 | 8.9 |
| | 60 | 0.49 | 63 | 49 | 32 | 24 | 19.4 | 16.2 | 13.9 | 12.1 | 10.8 | 9.7 |
| | 75 | 0.55 | 70 | 54 | 36 | 27 | 22 | 18.2 | 15.6 | 13.6 | 12.1 | 10.9 |
| | 90 | 0.60 | 77 | 59 | 40 | 30 | 24 | 19.8 | 17.0 | 14.9 | 13.2 | 11.9 |
| 05 | 15 | 0.31 | 40 | 31 | 20 | 15.3 | 12.3 | 10.2 | 8.8 | 7.7 | 6.8 | 6.1 |
| | 20 | 0.35 | 45 | 35 | 23 | 17.3 | 13.9 | 11.6 | 9.9 | 8.7 | 7.7 | 6.9 |
| | 30 | 0.43 | 55 | 43 | 28 | 21 | 17.0 | 14.2 | 12.2 | 10.6 | 9.5 | 8.5 |
| | 40 | 0.50 | 64 | 50 | 33 | 25 | 19.8 | 16.5 | 14.1 | 12.4 | 11.0 | 9.9 |
| | 50 | 0.56 | 72 | 55 | 37 | 28 | 22 | 18.5 | 15.8 | 13.9 | 12.3 | 11.1 |
| | 60 | 0.61 | 78 | 60 | 40 | 30 | 24 | 20 | 17.3 | 15.1 | 13.4 | 12.1 |
| | 75 | 0.68 | 87 | 67 | 45 | 34 | 27 | 22 | 19.2 | 16.8 | 15.0 | 13.5 |
| | 90 | 0.75 | 96 | 74 | 50 | 37 | 30 | 25 | 21 | 18.6 | 16.5 | 14.9 |
| 06 | 15 | 0.37 | 47 | 37 | 24 | 18.3 | 14.7 | 12.2 | 10.5 | 9.2 | 8.1 | 7.3 |
| | 20 | 0.42 | 54 | 42 | 28 | 21 | 16.6 | 13.9 | 11.9 | 10.4 | 9.2 | 8.3 |
| | 30 | 0.52 | 67 | 51 | 34 | 26 | 21 | 17.2 | 14.7 | 12.9 | 11.4 | 10.3 |
| | 40 | 0.60 | 77 | 59 | 40 | 30 | 24 | 19.8 | 17.0 | 14.9 | 13.2 | 11.9 |
| | 50 | 0.67 | 86 | 66 | 44 | 33 | 27 | 22 | 19.0 | 16.6 | 14.7 | 13.3 |
| | 60 | 0.73 | 93 | 72 | 48 | 36 | 29 | 24 | 21 | 18.1 | 16.1 | 14.5 |
| | 75 | 0.82 | 105 | 81 | 54 | 41 | 32 | 27 | 23 | 20 | 18.0 | 16.2 |
| | 90 | 0.90 | 115 | 89 | 59 | 45 | 36 | 30 | 25 | 22 | 19.8 | 17.8 |
| 08 | 15 | 0.49 | 63 | 49 | 32 | 24 | 19.4 | 16.2 | 13.9 | 12.1 | 10.8 | 9.7 |
| | 20 | 0.57 | 73 | 56 | 38 | 28 | 23 | 18.8 | 16.1 | 14.1 | 12.5 | 11.3 |
| | 30 | 0.69 | 88 | 68 | 46 | 34 | 27 | 23 | 19.5 | 17.1 | 15.2 | 13.7 |
| | 40 | 0.80 | 102 | 79 | 53 | 40 | 32 | 26 | 23 | 19.8 | 17.6 | 15.8 |
| | 50 | 0.89 | 114 | 88 | 59 | 44 | 35 | 29 | 25 | 22 | 19.6 | 17.6 |
| | 60 | 0.98 | 125 | 97 | 65 | 49 | 39 | 32 | 28 | 24 | 22 | 19.4 |
| | 75 | 1.10 | 141 | 109 | 73 | 54 | 44 | 36 | 31 | 27 | 24 | 22 |
| | 90 | 1.20 | 154 | 119 | 79 | 59 | 48 | 40 | 34 | 30 | 26 | 24 |
| 10 | 15 | 0.61 | 78 | 60 | 40 | 30 | 24 | 20 | 17.3 | 15.1 | 13.4 | 12.1 |
| | 20 | 0.71 | 91 | 70 | 47 | 35 | 28 | 23 | 20 | 17.6 | 15.6 | 14.1 |
| | 30 | 0.87 | 111 | 86 | 57 | 43 | 34 | 29 | 25 | 22 | 19.1 | 17.2 |
| | 40 | 1.00 | 128 | 99 | 66 | 50 | 40 | 33 | 28 | 25 | 22 | 19.8 |
| | 50 | 1.12 | 143 | 111 | 74 | 55 | 44 | 37 | 32 | 28 | 25 | 22 |
| | 60 | 1.22 | 156 | 121 | 81 | 60 | 48 | 40 | 35 | 30 | 27 | 24 |
| | 75 | 1.37 | 175 | 136 | 90 | 68 | 54 | 45 | 39 | 34 | 30 | 27 |
| | 90 | 1.50 | 192 | 149 | 99 | 74 | 59 | 50 | 42 | 37 | 33 | 30 |
| 15 | 15 | 0.92 | 118 | 91 | 61 | 46 | 36 | 30 | 26 | 23 | 20 | 18.2 |
| | 20 | 1.06 | 136 | 105 | 70 | 52 | 42 | 35 | 30 | 26 | 23 | 21 |
| | 30 | 1.30 | 166 | 129 | 86 | 64 | 51 | 43 | 37 | 32 | 29 | 26 |
| | 40 | 1.50 | 192 | 149 | 99 | 74 | 59 | 50 | 42 | 37 | 33 | 30 |
| | 50 | 1.68 | 215 | 166 | 111 | 83 | 67 | 55 | 48 | 42 | 37 | 33 |
| | 60 | 1.84 | 236 | 182 | 121 | 91 | 73 | 61 | 52 | 46 | 40 | 36 |
| | 75 | 2.05 | 262 | 203 | 135 | 101 | 81 | 68 | 58 | 51 | 45 | 41 |
| | 90 | 2.25 | 288 | 223 | 149 | 111 | 89 | 74 | 64 | 56 | 50 | 45 |

SECTION 8 -
DUAL PRODUCT SPRAY SYSTEMS



| | | | | | | | | | | | | |
|----|----|------|-----|-----|-----|-----|-----|----|----|----|----|----|
| 20 | 15 | 1.22 | 156 | 121 | 81 | 60 | 48 | 40 | 35 | 30 | 27 | 24 |
| | 20 | 1.41 | 180 | 140 | 93 | 70 | 56 | 47 | 40 | 35 | 31 | 28 |
| | 30 | 1.73 | 221 | 171 | 114 | 86 | 69 | 57 | 49 | 43 | 38 | 34 |
| | 40 | 2.00 | 256 | 198 | 132 | 99 | 79 | 66 | 57 | 50 | 44 | 40 |
| | 50 | 2.24 | 287 | 222 | 148 | 111 | 89 | 74 | 63 | 55 | 49 | 44 |
| | 60 | 2.45 | 314 | 243 | 162 | 121 | 97 | 81 | 69 | 61 | 54 | 49 |
| | 75 | 2.74 | 351 | 271 | 181 | 136 | 109 | 90 | 78 | 68 | 60 | 54 |
| | 90 | 3.00 | 384 | 297 | 198 | 149 | 119 | 99 | 85 | 74 | 66 | 59 |



| Metric Application Rate Chart | | | | | | | | | | | | | |
|-------------------------------|---------------------|-----------------------|--|--------|--------|---------|---------|---------|---------|---------|---------|---------|---------|
| | | | Liters per Hectare (l/ha) - 40 cm Nozzle Spacing | | | | | | | | | | |
| Tip Cap. | Liquid Press. (Bar) | Cap. 1 Nozzle (l/min) | 4 km/h | 6 km/h | 8 km/h | 10 km/h | 12 km/h | 14 km/h | 16 km/h | 18 km/h | 20 km/h | 25 km/h | 30 km/h |
| 01 | 1.0 | 0.23 | 86.3 | 57.5 | 43.1 | 34.5 | 28.8 | 24.6 | 21.6 | 19.2 | 17.3 | 13.8 | 11.5 |
| | 1.5 | 0.28 | 105 | 70.0 | 52.5 | 42.0 | 35.0 | 30.0 | 26.3 | 23.3 | 21.0 | 16.8 | 14.0 |
| | 2.0 | 0.32 | 120 | 80.0 | 60.0 | 48.0 | 40.0 | 34.3 | 30.0 | 26.7 | 24.0 | 19.2 | 16.0 |
| | 3.0 | 0.39 | 146 | 97.5 | 73.1 | 58.5 | 48.8 | 41.8 | 36.6 | 32.5 | 29.3 | 23.4 | 19.5 |
| | 4.0 | 0.45 | 169 | 113 | 84.4 | 67.5 | 56.3 | 48.2 | 42.2 | 37.5 | 33.8 | 27.0 | 22.5 |
| | 5.0 | 0.50 | 188 | 125 | 93.8 | 75.0 | 62.5 | 53.6 | 46.9 | 41.7 | 37.5 | 30.0 | 25.0 |
| | 6.0 | 0.55 | 206 | 138 | 103 | 82.5 | 68.8 | 58.9 | 51.6 | 45.8 | 41.3 | 33.0 | 27.5 |
| | 7.0 | 0.60 | 225 | 150 | 113 | 90.0 | 75.0 | 64.3 | 56.3 | 50.0 | 45.0 | 36.0 | 30.0 |
| 015 | 1.0 | 0.34 | 128 | 85 | 63.8 | 51.0 | 42.5 | 36.4 | 31.9 | 28.3 | 25.5 | 20.4 | 17.0 |
| | 1.5 | 0.42 | 158 | 105 | 78.8 | 63.0 | 52.5 | 45.0 | 39.4 | 35.0 | 31.5 | 25.2 | 21.0 |
| | 2.0 | 0.48 | 180 | 120 | 90.0 | 72.0 | 60.0 | 51.4 | 45.0 | 40.0 | 36.0 | 28.8 | 24.0 |
| | 3.0 | 0.59 | 221 | 148 | 111 | 88.5 | 73.8 | 63.2 | 55.3 | 49.2 | 44.3 | 35.4 | 29.5 |
| | 4.0 | 0.68 | 255 | 170 | 128 | 102 | 85.0 | 72.9 | 63.8 | 56.7 | 51.0 | 40.8 | 34.0 |
| | 5.0 | 0.76 | 285 | 190 | 143 | 114 | 95.0 | 81.4 | 71.3 | 63.3 | 57.0 | 45.6 | 38.0 |
| | 6.0 | 0.83 | 311 | 208 | 156 | 125 | 104 | 88.9 | 77.8 | 69.2 | 62.3 | 49.8 | 41.5 |
| | 7.0 | 0.90 | 338 | 225 | 169 | 135 | 113 | 96.4 | 84.4 | 75.0 | 67.5 | 54.0 | 45.0 |
| 02 | 1.0 | 0.46 | 173 | 115 | 86.3 | 69.0 | 57.5 | 49.3 | 43.1 | 38.3 | 34.5 | 27.6 | 23.0 |
| | 1.5 | 0.56 | 210 | 140 | 105 | 84.0 | 70.0 | 60.0 | 52.5 | 46.7 | 42.0 | 33.6 | 38.0 |
| | 2.0 | 0.65 | 244 | 163 | 122 | 97.5 | 81.3 | 69.6 | 60.9 | 54.2 | 48.8 | 39.0 | 32.5 |
| | 3.0 | 0.79 | 296 | 198 | 148 | 119 | 98.8 | 84.6 | 74.1 | 65.8 | 59.3 | 47.4 | 39.5 |
| | 4.0 | 0.91 | 341 | 228 | 171 | 137 | 114 | 97.5 | 85.3 | 75.8 | 68.3 | 54.6 | 45.5 |
| | 5.0 | 1.02 | 383 | 255 | 191 | 153 | 128 | 109 | 95.6 | 85.0 | 76.5 | 61.2 | 51.0 |
| | 6.0 | 1.12 | 420 | 280 | 210 | 168 | 140 | 120 | 105 | 93.3 | 84.0 | 67.2 | 56.0 |
| | 7.0 | 1.21 | 454 | 303 | 227 | 182 | 151 | 130 | 113 | 101 | 90.8 | 72.6 | 60.5 |
| 025 | 1.0 | 0.57 | 214 | 143 | 107 | 85.5 | 71.3 | 61.1 | 53.4 | 47.5 | 42.8 | 34.2 | 28.5 |
| | 1.5 | 0.70 | 263 | 175 | 131 | 105 | 87.5 | 75.0 | 65.6 | 58.3 | 52.5 | 42.0 | 35.0 |
| | 2.0 | 0.81 | 304 | 203 | 152 | 122 | 101 | 86.8 | 75.9 | 67.5 | 60.8 | 48.6 | 40.5 |
| | 3.0 | 0.99 | 371 | 248 | 186 | 149 | 124 | 106 | 92.8 | 82.5 | 74.3 | 59.4 | 49.5 |
| | 4.0 | 1.14 | 428 | 285 | 214 | 171 | 143 | 122 | 107 | 95.0 | 85.5 | 68.4 | 57.0 |
| | 5.0 | 1.28 | 480 | 320 | 240 | 192 | 160 | 137 | 120 | 107 | 96.0 | 76.8 | 64.0 |
| | 6.0 | 1.40 | 525 | 350 | 263 | 210 | 175 | 150 | 131 | 117 | 105 | 84.0 | 70.0 |
| | 7.0 | 1.51 | 566 | 378 | 283 | 227 | 189 | 162 | 142 | 126 | 113 | 90.6 | 75.5 |

SECTION 8 –
DUAL PRODUCT SPRAY SYSTEMS



| | | | | | | | | | | | | | |
|----|-----|------|------|------|------|------|------|------|------|------|------|------|------|
| 03 | 1.0 | 0.68 | 255 | 170 | 128 | 102 | 85 | 72.9 | 63.8 | 56.7 | 51.0 | 40.8 | 34.0 |
| | 1.5 | 0.83 | 311 | 208 | 156 | 125 | 104 | 88.9 | 77.8 | 69.2 | 62.3 | 49.8 | 41.5 |
| | 2.0 | 0.96 | 360 | 240 | 180 | 144 | 120 | 103 | 90.0 | 80.0 | 72.0 | 57.6 | 48.0 |
| | 3.0 | 1.18 | 443 | 295 | 221 | 177 | 148 | 126 | 111 | 98.3 | 88.5 | 70.8 | 59.0 |
| | 4.0 | 1.36 | 510 | 340 | 255 | 204 | 170 | 146 | 128 | 113 | 102 | 81.6 | 68.0 |
| | 5.0 | 1.52 | 570 | 380 | 285 | 228 | 190 | 163 | 143 | 127 | 114 | 91.2 | 76.0 |
| | 6.0 | 1.67 | 626 | 418 | 313 | 251 | 209 | 179 | 157 | 139 | 125 | 100 | 83.5 |
| | 7.0 | 1.80 | 675 | 450 | 338 | 270 | 225 | 193 | 169 | 150 | 135 | 108 | 90.0 |
| 04 | 1.0 | 0.91 | 341 | 228 | 171 | 137 | 114 | 97.5 | 85.3 | 75.8 | 68.3 | 54.6 | 45.5 |
| | 1.5 | 1.12 | 420 | 280 | 210 | 168 | 140 | 120 | 105 | 93.3 | 84.0 | 67.2 | 56.0 |
| | 2.0 | 1.29 | 484 | 323 | 242 | 194 | 161 | 138 | 121 | 108 | 96.8 | 77.4 | 64.5 |
| | 3.0 | 1.58 | 593 | 395 | 296 | 237 | 198 | 169 | 148 | 132 | 119 | 94.8 | 79.0 |
| | 4.0 | 1.82 | 683 | 455 | 341 | 273 | 228 | 195 | 171 | 152 | 137 | 109 | 91.0 |
| | 5.0 | 2.04 | 765 | 510 | 383 | 306 | 255 | 219 | 191 | 170 | 153 | 122 | 102 |
| | 6.0 | 2.23 | 836 | 558 | 418 | 335 | 279 | 239 | 209 | 186 | 167 | 134 | 112 |
| | 7.0 | 2.41 | 904 | 603 | 452 | 362 | 301 | 258 | 226 | 201 | 181 | 145 | 121 |
| 05 | 1.0 | 1.14 | 428 | 285 | 214 | 171 | 143 | 122 | 107 | 95 | 85.5 | 68.4 | 57.0 |
| | 1.5 | 1.39 | 521 | 348 | 261 | 209 | 174 | 149 | 130 | 116 | 104 | 83.4 | 69.5 |
| | 2.0 | 1.61 | 604 | 403 | 302 | 242 | 201 | 173 | 151 | 134 | 121 | 96.6 | 80.5 |
| | 3.0 | 1.97 | 739 | 493 | 369 | 296 | 246 | 211 | 185 | 164 | 148 | 118 | 98.5 |
| | 4.0 | 2.27 | 851 | 568 | 426 | 341 | 284 | 243 | 213 | 189 | 170 | 136 | 114 |
| | 5.0 | 2.54 | 953 | 635 | 476 | 381 | 318 | 272 | 238 | 212 | 191 | 152 | 127 |
| | 6.0 | 2.79 | 1046 | 698 | 523 | 419 | 349 | 299 | 262 | 233 | 209 | 167 | 140 |
| | 7.0 | 3.01 | 1129 | 753 | 564 | 452 | 376 | 323 | 282 | 251 | 226 | 181 | 151 |
| 06 | 1.0 | 1.37 | 514 | 343 | 257 | 206 | 171 | 147 | 128 | 114 | 103 | 82.2 | 68.5 |
| | 1.5 | 1.68 | 630 | 420 | 315 | 252 | 210 | 180 | 158 | 140 | 126 | 101 | 84.0 |
| | 2.0 | 1.94 | 728 | 485 | 364 | 291 | 243 | 208 | 182 | 162 | 146 | 116 | 97.0 |
| | 3.0 | 2.37 | 889 | 593 | 444 | 356 | 296 | 254 | 222 | 198 | 178 | 142 | 119 |
| | 4.0 | 2.74 | 1028 | 685 | 514 | 411 | 343 | 294 | 257 | 228 | 206 | 164 | 137 |
| | 5.0 | 3.06 | 1148 | 765 | 574 | 459 | 383 | 328 | 287 | 255 | 230 | 184 | 153 |
| | 6.0 | 3.35 | 1256 | 838 | 628 | 503 | 419 | 359 | 314 | 279 | 251 | 201 | 168 |
| | 7.0 | 3.62 | 1358 | 905 | 679 | 543 | 453 | 388 | 339 | 302 | 272 | 217 | 181 |
| 08 | 1.0 | 1.82 | 683 | 455 | 341 | 273 | 228 | 195 | 171 | 152 | 137 | 109 | 91 |
| | 1.5 | 2.23 | 836 | 558 | 418 | 335 | 279 | 239 | 209 | 186 | 167 | 134 | 112 |
| | 2.0 | 2.58 | 968 | 645 | 484 | 387 | 323 | 276 | 242 | 215 | 194 | 155 | 129 |
| | 3.0 | 3.16 | 1185 | 790 | 593 | 474 | 395 | 339 | 296 | 263 | 237 | 190 | 158 |
| | 4.0 | 3.65 | 1369 | 913 | 684 | 548 | 456 | 391 | 342 | 304 | 274 | 219 | 183 |
| | 5.0 | 4.08 | 1530 | 1020 | 765 | 612 | 510 | 437 | 383 | 340 | 306 | 245 | 204 |
| | 6.0 | 4.47 | 1676 | 1118 | 838 | 671 | 559 | 479 | 419 | 373 | 335 | 268 | 224 |
| | 7.0 | 4.83 | 1811 | 1208 | 906 | 725 | 604 | 518 | 453 | 403 | 362 | 290 | 242 |
| 10 | 1.0 | 2.28 | 855 | 570 | 428 | 342 | 285 | 244 | 214 | 190 | 171 | 137 | 114 |
| | 1.5 | 2.79 | 1046 | 698 | 523 | 419 | 349 | 299 | 262 | 233 | 209 | 167 | 140 |
| | 2.0 | 3.23 | 1211 | 808 | 606 | 485 | 404 | 346 | 303 | 269 | 242 | 194 | 162 |
| | 3.0 | 3.95 | 1481 | 988 | 741 | 593 | 494 | 423 | 370 | 329 | 296 | 237 | 198 |
| | 4.0 | 4.56 | 1710 | 1140 | 855 | 684 | 570 | 489 | 428 | 380 | 342 | 274 | 228 |
| | 5.0 | 5.10 | 1913 | 1275 | 956 | 765 | 638 | 546 | 478 | 425 | 383 | 306 | 255 |
| | 6.0 | 5.59 | 2096 | 1398 | 1048 | 839 | 699 | 599 | 524 | 466 | 419 | 335 | 280 |
| | 7.0 | 6.03 | 2261 | 1508 | 1131 | 905 | 754 | 646 | 565 | 503 | 452 | 362 | 302 |
| 15 | 1.0 | 3.42 | 1283 | 855 | 641 | 513 | 428 | 366 | 321 | 285 | 257 | 205 | 171 |
| | 1.5 | 4.19 | 1571 | 1048 | 786 | 629 | 524 | 449 | 393 | 349 | 314 | 251 | 210 |
| | 2.0 | 4.83 | 1811 | 1208 | 906 | 725 | 604 | 518 | 453 | 403 | 362 | 290 | 242 |
| | 3.0 | 5.92 | 2220 | 1480 | 1110 | 888 | 740 | 634 | 555 | 493 | 444 | 355 | 296 |
| | 4.0 | 6.84 | 2565 | 1710 | 1283 | 1026 | 855 | 733 | 641 | 570 | 513 | 410 | 342 |
| | 5.0 | 7.64 | 2865 | 1910 | 1433 | 1146 | 955 | 819 | 716 | 637 | 573 | 458 | 382 |
| | 6.0 | 8.37 | 3139 | 2093 | 1569 | 1256 | 1046 | 897 | 785 | 698 | 628 | 502 | 419 |
| | 7.0 | 9.04 | 3390 | 2260 | 1695 | 1356 | 1130 | 969 | 848 | 753 | 678 | 542 | 452 |

| | | | | | | | | | | | | | |
|----|-----|-------|------|------|------|------|------|------|------|------|-----|-----|-----|
| 20 | 1.0 | 4.56 | 1710 | 1140 | 855 | 684 | 570 | 489 | 428 | 380 | 342 | 274 | 228 |
| | 1.5 | 5.58 | 2093 | 1395 | 1046 | 837 | 698 | 598 | 523 | 465 | 419 | 335 | 279 |
| | 2.0 | 6.44 | 2415 | 1610 | 1208 | 966 | 805 | 690 | 604 | 537 | 483 | 386 | 322 |
| | 3.0 | 7.89 | 2959 | 1973 | 1479 | 1184 | 986 | 845 | 740 | 658 | 592 | 473 | 395 |
| | 4.0 | 9.11 | 3416 | 2278 | 1708 | 1367 | 1139 | 976 | 854 | 759 | 683 | 547 | 456 |
| | 5.0 | 10.19 | 3821 | 2548 | 1911 | 1529 | 1274 | 1092 | 955 | 849 | 764 | 611 | 510 |
| | 6.0 | 11.16 | 4185 | 2790 | 2093 | 1674 | 1395 | 1196 | 1046 | 930 | 837 | 670 | 558 |
| | 7.0 | 12.05 | 4519 | 3013 | 2259 | 1808 | 1506 | 1291 | 1130 | 1004 | 904 | 723 | 603 |

NOTE: The previous tabulations are based on 15-inch/40 cm nozzle spacing. Visit www.teejet.com for tabulations if choosing spacing other than 15"/40 cm.

Verifying Calibration

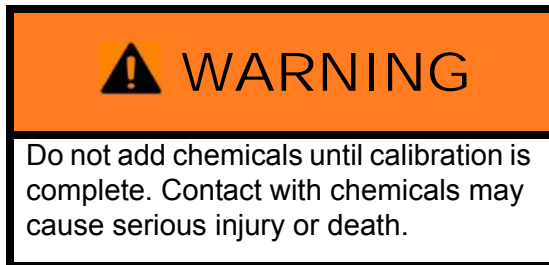

To test your system, fill the solution tank with clean water. **Do not add chemicals until calibration is complete.**

1. Engage the parking brake.
2. Start the engine.
3. Throttle the engine to operating speed.
4. Turn the spray system console ON.
5. Press the Field/Road Button (located on the Machine Display Home Page) and change the drive state of the machine to FIELD.
6. Press the Main Tank Valve Switch (located on the side console) in the UP (Open) position.
7. Press the Master Spray Switch (located on the Hydrostatic Drive Control Handle) in the ON position.
8. Press all Boom Solution Valve Switches (located on both Single and Dual Product Section Keypads) in the ON position. *Single Product Section Keypad (Sections 1-9) and Dual Product Section Keypad (Sections 10-14).*
9. **Primary System** - Press the Manual ("MAN") Rate Control Switch (located on the side console).
10. **Primary System** - Press the Pump Speed/Rate Switch (located on the side console) in the "+" position to increase flow.

11. **Secondary System** - Press and hold the Rate Control Button (located on the spray system console). Change to Manual mode ("MAN").
12. **Secondary System** - Press the Rate Bump Button (located on the spray system console) in the UP position to increase flow.
13. Ensure there are no leaks and that all nozzles are spraying a desirable pattern.
14. Continue spraying in the stationary position for at least 10 minutes for proper warm-up of the sprayer and system.

Once the sprayer has had an adequate warm-up period, you will need to perform a "self test" to simulate speed (although the machine will remain stationary).

NOTE: The following "self-test" steps require measuring flow at given pressure.

- Collect one nozzle's spray for one (1) minute in an adequately sized and marked container.
- Verify that the collection equals or is close to the GPM (l/min) for the nozzle, pressure, speed, GPA (l/ha), and spacing that you are using.

Also to ensure accuracy, you will need to verify the flow meter. To do so:

- Collect one nozzle's spray for one (1) minute and multiply it by the number of nozzles on the boom. This should equal the amount measured through the flow meter.

Calculating Spray Width

The spray section widths will need to be entered into the spray system console during initial set-up. No matter what the length of the

boom is or how many spray sections it has, the formula for calculating section widths are the same.

**Number of Nozzles x Nozzle Spacing
= Spray Section Width**

Example:

Section 2 of a 120-ft. boom with 15-inch (38 cm) nozzle spacing (10 spray nozzles).

**10 Nozzles x 15 (Nozzle Spacing)
= 150" (Section Width)**

**10 Nozzles x 38 (Nozzle Spacing)
= 380 cm (Section Width)**

Further Information

Refer to the spray system console manufacturer's operation manual for complete operating and calibrating instructions, troubleshooting tips, and safety precautions.



SECTION 9 – MAINTENANCE AND STORAGE



Hagie Manufacturing Company LLC
P.O. Box 273 • Clarion, IA 50525-0273
Hagiehelp.com

| LUBRICATION RECOMMENDATIONS | | | |
|-----------------------------|--|--|--|
| COMPONENT | GENERAL SPECIFICATION | RECOMMENDED LUBRICANT | RECOMMENDED SERVICE INTERVAL |
| Engine Oil | API CJ-4 15W-40 | JD Plus-50 II 15W40 (filled with JD Break-in Plus from factory) | Change between 100-500 hrs to JD Plus-50 II |
| Engine Coolant | ASTM D6210 Nitrite free | John Deere Cool Gard II EG 50/50 mix | 2000 Hours or 2 Years |
| Hydraulic Oil | ISO 11158, Type HM/HV, VG 46 | John Deere Hy-Gard™ | Oil Analysis Guidance or Change at 1000 Hours |
| Planetary/Hub Drives | CAT TO-4 OR CAT TO-4M RATED LUBRICANTS | Mobiltrans AST gear oil – all season transmission | Oil Analysis Guidance or 250 hours/Yearly |
| Greased Points | NLGI, EP, ISO 220 | SD Polyurea | Daily |

PLEASE CONSULT MANUAL FOR FURTHER DETAILS

650558

NOTICE

Remove all chemical residue from the work area before performing service/ maintenance.

NOTICE

Pump repair and replacement should be performed by qualified service personnel only. Replace with properly rated components. Refer to your parts manual for further information.

NOTICE

Refer to your parts manual when replacing hydraulic hoses to ensure you have the correct pressure rated hose.

SERVICE - FLUIDS

Hydraulic Oil

NOTICE

Ensure area is clean before changing hydraulic oil and filters to avoid contamination, such as dirt and debris. Failure to comply may result in severe hydraulic system damage.

NOTICE

Ensure engine is off before filling hydraulic oil reservoir.

Check the Hydraulic Oil Reservoir Sight Gauge level daily. Add just enough fluid to maintain oil level at mid-sight gauge.

*NOTE: Hydraulic oil expands when heated.
Always check oil level when it is cool.*

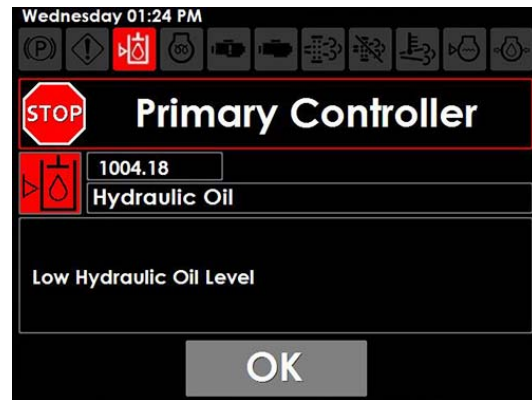
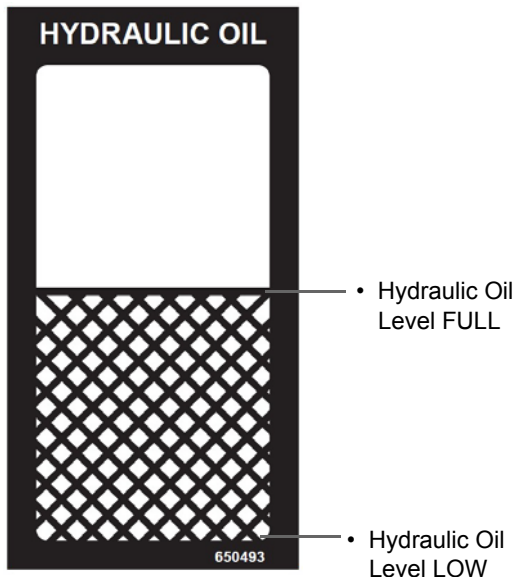

Low Hydraulic Oil Level Warning Message
(Located on the Machine Display)

NOTE: Replace hydraulic oil every 1,000 hours of operation.

Filling the Hydraulic Oil Reservoir

Capacity

- 34 gallons (128L)

Type

- John Deere Hy-Gard™ J20C Hydraulic Oil

Hydraulic oil can be added two different ways:

1. Through the hydraulic oil fill port (located on the side of the hydraulic return filter housing); or
2. Through the top of the hydraulic return filter housing. Remove bolts and cover to access.

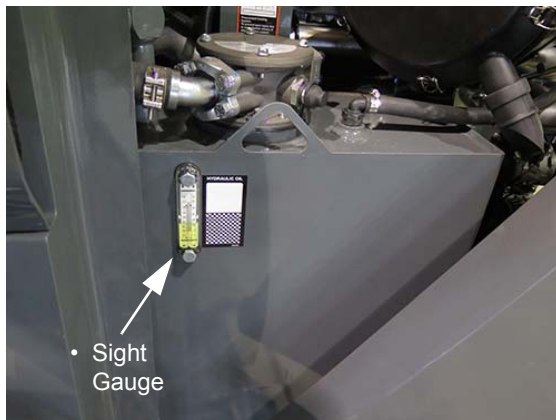

Hydraulic Oil Reservoir
(Located on left-hand side of machine - open hood to access)
-Typical View

If hydraulic oil level is too low for safe operation, a warning message will appear on the Machine Display to alert you of low hydraulic oil level. Press OK to acknowledge, shut down the engine immediately, and refill reservoir to proper level to avoid damage to the hydraulic systems.

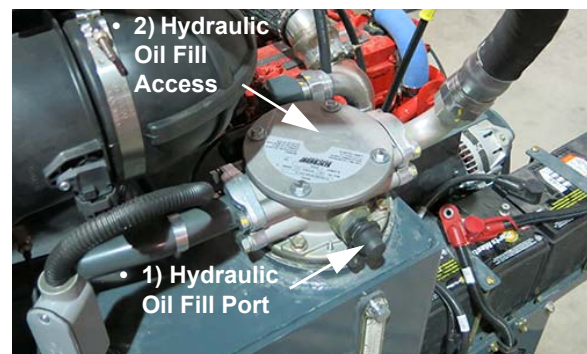

Hydraulic Oil Fill Options
-Typical View

Method 1 - Filling Through Hydraulic Oil Fill Port (Preferred Method)

NOTE: A hydraulic oil pump is required to fill through the hydraulic oil fill port, as gravity will not work and there is a small pressure to be overcome.

NOTE: Two (2) quick coupler fittings are provided in your tool kit to provide connection between the hydraulic oil fill port and the hydraulic oil pump that you are using.

- Remove the fill port rubber end cap.
- Attach hydraulic oil pump quick-connect fitting to the hydraulic oil fill port.
- Slowly squeeze pump handle and fill reservoir until oil level reaches mid-sight gauge.

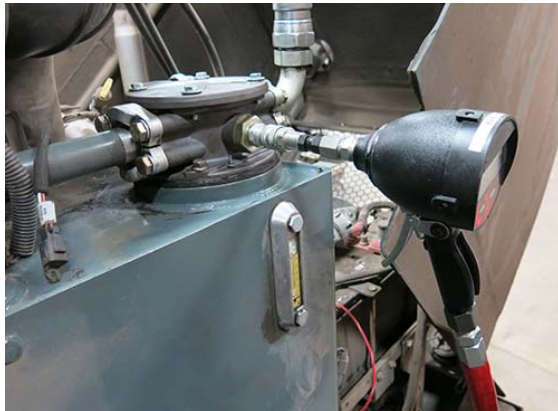

Filling Tank Through Hydraulic Oil Fill Port
-Typical View

- When finished filling, release pump handle and disconnect quick-connect fitting from fill port.
- Reinstall fill port rubber end cap.

Method 2 - Filling Through Hydraulic Return Filter Housing

NOTE: Clean dirt/debris from return filter housing cover before removing.

- Using a 1/2" wrench, remove the four (4) bolts (located on top of the hydraulic return filter housing) and set aside.
- Remove cover and fill reservoir until oil level reaches mid-sight gauge.



Filling Tank Through Hydraulic
Return Filter Housing
-Typical View

- When finished filling, reinstall hydraulic return filter housing cover and bolts.

Wheel Hub Oil

Fairfield Wheel Hubs

Each wheel hub should maintain a proper oil level at all times. Less than that would limit lubrication and overfilling would cause overheating and machine damage.

Capacity

- 56 oz./1.7L (w/o service brake)
- 50 oz./1.5L (w/ service brake)

NOTE: Fluid capacities apply when filling a wheel hub for the first time. Refilling after draining during an oil change would require fewer ounces.

Type

- Mobiltrans™ AST Gear Oil - All Season Transmission (CAT T0-4 rated)

To check the oil level:

NOTE: Check wheel hub oil level every 100 hours of operation.

1. Position wheel hub so the bottom (oil drain) face plug is positioned at 6 o'clock (A).

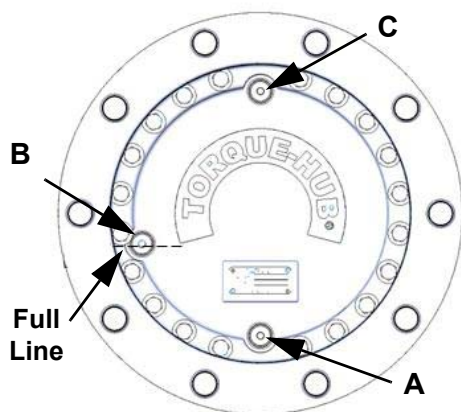

2. Remove 8 o'clock plug (B). If no oil comes out, proceed to Step 3.
3. If oil is needed, remove the top plug (C) and fill until oil begins to come out of the 8 o'clock plug (B).
4. Reinstall plugs.

To change the oil:

NOTE: Wheel hub oil should be changed after the first 50 hours of operation. After that, it should be changed every 250 hours of operation or yearly, whichever occurs first.

1. Position wheel hub so one of the face plugs is positioned at 6 o'clock and the other plug is positioned at either the 3 or 9 o'clock positions.
2. Remove plugs to drain oil.
3. Once all of the oil is drained, reinstall the bottom plug and remove the 3 or 9 o'clock plug.
4. Rotate wheel hub to the "fill" position so one of the plugs is positioned at 12 o'clock and the other plug is positioned at either the 3 or 6 o'clock positions.
5. Refill wheel hub with oil until satisfactory level is met.
6. Reinstall plugs.

General Maintenance

NOTICE

Failure to rotate the wheel hub and disperse oil may cause rusting and internal wheel hub damage.

If your machine is going to sit unused for an extended period of time, occasionally rotate the wheel hubs by driving the machine forward and backward - at least half of a tire rotation to adequately coat all internal wheel hub parts. This will prevent rusting if moisture inadvertently entered the wheel hub during an oil change.

Engine Oil

NOTICE

Never operate the engine with oil level below the "L" (low) mark or above the "H" (high) mark on the engine oil dipstick.

NOTICE

The engine must be level when checking oil level to ensure accuracy.

The Engine Oil Dipstick is located inside the oil fill on the left-hand side of engine (remove cap to access). Wait at least five (5) minutes after shutting the engine off to check the oil level.

NOTE: Check the engine oil level daily.

Capacity

- Engine Oil Dipstick (low to high mark capacity) = 2.3 quarts (2.2L)
- Engine Oil Pan Capacity (including filter, remote lines, and cooler) = 34.4 quarts (32.6L)

Type

- John Deere Plus-50™ II Premium Engine Oil

NOTE: John Deere Break-In™ Plus special-purpose engine oil is to be used during the initial break-in period (first 500 hours of operation). Thereafter, John Deere Plus-50 II premium engine oil is to be used.

NOTE: Use of any engine oil other than the recommended type (or less than API CJ-4 specification) will require the oil to be changed every 250 hours of operation.

NOTE: Change the engine oil every 500 hours of operation or yearly, whichever occurs first.

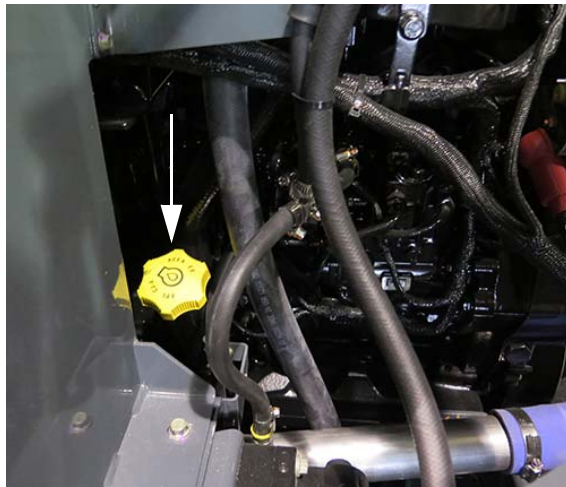

Engine Oil Fill
(Located on the left-hand side of engine - open hood to access)
-Typical View

**Diesel Exhaust Fluid (DEF)
(Final Tier 4 Engines)**

| |
|--|
| WARNING |
| <p>Read the DEF manufacturer's label and comply with safety precautions to avoid injury or damage.</p> |

| |
|---|
| <p>NOTICE</p> |
| <p>Never operate the engine with low DEF level. If DEF reaches a level that is too low for safe operation, the engine will begin to derate.</p> |

| |
|--|
| <p>NOTICE</p> |
| <p>Ensure engine is off before filling the DEF tank.</p> |

Check the DEF Gauge (located on the cab A-post) daily. Add just enough DEF to keep the DEF tank full.

| DEF Indicator Lamp Status |
|--|
| <ul style="list-style-type: none"> • When DEF level reaches 10% (indicated on the DEF Gauge), DEF Indicator Lamp will illuminate. |
| <ul style="list-style-type: none"> • When DEF level drops to 5%, DEF Indicator Lamp will flash. |
| <ul style="list-style-type: none"> • When DEF level drops to 2.5%, initial engine derate begins. |
| <ul style="list-style-type: none"> • When DEF level drops to 0%, secondary engine derate begins. |

NOTE: Depending on the selected final inducement option, 30 minutes after the DEF Gauge reads 0%, the engine will either be locked at idle or will shut down. Refer to the engine manufacturer's service manual for information on how to recover from a low DEF level condition.



DEF Gauge
(Located on cab A-post)
-Typical View

Capacity

- DEF Tank Capacity = 7.8 gallons (29.5L)

Type

- Use only DEF which meet ISO 2224101 standards.

NOTE: John Deere Diesel Exhaust Fluid recommended.

NOTE: Refill tank with DEF every other fuel fill to maintain adequate fluid level.

Filling the DEF Tank

Refer to “Engine Aftertreatment - Final Tier 4” provided in the *Engine and Drive Systems Section* elsewhere in this manual for further information.

DEF Storage

DEF has a limited shelf life, both in the machine’s DEF tank and in storage containers. The following conditions are ideal for maintaining DEF quality and shelf life during prolonged transportation and storage:

- Store DEF between 23° F (-5° C) and 77° F (25° C).
- Store DEF in sealed containers to avoid contamination.
- Avoid direct sunlight.

By following these conditions, DEF has a minimum expected shelf life of approximately 18 months.

NOTE: When storing DEF in higher temperatures for an extended period of time, the shelf life will be reduced by approximately 6 months for every 9° F (5° C) above the highest storage temperature as previously listed.

Long-term DEF storage in a machine (in excess of 6 months) is not recommended. If long-term storage is necessary, periodic testing of the DEF is recommended to ensure adequate concentration. Having the correct concentration of DEF is critical in engine and aftertreatment system performance.

NOTE: To help prevent DEF deterioration when stored in the DEF tank, locate and plug the tank venting to seal tank exposure against environmental elements.

Checking DEF Concentration

DEF concentration should be checked when the machine has been stored for an extended period of time or if it is suspected that water has been added to the DEF tank.

- Use a refractometer to check DEF concentration.

NOTE: Refer to the engine manufacturer’s operation manual for further information on checking DEF concentration.

- If the DEF concentration is found to be inadequate (outside of recommended specification):
 1. Drain the DEF tank.
 2. Flush tank with distilled water.
 3. Refill tank with new DEF.
 4. Recheck DEF concentration.

Freezing

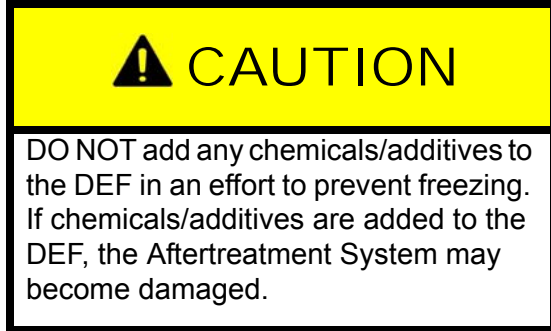

DEF will freeze around 12° F (-11° C). The DEF system on the machine is designed to accommodate this and does not require any operator intervention.

DEF Disposal

Check with local authority regulations on proper DEF disposal requirements.

Cooling System



The cooling system should be sufficiently charged with an adequate mixture of antifreeze and water, regardless of climate, to maintain broad operating temperature range. Follow the coolant manufacturer's recommendations for your climate.

NOTE: The cooling system has been factory-filled with an ethylene glycol-based antifreeze.

Capacity

- Cooling System Capacity = 11 gallons (41L)

Type

- John Deere Cool -Gard™ II Engine Coolant

Checking Coolant Level/ Concentration



Check coolant level daily. Ensure the Surge Tank has adequate fluid level before operating. The Surge Tank is transparent and fluid volume is determined by the molded markings on the outside of the tank.



Surge Tank
(Located near the rear of machine - open hood to access)
-Typical View

A 50/50 ethylene glycol and water mixture is a conservative mixture, which allows protection against both overheating and freezing.

NOTE: If a stronger antifreeze mixture is required, ensure not to exceed the engine manufacturer's guidelines for antifreeze-water mixing. Refer to "ASTM D 6210" or "ASTM D 7715" standards for further information.

The following Ethylene Glycol Table gives a few examples of ethylene glycol antifreeze/water mixture protection values.

| Ethylene Glycol | | |
|-----------------|--------|--------|
| 40% | -23° C | -10° F |
| 50% | -37° C | -34° F |
| 60% | -54° C | -65° F |

Coolant concentration should be checked every 500 hours of operation or at the beginning of each spray season, whichever occurs first. A refractometer should be used to check concentration.

NOTE: "Floating Ball" type density testers are not accurate for use with a heavy duty diesel cooling system.

Changing Coolant

CAUTION

COOLING SYSTEM REQUIRES SPECIAL FILL PROCEDURE

- Open cab heater water valve by turning the cab temperature knob to "Heat" with ignition on.
- Fill radiator to bottom of fill neck using 50/50 EG coolant mixture.
- If radiator is drained completely and refilled faster than 3 gpm (11.4 l/min), radiator may need to be topped off.
- Run engine at operating temperature for 5 minutes.
- Shut off engine.
- Wait until coolant is below 122° F before removing cap to check coolant level.
- Top off cooling system if required.
- See operator's manual for total cooling system volume.

Coolant should be changed periodically to eliminate the buildup of harmful chemicals. Drain and replace the coolant every other spray season or 1,000 hours of operation, whichever occurs first. Refill with soft water only, as hard water contains minerals, which break down the anti-corrosion properties of the antifreeze.

Further Information

Refer to the engine manufacturer's operation manual for further information.

Engine Fuel

CAUTION

DIESEL FUEL CAN BE DANGEROUS

- Turn off engine before refueling.
- Do not smoke while refueling.
- Clear off any spilled fuel after refueling.

**ULTRA LOW
SULFUR FUEL
ONLY**

650431

NOTE: Keep a fire extinguisher nearby when refueling.

DO NOT fill fuel tank completely. Fuel can expand and run over. Wipe up all spilled fuel and clean with detergent and water before starting the engine.

Capacity

- Fuel Tank Capacity = 150 gallons (567L)

Type

- Ultra-Low Sulfur Diesel (ULSD) fuel required.

Filling the Fuel Tank

NOTE: Your machine is featured with a fuel fill ladder (located beneath the fuel tank on the right-hand side of machine) for ease in accessing the

fuel and diesel exhaust fluid (DEF) tank fill ports. Refer to “Ladder - Fuel Fill” provided in the Miscellaneous Section elsewhere in this manual for further information.

1. Shut the engine off.
2. Remove Fuel Fill Cap and set aside.



Engine Fuel Fill
(Located on top of fuel tank
on right-hand side of machine)
-Typical View

3. Fill tank to desired level.
4. Reinstall the Fuel Fill Cap.

Air Conditioning

NOTICE

Charge with R-134A only. Charge to 4.00 lbs.



DO NOT MIX REFRIGERANTS

Recharging the AC System

The cab is equipped with an R-134A Air Conditioning System. **Recharge system with R-134A refrigerant only.**

NOTE: Confirm refrigerant before recharging the Air Conditioning System. If your system is mistakenly recharged with R-12 refrigerant, machine damage (such as compressor seizure) may result. If you do not have the proper equipment, it is recommended that you allow an authorized service technician service your Air Conditioning System.

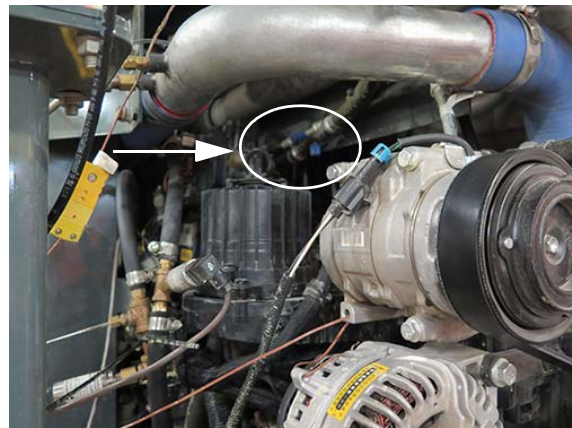

A/C Charge Ports
(Located inside engine compartment
- open hood to access)
-Typical View

Windshield Washer Fluid

The Windshield Washer Fluid Reservoir is located behind the left-hand side of cab. Check fluid level before each use and fill with non-freezing automotive windshield washer fluid, as required.



Windshield Washer Fluid Reservoir
(Located behind the left-hand side of cab)
-Typical View



Engine Air Intake Filter
(Located on rear left-hand side of
machine - open hood to access)
-Typical View

SERVICE - FILTERS

Engine Air Intake

The Engine Air Intake Filter is located on the rear left-hand side of machine (open hood to access). This premium filter removes contaminants from the intake air to optimize air quality and increase engine performance. The Engine Air Intake is featured with a dual-type air cleaner, ensuring air entering the engine is as clean as possible.

NOTICE

Do not tap filter to remove dust. A crushed filter caused by tapping may result in engine damage. Remove and replace filter as recommended.

Removal and Replacement

NOTE: The Engine Air Intake Filter should only be removed if replacement is required.

1. Release the six (6) Security Latches (located around the filter housing end cap). Remove end cap and set aside.

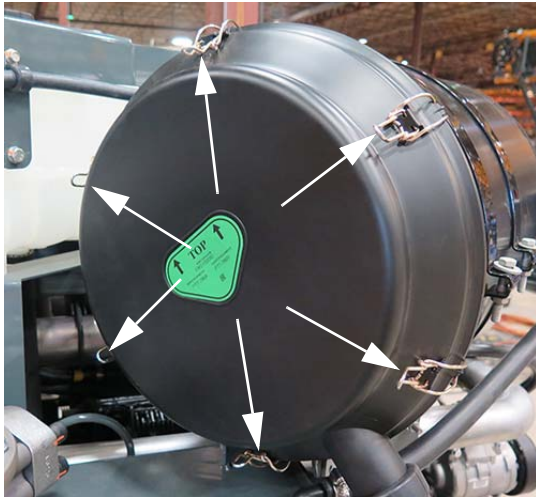

Security Latches
(Located around the filter housing end cap)
-Typical View

2. Remove and discard filter.

NOTE: Use care when removing the filter to ensure dust from the filter does not enter the air intake passage.

3. Install new Engine Air Intake Filter.



Engine Air Intake Filter
(Shown with end cap removed)
-Typical View

4. Reinstall the filter housing end cap and re-latch the Security Latches.

Replacement

An air filter service interval message will appear on the Machine Display notifying you that the engine air filter is restricted and that filter replacement is recommended.

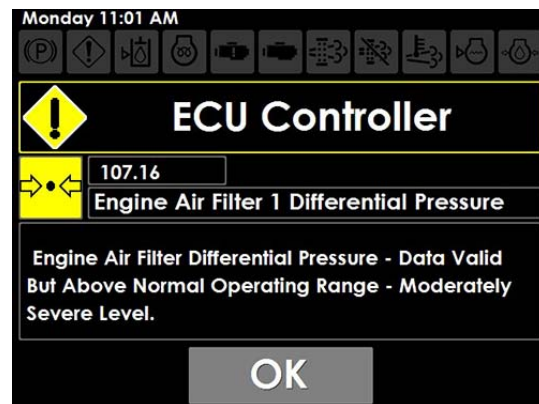
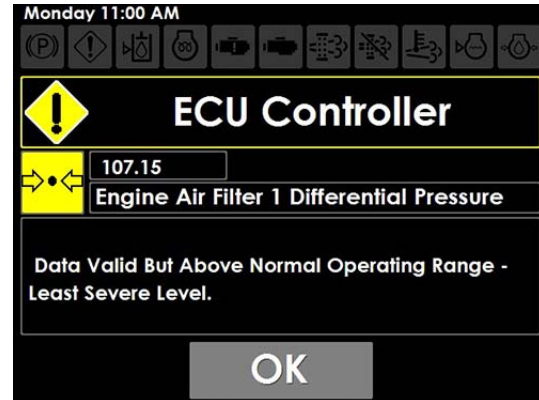

Cleaning

It is not recommended to clean the Engine Air Intake Filter element. However, a clean damp cloth should be used to wipe away dust and debris from the air cleaner housing.

Radiator Screen

NOTICE

Failure to keep cooling systems clean can cause overheating and damage to the engine and hydrostatic systems.

To maintain adequate airflow through the engine cooling system, the Radiator Screen (located ahead of rear hood) must be inspected daily and cleaned as necessary.

To Remove the Radiator Screen

- Remove the two (2) Engine Scoop Spring Clips (located on the top left and

right-hand side of inside scoop) and set aside.

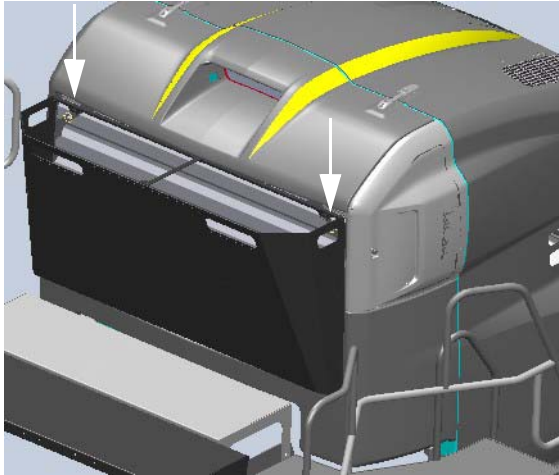

Engine Scoop Spring Clips
(Located on the top left and
right-hand side of inside scoop)
-Typical View

- Remove Engine Scoop from mounts and set aside.
- Remove the two (2) Radiator Screen Spring Clips (located on the top left and right-hand side of screen) and set aside.



Radiator Screen Spring Clips (2)
(Located on the top left and
right-hand side of screen)
-Typical View

- Extend the top of Radiator Screen outward and lift the bottom of screen out of lower pin cradles.

To Reinstall the Radiator Screen

- At a slight angle, install the lower screen pins into the pin cradles (located near the bottom of the cooling pack), as shown in the following illustration.

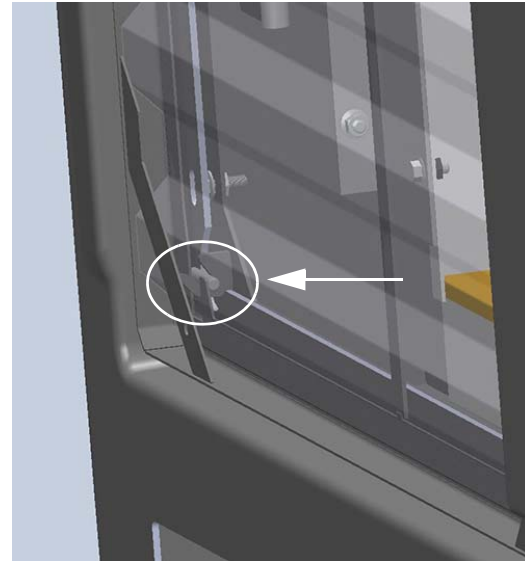

-Typical View

- Rotate screen inward until the mounting pins protrude through the screen.
- Reinstall the two (2) Radiator Screen Spring Clips.
- Reinstall Engine Scoop and Engine Scoop Spring Clips.

Cleaning the Radiator Screen

Use compressed air to dislodge large debris and dirt. Water from a pressurized hose may also be used or if necessary, the screen may be soaked with soapy water and scrubbed gently with a brush.

NOTE: When cleaning the cooling fins of the radiator, oil cleaner, or A/C condenser with compressed air or water, be careful not to damage the cooling fins, which may impair cooling capabilities.

Engine Oil Filter

The Engine Oil Filter (located on rear left-hand side of machine below hydraulic oil reservoir) should be replaced every 500 hours of operation or whenever the oil is changed, whichever occurs first.

Refer to the engine manufacturer's operation manual for further information and specifications.



Engine Oil Filter
(Located on rear left-hand side of machine below hydraulic oil reservoir)
-Typical View

Fuel Filters

Primary Fuel Filter (Water Separator)

The Primary Fuel Filter (located on rear left-hand side of machine behind hydraulic oil reservoir) should be drained of water and other deposits daily. Replace the filter every 500 hours of operation or yearly, whichever occurs first.

Secondary Fuel Filter

The Secondary Fuel Filter (located on rear left-hand side of machine behind hydraulic oil reservoir) should be replaced every 500 hours of operation or yearly, whichever occurs first.

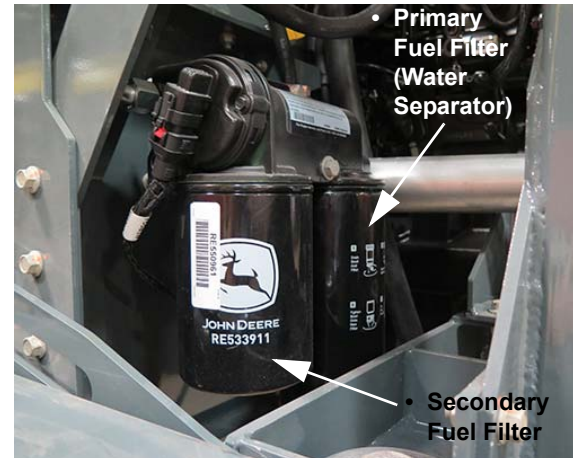

Primary and Secondary Fuel Filters
(Located on rear left-hand side of machine behind hydraulic oil reservoir)
-Typical View

NOTE: John Deere recommends specific high performance fuel filters, which will aid in achieving optimum engine performance and efficiency. Refer to the engine manufacturer's operation manual for further information and specifications.

Diesel Exhaust Fluid (DEF) Supply Module Filter

(Final Tier 4 Engines)

The DEF Supply Module Filter (located beneath the DEF Supply Module - access from underside of machine) should be replaced every 4,500 hours of operation or every three (3) years, whichever occurs first.

Refer to the engine manufacturer's operation manual for further information and specifications.

1. Rotate the DEF Supply Module Filter in the "counter-clockwise" position to loosen.
2. Remove and discard filter.
3. Install new DEF Supply Module Filter and rotate in the "clockwise" position to tighten.

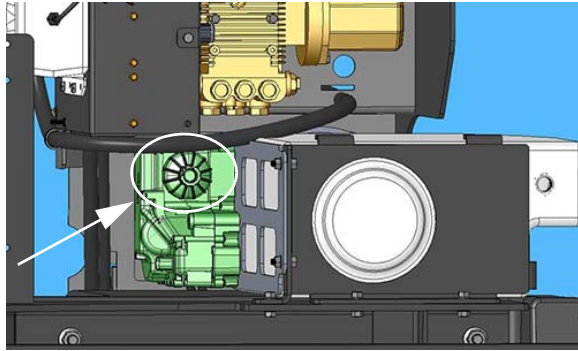

DEF Supply Module Filter
(Located beneath DEF Supply Module -
access from underside of machine)
-Typical View

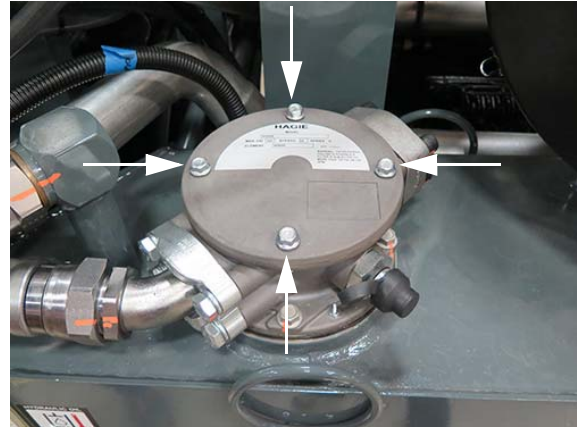

Return Filter Housing
(Located on top of hydraulic oil reservoir)
-Typical View

Hydraulic Filters

(Refer to your Parts Manual for specific location and replacement part numbers)

Remove and replace hydraulic filters every 500 hours of operation or yearly, whichever occurs first.

- Return Filter
- Pressure Filter
- Charge Pump Filter
- Case Drain Filters (2)
- Breather Cap

Replacing Hydraulic Filters

Return Filter

NOTE: Replace Return Filter when the filter indicator indicates that replacement is needed, becomes tripped, or after 500 hours of operation, whichever occurs first.

1. Remove the four (4) bolts on top of the Return Filter Housing (located on top of the hydraulic oil reservoir) and set aside.

2. Remove Return Filter Housing cover and set aside.
3. Remove and discard used Return Filter.



Return Filter
(Located inside filter housing
on top of hydraulic oil reservoir)
-Typical View

4. Install new Return Filter.
5. Reinstall filter housing cover and bolts.

Pressure Filter

1. Unlatch and lower metal shield (located beneath front end of machine).
2. Using a 15/16" wrench on the Pressure Filter Housing end bolt, turn "counter-clockwise" and remove filter housing.



Pressure Filter Housing
(Located beneath right-hand side of
machine - lower metal shield to access)
-Typical View

3. Remove and discard used Pressure Filter.
4. Install new Pressure Filter.
5. Reinstall Pressure Filter Housing and metal shield.

Charge Pump Filter

1. Ensure the engine is shut OFF.
2. Hold the Charge Pump Filter (located beneath the drive pump) in place and remove filter from housing using a 24mm wrench.

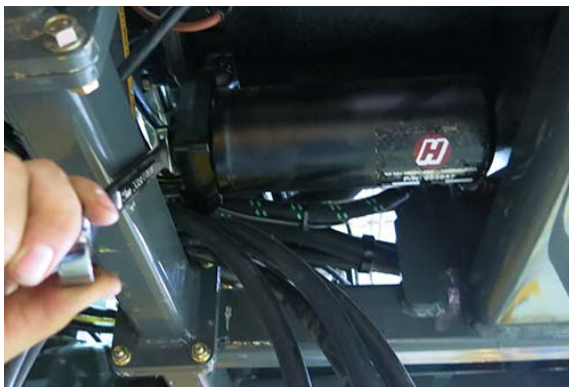

Charge Pump Filter
(Located beneath drive pump)
-Typical View

3. Remove and discard used Charge Pump Filter.

NOTE: Inspect the plug and seal surfaces in the filter bracket. Replace any damaged components.

4. Lubricate the seal and o-ring with hydraulic fluid.
5. Insert plug into filter bracket.
6. Using a 24mm wrench to hold the plug in place, install new Charge Pump Filter.

NOTE: Hand-tighten filter until it makes contact with the o-ring, then tighten half a turn further.

7. Turn the engine ON.
8. Cycle the pump through normal machine operation and check for leaks.

Case Drain Filters (2)

1. Using a 2 1/4" wrench, loosen Case Drain Hose (located near top of hydraulic oil reservoir) to prevent siphoning when changing the Case Drain Filters.

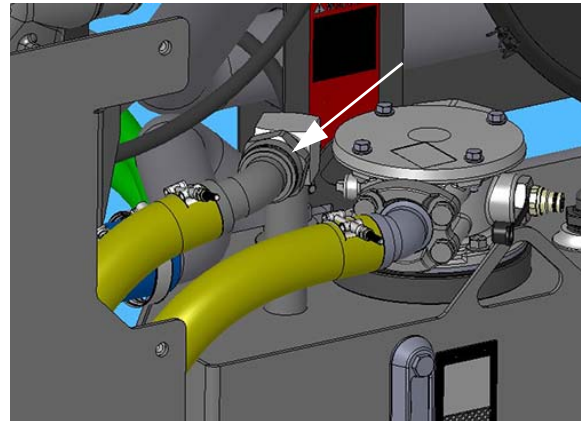

Case Drain Hose
(Located near top of hydraulic oil reservoir)
-Typical View

2. Turn desired Case Drain Filter (1 or 2) in the "counter-clockwise" position to loosen.



Case Drain Filter 1
(Located on right-hand side
of machine near batteries)
-Typical View

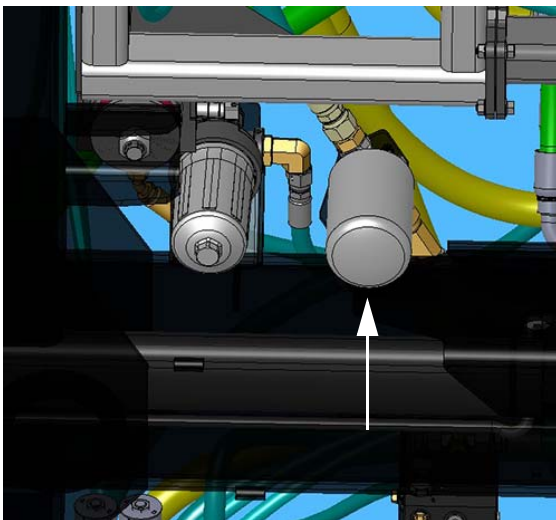

Case Drain Filter 2
(Located on left-hand side of
machine ahead of engine frame)
-Typical View

3. Remove and discard used Case Drain Filter.
4. Install new Case Drain Filter, turning in the “clockwise” position to tighten.
5. Repeat Steps 2 through 4 to change second Case Drain Filter.
6. Re-tighten Case Drain Hose.

Breather Cap

1. Loosen Breather Cap (located on rear left-hand side of machine behind air

intake filter) by turning “counter-clockwise”.



Breather Cap
(Located on rear left-hand side of
machine behind air intake filter)
-Typical View

2. Remove and discard used Breather Cap.
3. Install new Breather Cap and turn “clockwise” to tighten.

Strainers

(Refer to your Parts Manual for specific location and replacement part numbers)

Tank Rinse Strainer (Main Tank)

The stainless steel solution tank on your machine is equipped with a mesh Tank Rinse Strainer (located on top of solution tank). Inspect the strainer for blockage if you are unable to obtain adequate pressure through your rinse system.



Tank Rinse Strainer
(Located on top of solution tank)
-Typical View



Solution Line Strainer
(Located beneath the center
right-hand side of machine)
-Typical View

Solution Line Strainer

⚠ CAUTION

Ensure the Main Tank Valve and Agitation Valve are CLOSED before servicing the Solution Line Strainer. Failure to comply may result in chemical contact.

Maintain consistent application rates by inspecting the Solution Line Strainer (located beneath the center right-hand side of machine) daily for blockage. Clean the strainer screen as needed and ensure the gasket is in place before reinstalling the screen.

NOTE: Wear appropriate PPE while removing and cleaning the strainer screen.

Dual Product Solution Line Strainers (2) -If Equipped

⚠ CAUTION

Ensure both Solution Tank Valves and the Agitation Valve are CLOSED before servicing the Solution Line Strainers. Failure to comply may result in chemical contact.

Maintain consistent application rates by inspecting both Solution Line Strainers (Primary Solution Line Strainer located beneath the center right-hand side of machine, and the Secondary Solution Line Strainer located near the front right-hand side of machine) daily for blockage. Clean the strainer screen as needed and ensure the gasket is in place before reinstalling the screen.

NOTE: Wear appropriate PPE while removing and cleaning the strainer screen.

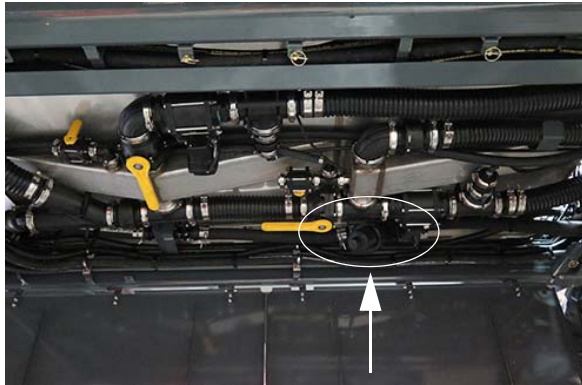

Solution Line Strainer - Primary
(Located beneath the center
right-hand side of machine)
-Typical View

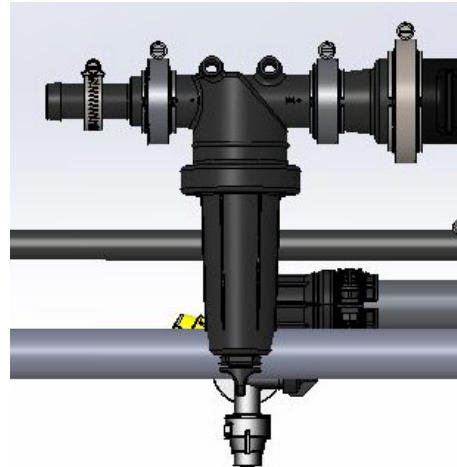

Section Strainer
(Located throughout each boom section)
-Typical View



Solution Line Strainer - Secondary
(Located near the front
right-hand side of machine)
-Typical View

Rinse Tank Strainer

- If Equipped

If your machine is equipped with a foam marker system, it will have a mesh Rinse Tank Strainer (located near the rinse tank outlet). Inspect the strainer for blockage if you are unable to obtain adequate pressure.

Hand Wash Strainer

A strainer is located near the bottom of the hand wash tank. Remove strainer and clean screen periodically to avoid dirt and debris from entering the system.

Section Strainers

- If Equipped

(80-Mesh Strainer Screens)

Section Strainers are located throughout each boom section and filter impurities to aid in the avoidance of spray nozzle buildup. Remove bottom section of each strainer and clean strainer screen as needed.

NOTE: Wear appropriate PPE while removing and cleaning the strainer screen.

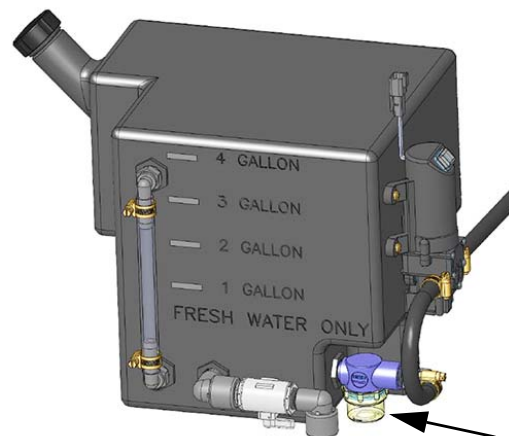

Hand Wash Strainer
(Located near bottom of hand wash tank)
-Typical View

Cab Filters

RESPA® Cab Filter

NOTE: Replace the RESPA Cab Filter every 1,000 of operation or when cab pressure drops below the minimum pressure threshold (when cab is sealed), whichever occurs first.

Replacing the RESPA Cab Filter

⚠ CAUTION

Do not clean or reuse filters. Failure to comply may create health hazards.

NOTICE

Replace filter in a clean and covered area to reduce operator and HVAC exposure to harmful particulates.

NOTICE

Ensure engine is turned OFF before servicing the RESPA Cab Filtration System.

NOTICE

When cleaning your machine, care should be taken to prevent high-pressure water or air from entering the RESPA Filtration System ejection slots. When replacing the slotted filter, do not point ejection slots at a solid surface in close proximity to the slots.

NOTE: Wear Personal Protective Equipment (PPE) when servicing the RESPA Cab Filtration System.

1. Turn the engine OFF.

2. Inspect RESPA Cab Filtration System for damage.
3. Release the four (4) Filter Latches (located on the exterior filter housing).

NOTE: Note orientation of the ejection ports.

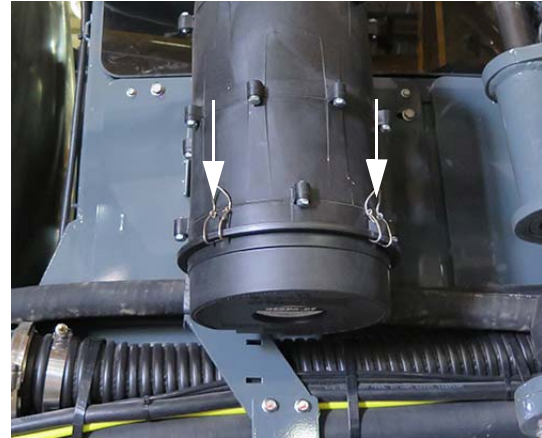

Filter Latches
-Typical View

4. Remove filter.

NOTE: When removing filter, place thumbs on exterior filter housing hardware for additional leverage.



Filter Removal
-Typical View

5. Place used filter in a sealed plastic bag and dispose.

NOTE: Dispose of filter according to local regulations.

6. Wipe off any loose debris around the filter housing using a clean cloth.

NOTE: DO NOT use compressed air to clean the filter housing.

7. Before installing the new filter, inspect the RESPA Cab Filtration System and replacement filter for proper operation.
8. Turn RESPA Filtration System ON, staying clear of the open end of the filter housing.
9. Ensure adequate airflow is blowing out of the empty filter housing.
10. Turn RESPA Filtration System OFF.
11. Install new filter.

NOTE: Ensure new filter ejection port orientation is correct and the filter end cap is properly seated on the filter housing (with the gills pointing downward to avoid water from entering in).

12. Re-latch the four (4) Filter Latches.
Refer to your Parts Manual for replacement part number.

Charcoal Filter

Remove and replace the Charcoal Filter at the first sign of chemical odor entering the cab area, or every 500 hours of operation at a minimum. Refer to your Parts Manual for replacement part number.

Accessing the Charcoal Filter

1. Loosen the top metal Flange Clamp (located near the top of the RESPA filtration unit).



Flange Clamp - Top
(Located near the top of the RESPA filtration unit)
-Typical View

2. Separate the RESPA filter housing from the vent tube.
3. Remove the four (4) Mounting Bolts (two located on each side of access panel on the right-hand side of cab) and set aside.



Mounting Bolts (4)
(Two located on each side of access panel on the right-hand side of cab)
-Typical View

4. Carefully lower access panel/filter assembly to the ground.

- With the access panel removed, loosen and remove the Security Screw (located along the inside of filter compartment) and set aside.



Security Screw
(Located along the inside
of filter compartment)
-Typical View

- Remove the Filter Bracket (located along the right-hand side of charcoal filter) and set aside.

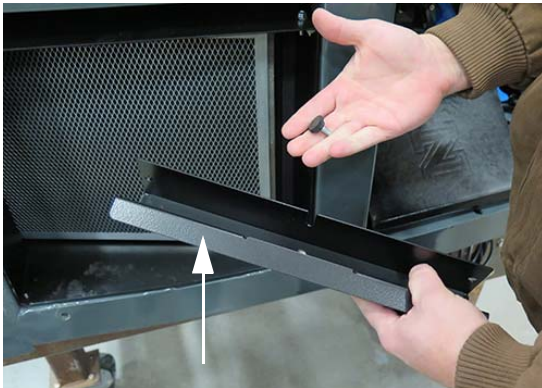

Filter Bracket
(Located along the right-hand
side of charcoal filter)
-Typical View

- Remove Charcoal Filter.



Charcoal Filter
-Typical View

- Replace Charcoal Filter and reverse steps to reinstall.

Recirculation Filter

A Recirculation Filter is located along the right-hand side of compartment (accessible after the Charcoal Filter has been removed). Remove the Recirculation Filter and clean with soap and warm water (wring out gently) anytime that the Charcoal Filter is replaced.

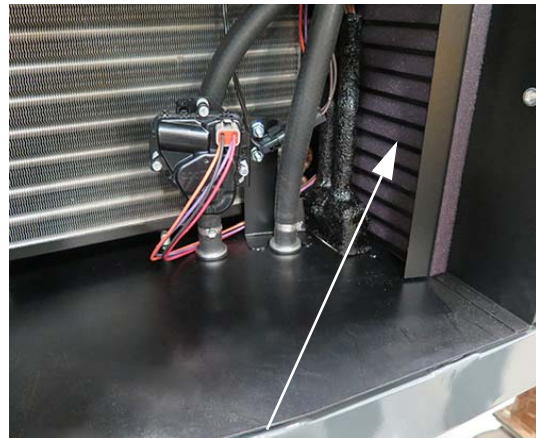

Recirculation Filter
(Located along the right-hand
side of compartment)
-Typical View

SERVICE - LUBRICATION

NOTICE

Failure to properly lubricate pivot and friction points may result in unnecessary wear and damage.

NOTICE

Mobilgrease XHP™ 222 (complying with NLGI 2, EP, ISO 220 specifications) recommended.

Legs and Steering

Grease Zerk Bank

-If Equipped

Your machine may be equipped with Grease Zerk Banks* (located on the front side of each leg) to lubricate the leg and steering grease zerks from one convenient location.

- Remove cap from the bottom of the corresponding grease zerk port and apply grease as required.



Grease Zerk Bank (4)
(Located on the front side of each leg)
-Typical View

Tie Rod Ball (front legs)

- Lubricate every 25 hours of operation, or as needed.

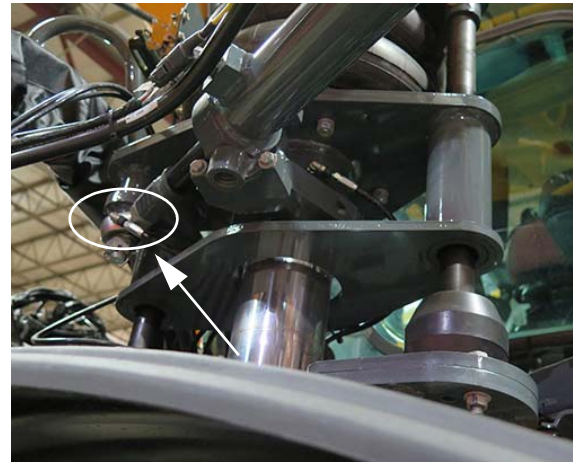

Tie Rod Ball Grease Zerk (2)
(Located on the front legs)
-Typical View

* Shown with grease bank hose connection

All-Wheel Steer (AWS) ^

- If Equipped

If your machine is equipped with AWS, the steering cylinders on the rear legs also have grease zerks in the tie rod ends that require lubrication.

Tower Bearing (front and rear legs)

- Lubricate daily, or as needed.



Tower Bearing Grease Zerks (8)
(Located on the front and rear legs)
-Typical View

* Shown with grease bank hose connections

Collar (air bag mounting plate)

- Lubricate every 50 hours of operation, or as needed.



Collar Grease Zerk (4)
(Located beneath each
air bag mounting plate)
-Typical View

** Shown with grease bank hose connection*

Leg Tubes (front and rear legs)

NOTE: Initial greasing should fill the grease space until grease escapes the pressure relief valve (between 40-80 psi/2.8-5.5 bar).

- Lubricate the legs weekly. When grease escapes the pressure relief valve, the proper grease level has been reached.

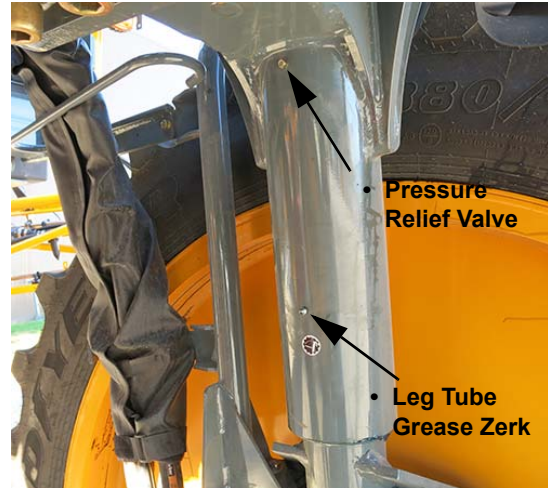

Leg Tube Grease Zerk and
Pressure Relief Valve
(Located on front and rear legs)
-Typical View

Ladder Pivot Tube

Lubricate the grease zerk (located on the back side of the Ladder Pivot Tube) every 50 hours of operation, or as required.

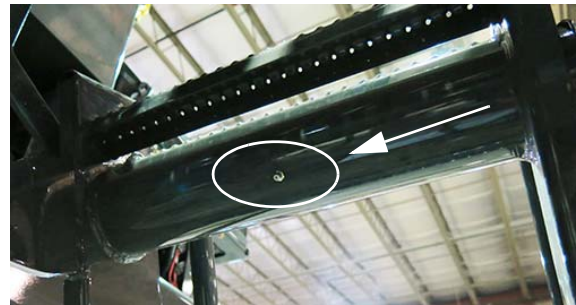

Ladder Pivot Tube
-Typical View

Fuel Fill Ladder

Gas Spring Axle

Lubricate the grease zerk on the Gas Spring Axle (located near the top left-hand side of ladder) weekly.

NOTE: Mobilgrease XHP™ 222 is recommended.



Gas Spring Axle Grease Zerk
(Located near the top
left-hand side of ladder)
-Typical View

Upper Ladder Pivot Points (4)

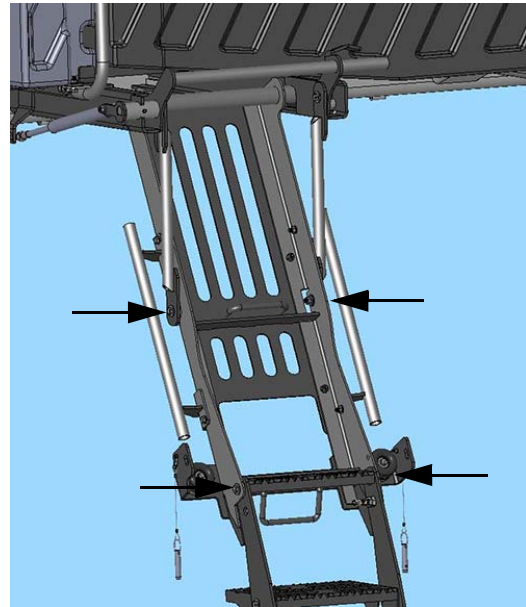

Upper Ladder Pivot Points (4)
-Typical View

Pivot Points (8)

Lubricate the Upper and Lower Ladder
Pivot Points weekly.

*NOTE: White lithium spray grease is
recommended.*

Lower Ladder Pivot Points - Platform (4)



Lower Ladder Pivot Points - Platform (4)
-Typical View

90/100' Booms

Transom Pivot Tubes

Lubricate the grease zerk on the Transom Pivot Tube - one on each side (that attaches the boom to the transom) every 50 hours of operation, or as needed.



Transom Pivot Tube
-Typical View

Boom Fold

Lubricate the Boom Fold (where the main boom section connects to the boom extension) daily, or as needed.



Boom Fold
-Typical View

Boom Breakaway

Lubricate the grease zerk on the Boom Breakaway daily, or as needed.

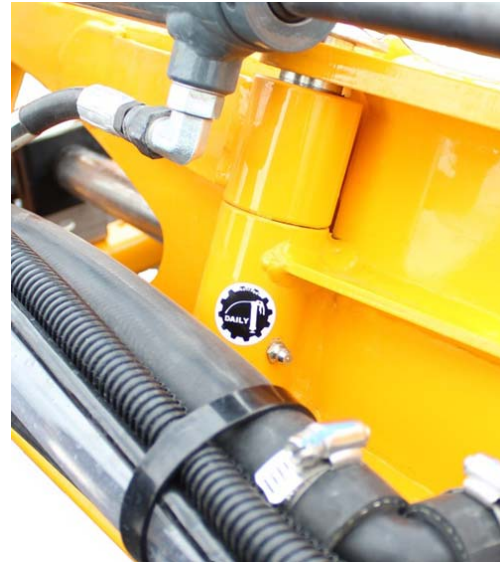

Boom Breakaway
-Typical View

Boom Breakaway Cylinder Rod End

NOTICE

Failure to lubricate the boom breakaway cylinder rod end grease zerks will result in damage to the breakaway cylinder and mounting if contact is made with an object.

Lubricate the grease zerk on the Boom Breakaway Cylinder Rod Ends daily, or as needed.



Boom Breakaway Cylinder Rod End
-Typical View



Roller Mount Assembly
-Typical View

120/132' Booms

Pendulum

Lubricate the grease zerk on each Pendulum weekly, or as needed.



Pendulum
-Typical View

Roller Mount Assembly

Lubricate the three (3) bearings on each Roller Mount Assembly daily, or as needed.

NOTE: Failure to keep the rollers properly lubricated may result in roller seizure.

Pivot Transom

Lubricate the four (4) Pivot Transom grease zerks (located at the top and bottom of each Pivot Transom) every 50 hours of operation, or as needed.

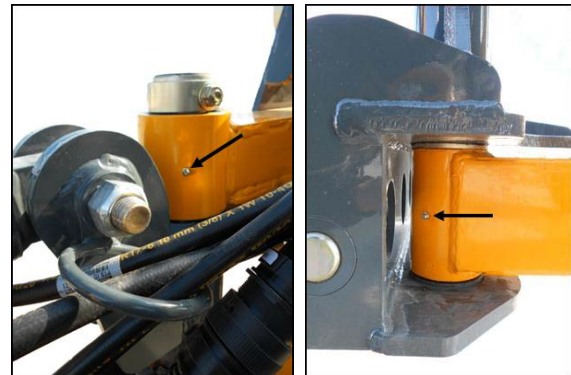

Pivot Transom
-Typical View

Pivot Transom Ball Joints

Lubricate the two (2) Pivot Transom Ball Joint grease zerks (located on the left and right-hand side of the Pivot Transom) every 25 hours of operation, or as needed.



Pivot Transom Ball Joints
-Typical View



Boom Adapter

Lubricate the two (2) grease zerks on each Boom Adapter every 25 hours of operation, or as needed.



Boom Adapter
-Typical View



Boom Fold Linkages
-Typical View

Boom Fold Linkages

Lubricate the grease zerks on the Boom Fold Linkages every 50 hours of operation, or as needed.

SERVICE - ENGINE DRIVE BELT

Removal

- Insert a 1/2" square ratchet drive into the belt tensioner. See following illustration.

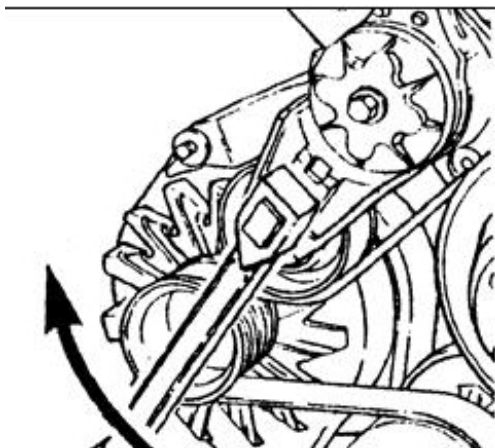

-Typical View

- Lift UP and remove Engine Drive Belt.

Inspection

- Visually inspect the Engine Drive Belt daily.
- Check the belt for intersecting cracks. See following illustration.

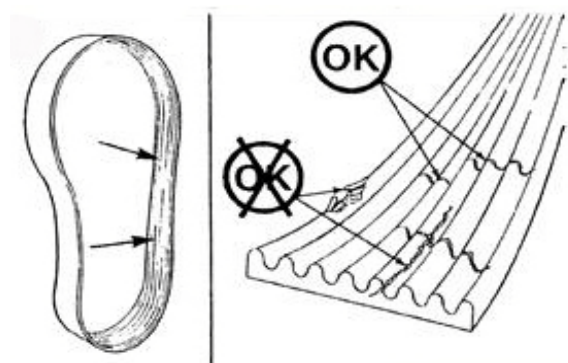

-Typical View

NOTE: Transverse cracks (across the belt width) are acceptable. Longitudinal cracks (direction of the belt length) that intersect with transverse cracks are not acceptable.

- Replace the Engine Drive Belt if it is frayed or has material missing.

SERVICE - BOLT TORQUE

NOTICE

Check lug nut torque immediately after receiving the machine and every 50 hours of operation thereafter.

Wheel Bolts

NOTE: If you do not have the proper equipment to mount a tire, contact a local qualified tire service center.

The tire should be mounted on the rim (as shown in the following illustration) for optimal traction and tread cleaning action.



To install wheel/tire assembly onto the wheel hub:

1. Ensure threads are thoroughly cleaned of rust and dirt.

NOTE: Threads should be dry (no lubricant).

2. Align the wheel bolt holes with the wheel hub studs.
3. Mount wheel on the hub.
4. Start all of the lug nuts and tighten until snug.
5. Following the torque sequence (as shown the following illustration), turn each lug nut to a torque value of 120 dry ft.-lbs.

NOTE: Use slow, even pressure on the torque wrench. Quick or jerky movements can cause inaccurate values.

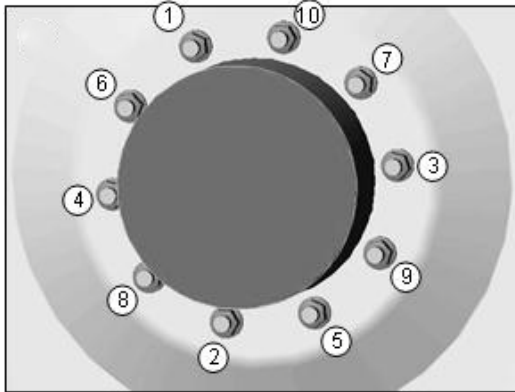

Torque Sequence

- Repeat the same sequence to 150 dry ft.-lbs. and again to 400-500 dry ft.-lbs.

NOTE: If the wheel turns during lug nut torquing, lower machine to the ground - just enough for the tire to touch and prevent rotation. Or, more preferably, place a suitable wedge between the tire and the ground. Lower the machine and resume operation. Recheck torque after 30 minutes of operation.

- When torquing is complete, lubricate exposed threads with anti-seize compound.

Hydraulic Tread Adjust Machines

With the engine turned OFF, visually inspect the tread bearing bolts on both the bottom and side tread adjust bearing plates daily. Inspect the torque every 100 hours of operation.

To check torque of the tread adjust bearing bolts:

- Loosen the jam nut on each tread adjust bearing bolt.



Jam Nut

(Located on each tread adjust bearing bolt)
-Typical View

- Using an “X” pattern (as shown in the following photo), verify that the current torque on each tread adjust bearing bolt is equivalent to the last inspection from 100 hours of previous operation.

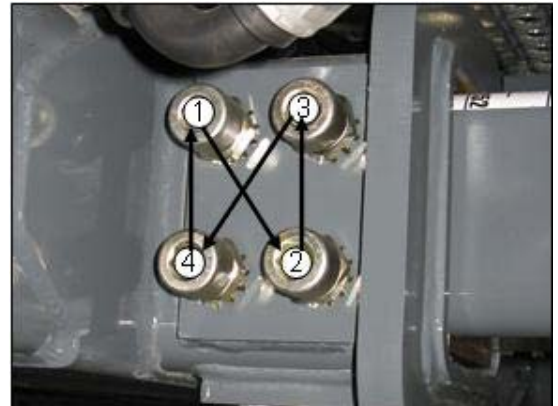

“X” Pattern

-Typical View

- Repeat pattern 3 to 4 times until the last sequence shows no movement of the bolts to achieve desired torque.
- Tighten jam nut.

Typically, a torque value of 20 to 25 ft.-lbs. is required to stabilize the axle and still allow tread width adjustment.

NOTE: Never operate machine with loose or missing tread plates. To visually inspect for loose tread plates, slowly rock the machine forward and backwards while observing the legs

for movement. If plates become loose, the leg will rock as the machine starts to move.

NOTICE

If hydraulic tread adjust will never be used, set all bolt torque settings to 50 ft.-lbs. using the following procedure.

EVEN PRESSURE OF THE TREAD ADJUST BEARING PLATES IS REQUIRED FOR PROPER OPERATION.

- **Figure A** - shows correct position of the tread adjust bearing plates and bolts, as well as the outer leg.
- **Figure B** - shows the plates when there is not even torque on each of the tread adjust bearing bolts.
- **Figure C** - shows a situation in which there is not enough torque on the tread adjust bearing bolts.

NOTE: Both Figures B and C will cause the tread adjust to operate incorrectly, or not at all.

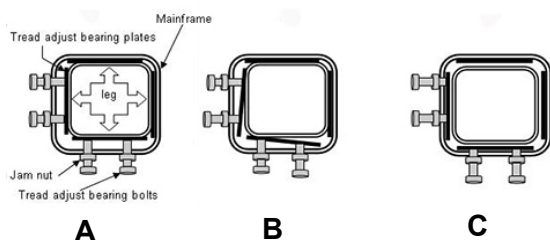

SERVICE - TOE-IN

Step 1 - Phase Steering Cylinders

The steering cylinders must be phased before any mechanical adjustments can be made (cylinder stroke = 8.8"/22.4 cm). When the cylinders are re-phased, each cylinder should reach mid-stroke (4.4"/11.2 cm). Once both cylinders are at 4.4"/11.2 cm, Toe-In can be set.

To Phase the Steering Cylinders

1. Start the machine.
2. Turn steering wheel to the right or left.
3. When the wheels stop turning, continue to turn the steering wheel 3 to 4 full revolutions (this will put the cylinders back in phase with each other).

Step 2 - Set Toe-In

Front Wheels

- .25" (.6 cm) Toe-In per side/0.5" (1.3 cm) total Toe-In

Rear Wheels

- 0" (0 cm) Toe-In/Out

To Set Toe-In

1. Deflate the air bags.

NOTE: Refer to "Air Suspension Exhaust" provided in the Miscellaneous Section elsewhere in this manual for further information.

2. Measure the distance from the ground to center of wheel hub.

NOTE: All four wheel hubs should measure the same distance.

3. Mark this distance on the inner edge of the wheel rim (front and back of each rim - 8 marks total).

NOTE: All measurements will be taken from these markings.

4. Visually align the tires from front to rear.

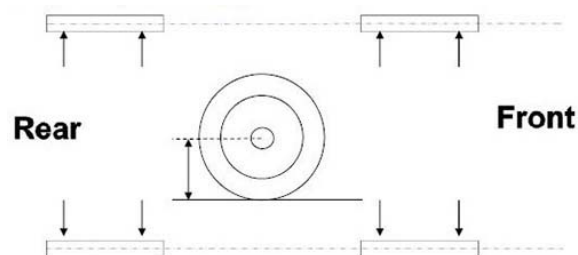

Front Wheels

5. Measure the width between the front wheels (front W1, rear W2) at the wheel hub center line and record measurements.
6. Adjust the wheels until the front and rear measurements are equal (W1=W2).

7. Measure diagonally (D1 and D2) and record the measurements.
8. Adjust the wheels until the measurements are equal.

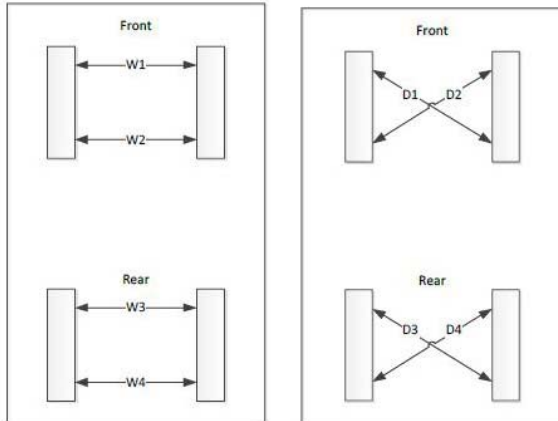

9. Continue to cycle between Steps 5-6 and 7-8 until the width measurements match and the diagonal measurements match. Then and only then are the wheels parallel to each other and the frame.

NOTE: To achieve this, both conditions must be met.

NOTE: The front steering cylinders must both be centered before proceeding!

10. Set both cylinders to center by measuring 7.64" (19.4 cm) (as shown in the following photo).

The position sensors should both read 4.4" (11.2 cm) when the cylinders are centered and in phase.

This is not required for All-Wheel Steer (AWS) machines, as the cylinder position sensors can be used to center the cylinders.

- *The cylinder sensors must be calibrated for this position to be accurate.*
- *If the cylinders do not center at this measurement, they are not in phase. To re-phase the cylinders, turn the steering wheel so that one cylinder is fully retracted and the other is fully extended. Turn the steering wheel at least one full turn past this point. Re-center the cylinders. If the measurements still do not match, repeat the cylinder air bleed procedure.*

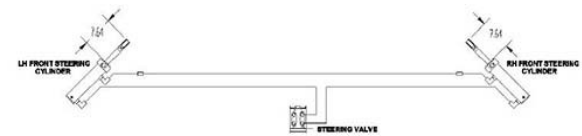

11. With the cylinders centered, adjust the tie-rods (located on the cylinder rods) until they line up with the bolt-down hole (located on the lower air bag plate).
12. Turn the tie-rod one more full turn to achieve desired amount of toe-in.
 - *When the rod ends are turned the final turn (to establish the desired amount of toe-in), the rod ends turn in opposite directions to get each wheel in toe.*
 - *If the amount of threads showing on the left and right rod ends differ by more than four (4) threads, repeat previous Steps 1-12. If the difference remains, there may be a tolerance issue in the leg assembly.*
13. Pry wheel in to allow rod end securing bolt to be inserted.
14. Insert the bolt and secure main bolt and cylinder jam nut to the proper torque specification.

Rear Wheels

NOTE: Rear wheels should be set to 0.0" (0.0 cm) toe in/out.

15. Repeat previous Steps 1-9.
16. **(Non-AWS Machines)** - Set tie rod assembly to match up with the bolt-down hole (located on the lower air bag plate). Insert bolt and secure to the proper torque specification.
17. **(AWS Machines)** - Repeat Step 10, centering the rear cylinders at 4.4" (11.2 cm). Insert bolt and secure main bolt and cylinder jam nut to the proper torque specification.

NOTE: The cylinder sensors must be calibrated for this position to be accurate.

- *The machine should be driven and toe (front and rear) rechecked.*
- *Front steering cylinders must be in phase when toe setting is checked.*
- *Failure to hold toe setting could indicate the presence of air in the cylinders.*
- *Repeat the cylinder bleeding procedure, if necessary.*

Further Information

Contact your local John Deere dealer if additional assistance is needed.

SERVICE - MISCELLANEOUS

Air Bags

The Air Bags (one located on each leg) provide a smooth, consistent ride quality. A ride control valve increases/decreases compressed air into the air bags to maintain ride height position as load or wheel position changes with ground level for each leg independently.

*NOTE: The front air bags are larger capacity to accommodate heavier loads for various front end attachments, yet maintain a smooth ride.**



Air Bag
(Located on each leg)
-Typical View
* Front Air Bag Shown

The system includes an Air Dryer (located beneath the service platform on left-hand side of machine) that dries air coming from the air compressor before sending it to a collection tank.

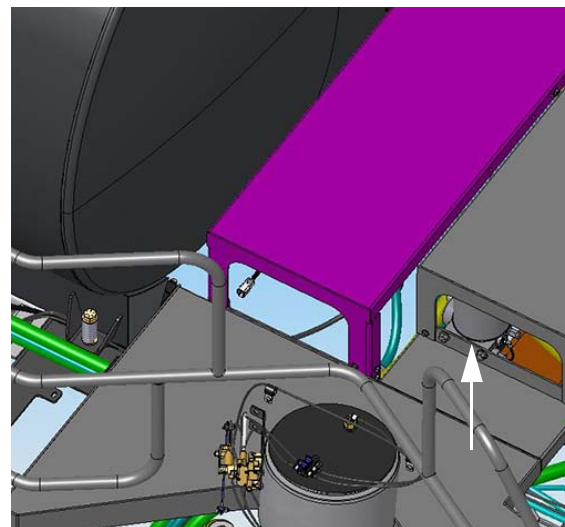

Air Dryer
(Located beneath service platform
on left-hand side of machine)
-Typical View

From the collection tank, air is sent to the Air Bags as needed to maintain a level pressure. Control valves open and close to allow air in.

- Inspect the Air Dryer cartridge every 50 hours of operation to ensure that it is purging with compressor load. Change the cartridge every 1,000 hours of operation, or as needed.
- Inspect Air Bags daily for leaks and/or cracking. If an Air Bag is low, check the bag for any punctures or leaks.

Contact your local John Deere dealer if assistance is needed.

Air Tanks



Your machine may be equipped with two Air Tanks. The **Main Air Tank - standard** (located beneath platform on the left-hand side of machine) provides a volume of compressed air to give faster response for changes in air volume to the air bags.

The **Air Purge Tank - if equipped** (located beneath platform near center of machine) is used to push solution out of the boom line, reducing the amount of rinse water needed to clean the solution system of chemical.

- Drain each Air Tank daily by slowly releasing the Tank Drain Valve.



Tank Drain Valve (Main)
(Located beneath platform
on left-hand side of machine)
** Pull DOWN to open*
-Typical View

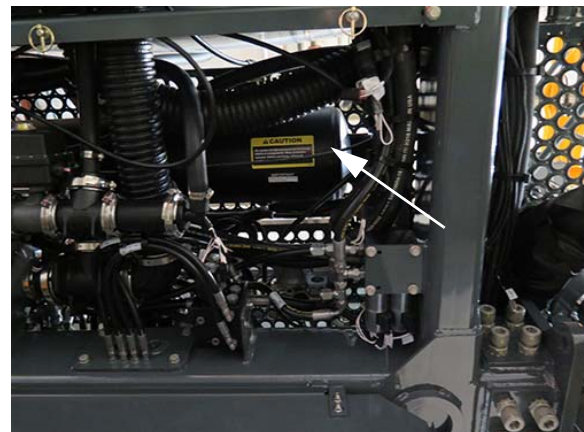

Tank Drain Valve (Air Purge) - *if equipped*
(Located beneath platform
near center of machine)
** Pull DOWN to open*
-Typical View

NOTE: Check for moisture. If excessive moisture is in the tank(s), there may be a system malfunction. Contact your local John Deere dealer if assistance is needed.

Tire Pressure

⚠ CAUTION

When inflating a tire, use an extension with an in-line air gauge and attach air chuck. This will allow the operator to stand clear of tire sidewall explosion trajectory.

- Check tire pressure weekly.
- Never inflate a tire more than the maximum air pressure (as stated on the tire sidewall or in the tire specifications table provided in the *Introduction Section* of this manual).
- Use an airline with a locking air chuck and stand behind tire tread while filling.

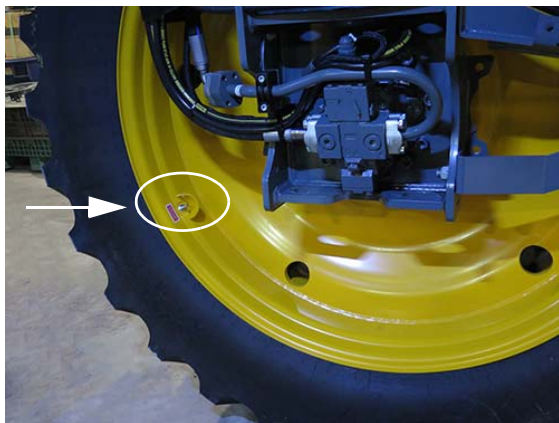

Valve Stem (4)
(Located on the inside of each wheel)
-Typical View

NOTE: Tire pressure will depend on type of tire used and amount of load.

Spray Booms

Nozzle Diaphragms

At the beginning of each season, remove each nozzle body cap (A) and inspect the diaphragm (B) for wear or fit. Replace diaphragms every 1,000 hours of operation, or as necessary.

Spray Tips

⚠ CAUTION

Never place a spray tip/nozzle to your mouth in an attempt to unplug it.

At the beginning of each season (or as required), remove a random sample of spray tip caps (C) and inspect the nozzle tips. If the tips are plugged or worn, clean or replace them. Replace spray tips every 1,000 hours of operation, or as necessary.

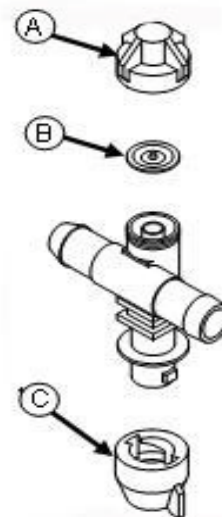

Nozzle Diaphragms and Spray Tips
-Typical View

NORAC® Sensor Foam Pads

Inspect the NORAC Sensor Foam Pads daily. Remove the foam pad from each sensor, blow out with compressed air, and reinstall.

NOTE: Ensure foam pads are clean and dry to ensure optimal performance.

NOTE: DO NOT blow the foam pad out while still installed on the sensor. Always remove foam pad before cleaning to avoid sensor damage.



NORAC Sensor Foam Pad
(Located on the bottom of each sensor)
-Typical View

Replace foam pads as necessary.
Contact your local John Deere dealer for replacement.

Wiper Blade

NOTICE

Use a sturdy stationary ladder to safely access the wiper blade.

Do not allow the Wiper Blade to run on a dry windshield, as this will shorten the life of the blade and/or cause scratching on the windshield.

NOTE: Replace the windshield wiper blade (39"/99 cm) as necessary.

The Windshield Washer Fluid Spray Nozzle is adjustable. The fluid spray pattern should be inspected at the beginning of each season, and adjusted as necessary.



Windshield Washer Fluid Spray Nozzle
(Located near top of exterior cab)
-Typical View

Washing the Machine

Wash the machine daily to remove any harmful chemical residue, which can be corrosive to paint and steel.

NOTE: Always wash machine thoroughly after applying liquid nitrogen.

As often as possible, thoroughly wash the machine and apply paint to any place where the paint is light or missing.

For replacement decals or touch-up paint recommendations, contact your local John Deere dealer.



SERVICE INTERVALS

| Service Point | Initial | Daily/ Before Each Use | As Required | 50 Hrs. | 100 Hrs. | 250 Hrs. ** | 500 Hrs. ** | 1000 Hrs. |
|--|---------|---------------------------------|----------------|------------|-------------|----------------|----------------|--------------|
| Check Lug Nut Torque (Break-in) | X | | | | | | | |
| Check Engine Oil Level | | X | | | | | | |
| Check Radiator Coolant Level | | X | | | | | | |
| Check Radiator Grille Screen | | X | | | | | | |
| Check Engine Drive Belt | | X | | | | | | |
| Check A/C Compressor Belt | | X | | | | | | |
| Check Hydraulic Oil Reservoir Level | | X | | | | | | |
| Check Solution Line Strainer(s) <i>NOTE: Two (2) Solution Line Strainers (Primary/ Secondary) are provided with the Dual Product System - if equipped</i> | | X | | | | | | |
| Check Batteries | | X | | | | | | |
| Check for Leaks Around the Machine | | X | | | | | | |
| Drain Air Tanks (Main Tank and Air Purge Tank) | | X | | | | | | |
| Check Windshield Washer Fluid Level | | X | | | | | | |
| Wash Machine Clean of Chemical Residue | | X | | | | | | |
| Check and Drain Primary Fuel Filter (Water Separator) | | X | | | | | | |
| Check Air Bags | | X | | | | | | |
| Check Tread Adjust Bearing Bolts (Visually) | | X | | | | | | |
| Check Engine Air Intake Piping | | X | | | | | | |
| Lubricate Boom Fold Grease Zerks (90/100') | | X | | | | | | |



SECTION 9 –
MAINTENANCE AND STORAGE

| Service Point | Initial | Daily/ Before Each Use | As Required | 50 Hrs. | 100 Hrs. | 250 Hrs. ** | 500 Hrs. ** | 1000 Hrs. |
|--|---------|---------------------------------|----------------|------------|-------------|----------------|----------------|--------------|
| Lubricate Boom Breakaway Grease Zerks (90/100') | | X | | | | | | |
| Lubricate Boom Breakaway Cylinder Rod End Grease Zerks (90/100') | | X | | | | | | |
| Lubricate Leg Grease Zerks | | | X | | | | | |
| Lubricate Fuel Fill Ladder Gas Spring Axle Grease Zerk | | | X | | | | | |
| Lubricate Fuel Fill Ladder Pivot Points | | | X | | | | | |
| Replace Windshield Wiper Blade | | | X | | | | | |
| Fill Windshield Washer Fluid Reservoir | | | X | | | | | |
| Clean Radiator Grille Screen | | | X | | | | | |
| Change Engine Drive Belt | | | X | | | | | |
| Change A/C Compressor Belt | | | X | | | | | |
| Charge A/C Compressor * | | | X | | | | | |
| Change Air Intake Filter | | | X | | | | | |
| Clean/Replace Solution Line Strainer(s) <i>NOTE: Two (2) Solution Line Strainers (Primary/ Secondary) are provided with the Dual Product System - if equipped</i> | | | X | | | | | |
| Clean Hand Wash Strainer | | | X | | | | | |
| Check Spray Nozzle Diaphragms and Tips | | | X | | | | | |
| Change Tread Adjustment Bearing Torque | | | X | | | | | |
| Change Batteries | | | X | | | | | |
| Change or Replace Fuses and Breakers | | | X | | | | | |
| Replace Charcoal Cab Filter | | | X | | | | | |
| Clean Cab Recirculation Filter | | | X | | | | | |
| Check Tire Pressure | | | X | | | | | |

SECTION 9 –
MAINTENANCE AND STORAGE



| Service Point | Initial | Daily/ Before Each Use | As Required | 50 Hrs. | 100 Hrs. | 250 Hrs. ** | 500 Hrs. ** | 1000 Hrs. |
|--|---------|---------------------------------|----------------|------------|-------------|----------------|----------------|--------------|
| Clean/Replace Rinse Tank Strainer (if equipped) | | | X | | | | | |
| Inspect/Replace Tank Rinse Strainer (Main Tank) | | | X | | | | | |
| Lubricate Air Bag Collar Grease Zerk | | | | X | | | | |
| Check Lug Nut Torque | | | | X | | | | |
| Lubricate Ladder Pivot Tube Grease Zerk | | | | X | | | | |
| Lubricate Boom Transom Pivot Tube Grease Zerks (90/100') | | | | X | | | | |
| Change Wheel Hub Oil (Break-in) | | | | X | | | | |
| Check Air Dryer Cartridge | | | | X | | | | |
| Check Wheel Hub Oil Level | | | | | X | | | |
| Clean Batteries | | | | | X | | | |
| Check Tread Adjust Bearing Bolt Torque | | | | | X | | | |
| Change Wheel Hub Oil | | | | | | X | | |
| Change Engine Oil | | | | | | | X | |
| Change Engine Oil Filter | | | | | | | X | |
| Change Primary Fuel Filter (Water Separator) | | | | | | | X | |
| Change Secondary Fuel Filter | | | | | | | X | |
| Change Hydraulic Return Filter | | | | | | | X | |
| Change Hydraulic Pressure Filter | | | | | | | X | |
| Change Hydraulic Charge Pump Filter | | | | | | | X | |
| Change Hydraulic Case Drain Filters (2) | | | | | | | X | |



SECTION 9 –
MAINTENANCE AND STORAGE

| Service Point | Initial | Daily/ Before Each Use | As Required | 50 Hrs. | 100 Hrs. | 250 Hrs. ** | 500 Hrs. ** | 1000 Hrs. |
|---|---------|---------------------------------|----------------|------------|-------------|----------------|----------------|--------------|
| Change Hydraulic Breather Cap | | | | | | | X | |
| Check Radiator Coolant Concentration | | | | | | | X | |
| Change Hydraulic Reservoir Oil | | | | | | | | X |
| Replace RESPA® Cab Filter | | | | | | | | X |
| Change Radiator Coolant | | | | | | | | X |
| Change Air Dryer Cartridge | | | | | | | | X |
| Change Spray Nozzle Diaphragms and Tips | | | | | | | | X |

* Use proper equipment.

** 250-500 hours or yearly, whichever occurs first.

| 120/132' Spray Boom Service Intervals | | | |
|--|--------------------------|--------|----------------|
| Service Point | Daily/Before Each Use | Weekly | As Required |
| Lubricate Roller Mount Assembly Grease Zerks | X | | |
| Inspect/Clean NORAC® Sensor Foam Pads | X | | |
| Lubricate Pendulum Grease Zerks | X | | |
| Lubricate Level Pin Adapter Plate Grease Zerks | | X | |
| Replace NORAC Sensor Foam Pads | | | X |
| Lubricate Pivot Transom Grease Zerks | | | X |
| Lubricate Pivot Transom Ball Joints | | | X |
| Lubricate Boom Adapter Grease Zerks | | | X |
| Lubricate Boom Fold Linkage Grease Zerks | | | X |
| Check Spray Nozzle Diaphragms and Tips | | | X |



STORAGE

Preparing For Storage

1. Perform daily level checks, lubrication, and bolt/linkage inspections, as required in this manual.
2. Every other season, drain the coolant from the engine and radiator. Probe the drain holes during drainage to ensure they are not clogged by sludge, scale, or other deposits.
Fill the cooling system to the top with a 50/50 water/antifreeze mixture. Run the engine to operating temperature and recheck level.
3. Add a fuel stabilizer to the fuel and fill the tank.
4. Run the engine until it reaches operating temperature, then drain the engine oil. Refill with fresh oil of recommended weight and install a new lubricating oil filter element.
5. With the engine at normal operating temperature, cycle all hydraulic functions, including the steering.
6. Release tension on all belts.
7. Use plastic bags and water-resistant adhesive tape to seal the air intake opening, all exhaust manifold openings, engine oil fill cap, hydraulic oil tank breather cap, and fuel tank cap.

NOTE: If the spray boom will be stored separately from the machine, ensure all boom hole openings are capped or covered with a suitable covering.

8. Turn the Battery Disconnect Switch OFF.
9. Disconnect and remove batteries. Completely clean and charge the batteries. Coat the terminals with dielectric grease and store the batteries in a cool place (above freezing).
10. Thoroughly wash the machine and its attachments. Touch up any painted surfaces that are scratched or chipped.

NOTE: For paint touch-up recommendations, contact your local John Deere dealer.

11. Replace worn or missing decals. Refer to “Safety Decals” in the *Safety and Pre-*

cautions Section for proper location of warning decals and corresponding part number.

NOTE: For decal replacement, contact your local John Deere dealer.

12. Apply multi-purpose grease to coat exposed hydraulic cylinder rods.
13. Refer to the Spray System Console manufacturer’s operation manual for detailed information on storage procedures for the console and flow meters.
14. If the machine must be stored outside, cover with a waterproof cover.

Dual Product System

-If Equipped

When storing your machine for the season, ensure both the Single and Dual Product Solution Systems are properly drained and cleaned.

Winterization

To winterize the spray system, it is recommended that you use an environmentally safe RV-type antifreeze and water mixture that will give you adequate protection to -30° F.

- Drain any remaining solution in the spray system.
- Thoroughly rinse the spray system.
- Run antifreeze/water mixture through the spray system until it comes out all of the boom openings.

NOTE: Ensure the Agitation Valve Switch (located on the side console) is in the OPEN position before running antifreeze/water mixture through the system.

Repeat process for both the Foam Marker and Rinse Systems.

Winterizing the Hand Wash System

1. Remove Drain Plug (located beneath the hand wash reservoir) and allow fresh water to drain from tank.

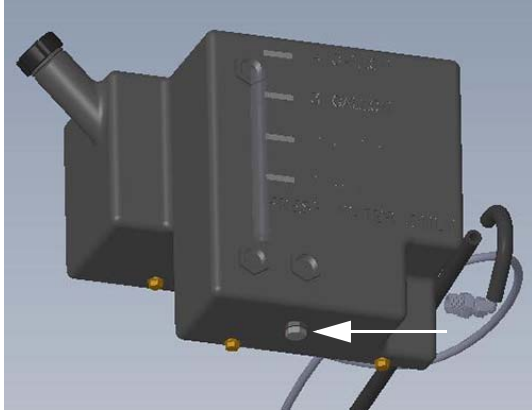

Drain Plug
(Located beneath the hand wash reservoir)
-Typical View

2. Reinstall drain plug.
3. Pour approximately 1 gallon (3.8 L) of RV-type antifreeze into the Hand Wash Fill Port (located beneath platform near ladder).

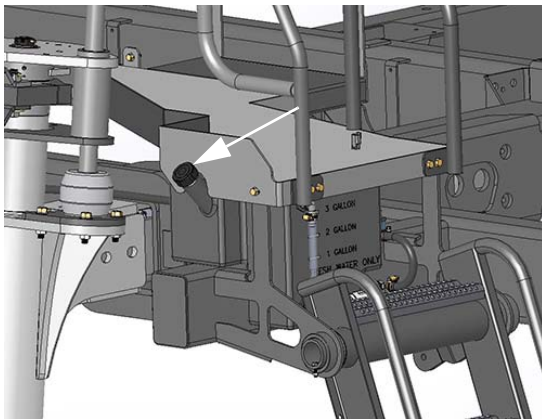

Hand Wash Fill Port
(Located beneath platform near ladder)
-Typical View

4. Press the Hand Wash Pump Power Switch (located on top of pump) in the ON position.

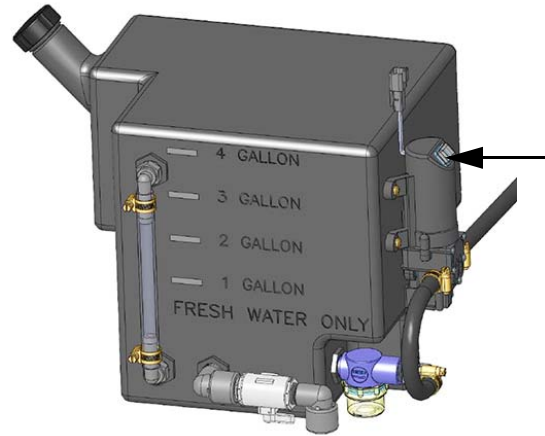

Hand Wash Pump Power Switch
(Located on top of pump)
-Typical View

5. Open the Hand Wash Valve (located near bottom of hand wash reservoir) until no antifreeze comes out of lower hand wash outlet. Close valve when finished.

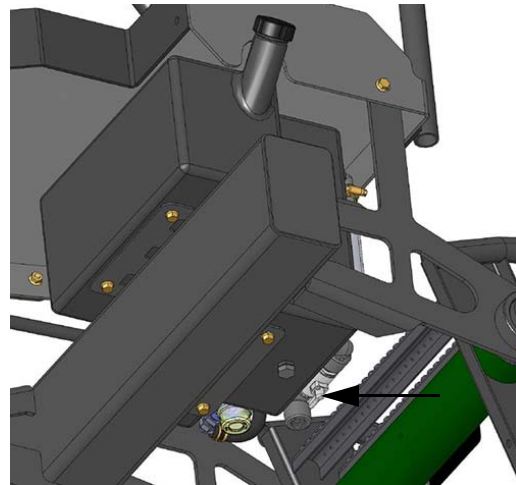

Hand Wash Valve
(Located near bottom
of hand wash reservoir)
-Typical View

6. Press and hold the Hand Wash Foot Pedal (located along the left-hand lower handrail) until no antifreeze comes out of the upper hand wash outlet. Release foot pedal when finished.



Hand Wash Foot Pedal
(Located along the left-hand lower handrail)
-Typical View

6. If the Hand Wash System was winterized prior to storage, fill hand wash reservoir with fresh water and drain before use.
7. Thoroughly clean the machine and its attachments.
8. Perform all recommended services as instructed elsewhere in this section.
9. Attach the spray boom and manually cycle all of the hydraulic functions 2 or 3 times to thoroughly lubricate the components. Test the NORAC® system and all of its functions according to the manufacturer's operation manual.
10. Reset date and time on Machine Display.
11. For starting instructions, refer to "Engine - Starting" provided in the *Engine and Drive Systems Section* elsewhere in this manual.

7. Turn the Hand Wash Pump Power Switch OFF.

Removing From Storage

NOTICE

Protective compounds such as grease can harden under exposure to weather conditions. Be sure to remove any dried grease and reapply new, if necessary.

1. Inspect the condition of and test the air pressure of all tires.
2. Carefully unseal all openings that were previously sealed in the "Preparing for Storage" process.
3. Clean and reinstall the batteries. Be sure to attach the battery cables to the proper terminals.
4. Tighten all belts. Inspect and replace any worn belts.
5. Check the engine oil, hydraulic oil, and engine coolant levels, and add if necessary.

NOTE: A mixture of 50/50 water/antifreeze will cool adequately in the summer, as well as protect in winter.

TRANSPORTING

When driving on a public roadway or elsewhere, be aware of any situation where the sprayer will be passing under an object with a clearance lower than the transporting height of the machine.

CAUTION

Hagie Manufacturing Company does not recommend any form of transportation other than driving the sprayer. Loading the sprayer onto a trailer may result in machine rollover.

WARNING

- Never operate the sprayer on a public roadway with solution in the tank.
- Never load or unload the sprayer with solution in the tank.
- Stopping the sprayer on trailer ramps may result in the sprayer to tip over.

CAUTION

Do not operate the machine at speeds exceeding 20 mph (32 km/h) with solution in the tank. Operating speeds exceeding 20 mph (32 km/h) with a fully loaded tank may result in tire blow-out or wheel hub damage and will void the warranty.

WARNING

When transporting the sprayer, observe the following to avoid serious injury or death:

- Check for adequate clearance before driving under any overhead obstructions.
- Contact with power lines may result in serious injury or death.



CAUTION

Do not transport the machine without the booms folded and in cradles. Failure to comply may result in injury or equipment damage.

Transportation Tank Level Switch

NOTE: STS16 Transport Limit = 600 gallons (2271L).

The solution tank on your machine is equipped with a Transportation Tank Level Switch (located inside the tank). This switch detects solution level, which if solution in the tank is above the transport limit, machine speed will be limited to 20 mph (32 km/h).

In addition, a warning message will appear on the Machine Display alerting you that solution tank level exceeds the transport limit and that machine speed will be limited. Press OK to acknowledge.



Limited Transportation Warning Message

Cradling the Booms



NOTE: Always cradle the booms before traveling, transporting, or parking for an extended period of time.

- Fold the outer boom extensions IN.

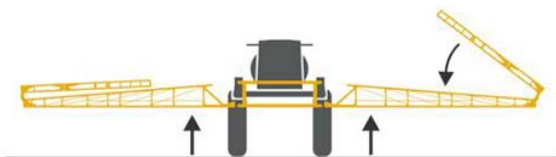

- Raise the transom all the way UP.
- Fold main boom sections IN toward the machine.

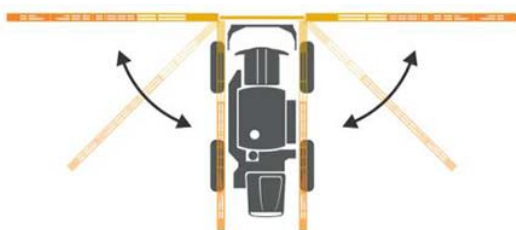

NOTE: When boom reaches the last 8-10 degrees of travel, it will automatically slow down to avoid impact with the cradle.

- Raise each individual boom until it clears the outer cradle stop.
- Fold the boom IN toward cradle back-stop.
- When boom touches the back-stop, lower until the full weight of the boom rests in the cradle.

Driving the Sprayer on a Public Roadway

1. Always have the booms in the folded and cradled position when driving or transporting the machine.
2. Transport machine at narrowest tread adjust setting only.
3. Use the flashing hazard/warning lights, day or night to warn other drivers, unless prohibited by law.
4. Know and obey all state laws for driving agricultural equipment on a public roadway.
5. Adjust machine speed to suit the conditions.
6. Slow down and use turn signals before turning.
7. Pull over to the side of the road before stopping.
8. Keep a proper lookout and maintain control of the machine.
9. Do not drive under trees, bridges, wires, or other obstructions unless there is adequate clearance.
10. Use extra care before entering or exiting a public roadway.
11. Ensure the SMV (Slow Moving Vehicle) and SIS (Speed Indicator Symbol) emblems are properly displayed to warn other drivers, unless prohibited by law.
12. Do not drive the machine at speeds exceeding 20 mph (32 km/h) with solution in the tank. Operating speeds exceeding 20 mph (32 km/h) with a fully loaded tank may result in tire blow-out or wheel hub damage and will void the warranty.

Loading

| |
|---|
|  WARNING |
| <p>Keep all persons away from trailer when loading or unloading the sprayer. Failure to comply may result in serious injury or death.</p> |

| |
|--|
| NOTICE |
| <p>Read and understand the trailer manufacturer's operation manual. Hitch the trailer to the pulling vehicle according to their recommendations.</p> |

| |
|---|
| NOTICE |
| <p>The loaded height and width of the trailer must conform to state law in which it is being used. Do not exceed the trailer manufacturer's recommendations on loaded weight.</p> |

1. Pull the trailer to flat ground.
2. Apply the pulling vehicle's parking brake and turn the engine OFF.
3. Use tire chocks to keep the trailer from moving.
4. Fold the booms and lower into cradles.
5. Lower the trailer ramps and set the ramp spacing for the machine's tread width setting.
6. Have an attendant help guide you onto the trailer.
7. Allow enough room between the sprayer and the pulling vehicle for turning.
8. Secure the sprayer onto the trailer using the recommended securement restraints (see trailer manufacturer's operation manual).
9. Cover or remove the SMV (Slow Moving Vehicle) and SIS (Speed Indicator Sym-

bol) emblems when traveling over 35 mph (55 km/h).

Unloading

1. Pull the trailer to flat ground.
2. Apply the pulling vehicle's parking brake and turn the engine OFF.
3. Use tire chocks to keep the trailer from moving.
4. Lower the trailer ramps and set the ramp spacing for the machine's tread width setting.
5. Carefully release the securement restraints.
6. Have an attendant help guide you off of the trailer.
7. Uncover or replace the SMV and SIS emblems.

Towing

| |
|---|
| NOTICE |
| <p>Sprayer should never be towed under any circumstances. Machine damage will occur and will void the power train warranty.</p> |



Contact your local John Deere dealer if towing is unavoidable.

LIFTING YOUR MACHINE

WARNING

Do not lift machine by more than one or two lifting points at the same time. Failure to comply will cause the machine to become unstable, resulting in serious injury or death.

WARNING

Use extreme caution when supporting machine by a lifting point. Failure to obtain proper location and lifting equipment may cause the machine to become unstable, resulting in serious injury or death.

NOTICE

Lift machine on hard level surface with properly rated equipment only.



RISK OF INJURY DUE TO IMPROPER LIFTING.
DO NOT ATTEMPT TO LIFT MACHINE
WITHOUT JACKS PROPERLY SEATED IN THE
LIFTING POINT CONTAINMENT RINGS.

There are four (4) designated lifting points on the machine. These points are located on the frame near each leg and are equipped with containment rings for safe jack location.

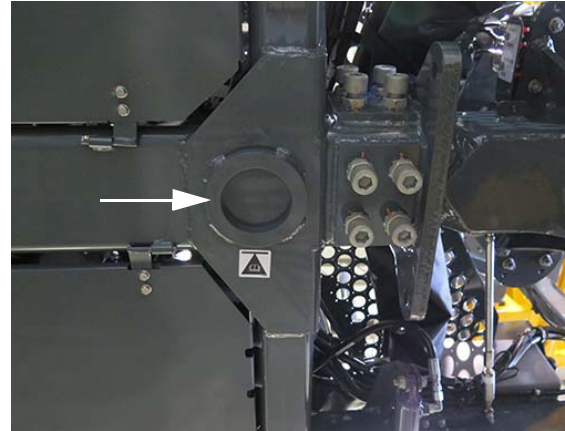

Lifting Point Containment Ring
(Located on the frame near each leg)
-Typical View

To Lift Machine (Bottle Jacks)

1. Shut the engine off.

NOTE: The parking brake will engage automatically when the engine is shut off.

2. Place wood blocks in front and rear of the tires not being lifted.
3. Align jack with Lifting Point Containment Ring.



Align Jack with Lifting
Point Containment Ring
-Typical View

4. Connect air supply to jack.
5. Tap air supply handle and slowly insert jack into Lifting Point Containment Ring.

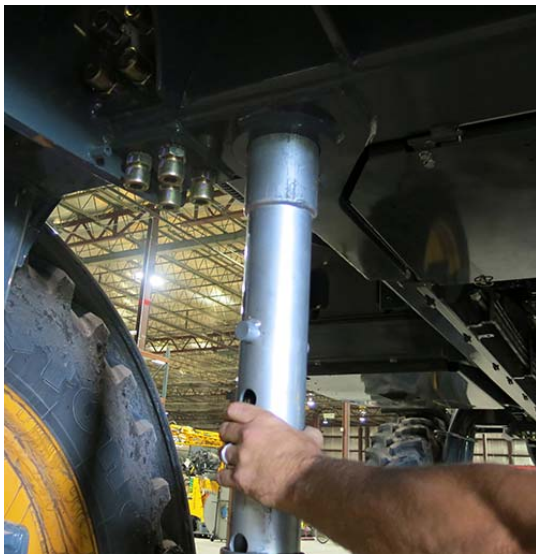

Insert Jack into Lifting
Point Containment Ring
-Typical View

6. Once jack is fully seated into the Lifting Point Containment Ring, continue to press and hold air supply handle until the machine reaches desired height.

! WARNING

Ensure lock pins are fully inserted at base of jack. Do not rely on jack air supply to support a raised machine. Sudden loss of air pressure will cause the machine to become unstable, resulting in serious injury or death.

7. Install Lock Pins to the base of jack.



Lock Pin Installation
-Typical View

8. Reverse steps to lower machine.

QUICK-TACH SYSTEM - SPRAY BOOMS

⚠ CAUTION

When operating or positioning the booms, observe the following safety precautions. Failure to comply may result in injury or equipment damage.

- Do not unfold boom extension when main boom is in cradle.
- Do not operate machine with one boom wing out of cradle and the other boom wing in cradle.
- Ensure booms are folded and in cradle before transporting the machine.

⚠ WARNING

When connecting or disconnecting the booms, observe the following safety precautions:

- Monitor both sides of the boom during fold procedure.
- Select a safe area that is solid and level before unfolding/folding the booms.
- Clear area of personnel.
- Check for overhead obstructions.
- Do not unfold or fold booms near power lines. Contact with power lines can result in serious injury or death.



⚠ WARNING

Turn the engine OFF before connecting/disconnecting any hoses or electrical lines. Failure to comply may result in serious injury or death.

Connecting the Boom

1. Square up to the boom.

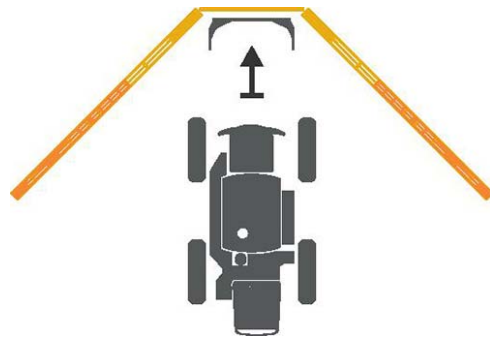

2. Disengage the Quick-Tach Lock Assemblies by pulling the Lock Pins (located on the front left and right-hand side of machine) OUT as far as it will go until it is in the “lock-out” position.

NOTE: “Lock-out” position prevents re-locking while attaching or detaching the attachment.



Lock Pin
(Located on the front left and
right-hand side of machine)
-Typical View
** Disengaged position shown*

3. Slowly pull into the attachment.
4. Ensure the Attachment Hooks are high enough to clear the Mounting Pins.



Attachment Clearing Mounting Pin
-Typical View

5. If necessary, lower the machine by rotating the corresponding Air Suspension Valves (located on the left-hand front air bag) in the COUNTER-CLOCKWISE (Deflate) position.

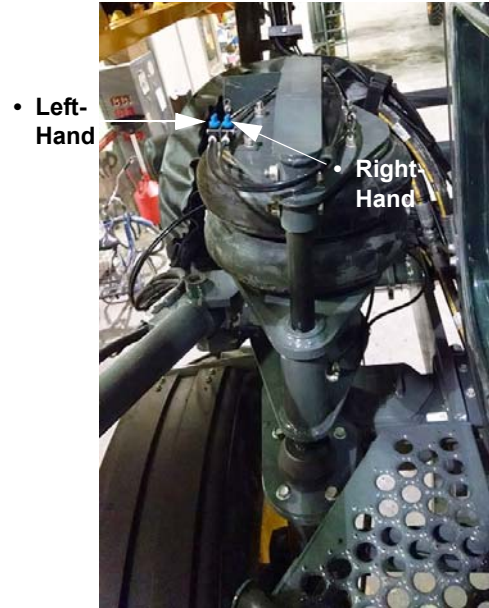

Air Suspension Valves
(Located on the left-hand front air bag)
-Typical View

6. Engage the parking brake.
7. **Turn the engine OFF before connecting any hoses or electrical lines!**
8. Connect all Solution, Foam Marker (if equipped), NORAC® (if equipped), Hydraulic, and Electrical Connections.

Solution Connection



Solution Connection - **Standard**
(Located on the front
right-hand side of machine)
-Typical View

Dual Product System Solution Connections

-If Equipped

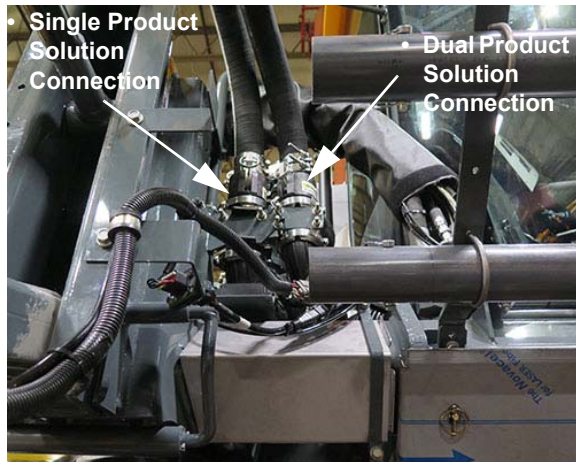

Solution Connections - **Single/Dual Product**
(Located on the front right-hand side of machine)
-Typical View

NORAC Connection

-If Equipped



NORAC Connection
(Located on the front right-hand side of machine)
-Typical View

Foam Marker Connection

-If Equipped



Foam Marker Connection
(Located on the front right-hand side of machine)
-Typical View

Quick Connect Multi-Coupler

- Install the Hydraulic/Electrical Connections (located on the left-hand side of attachment) into the Multi-Coupler Receptacle (located on front left-hand side of machine), ensuring full engagement.
- Push the Quick Connect Handle (located on the Hydraulic/Electric Multi-Coupler Assembly) OUT to engage hydraulic/electrical connections.



Hydraulic/Electric Multi-Coupler Assembly
(Located on the front
left-hand side of machine)



NORAC Hand Valve (2) - *if equipped*
(Located on the left and
right-hand level cylinders)
-Typical View
* *Right-hand level cylinder shown*

Dual Product System Electrical Connection

-If Equipped

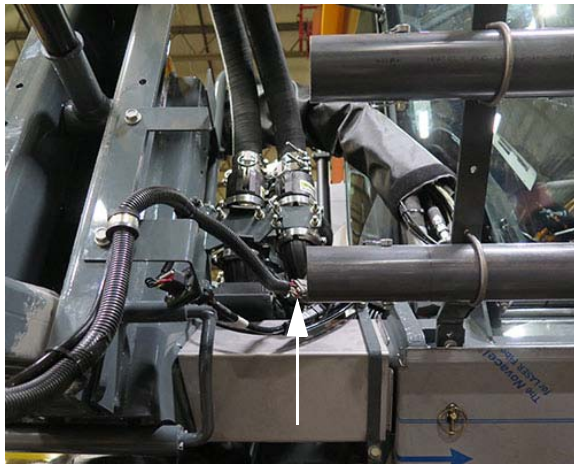

Dual Product Electrical Connection
(Located on the front
right-hand side of machine)
-Typical View

9. Rotate the NORAC Hand Valve - *if equipped* (located on the left and right-hand level cylinders) in the OPEN (counter-clockwise) position.

10. Start the engine.
11. If the air bags were previously deflated, raise the machine by rotating the corresponding Air Suspension Valves in the CLOCKWISE (Inflate) position.
12. Press and hold the Transom Switch (located on the Hydrostatic Drive Control Handle) in the UP position to raise the boom until the Attachment Hooks fully engage.

NOTE: *Press and hold the Transom Switch only until the Attachment Hooks become fully engaged.*



Transom Switch - UP
(Located on the Hydrostatic
Drive Control Handle)
-Typical View

NOTE: Raising the attachment will allow the weight of the boom to pull the Attachment Hooks over the Mounting Pins. You will notice a change of weight as the machine begins to support the attachment.

13. Engage the Quick-Tach Lock Assemblies by pushing the Lock Pins IN, ensuring full engagement.

NOTE: If necessary, adjust the level cylinders to free the Lock Pins.

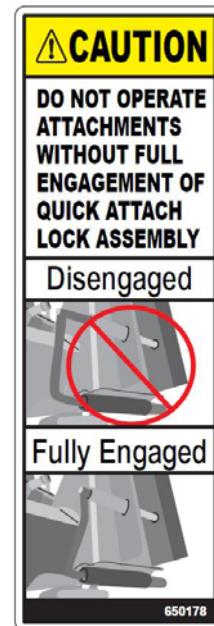

Lock Pin
-Typical View
** Engaged position shown*

14. Place boom stands in the TRAVEL position by removing the lock pin and mounting bolt and sliding the leg all the way UP (on each side).

NOTE: Reinstall the mounting bolts and lock pins to secure leg in the travel position (on each side).

See “Boom Stands” elsewhere in this section for further information.

NOTICE

Do not operate the boom while the boom stands are in the lowered position. Failure to comply may result in property damage.



Boom Stand in “Travel” Position
-Typical View

Disconnecting the Boom

Before disconnecting the boom, determine a proper storage location. When choosing a place to store the boom, there are three important things to keep in mind:

Is the ground level?

The ground must be level to help prevent the attachment from falling over. Level ground will also minimize stress on the frame of the attachment when in storage.

Is there enough space?

The attachment needs to be partially open for it to stand properly, but be aware of the room that is needed for the attachment and adequate space to travel around it safely.

Is it accessible?

The attachment needs to be positioned so you can connect easily. Ensure there is enough room and that the attachment is not blocked, or blocking other items.

If temporarily storing the attachment on a soft surface (such as grass), it is recommended to place blocks or wood beneath the stands’ feet to prevent the attachment from sinking into the ground.

NOTE: It is NOT recommended to store the attachment on a soft surface for an extended period of time, due to the risk of settling soil, even when blocks or wood are used.

Unfolding the Boom for Storage

The booms must be partially open for stability when unattached from the machine. Unfold the booms approximately 45° while maintaining sufficient clearance for repositioning during reattachment. This position will allow the booms to sit level with the transom without causing excessive stress on either part. It will also keep the weight from shifting too much in either direction (rearward or forward), which could cause the boom to tip over and/or difficulty in connecting or disconnecting the attachment.

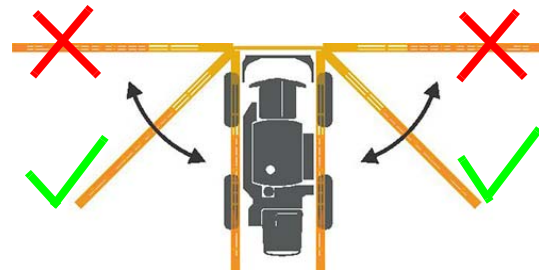

-Typical View

1. Press and hold the corresponding Left and Right Boom Switches (located on the Hydrostatic Drive Control Handle) in the UP position to remove boom wings from cradles.



Left and Right-Hand Boom Switches
(Located on the Hydrostatic
Drive Control Handle)
-Typical View

2. Press and hold the corresponding Left and Right Boom Switches in the OUT position to unfold the boom wings until **partially** open.

NOTE: Booms only need to be unfolded far enough to clear the boom cradles and lower (e.g. enough to clear the front tires and allow room for steering to line up the boom). Do NOT fully extend.

3. Lower the boom and secure the boom stands (if equipped) in the DOWN position.
See “Boom Stands” elsewhere in this section for further information.

WARNING

Lower boom to the ground before disengaging the Quick-Tach Lock Assemblies.

4. Press and hold the corresponding Left and Right Boom Switches in the DOWN position to point boom tips down (until tips touch the ground).
5. Disengage the Quick-Tach Lock Assemblies by pulling the Lock Pins (located on

the front left and right-hand side of machine) OUT as far as it will go until it is in the “lock-out” position.

NOTE: “Lock-out” position prevents re-locking while attaching or detaching the attachment.

NOTE: If necessary, adjust the level cylinders to free the Lock Pins.



Lock Pin
(Located on the front left and
right-hand side of machine)
-Typical View
** Disengaged position shown*

6. If necessary, lower the machine by rotating the corresponding Air Suspension Valves (located on the left-hand front air bag) in the COUNTER-CLOCKWISE (Deflate) position.

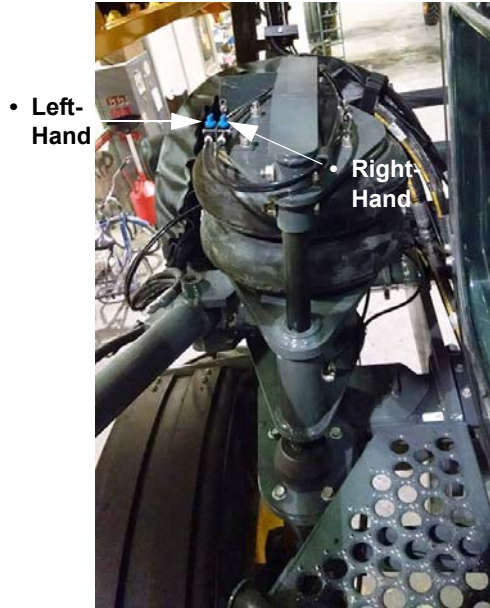

Air Suspension Valves
(Located on the left-hand front air bag)
-Typical View

7. Ensure the Boom Solution Valve Switches (located on the side console) are in the OFF position.



Boom Solution Valve Switches
(Located on the side console)
-Typical View

8. Disconnect the Solution, Foam Marker (if equipped), and NORAC® (if equipped) Connections, ensuring not to leave the ends in an area where they may become damaged or contaminated.

Solution Connection



Solution Connection - **Standard**
(Located on the front
right-hand side of machine)
-Typical View

Dual Product System Solution Connections

-If Equipped

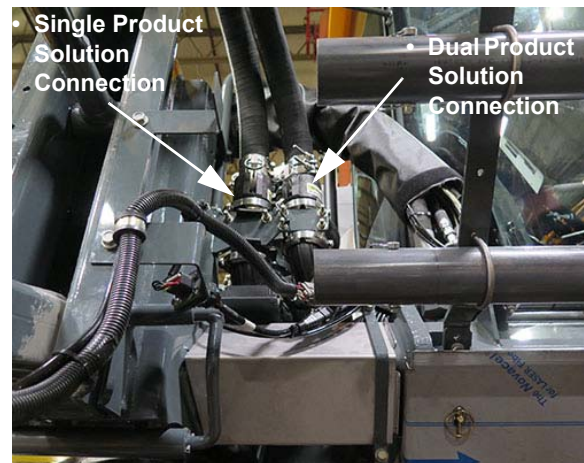

Solution Connections - **Single/Dual Product**
(Located on the front
right-hand side of machine)
-Typical View

Foam Marker Connection

-If Equipped



Foam Marker Connection
(Located on the front
right-hand side of machine)
-Typical View

NORAC Connection

-If Equipped



NORAC Connection
(Located on the front
right-hand side of machine)
-Typical View

bly until Attachment Hooks clear the
Mounting Pins.



Transom Switch - DOWN
(Located on the Hydrostatic
Drive Control Handle)
-Typical View

NOTE: If the air bags are inflated, a “bounce back” effect may be felt when the weight of the boom has been relieved from the machine. Once the air bags have cycled, the machine will adjust to the new weight.



Attachment Clearing Mounting Pin
-Typical View

9. Press and hold the Transom Switch (located on the Hydrostatic Drive Control Handle) in the DOWN position and slowly lower the boom/transom assem-

10. Engage the parking brake.

11. Turn the engine OFF before disconnecting any hoses or electrical lines!

12. Push the Quick Connect Handle (located on the Hydraulic/Electric Multi-Coupler Assembly) IN to disengage hydraulic/ electrical connections.



Hydraulic/Electric Multi-Coupler Assembly
(Located on the front
left-hand side of machine)

13. Remove Hydraulic/Electrical Connections from the Multi-Coupler Receptacle.
14. **If equipped**, disconnect the Dual Product Electrical Connection (located on the front right-hand side of machine).

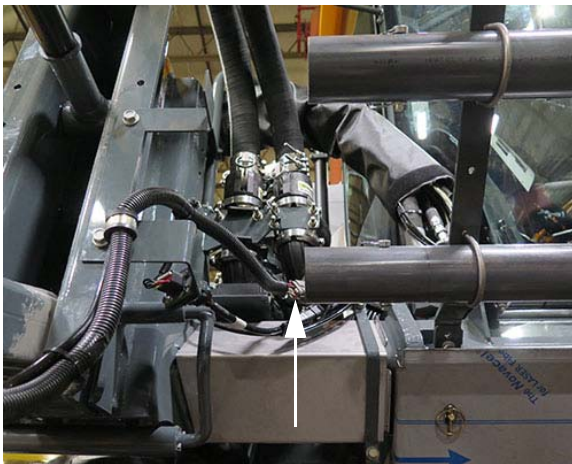

Dual Product Electrical Connection
- *if equipped*
(Located on the front
right-hand side of machine)
-Typical View

15. **If equipped**, rotate the NORAC Hand Valve (located on the left and right-hand level cylinders) in the CLOSED (clock-wise) position.



NORAC Hand Valve (2) - *if equipped*
(Located on the left and
right-hand level cylinders)
-Typical View
* *Right-hand level cylinder shown*

16. If no other attachment is going to be installed, re-lock the Quick-Tach Lock Assemblies by pushing the Lock Pins IN.
17. Start the machine.
18. Disengage the parking brake and slowly back away from the boom.
19. If the air bags were previously deflated, raise the machine by rotating the corresponding Air Suspension Valves in the CLOCKWISE (Inflate) position.

Boom Stands

90/100' Spray Booms

Your boom is featured with three boom stands - two (2) located on the transom and one (1) located on each of the inner boom sections.

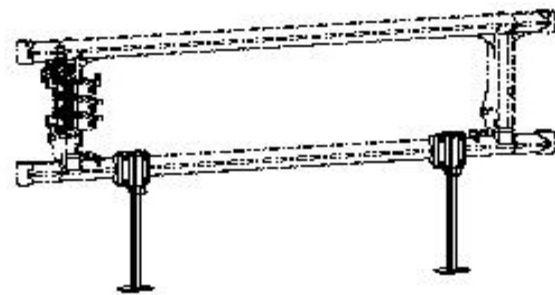

Booms Stands
(90' Boom)
-Typical View

Each boom stand has a leg with a “foot” on the bottom and a hex bolt in the top hole of the leg to secure it from sliding off, as well as a “snap” lock pin in the hole (located directly below the bracket) to maintain it’s position.

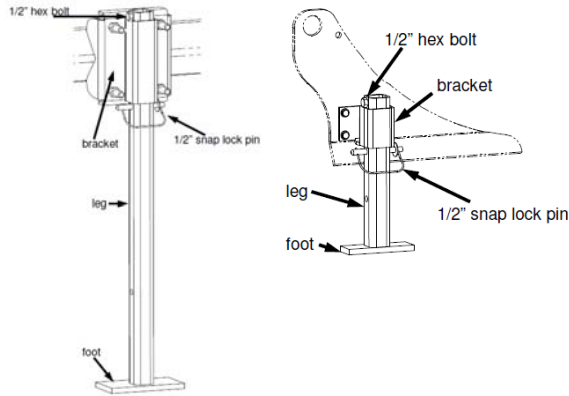

Boom Stand Assembly
-Typical View



Lock Pin
(Located on the outer side of transom frame)
-Typical View

120/132' Spray Booms

Your boom is featured with two (2) boom stands (located on the transom).

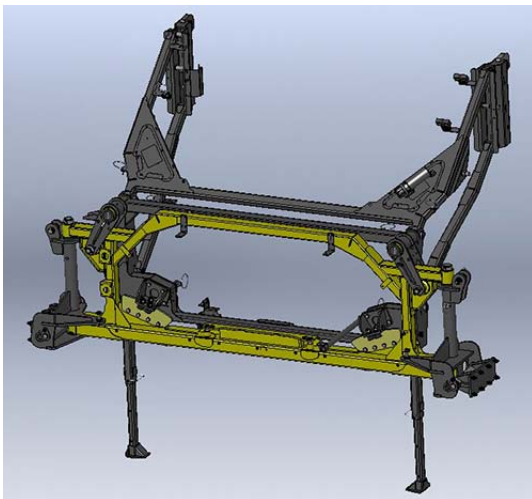

Booms Stands
(120/132' Boom)
-Typical View



Lock Pin Removed
-Typical View

2. While supporting the bottom “foot” end of boom stand, remove the Mounting Bolt (located on the outer side of transom frame) and slowly lower boom stand to desired position.

To Extend Booms Stands:

1. Remove Lock Pin (located on the outer side of transom frame) and set aside.



Mounting Bolt
(Located on the outer
side of transom frame)
-Typical View

3. With the boom stand at desired position, reinstall the Mounting Bolt, ensuring the holes of the boom stand and transom frame are properly aligned.

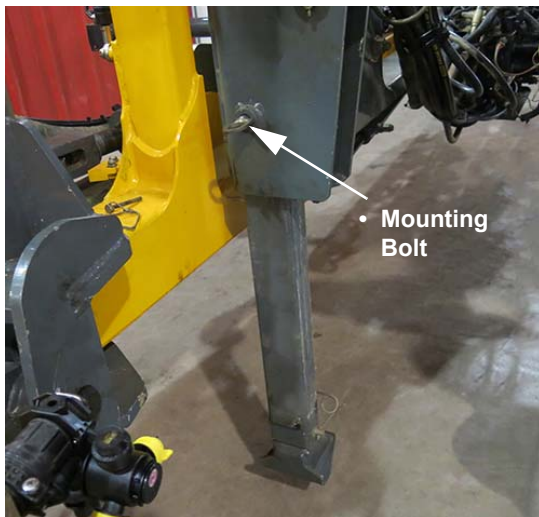

Boom Stand
(Extended position shown)
-Typical View

4. Reinstall Lock Pin (that was previously removed in Step 1).
5. Repeat Steps 1-4 on opposite side of boom.

NOTE: For additional adjustment, the “foot” end of the boom stand may also be adjusted to best suit your situation

*(e.g. boom height, ground level, etc.)
Adjust in the same manner as
previously described.*

6. Reverse steps to store booms stands in “travel” position.

AIR SUSPENSION EXHAUST

(Air Bags)

The Air Suspension Exhaust System is used to manually inflate/deflate the air bags on your machine, providing you with a smooth, consistent ride quality. It also provides ease when connecting and disconnecting attachments.

NOTE: Inspect air bags daily for leaks and/or cracking.

To Inflate/Deflate the Air Bags

- Rotate the corresponding Air Suspension Valves (located on the left-hand front and rear air bags) in the COUNTER-CLOCKWISE position to deflate.
- Rotate the corresponding Air Suspension Valves in the CLOCKWISE position to inflate.

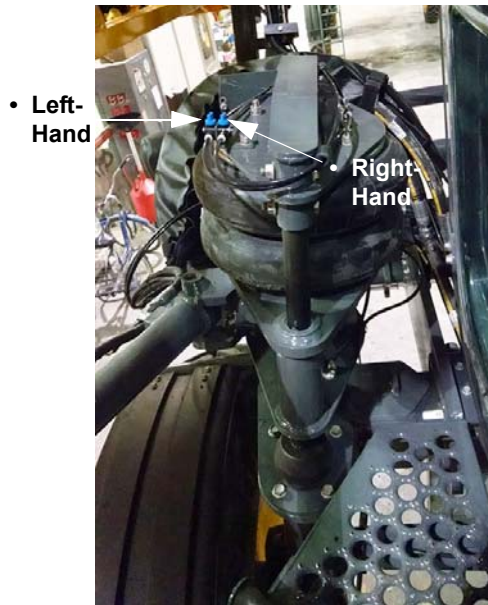

Air Suspension Valves
(Located on the left-hand front and rear air bags)
-Typical View
** Front left-hand air bag shown*

NOTICE

Keep the hand wash reservoir full of fresh water at all times for immediate use should contact with hazardous chemicals occur.

NOTICE

Fill the hand wash reservoir with fresh water only.

NOTICE

The Hand Wash System has been tested using RV-type antifreeze. Fill hand wash reservoir with fresh water and drain before initial use.

HAND WASH SYSTEM

⚠ WARNING

Do not drink from this container. Container may become contaminated by sprayer chemicals. Fill with clean water only.

N408864

⚠ CAUTION

The Hand Wash System is not a substitute for Personal Protective Equipment (PPE). Always use the proper PPE (i.e. safety eye wear, face shields, protective clothing, etc.) when handling chemicals.

Your machine is featured with two Hand Wash Stations - one located near the bottom of the hand wash reservoir and the other mounted on the left-hand handrail near the cab door for your convenience in rinsing dirt and chemicals from hands before entering the cab.

The system uses a diaphragm-type water pump that can deliver up to 1 GPM (3.8 l/min) and is equipped with an in-line strainer to filter impurities and increase pump life. The water pump is also equipped with an internal pressure switch for on-demand use when the hand wash valves are opened. A power switch is located on the water pump to manually shut the pump down in the event of system failure (i.e. leaks, faulty pressure switch, etc.)

NOTE: The Hand Wash System is powered by battery power and will operate even when the machine is off.

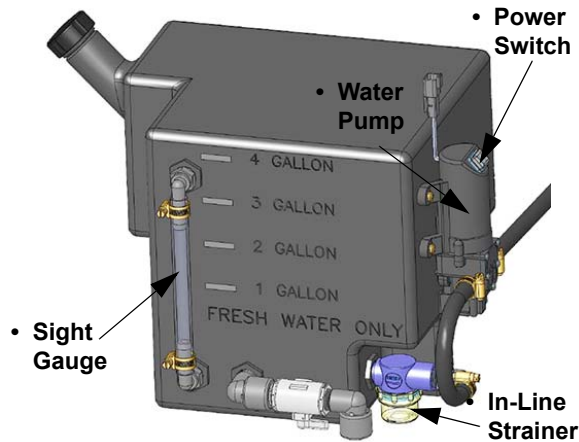

Hand Wash Reservoir
(Located beneath rear left-hand platform)
-Typical View

NOTE: Remove Hand Wash Strainer (located near the bottom of hand wash reservoir) and clean strainer screen periodically to avoid dirt and debris from entering the system.

Filling the Hand Wash Reservoir

NOTE: Hand Wash Reservoir Capacity = 4 gallons (15 L)

- Remove fill cap from the Hand Wash Fill Port (located near the ladder) and set aside.

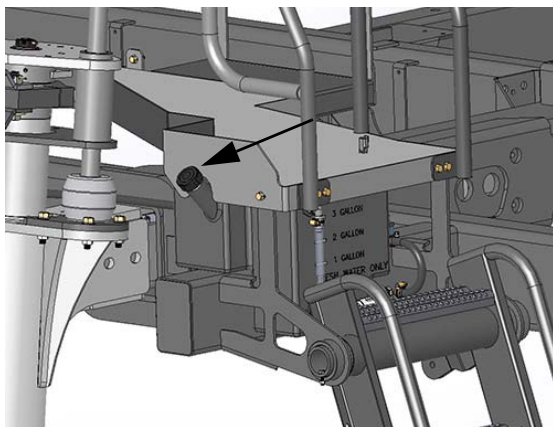

Hand Wash Fill Port
(Located near ladder)
-Typical View

- Pour fresh water down the fill port opening.

NOTE: A sight gauge is located on the side of the hand wash reservoir to visually check water level.

- Reinstall fill cap.

Dispensing Fresh Water

To Dispense Fresh Water From Upper Water Outlet

- Press and hold the Hand Wash Foot Pedal (located along the lower handrail on left-hand side of machine).

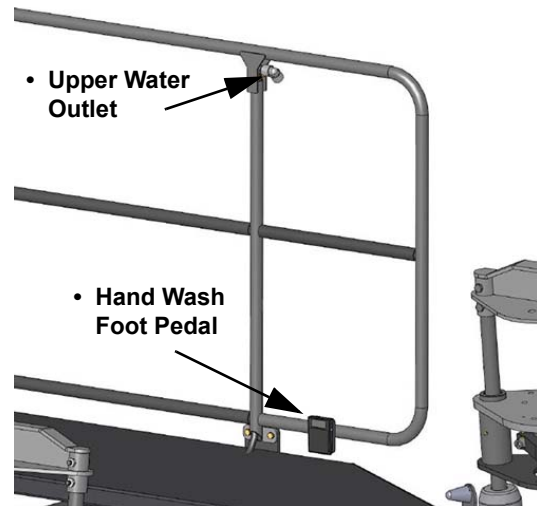

Upper Water Outlet/Hand Wash Foot Pedal
(Mounted on left-hand handrail near cab door)
-Typical View

- Release foot pedal when finished.

To Dispense Fresh Water From Lower Water Outlet

- Rotate the Hand Wash Valve (located near the bottom of hand wash reservoir) in the “clockwise” position to OPEN.

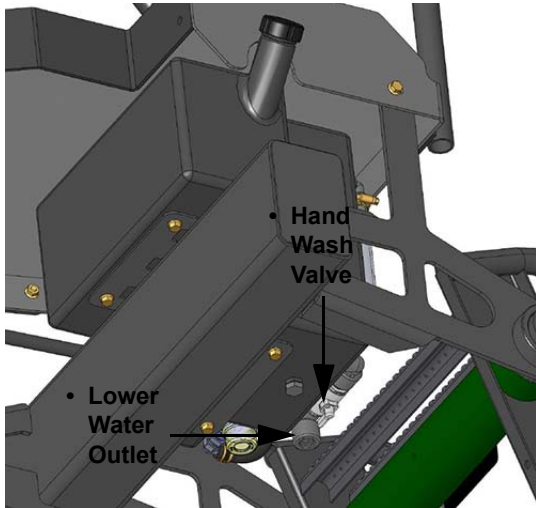

Lower Water Outlet/Hand Wash Valve
(Located near the bottom
of hand wash reservoir)
-Typical View

- Rotate the Hand Wash Valve in the “counter-clockwise” position to CLOSE.



Hood Latch (2)
(Located on each side of top hood)
-Typical View

- Press and hold the Hood Actuator Switch (located near front top of hood) in the OPEN (Left) position.
- Release Hood Actuator Switch when hood has opened to desired position.

HOOD OPERATION

NOTICE

Do not operate machine with the hood open. Failure to comply may result in property damage.

The rear hood is equipped with an electric hood actuator, which allows the hood to be opened and closed by the touch of a switch.

To Open Hood

- Unlock the two Hood Latches (located on each side of top hood).



Hood Actuator Switch
(Located near front top of hood)
-Typical View

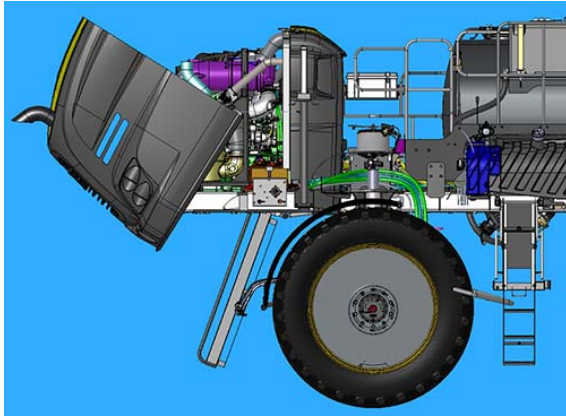

Rear Hood
(Open position shown)
-Typical View

To Close Hood

- Press and hold the Hood Actuator Switch in the CLOSE (Right) position until hood is fully retracted and comes to a complete stop.

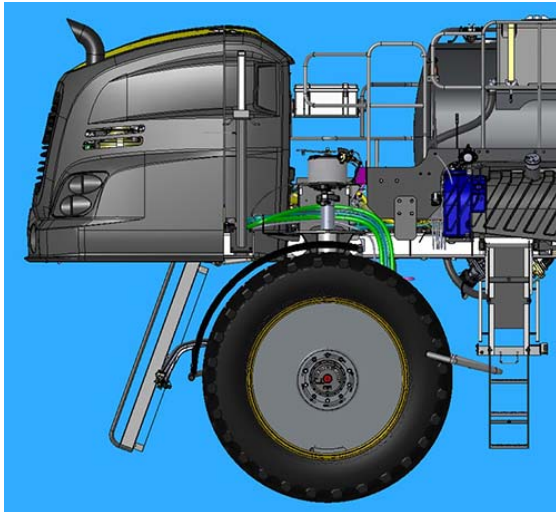

Rear Hood
(Closed position shown)
-Typical View

- Lock the two Hood Latches.

Powering the Hood Actuator (when battery charge is depleted)

Refer to “Engine - Starting” provided in the *Engine and Drive Systems Section* elsewhere in this manual for information on jump starting the machine.

LADDER - FUEL FILL



PINCH/CRUSH HAZARD
Keep hands and fingers
away from pinch/pivot areas

NOTICE

Ensure the ladder is in the upright (stored) position before operating the machine. Failure to comply may result in property damage.

Your machine is featured with a Fuel Fill Ladder for ease in accessing the fill ports on the fuel and diesel exhaust fluid (DEF) tanks.

To Lower Ladder

1. Remove the two (2) Lock Pins (located on each side of the ladder assembly).

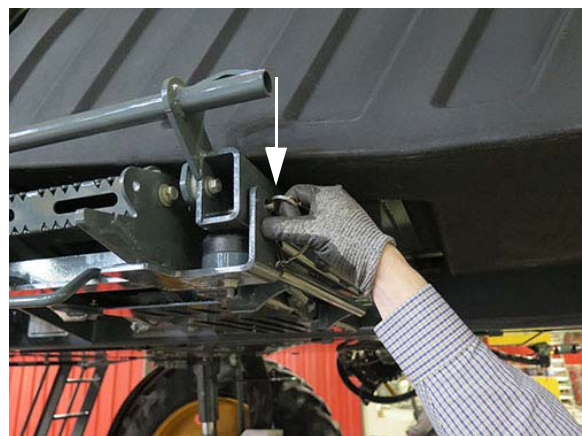

Lock Pins (2)
(Located on each side
of the ladder assembly)
-Typical View

2. Firmly grasp the Lower Ladder Handle and pull ladder assembly **DOWNWARD**, partially lowering the ladder.



Lower Ladder Handle
-Typical View



Ladder **Disengaged** from Track Detent
(Left-hand side of ladder shown)
-Typical View

3. While maintaining hold of the Lower Ladder Handle, firmly grasp the Top Ladder Handle with opposite hand and pull ladder assembly **OUTWARD**, as shown in the following photo.



-Typical View



Ladder **Engaged** in Track Detent
(Left-hand side of ladder shown)
-Typical View

5. Pull back Security Pin (located on the lower right-hand side of folded ladder assembly) and rotate pin either forward or backward to lock pin into position.
4. Using both hands, pull ladder towards you, ensuring the upper ladder is seated flush in the track detents on both sides.



Security Pin
(Located on lower right-hand
side of folded ladder assembly)
-Typical View

6. Proceed to unfold lower section of Ladder, ensuring the ladder platform deploys properly.

NOTE: The ladder platform may deploy with gravity. If not, assist by manually moving into deployed position.



Ladder Platform
-Typical View

7. Finish unfolding the lower section of ladder.



Fuel Fill Ladder
(Lowered position shown)
-Typical View

8. Engage Security Pin into LOCKED position.

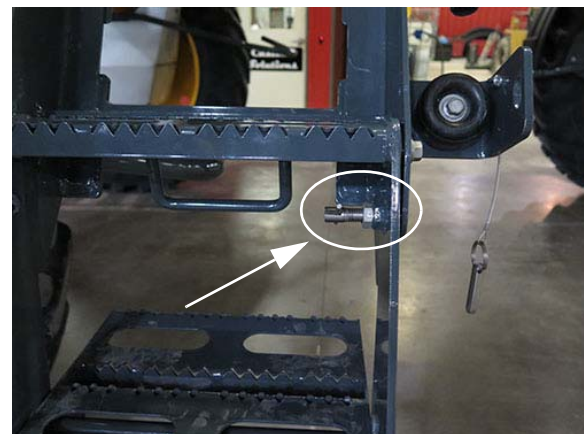

Security Pin
-Typical View

NOTE: Ensure the upper section of Ladder is seated flush in the track detents (on both sides).

9. Ladder is now ready for use.

To Raise Ladder

Reverse steps to raise the ladder to stored position.

Maintenance

Refer to “Service - Lubrication” provided in the *Maintenance Section* elsewhere in this manual for further information.

TALL CROP PACKAGE - INSTALLATION

- If Equipped

NOTE: Ensure correct Belly Shield configuration before installing.

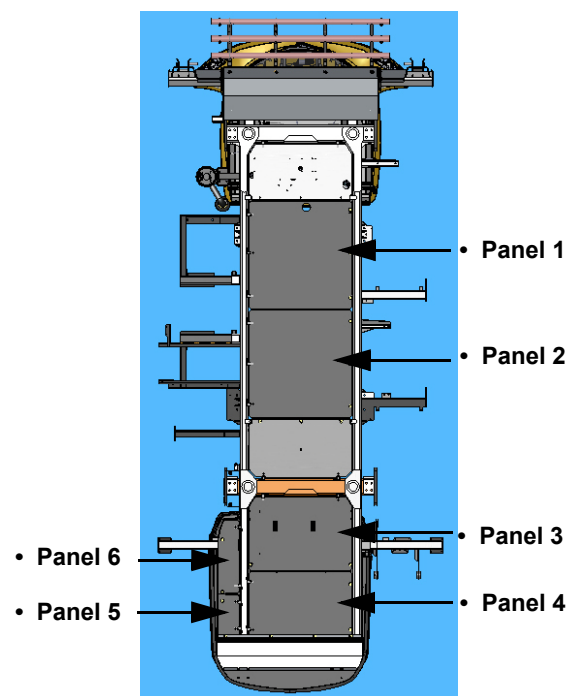

Belly Shield Installation
-Typical View

* View shown from bottom side of machine

NOTE: Two persons are required when installing the Tall Crop Package.

Installing Belly Shields (1-3)

1. Install Securement Pin Assembly (Hanger Pin and Securement Pin) onto each Retaining Bracket (located along frame).

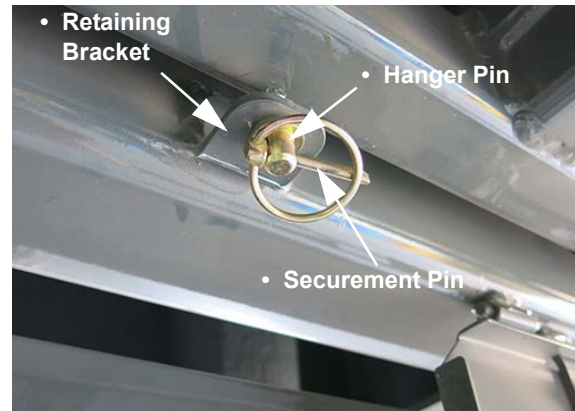

Retaining Bracket/
Securement Pin Assembly
-Typical View

2. Starting with Panel 1, install Support Hook Assemblies into the corresponding Hinge Bushings (located along frame).
3. Install Cotter Pin onto the end of each support hook.

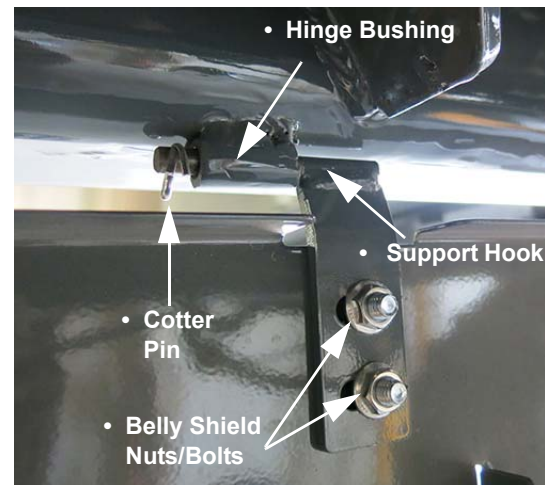

-Typical View

NOTE: Ensure belly shield nuts and bolts are loose.

4. On opposite side of machine, remove previously installed Securement Pins (from Hanger Pins).
5. Lift panel and align hole openings with Hanger Pins. Attach by reinserting the Securement Pins.

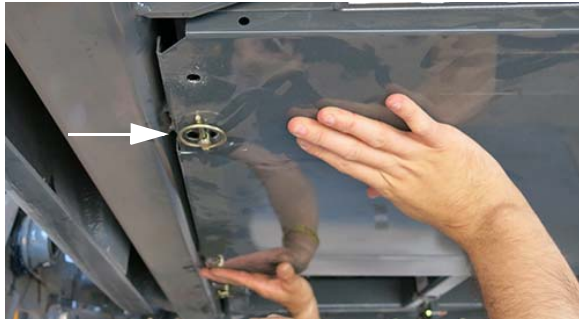

Securement Pin
(Installed into Hanger Pin)
-Typical View

- Using a 1/2" wrench or socket, tighten the belly shield nuts and bolts, as shown.



-Typical View

- Repeat previous steps to install Panels 2 and 3.

Installing Belly Shields (4-6) and Brush Curtain

- Install Securement Pin Assembly (Hanger Pin and Securement Pin) onto each Retaining Bracket (located along frame).

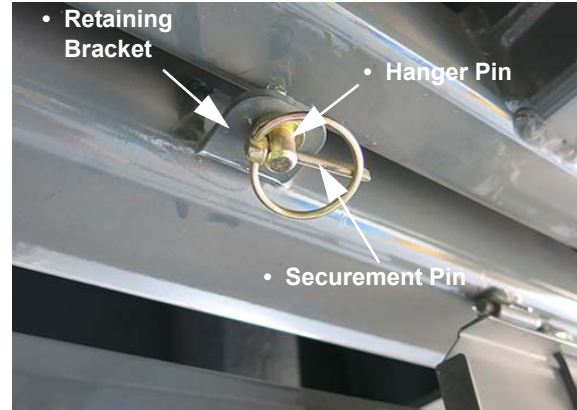

Retaining Bracket/
Securement Pin Assembly
-Typical View

- Starting with Panel 4, install Support Hook Assemblies into the corresponding Hinge Bushings (located along frame).
- Install Cotter Pin onto the end of each support hook.

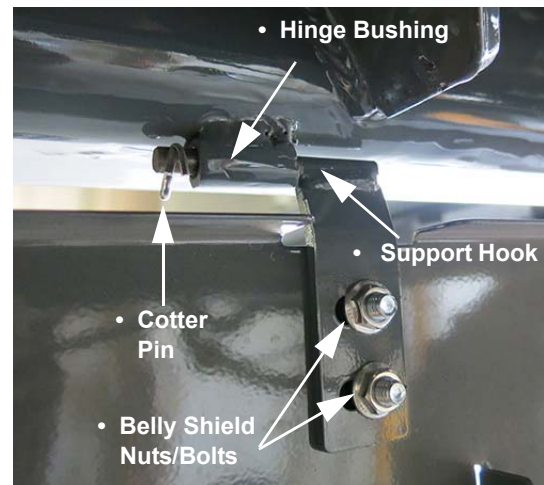

-Typical View

NOTE: Ensure belly shield nuts and bolts are loose.

- Repeat Steps 2-3 to install Panels 5 and 6, ensuring belly shield nuts and bolts are loose.
- Install Hanger Pins along side of Panels 4, 5, and 6.



Hanger Pins
(Install pins onto Panels 4, 5, and 6)
-Typical View

NOTE: Ensure each Hanger Pin opening is facing UP (toward length of panel), as shown in the following photo.



Hanger Pin Installation
-Typical View

6. On opposite side of machine, remove previously installed Securement Pins (from Hanger Pins).
7. Lift Panel 4 and align hole openings with Hanger Pins. Attach by reinserting the Securement Pins.

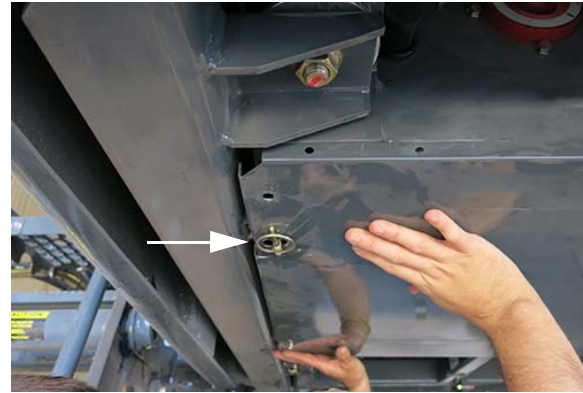

Securement Pin
(Installed into Hanger Pin)
-Typical View

8. Using a 1/2" wrench or socket, tighten the belly shield nuts and bolts, as shown.



-Typical View

9. Lift and secure Panels 5 and 6, tightening belly shield nuts and bolts in the same manner.

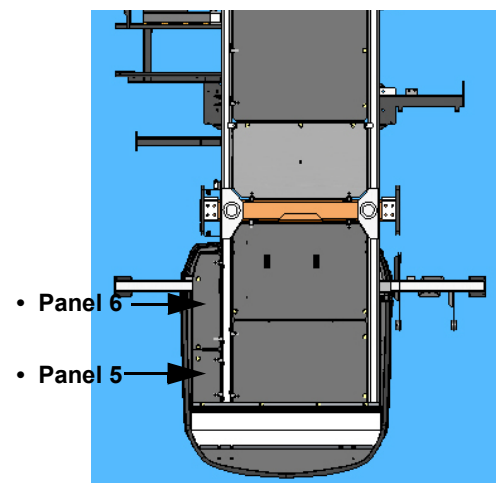

Rear Belly Shield Installation
-Typical View

To Assemble/Install Brush Curtain:

10. Place Curtain Mounting Bracket (bend side up) beneath edge of Brush Curtain, aligning the pre-drilled holes on each.
11. Arrange Curtain Support Strips along the edge of Brush Curtain, aligning the pre-drilled holes.

NOTE: Ensure the notches of each Curtain Support Strip are facing inward (where they will later be adjoined together).

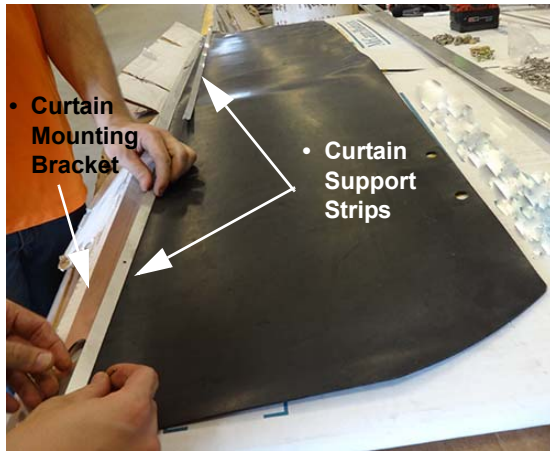

-Typical View

12. Starting at the end of the assembly, insert a 1/8" stainless steel rivet through the top of Curtain Support Strip, Brush Curtain, and Curtain Mounting Bracket.

NOTE: Ensure Curtain Mounting Bracket bend is facing UP, as shown in the following photo.



Brush Curtain Assembly
-Typical View

13. Use a rivet gun to secure.



-Typical View

14. Repeat process to secure the remainder of the assembly, ensuring that the notches of Curtain Support Strips adjoin together.
15. Install the assembled Brush Curtain onto the previously installed Hanger Pins (located on Panels 4 and 5).



Brush Curtain Installation
-Typical View

16. Install Securement Pins into each of the Hanger Pins.

NOTE: Install the two center pins first, followed by the two outer pins.



Securement Pin
(Installed into Hanger Pin)
-Typical View

17. Remove hairpin and Bent Pull Hitch Pin from each hood bracket (located on the left and right-hand side of hood) and set aside.

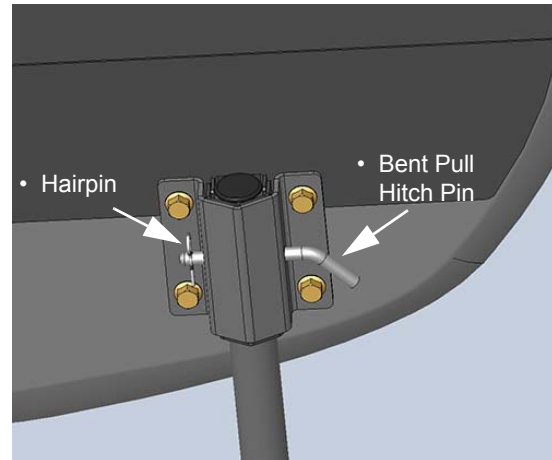

Hairpin/Bent Pull Hitch Pin Assembly
(Located on each left and right-hand hood bracket)
-Typical View

** Your machine may vary in appearance, depending on available equipment.*

18. Remove the four (4) front mounting bolts (two located on each left and right-hand hood bracket).

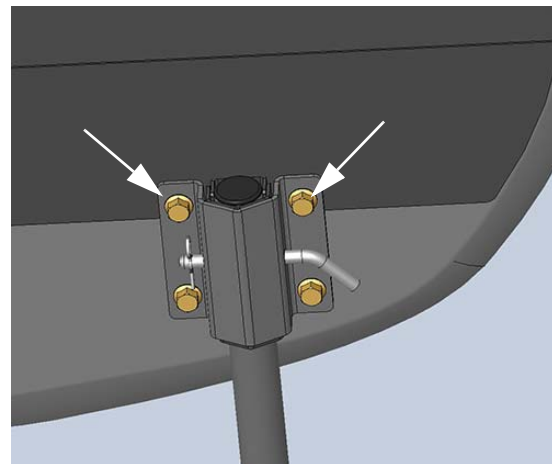

Mounting Bolts
(Two located on each left and right-hand hood bracket)
-Typical View

** Your machine may vary in appearance, depending on available equipment.*

19. Insert bolts (that were just removed) through the corresponding Brush Curtain holes (located at bottom of curtain) and reinstall bolts to hood bracket, as shown in the following illustration.

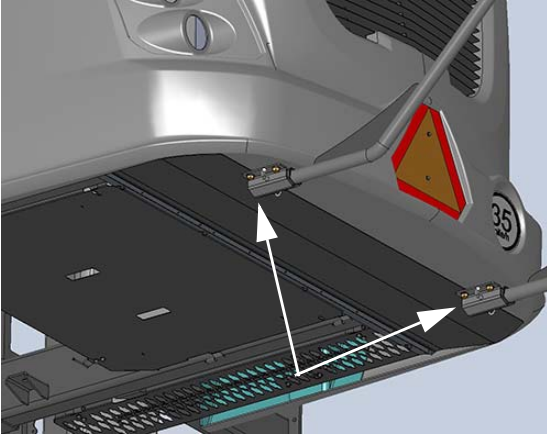

Brush Curtain Attached to Hood
-Typical View

20. Reinstall hairpin and Bent Pull Hitch Pin onto each hood bracket.
21. Belly Shield and Brush Curtain installation complete.

Installing Front Brush Guard

1. Install Brush Guard Mounting Bracket between right-hand cross member and hose assembly, as shown.



Brush Guard Mounting Bracket
(Right-hand side of machine shown)
-Typical View

2. Install additional Brush Guard Mounting Bracket on left-hand cross member, as shown.



Brush Guard Mounting Bracket
(Left-hand side of machine shown)
-Typical View

3. Assemble Mounting Bracket Hardware (bracket, hanger pin, and bolt) together.

NOTE: Ensure the hanger pin hole opening is facing toward the length of the bracket.

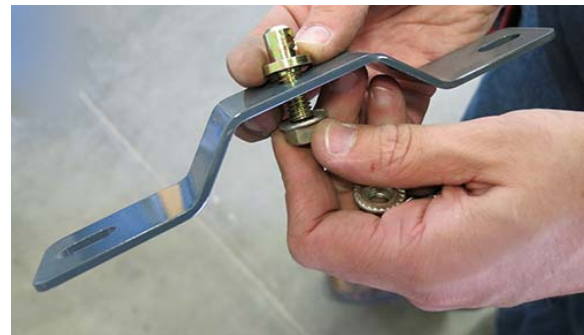

Mounting Bracket Hardware
-Typical View

4. Attach Brush Guard Rail to left-hand cross member by installing 4" Anchor Bolts through the top and bottom of the Mounting Bracket Hardware, and securing to the previously installed Brush Guard Mounting Bracket.

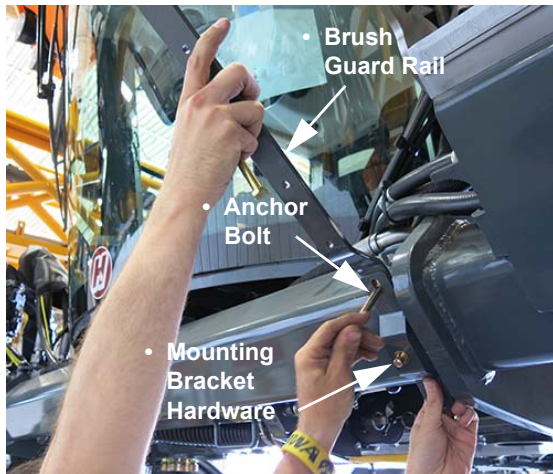

Brush Guard Rail Assembly
-Typical View



Anchor Bolt Assembly
-Typical View

5. Repeat Step 8 to install Brush Guard Rail to right-hand cross member.
- NOTE: The outer left and right-hand Brush Guard Rails must be installed prior to the center rails.*
6. Install each center Brush Guard Rail by attaching with Rail Support and two (2) 7 1/2" Anchor Bolts, as shown.

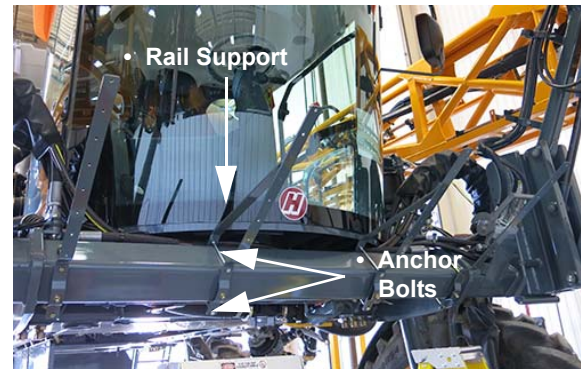

Center Brush Guard Rail Assembly
-Typical View

7. Fasten each center Brush Guard Rail and Rail Support together using a 5/16" x 1" bolt, as shown in the following photo. Tighten bolt with a 9/16" wrench.

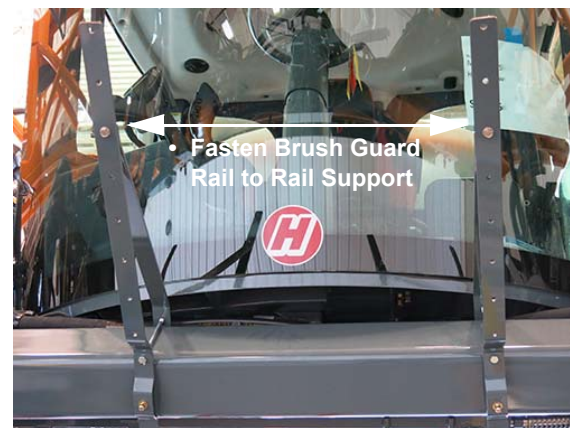

-Typical View

8. Using a tape measure, ensure the distance from the outer edge of the right and left-hand cross member support tube to the inner edge of the hanger pin (of the outer Brush Guard Rail) is 2 1/2" (6.4 cm), as shown in the following photo.

NOTE: If needed, use a rubber mallet to obtain proper distance.



-Typical View

9. Once proper distance is achieved, hand-tighten top and bottom Anchor Bolts on each side.



-Typical View

10. Using a tape measure, ensure the distance from the outer edge of the right and left-hand cross member support tube to the inner edge of the hanger pin (of the center Brush Guard Rail) is 24" (61 cm), as shown in the following photo.

NOTE: If needed, use a rubber mallet to obtain proper distance.



-Typical View

11. Repeat Step 15 on opposite side, ensuring 24" (61 cm) distance.
12. Once proper distance is achieved, hand-tighten top and bottom Anchor Bolts of each center Brush Guard Rail.



-Typical View

13. Starting at the bottom, install Brush Guard Tubes to Brush Guard Rails, securing with U-Bolts and tightening with a 1/2" wrench.

NOTE: Ensure U-Bolts are not over-tightened. If the bolts are snugged too tight, the brush guard extensions will not extend properly.

NOTE: Ensure the Brush Guard Adjustment Clips located on each end of tube are facing upward when installing.

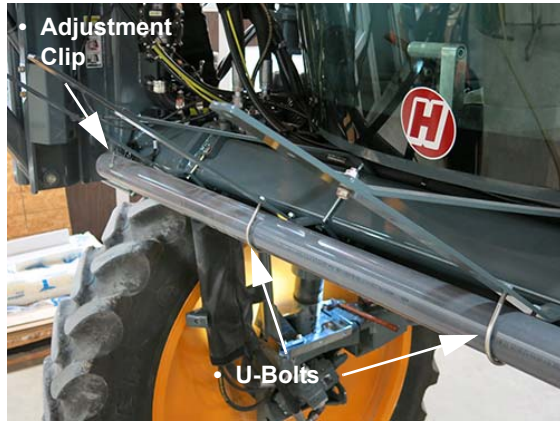

Brush Guard Tube
-Typical View



Brush Guard Adjustment Clip
(Located on the end of each tube)
-Typical View

14. Repeat process for remaining brush guards.



Brush Guard Installation
-Typical View

Brush Guard Extension

- Remove adjustment clip from pin (located on the end of each brush guard tube).
- Extend tube to desired position, ensuring hole openings align.
- Reinstall adjustment clip to pin.

Installing Front Shield

1. Pre-assemble support hook and bolts to the Front Shield (one side only) and hand-tighten with a 1/2" wrench.
2. Install support hook into the corresponding hinge bushing (located beneath the front end of machine near tread adjust bolts).

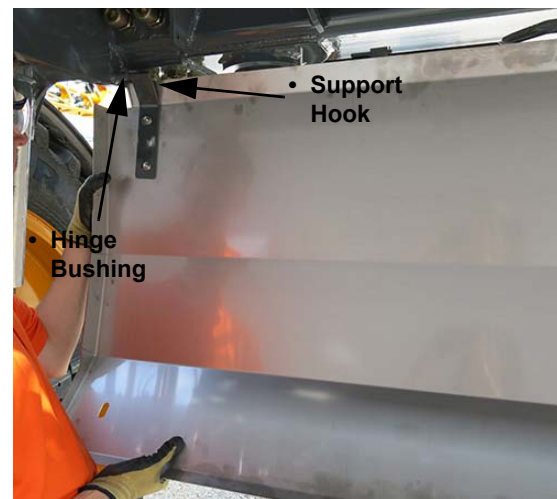

-Typical View

3. Install support hook into hinge bushing on opposite side of machine (without bolts and nuts).
4. Lift Front Shield and install bolts through back side of panel and support hook. Hand-tighten with a 1/2" wrench.



-Typical View

5. Lift Front Shield and install the four (4) Securement Pins into the previously installed hanger pins (located on front of machine).

NOTE: Brush Guard Rails may require adjustment to ensure proper alignment of the Front Shield.



Front Shield Installation
-Typical View

Installing Crop Dividers

1. Install two (2) black caps (located on each end of the four Crop Dividers).
2. Remove the three (3) Leg Mounting Bolts and set aside.
3. Slide Crop Divider Mounting Plate beneath leg plate, as shown in the following photo.

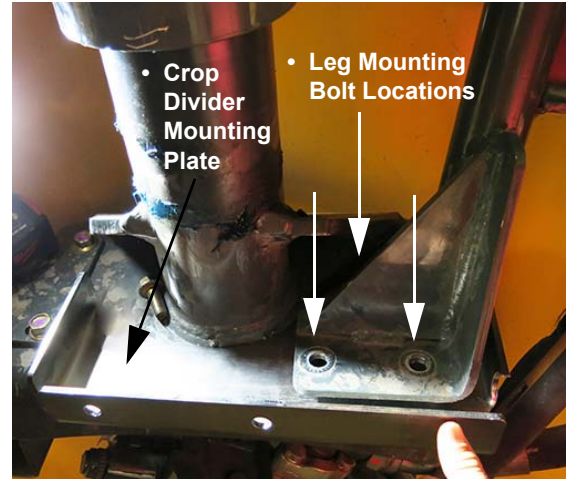

-Typical View

4. Align Leg Mounting Bolt and Crop Divider Mounting Plate holes and re-install previously removed bolts, tightening with a 3/4" wrench or socket.
5. Install additional Mounting Plate Bolt, as shown in the following photo. Tighten with a 3/4" wrench or socket.



Mounting Plate Bolt
-Typical View

6. Slide Crop Divider into mounting plate, as shown.

NOTE: Ensure the hook end of the Crop Divider is facing outward.



Installed Crop Divider
-Typical View

7. Install two (2) Crop Divider Mounting Bolts through Crop Divider mounting plate and tube. Tighten with a 3/4" wrench or socket.

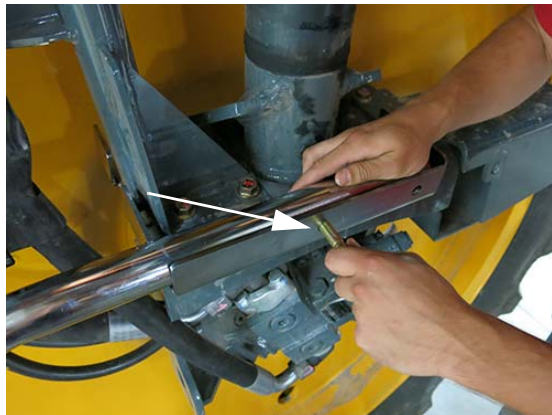

Crop Divider Mounting Bolt
-Typical View

8. Repeat steps to install remaining Crop Dividers.

Installing Wheel Covers

NOTICE

Remove two (2) lug nuts at a time from the wheel bolts when installing the hub cap adapter plates.

1. Remove two (2) lug nuts from two (2) of the wheel bolts and set aside.

2. Install Hub Cap Adapter Plate onto the two bolts, as shown in the following photo.
3. Reinstall the two lug nuts onto bolts and tighten with a 33 mm socket/air wrench. Refer to "Service - Bolt Torque" provided in the *Maintenance and Storage Section* elsewhere in this manual for further information.

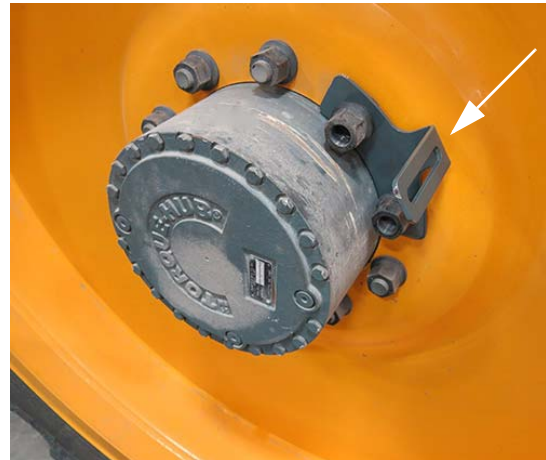

Hub Cap Adapter Plate
-Typical View

4. Perform Steps 1-3 to install remaining adapter plates, ensuring only two (2) lug nuts are removed from the wheel bolts at one time.



-Typical View

5. Install the Hub Cap Adapter Weldment onto the outside of the previously installed Hub Cap Adapter Plates.

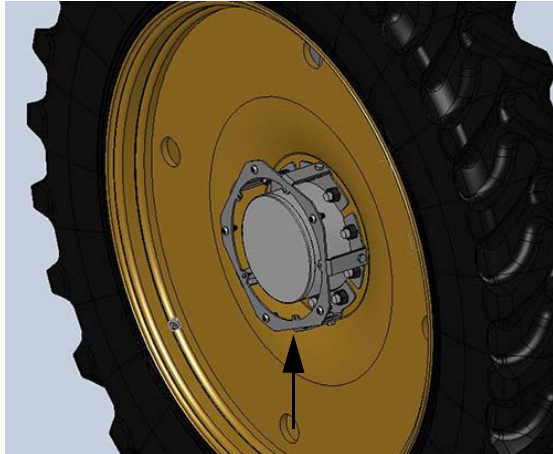

Hub Cap Adapter Weldment
-Typical View

6. Install 1/2" bolt through the hub cap adapter assembly. Install nut to bolt, but do not tighten.

NOTE: Repeat for each adapter assembly location around the wheel hub.



Hub Cap Adapter Bolt Installation
-Typical View

7. Install Wheel Cover onto the hub cap adapter assembly.



-Typical View

8. Install 1/2" mounting bolt through the front of wheel cover and Hub Cap Adapter Weldment mounting holes.



Wheel Cover Mounting Bolt Installation
-Typical View

9. Install nut to mounting bolt and tighten with a 5/16" hex wrench.

NOTE: Repeat for each adapter assembly location around the wheel hub.

10. Install remaining 1/4" bolt (tighten with 3/8" wrench) and nut (tighten with 7/16" wrench).
11. With hub cap bolted to adapter weldment, slide hub cap until the outer edge touches the rim, creating a smooth transition from wheel to hub cap.
12. Using a 3/4" wrench, tighten hub cap adapter bolts (that were previously installed in Step 6).

13. Install Hub Cap Ring to center of wheel cover, ensuring the hole openings of each are properly aligned.
14. Install 1/4" bolt through ring and wheel cover, tightening with a 3/8" wrench. Wheel cover installation complete.



Hub Cap Ring
-Typical View



Wheel Cover Installation
-Typical View

TROUBLESHOOTING

| Problem | Possible Cause | Suggested Remedy |
|--|---|---|
| Engine will not crank | <ul style="list-style-type: none"> • Dead battery • Poor battery connections • Starter or starter relay • Blown fuse in engine electric box • Battery Disconnect Switch in the OFF position • Parking brake not engaged | <ul style="list-style-type: none"> • Recharge or replace battery • Clean and tighten connections • Test (rebuild or replace) • Check/replace fuse • Turn Battery Disconnect Switch to the ON position • Engage parking brake |
| Engine will not start | <ul style="list-style-type: none"> • Fuel tank empty • Clogged fuel filter(s) • Cold weather • E-Stop Switch is engaged • Low starter speed • Blown fuse in engine box | <ul style="list-style-type: none"> • Fill fuel tank • Replace fuel filter(s) • Refer to the engine manufacturer's operation manual for cold weather starting • Disengage E-Stop Switch • Check starter and battery • Check/replace fuse |
| Engine overheats | <ul style="list-style-type: none"> • Engine overload • Dirty radiator core/grille screen • Faulty radiator cap • Fan malfunction • Faulty thermostat • Low coolant level | <ul style="list-style-type: none"> • Reduce load • Remove foreign material and clean all items • Replace radiator cap • Check fan speed • Replace thermostat • Refill to proper level with recommended coolant |
| Engine misfires (runs uneven/low power) | <ul style="list-style-type: none"> • Water in fuel • Dirty air cleaner element • Poor grade of fuel • Fuel tank vent clogged • Clogged fuel filter(s) | <ul style="list-style-type: none"> • Drain, flush, replace filter, fill system • Replace air cleaner element • Drain system, change to a higher fuel grade • Open fuel tank vent (in cap) • Replace fuel filter(s) |
| Engine knocks | <ul style="list-style-type: none"> • Low oil level in crankcase • Cold engine | <ul style="list-style-type: none"> • Add oil to full mark • Allow proper warm-up period, refer to engine manufacturer's operation manual |
| Solution Pump will not prime | <ul style="list-style-type: none"> • Low water level in pump • Air leak in suction line • Solution tank valve closed • Clogged or kinked vent line | <ul style="list-style-type: none"> • Ensure solution tank is not empty (solution pump is self-priming) • Inspect and tighten all fittings in suction line • Open solution tank valve, allow air to leave the system • Inspect vent line for blockage or kinking |



| | | |
|---|---|---|
| Erratic reading on pressure gauge | <ul style="list-style-type: none"> • Orifice in back of gauge clogged • Faulty gauge • Air leak in suction line • Solution strainer plugged • Glycerin leaking from pressure gauge | <ul style="list-style-type: none"> • Remove gauge, clean orifice, reinstall • Replace gauge • Inspect and tighten all fittings in suction line • Check solution strainer • Replace gauge |
| Electric solution valve malfunction | <ul style="list-style-type: none"> • Faulty ground • Dirty contact terminals • Separation in wire • Faulty switch • Bad valve | <ul style="list-style-type: none"> • Clean and tighten ground • Clean contact terminals • Check continuity and replace wire • Replace switch • Replace valve |
| Solution pump not producing adequate pressure | <ul style="list-style-type: none"> • Clogged line strainer screen • Air leak in suction flow to pump • Restricted solution flow to pump • Suction hose collapsed • Hydraulic failure | <ul style="list-style-type: none"> • Remove screen, clean thoroughly, tighten strainer cap to avoid air leak • Inspect and tighten all fittings on suction line • Ensure Main Tank Valve is completely open • Obstruction at inlet end of hose causing high vacuum on hose • Contact your local John Deere dealer for assistance |
| | | |
| Machine will not move in either direction | <ul style="list-style-type: none"> • Engine speed too low • Oil level in hydraulic reservoir too low • Clogged pressure filter • Hydrostatic System failure | <ul style="list-style-type: none"> • Set engine at operating RPM • Fill hydraulic reservoir to proper level with approved oil • Replace pressure filter • Contact your local John Deere dealer for assistance |
| Machine will move in only one direction | <ul style="list-style-type: none"> • Hydrostatic System failure | <ul style="list-style-type: none"> • Contact your local John Deere dealer for assistance |
| Hydrostatic system responding slowly | <ul style="list-style-type: none"> • Engine speed too low • Oil in hydraulic reservoir low • Cold oil • Plugged filter • Partially restricted suction line • Hydrostatic System failure | <ul style="list-style-type: none"> • Set engine at operating RPM • Fill hydraulic reservoir to proper level with approved oil • Allow adequate warm-up period • Check and replace filter • Inspect for collapsed suction hose • Contact your local John Deere dealer for assistance |
| Noisy hydrostatic system | <ul style="list-style-type: none"> • Cold oil • Low engine speed • Oil level in hydraulic reservoir low • Hydrostatic System failure | <ul style="list-style-type: none"> • Allow adequate warm-up period • Increase engine speed • Fill hydraulic reservoir to proper level with approved oil • Contact your local John Deere dealer for assistance |



| | | |
|---|--|---|
| Entire hydraulic system fails to function | <ul style="list-style-type: none"> • Oil level in hydraulic reservoir too low • Auxiliary hydraulic system failure | <ul style="list-style-type: none"> • Fill hydraulic reservoir to proper level with approved oil • Contact your local John Deere dealer for assistance |
| Noisy hydraulic pump | <ul style="list-style-type: none"> • Oil level in hydraulic reservoir too low • Auxiliary hydraulic system failure | <ul style="list-style-type: none"> • Fill hydraulic reservoir to proper level with approved oil • Contact your local John Deere dealer for assistance |
| | | |
| AWS System will not turn on | <ul style="list-style-type: none"> • AWS Button (located on the Machine Display) is OFF • Machine not in Field Mode • Sensor or valve malfunction | <ul style="list-style-type: none"> • Turn AWS Button ON • Change machine's drive state to Field Mode • Contact your local John Deere dealer for assistance |
| AWS System is ON, but rear tires do not follow behind the front tires | <ul style="list-style-type: none"> • Machine speed is greater than AWS shutoff speed • Sensor or valve malfunction | <ul style="list-style-type: none"> • This is left up to the operator's discretion • Contact your local John Deere dealer for assistance |
| AWS System inoperable, machine will only move at slow speed | <ul style="list-style-type: none"> • Sensor malfunction | <ul style="list-style-type: none"> • Move the Hydrostatic Drive Control Handle to NEUTRAL, wait for the "FAULT" drive state to disappear on the Machine Display, and restart machine <p><i>NOTE: In Road mode, the rear tires are locked until the machine is put into Field mode.</i></p> |
| | | |
| Entire electrical system is dead | <ul style="list-style-type: none"> • Dead battery • Poor battery connection • Low charge rate • No charge rate • Battery Disconnect Switch is in the OFF position | <ul style="list-style-type: none"> • Replace battery • Clean and tighten battery connections • Tighten alternator belt • Replace alternator • Turn Battery Disconnect Switch to the ON position |
| Light system does not function | <ul style="list-style-type: none"> • Poor ground • Burned out bulb • Separation or short in wire • Blown fuse • Faulty switch • Ignition switch is OFF | <ul style="list-style-type: none"> • Clean and tighten ground • Replace bulb • Check continuity and replace wire • Replace fuse • Replace switch • Turn ignition switch ON |



INDEX

| | |
|--|-------|
| A Word From Hagie Manufacturing | |
| Company | 1-1 |
| About This Manual | 1-1 |
| Air Suspension Exhaust | 10-17 |
| All-Wheel Steer (AWS) | 4-15 |
| Application - Dual Product | 8-35 |
| Application | 7-64 |
| Batteries | 6-1 |
| Battery Disconnect Switch | 6-3 |
| Battery Tender | 6-4 |
| Draining Your Solution Tank - Dual | |
| Product | 8-34 |
| Draining Your Solution Tank | 7-47 |
| Emergency Exit | 2-7 |
| Emergency Stop | 2-7 |
| Engine - Starting | 4-1 |
| Engine Aftertreatment - Final Tier 4 | 4-3 |
| Fence Row Applicator | 7-40 |
| Filling Your Solution Tank - Dual | |
| Product | 8-30 |
| Filling Your Solution Tank | 7-41 |
| Fire Extinguisher | 2-8 |
| First Aid Kit | 2-8 |
| Foam Marker System | 7-52 |
| Fuse and Relay Ratings | 6-10 |
| Fuses and Relays | 6-5 |
| Hand Wash System | 10-18 |
| Hood Operation | 10-20 |
| Hydraulic System Components | 5-1 |
| Hydrostatic Drive | 4-10 |
| Identification | 1-2 |
| Intended Use | 2-1 |
| Ladder - Fuel Fill | 10-21 |
| Ladder | 5-10 |
| Lifting Your Machine | 10-4 |
| Machine Display | 3-28 |
| Modular Injection System | 7-55 |
| Operator's Station | 3-5 |
| Pressure Washer | 5-11 |
| Product Warranty | 1-2 |
| Quick-Tach System - Spray Booms | 10-6 |
| Reversible Fan | 5-5 |
| Rinse System - Dual Product | 8-17 |
| Rinse System | 7-48 |
| Roll-Over Protection Structure | |
| (ROPS) | 2-9 |
| Rotating Beacon | 2-6 |
| Safety Decals | 2-10 |
| Safety Messages Used In This | |
| Manual | 1-1 |
| Safety Precautions | 2-1 |
| Seat - Instructor | 3-4 |
| Seat - Operator | 3-1 |
| Seat - Operator (Premium) | 3-2 |
| Seat Belt | 2-6 |
| Service - Bolt Torque | 9-28 |
| Service - Engine Drive Belt | 9-27 |
| Service - Filters | 9-10 |
| Service - Fluids | 9-1 |
| Service - Lubrication | 9-22 |
| Service - Miscellaneous | 9-32 |
| Service - Toe-In | 9-30 |
| Service and Assistance | 1-2 |
| Service Intervals | 9-36 |
| Solution System - Operation | 7-37 |
| Solution System Components - Dual | |
| Product | 8-1 |
| Solution System Components | 7-28 |
| Solution System Operation - Dual | |
| Product | 8-12 |
| Specifications | 1-6 |
| Spray Boom - Rear | 7-26 |
| Spray Boom Hose Ring Installation | 7-1 |
| Spray Booms - 120/132' | 7-13 |
| Spray Booms - 90/100' | 7-2 |
| Storage | 9-40 |
| Tall Crop Package - Installation | 10-24 |
| Transporting | 10-1 |
| Tread Adjustment - Hydraulic | 5-6 |
| Troubleshooting | 10-37 |
| Video Camera Input Connections | 6-13 |

